

# FD2 Series FlexDraper® Header with FM200 Float Module

Operator's Manual

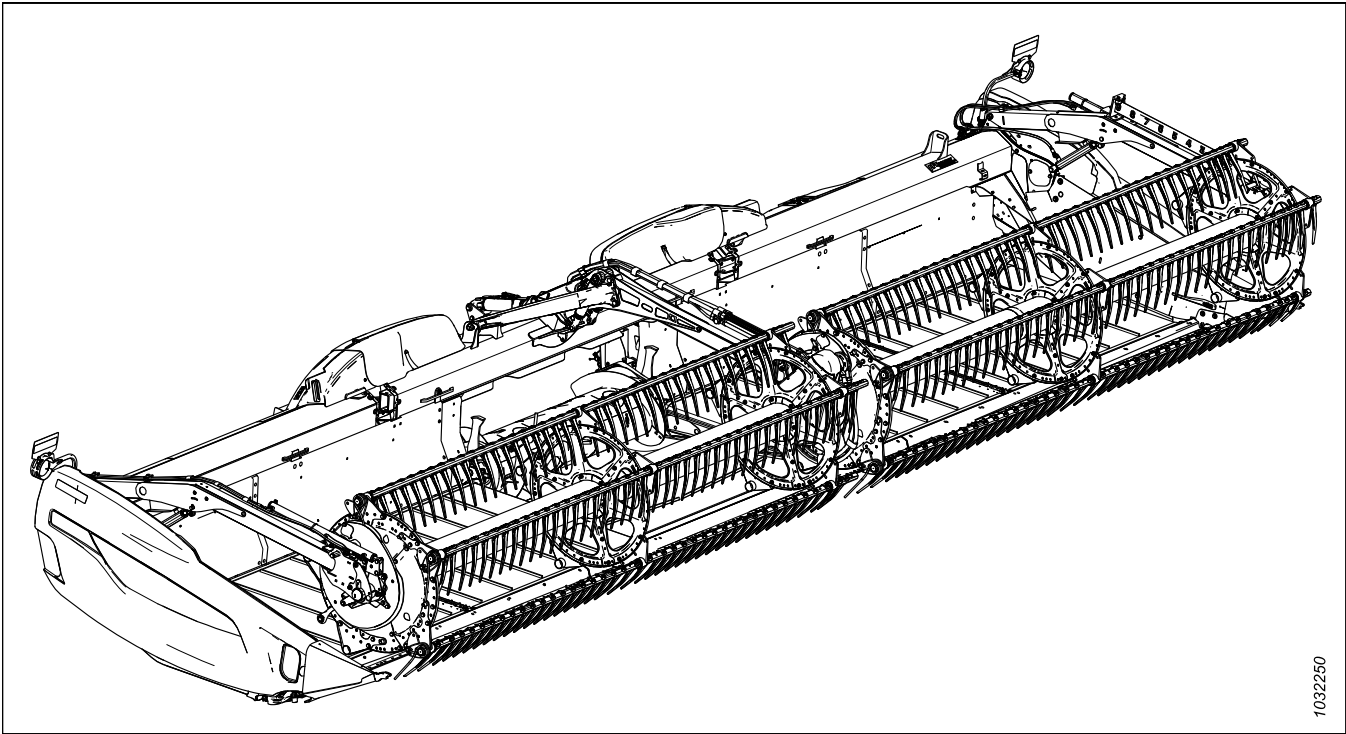
262608 Revision A

Original Instruction

*Featuring MacDon FLEX-FLOAT Technology®*

*The Harvesting Specialists.*

FD2 Series FlexDraper® Header



Published March 2024

© 2024 MacDon Industries, Ltd.

The information in this publication is based on the information available and in effect at the time of printing. MacDon Industries, Ltd. makes no representation or warranty of any kind, whether expressed or implied, with respect to the information in this publication. MacDon Industries, Ltd. reserves the right to make changes at any time without notice.



# Declaration of Conformity

	<h2 style="margin: 0;">EC Declaration of Conformity</h2>
<p>[1] <b>MacDon</b>                  MacDon Industries Ltd.                  680 Moray Street,                  Winnipeg, Manitoba, Canada                  R3J 3S3</p>	<p>[4] As per Shipping Document</p> <p>[5] February 21, 2024</p>
<p>[2] Combine Header</p> <p>[3] MacDon FD2 Series</p>	<p>[6] _____                  Adrienne Tankeu                  Product Integrity</p>

EN	BG	CZ	DA
<p>We, [1]</p> <p>Declare, that the product:</p> <p>Machine Type: [2]</p> <p>Name &amp; Model: [3]</p> <p>Serial Number(s): [4]</p> <p>fulfils all the relevant provisions of the Directive 2006/42/EC.</p> <p>Harmonized standards used, as referred to in Article 7(2):</p> <p style="padding-left: 20px;">EN ISO 4254-1:2013 EN ISO 4254-7:2009</p> <p>Place and date of declaration: [5]</p> <p>Identity and signature of the person empowered to draw up the declaration: [6]</p> <p>Name and address of the person authorized to compile the technical file:</p> <p>Guillaume Quenot                      General Manager, MacDon Europe GmbH                      Hagenauer Straße 59                      65203 Wiesbaden (Germany)                      gquenot@macdon.com</p>	<p>Ние, [1]</p> <p>декларираме, че следният продукт:</p> <p>Тип машина: [2]</p> <p>Наименование и модел: [3]</p> <p>Сериен номер(а) [4]</p> <p>отговаря на всички приложими разпоредби на директива 2006/42/ЕО.</p> <p>Използвани са следните хармонизирани стандарти според чл. 7(2):</p> <p style="padding-left: 20px;">EN ISO 4254-1:2013 EN ISO 4254-7:2009</p> <p>Място и дата на декларацията: [5]</p> <p>Име и подпис на лицето, упълномощено да изготви декларацията: [6]</p> <p>Име и адрес на лицето, упълномощено да състави техническия файл:</p> <p>Гуillaume Явенот                      Управител, MacDon Europe GmbH                      Hagenauer Straße 59                      65203 Wiesbaden (Германия)                      gquenot@macdon.com</p>	<p>My, [1]</p> <p>Prohláším, že produkt:</p> <p>Typ zařízení: [2]</p> <p>Název a model: [3]</p> <p>Sériové(á) číslo(a): [4]</p> <p>splňuje všechna relevantní ustanovení směrnice 2006/42/EC.</p> <p>Byly použity harmonizované standardy, jak je uvedeno v článku 7(2):</p> <p style="padding-left: 20px;">EN ISO 4254-1:2013 EN ISO 4254-7:2009</p> <p>Místo a datum prohlášení: [5]</p> <p>Identita a podpis osoby oprávněné k vydání prohlášení: [6]</p> <p>Jméno a adresa osoby oprávněné k vyplnění technického souboru:</p> <p>Guillaume Quenot                      generální ředitel, MacDon Europe GmbH                      Hagenauer Straße 59                      65203 Wiesbaden (Německo)                      gquenot@macdon.com</p>	<p>Vi, [1]</p> <p>erklærer, at produkt:</p> <p>Maskintype [2]</p> <p>Navn og model: [3]</p> <p>Serienummer (-numre): [4]</p> <p>Opfylder alle bestemmelser i direktiv 2006/42/EF.</p> <p>Anvendte harmoniserede standarder, som henviser til i paragraf 7(2):</p> <p style="padding-left: 20px;">EN ISO 4254-1:2013 EN ISO 4254-7:2009</p> <p>Sted og dato for erklæringen: [5]</p> <p>Identitet på og underskrift fra den person, som er bemyndiget til at udarbejde erklæringen: [6]</p> <p>Navn og adresse på den person, som er bemyndiget til at udarbejde den tekniske fil:</p> <p>Guillaume Quenot                      Direktør, MacDon Europe GmbH                      Hagenauer Straße 59                      D-65203 Wiesbaden (Tyskland)                      gquenot@macdon.com</p>

DE	ES	ET	FR
<p>Wir, [1]</p> <p>Erklären hiermit, dass das Produkt:</p> <p>Maschinentyp: [2]</p> <p>Name &amp; Modell: [3]</p> <p>Seriennummer (n): [4]</p> <p>alle relevanten Vorschriften der Richtlinie 2006/42/EG erfüllt.</p> <p>Harmonisierte Standards wurden, wie in folgenden Artikeln angegeben, verwendet 7(2):</p> <p style="padding-left: 20px;">EN ISO 4254-1:2013 EN ISO 4254-7:2009</p> <p>Ort und Datum der Erklärung: [5]</p> <p>Name und Unterschrift der Person, die dazu befugt ist, die Erklärung auszustellen: [6]</p> <p>Name und Anschrift der Person, die dazu berechtigt ist, die technischen Unterlagen zu erstellen:</p> <p>Guillaume Quenot                      General Manager, MacDon Europe GmbH                      Hagenauer Straße 59                      65203 Wiesbaden (Alemania)                      gquenot@macdon.com</p>	<p>Nosotros [1]</p> <p>declaramos que el producto:</p> <p>Tipo de máquina: [2]</p> <p>Nombre y modelo: [3]</p> <p>Números de serie: [4]</p> <p>cumple con todas las disposiciones pertinentes de la directriz 2006/42/EC.</p> <p>Se utilizaron normas armonizadas, según lo dispuesto en el artículo 7(2):</p> <p style="padding-left: 20px;">EN ISO 4254-1:2013 EN ISO 4254-7:2009</p> <p>Lugar y fecha de la declaración: [5]</p> <p>Identidad y firma de la persona facultada para dar redactar la declaración: [6]</p> <p>Nombre y dirección de la persona autorizada para elaborar el expediente técnico:</p> <p>Guillaume Quenot                      Gerente general - MacDon Europe GmbH                      Hagenauer Straße 59                      65203 Wiesbaden (Alemania)                      gquenot@macdon.com</p>	<p>Meie, [1]</p> <p>deklareerime, et toode</p> <p>Seadme tüüp: [2]</p> <p>Nimi ja mudel: [3]</p> <p>Seerianumbrid: [4]</p> <p>vastab kõigile direktiivi 2006/42/EÜ asjakohastele sätetele.</p> <p>Kasutatud on järgnevaid harmoniseeritud standardeid, millele on viidatud ka punktis 7(2):</p> <p style="padding-left: 20px;">EN ISO 4254-1:2013 EN ISO 4254-7:2009</p> <p>Deklaratsiooni koht ja kuupäev: [5]</p> <p>Deklaratsiooni koostamiseks volitatud isiku nimi ja allkiri: [6]</p> <p>Tehnilise dokumendi koostamiseks volitatud isiku nimi ja aadress:</p> <p>Guillaume Quenot                      Peadirektor, MacDon Europe GmbH                      Hagenauer Straße 59                      65203 Wiesbaden (Saksamaa)                      gquenot@macdon.com</p>	<p>Nous soussignés, [1]</p> <p>Déclarons que le produit :</p> <p>Type de machine : [2]</p> <p>Nom et modèle : [3]</p> <p>Numéro(s) de série : [4]</p> <p>Est conforme à toutes les dispositions pertinentes de la directive 2006/42/EC.</p> <p>Utilisation des normes harmonisées, comme indiqué dans l'Article 7(2):</p> <p style="padding-left: 20px;">EN ISO 4254-1:2013 EN ISO 4254-7:2009</p> <p>Lieu et date de la déclaration : [5]</p> <p>Identité et signature de la personne ayant reçu le pouvoir de rédiger cette déclaration : [6]</p> <p>Nom et adresse de la personne autorisée à constituer le dossier technique :</p> <p>Guillaume Quenot                      Directeur général, MacDon Europe GmbH                      Hagenauer Straße 59                      65203 Wiesbaden (Allemagne)                      gquenot@macdon.com</p>

# EC Declaration of Conformity

IT	HU	LT	LV
<p>Noi, [1] Dichiariamo che il prodotto: Tipo di macchina: [2] Nome e modello: [3] Numero(i) di serie: [4] soddisfa tutte le disposizioni rilevanti della direttiva 2006/42/CE.</p> <p>Utilizzo degli standard armonizzati, come indicato nell'Articolo 7(2):</p> <p style="text-align: center;">EN ISO 4254-1:2013 EN ISO 4254-7:2009</p> <p>Luogo e data della dichiarazione: [5] Nome e firma della persona autorizzata a redigere la dichiarazione: [6] Nome e persona autorizzata a compilare il file tecnico: Guillaume Quenot General Manager, MacDon Europe GmbH Hagenauer Straße 59 65203 Wiesbaden (Germania) gquenot@macdon.com</p>	<p>Mi, [1] Ezennel kijelentjük, hogy a következő termék: Gép típusa: [2] Név és modell: [3] Szériaszám(ok): [4] teljesíti a következő irányelv összes vonatkozó előírásait: 2006/42/EK.</p> <p>Az alábbi harmonizált szabványok kerültek alkalmazásra a 7(2) cikkely szerint:</p> <p style="text-align: center;">EN ISO 4254-1:2013 EN ISO 4254-7:2009</p> <p>A nyilatkozattétel ideje és helye: [5] Azon személy kiléte és aláírása, aki jogosult a nyilatkozat elkészítésére: [6] Azon személy neve és aláírása, aki felhatalmazott a műszaki dokumentáció összeállítására: Guillaume Quenot Vezetőigazgató, MacDon Europe GmbH Hagenauer Straße 59 65203 Wiesbaden (Németország) gquenot@macdon.com</p>	<p>Mes, [1] Pareiškiami, kad šis produktas: Mašinos tipas: [2] Pavadinimas ir modelis: [3] Serijos numeris (-iai): [4] atitinka taikomus reikalavimus pagal Direktyvą 2006/42/EB.</p> <p>Naudojami harmonizuoti standartai, kai nurodoma straipsnyje 7(2):</p> <p style="text-align: center;">EN ISO 4254-1:2013 EN ISO 4254-7:2009</p> <p>Deklaracijos vieta ir data: [5] Asmens tapatybės duomenys ir parašas asmens, įgalioto sudaryti šią deklaraciją: [6] Vardas ir pavardė asmens, kuris įgaliotas sudaryti šį techninį failą: Guillaume Quenot Generalinis direktorius, MacDon Europe GmbH Hagenauer Straße 59 65203 Wiesbaden (Vokietija) gquenot@macdon.com</p>	<p>Mēs, [1] Deklarējam, ka produkts: Mašīnas tips: [2] Nosaukums un modelis: [3] Sērijas numurs(-i): [4] Atbilst visām būtiskajām Direktīvas 2006/42/EK prasībām.</p> <p>Piemēroti šādi saskaņotie standarti, kā minēts 7. pantā 2. punktā:</p> <p style="text-align: center;">EN ISO 4254-1:2013 EN ISO 4254-7:2009</p> <p>Deklarācijas parakstīšanas vieta un datums: [5] Tās personas vārds, uzvārds un paraksts, kas ir pilnvarota sagatavot šo deklarāciju: [6] Tās personas vārds, uzvārds un adrese, kas ir pilnvarota sastādīt tehnisko dokumentāciju: Guillaume Quenot Generāldirektors, MacDon Europe GmbH Hagenauer Straße 59 65203 Wiesbaden (Vācija) gquenot@macdon.com</p>
<p>Wij, [1] Verklaren dat het product: Machinetype: [2] Naam en model: [3] Serienummer(s): [4] voldoet aan alle relevante bepalingen van de Richtlijn 2006/42/EC.</p> <p>Geharmoniseerde normen toegepast, zoals vermeld in Artikel 7(2):</p> <p style="text-align: center;">EN ISO 4254-1:2013 EN ISO 4254-7:2009</p> <p>Plaats en datum van verklaring: [5] Naam en handtekening van de bevoegde persoon om de verklaring op te stellen: [6] Naam en adres van de geautoriseerde persoon om het technisch dossier samen te stellen: Guillaume Quenot Algemeen directeur, MacDon Europe GmbH Hagenauer Straße 59 65203 Wiesbaden (Duitsland) gquenot@macdon.com</p>	<p>My niżej podpisani, [1] Oświadczamy, że produkt: Typ urządzenia: [2] Nazwa i model: [3] Numer seryjny/numery seryjne: [4] spełnia wszystkie odpowiednie przepisy dyrektywy 2006/42/WE.</p> <p>Zastosowaliśmy następujące (zharmonizowane) normy zgodnie z artykułem 7(2):</p> <p style="text-align: center;">EN ISO 4254-1:2013 EN ISO 4254-7:2009</p> <p>Data i miejsce oświadczenia: [5] Imię i nazwisko oraz podpis osoby upoważnionej do przygotowania deklaracji: [6] Imię i nazwisko oraz adres osoby upoważnionej do przygotowania dokumentacji technicznej: Guillaume Quenot Dyrektor generalny, MacDon Europe GmbH Hagenauer Straße 59 65203 Wiesbaden (Niemcy) gquenot@macdon.com</p>	<p>Nós, [1] Declarámos, que o produto: Tipo de máquina: [2] Nome e Modelo: [3] Número(s) de Série: [4] cumpre todas as disposições relevantes da Directiva 2006/42/CE.</p> <p>Normas harmonizadas aplicadas, conforme referido no Artigo 7(2):</p> <p style="text-align: center;">EN ISO 4254-1:2013 EN ISO 4254-7:2009</p> <p>Local e data da declaração: [5] Identidade e assinatura da pessoa autorizada a elaborar a declaração: [6] Nome e endereço da pessoa autorizada a compilar o ficheiro técnico: Guillaume Quenot Gerente Geral, MacDon Europa Ltda. Hagenauer Straße 59 65203 Wiesbaden (Alemanha) gquenot@macdon.com</p>	<p>Noi, [1] Declarăm, că următorul produs: Tipul mașinii: [2] Denumirea și modelul: [3] Număr (numere) serie: [4] corespunde tuturor dispozițiilor esențiale ale directivei 2006/42/EC.</p> <p>Au fost aplicate următoarele standarde armonizate conform articolului 7(2):</p> <p style="text-align: center;">EN ISO 4254-1:2013 EN ISO 4254-7:2009</p> <p>Data și locul declarației: [5] Identitatea și semnătura persoanei împuternicite pentru întocmirea declarației: [6] Numele și semnătura persoanei autorizate pentru întocmirea cărții tehnice: Guillaume Quenot Manager General, MacDon Europe GmbH Hagenauer Straße 59 65203 Wiesbaden (Germania) gquenot@macdon.com</p>
<p>Mi, [1] Izjavljujemo da proizvod Tip mašine: [2] Naziv i model: [3] Serijski broj(ovi): [4] Ispunjava sve relevantne odredbe direktive 2006/42/EC.</p> <p>Korišćeni su usklađeni standardi kao što je navedeno u članu 7(2):</p> <p style="text-align: center;">EN ISO 4254-1:2013 EN ISO 4254-7:2009</p> <p>Datum i mesto izdavanja deklaracije: [5] Identitet i potpis lica ovlašćenog za sastavljanje deklaracije: [6] Ime i adresa osobe ovlašćene za sastavljanje tehničke datoteke: Guillaume Quenot Generalni direktor, MacDon Europe GmbH Hagenauer Straße 59 65203 Wiesbaden (Nemačka) gquenot@macdon.com</p>	<p>Mi, [1] Intygat att produkten: Maskintyp: [2] Namn och modell: [3] Serienummer: [4] uppfyller alla relevanta villkor i direktivet 2006/42/EG.</p> <p>Harmonierade standarder används, såsom anges i artikel 7(2):</p> <p style="text-align: center;">EN ISO 4254-1:2013 EN ISO 4254-7:2009</p> <p>Plats och datum för intyget: [5] Identitet och signatur för person med befogenhet att upprätta intyget: [6] Namn och adress för person behörig att upprätta den tekniska dokumentationen: Guillaume Quenot Administrativ chef, MacDon Europe GmbH Hagenauer Straße 59 65203 Wiesbaden (Tyskland) gquenot@macdon.com</p>	<p>Mi, [1] izjavljamo, da izdelek: Vrsta stroja: [2] Ime in model: [3] Serijska/-e številka/-e: [4] ustreza vsem zadevnim določbam Direktive 2006/42/ES.</p> <p>Uporabljeni usklajeni standardi, kot je navedeno v členu 7(2):</p> <p style="text-align: center;">EN ISO 4254-1:2013 EN ISO 4254-7:2009</p> <p>Kraj in datum izjave: [5] Istovetnost in podpis osebe, opolnomočene za pripravo izjave: [6] Ime in naslov osebe, pooblaščenca za pripravo tehnične datoteke: Guillaume Quenot Generalni direktor, MacDon Europe GmbH Hagenauer Straße 59 65203 Wiesbaden (Nemčija) gquenot@macdon.com</p>	<p>My, [1] týmto prehlasujeme, že tento výrobok: Typ zariadenia: [2] Názov a model: [3] Výrobné číslo: [4] splňa príslušné ustanovenia a základné požiadavky smernice č. 2006/42/ES.</p> <p>Použitie harmonizované normy, ktoré sa uvádzajú v článku č. 7(2):</p> <p style="text-align: center;">EN ISO 4254-1:2013 EN ISO 4254-7:2009</p> <p>Miesto a dátum prehlásenia: [5] Meno a podpis osoby oprávnenej vypracovať toto prehlásenie: [6] Meno a adresa osoby oprávnenej zostaviť technický súbor: Guillaume Quenot Generálny riaditeľ MacDon Europe GmbH Hagenauer Straße 59 65203 Wiesbaden (Nemecko) gquenot@macdon.com</p>



# EC Declaration of Conformity

[1] **MacDon**

MacDon Industries Ltd.  
680 Moray Street,  
Winnipeg, Manitoba, Canada  
R3J 3S3

[4] As per Shipping Document

[5] February 21, 2024

[2] Float Module

[6] \_\_\_\_\_

[3] MacDon FM200

Adrienne Tankeu  
Product Integrity

EN	BG	CZ	DA
We, [1] Declare, that the product: Machine Type: [2] Name & Model: [3] Serial Number(s): [4] fulfils all the relevant provisions of the Directive 2006/42/EC. Harmonized standards used, as referred to in Article 7(2): EN ISO 4254-1:2013 EN ISO 4254-7:2009 Place and date of declaration: [5] Identity and signature of the person empowered to draw up the declaration: [6] Name and address of the person authorized to compile the technical file: Guillaume Quenot General Manager, MacDon Europe GmbH Hagenauer Straße 59 65203 Wiesbaden (Germany) gquenot@macdon.com	Ние, [1] декларираме, че следният продукт: Тип машина: [2] Наименование и модел: [3] Серийн номер(а) [4] отговаря на всички приложими разпоредби на директива 2006/42/ЕО. Използвани са следните хармонизирани стандарти според чл. 7(2): EN ISO 4254-1:2013 EN ISO 4254-7:2009 Място и дата на декларацията: [5] Име и подпис на лицето, упълномощено да изготви декларацията: [6] Име и адрес на лицето, упълномощено да състави техническия файл: Гуиллауме Яуенот Управител, MacDon Europe GmbH Hagenauer Straße 59 65203 Wiesbaden (Германия) gquenot@macdon.com	My, [1] Prohlašujeme, že produkt: Typ zařízení: [2] Název a model: [3] Sériové(á) číslo(a): [4] splňuje všechna relevantní ustanovení směrnice 2006/42/EC. Byly použity harmonizované standardy, jak je uvedeno v článku 7(2): EN ISO 4254-1:2013 EN ISO 4254-7:2009 Místo a datum prohlášení: [5] Identita a podpis osoby oprávněné k vydání prohlášení: [6] Jméno a adresa osoby oprávněné k vyplnění technického souboru: Guillaume Quenot generální ředitel, MacDon Europe GmbH Hagenauer Straße 59 65203 Wiesbaden (Německo) gquenot@macdon.com	Vi, [1] erklærer, at produktet: Maskintype [2] Navn og model: [3] Serienummer (-numre): [4] Opfylder alle bestemmelser i direktiv 2006/42/EF. Anvendte harmoniserede standarder, som henviser til i paragraf 7(2): EN ISO 4254-1:2013 EN ISO 4254-7:2009 Sted og dato for erklæringen: [5] Identitet på og underskrift fra den person, som er bemyndiget til at udarbejde erklæringen: [6] Navn og adresse på den person, som er bemyndiget til at udarbejde den tekniske fil: Guillaume Quenot Direktør, MacDon Europe GmbH Hagenauer Straße 59 D-65203 Wiesbaden (Tyskland) gquenot@macdon.com

DE	ES	ET	FR
Wir, [1] Erklären hiermit, dass das Produkt: Maschinentyp: [2] Name & Modell: [3] Seriennummer (n): [4] alle relevanten Vorschriften der Richtlinie 2006/42/EG erfüllt. Harmonisierte Standards wurden, wie in folgenden Artikeln angegeben, verwendet 7(2): EN ISO 4254-1:2013 EN ISO 4254-7:2009 Ort und Datum der Erklärung: [5] Name und Unterschrift der Person, die dazu befugt ist, die Erklärung auszustellen: [6] Name und Anschrift der Person, die dazu berechtigt ist, die technischen Unterlagen zu erstellen: Guillaume Quenot General Manager, MacDon Europe GmbH Hagenauer Straße 59 65203 Wiesbaden gquenot@macdon.com	Nosotros [1] declaramos que el producto: Tipo de máquina: [2] Nombre y modelo: [3] Números de serie: [4] cumple con todas las disposiciones pertinentes de la directriz 2006/42/EC. Se utilizaron normas armonizadas, según lo dispuesto en el artículo 7(2): EN ISO 4254-1:2013 EN ISO 4254-7:2009 Lugar y fecha de la declaración: [5] Identidad y firma de la persona facultada para draw redactar la declaración: [6] Nombre y dirección de la persona autorizada para elaborar el expediente técnico: Guillaume Quenot Gerente general - MacDon Europe GmbH Hagenauer Straße 59 65203 Wiesbaden (Alemania) gquenot@macdon.com	Meie, [1] deklareerime, et toode Seadme tüüp: [2] Nimi ja mudel: [3] Seerianumbrid: [4] vastab kõigile direktiivi 2006/42/EÜ asjakohastele sätetele. Kasutatud on järgnevald harmoniseeritud standardeid, millele on viidatud ka punktis 7(2): EN ISO 4254-1:2013 EN ISO 4254-7:2009 Deklaratsiooni koht ja kuupäev: [5] Deklaratsiooni koostamiseks volitatud isiku nimi ja allkiri: [6] Tehnilise dokumendi koostamiseks volitatud isiku nimi ja aadress: Guillaume Quenot Peadirektor, MacDon Europe GmbH Hagenauer Straße 59 65203 Wiesbaden (Saksamaa) gquenot@macdon.com	Nous soussignés, [1] Déclarons que le produit : Type de machine : [2] Nom et modèle : [3] Numéro(s) de série : [4] Est conforme à toutes les dispositions pertinentes de la directive 2006/42/EC. Utilisation des normes harmonisées, comme indiqué dans l'Article 7(2): EN ISO 4254-1:2013 EN ISO 4254-7:2009 Lieu et date de la déclaration : [5] Identité et signature de la personne ayant reçu le pouvoir de rédiger cette déclaration : [6] Nom et adresse de la personne autorisée à constituer le dossier technique : Guillaume Quenot Directeur général, MacDon Europe GmbH Hagenauer Straße 59 65203 Wiesbaden (Allemagne) gquenot@macdon.com

# EC Declaration of Conformity

IT	HU	LT	LV
<p>Noi, [1] Dichiariamo che il prodotto: Tipo di macchina: [2] Nome e modello: [3] Numero(i) di serie: [4] soddisfa tutte le disposizioni rilevanti della direttiva 2006/42/CE.</p> <p>Utilizzo degli standard armonizzati, come indicato nell'Articolo 7(2):</p> <p style="text-align: center;">EN ISO 4254-1:2013 EN ISO 4254-7:2009</p> <p>Luogo e data della dichiarazione: [5] Nome e firma della persona autorizzata a redigere la dichiarazione: [6] Nome e persona autorizzata a compilare il file tecnico: Guillaume Quenot General Manager, MacDon Europe GmbH Hagenauer Straße 59 65203 Wiesbaden (Germania) gquenot@macdon.com</p>	<p>Mi, [1] Ezennel kijelentjük, hogy a következő termék: Gép típusa: [2] Név és modell: [3] Szériaszám(ok): [4] teljesíti a következő irányelv összes vonatkozó előírásait: 2006/42/EK.</p> <p>Az alábbi harmonizált szabványok kerültek alkalmazásra a 7(2) cikkely szerint:</p> <p style="text-align: center;">EN ISO 4254-1:2013 EN ISO 4254-7:2009</p> <p>A nyilatkozattétel ideje és helye: [5] Azon személy kiléte és aláírása, aki jogosult a nyilatkozat elkészítésére: [6] Azon személy neve és aláírása, aki felhatalmazott a műszaki dokumentáció összeállítására: Guillaume Quenot Vezetőigazgató, MacDon Europe GmbH Hagenauer Straße 59 65203 Wiesbaden (Németország) gquenot@macdon.com</p>	<p>Mes, [1] Pareiškiami, kad šis produktas: Mašinos tipas: [2] Pavadinimas ir modelis: [3] Serijos numeris (-iai): [4] atitinka taikomus reikalavimus pagal Direktyvą 2006/42/EB.</p> <p>Naudojami harmonizuoti standartai, kai nurodoma straipsnyje 7(2):</p> <p style="text-align: center;">EN ISO 4254-1:2013 EN ISO 4254-7:2009</p> <p>Deklaracijos vieta ir data: [5] Asmens tapatybės duomenys ir parašas asmens, įgalioto sudaryti šią deklaraciją: [6] Vardas ir pavardė asmens, kuris įgaliotas sudaryti šį techninį failą: Guillaume Quenot Generalinis direktorius, MacDon Europe GmbH Hagenauer Straße 59 65203 Wiesbaden (Vokietija) gquenot@macdon.com</p>	<p>Mēs, [1] Deklarējam, ka produkts: Mašīnas tips: [2] Nosaukums un modelis: [3] Sērijas numurs(-i): [4] Atbilst visām būtiskajām Direktīvas 2006/42/EK prasībām.</p> <p>Piemēroti šādi saskaņotie standarti, kā minēts 7. pantā 2. punktā:</p> <p style="text-align: center;">EN ISO 4254-1:2013 EN ISO 4254-7:2009</p> <p>Deklarācijas parakstīšanas vieta un datums: [5] Tās personas vārds, uzvārds un paraksts, kas ir pilnvarota sagatavot šo deklarāciju: [6] Tās personas vārds, uzvārds un adrese, kas ir pilnvarota sastādīt tehnisko dokumentāciju: Guillaume Quenot Generāldirektors, MacDon Europe GmbH Hagenauer Straße 59 65203 Wiesbaden (Vācija) gquenot@macdon.com</p>
<p>Wij, [1] Verklaren dat het product: Machinetype: [2] Naam en model: [3] Serienummer(s): [4] voldoet aan alle relevante bepalingen van de Richtlijn 2006/42/EC.</p> <p>Geharmoniseerde normen toegepast, zoals vermeld in Artikel 7(2):</p> <p style="text-align: center;">EN ISO 4254-1:2013 EN ISO 4254-7:2009</p> <p>Plaats en datum van verklaring: [5] Naam en handtekening van de bevoegde persoon om de verklaring op te stellen: [6] Naam en adres van de geautoriseerde persoon om het technisch dossier samen te stellen: Guillaume Quenot Algemeen directeur, MacDon Europe GmbH Hagenauer Straße 59 65203 Wiesbaden (Duitsland) gquenot@macdon.com</p>	<p>My niżej podpisani, [1] Oświadczamy, że produkt: Typ urządzenia: [2] Nazwa i model: [3] Numer seryjny/numery seryjne: [4] spełnia wszystkie odpowiednie przepisy dyrektywy 2006/42/WE.</p> <p>Zastosowaliśmy następujące (zharmonizowane) normy zgodnie z artykułem 7(2):</p> <p style="text-align: center;">EN ISO 4254-1:2013 EN ISO 4254-7:2009</p> <p>Data i miejsce oświadczenia: [5] Imię i nazwisko oraz podpis osoby upoważnionej do przygotowania deklaracji: [6] Imię i nazwisko oraz adres osoby upoważnionej do przygotowania dokumentacji technicznej: Guillaume Quenot Dyrektor generalny, MacDon Europe GmbH Hagenauer Straße 59 65203 Wiesbaden (Niemcy) gquenot@macdon.com</p>	<p>Nós, [1] Declarámos, que o produto: Tipo de máquina: [2] Nome e Modelo: [3] Número(s) de Série: [4] cumpre todas as disposições relevantes da Directiva 2006/42/CE.</p> <p>Normas harmonizadas aplicadas, conforme referido no Artigo 7(2):</p> <p style="text-align: center;">EN ISO 4254-1:2013 EN ISO 4254-7:2009</p> <p>Local e data da declaração: [5] Identidade e assinatura da pessoa autorizada a elaborar a declaração: [6] Nome e endereço da pessoa autorizada a compilar o ficheiro técnico: Guillaume Quenot Gerente Geral, MacDon Europa Ltda. Hagenauer Straße 59 65203 Wiesbaden (Alemanha) gquenot@macdon.com</p>	<p>Noi, [1] Declarăm, că următorul produs: Tipul mașinii: [2] Denumirea și modelul: [3] Număr (numere) serie: [4] corespunde tuturor dispozițiilor esențiale ale directivei 2006/42/EC.</p> <p>Au fost aplicate următoarele standarde armonizate conform articolului 7(2):</p> <p style="text-align: center;">EN ISO 4254-1:2013 EN ISO 4254-7:2009</p> <p>Data și locul declarației: [5] Identitatea și semnătura persoanei împuternicite pentru întocmirea declarației: [6] Numele și semnătura persoanei autorizate pentru întocmirea cărții tehnice: Guillaume Quenot Manager General, MacDon Europe GmbH Hagenauer Straße 59 65203 Wiesbaden (Germania) gquenot@macdon.com</p>
<p>Mi, [1] Izjavljujemo da proizvod Tip mašine: [2] Naziv i model: [3] Serijski broj(evi): [4] Ispunjava sve relevantne odredbe direktive 2006/42/EC.</p> <p>Korišćeni su usklađeni standardi kao što je navedeno u članu 7(2):</p> <p style="text-align: center;">EN ISO 4254-1:2013 EN ISO 4254-7:2009</p> <p>Datum i mesto izdavanja deklaracije: [5] Identitet i potpis lica ovlašćenog za sastavljanje deklaracije: [6] Ime i adresa osobe ovlašćene za sastavljanje tehničke datoteke: Guillaume Quenot Generalni direktor, MacDon Europe GmbH Hagenauer Straße 59 65203 Wiesbaden (Nemačka) gquenot@macdon.com</p>	<p>Mi, [1] Intygat att produkten: Maskintyp: [2] Namn och modell: [3] Serienummer: [4] uppfyller alla relevanta villkor i direktivet 2006/42/EG.</p> <p>Harmonierade standarder används, såsom anges i artikel 7(2):</p> <p style="text-align: center;">EN ISO 4254-1:2013 EN ISO 4254-7:2009</p> <p>Plats och datum för intyget: [5] Identitet och signatur för person med befogenhet att upprätta intyget: [6] Namn och adress för person behörig att upprätta den tekniska dokumentationen: Guillaume Quenot Administrativ chef, MacDon Europe GmbH Hagenauer Straße 59 65203 Wiesbaden (Tyskland) gquenot@macdon.com</p>	<p>Mi, [1] izjavljamo, da izdelek: Vrsta stroja: [2] Ime in model: [3] Serijska/-e številka/-e: [4] ustreza vsem zadevnim določbam Direktive 2006/42/ES.</p> <p>Uporabljeni usklajeni standardi, kot je navedeno v členu 7(2):</p> <p style="text-align: center;">EN ISO 4254-1:2013 EN ISO 4254-7:2009</p> <p>Kraj in datum izjave: [5] Istovetnost in podpis osebe, opolnomočene za pripravo izjave: [6] Ime in naslov osebe, pooblaščenca za pripravo tehnične datoteke: Guillaume Quenot Generalni direktor, MacDon Europe GmbH Hagenauer Straße 59 65203 Wiesbaden (Nemčija) gquenot@macdon.com</p>	<p>My, [1] týmto prehlasujeme, že tento výrobok: Typ zariadenia: [2] Názov a model: [3] Výrobné číslo: [4] splňa príslušné ustanovenia a základné požiadavky smernice č. 2006/42/ES.</p> <p>Použitie harmonizované normy, ktoré sa uvádzajú v článku č. 7(2):</p> <p style="text-align: center;">EN ISO 4254-1:2013 EN ISO 4254-7:2009</p> <p>Miesto a dátum prehlásenia: [5] Meno a podpis osoby oprávnenej vypracovať toto prehlásenie: [6] Meno a adresa osoby oprávnenej zostaviť technický súbor: Guillaume Quenot Generálny riaditeľ MacDon Europe GmbH Hagenauer Straße 59 65203 Wiesbaden (Nemecko) gquenot@macdon.com</p>



## UK Declaration of Conformity

[1] **MacDon**

MacDon Industries Ltd.  
680 Moray Street,  
Winnipeg, Manitoba, Canada  
R3J 3S3

[4] As per Shipping Document

[5] May 4, 2023

[2] Combine Header

[6] \_\_\_\_\_

[3] MacDon FD2 Series

Adrienne Tankeu  
Product Integrity

We, [1]

Declare, that the product:

Machine Type: [2]

Name & Model: [3]

Serial Number(s): [4]

fulfills all relevant provisions of the Supply of Machinery (Safety) Regulations 2008

Designated standards used are :

EN ISO 4254-1:2015

EN ISO 4254-7:2017

Place and date of declaration: [5]

Identity and signature of the person empowered to draw up the declaration: [6]



## UK Declaration of Conformity

- [1] **MacDon**  
MacDon Industries Ltd.  
680 Moray Street,  
Winnipeg, Manitoba, Canada  
R3J 3S3
- [2] Float Module
- [3] MacDon FM200
- [4] As per Shipping Document
- [5] May 4, 2023
- [6] \_\_\_\_\_  
Adrienne Tankeu  
Product Integrity

We, [1]

Declare, that the product:

Machine Type: [2]

Name & Model: [3]

Serial Number(s): [4]

fulfills all relevant provisions of the Supply of Machinery (Safety) Regulations 2008

Designated standards used are :

EN ISO 4254-1:2015

EN ISO 4254-7:2017

Place and date of declaration: [5]

Identity and signature of the person empowered to draw up the declaration: [6]

## Introduction

This instructional manual contains information on the FD2 Series FlexDraper® Header and the FM200 Float Module. Use it in conjunction with your combine operator's manual.

### ***Your machine***

The FD2 Series FlexDraper® Header is specially designed to work well in all straight cut conditions, whether cutting on or above the ground, using a three-piece flexible frame to closely follow the ground contours. The FM200 Float Module attaches the FD2 Series FlexDraper® Header to most makes and models of combines.

### ***Your warranty***

MacDon provides warranty for Customers who operate and maintain their equipment as described in this manual. A copy of the MacDon Industries Limited Warranty Policy, which explains this warranty, should have been provided to you by your Dealer. Damage resulting from any of the following conditions will void the warranty:

- Accident
- Misuse
- Abuse
- Improper maintenance or neglect
- Abnormal or extraordinary use of the machine
- Failure to use the machine, equipment, component, or part in accordance with the manufacturer's instructions

### ***Your manual***

**Carefully read all of the material provided before attempting to operate the machine.**

Use this manual as your first source of information about the machine. If you follow the instructions provided, your header will work well for many years.

The following conventions are used in this document:

- Right and left are determined from the operator's position. The front of the header faces the crop; the back of the header attaches to the float module and the combine.
- Unless otherwise noted, use the standard torque values provided in Chapter [7.1 Torque Specifications, page 823](#).

When setting up the machine or making any adjustments, review and follow the recommended machine settings in all relevant MacDon publications. Failure to do so may compromise machine function and machine life and may result in a hazardous situation.

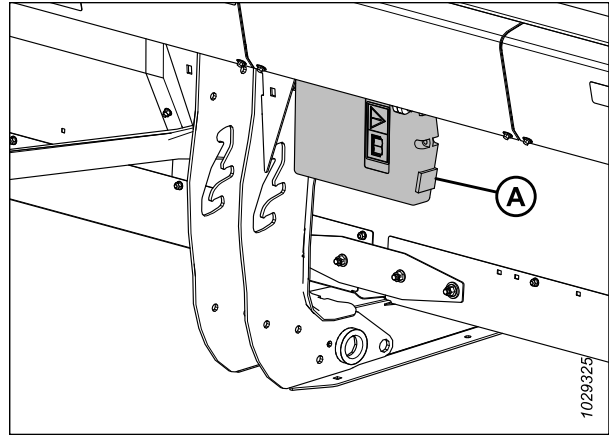
The Table of Contents and the Index will guide you to specific areas in this manual. Study the Table of Contents to familiarize yourself with how the information is organized.

Keep this manual handy for frequent reference and to pass on to new Operators or Owners. The manual storage case (A) is located at the rear of the header, beside the right outer leg.

**NOTE:**

Keep your MacDon publications up-to-date. The most current English version can be downloaded from our website ([www.macdon.com](http://www.macdon.com)) or from our Dealer-only site (<https://portal.macdon.com>) (login required).

Call your MacDon Dealer if you need assistance, information, or additional copies of this manual.



**Figure 1: Manual Storage Location**

This manual is available in the following languages:

- Bulgarian
- Czech
- Danish
- English
- Estonian
- French
- German
- Hungarian
- Italian
- Latvian
- Lithuanian
- Polish
- Portuguese
- Romanian
- Russian
- Spanish
- Ukrainian

These manuals can be ordered from MacDon, downloaded from the MacDon Dealer Portal (<https://portal.macdon.com>) (login required), or downloaded from the MacDon website ([www.macdon.com](http://www.macdon.com)).



## Summary of Changes

The following list provides an account of major changes from the previous version of this document.

Section	Summary of Change	Internal Use Only
<i>Declaration of Conformity, page i</i>	Updated Declaration of Conformity.	Technical Publications
<i>2.1 Definitions, page 27</i>	Added IHS (Integrated hydraulic system) and MHS (Modular hydraulic system)	Technical Publications
<i>2.5 FM200 Float Module Component Identification, page 34</i>	Updated illustration of integrated hydraulic system (IHS) to show new oil level sight glass.	Product Support
<i>2.5 FM200 Float Module Component Identification, page 34</i>	Added new illustrations to show float module with modular hydraulic system (MHS) and to differentiate it from integrated hydraulic system (IHS).	ECN 65226 ECN 65259
<i>Checking and Adjusting Header Endshields, page 44</i>	Revised procedure.	ECN 64181
<i>3.6 Header Attachment/Detachment, page 74</i>	"CLAAS 500 Series" relabeled as "CLAAS/CAT-Lexion Models", and added "600" to the list.	ECR 32134 ECN 64068
<i>Attaching Header to Challenger®, Gleaner®, or Massey Ferguson® Combine, page 83</i>	<ul style="list-style-type: none"> <li>Deleted "Start the engine" step.</li> <li>Illustration 1043218 replaces 1001486 to show the feeder house tool and latch mechanism.</li> <li>Deleted "Lower the header fully" step.</li> <li>Revised the step and illustration about float locks to clarify when the locks should be left locked or unlocked.</li> </ul>	Technical Publications Product Support
<i>3.6.3 CLAAS Combines, page 91</i>	Removed Tucano series combine.	Engineering
<i>Attaching Header to CLAAS Combine, page 92</i>	<ul style="list-style-type: none"> <li>Deleted "Start the engine" step.</li> <li>Deleted "Lower the header fully" step.</li> <li>Deleted "Remove the blocks from under the cutterbar" step.</li> <li>Replaced illustration 1039435 with 1035174. Added the condition "If MacDon in-cab controls are installed" to the step concerning connectors C81A and C81B.</li> <li>Revised the last step to clarify when the float locks should be left locked or unlocked.</li> </ul>	Engineering

Section	Summary of Change	Internal Use Only
<i>Installing Limiter Link and Performing a Fore/Aft Tilt Calibration – CLAAS Lexion 6000, 7000 and 8000 Series, and CLAAS Trion 600 and 700 Series Combines, page 97</i>	Added topic.	Technical Publications Product Support
<i>Attaching Header to IDEAL™ Series Combine, page 105</i>	<ul style="list-style-type: none"> <li>• Deleted “Start the engine” step.</li> <li>• Added “Shut the engine off” step.</li> <li>• Replaced illustration 1038495 with 1043031. Added the step concerning connectors C81A and C81B.</li> <li>• Added the last step to clarify when the float locks should be left locked or unlocked.</li> </ul>	Engineering
<i>Attaching Header to John Deere Combine, page 112</i>	<ul style="list-style-type: none"> <li>• Deleted “Start the engine” step.</li> <li>• Added X9 series one- and two-position adjustment plate content.</li> <li>• Revised steps concerning the attachment of the multicoupler to the combine, and feeder house locking pin engagement.</li> <li>• Revised the last step to clarify when the float locks should be left locked or unlocked.</li> </ul>	Technical Publications ECN 64613
<i>Detaching Header from New Holland CR, CX, or CH Combine, page 128</i>	Added CH model.	Technical Publications
<i>Attaching Header to Rostselmash Combine, page 133</i>	<ul style="list-style-type: none"> <li>• Deleted “Start the engine” step.</li> <li>• Revised the last step to clarify when the float locks should be left locked or unlocked.</li> </ul>	Technical Publications
<i>Checking and Adjusting Header Float, page 210</i>	Added step.	Technical Publications ECN 64338
<i>3.9.10 Knife Speed Information, page 245</i>	Added Rostselmash.	Technical Publications
<i>Checking Knife Speed, page 245</i>	Added Rostselmash.	Technical Publications
<i>Checking and Adjusting Reel Height Sensor, page 248</i>	Added Challenger®, Gleaner®, Massey Ferguson®, and Rostselmash information to the voltage limits table.	Technical Publications
<i>3.9.12 Reel Fore-Aft Position, page 252</i>	Removed D2 header information.	Technical Publications
<ul style="list-style-type: none"> <li>• <i>Checking and Adjusting Fore-Aft Position Sensor Voltage, page 258</i></li> <li>• <i>Checking and Adjusting Fore-Aft Position Sensor Orientation, page 259</i></li> </ul>	Replaced the topic “Checking and Adjusting Reel Fore-Aft Position Sensor” with “Checking and Adjusting Fore-Aft Position Sensor Voltage” and “Checking and Adjusting Fore-Aft Position Sensor Orientation”.	Technical Publications ECN 64090 ECN 65011

Section	Summary of Change	Internal Use Only
<i>3.2 Recommended Sensor Output Voltages for Combines, page 295</i>	Removed all combine model numbers because this was unnecessary detail.	Engineering
<i>3.3 Manually Checking Voltage Limits, page 296</i>	Revised procedure.	Product Support
<i>3.14 John Deere 60 Series Combines, page 431</i>	Added topics for configuring the AHHC system with John Deere 60 Series Combines.	Technical Publications
<i>3.16.6 Calibrating Feeder House Fore-Aft Tilt Range – John Deere S and T Series, Model Year 2015 and Later, page 460</i>	Added “Model Year 2015 and Later” to title.	Technical Publications
<i>3.18 John Deere X9 Series Combines, page 483</i>	Added note about auto-tilt calibration.	Engineering
<i>3.18.2 Calibrating Auto Header Height Control – John Deere X9 Series, page 485</i>	Added step about auto-tilt calibration.	Engineering
<i>3.18.3 Checking Voltage Range from Combine Cab – John Deere X9 Series, page 488</i>	Added last step “If the sensor voltage is not within the lower and upper limits...” for consistency with equivalent procedures for other brands of combine.	Technical Publications
<i>3.21.4 Operating Header – Rostselmash RSM 161, T500, and TORUM 785, page 541</i>	Corrected model numbers in the title.	Engineering
<i>4.2.1 Maintenance Schedule/Record, page 568</i>	Added ContourMax™ wheel grease interval.	Product Support
<i>Every 500 Hours, page 584</i>	Added ContourMax™ wheel to 500-hour grease interval.	Product Support
<i>4.4.1 Checking Oil Level in Hydraulic Reservoir, page 595</i>	Revised step and illustration.	Product Support
<i>4.4.4 Changing Oil Filter, page 597</i>	Added new illustration and steps for the float module with modular hydraulic system (MHS).	ECN 65226 ECN 65259
<i>Checking Oil Level in Knife Drive Box, page 666</i>	Corrected the steps for checking the oil level.	Product Support
<i>4.12.2 Installing Side Drapers, page 700</i>	Added/revised steps.	Product Support
<i>4.13.1 Reel-to-Cutterbar Clearance, page 720</i>	Updated table.	Engineering
<i>Removing Reel Drive Optional Dual Sprocket, page 753</i>	Added topic.	Technical Publications
<i>Installing Reel Drive Optional Dual Sprocket, page 755</i>	Added topic.	Technical Publications
<i>5.4.3 EasyMove™ Transport System, page 802</i>	Updated bundle numbers and collector numbers.	ECN 64895
Throughout	Added reel safety prop hazard statement.	Technical Publications

Section	Summary of Change	Internal Use Only
Throughout	<ul style="list-style-type: none"> <li>Added Trion series to some CLAAS auto header height topics.</li> <li>Edited "CLAAS 5/6/7/8000/TRION Series" to "CLAAS Lexion 6000, 7000, 8000 Series, and CLAAS Trion 600 and 700 Series Combine".</li> </ul>	Engineering
Throughout	Deleted "Start the engine" step at the beginning of procedure.	Technical Publications
Throughout	Replaced header sizes with header models.	Technical Publications
Inside back cover	Gear lubricant capacity corrected from 1.3 quarts to 1.6 quarts.	Technical Publications
-	Removed the topic "Storing the Header" content the same as "Equipment Servicing – End-of-Season".	Technical Publications
-	Deleted duplicate topic "Leveling Contour Wheel Height" from Section 3.9.1, retain the one in Section 4.15.	Technical Publications
-	Removed the topic "Double-Reel or Triple Reel Drive U-Joint".	Product Support
-	Removed the topic "Removing Reel Drive U-Joint – Double-Reel or Triple Reel Drive U-Joint".	Product Support
-	Removed the topic "Installing Double-Reel or Triple Reel U-Joint".	Product Support
-	Removed the topic "Reel Drive Motor".	Product Support
-	Removed the topic "Removing Reel Drive Motor".	Product Support
-	Removed the topic "Installing Reel Drive Motor".	Product Support
-	Removed the topic "Replacing Drive Chain (Endless) – Double and Triple Reel".	Product Support
-	Removed the topic "Leveling Header".	Product Support
-	Removed the topic "Removing Auger Drive Chain".	Product Support
-	Removed the topic "Installing Auger Drive Chain".	Product Support
-	Removed the topic "Remove Knifehead Bearing".	Product Support
-	Removed the topic "Installing Knifehead Bearing".	Product Support

Section	Summary of Change	Internal Use Only
-	Removed "In-Cab Side Draper Speed Control Integration Kit".	Product Support
-	Removed the topic "Checking Software Version of Header Controller – John Deere X9 Series".	Product Support

## Recording Model and Serial Number

Record the model number, serial number, and model year of the header, float module, and transport/stabilizer wheel option (if installed) in the spaces provided.

### FD2 Series FlexDraper® Header

Header Model: \_\_\_\_\_

Serial Number: \_\_\_\_\_

Model Year: \_\_\_\_\_

The header's serial number plate (A) is located on the back of the header, beside the left endsheet.

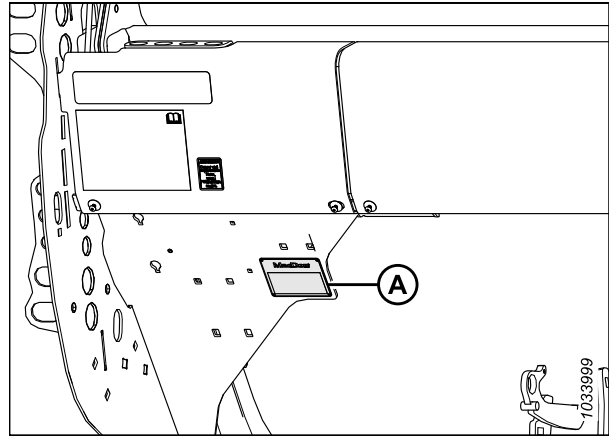


Figure 2: Header Serial Number Plate Location

### FM200 Float Module for Combine

Serial Number: \_\_\_\_\_

Model Year: \_\_\_\_\_

The float module's serial number plate (A) is located on the top left side of the float module.

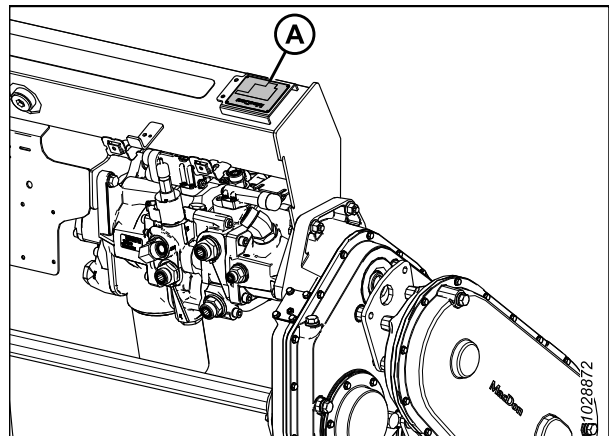


Figure 3: Float Module Serial Number Plate Location

### EasyMove™ Transport Option

Serial Number: \_\_\_\_\_

Model Year: \_\_\_\_\_

The EasyMove™ transport's serial number plate (A) is located on the right axle assembly.

#### NOTE:

The transport is an option and may not be installed on this machine.

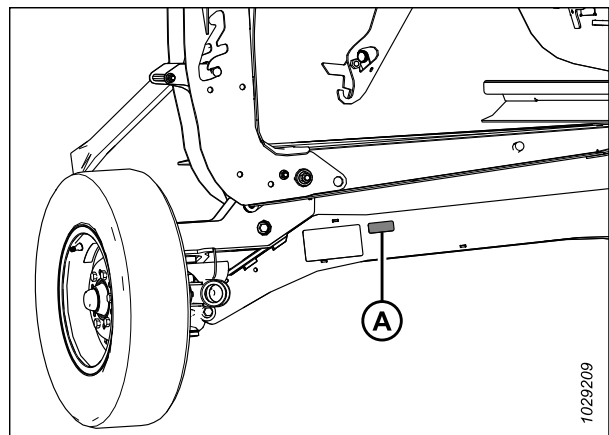


Figure 4: EasyMove™ Transport Option

## TABLE OF CONTENTS

Declaration of Conformity .....	i
Introduction .....	vii
Summary of Changes.....	ix
Recording Model and Serial Number .....	xiv
<b>Chapter 1: Safety .....</b>	<b>1</b>
1.1 Safety Alert Symbols .....	1
1.2 Signal Words .....	2
1.3 General Safety .....	3
1.4 Maintenance Safety .....	5
1.5 Hydraulic Safety .....	7
1.6 Welding Precautions .....	8
1.7 Decommissioning and Disposing of Agricultural Equipment.....	10
1.8 Safety Signs .....	12
1.8.1 Installing Safety Decals.....	12
1.9 Safety Decal Locations.....	13
1.10 Understanding Safety Signs .....	19
<b>Chapter 2: Product Overview .....</b>	<b>27</b>
2.1 Definitions .....	27
2.2 Product Specifications .....	29
2.3 FD2 Series FlexDraper® Header Dimensions.....	32
2.4 FD2 Series FlexDraper® Header Component Identification.....	33
2.5 FM200 Float Module Component Identification .....	34
<b>Chapter 3: Operation .....</b>	<b>37</b>
3.1 Owner/Operator Responsibilities .....	37
3.2 Operational Safety.....	38
3.2.1 Header Safety Props .....	38
3.2.2 Reel Safety Props .....	39
Engaging Reel Safety Props.....	39
Disengaging Reel Safety Props .....	40
3.2.3 Header Endshields .....	41
Opening Header Endshields .....	41
Closing Header Endshields.....	42
Checking and Adjusting Header Endshields.....	44
Removing Header Endshields .....	48
Installing Header Endshields .....	49
3.2.4 Reel Drive Cover .....	49
Removing Reel Drive Cover .....	49
Installing Reel Drive Cover.....	51
3.2.5 Flex Linkage Cover .....	52
Removing Inboard Flex Linkage Covers .....	52
Installing Inboard Flex Linkage Covers .....	53
Removing Outboard Flex Linkage Covers.....	54

## TABLE OF CONTENTS

Installing Outboard Flex Linkage Covers .....	55
3.2.6 Daily Start-Up Check .....	57
<b>3.3 Break-in Period .....</b>	<b>58</b>
<b>3.4 Shutting Down Combine .....</b>	<b>59</b>
<b>3.5 Cab Controls .....</b>	<b>60</b>
3.5.1 CLAAS Series Cab Controls .....	60
Selecting the Default Function for the Multifunction Lever Toggle Switch (with CLAAS Integration Kit) .....	60
Controlling Header Pitch Cylinder .....	62
Controlling Draper Speed – CLAAS 600 and 700 Series .....	62
Controlling Draper Speed – CLAAS 5000, 6000, 7000, and 8000 Series .....	64
Viewing Header Hours .....	65
3.5.2 John Deere X9 Series Cab Controls .....	66
Assigning Ground Speed Lever Buttons – John Deere X9 Series .....	66
Assigning Console Buttons – John Deere X9 Series .....	68
Using Wing Level Function as Tilt Toggle – John Deere X9 Series .....	70
Mapping Draper Speed Controls on Ground Speed Lever – John Deere X9 Series .....	71
Locking/Unlocking Double Tap Tilt Function – John Deere X9 Series .....	72
<b>3.6 Header Attachment/Detachment .....</b>	<b>74</b>
3.6.1 Case IH Combines .....	74
Attaching Header to Case IH Combine .....	74
Detaching Header from Case IH Combine .....	79
3.6.2 Challenger®, Gleaner®, and Massey Ferguson® Combines .....	83
Attaching Header to Challenger®, Gleaner®, or Massey Ferguson® Combine .....	83
Detaching Header from a Challenger®, Gleaner®, or Massey Ferguson® Combine .....	87
3.6.3 CLAAS Combines .....	91
Attaching Header to CLAAS Combine .....	92
Detaching Header from CLAAS Combine .....	101
3.6.4 IDEAL™ Series Combines .....	105
Attaching Header to IDEAL™ Series Combine .....	105
Detaching Header from IDEAL™ Series Combine .....	109
3.6.5 John Deere Combines .....	111
Attaching Header to John Deere Combine .....	112
Detaching Header from John Deere Combine .....	119
3.6.6 New Holland Combines .....	123
Attaching Header to New Holland CR, CX, or CH Combine .....	123
Detaching Header from New Holland CR, CX, or CH Combine .....	128
3.6.7 Rostselmash Combines .....	133
Attaching Header to Rostselmash Combine .....	133
Detaching Header from Rostselmash Combine .....	137
<b>3.7 Header Setup .....</b>	<b>141</b>
3.7.1 Header Attachments .....	141
3.7.2 Header Settings .....	141
3.7.3 Optimizing Header for Straight-Combining Canola .....	152
3.7.4 Reel Settings .....	152
3.7.5 Floating Crop Divider Settings (Optional) .....	155
<b>3.8 Float Module Setup .....</b>	<b>158</b>
3.8.1 FM200 Feed Auger Performance Configurations .....	158



## TABLE OF CONTENTS

Ultra Narrow Configuration – Auger Flighting .....	160
Narrow Configuration – Auger Flighting .....	164
Medium Configuration – Auger Flighting.....	167
Wide Configuration – Auger Flighting .....	169
Ultra Wide Configuration – Auger Flighting .....	172
Auger Flighting .....	174
3.8.2 Removing Feed Auger Fingers .....	181
3.8.3 Installing Feed Auger Fingers.....	184
3.8.4 Setting Auger Position.....	185
3.8.5 Checking and Adjusting Feed Auger Springs .....	187
3.8.6 Stripper Bars .....	188
<b>3.9 Header Operating Variables.....</b>	<b>189</b>
3.9.1 Cutting off Ground .....	189
Adjusting Stabilizer Wheels .....	190
Adjusting EasyMove™ Transport Wheels .....	191
Extending/Retracting Contour Wheels using Foot Switch .....	192
Extending/Retracting Contour Wheels using Integrated Controls – Case and New Holland.....	193
Extending/Retracting Contour Wheels using Integrated Controls – CLAAS Lexion 600/700 Series .....	194
Extending/Retracting Contour Wheels using Integrated Controls – CLAAS Lexion 8000 Series.....	198
Extending/Retracting Contour Wheels using Integrated Controls – John Deere X9 Series.....	201
Leveling Contour Wheel Height .....	204
3.9.2 Cutting on Ground .....	207
Adjusting Inner Skid Shoes .....	207
Adjusting Outer Skid Shoes.....	208
3.9.3 Header Float .....	209
Checking and Adjusting Header Float .....	210
Changing Float Spring Configuration and Installation Location – Float Levers with Two Holes.....	216
Locking / Unlocking Header Float .....	221
Operating in Flex Mode .....	221
Operating in Rigid Mode .....	224
Disabling Flex Frown Limiter .....	225
Enabling Flex Frown Limiter.....	225
3.9.4 Checking and Adjusting Wing Balance.....	226
3.9.5 Header Angle .....	232
Adjusting Header Angle from Combine .....	234
3.9.6 Reel Speed.....	240
Optional Reel Drive Sprockets .....	240
3.9.7 Ground Speed .....	242
3.9.8 Side Draper Speed.....	243
Adjusting Side Draper Speed.....	243
3.9.9 Feed Draper Speed.....	244
3.9.10 Knife Speed Information .....	245
Checking Knife Speed .....	245
3.9.11 Reel Height .....	247
Checking and Adjusting Reel Height Sensor .....	248
Replacing Reel Height Sensor.....	251
3.9.12 Reel Fore-Aft Position .....	252
Adjusting Reel Fore-Aft Position .....	253
Repositioning Fore-Aft Cylinders.....	253
Checking and Adjusting Fore-Aft Position Sensor Voltage.....	258

## TABLE OF CONTENTS

Checking and Adjusting Fore-Aft Position Sensor Orientation .....	259
3.9.13 Reel Tine Pitch .....	261
Reel Cam Settings .....	261
Adjusting Reel Cam .....	263
3.9.14 Upper Cross Auger .....	265
Adjusting Upper Cross Auger Position – Two or Three Piece Augers.....	265
Checking Upper Cross Auger for Interference .....	268
3.9.15 Crop Dividers .....	268
Removing Crop Dividers .....	269
Installing Crop Dividers .....	270
Removing Floating Crop Dividers .....	272
Installing Floating Crop Dividers .....	273
Adjusting Floating Crop Dividers.....	276
3.9.16 Crop Divider Rods.....	287
Removing Crop Divider Rods.....	288
Installing Crop Divider Rods .....	288
Optional Rice Divider Rods .....	289
Auto Header Height Control System.....	290
3.1 Auto Header Height Control Sensor Operation.....	292
3.2 Recommended Sensor Output Voltages for Combines.....	295
3.3 Manually Checking Voltage Limits.....	296
3.4 10 Volt Adapter – New Holland Combines Only.....	300
3.5 Case IH 130 and 140 Series Mid-Range Combines.....	301
3.5.1 Checking Voltage Range from Combine Cab – Case IH 5130, 5140, 6130, 6140, 7130, and 7140.....	301
3.5.2 Header Settings Quick Reference – Case IH 130 and 140 Series .....	303
3.5.3 Setting up Header on Combine Display – Case IH 5130, 5140, 6130, 6140, 7130, and 7140 .....	304
3.5.4 Calibrating Auto Header Height Control – Case IH 5130, 5140, 6130, 6140, 7130, and 7140 Combines with Software Version below 28.00.....	306
3.5.5 Setting Preset Cutting Height – Case IH 5130, 5140, 6130, 6140, 7130, and 7140 .....	309
3.6 Case IH 120, 230, 240, and 250 Series Combines .....	312
3.6.1 Checking Voltage Range from Combine Cab – Case IH, 120, 230, 240, and 250 Series Combines .....	312
3.6.2 Header Settings Quick Reference – Case IH 120, 230, 240, and 250 Series.....	314
3.6.3 Calibrating Auto Header Height Control – Case IH 120, 230, 240, and 250 Series Combines with Software Version below 28.00.....	315
3.6.4 Calibrating Auto Header Height Control – Case IH Combines with Version 28.00 or Higher Software .....	320
3.6.5 Checking Reel Height Sensor Voltages – Case IH Combines .....	326
3.6.6 Setting Preset Cutting Height – Case IH 120, 230, 240, and 250 Series Combines.....	328
3.6.7 Reel Reverse Function – Case IH Combines .....	329
3.6.8 Side Draper Speed Control – Case IH Combines .....	332
3.6.9 Reel Speed Sensor Compatibility – Case IH Combines .....	333
3.7 Challenger® and Massey Ferguson® 6 and 7 Series Combines .....	335
3.7.1 Checking Voltage Range from Combine Cab – Challenger® and Massey Ferguson® .....	335
3.7.2 Engaging Auto Header Height Control – Challenger® and Massey Ferguson® .....	337
3.7.3 Calibrating Auto Header Height Control – Challenger® and Massey Ferguson® .....	338
3.7.4 Adjusting Header Height – Challenger® and Massey Ferguson® .....	341

TABLE OF CONTENTS

3.7.5 Adjusting Header Raise/Lower Rate – Challenger® and Massey Ferguson® ..... 342

3.7.6 Setting Auto Header Height Control Sensitivity – Challenger® and Massey Ferguson® ..... 343

3.8 CLAAS/CAT Lexion 500 Series and Model 600 Combines ..... 345

3.8.1 Calibrating Auto Header Height Control – CLAAS/CAT Lexion 500 series and model 600 combines ..... 345

3.8.2 Cutting Height – CLAAS/CAT Lexion 500 Series and Model 600 Combines ..... 348

3.8.3 Setting Auto Header Height Control Sensitivity – CLAAS/CAT Lexion 500 Series and Model 600  
Combines ..... 350

3.8.4 Adjusting Auto Reel Speed – CLAAS/CAT Lexion 500 Series and Model 600 Combines ..... 353

3.9 CLAAS Lexion 600 and 700 Series Combines ..... 357

3.9.1 Calibrating Auto Header Height Control – CLAAS Lexion 600 and 700 Series ..... 357

3.9.2 Setting Cutting Height – CLAAS Lexion 600 and 700 Series ..... 360

3.9.3 Setting Auto Header Height Control Sensitivity – CLAAS Lexion 600 and 700 Series ..... 361

3.9.4 Adjusting Auto Reel Speed – CLAAS Lexion 600 and 700 Series ..... 362

3.9.5 Calibrating Reel Height Sensor and Reel Fore-Aft Sensor – CLAAS Lexion 600 and 700 Series ..... 364

3.9.6 Adjusting Auto Reel Height – CLAAS Lexion 600 and 700 Series ..... 368

3.10 CLAAS Lexion 6000, 7000 and 8000 Series, and CLAAS Trion 600 and 700 Series Combines ..... 370

3.10.1 Header Settings Quick Reference – CLAAS Lexion 6000, 7000 and 8000 Series, and CLAAS Trion 600  
and 700 Series Combines ..... 370

3.10.2 Setting up Header – CLAAS Lexion 6000, 7000 and 8000 Series, and CLAAS Trion 600 and 700 Series  
Combines ..... 370

3.10.3 Calibrating Auto Header Height Control – CLAAS Lexion 6000, 7000 and 8000 Series, and CLAAS Trion  
600 and 700 Series Combines ..... 372

3.10.4 Setting Cut and Reel Height Preset – CLAAS Lexion 6000, 7000 and 8000 Series, and CLAAS Trion 600  
and 700 Series Combines ..... 375

3.10.5 Setting Auto Header Height Control Sensitivity – CLAAS Lexion 6000, 7000 and 8000 Series, and CLAAS  
Trion 600 and 700 Series Combines ..... 376

3.10.6 Adjusting Auto Reel Speed – CLAAS Lexion 6000, 7000 and 8000 Series, and CLAAS Trion 600 and  
700 Series Combines ..... 378

3.10.7 Calibrating Reel Height Sensor and Reel Fore-Aft Sensor – CLAAS Lexion 6000, 7000 and 8000 Series,  
and CLAAS Trion 600 and 700 Series Combines ..... 379

3.11 Gleaner® R65, R66, R75, R76, and Pre-2016 S Series Combines ..... 383

3.11.1 Checking Voltage Range from Combine Cab – Gleaner® R65, R66, R75, R76, and Pre-2016  
S Series ..... 383

3.11.2 Engaging Auto Header Height Control – Gleaner® R65, R66, R75, R76, and Pre-2016 S Series ..... 385

3.11.3 Calibrating Auto Header Height Control – Gleaner® R65, R66, R75, R76, and Pre-2016 S Series ..... 386

3.11.4 Turning off Accumulator – Gleaner® R65, R66, R75, R76, and Pre-2016 S Series ..... 390

3.11.5 Adjusting Header Raise/Lower Rate – Gleaner® R65, R66, R75, R76, and Pre-2016 S Series ..... 391

3.11.6 Adjusting Ground Pressure – Gleaner® R65, R66, R75, R76, and Pre-2016 S Series ..... 391

3.11.7 Adjusting Auto Header Height Control Sensitivity – Gleaner® R65, R66, R75, R76, and Pre-2016  
S Series ..... 392

3.11.8 Troubleshooting Alarms and Diagnostic Faults – Gleaner® R65, R66, R75, R76, and Pre-2016  
S Series ..... 393

3.12 Gleaner® S9 Series Combines ..... 396

3.12.1 Setting up Header – Gleaner® S9 Series ..... 396

3.12.2 Setting Minimum Reel Speed and Calibrating Reel – Gleaner® S9 Series ..... 401

3.12.3 Setting up Automatic Header Controls – Gleaner® S9 Series ..... 403

## TABLE OF CONTENTS

---

3.12.4	Calibrating Auto Header Height Control – Gleaner® S9 Series .....	405
3.12.5	Operating Auto Header Height Control – Gleaner® S9 Series .....	410
3.12.6	Reviewing Header In-Field Settings – Gleaner® S9 Series.....	412
3.12.7	Header Settings Quick Reference – Gleaner® S9 Series .....	413
3.13	IDEAL™ Series Combines.....	415
3.13.1	Header Settings Quick Reference – IDEAL™ Series.....	415
3.13.2	Setting up Header – IDEAL™ Series.....	415
3.13.3	Setting Minimum Reel Speed and Calibrating Reel – IDEAL™ Series.....	420
3.13.4	Setting up Automatic Header Controls – IDEAL™ Series.....	422
3.13.5	Calibrating Header – IDEAL™ Series .....	423
3.13.6	Operating Header – IDEAL™ Series .....	427
3.13.7	Reviewing Header In-Field Settings – IDEAL™ Series .....	429
3.14	John Deere 60 Series Combines.....	431
3.14.1	Checking Voltage Range from Combine Cab – John Deere 60 Series .....	431
3.14.2	Calibrating Auto Header Height Control – John Deere 60 Series.....	433
3.14.3	Turning Accumulator Off – John Deere 60 Series.....	436
3.14.4	Setting Header Height Sensitivity – John Deere 60 Series.....	437
3.14.5	Setting Auto Header Height Control Sensitivity – John Deere 60 Series .....	437
3.14.6	Adjusting Drop Rate Valve Threshold – John Deere 60 Series .....	438
3.15	John Deere 70 Series Combines.....	440
3.15.1	Checking Voltage Range from Combine Cab – John Deere 70 Series .....	440
3.15.2	Calibrating Feeder House Speed – John Deere 70 Series.....	443
3.15.3	Adjusting Manual Header Raise/Lower Rate – John Deere 70 Series .....	443
3.15.4	Calibrating Auto Header Height Control – John Deere 70 Series.....	444
3.15.5	Setting Auto Header Height Control Sensitivity – John Deere 70 Series .....	447
3.16	John Deere S and T Series Combines .....	448
3.16.1	Checking Voltage Range from Combine Cab – John Deere S and T Series.....	448
3.16.2	Adjusting Manual Header Raise/Lower Rate – John Deere S and T Series .....	451
3.16.3	Calibrating Auto Header Height Control – John Deere S and T Series .....	452
3.16.4	Setting Auto Header Height Control Sensitivity – John Deere S and T Series.....	456
3.16.5	Setting Preset Cutting Height – John Deere S and T Series .....	457
3.16.6	Calibrating Feeder House Fore-Aft Tilt Range – John Deere S and T Series, Model Year 2015 and Later.....	460
3.16.7	Checking Reel Height Sensor Voltages – John Deere S and T Series .....	463
3.16.8	Calibrating Reel Height Sensor and Reel Fore-Aft Sensor – John Deere S and T Series.....	466
3.17	John Deere S7 Series Combines .....	469
3.17.1	Setting up Header – John Deere S7 Series.....	469
3.17.2	Checking Voltage Range from Combine Cab – John Deere S7 Series .....	472
3.17.3	Calibrating Feeder House – John Deere S7 Series .....	475
3.17.4	Calibrating Header – John Deere S7 Series .....	478
3.18	John Deere X9 Series Combines.....	483
3.18.1	Setting up Header in CommandCenter™ Display – John Deere X9 Series .....	483
3.18.2	Calibrating Auto Header Height Control – John Deere X9 Series.....	485

## TABLE OF CONTENTS

3.18.3	Checking Voltage Range from Combine Cab – John Deere X9 Series .....	488
3.18.4	Using Auto Header Height Control – John Deere X9 Series.....	491
3.18.5	Checking Error Codes on Header Controller – John Deere X9 Series.....	497
3.18.6	Reel Reverse Function – John Deere X9 Series .....	499
3.19	New Holland CR and CX Series Combines – 2014 and Earlier.....	500
3.19.1	Checking Voltage Range from Combine Cab – New Holland CR and CX Series.....	500
3.19.2	Header Settings Quick Reference – New Holland CR Series .....	503
3.19.3	Setting up Auto Header Height Control – New Holland CR and CX Series .....	503
3.19.4	Calibrating Auto Header Height Control – New Holland CR and CX Series .....	504
3.19.5	Calibrating Maximum Stubble Height – New Holland CR and CX Series .....	507
3.19.6	Adjusting Header Raise Rate – New Holland CR and CX Series .....	508
3.19.7	Adjusting Header Lower Rate – New Holland CR and CX Series .....	509
3.19.8	Setting Auto Header Height Control Sensitivity – New Holland CR and CX Series.....	510
3.19.9	Setting Preset Cutting Height – New Holland CR and CX Series .....	510
3.20	New Holland Combines – CR Series (2015 and Later) and CH .....	513
3.20.1	Checking Voltage Range from Combine Cab – New Holland CR Series and CH .....	513
3.20.2	Setting up Auto Header Height Control – New Holland CR Series and CH.....	516
3.20.3	Setting up Reel Speed – New Holland CR Series and CH .....	519
3.20.4	Calibrating Auto Header Height Control – New Holland CR Series and CH.....	520
3.20.5	Calibrating Reel Height Sensor and Reel Fore-Aft Sensor – New Holland CR Series and CH .....	524
3.20.6	Checking Reel Height Sensor Voltages – New Holland CR Series and CH .....	527
3.20.7	Setting Preset Cutting Height – New Holland CR Series and CH.....	528
3.20.8	Setting Maximum Work Height – New Holland CR Series and CH .....	530
3.20.9	Configuring Reel Fore-Aft, Header Tilt, and Header Type – New Holland CR Series and CH .....	531
3.20.10	Reel Reverse Function – New Holland CR Series and CH .....	533
3.21	Rostselmash Combines – RSM 161, T500, and TORUM 785.....	536
3.21.1	Calibrating Auto Header Height Control – Rostselmash RSM 161, T500, and TORUM 785 .....	536
3.21.2	Engaging Auto Header Height Control – Rostselmash RSM 161, T500, and TORUM 785 .....	538
3.21.3	Calibrating Reel Speed – Rostselmash RSM 161, T500, and TORUM 785 .....	539
3.21.4	Operating Header – Rostselmash RSM 161, T500, and TORUM 785 .....	541
3.10	Unplugging Cutterbar .....	543
3.11	Unplugging Float Module Feed Draper .....	544
3.12	Transport .....	545
3.12.1	Transporting Header on Combine.....	545
3.12.2	Towing .....	545
	Attaching Header to Towing Vehicle .....	546
	Precautions for Towing Header .....	546
3.12.3	Converting from Transport to Field Position (Option).....	547
	Moving Left Outboard Wheel From Transport to Working Position – ContourMax™ Option.....	547
	Removing Tow-Bar.....	548
	Storing Tow-Bar.....	551
	Moving Front (Left) Wheels into Field Position.....	552
	Moving Rear (Right) Wheels into Field Position .....	555
3.12.4	Converting from Field to Transport Position (Option).....	557
	Moving Left Outboard Wheel From Working to Transport Position.....	557

## TABLE OF CONTENTS

---

Moving Front (Left) Wheels into Transport Position .....	558
Moving Rear (Right) Wheels into Transport Position .....	559
Removing Tow-Bar from Storage .....	561
Attaching Tow-Bar .....	562
<b>Chapter 4: Maintenance and Servicing.....</b>	<b>567</b>
<b>4.1 Preparing Machine for Servicing.....</b>	<b>567</b>
<b>4.2 Maintenance Requirements .....</b>	<b>568</b>
4.2.1 Maintenance Schedule/Record .....	568
4.2.2 Break-in Inspection .....	570
4.2.3 Equipment Servicing – Preseason.....	571
4.2.4 Equipment Servicing – End-of-Season .....	571
4.2.5 Checking Hydraulic Hoses and Lines .....	572
<b>4.3 Lubrication .....</b>	<b>574</b>
4.3.1 Lubrication Intervals .....	574
Every 10 Hours.....	574
Every 25 Hours.....	575
Every 50 Hours.....	576
Every 100 Hours .....	580
Every 250 Hours .....	582
Every 500 Hours .....	584
4.3.2 Greasing Procedure .....	585
4.3.3 Lubricating Reel Drive Chain .....	587
4.3.4 Lubricating Auger Drive Chain .....	587
4.3.5 Lubricating Header Drive Main Gearbox.....	589
Checking Oil Level in Header Drive Main Gearbox.....	589
Adding Oil to Header Drive Main Gearbox.....	590
Changing Oil in Header Drive Main Gearbox .....	590
4.3.6 Lubricating Header Drive Completion Gearbox .....	591
Checking Oil Level in Header Drive Completion Gearbox.....	591
Adding Oil to Header Drive Completion Gearbox.....	592
Changing Oil in Header Drive Completion Gearbox .....	593
<b>4.4 Hydraulics .....</b>	<b>595</b>
4.4.1 Checking Oil Level in Hydraulic Reservoir .....	595
4.4.2 Adding Oil to Hydraulic Reservoir.....	595
4.4.3 Changing Oil in Hydraulic Reservoir .....	596
4.4.4 Changing Oil Filter.....	597
<b>4.5 Electrical System .....</b>	<b>599</b>
4.5.1 Replacing Light Bulbs .....	599
<b>4.6 Header Drive .....</b>	<b>600</b>
4.6.1 Removing Driveline .....	600
4.6.2 Installing Driveline.....	602
4.6.3 Removing Driveline Guard .....	605
4.6.4 Installing Driveline Guard .....	607
4.6.5 Adjusting Chain Tension – Main Gearbox .....	609
4.6.6 Adjusting Chain Tension – Completion Gearbox.....	610

## TABLE OF CONTENTS

<b>4.7</b>	<b>Feed Auger</b> .....	612
4.7.1	Adjusting Feed-Auger-to-Pan Clearance .....	612
4.7.2	Checking Feed Auger Chain Tension .....	614
	Checking Feed Auger Drive Chain Tension – Quick Method .....	614
	Checking Feed Auger Drive Chain Tension – Thorough Method.....	616
4.7.3	Adjusting Feed Auger Drive Chain Tension.....	618
4.7.4	Auger Flighting .....	620
4.7.5	Auger Fingers .....	621
	Removing Feed Auger Fingers .....	621
	Installing Feed Auger Fingers .....	623
	Checking Auger Finger Timing .....	625
	Adjusting Auger Finger Timing .....	626
<b>4.8</b>	<b>Knife</b> .....	629
4.8.1	Replacing Knife Section .....	629
4.8.2	Removing Knife .....	630
4.8.3	Installing Knife.....	631
4.8.4	Spare Knives .....	633
4.8.5	Pointed Knife Guards and Hold-Downs.....	634
	Pointed Knife Guard Configuration on Single-Knife Headers .....	635
	Pointed Knife Guard Configuration on Double-Knife Header – FD235 .....	636
	Pointed Knife Guard Configuration on Double-Knife Header – FD240 .....	637
	Pointed Knife Guard Configuration on Double-Knife Header – FD241 .....	638
	Pointed Knife Guard Configuration on Double-Knife Header – FD245 .....	639
	Pointed Knife Guards Configuration on Double-Knife Header – FD250.....	640
	Adjusting Knife Guards and Guard Bar .....	641
	Replacing Pointed Knife Guards.....	643
	Checking Hold-Down – Pointed Knife Guards .....	645
	Adjusting Hold-Down – Pointed Knife Guards .....	646
	Replacing Pointed Center Knife Guard – Double-Knife Header .....	647
	Checking Center Hold-Down on Double-Knife Header – Pointed Knife Guards .....	650
	Adjusting Center Hold-Down on Double-Knife Header – Pointed Knife Guards.....	651
4.8.6	Short Knife Guards and Hold-Downs.....	652
	Short Knife Guard Configuration on Single-Knife Headers.....	653
	Short Knife Guard Configuration on Double-Knife Headers – All Sizes Except D241 .....	654
	Short Knife Guard Configuration on Double-Knife Headers – FD241 .....	655
	Replacing Short Knife Guards or End Knife Guards .....	656
	Checking Hold-Down – Short Knife Guards .....	658
	Adjusting Hold-Down – Short Knife Guards.....	659
	Replacing Center Knife Guard – Double-Knife Headers .....	660
	Checking Center Hold-Down on Double-Knife Headers – Short Knife Guards .....	662
	Adjusting Center Hold-Down – Short Knife Guards.....	663
4.8.7	Knifehead Shield .....	664
	Installing Knifehead Shield.....	664
<b>4.9</b>	<b>Knife Drive System</b> .....	666
4.9.1	Knife Drive Box .....	666
	Checking Oil Level in Knife Drive Box.....	666
	Checking Mounting Bolts .....	667
	Changing Oil in Knife Drive Box .....	667
<b>4.10</b>	<b>Feed Deck</b> .....	669
4.10.1	Replacing Feed Draper .....	669



## TABLE OF CONTENTS

---

4.10.2	Checking and Adjusting Feed Draper Tension .....	674
4.10.3	Feed Draper Drive Roller .....	676
	Removing Feed Draper Drive Roller .....	676
	Installing Feed Draper Drive Roller.....	678
	Removing Feed Draper Drive Roller Bearing .....	679
	Installing Feed Draper Drive Roller Bearing.....	682
4.10.4	Feed Draper Idler Roller .....	682
	Removing Feed Draper Idler Roller .....	682
	Installing Feed Draper Idler Roller.....	685
	Replacing Feed Draper Idler Roller Bearing.....	688
4.10.5	Lowering Feed Deck Pan.....	691
4.10.6	Raising Feed Deck Pan.....	693
4.10.7	Checking Link Holder Hooks .....	694
<b>4.11</b>	<b>Stripper Bars .....</b>	<b>696</b>
	4.11.1 Removing Stripper Bars .....	696
	4.11.2 Installing Stripper Bars .....	696
<b>4.12</b>	<b>Header Side Drapers.....</b>	<b>698</b>
	4.12.1 Removing Side Drapers .....	698
	4.12.2 Installing Side Drapers.....	700
	4.12.3 Adjusting Side Draper Deck Height .....	701
	4.12.4 Adjusting Side Draper Tension .....	703
	4.12.5 Adjusting Side Draper Tracking .....	706
	4.12.6 Inspecting Draper Roller Bearing.....	707
	4.12.7 Removing Side Draper Deck Idler Roller.....	707
	4.12.8 Replacing Side Draper Deck Idler Roller Bearing.....	709
	4.12.9 Installing Side Draper Deck Idler Roller.....	712
	4.12.10 Removing Side Draper Drive Roller .....	714
	4.12.11 Replacing Side Draper Drive Roller Bearing.....	716
	4.12.12 Installing Side Draper Drive Roller.....	717
<b>4.13</b>	<b>Reel.....</b>	<b>720</b>
	4.13.1 Reel-to-Cutterbar Clearance .....	720
	Measuring Reel-to-Cutterbar Clearance .....	720
	Adjusting Reel-to-Cutterbar Clearance.....	724
	4.13.2 Reel Frown.....	727
	Adjusting Reel Shape.....	727
	4.13.3 Centering Reel .....	727
	4.13.4 Reel Fingers.....	729
	Removing Steel Reel Fingers .....	729
	Installing Steel Reel Fingers .....	730
	Removing Plastic Reel Fingers .....	730
	Installing Plastic Reel Fingers .....	731
	4.13.5 Tine Tube Bushings.....	732
	Removing Bushings from Reels.....	732
	Installing Bushings onto Reels .....	735
	4.13.6 Reel Endshields.....	738
	Replacing Reel Endshields at Outboard Cam End.....	739
	Replacing Reel Endshields at Inboard Cam End .....	741



## TABLE OF CONTENTS

Replacing Reel Endshields at Outboard Tail End .....	743
Replacing Reel Endshields at Inboard Tail End.....	744
Replacing Reel Endshield Supports.....	747
<b>4.14 Reel Drive.....</b>	<b>749</b>
4.14.1 Reel Drive Chain.....	749
Loosening Reel Drive Chain .....	749
Tightening Reel Drive Chain .....	750
4.14.2 Reel Drive Sprocket .....	752
Removing Reel Drive Single Sprocket.....	752
Installing Reel Drive Single Sprocket.....	753
Removing Reel Drive Optional Dual Sprocket.....	753
Installing Reel Drive Optional Dual Sprocket .....	755
4.14.3 Changing Reel Speed Chain Position with Two Speed Kit Installed .....	757
4.14.4 Reel Speed Sensor .....	758
Replacing Challenger®, Gleaner®, IDEAL™, or Massey Ferguson® Reel Speed Sensor .....	758
Replacing CLAAS Reel Speed Sensor .....	759
Replacing John Deere Reel Speed Sensor .....	760
<b>4.15 Contour Wheels – Option.....</b>	<b>761</b>
4.15.1 Checking Wheel Bolt Torque — ContourMax™ Option.....	761
4.15.2 Leveling Contour Wheel Height.....	762
4.15.3 Lubricating Contour Wheel System.....	764
4.15.4 Checking Contour Wheel End Play.....	766
4.15.5 Zeroing Mechanical Indicator .....	768
<b>4.16 Transport System (Option) .....</b>	<b>770</b>
4.16.1 Checking Wheel Bolt Torque .....	770
4.16.2 Checking Transport Assembly Bolt Torque .....	770
4.16.3 Checking Tire Pressure .....	772
4.16.4 Changing Tow-Bar Hitch Connection from Pintle to Clevis.....	773
4.16.5 Changing Tow-Bar Hitch Connection from Clevis to Pintle.....	775
<b>4.17 VertiBlade™ Vertical Knife (Option).....</b>	<b>778</b>
4.17.1 Replacing Vertical Knife Sections.....	778
4.17.2 Lubricating Vertical Knife .....	781
4.17.3 Converting VertiBlade™ Knife Position .....	782
<b>Chapter 5: Options and Attachments .....</b>	<b>787</b>
<b>5.1 Crop Delivery Kits .....</b>	<b>787</b>
5.1.1 Crop Lifter Kit.....	787
5.1.2 Crop Lifter Storage Rack Kit .....	787
5.1.3 Crop Divider Storage Bracket Kit .....	788
5.1.4 Floating Crop Dividers.....	788
5.1.5 Full Length Upper Cross Auger .....	789
5.1.6 Lodged Crop Reel Finger Kit .....	790
5.1.7 Rice Divider Rod Kit.....	790
5.1.8 Sunflower Attachment Kit.....	791
5.1.9 End Deflector Rods.....	792
5.1.10 VertiBlade™ Vertical Knife Kit.....	793

## TABLE OF CONTENTS

---

<b>5.2</b>	Cutterbar Kits .....	794
5.2.1	Rock Retarder Kit .....	794
5.2.2	Four-Point Knife Guard .....	794
<b>5.3</b>	FM200 Float Module Kits .....	795
5.3.1	10 V Sensor Adapter Kit .....	795
5.3.2	Crop Deflector Kits .....	795
5.3.3	Extended Center Filler.....	796
5.3.4	Feed Auger High-Wear Flighting Extension Kit .....	797
5.3.5	Full Interface Filler Kit .....	797
5.3.6	Hydraulic Reservoir Extension Kit.....	798
5.3.7	Auto Header Height and Tilt Plug Kits .....	798
5.3.8	Stripper Bars Kit.....	799
<b>5.4</b>	Header Kits.....	800
5.4.1	ContourMax™ Contour Wheels Kit.....	800
5.4.2	ContourMax™ Foot Switch Kit .....	801
5.4.3	EasyMove™ Transport System.....	802
5.4.4	Inboard Steel End Finger Kit.....	803
5.4.5	Outboard Steel End Finger Kit .....	803
5.4.6	Plastic Reel Finger Kit.....	804
5.4.7	Steel Reel Finger Kit.....	804
5.4.8	Side Hill Stabilizer Kit .....	805
5.4.9	Stabilizer Wheel Kit .....	805
5.4.10	Steel Skid Shoes Kit.....	806
5.4.11	Stubble Light Kit.....	806
<b>Chapter 6:</b>	<b>Troubleshooting.....</b>	<b>809</b>
6.1	Crop Loss at Cutterbar .....	809
6.2	Cutting Action and Knife Components .....	811
6.3	Reel Delivery .....	814
6.4	Troubleshooting Header and Drapers.....	816
6.5	Cutting Edible Beans .....	818
6.6	CLAAS Multicoupler Error Codes for Troubleshooting.....	821
<b>Chapter 7:</b>	<b>Reference .....</b>	<b>823</b>
7.1	Torque Specifications .....	823
7.1.1	Metric Bolt Specifications .....	823
7.1.2	Metric Bolt Specifications – Cast Aluminum .....	825
7.1.3	O-Ring Boss Hydraulic Fittings – Adjustable .....	826
7.1.4	O-Ring Boss Hydraulic Fittings – Non-Adjustable .....	827
7.1.5	O-Ring Face Seal Hydraulic Fittings.....	828
7.1.6	Tapered Pipe Thread Fittings.....	829
7.2	Conversion Chart.....	831

TABLE OF CONTENTS

---

**Index..... 833**  
**Recommended Fluids and Lubricants..... 845**



# Chapter 1: Safety

Understanding and consistently following these safety procedures will help to ensure the safety of those operating the machine and of bystanders.

## 1.1 Safety Alert Symbols

The safety alert symbol indicates important safety messages in this manual and on safety signs on the machine.

This symbol means:

- **ATTENTION!**
- **BECOME ALERT!**
- **YOUR SAFETY IS INVOLVED!**

Carefully read and follow the safety message accompanying this symbol.

### Why is safety important to you?

- Accidents disable and kill
- Accidents cost
- Accidents can be avoided



Figure 1.1: Safety Symbol

## 1.2 Signal Words

Three signal words, **DANGER**, **WARNING**, and **CAUTION**, are used to alert you to hazardous situations. Two signal words, **IMPORTANT** and **NOTE**, identify non-safety related information.

Signal words are selected using the following guidelines:

### **DANGER**

Indicates an imminently hazardous situation that, if it is not prevented, will result in death or serious injury.

### **WARNING**

Indicates a potentially hazardous situation that, if it is not prevented, could result in death or serious injury. It may also be used to alert you to unsafe practices.

### **CAUTION**

Indicates a potentially hazardous situation that, if it is not prevented, may result in minor or moderate injury. It may also be used to alert you to unsafe practices.

#### **IMPORTANT:**

Indicates a situation that, if not prevented, could result in a malfunction or damage to the machine.

#### **NOTE:**

Provides additional information or advice.

## 1.3 General Safety

Operating, servicing, and assembling machinery presents several safety risks. These risks can be reduced or eliminated by following the relevant safety procedures and wearing the appropriate personal protective equipment.

### CAUTION

The following general farm safety precautions should be part of your operating procedure for all types of machinery.

Wear all protective clothing and personal safety devices that could be necessary for the job at hand. Do **NOT** take chances. You may need the following:

- Hard hat
- Protective footwear with slip-resistant soles
- Protective glasses or goggles
- Heavy gloves
- Wet weather gear
- Respirator or filter mask

In addition, take the following precautions:

- Be aware that exposure to loud noises can cause hearing impairment. Wear suitable hearing protection devices such as earmuffs or earplugs to help protect against loud noises.



Figure 1.2: Safety Equipment



Figure 1.3: Safety Equipment

- Provide a first aid kit in case of emergencies.
- Keep a properly maintained fire extinguisher on the machine. Familiarize yourself with its use.
- Keep young children away from machinery at all times.
- Be aware that accidents often happen when Operators are fatigued or in a hurry. Take time to consider the safest way to accomplish a task. **NEVER** ignore the signs of fatigue.

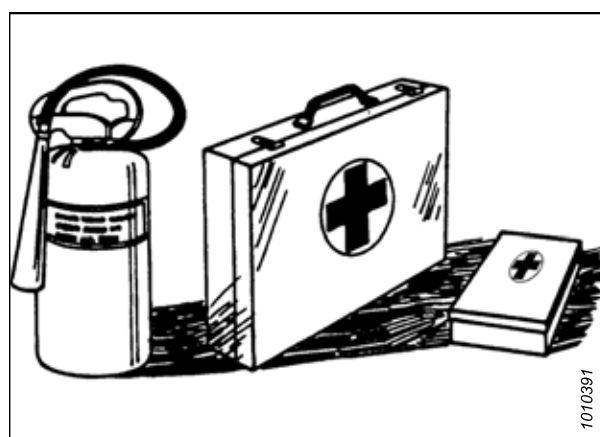


Figure 1.4: Safety Equipment

## SAFETY

- Wear close-fitting clothing and cover long hair. **NEVER** wear dangling items such as hoodies, scarves, or bracelets.
- Keep all shields in place. **NEVER** alter or remove safety equipment. Ensure that the driveline guards can rotate independently of their shaft, and that they can telescope freely.
- Use only service and repair parts made or approved by the equipment manufacturer. Parts from other manufacturers may not meet the correct strength, design, or safety requirements.



Figure 1.5: Safety around Equipment

- Keep hands, feet, clothing, and hair away from moving parts. **NEVER** attempt to clear obstructions or objects from a machine while the engine is running.
- Do **NOT** modify the machine. Unauthorized modifications may impair the functionality and/or safety of the machine. It may also shorten the machine's service life.
- To avoid injury or death from the unexpected startup of the machine, **ALWAYS** stop the engine and remove the key from the ignition before leaving the operator's seat for any reason.

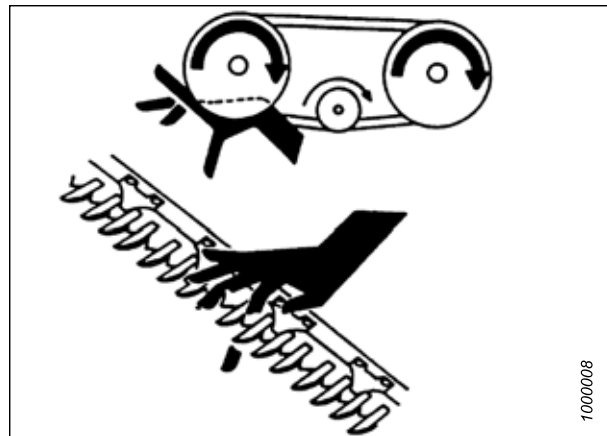


Figure 1.6: Safety around Equipment

- Keep the machine service area clean and dry. Wet and/or oily floors are slippery. Wet spots can be dangerous when working with electrical equipment. Ensure that all electrical outlets and tools are properly grounded.
- Keep the work area well-lit.
- Keep machinery clean. Straw and chaff on a hot engine are fire hazards. Do **NOT** allow oil or grease to accumulate on service platforms, ladders, or controls. Clean machines before they are stored.
- **NEVER** use gasoline, naphtha, or any volatile material for cleaning purposes. These materials may be toxic and/or flammable.
- When storing machinery, cover any sharp or extending components to prevent injury from accidental contact.



Figure 1.7: Safety around Equipment



## 1.4 Maintenance Safety

Maintaining your equipment safely requires that you follow the relevant safety procedures and wear the appropriate personal protective equipment for the task.

To ensure your safety while maintaining the machine:

- Review the operator's manual and all safety items before operating or performing maintenance on the machine.
- Place all controls in Neutral, stop the engine, set the parking brake, remove the ignition key, and wait for all moving parts to stop before servicing, adjusting, or repairing the machine.
- Follow good shop practices:
  - Keep service areas clean and dry
  - Ensure that electrical outlets and tools are properly grounded
  - Keep the work area well lit
- Relieve pressure from hydraulic circuits before servicing and/or disconnecting the machine.
- Ensure that all components are tight and that steel lines, hoses, and couplings are in good condition before applying pressure to hydraulic systems.
- Keep hands, feet, clothing, and hair away from all moving and/or rotating parts.
- Clear the area of bystanders, especially children, when carrying out any maintenance, repairs, or adjustments.
- Install the transport lock or place safety stands under the frame before working under the machine.
- If more than one person is servicing the machine at the same time, be aware that rotating a driveline or another mechanically driven component by hand (for example, accessing a lubricant fitting) will cause drive components in other areas (belts, pulleys, and knives) to move. Stay clear of driven components at all times.



Figure 1.8: Wet Floors Present Safety Risks

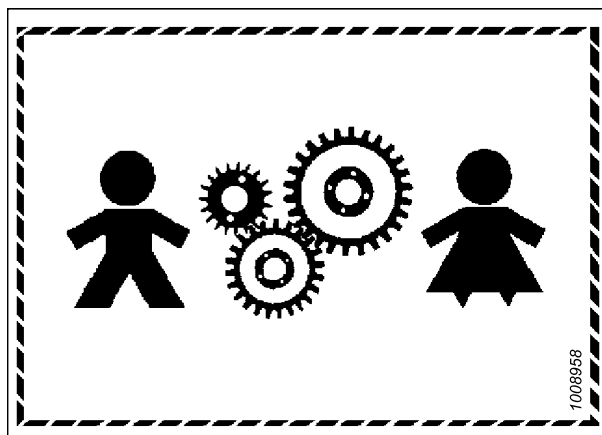


Figure 1.9: Equipment is NOT Safe for Children

## SAFETY

- Wear protective gear when working on the machine.
- Wear heavy gloves when working on knife components.



Figure 1.10: Personal Protective Equipment

## 1.5 Hydraulic Safety

Because hydraulic fluid is under extreme pressure, hydraulic fluid leaks can be very dangerous. Follow the proper safety procedures when inspecting hydraulic fluid leaks and servicing hydraulic equipment.

- Always place all hydraulic controls in **NEUTRAL** before leaving the operator's seat.
- Ensure that all of the components in the hydraulic system are kept clean and in good condition.
- Replace any worn, cut, abraded, flattened, or crimped hoses and steel lines.
- Do **NOT** attempt any makeshift repairs to hydraulic lines, fittings, or hoses by using tapes, clamps, cements, or welding. The hydraulic system operates under extremely high pressure. Makeshift repairs can fail suddenly and create hazardous conditions.

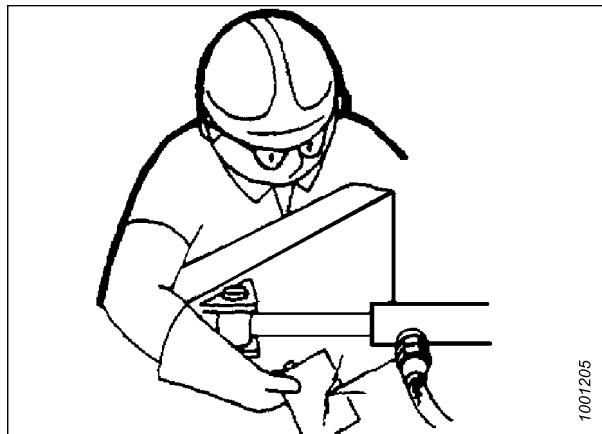


Figure 1.11: Testing for Hydraulic Leaks

- Wear proper hand and eye protection when searching for high-pressure hydraulic fluid leaks. Use a piece of cardboard as a backstop instead of your hands to isolate and identify a leak.
- If you are injured by a concentrated, high-pressure stream of hydraulic fluid, seek medical attention immediately. Serious infection or a toxic reaction can develop from hydraulic fluid piercing the skin.



Figure 1.12: Hydraulic Pressure Hazard

- Ensure that all components are tight and that steel lines, hoses, and couplings are in good condition before applying pressure to a hydraulic system.

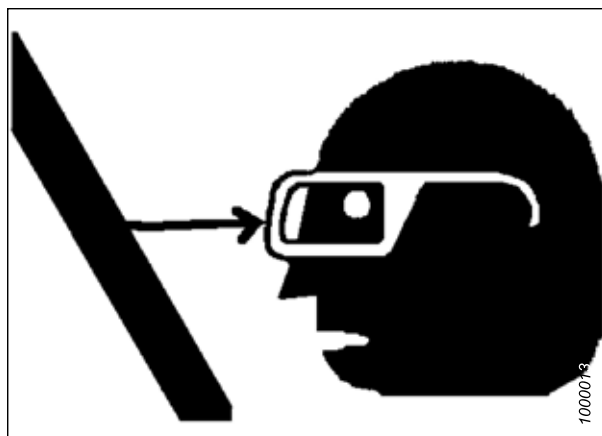


Figure 1.13: Safety around Equipment

## 1.6 Welding Precautions

To prevent damage to sensitive electronics, **NEVER** attempt welding on the header while it is connected to a combine.

### WARNING

**NEVER** attempt welding on the header while it is connected to a combine. Severe damage to sensitive, expensive electronics can result from welding on the header while it is connected to a combine. It can be impossible to know what effect a high current may have regarding future malfunctions or a shorter lifespan.

For further welding precautions, consult the combine operator's manual.

Before welding on a header, you **MUST** detach the header from the combine, and then disconnect the following electrical components from the header:

#### Draper Speed Control Module

1. On the FM200 adapter, between the frame and the header, disconnect draper speed control module (A) from solenoid (B).

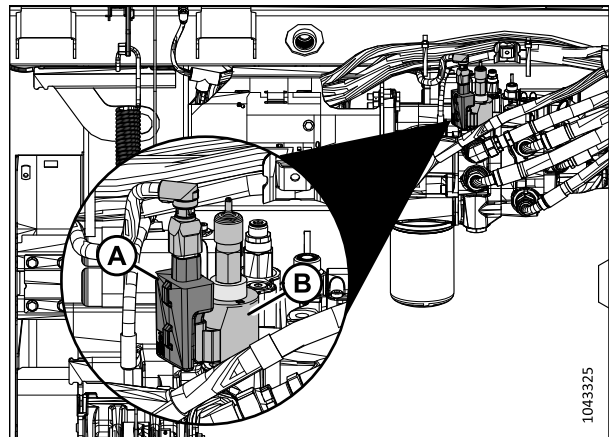


Figure 1.14: Draper Speed Control Module

#### John Deere X9 Integration Module

2. On the FM200 frame, between the header and the adapter, disconnect John Deere X9 integration module (A) by unplugging bulkhead (B) from the module.

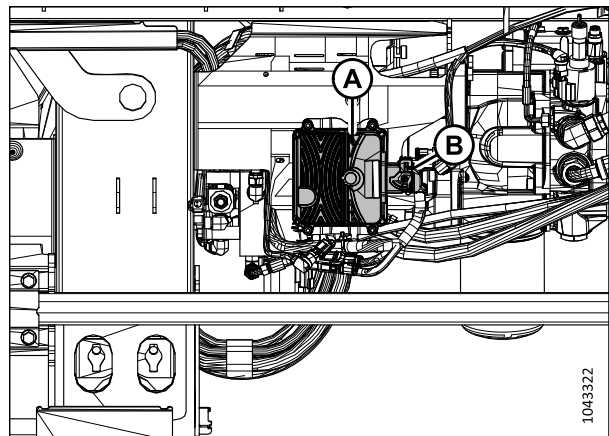


Figure 1.15: John Deere X9 Integration Module

## SAFETY

3. To unplug the bulkhead from the module, push in tab (A) to unlatch arm (B).
4. Push arm (B) downward until it is in the position shown. Unplug the bulkhead from the module.

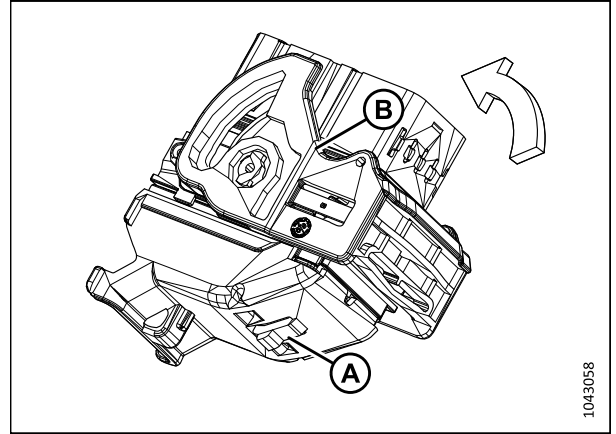


Figure 1.16: Unplugging Bulkhead from Control Module

## CLAAS Integration Module

5. On the FM200 frame, between the header and the adapter, disconnect CLAAS integration module (A) by unplugging connector (B).

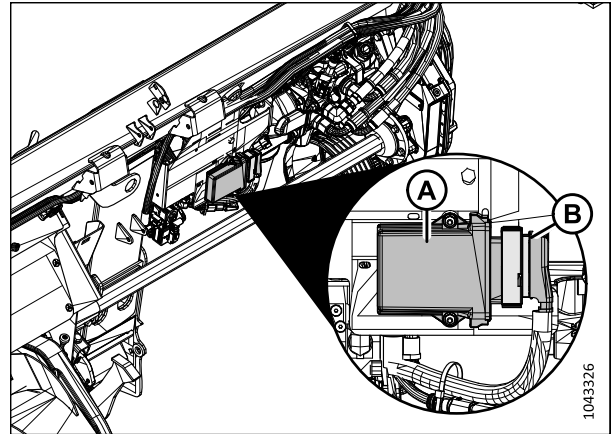


Figure 1.17: CLAAS Integration Module

6. To unplug the connector, use a screwdriver or a pair of needle nose pliers to slowly pull out latch (A) while allowing the connector to back off of the integration module.

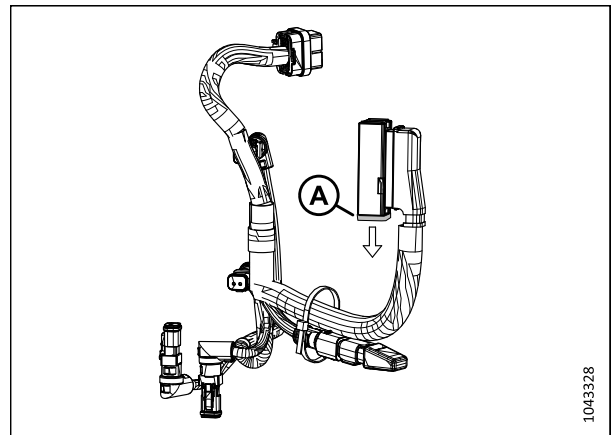


Figure 1.18: CLAAS Integration Harness

## 1.7 Decommissioning and Disposing of Agricultural Equipment

When agricultural equipment is no longer serviceable and needs to be decommissioned and disposed of, recyclable materials including ferrous and non-ferrous metals, rubber, and plastics; fluids such as lubricants, refrigerants, and fuels; and hazardous materials found in batteries, some light bulbs, and electronic equipment must be handled safely and not introduced into the environment.

Comply with local regulations and authorities.

Products with symbol (A) should **NOT** be disposed of with domestic waste.

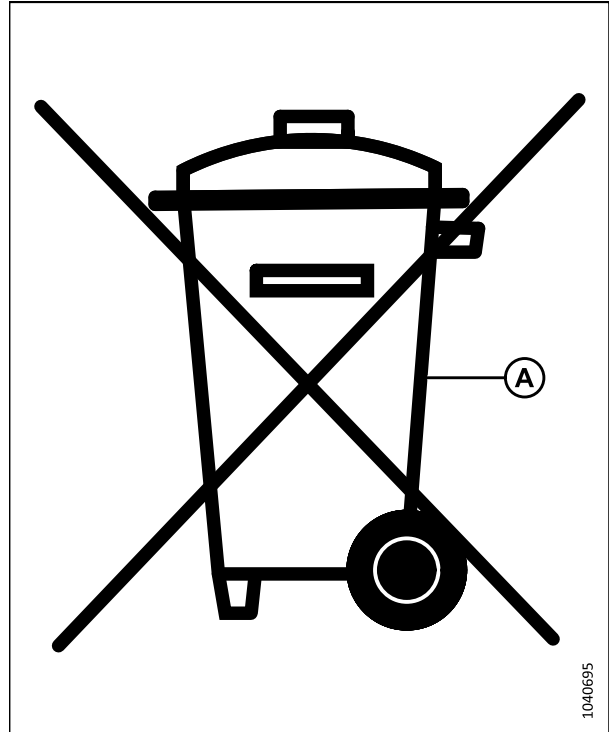


Figure 1.19: Symbol for Do NOT Dispose with Domestic Waste

Materials with symbol (B) should be recycled as labelled.

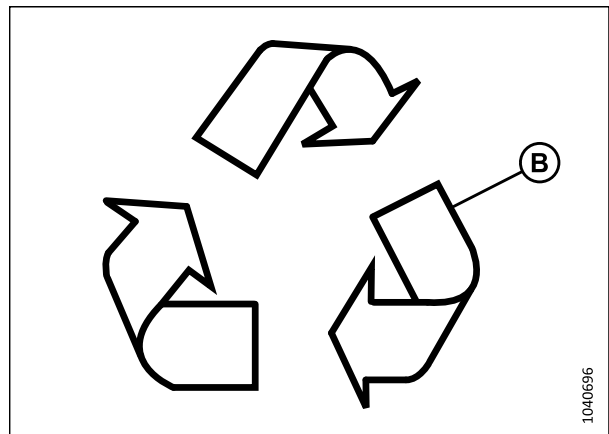


Figure 1.20: Symbol for Recycle as Labelled

## SAFETY

- Use appropriate personal protective equipment when removing and handling objects and materials.
- Use appropriate personal protective equipment when handling objects with residue from pesticides, fertilizers, or other agricultural chemicals. Follow local regulations when handling and disposing of these objects.
- Safely release stored energy from suspension components, springs, hydraulic, and electrical systems.
- Recycle or reuse packaging material.
- Recycle or reuse plastics that are labelled with specifications for a material such as PP TV 20. Do **NOT** dispose of them with domestic waste.
- Return batteries to the vendor or take them to a collection point. Batteries contain hazardous substances. Do **NOT** dispose of batteries with domestic waste.
- Follow local regulations to correctly dispose of hazardous materials such as oils, hydraulic fluids, brake fluids, and fuels.
- Take refrigerants to qualified people at specialized facilities for disposal. Refrigerants must **NEVER** be released into the atmosphere.

## 1.8 Safety Signs

Safety signs are decals placed on the machine where there is a risk of personal injury, or where the Operator should take extra precautions before operating the controls. They are usually yellow.

- Keep safety signs clean and legible at all times.
- Replace safety signs that are missing or illegible.
- If the original part on which a safety sign was installed is replaced, ensure that the repair part displays the current safety sign.
- Replacement safety signs are available from your Dealer.

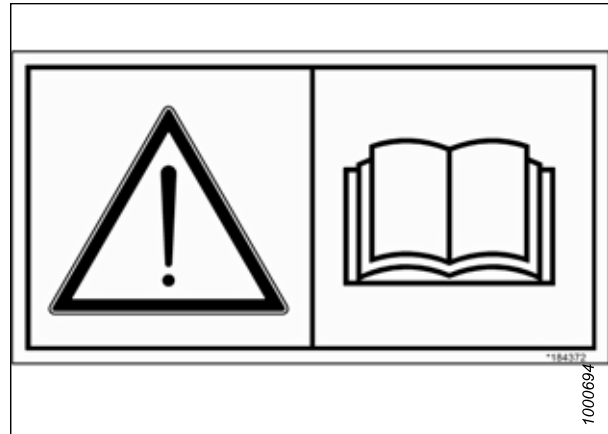


Figure 1.21: Operator's Manual Decal

### 1.8.1 Installing Safety Decals

Worn or damaged safety decals will need to be removed and replaced.

1. Decide exactly where you are going to place the decal.
2. Clean and dry the installation area.
3. Remove the smaller portion of the split backing paper.
4. Place the decal in position and slowly peel back the remaining paper, smoothing the decal as it is applied.
5. Prick small air pockets with a pin and smooth them out.



## 1.9 Safety Decal Locations

Safety signs are usually yellow decals and are placed on the machine where there is a risk of injury or where the Operator should take extra precautions before working.

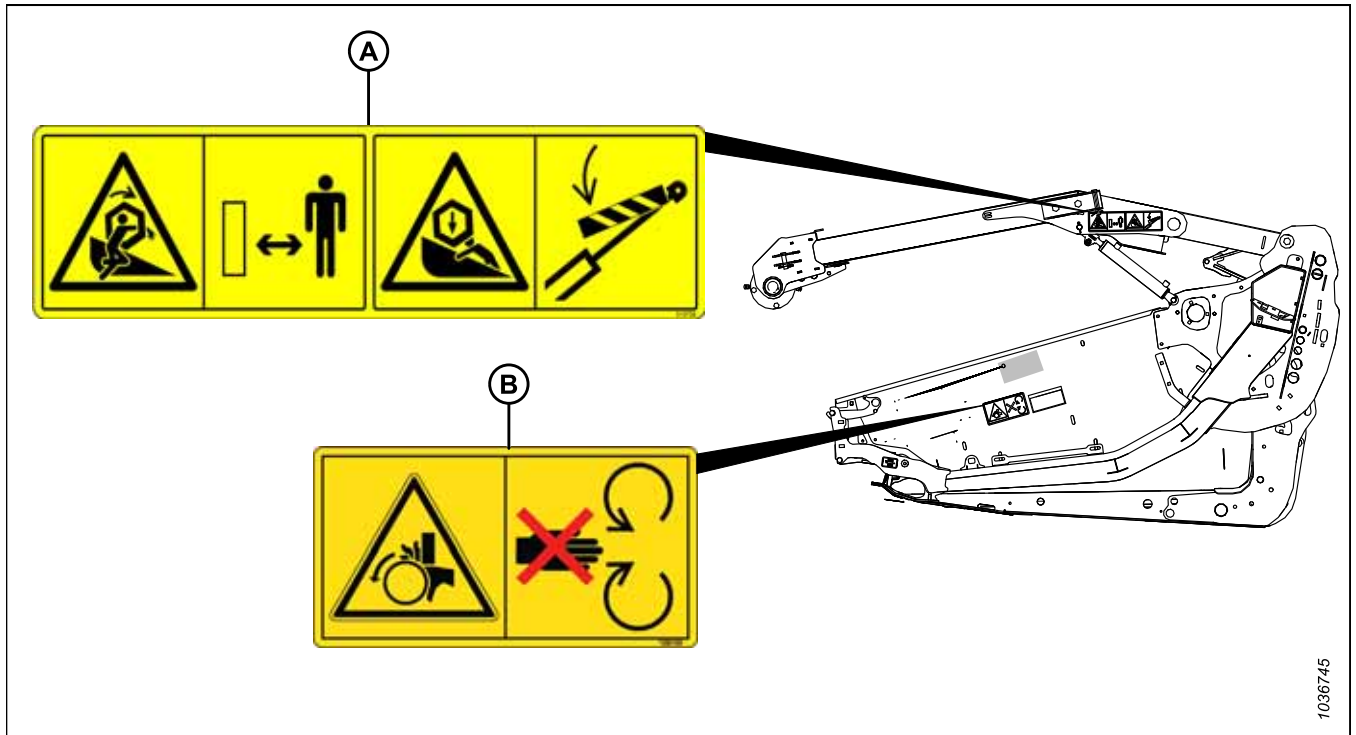


Figure 1.22: Reel Arms and Endsheets

A - MD #360541 – Reel Entanglement / Reel Crushing Hazard (Two Locations)

B - MD #288195 – Danger, Rotating Part (Two Locations)

1036745

SAFETY

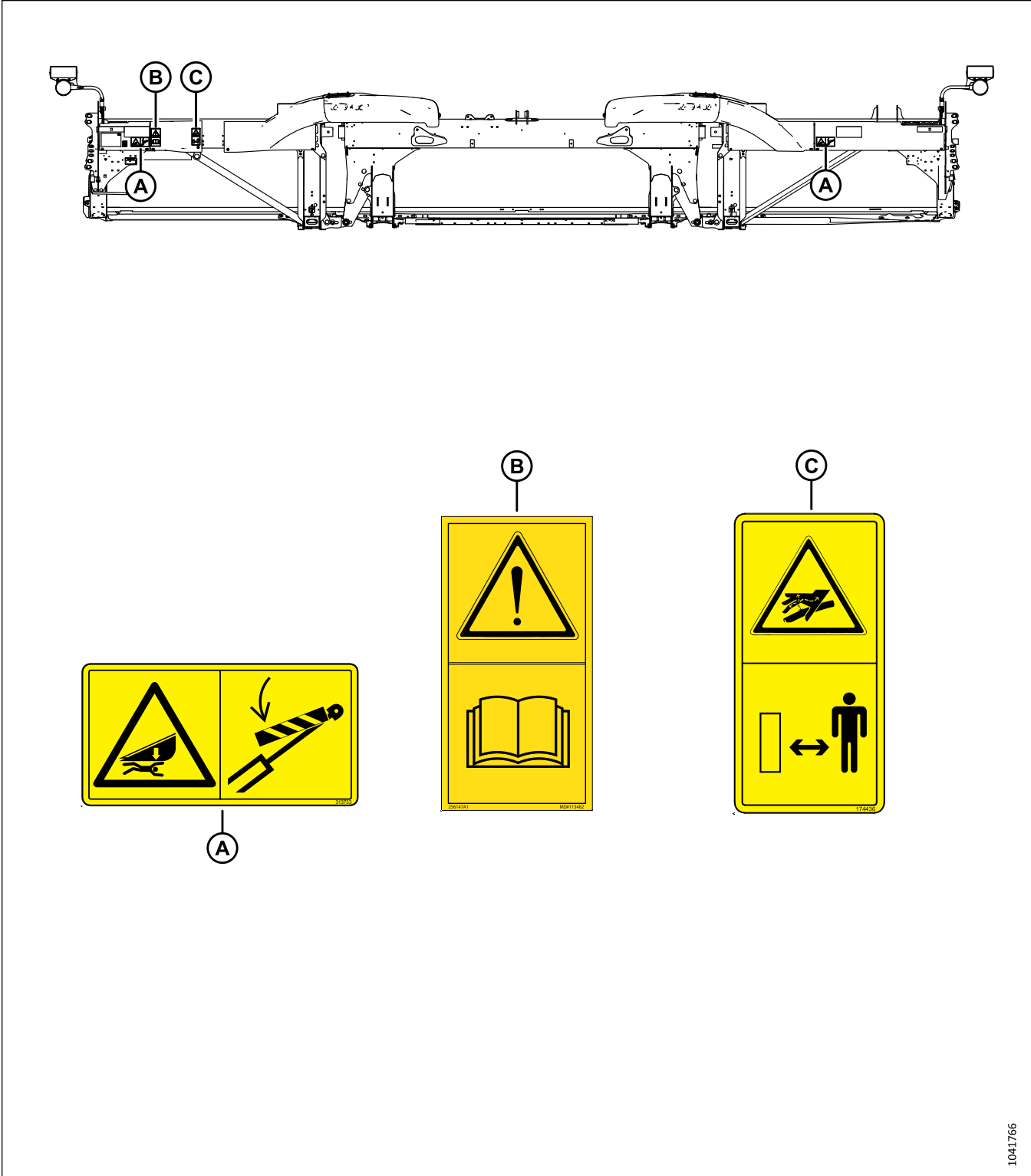


Figure 1.23: Backtube, FD225

A - MD #313733 – Header Crushing Hazard

B - MD #113482 – General Hazard

C - MD #174436 – High Pressure Fluid

1041766

SAFETY

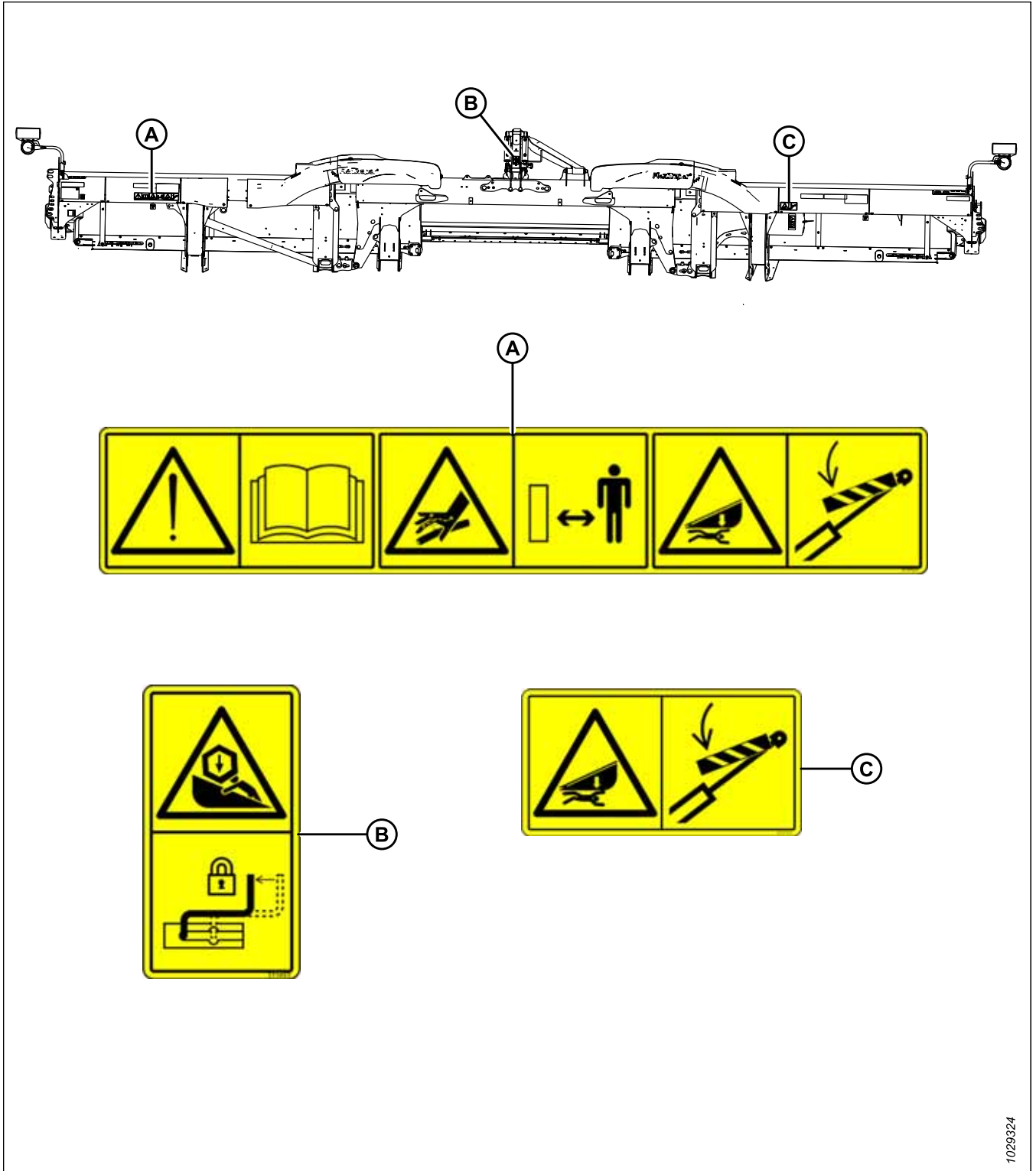


Figure 1.24: Backtube, FD230 and Larger

A - MD #313725 – Read Manual / High Pressure Fluid / Header Hazard  
C - MD #313733 – Header Crushing Hazard

B - MD #311493 – Center Prop Lock

1029324

SAFETY

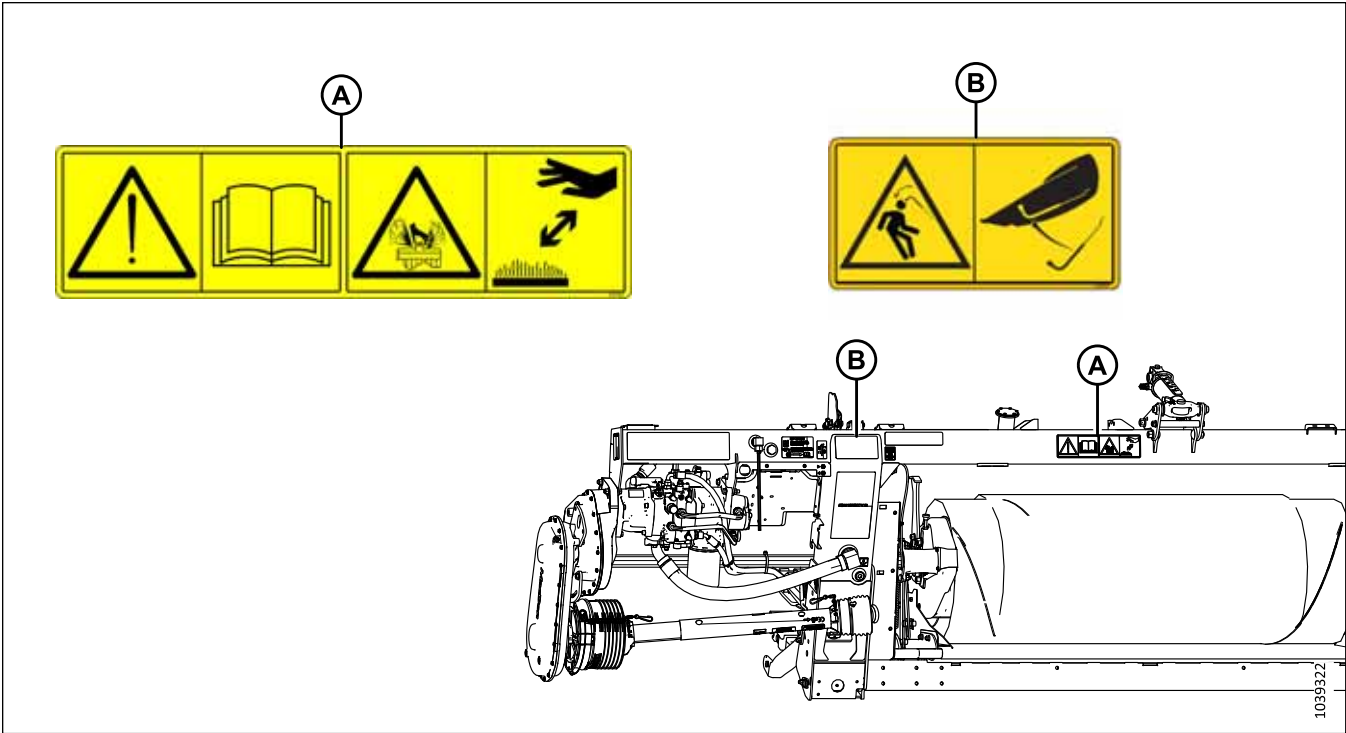


Figure 1.25: FM200 Float Module

A - MD #313728 – Read Manual / Fluid Spray Hazard

B - MD #360655 – Released Spring Energy Hazard

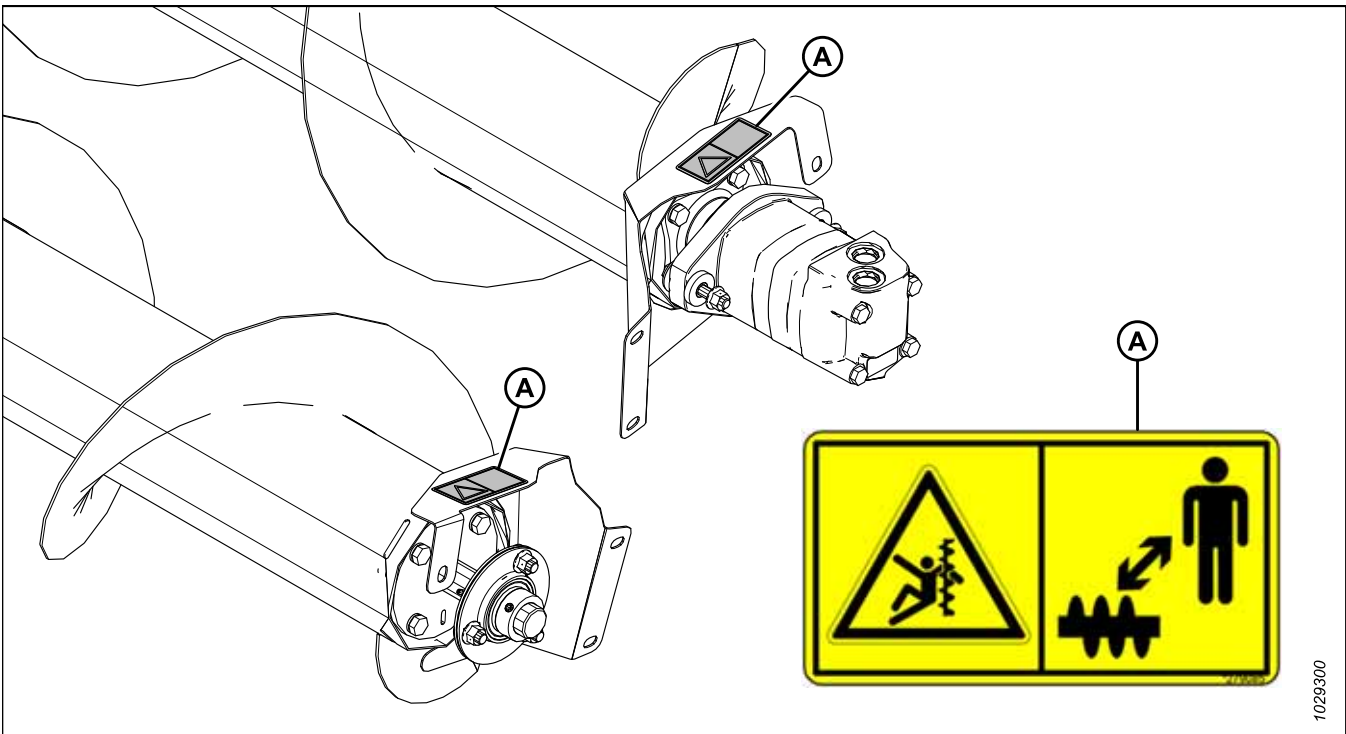
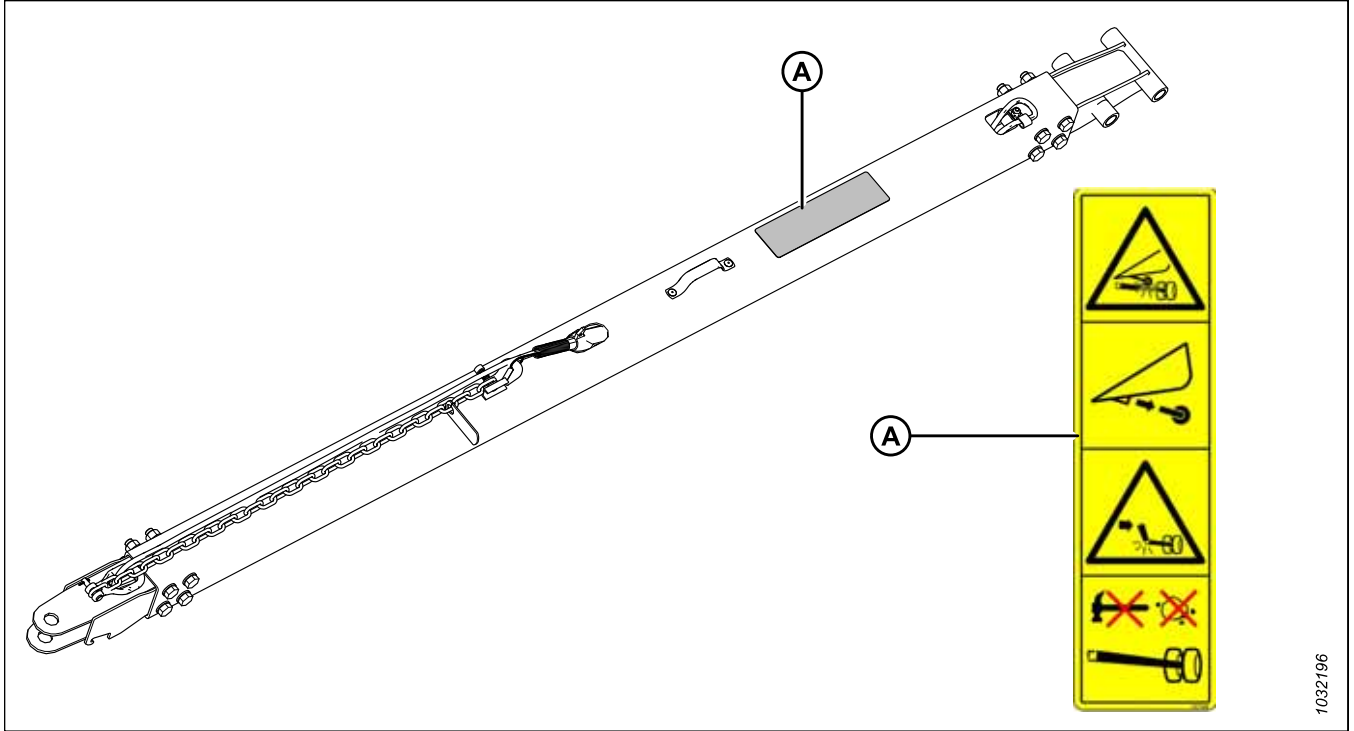


Figure 1.26: Upper Cross Auger (Optional)

A - MD #279085 – Auger Warning

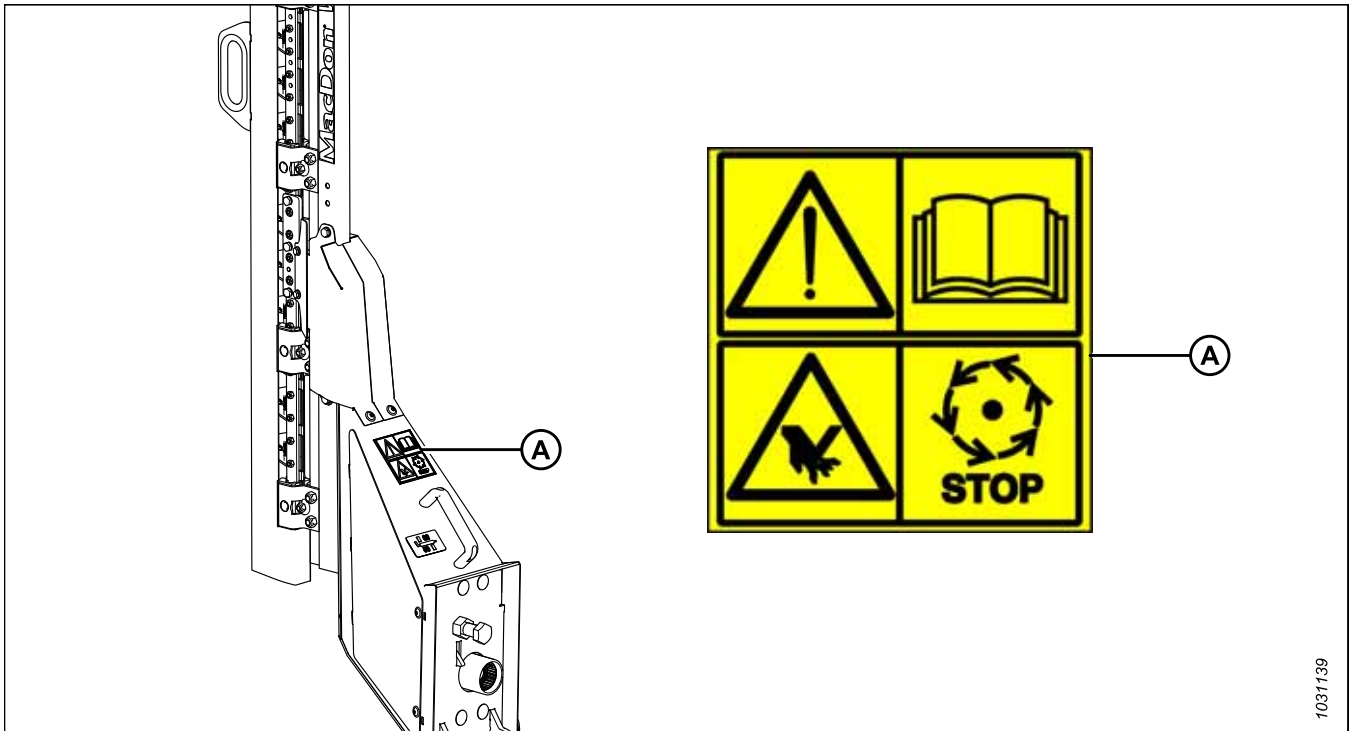
**SAFETY**



1032196

**Figure 1.27: Transport System – Tow-Bar (Short Bar Shown; Long Bar Similar) (Optional)**

A - MD #327588 – Hitch Damage Hazard



1031139

**Figure 1.28: Vertical Knife (Optional)**

A - MD #313881 – Knife Hazard

SAFETY

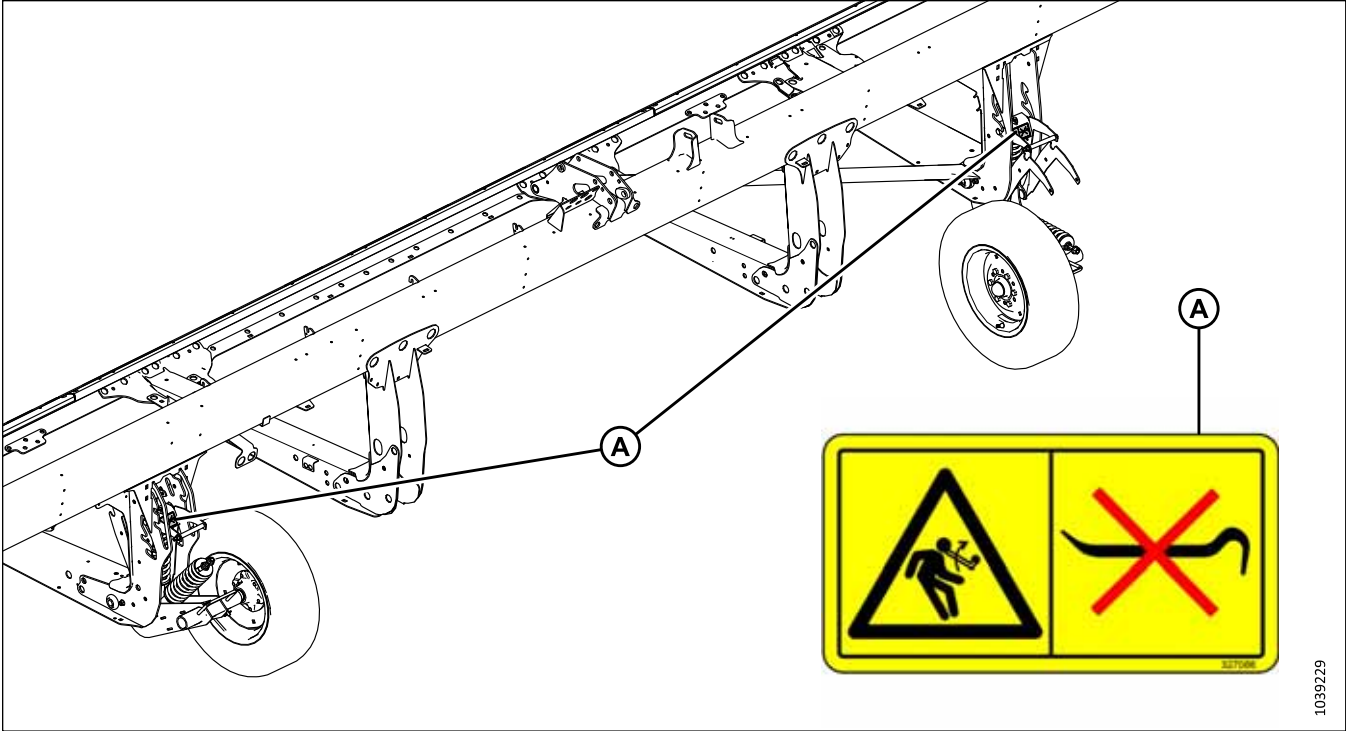


Figure 1.29: Stabilizer Wheels (Optional)

A - MD #327086 – Released Spring Energy Hazard

## 1.10 Understanding Safety Signs

Safety sign decals use illustrations to convey important safety or equipment maintenance information.

### MD #174436

High-pressure oil hazard

#### WARNING

High-pressure hydraulic fluid can penetrate human skin, which can cause serious injury such as gangrene, which can be fatal. To prevent this:

- Do **NOT** go near hydraulic fluid leaks.
- Do **NOT** use your hand to check for hydraulic fluid leaks.
- Before loosening any hydraulic fittings, relieve the pressure in the hydraulic system.
- If you are injured, seek emergency medical help. **IMMEDIATE** surgery is required to remove hydraulic fluid which has penetrated the skin.



Figure 1.30: MD #174436

### MD #220799

Loss of control hazard

#### WARNING

To prevent serious injury or death from loss of control, lock the tow-bar lock mechanism.



Figure 1.31: MD #220799

### MD #279085

Auger entanglement hazard

#### DANGER

To prevent injury from a rotating auger:

- Stand clear of the auger while the machine is running.
- Shut down the engine and remove the key from the ignition before servicing the auger.
- Do **NOT** reach into moving parts while the machine is running.



Figure 1.32: MD #279085

## SAFETY

### MD #288195

Rotating object pinch hazard

#### CAUTION

To prevent injury:

- Shut down the engine and remove the key from the ignition before opening the shield.
- Do **NOT** operate the machine without shields in place.

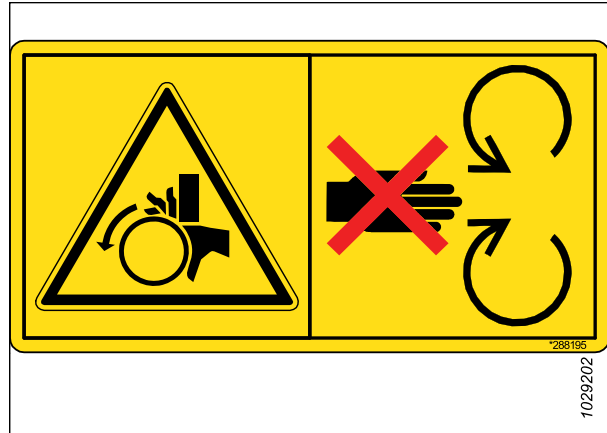


Figure 1.33: MD #288195

### MD #311493

Reel crushing hazard

#### DANGER

To prevent injury from the fall of a raised reel:

- Fully raise the reel.
- Shut down the engine, remove the key from the ignition, and engage the mechanical safety lock on each reel support arm before working on or under the reel.



Figure 1.34: MD #311493



## SAFETY

### MD #313725

Read manual / high pressure fluid / header crushing hazard

#### DANGER

To prevent injury or death from improper or unsafe machine operation:

- Read the operator's manual and follow all safety instructions. If you do not have a manual, obtain one from your Dealer.
- Do **NOT** allow untrained persons to operate the machine.
- Review safety instructions with Operators every year.
- Ensure that all of the safety signs are installed and legible.
- Ensure everyone is clear of the machine before starting the engine and during operation.
- Keep riders off of the machine.
- Keep all shields in place and stay clear of moving parts.
- Before leaving the operator's position, disengage the header drive, put the transmission in Neutral, and wait for all movement to stop.
- Shut down the engine and remove the key from the ignition before servicing the machine.
- Before servicing a unit in the raised position, engage the safety locks to prevent it from lowering unexpectedly.
- Use a slow moving vehicle emblem and flashing warning lights when operating on roadways (unless prohibited by law).

To prevent injury or death from the fall of a raised header:

- Fully raise the header, shut down the engine, remove the key from the ignition, and engage the mechanical safety locks on the combine before going under the header for any reason.
- Alternatively, fully lower the header to the ground, shut down the engine, and remove the key from the ignition before servicing the header.

#### WARNING

To prevent serious injury, gangrene, or death:

- Do **NOT** go near hydraulic leaks.
- Do **NOT** use your hand to check for leaks.
- Before loosening hydraulic fittings, relieve pressure in the hydraulic system.
- High-pressure oil can easily puncture skin, and can cause serious injury, gangrene, or death.

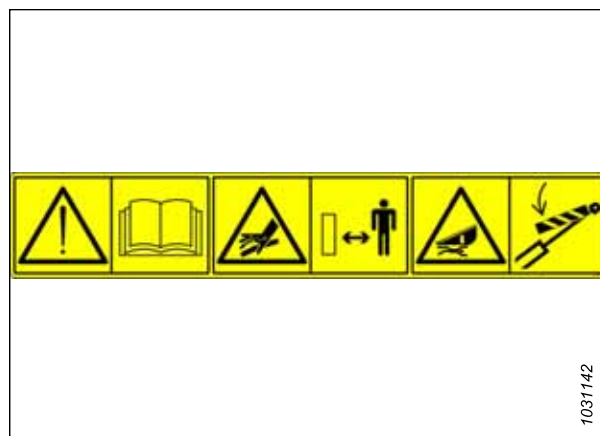


Figure 1.35: MD #313725

## SAFETY

- If you are injured, seek emergency medical help. Immediate surgery is required to remove oil.

### MD #313728

General hazard pertaining to machine operation and servicing /  
Hot fluid spray hazard

#### DANGER

To prevent injury or death from improper or unsafe machine operation:

- Read the operator's manual and follow all safety instructions. If you do not have a manual, obtain one from your Dealer.
- Do **NOT** allow untrained persons to operate the machine.
- Review safety instructions with all Operators every year.
- Ensure that all of the safety signs are installed and legible.
- Ensure everyone is clear of the machine before starting the engine and during operation.
- Keep riders off of the machine.
- Keep all shields in place and stay clear of moving parts.
- Before leaving the Operator's position, disengage the header drive, put the transmission in Neutral, and wait for all movement to stop.
- Shut down the engine and remove the key from the ignition before servicing the machine.
- Before servicing a unit in the raised position, engage the safety locks to prevent it from lowering unexpectedly.
- Use a slow moving vehicle emblem and flashing warning lights when operating on roadways (unless prohibited by law).

#### CAUTION

To prevent injury from hot fluids:

- Be aware fluid is under pressure and may be hot.
- Do **NOT** remove the fluid fill cap while the machine is hot.
- Allow the machine to cool down before opening the fluid fill cap.

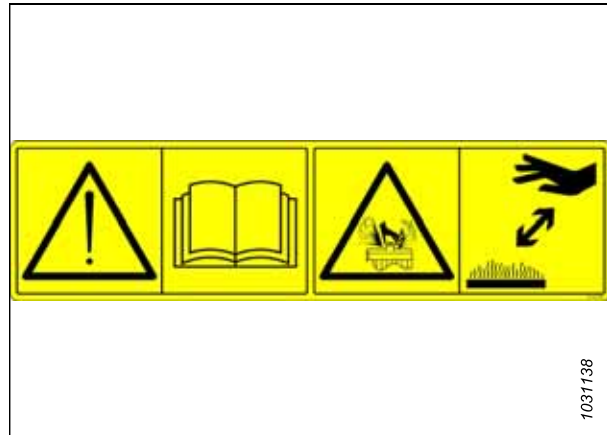


Figure 1.36: MD #313728

## SAFETY

### MD #313733

Header crushing hazard

#### DANGER

To prevent injury or death from the fall of a raised header:

- Fully raise the header, shut down the engine, remove the key from the ignition, and engage the mechanical safety locks on the combine before going under the header.
- Alternatively, fully lower the header to the ground, shut down the engine, and remove the key from the ignition before servicing the machine.



Figure 1.37: MD #313733

## SAFETY

### MD #313881

General hazard pertaining to machine operation and servicing / knife hazard

#### DANGER

To prevent injury or death from improper or unsafe machine operation:

- Read the operator's manual and follow all safety instructions. If you do not have a manual, obtain one from your Dealer.
- Do **NOT** allow untrained persons to operate the machine.
- Review safety instructions with all Operators every year.
- Ensure that all of the safety signs are installed and legible.
- Ensure that everyone is clear of the machine before starting the engine and during operation.
- Keep riders off of the machine.
- Keep all shields in place and stay clear of moving parts.
- Before leaving the operator's position, disengage the header drive, put the transmission in Neutral, and wait for all movement to stop.
- Stop the engine and remove the key from the ignition before servicing, adjusting, lubricating, cleaning, or unplugging the machine.
- Before servicing a unit in the raised position, engage the safety locks to prevent it from lowering unexpectedly.
- Use a slow moving vehicle emblem and flashing warning lights when operating on roadways (unless prohibited by law).

#### WARNING

To prevent injury from the sharp cutting knife:

- Wear suitable gloves when working with the knife.
- Ensure that no one is near the knife when removing it or rotating it.



Figure 1.38: MD #313881

## SAFETY

### MD #327086

Released spring energy hazard

#### WARNING

To prevent injury:

- When servicing wheel axle components, the lift-assist spring no longer has counterweight and becomes energized.
- Do **NOT** attempt to pry the adjustment handle out of a position slot before releasing tension from the assist springs.



Figure 1.39: MD #327086

### MD #327588

Hitch damage hazard

#### DANGER

To prevent serious injury or death:

- If the optional contour wheel system is installed, remove the left contour wheel before transporting the header.
- Do **NOT** tow a header if the transport hitch is damaged.

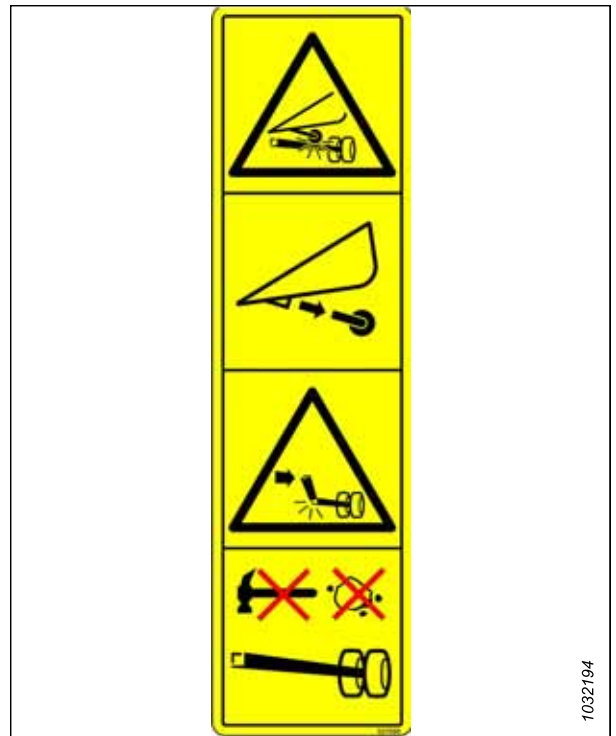


Figure 1.40: MD #327588

## SAFETY

### MD #360541

Reel entanglement / reel crushing hazard

#### DANGER

To prevent injury from entanglement with a rotating reel:

- Stand clear of the header while the machine is running.
- To prevent injury from the fall of a raised reel, fully raise the reel, shut down the engine, remove the key from the ignition, and engage the mechanical safety lock on each reel support arm before working on or under the reel.



Figure 1.41: MD #360541

### MD #360655

Released spring energy hazard

#### WARNING

To prevent serious injury:

- After pulling the float setting lever over the center, remove the multi-tool and return it to its storage location.
- Do **NOT** use the multi-tool to push the float setting lever over the center.
- Failing to return the multi-tool to its storage location can result in the multi-tool swinging upward and releasing stored energy from the spring, which can result in injury.



Figure 1.42: MD #360655

## Chapter 2: Product Overview

Refer to this section to learn the definitions of the technical terms used in this manual, the machine's specifications, and the locations of key components.

### 2.1 Definitions

The following terms, abbreviations, and acronyms are used in this manual.

**Table 2.1 Definitions**

Term	Definition
AHHC	Automatic header height control
API	American Petroleum Institute
Bolt	A headed and externally threaded fastener designed to be paired with a nut
Center-link	A hydraulic cylinder or manually adjustable turnbuckle type connection between the header and the vehicle, which is used to change the angle of the header relative to the vehicle
CGVW	Combined gross vehicle weight
DWA	Double Windrow Attachment
Export header	The header configuration typical outside North America
FD2 Series Header	MacDon FD225, FD230, FD235, FD240, FD241, FD245, and FD250 FlexDraper® Headers
FFFT	Flats from finger tight
Finger tight	A reference position in which the given sealing surfaces or components are making contact with each other. The fitting has been tightened by hand to a point where the fitting is no longer loose and cannot be tightened further by hand
FM200	The float module used with a D2 or FD2 Series Draper Header for combining
FSI	Float setting indicator
GVW	Gross vehicle weight
Hard joint	A joint made with use of a fastener where joining materials are highly incompressible
Hex key	A tool of hexagonal cross-section used to drive bolts and screws that have a hexagonal socket in the head (internal-wrenching hexagon drive); also known as an Allen key
IHS	Integrated hydraulic system
MHS	Modular hydraulic system
n/a	Not applicable
North American header	The header configuration typical in North America
Nut	An internally threaded fastener designed to be paired with a bolt
ORB	O-ring boss: A style of fitting commonly used in port openings on manifolds, pumps, and motors
ORFS	O-ring face seal: A style of fitting commonly used for connecting hoses and tubes. This style of fitting is also commonly called ORS, which stands for O-Ring Seal
PTO	Power take-off
rpm	Revolutions per minute
SAE	Society of Automotive Engineers
Screw	A headed and externally threaded fastener that threads into preformed threads or forms its own thread when it is inserted into a mating part
Soft joint	A flexible joint made by use of a fastener in which the joining materials compress or relax over a period of time

**PRODUCT OVERVIEW**

**Table 2.1 Definitions (continued)**

Term	Definition
spm	Strokes per minute
Tension	An axial load placed on a bolt or screw, usually measured in Newtons (N) or pounds (lb.). This term can also be used to describe the force a belt exerts on a pulley or sprocket
TFFT	Turns from finger tight
Torque	The product of a force * the length of a lever arm, usually measured in Newton-meters (Nm), foot-pounds (lbf·ft), or inch-pounds (lbf·in)
Torque angle	A tightening procedure in which a fitting is assembled to a specified tightness (usually finger tight) and then the nut is turned farther by a specified number of degrees until it achieves its final position
Torque-tension	The relationship between the assembly torque applied to a piece of hardware and the axial load it induces in a bolt or screw
UCA	Upper cross auger
Untimed (knife drive)	Unsynchronized motion applied at the cutterbar to two separately driven knives from a single hydraulic motor or from two hydraulic motors
Washer	A thin cylinder with a hole or a slot located in the center, used as a spacer, a load distribution element, or a locking mechanism



## PRODUCT OVERVIEW

### 2.2 Product Specifications

Use the specification table to reference information about a machine's specific configuration. The table lists dimensions, weights, performance ranges, and features.

**NOTE:**

Specifications are subject to change without notice.

The following symbols and letters are used in specification tables:

– S: standard / O<sub>F</sub>: optional (factory installed) / O<sub>D</sub>: optional (dealer installed) / –: not available

Cutterbar		
Effective cutting width (distance between crop divider points; cut width plus divider gather)		
FD225		7.7 m (301 in.)
FD230		9.2 m (361 in.)
FD235		10.7 m (421 in.)
FD240		12.2 m (481 in.)
FD241		12.5 m (493 in.)
FD245		13.7 m (541 in.)
FD250		15.3 m (601 in.)
Cutterbar lift range		Varies with combine model
Knife		
Single-knife drive (FD225–FD240): hydraulic motor mounted to enclosed heavy duty MacDon knife drive box on the left side of header.		O <sub>F</sub>
Double-knife drive (FD235–FD250): one hydraulic motor, untimed, one mounted to enclosed heavy-duty MacDon knife drive box on each side of the header.		O <sub>F</sub>
Knife stroke		76 mm (3 in.)
Single-knife speed (strokes per minute)	FD225, FD235	1200–1400 spm
Single-knife speed (strokes per minute)	FD230	1200–1500 spm
Single-knife speed (strokes per minute)	FD240	1200–1300 spm
Double-knife speed (strokes per minute)	FD235, FD240, FD241, FD245, FD250	1200–1500 spm
Knife Sections		
Over-serrated, ultra coarse, ClearCut™, QuickChange, bolted, 1.5 serrations per cm (4 serrations per inch)		O
Over-serrated, coarse, ClearCut™, QuickChange, bolted, 3.5 serrations per cm (9 serrations per inch)		S
Over-serrated, fine, ClearCut™, QuickChange, bolted, 5.5 serrations per cm (14 serrations per inch)		O
Knife overlap at center (double-knife headers)		3 mm (1/8 in.)
Guards and Hold-Downs		
<b>Guard:</b> ClearCut™ pointed, forged and double heat treated (DHT) <b>Hold-down:</b> forged, single adjustment bolt		O <sub>F</sub>
<b>Guard:</b> ClearCut™ four point, forged and double heat treated (DHT) <b>Hold-down:</b> forged, single adjustment bolt		O <sub>F</sub>
<b>Guard:</b> ClearCut™ PlugFree™, forged and double heat treated (DHT) <b>Hold-down:</b> forged, dual adjustment bolts		O <sub>F</sub>
Cutterbar Wearplates and Standard Skid Shoes		
The FD2 Series includes wearplates across the width of the cutterbar.		S
FD225		4 Skid Shoes

## PRODUCT OVERVIEW

FD230, FD235, FD240, FD241, FD245, FD250		6 Skid Shoes	S	
<b>Guard Angle (Cutterbar on the Ground)</b>				
Center-link retracted		1.7 degrees	S	
Center-link extended		8.9 degrees	S	
<b>Draper and Decks</b>				
Draper width		1.27 m (50 in.)	S	
Draper drive		Hydraulic	S	
Draper speed: FM200 Float Module controlled		209 m/min. (687 fpm)	S	
Delivery opening width		1905 mm (75 in.)	S	
<b>PR15 Pick-Up Reel</b>				
Quantity of tine tubes		5 or 6		
Center tube diameter		203 mm (8 in.)	S	
Finger tip radius	Factory-set	800 mm (31 1/2 in.)	S	
Finger tip radius	Adjustment range	766–800 mm (30 3/16–31 1/2 in.)	S	
Effective reel diameter (via shaped cam action)		1.650 m (65 in.)	S	
Finger length		290 mm (11 in.)	S	
Finger spacing (nominal, staggered on alternate bats)		100 mm (4 in.)	S	
Reel drive		Hydraulic	S	
Reel speed (adjustable from cab, varies with combine model)		0–67 rpm	S	
<b>Header Frame Flex Range</b>				
Header Model	Up – Standard	Down – Standard	Up – Limiter Removed	Down – Limiter Removed <sup>1</sup>
FD225	102 mm (4 in.)	64 mm (2.5 in.)	102 mm (4 in.)	102 mm (4 in.)
FD230	165 mm (6.5 in.)	130 mm (5 in.)	165 mm (6.5 in.)	165 mm (6.5 in.)
FD235	205 mm (8 in.)	130 mm (5 in.)	205 mm (8 in.)	205 mm (8 in.)
FD240 DR <sup>2</sup>	205 mm (8 in.)	130 mm (5 in.)	205 mm (8 in.)	205 mm (8 in.)
FD240 TR <sup>3</sup>	205 mm (8 in.)	205 mm (8 in.)	205 mm (8 in.)	205 mm (8 in.)
FD241	205 mm (8 in.)	130 mm (5 in.)	205 mm (8 in.)	205 mm (8 in.)
FD245	216 mm (8.5 in.)	216 mm (8.5 in.)	216 mm (8.5 in.)	216 mm (8.5 in.)
FD250	216 mm (8.5 in.)	216 mm (8.5 in.)	216 mm (8.5 in.)	216 mm (8.5 in.)
<b>FM200 Float Module</b>				
Feed draper	Width	2 m (78 11/16 in.)	S	
Feed draper	Speed	107–122 m/min (350–400 fpm)	S	
Feed auger	Width	1.630 m (64 1/8 in.)	S	

1. To avoid cutting off reel fingers, a greater cutterbar clearance is required when the header flex range is increased. For more information, refer to [Disabling Flex Frown Limiter](#).
2. Double reel
3. Triple reel

## PRODUCT OVERVIEW

Feed auger	Outside diameter	559 mm (22 in.)	S
Feed auger	Tube diameter	356 mm (14 in.)	S
Feed auger	Speed (varies with combine model)	191–195 rpm (varies with combine model)	S
Oil reservoir capacity		95 liters (25 US gallons)	S
Oil type		Single grade transmission/ hydraulic fluid (THF)	—
THF viscosity at 40°C (104°F)		60.1 cSt	—
THF viscosity at 100°C (212°F)		9.5 cSt	—
<b>Upper Cross Auger</b>			<b>O<sub>D</sub></b>
Outside diameter		330 mm (13 in.)	—
Tube diameter		152 mm (6 in.)	—
<b>Stabilizer Wheel / EasyMove™ Transport</b>			<b>O<sub>D</sub></b>
Wheels		38 cm (15 in.)	—
Tires		225/75 R-15	—
<b>Weight</b>			
Estimated weight range – base header with float module – variances are due to different package configurations.			
<b>Header Model</b>	<b>Market Region</b>	<b>Weight Range – kg (lb.)</b>	
FD225	North America	3365–3468 (7403–7629)	
FD230	North America	3731–3843 (8208–8454)	
FD235	North America	3931–4135 (8648–9097)	
FD240	North America	4069–4404 (8951–9688)	
FD241	Export	4307–4430 (9475–9746)	
FD245	North America	4548–4680 (10,005–10,296)	
	Export	4,685–4,817 (10,307–10,597)	
FD250	North America	4733–4870 (10,412–10,714)	
	Export	4967–5030 (10,927–11,066)	

## 2.3 FD2 Series FlexDraper® Header Dimensions

When operating a header, it is important to know the dimensions of the machine.

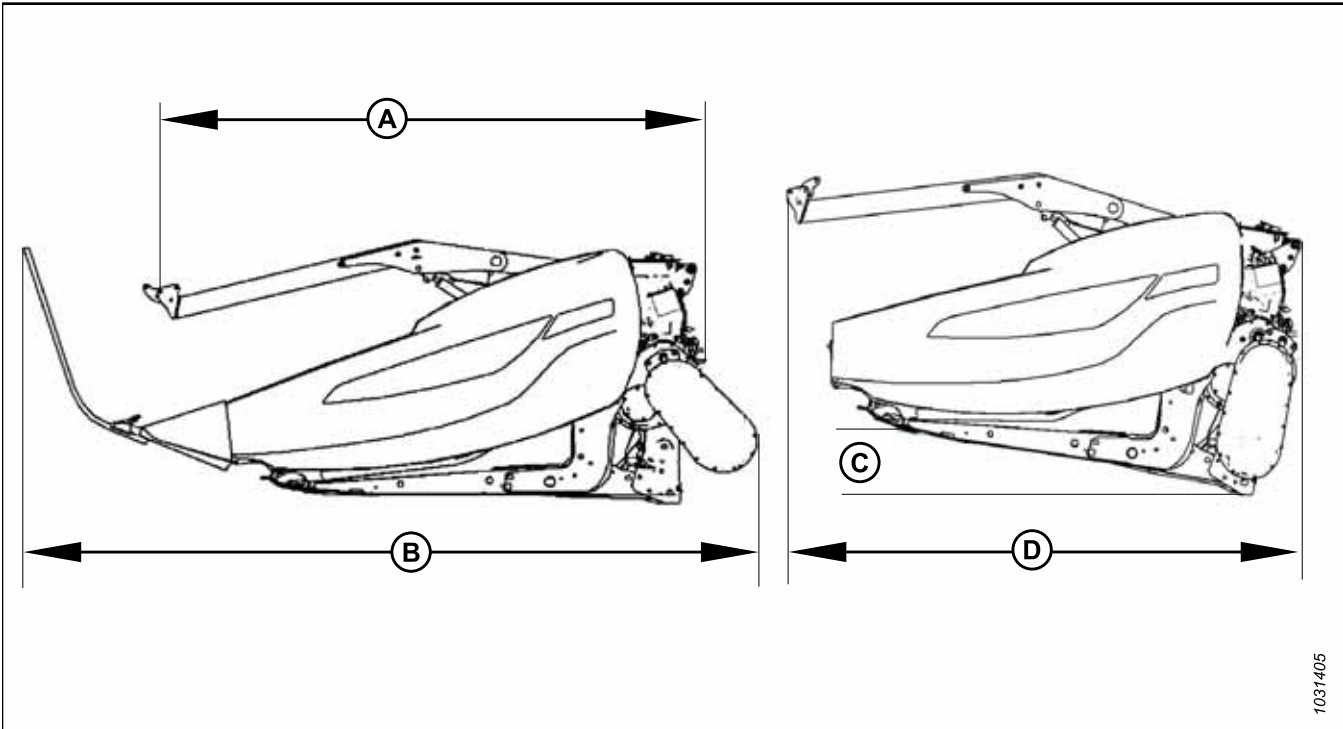


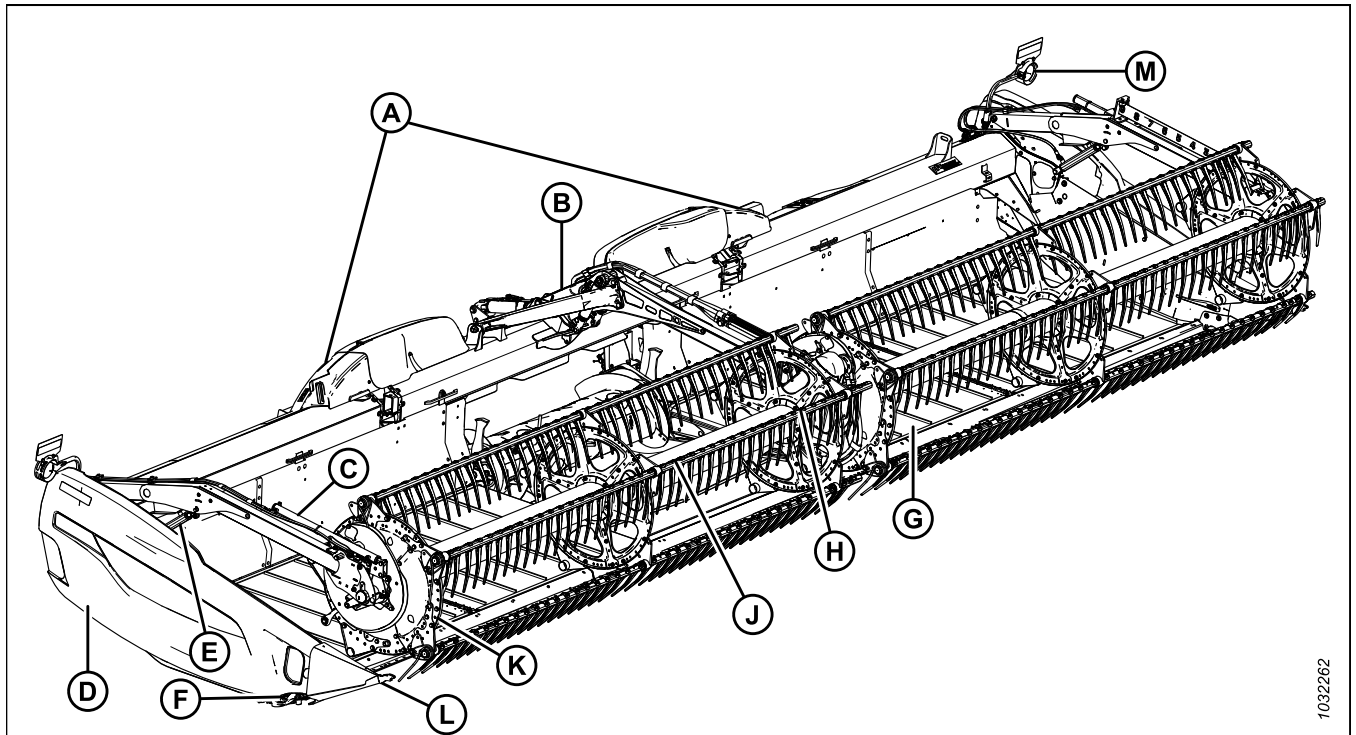
Figure 2.1: Header Dimensions

Table 2.2 Header Dimensions

Frame and Structure		
Feature Being Measured	Reference to Figure 2.1, page 32	Dimension
Header width in field mode	—	Cut width + 500 mm (19 1/5 in.)
Cutterbar width	—	Cut width - 500 mm (19 1/5 in.)
Header width in transport position with FM200 installed (shortest center-link)	(A) Gearbox rotated (storage), dividers removed (refer to 2.1, page 32)	2.6 m (103 in.)
Header width in transport position with FM200 installed (shortest center-link)	(B) Gearbox operational, standard dividers installed (refer to 2.1, page 32)	3.5 m (138 in.)
Header width in transport position with reel fully retracted and FM200 installed (shortest center-link)	Gearbox rotated, dividers removed (refer to 2.1, page 32)  Angle (C) required to achieve transport width (D)  <b>NOTE:</b> Dimension (D) can be decreased by using a transport trailer with greater angle.	8° 2.591 m (102 in.)

## 2.4 FD2 Series FlexDraper® Header Component Identification

Familiarizing yourself with the main components of the header will make it easier to follow the operation and maintenance instructions provided in this manual.



1032262

Figure 2.2: FD2 Series FlexDraper® Header Components

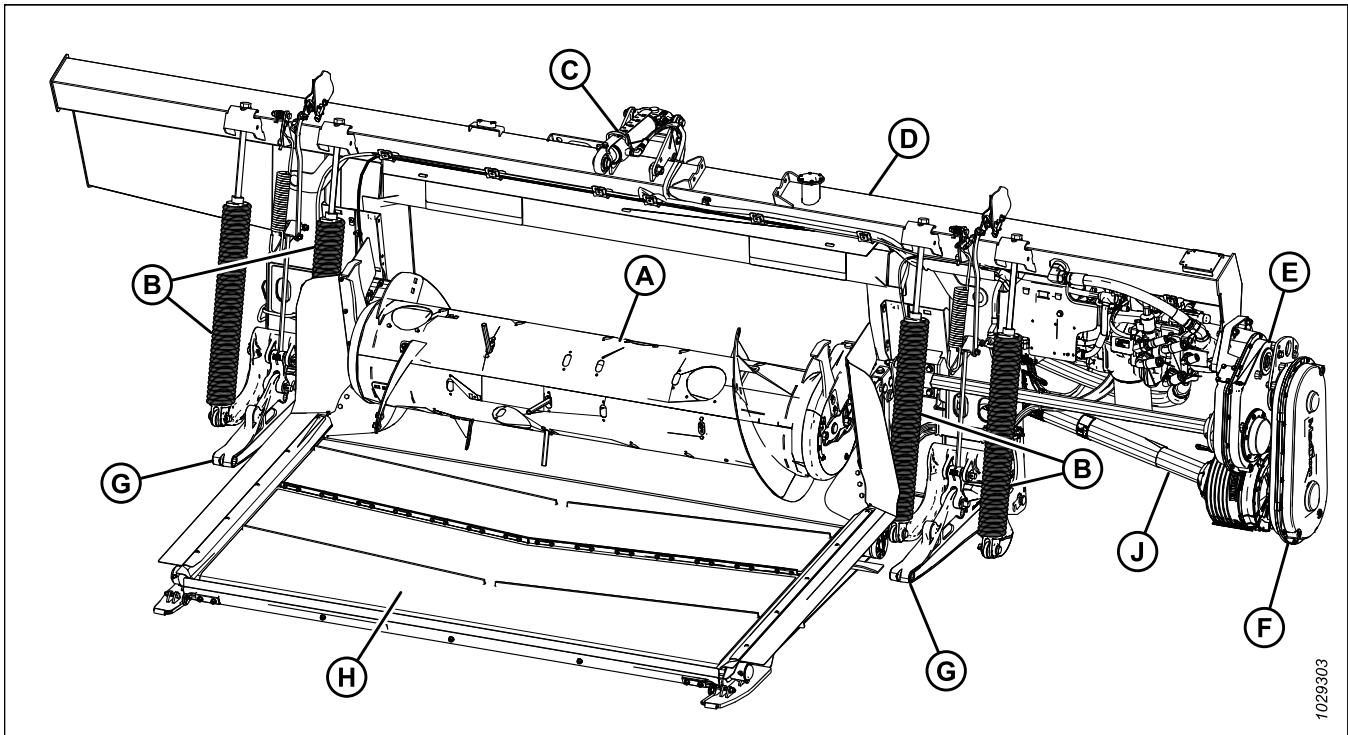
A - Wing Float Linkage  
 D - Endshield  
 G - Side Draper  
 K - Reel Endshield

B - Center Reel Arm  
 E - Reel Lift Cylinder  
 H - Center Reel Drive  
 L - Crop Divider

C - Reel Fore-Aft Cylinder  
 F - Knife Drive Box (inside endshield)  
 J - Pick-up Reel  
 M - Header Light (except Europe)

## 2.5 FM200 Float Module Component Identification

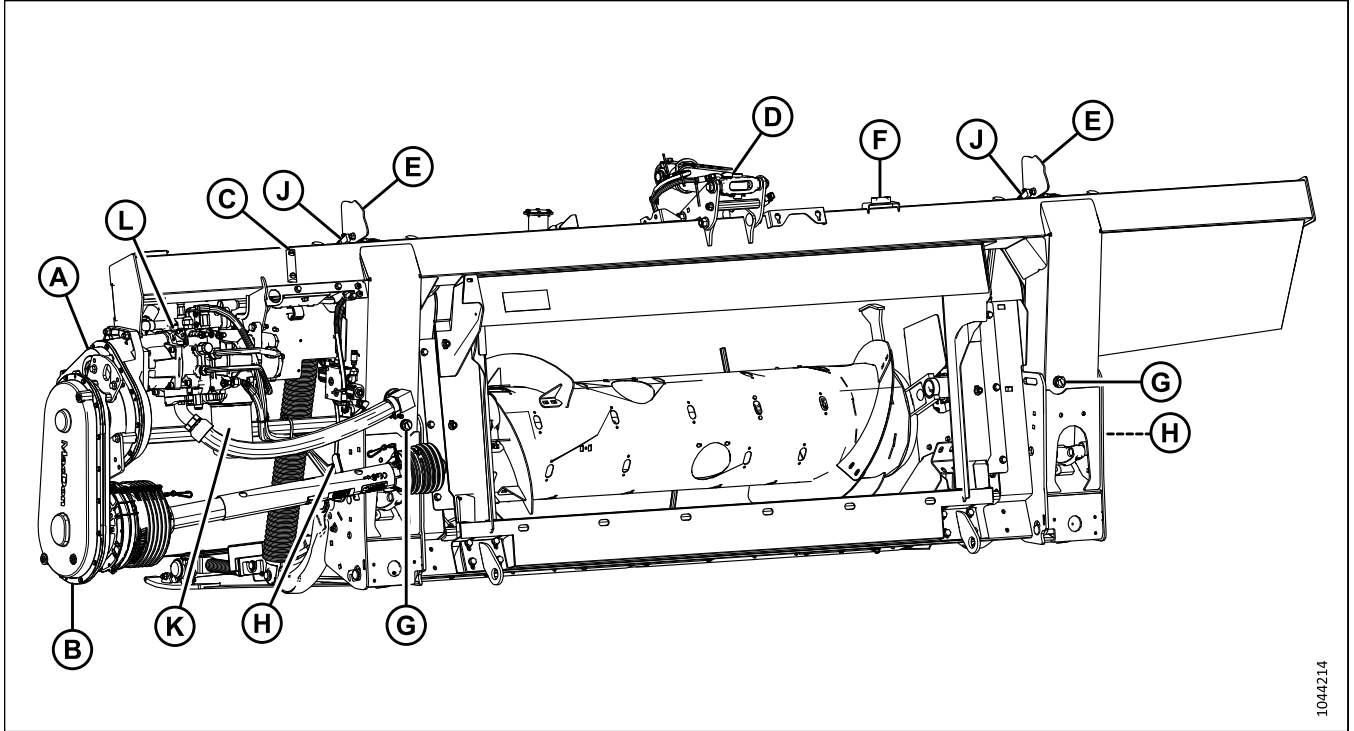
Familiarizing yourself with the main components of the float module will make it easier to follow the instructions provided in this manual.



**Figure 2.3: Header Side of FM200 Float Module with Integrated Hydraulic System (IHS)**

- |                              |                               |                        |
|------------------------------|-------------------------------|------------------------|
| A - Feed Auger               | B - Header Float Springs (x4) | C - Center-Link        |
| D - Hydraulic Reservoir      | E - Main Gearbox              | F - Completion Gearbox |
| G - Header Support Arms (x2) | H - Feed Draper               | J - Driveline          |

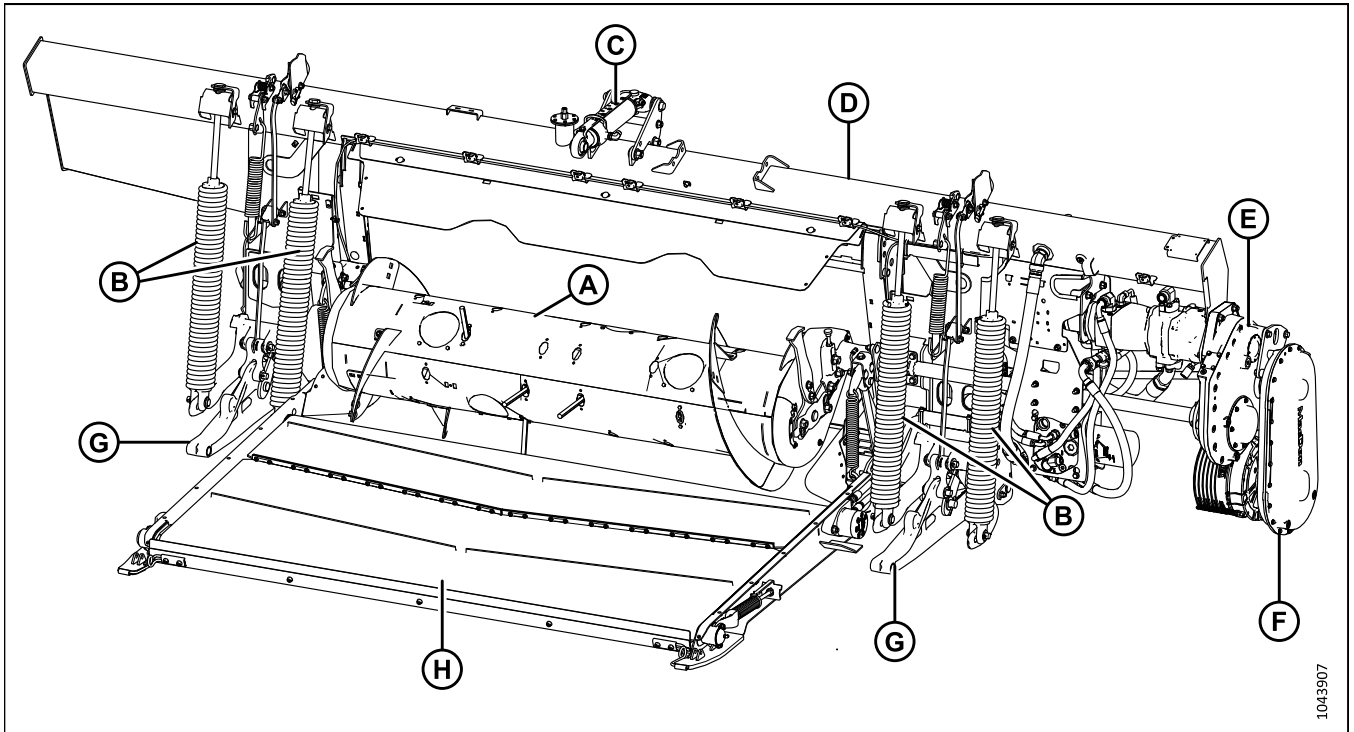
PRODUCT OVERVIEW



1044214

Figure 2.4: Combine Side of FM200 Float Module with Integrated Hydraulic System (IHS)

- |                      |  |   |
|----------------------|--|---|
| A - Main Gearbox     | B - Completion Gearbox                   | C - Reservoir Oil Level Sight Glass               |
| D - Center-Link      | E - Header Height Control Indicator (x2) | F - Bubble Level                                  |
| G - Drain Plug (x2)  | H - Float Lock Handle (x2)               | J - Auto Header Height Control (AHHC) Sensor (x2) |
| K - Hydraulic Filter | L - Integrated Pump                      |   |

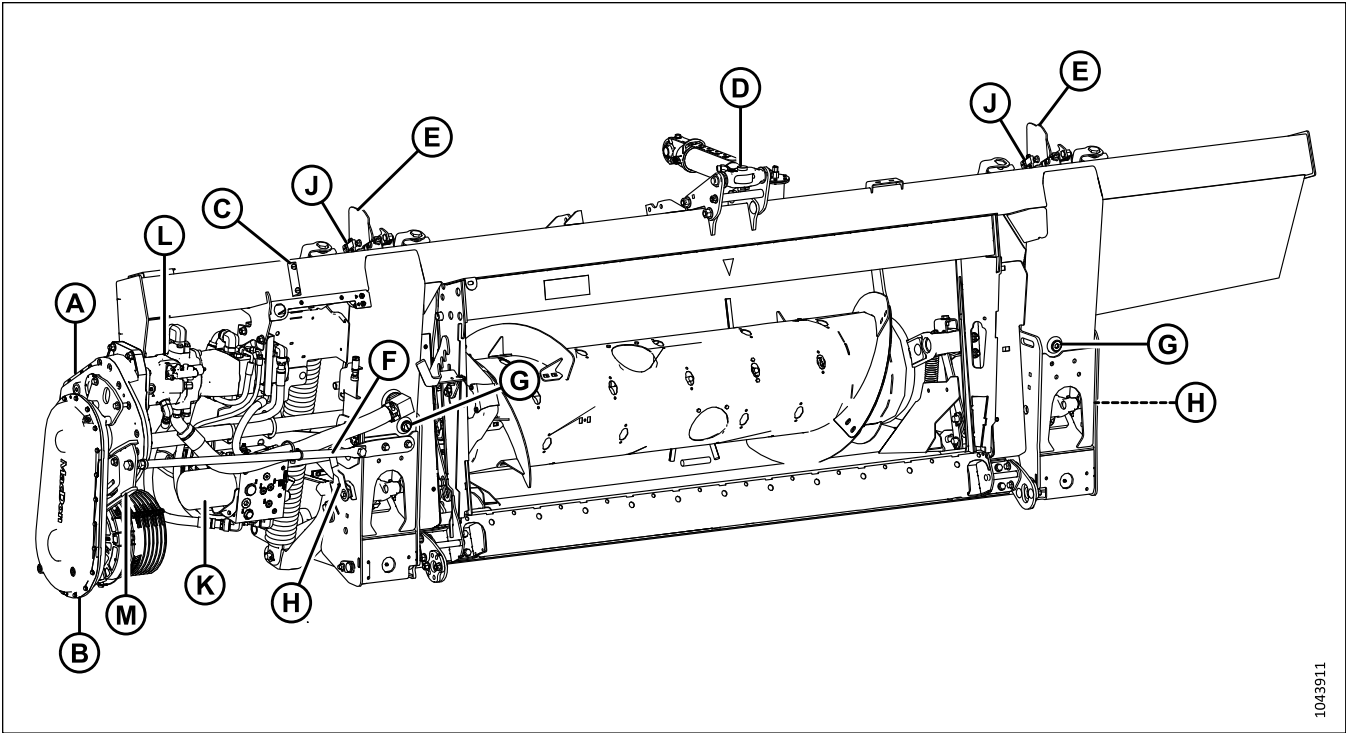


1043907

Figure 2.5: Header Side of FM200 Float Module with Modular Hydraulic System (MHS)

- |                              |                               |                        |
|------------------------------|-------------------------------|------------------------|
| A - Feed Auger               | B - Header Float Springs (x4) | C - Center-Link        |
| D - Hydraulic Reservoir      | E - Main Gearbox              | F - Completion Gearbox |
| G - Header Support Arms (x2) | H - Feed Draper               | J - Driveline          |

PRODUCT OVERVIEW



1043911

Figure 2.6: Combine Side of FM200 Float Module with Modular Hydraulic System (MHS)

- |                      |  |   |
|----------------------|--|---|
| A - Main Gearbox     | B - Completion Gearbox                   | C - Reservoir Oil Level Sight Glass               |
| D - Center-Link      | E - Header Height Control Indicator (x2) | F - Drive Support                                 |
| G - Drain Plug (x2)  | H - Float Lock Handle (x2)               | J - Auto Header Height Control (AHHC) Sensor (x2) |
| K - Hydraulic Filter | L - Modular Pump                         | M - Brace Support                                 |



## Chapter 3: Operation

Safely operating your machine requires familiarizing yourself with its capabilities.

### 3.1 Owner/Operator Responsibilities

Owning and operating heavy equipment comes with certain duties.



#### CAUTION

- It is your responsibility to read and understand this manual completely before operating the header. Contact your MacDon Dealer if an instruction is not clear to you.
- Follow all safety messages in the manual and on safety decals on the machine.
- Remember that YOU are the key to safety. Good safety practices protect you and the people around you.
- Before allowing people to operate the header, for however short a time or distance, make sure they have been instructed in its safe and proper use.
- Review the manual and all safety related items with all Operators annually.
- Be alert for other Operators not using recommended procedures or not following safety precautions. Correct these mistakes immediately, before an accident occurs.
- Do NOT modify the machine. Unauthorized modifications may impair the function and/or safety of the machine and may reduce the length of service you receive from your machine.
- The safety information given in this manual does not replace safety codes, insurance needs, or laws governing your area. Be sure your machine meets the standards set by these regulations.

## 3.2 Operational Safety

Follow all the safety and operational instructions given in this manual.

### CAUTION

Adhere to the following safety precautions:

- Follow all safety and operational instructions provided in your operator's manuals. If you do not have a combine manual, get one from your Dealer and read it thoroughly.
- Never attempt to start the engine or operate the machine except from the operator's seat.
- Check the operation of all controls in a safe, clear area before starting work.
- Do NOT allow riders on the combine.



Figure 3.1: No Riders

### CAUTION

- Never start or move the machine until you are sure all bystanders have cleared the area.
- Avoid travelling over loose fill, rocks, ditches, or holes.
- Drive slowly through gates and doorways.
- When working on inclines, travel uphill or downhill whenever possible. Be sure to keep the transmission in gear when travelling downhill.
- Never attempt to get on or off a moving machine.
- Do NOT leave the operator's station while the engine is running.
- To avoid bodily injury or death from the unexpected startup of a machine, always stop the engine and remove the key before adjusting or removing plugged material from the machine.
- Check for excessive vibration and unusual noises. If there is any indication of trouble, shut down and inspect the machine. Follow the proper shutdown procedure. For instructions, refer to [3.4 Shutting Down Combine, page 59](#).
- Operate only in daylight or good artificial light.

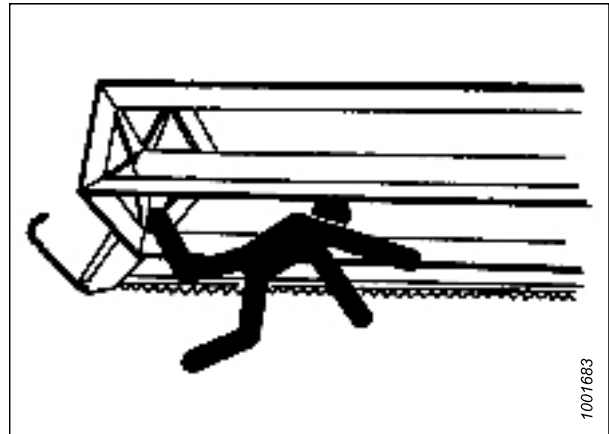


Figure 3.2: Bystander Safety

### 3.2.1 Header Safety Props

The header safety props located on the header lift cylinders prevent the lift cylinders from unexpectedly retracting and lowering the header. For operation instructions, refer to your combine operator's manual.

### DANGER

To prevent bodily injury or death from the unexpected start-up or fall of a raised machine, always stop the engine, remove the key, and engage the safety props before going under the header for any reason.

### 3.2.2 Reel Safety Props

The reel safety props are located on the reel arms. When engaged, the reel safety props prevent the reel from falling unexpectedly.

**IMPORTANT:**

To prevent damage to the reel support arms, do **NOT** transport the header with the reel safety props engaged.

#### *Engaging Reel Safety Props*

Engage the reel safety props anytime you need to work around a raised reel. When the reel safety props are engaged, they prevent the reel from unexpectedly lowering.

**⚠ DANGER**

Ensure that all bystanders have cleared the area.

**⚠ DANGER**

To prevent injury or death from the unexpected start-up of the machine, always stop the engine and remove the key from the ignition before leaving the operator's seat for any reason.

#### *Outer reel arms*

1. Raise the reel fully.
2. Shut down the engine, and remove the key from the ignition.
3. Lift up on safety prop (A) and push it forward to remove the prop from hook (B).

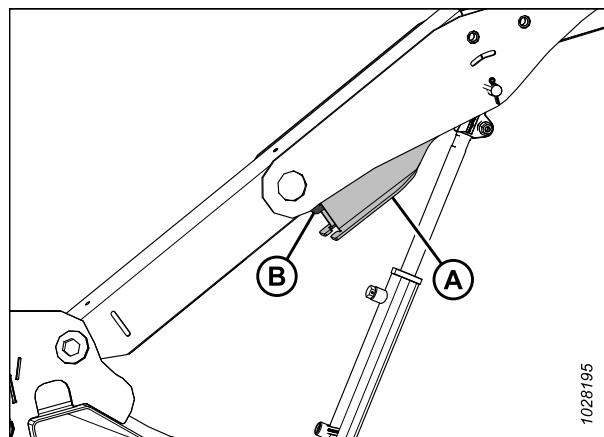


Figure 3.3: Outer Arm

4. Lower safety prop (A) and engage it on the cylinder shaft as shown. Repeat this step on the opposite reel arm.

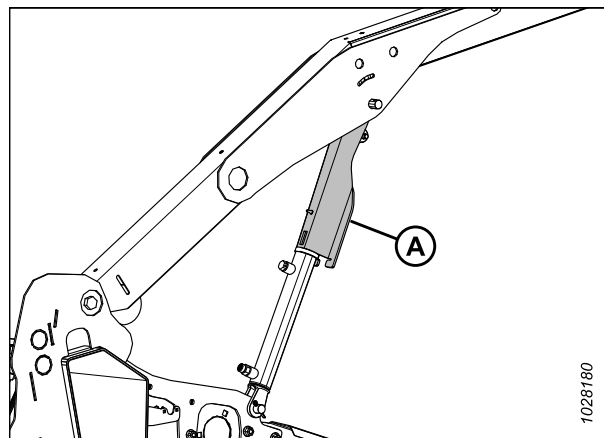


Figure 3.4: Engaged Reel Safety Prop – Outer Arm

## OPERATION

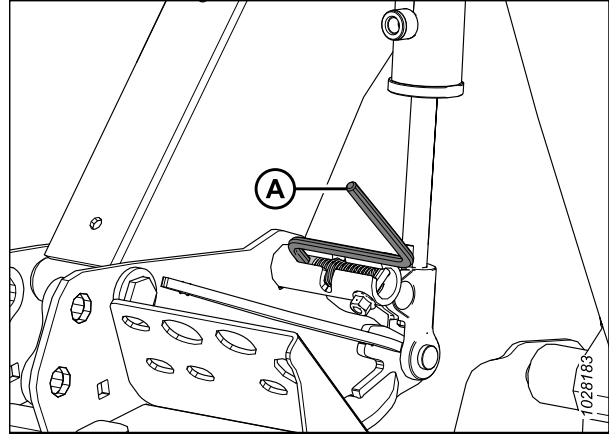
### *Center reel arm – double- and triple-reel headers*

5. Rotate handle (A) to release the spring tension and allow the spring to guide the pin into the locked position.

**NOTE:**

For triple-reel headers, the illustration shows the center right arm. The center left arm is opposite.

6. On triple-reel headers, repeat the previous step on the center left arm.
7. Lower the reel until the safety props contact the outer arm cylinder mounts and the center arm pins.
8. Shut down the engine, and remove the key from the ignition.



**Figure 3.5: Engaged Reel Safety Prop – Center Arm**

### *Disengaging Reel Safety Props*

Disengage the reel safety props once you have completed working on or around a raised reel.

**⚠ DANGER**

Ensure that all bystanders have cleared the area.

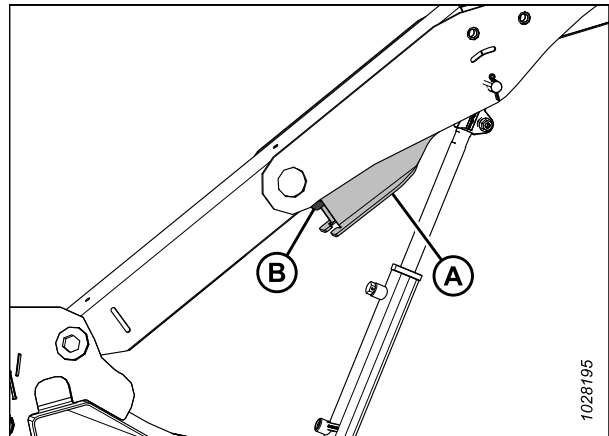
**⚠ DANGER**

To prevent injury or death from the unexpected start-up of the machine, always stop the engine and remove the key from the ignition before leaving the operator's seat for any reason.

1. Raise the reel fully.
2. Shut down the engine, and remove the key from the ignition.

### *Outer reel arms*

3. Move reel safety prop (A) up onto hook (B) under the reel arm. Repeat this step on the opposite reel arm.

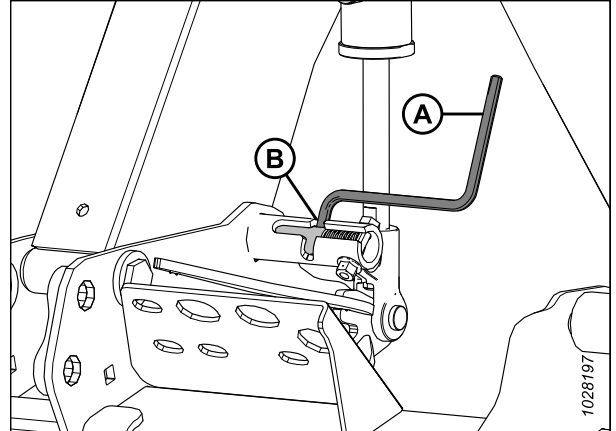


**Figure 3.6: Reel Safety Prop – Right Outer Arm**

## OPERATION

### *Center reel arm – double- and triple-reel headers*

4. Move handle (A) outboard and into slot (B) to put the pin into the unlocked position.
5. On triple-reel headers, repeat the previous step on the center left arm.
6. Lower the reel fully.
7. Shut down the engine, and remove the key from the ignition.



**Figure 3.7: Reel Safety Prop – Center Arm**

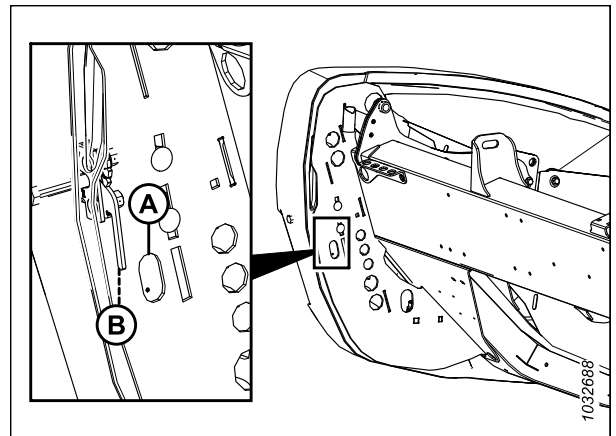
### **3.2.3 Header Endshields**

A hinged, polyethylene endshield is fitted on each end of the header to protect critical drive components.

#### *Opening Header Endshields*

The header endshields cover the knife drive components, the hydraulic hoses, the electrical connections, the header wrench, the spare knife, and the optional transport hitch. To access these components, you will need to open the endshield.

1. To unlock the shield, push release lever (B) using access hole (A) on the backside of the header endshield.



**Figure 3.8: Left Header Endshield**

## OPERATION

2. Pull header endshield (A) open.

### NOTE:

The header endshield is retained by tab (B) and will open in direction (C).

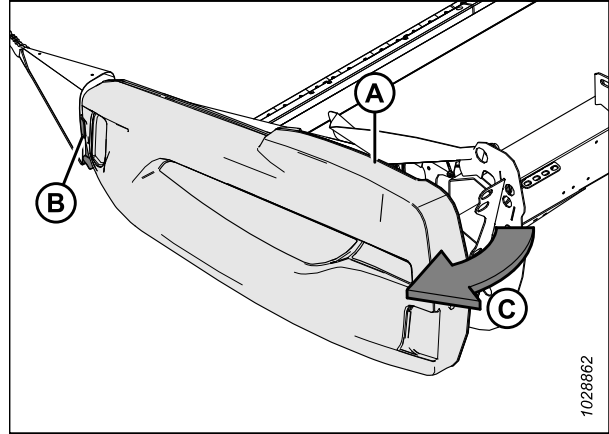


Figure 3.9: Left Header Endshield

3. If additional clearance is required, pull the header endshield free of tab (A), then swing the shield toward the rear of the header.
4. Engage safety latch (B) on hinge arm (C) to secure the shield in the fully open position.

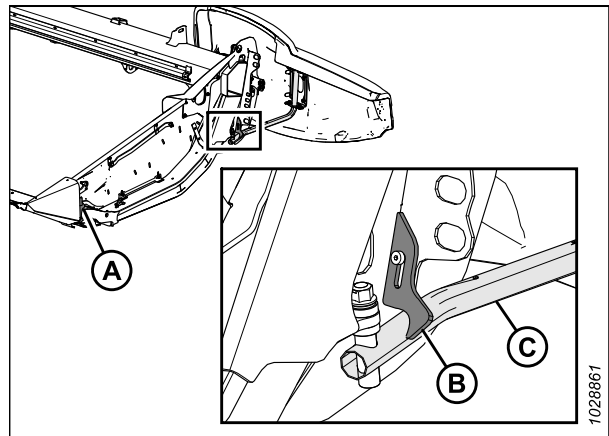


Figure 3.10: Left Header Endshield

### Closing Header Endshields

Close the header endshields to protect the drive components, the hoses, and the electrical connections from dirt and debris.

1. If the endshield is fully open and secured behind the header, disengage lock (A) to allow header endshield (B) to move.
2. Rotate the header endshield toward the front of the header.

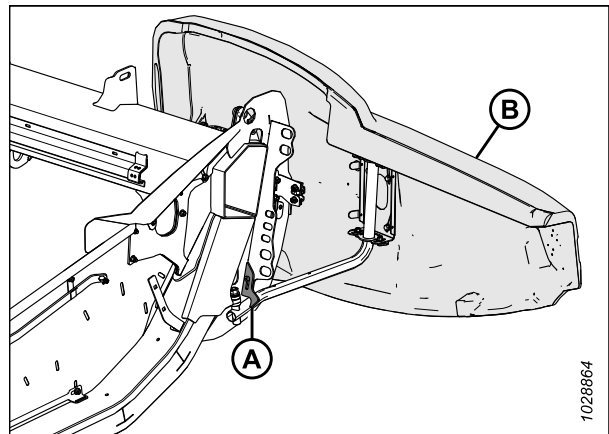


Figure 3.11: Left Header Endshield

## OPERATION

3. While closing endshield (A), ensure that it does not contact the top of endsheet (B). If adjustment is required, refer to [Checking and Adjusting Header Endshields, page 44](#).

### IMPORTANT:

Ensure that the header endshield does **NOT** rest on the aluminum endsheet.

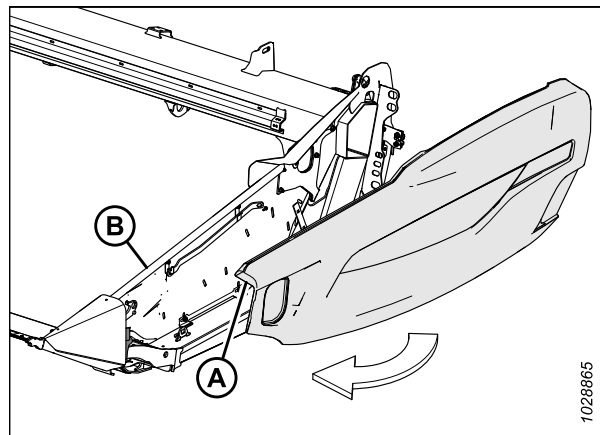


Figure 3.12: Left Header Endshield

4. Insert the front of the header endshield behind hinge tab (B) and into the divider cone.
5. Swing the header endshield in direction (A) into the closed position. Engage two-stage latch (C) with a firm push.

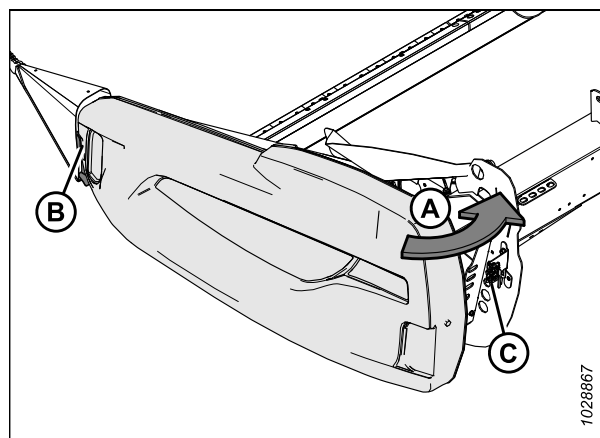


Figure 3.13: Left Header Endshield

### IMPORTANT:

To ensure that the header endshield is locked, bolt (A) must be fully engaged on two-stage latch (B) to prevent the header endshield from opening while you are operating the header. If adjustment is required, refer to [Checking and Adjusting Header Endshields, page 44](#).

### NOTE:

The header endshield is transparent in the illustration to show the latch.

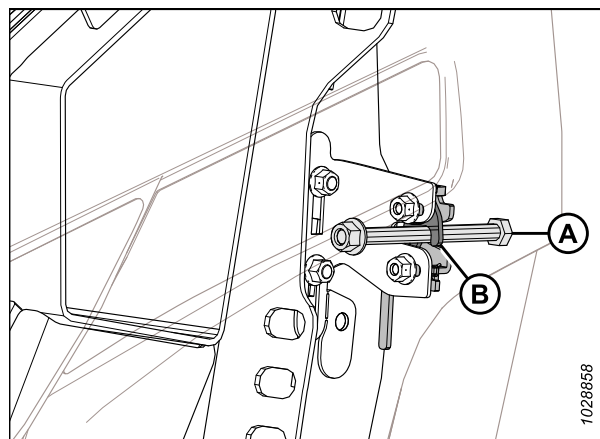


Figure 3.14: Two-Stage Latch

## OPERATION

### Checking and Adjusting Header Endshields

The header endshields can warp due to extreme changes in temperature. Adjust the position of the header endshield to compensate for dimensional changes.

#### DANGER

To prevent bodily injury or death from the unexpected start-up of the machine, always stop the engine and remove the key from the ignition before leaving the operator's seat for any reason.

1. Shut down the engine, and remove the key from the ignition.

#### IMPORTANT:

Ensure that the header endshield does **NOT** rest on the aluminum endsheet.

2. Measure clearance (A) between header endshield (B) and endsheet (C). The clearance should be 1–3 mm (1/16–1/8 in.).

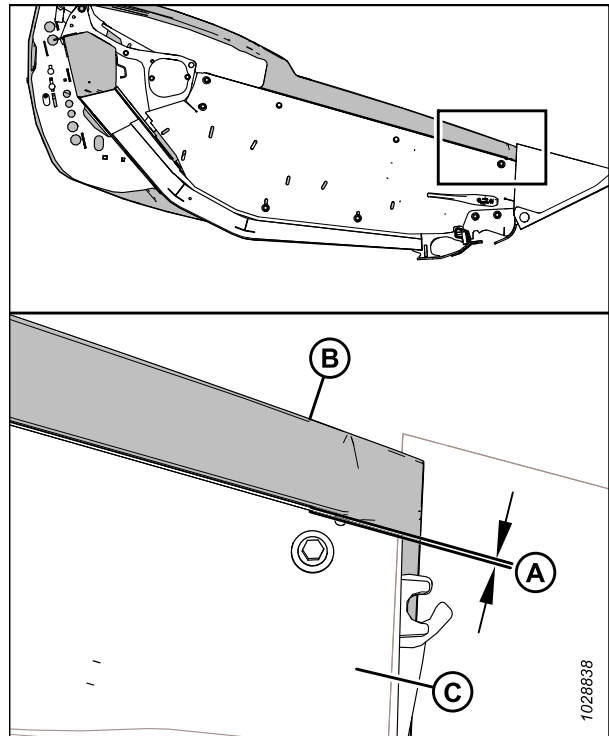


Figure 3.15: Clearance between Endshield and Endsheet



## OPERATION

3. If the clearance between the header endshield and the endsheet is insufficient, adjust support bracket (A) as follows:
  - a. Loosen bolts (B).
  - b. Move support bracket (A) up or down as needed.
  - c. Retighten the hardware.

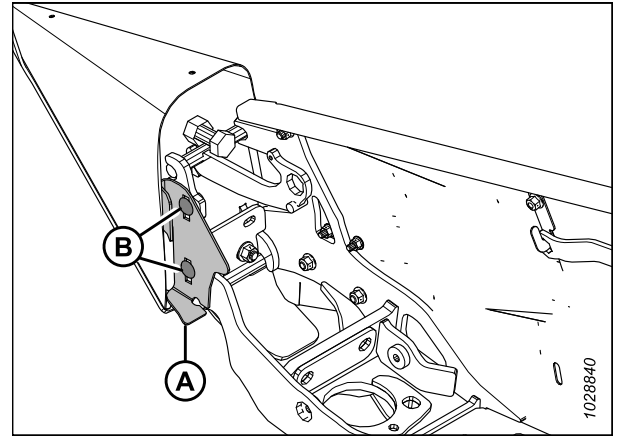
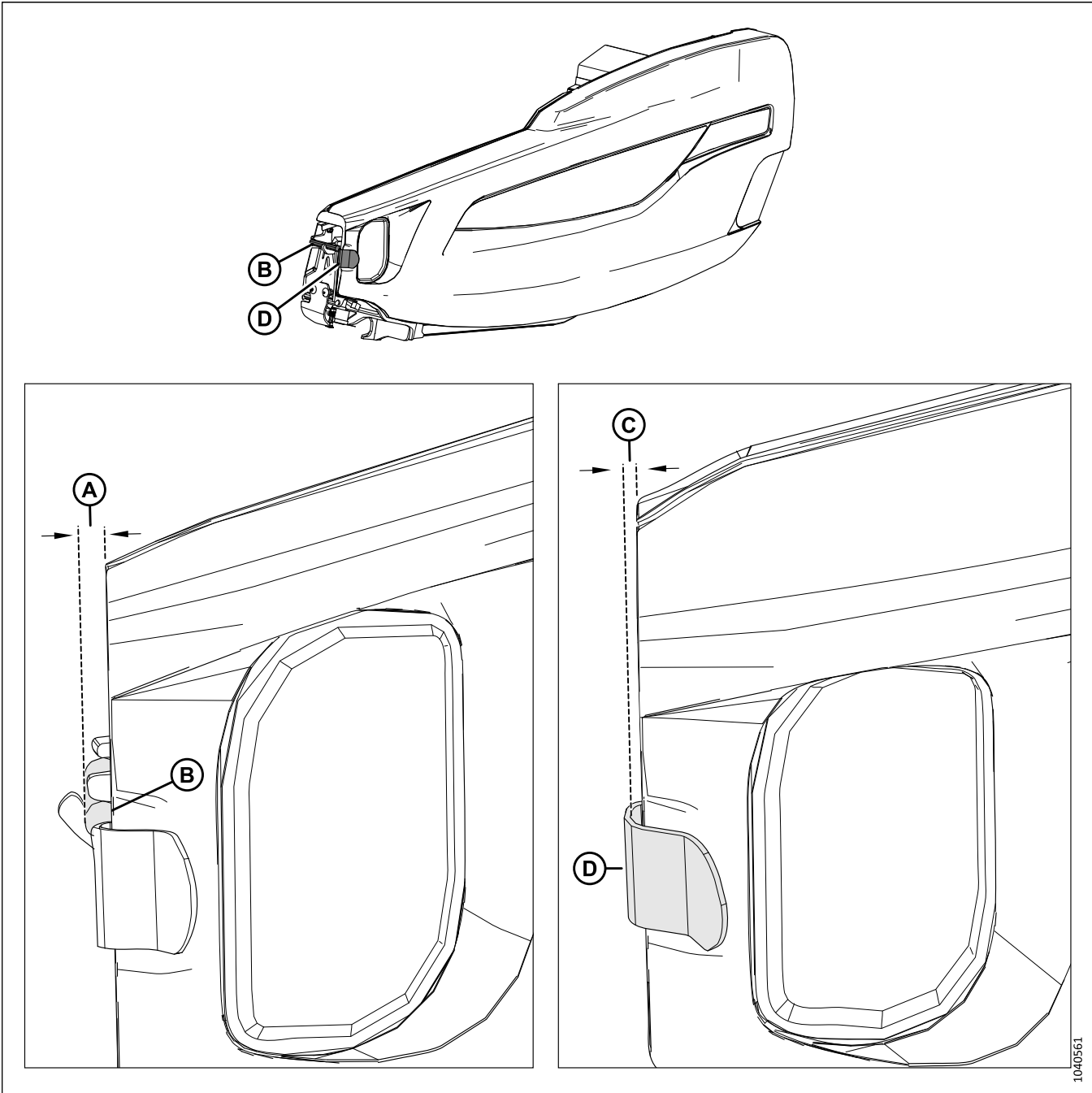


Figure 3.16: Header Endshield Support Bracket

## OPERATION



**Figure 3.17: Clearance Specifications at the Front of the Endshield**

4. Measure clearance (A) between the front of the header endshield and pin (B). The clearance should be 8–18 mm (1/32–11/16 in.).
5. Measure clearance (C) between the front of the header endshield and support bracket (D). The clearance should be 6–10 mm (1/4–3/8 in.).

## OPERATION

6. If the clearances at the front of the endshield are insufficient, adjust the position of hinge arm (A) as follows:
  - a. Loosen four nuts (B).
  - b. Slide brackets (C) and hinge arm (A) fore or aft as required to achieve the correct clearance.
  - c. Retighten the hardware.

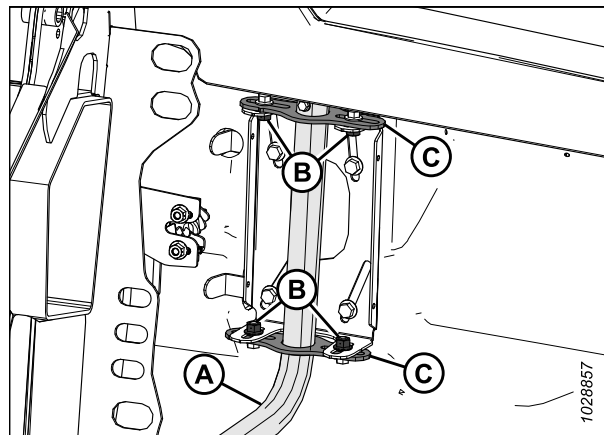


Figure 3.18: Left Header Endshield

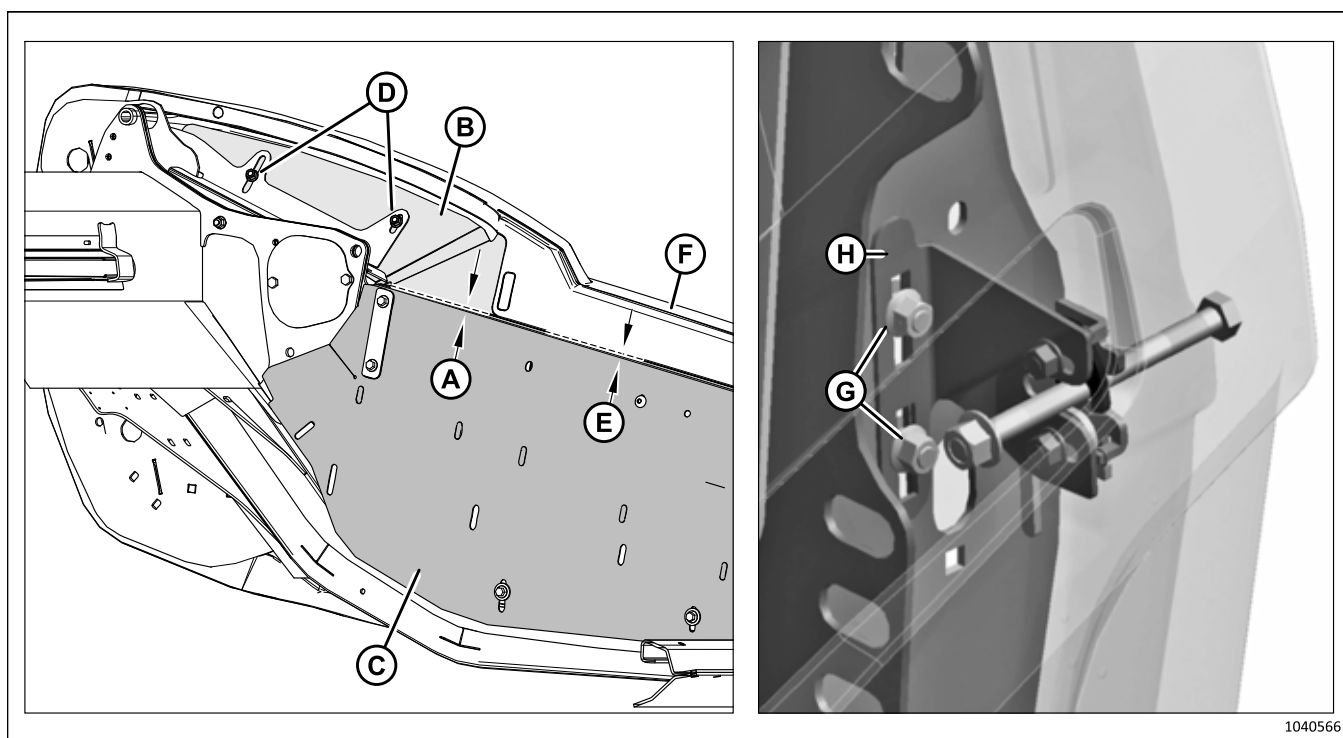
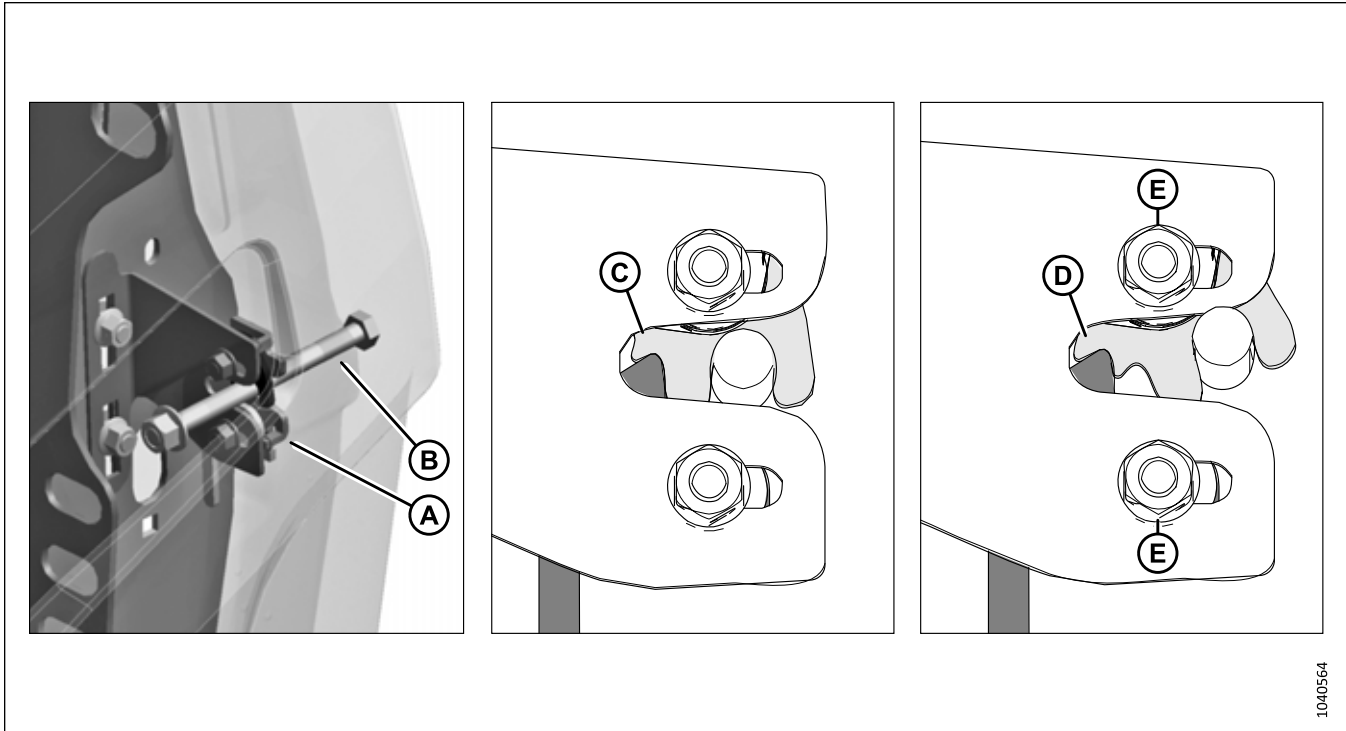


Figure 3.19: Clearance Specification between Neck Shield and End Panel

7. Measure clearance (A) between neck shield (B) and end panel (C). The clearance must be at least 3 mm (1/8 in.). To adjust the clearance, loosen two nuts (D), move neck panel (B), and tighten nuts (D).
8. Measure clearance (E) between end panel (C) and endshield (F). The clearance must be 1–3 mm (1/16–1/8 in.). To adjust the clearance, loosen two nuts (G), slide bracket (H) up or down, and tighten the nuts.

### NOTE:

Ensure that the endshield does **NOT** rest on neck panel (B).



**Figure 3.20: Two-Stage Latch**

9. When the endshield is closed, two-stage latch (A) must engage first catch (C). This will allow second catch (D) to prevent the endshield from opening completely in case the endshield unlatches by accident. Confirm the endshield latches properly by following [Step 10, page 48](#) to [Step 12, page 48](#).
10. Close the endshield. Confirm bolt (B) engages latch (A).
11. Release the latch.
12. Try to open the endshield.
  - If you can open the endshield partially, but **NOT** completely, then the latch is positioned properly.
  - If you can open the endshield completely, loosen nuts (E), move latch along the slotted holes, then retighten the nuts. Repeat [Step 10, page 48](#) to [Step 12, page 48](#).

### Removing Header Endshields

Remove the endshields to increase access to the components inside.

#### **DANGER**

**To prevent bodily injury or death from the unexpected start-up of the machine, always stop the engine and remove the key from the ignition before leaving the operator's seat for any reason.**

1. Shut down the engine, and remove the key from the ignition.

## OPERATION

2. Fully open the header endshield. For instructions, refer to [Opening Header Endshields, page 41](#).
3. Engage latch (A) to prevent the endshield from moving.
4. Remove self-tapping screw (B).
5. Slide the header endshield upward and remove it from hinge arm (C).
6. Place the header endshield away from the work area.

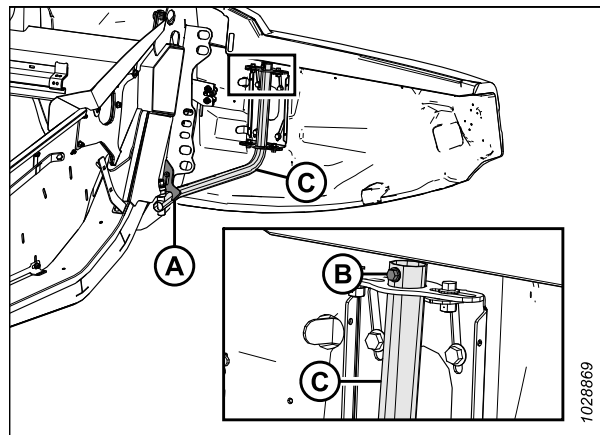


Figure 3.21: Left Header Endshield

### Installing Header Endshields

To ensure that the endshields are installed correctly, follow the procedure provided here.

1. Shut down the engine, and remove the key from the ignition.

#### IMPORTANT:

Ensure that the header endshield does **NOT** rest on the aluminum endsheet.

2. Guide the header endshield onto hinge arm (C) and slowly slide it downwards.
3. Install self-tapping screw (B).
4. Disengage latch (A) to allow the header endshield to move.
5. Close the header endshield. For instructions, refer to [Closing Header Endshields, page 42](#).

#### NOTE:

The header endshields can warp due to extreme changes in temperature. Adjust the position of the header endshield to compensate for these changes. For instructions, refer to [Checking and Adjusting Header Endshields, page 44](#).

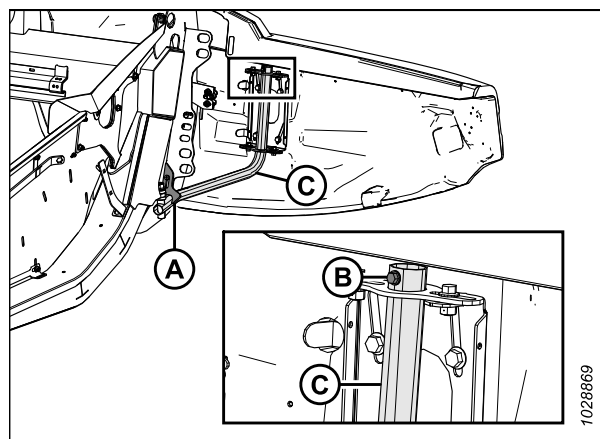


Figure 3.22: Left Header Endshield

### 3.2.4 Reel Drive Cover

The reel drive cover protects the reel drive components from dirt and debris.

#### Removing Reel Drive Cover

Remove the reel drive cover to service the reel drive components.



#### DANGER

To prevent injury or death from the unexpected start-up of the machine, always stop the engine and remove the key from the ignition before leaving the operator's seat for any reason.

## OPERATION

### DANGER

Ensure that all bystanders have cleared the area.

1. Start the engine.
2. Adjust the reel fully forward.
3. Lower the header fully.
4. Shut down the engine, and remove the key from the ignition.
5. Rotate spring latch (A) up and over the back plate.

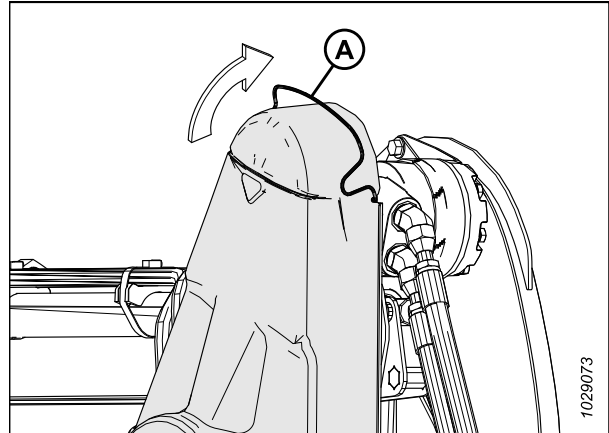


Figure 3.23: Upper Drive Cover

6. Unclip upper cover (A) from the lower cover at locations (B), and remove the upper cover. Keep the two clips engaged on the lower cover.

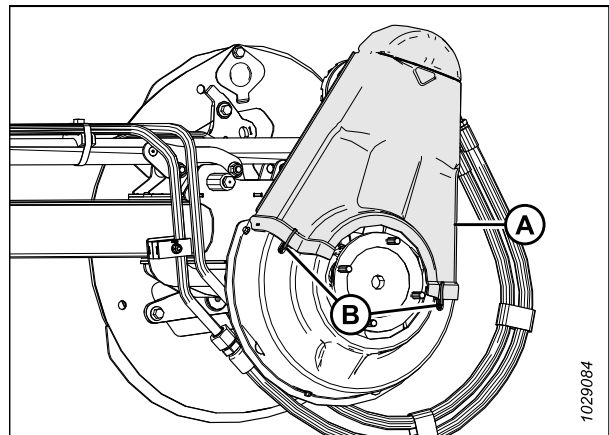


Figure 3.24: Upper Drive Cover

## OPERATION

7. If necessary, remove lower cover (B) by removing three bolts (A).

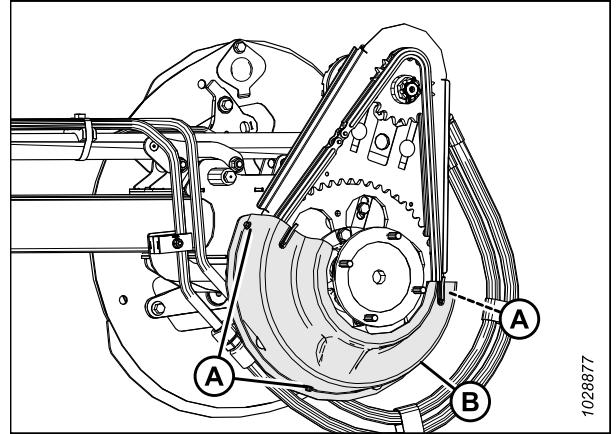


Figure 3.25: Lower Drive Cover

### *Installing Reel Drive Cover*

The reel drive cover protects the drive components from weather and debris. Do **NOT** operate the header without the reel drive cover.

### **DANGER**

To prevent injury or death from the unexpected start-up of the machine, always stop the engine and remove the key from the ignition before leaving the operator's seat for any reason.

1. Shut down the engine, and remove the key from the ignition.
2. Position lower drive cover (B) (if it was previously removed) onto the reel drive.
3. Secure the cover with three bolts (A).

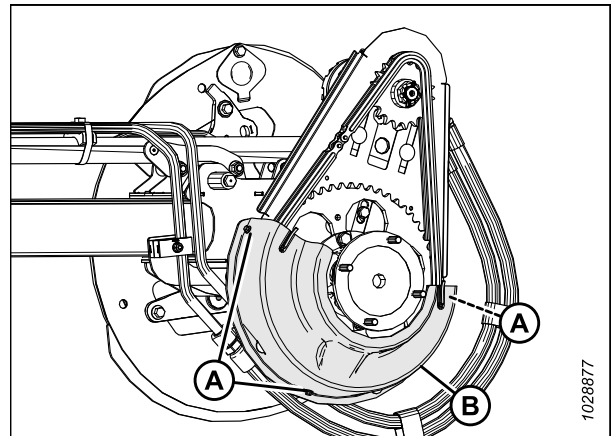


Figure 3.26: Lower Drive Cover

## OPERATION

4. Position upper cover (A) on the reel drive.
5. Secure the cover with two clips (B) on the lower cover.

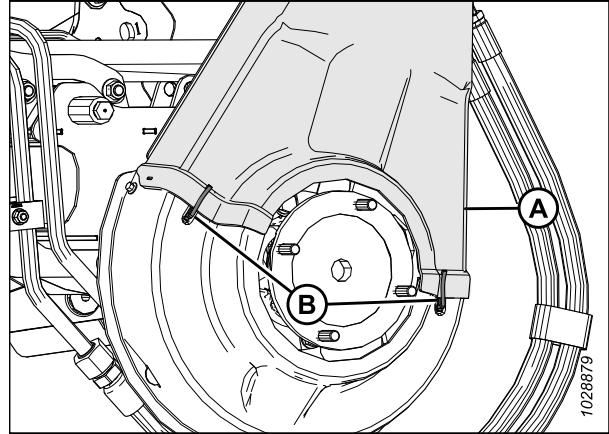


Figure 3.27: Upper Drive Cover

6. Rotate spring latch (A) down to secure the upper cover to the reel drive. Ensure that V-shaped loop (C) points down, and the spring end remains inserted into back plate hole (B) on both sides of the reel drive.

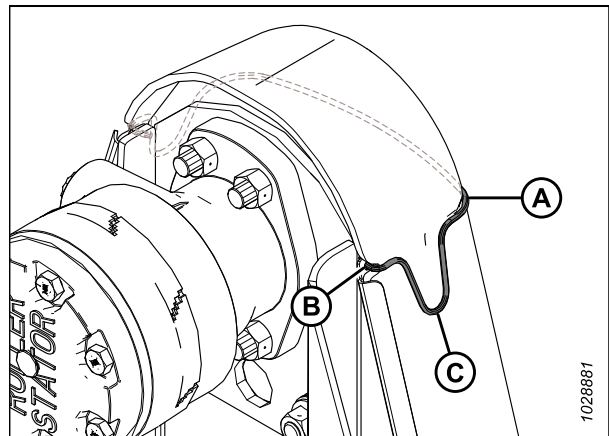


Figure 3.28: Reel Drive

### 3.2.5 Flex Linkage Cover

Plastic covers are attached to the header frame to protect the header wing balance mechanism from debris and weather.

#### *Removing Inboard Flex Linkage Covers*

Removing the flex linkage covers allows you to access the header's wing balance mechanism and hydraulic lines.

#### **DANGER**

To prevent injury or death from the unexpected start-up of the machine, always stop the engine and remove the key from the ignition before leaving the operator's seat for any reason.

#### **DANGER**

Ensure that all bystanders have cleared the area.

1. Start the engine.
2. Lower the header fully.
3. Shut down the engine, and remove the key from the ignition.



## OPERATION

4. Remove hair pin (A) and lynch pin (B) securing flex linkage cover (C) to the backtube.
5. Slide flex linkage cover (C) inboard, then lift it upward and remove it.

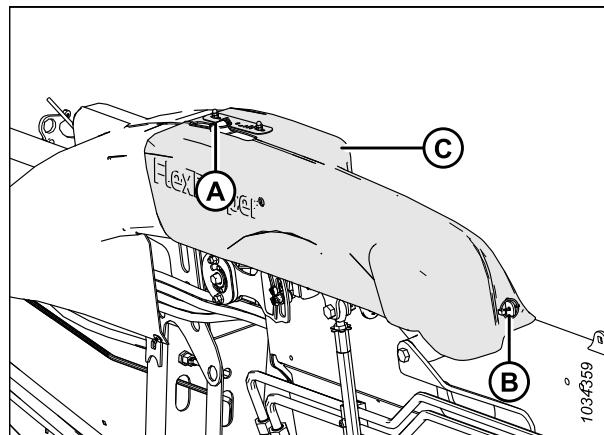


Figure 3.29: Inboard Flex Linkage Cover – Left Side

### *Installing Inboard Flex Linkage Covers*

The inboard flex linkage covers protect the header wing balance mechanism from debris and weather. They are secured to the header with pins.

#### **DANGER**

**To prevent bodily injury or death from the unexpected start-up of the machine, always stop the engine and remove the key from the ignition before leaving the operator's seat for any reason.**

1. Shut down the engine, and remove the key from the ignition.
2. Lower flex linkage cover (A) over the linkage. Ensure that slots (B) line up with tabs (C) and (D).
3. Slide the flex linkage cover outboard so that tab (D) extends beyond the slot.

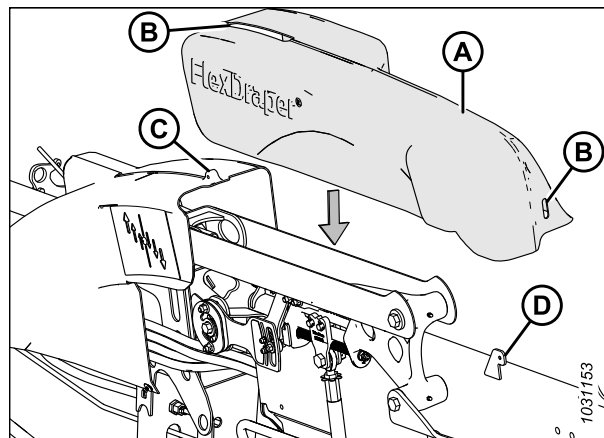


Figure 3.30: Inboard Flex Linkage Cover – Left Side

## OPERATION

- Secure flex linkage cover (C) with hair pin (A) and lynch pin (B).

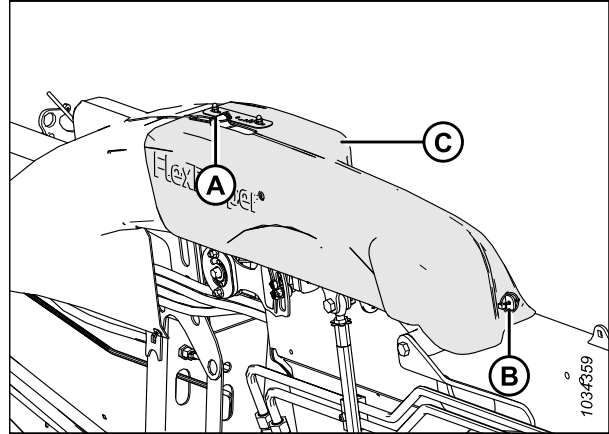


Figure 3.31: Inboard Flex Linkage Cover – Left Side

### Removing Outboard Flex Linkage Covers

Remove the flex linkage covers to access the header wing balance mechanism or the hydraulic lines.

#### DANGER

To prevent injury or death from the unexpected start-up of the machine, always stop the engine and remove the key from the ignition before leaving the operator's seat for any reason.

#### DANGER

Ensure that all bystanders have cleared the area.

- Lower the header fully.
- Shut down the engine, and remove the key from the ignition.
- FD245 and FD250 headers:** Remove screws (A) and the nuts (not shown) securing middle linkage cover (B) to the bracket (not shown).
- FD245 and FD250 headers:** Remove pin (C). Remove the cover by lifting it up and over the frame protrusions.

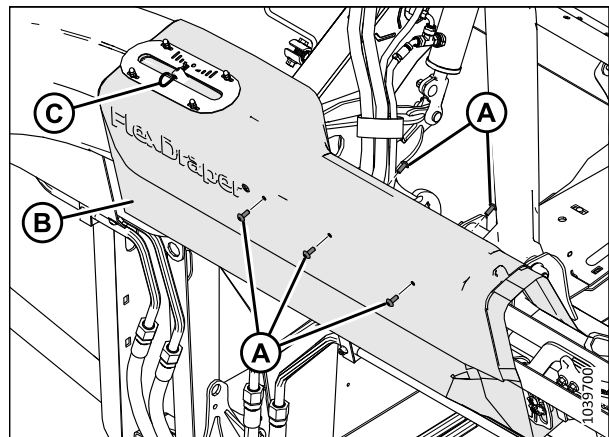


Figure 3.32: Middle Linkage Cover – FD245 and FD250 Headers Only

## OPERATION

5. Remove the linkage cover as follows:
  - a. Remove screw (A). The nut is integrated into the hydraulic line clamp.
  - b. Remove screw (B) and nut (not shown).

**NOTE:**

The Nyloc nut fits into a hex shape spot in the hydraulic line clamp, but it is removable.

- c. Remove screw (C) and hex nut.
- d. Lift the cover away from the wing lock handle.

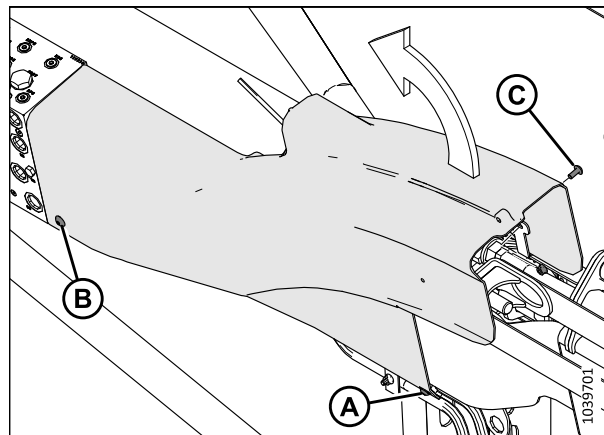


Figure 3.33: Outboard Linkage Cover

### *Installing Outboard Flex Linkage Covers*

Flex linkage covers protect the header wing balance mechanism from debris and weather.



## **DANGER**

To prevent bodily injury or death from the unexpected start-up of the machine, always stop the engine and remove the key from the ignition before leaving the operator's seat for any reason.

1. Shut down the engine, and remove the key from the ignition.
2. Position the left outboard linkage cover so that hole (A) goes over the wing lock.

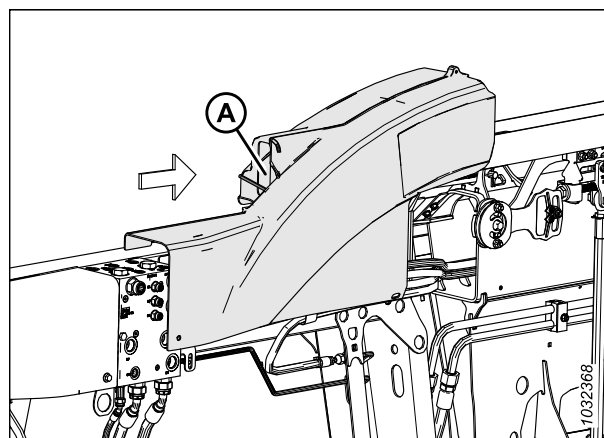


Figure 3.34: Left Linkage Cover – Rear of Header

## OPERATION

3. Seat the notch in the cover behind bracket (A) on the backtube, and line up the end so that it is flush with manifold (B).

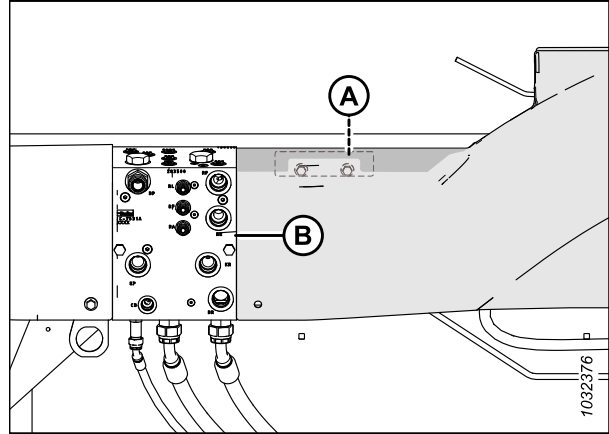


Figure 3.35: Left Linkage Cover – Rear of Header

4. Secure the outboard linkage cover as follows:
  - a. Install screw (A) and nyloc nut (B). The nut fits into a hex shape indent in the hydraulic line clamp.
  - b. Install screw (C). The nut is integrated into the bracket.
  - c. Install screw (D) and hex nut (E) to secure the front of the cover to the bracket.

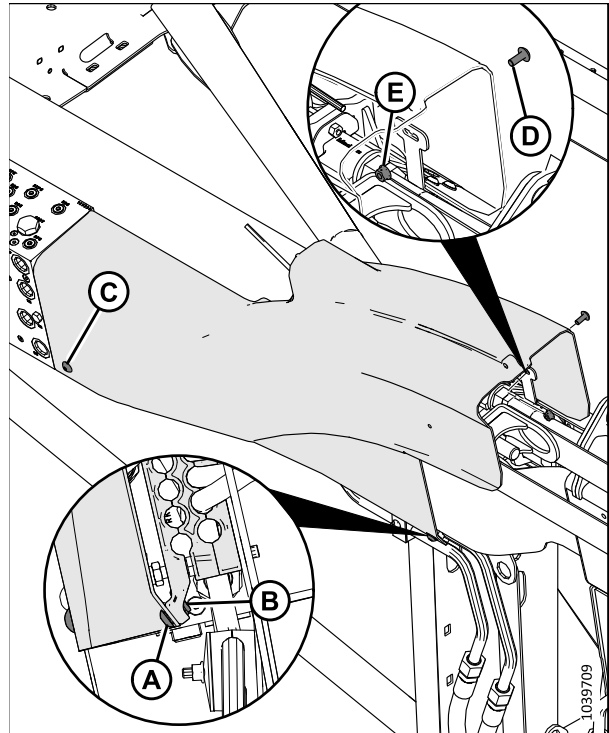


Figure 3.36: Outboard Linkage Cover – Rear of Header

## OPERATION

5. **FD245 and FD250 headers:** Place middle linkage cover (B) over flex linkage bracket and outboard linkage cover.
6. **FD245 and FD250 headers:** Install screws (A) and the nuts (not shown) securing middle linkage cover (B) to the bracket.
7. **FD245 and FD250 headers:** Install pin (C) through hole in the tab that protrudes through the flex indicator.

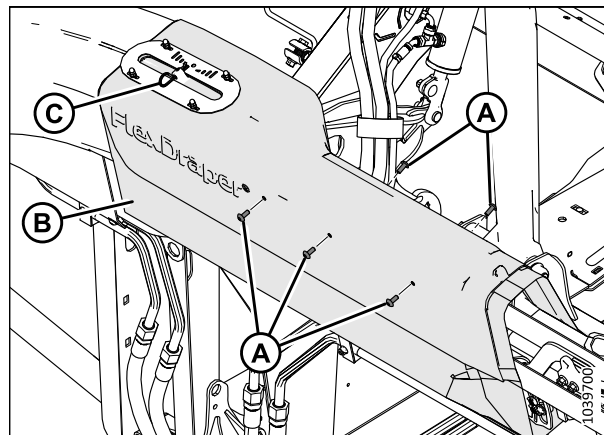


Figure 3.37: Middle Linkage Cover – FD245 and FD250 Headers Only

### 3.2.6 Daily Start-Up Check

Perform these checks daily before attempting to operate the machine.

#### CAUTION

- Clear the area of bystanders. Keep children away from machinery. Walk around the machine to be sure no one is under, on, or close to it.
- Wear close-fitting clothing and protective shoes equipped with slip-resistant soles.
- Remove potentially hazardous objects from the machine and from the surrounding area.
- Carry with you any protective clothing and personal safety devices that could be necessary through the day. Do NOT take chances. Personal safety devices that may be needed include a hard hat, protective glasses or goggles, heavy gloves, a respirator or filter mask, or wet weather gear.
- Protect against noise. Wear a suitable hearing protection device such as ear muffs or ear plugs to protect against objectionable or uncomfortably loud noises.

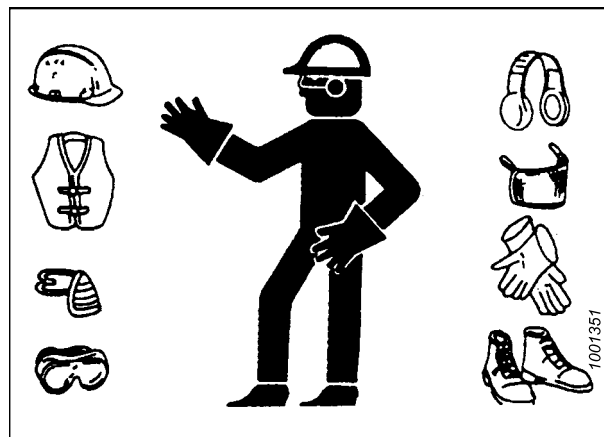


Figure 3.38: Safety Devices

Perform the following checks before starting the machine:

1. Inspect the machine for leaks and for any parts that are missing, damaged, or nonfunctional.

#### **IMPORTANT:**

Use the proper procedure when searching for pressurized fluid leaks. For instructions, refer to [4.2.5 Checking Hydraulic Hoses and Lines, page 572](#).

2. Clean all of the lights and the reflectors on the machine.
3. Perform all daily maintenance tasks. For instructions, refer to [4.2.1 Maintenance Schedule/Record, page 568](#).

### 3.3 Break-in Period

During the first 50 hours of operation, certain systems on the header will require extra attention. Follow this procedure to ensure the service life of the header.

**NOTE:**

Until you become familiar with the sound and feel of your new header, be extra attentive.

 **DANGER**

Before investigating an unusual sound or attempting to correct a problem, shut off the engine and remove the key from the ignition.

 **DANGER**

Ensure that all bystanders have cleared the area.

After attaching the header to the combine for the first time, follow these steps:

1. Slowly run the reels, the drapers, and the knives for five minutes. **FROM THE OPERATOR'S SEAT**, watch and listen for any interference.

**NOTE:**

The reels and the side drapers will not operate until hydraulic oil fills the lines.

2. Refer to [4.2.2 Break-in Inspection, page 570](#) and perform all the specified tasks.

## 3.4 Shutting Down Combine

Before leaving the operator's seat for any reason, shut down the combine.

### DANGER

To prevent injury or death from the unexpected start-up of the machine, always stop the engine and remove the key from the ignition before leaving the operator's seat for any reason.

### DANGER

Ensure that all bystanders have cleared the area.

To shut down the combine, do the following:

1. Park the combine on level ground.
2. Lower the header fully.
3. Place all of the controls in NEUTRAL or PARK.
4. Disengage the header drive.
5. Lower and fully retract the reel.
6. Shut down the engine, and remove the key from the ignition.
7. Wait for the machine to stop moving.

## 3.5 Cab Controls

The header is controlled from the combine cab.

### DANGER

Ensure that all bystanders have cleared the area.

For instructions, refer to your combine operator's manual to identify the following in-cab controls:

- Header engage/disengage control
- Header height
- Header angle
- Ground speed
- Reel speed
- Reel height
- Reel fore-aft position

### 3.5.1 CLAAS Series Cab Controls

Mapping controls on the console and joystick allows for smooth combine operation.

#### *Selecting the Default Function for the Multifunction Lever Toggle Switch (with CLAAS Integration Kit)*

The default function for the multifunction lever toggle switch is selectable. For example, when cutting on the ground, the default function can be set so that the multifunction lever's toggle switch activates the pitch control cylinder. Likewise, when cutting off the ground, the default function can be changed so that the toggle switch controls the contour wheels.

### DANGER

Ensure that all bystanders have cleared the area.

#### NOTE:

Changes may have been made to the combine controls or the display since this document was published. For the most up-to-date information, refer to the combine operator's manual.

#### *To select pitch control as the default toggle function:*

1. **If the combine is equipped with a standard lever:**  
While pressing the REEL FORE button, push toggle (A) up.  
Hold the toggle and the button for 30 seconds.

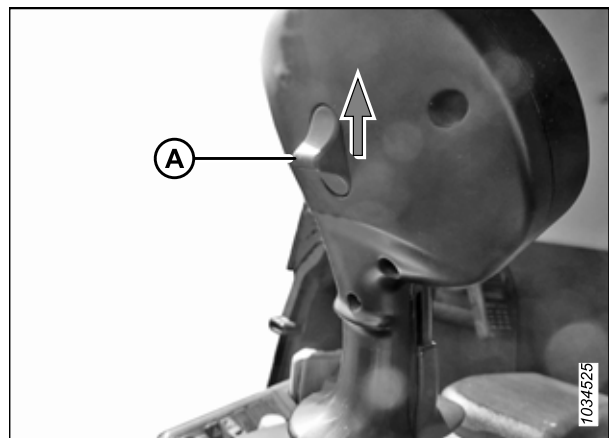


Figure 3.39: Standard Lever



## OPERATION

2. **If the combine is equipped with a CMOTION multifunction lever:** While pressing the REEL FORE button, pull multifunction lever toggle switch (A) toward you. Hold the toggle and the button for 30 seconds.

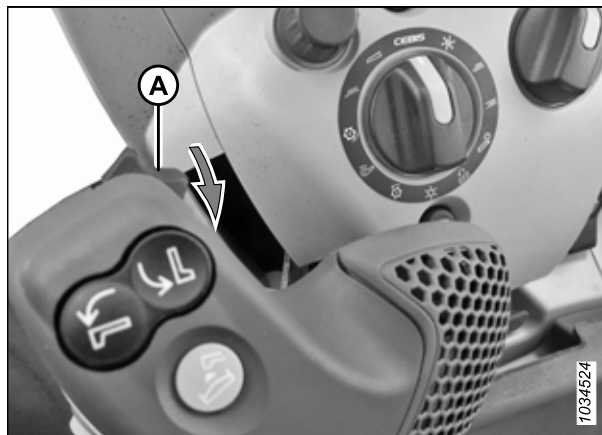


Figure 3.40: CMOTION Lever

*To select contour wheel as the default toggle function:*

3. **If the combine is equipped with a standard lever:** While pressing the REEL AFT button, push toggle (A) up. Hold the toggle and the button for 30 seconds.

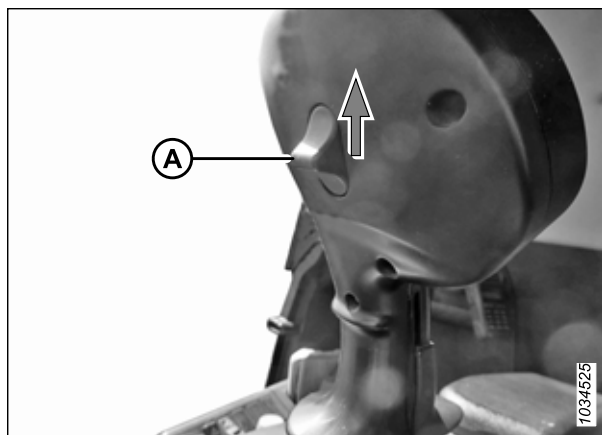


Figure 3.41: Standard Lever

4. **If the combine is equipped with a CMOTION multifunction lever:** While pressing the REEL AFT button, pull multifunction lever toggle switch (A) toward you. Hold the toggle and the button for 30 seconds.

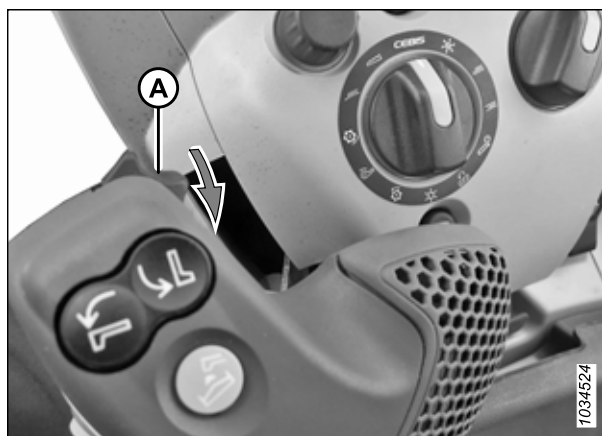


Figure 3.42: CMOTION Lever

## OPERATION

### Controlling Header Pitch Cylinder

When pitch control is selected as the default function, the pitch cylinder can be controlled with the toggle switch on the front of the multifunction lever.

When the kit is first installed, pitch cylinder control will be set as the default function. For instructions on toggling the default function between header pitch and contour wheels, refer to [Selecting the Default Function for the Multifunction Lever Toggle Switch \(with CLAAS Integration Kit\)](#), page 60.

#### If the combine is equipped with CMOTION multifunction lever (C):

- To extend the pitch control cylinder, push the toggle away from you (in the direction indicated by arrow [A]).
- To retract the pitch control cylinder, pull the toggle toward you (in the direction indicated by arrow [B]).

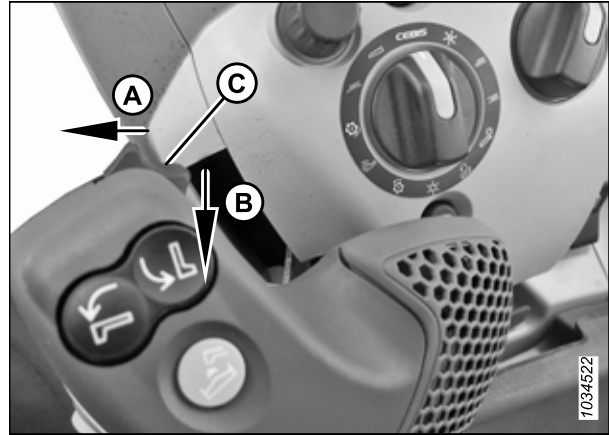


Figure 3.43: CMOTION Lever

#### If the combine is equipped with standard multifunction lever (C):

- To extend the pitch control cylinder, press multifunction lever toggle switch down (in the direction indicated by arrow [A]).
- To retract the pitch control cylinder, press multifunction lever toggle switch up (in the direction indicated by arrow [B]).

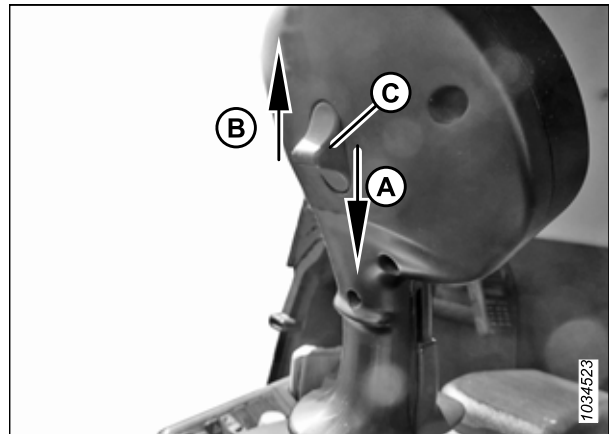


Figure 3.44: Standard Lever

### Controlling Draper Speed – CLAAS 600 and 700 Series

The speed of the header's drapers can be controlled through the appropriate selection in the SIDE DRAPER SPEED menu in the combine's CEBIS.

#### **DANGER**

Ensure that all bystanders have cleared the area.

#### **NOTE:**

Changes may have been made to the combine controls or the display since this document was published. For the most up-to-date information, refer to the combine operator's manual.

1. Engage the header.

## OPERATION

2. Ensure that selection dial (A) is in CEBIS position (B).

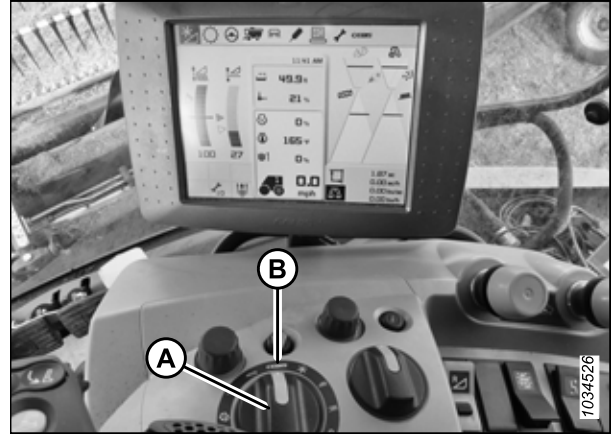


Figure 3.45: CEBIS Dial Position for Draper Speed Control

3. Rotate hot key dial (A) one notch clockwise to show DRAPER SPEED icons (B).

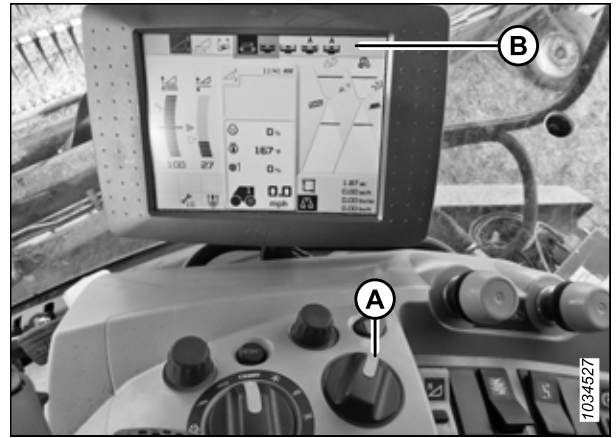


Figure 3.46: Hot Key Position for Draper Speed Control

4. Use left menu selection switch (A) to scroll over to SIDE DRAPER SPEED icon (B).

**NOTE:**

The header will have to be running for the icon to be active.

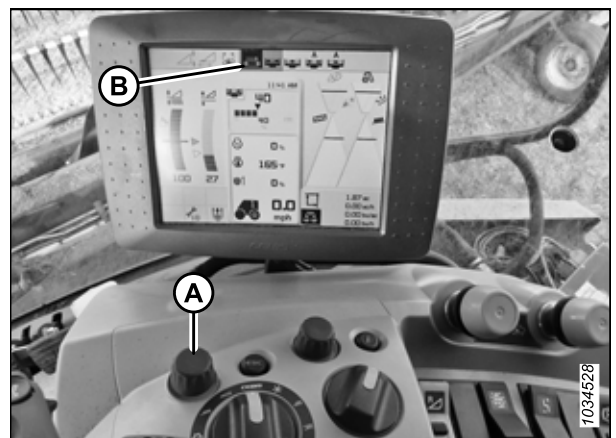


Figure 3.47: Draper Speed Icons

## OPERATION

5. Select DRAPER SPEED icon (B) by using right menu selection switch (A).

**NOTE:**

You will not see the other four icons on the right side of the menu bar.

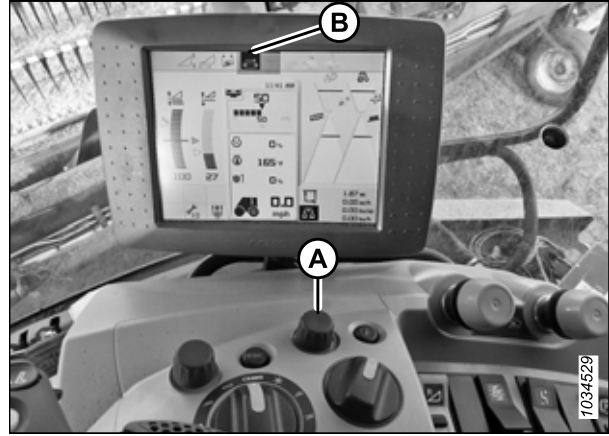


Figure 3.48: Draper Speed Icon on Older CLAAS Machines

6. Using right switch (A), adjust the side draper speed as desired. Allow up to five seconds for the speed to change.

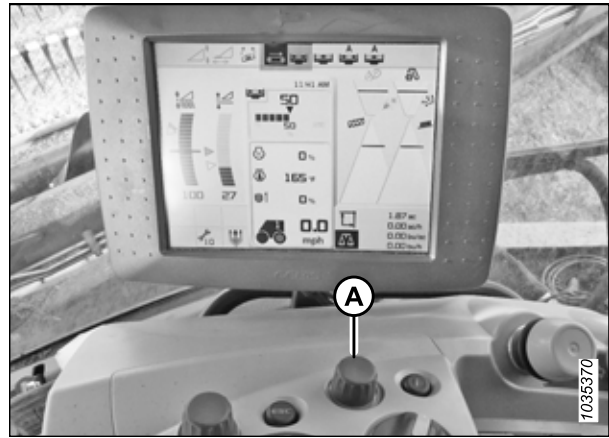


Figure 3.49: Draper Speed Icon

### *Controlling Draper Speed – CLAAS 5000, 6000, 7000, and 8000 Series*

The draper speed can be set using the CONVIO menu in the CEBIS. The header must be running before you can change the draper speed.

**! DANGER**

Ensure that all bystanders have cleared the area.

**NOTE:**

Changes may have been made to the combine controls or the display since this document was published. For the most up-to-date information, refer to the combine operator's manual.

1. Engage the header.

## OPERATION

- Under HEADER menu icon (A), scroll to CONVIO settings (B) and select draper speed gauge (C).

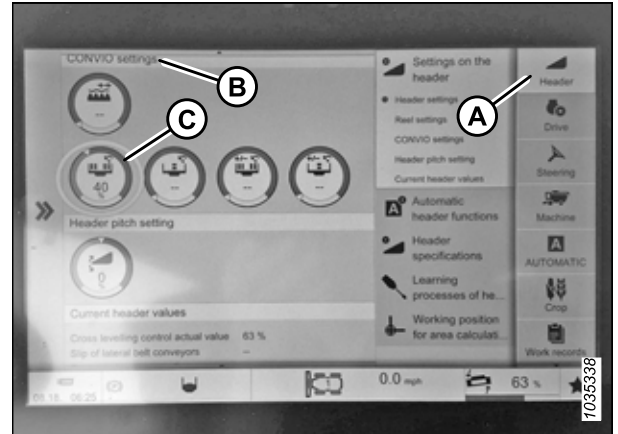


Figure 3.50: Draper Speed Selection

- Adjust the draper speed by tapping + icon (A) or – icon (B).
- Press check mark (C) to save your changes.



Figure 3.51: Draper Speed Selection

### Viewing Header Hours

The hours that the header has been running can be retrieved through the CEBIS terminal.

### DANGER

Ensure that all bystanders have cleared the area.

### NOTE:

Changes may have been made to the combine controls or the display since this document was published. For the most up-to-date information, refer to the combine operator's manual.

## OPERATION

1. Ensure that selection dial (A) is in CEBIS position (B).
2. Using left menu selection switch (C), scroll to WRENCH/MAINTENANCE icon (D). Press the left menu selection switch.

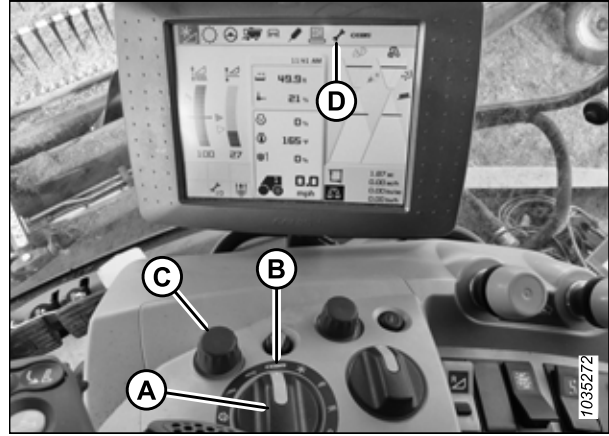


Figure 3.52: CEBIS Dial Position

The header's operating hours and maintenance information will appear on the screen.

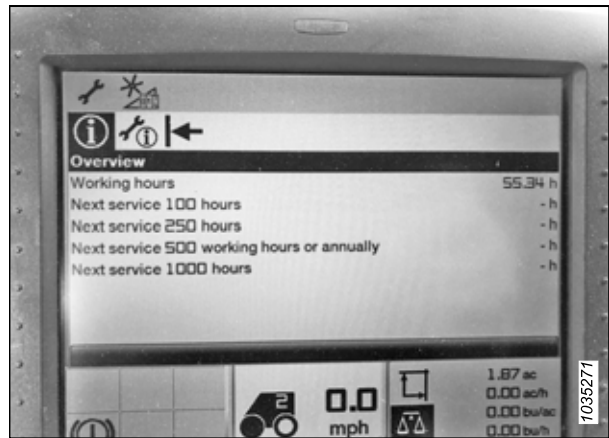


Figure 3.53: Header Hours

### 3.5.2 John Deere X9 Series Cab Controls

Mapping controls on the console and joystick allows for smooth combine operation.

#### *Assigning Ground Speed Lever Buttons – John Deere X9 Series*

The function of the buttons on the ground speed lever (GSL) in the cab of the combine can be customized to suit the Operator's preferences.

#### **⚠ DANGER**

Ensure that all bystanders have cleared the area.

#### **NOTE:**

Changes may have been made to the combine controls or the display since this document was published. For the most up-to-date information, refer to the combine operator's manual.



## OPERATION

1. Start the engine.
2. Press HEADER button (A) on the panel below the display. The HEADER page opens.



Figure 3.54: CommandCenter™ Display

3. Press multifunction lock button (A) until the light turns off. The CONTROLS SETUP page appears.



Figure 3.55: John Deere X9 Console

4. On ground speed lever (GSL) (A), select a function button (A, B, C, or D) to configure.

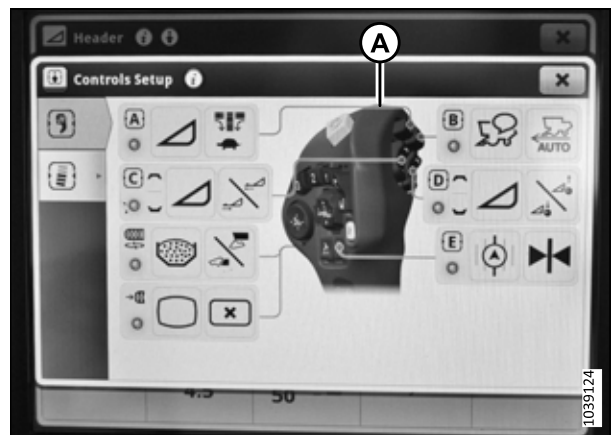


Figure 3.56: John Deere X9 Display – Controls Setup

## OPERATION

**NOTE:**

There is a known issue with the John Deere display that can cause problems when certain buttons are mapped together on the GSL or the arm console. The following matrix specifies which combinations can be mapped together.

	Turtle Mapping	A	B	E	Roller	3	4
Tilt Mapping							
A			Yes	Yes	Yes	Yes	Yes
B		No		Yes	Yes	Yes	Yes
E		No	No		No	No	No
Roller		Yes	Yes	Yes		Yes	No
3		Yes	Yes	Yes	Yes		Yes
4		Yes	Yes	Yes	Yes	No	

5. On SELECT FUNCTION window (A), press the UP or DOWN arrows to find the desired function.
6. Select the function to assign to the selected button.
7. Select the X in the top right corner to exit the CONTROLS SETUP page.



Figure 3.57: John Deere X9 Display – Controls Setup

### Assigning Console Buttons – John Deere X9 Series

The function of the buttons on the console in the cab of the combine can be customized to suit the preferences of the Operator.

** DANGER**

Ensure that all bystanders have cleared the area.

**NOTE:**

Changes may have been made to the combine controls or the display since this document was published. For the most up-to-date information, refer to the combine operator’s manual.



## OPERATION

1. Start the engine.
2. Press HEADER button (A) on the panel below the display. The HEADER page opens.



Figure 3.58: CommandCenter™ Display

3. Press CONSOLE LOCK button (A) until the light turns off. The CONTROLS SETUP page appears.



Figure 3.59: John Deere X9 – Console

4. Press the function button on console (A) that you want to program or modify.

**NOTE:**

Only button 2 is a rocker switch.

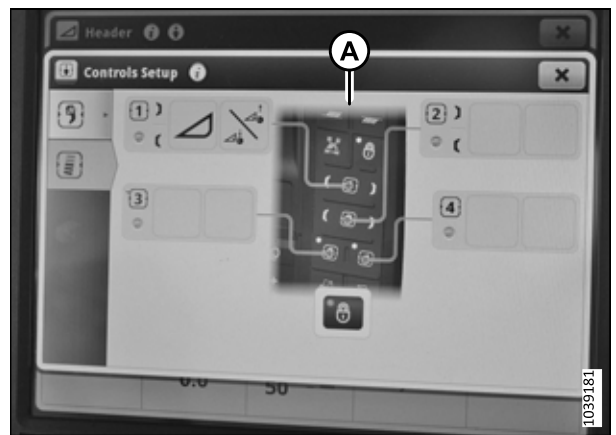


Figure 3.60: John Deere X9 Display – Controls Setup

## OPERATION

5. On SELECT FUNCTION window (A), press the UP or DOWN arrow to find the desired function.
6. Select the function to assign it to the selected button.
7. Select the X in the top right corner to exit the CONTROLS SETUP page.

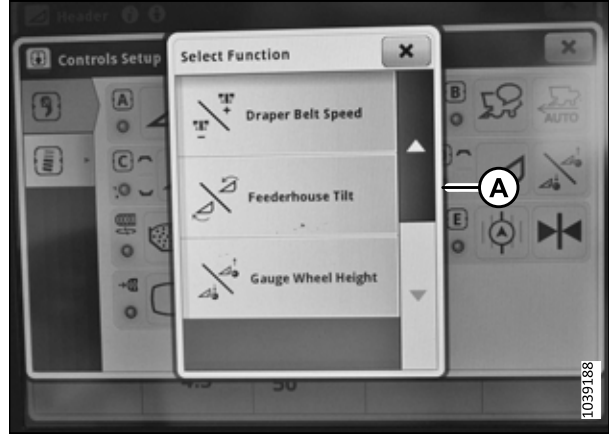


Figure 3.61: John Deere X9 Display – Controls Setup

### *Using Wing Level Function as Tilt Toggle – John Deere X9 Series*

Using the function for wing level, you can toggle between controlling the reel fore/aft and controlling the header tilt cylinder with the combine ground speed lever (GSL).

### **DANGER**

Ensure that all bystanders have cleared the area.

#### **NOTE:**

Changes may have been made to the combine controls or the display since this document was published. For the most up-to-date information, refer to the combine operator's manual.

1. Start the engine.
2. Press MULTIFUNCTION LOCK button (A). The CONTROLS SETUP page appears.



Figure 3.62: John Deere X9 – Console

## OPERATION

3. Examine which control on the ground speed lever is mapped to WING LEVEL icon (A).

### NOTE:

In this illustration, the wing level is mapped to switch A.

Mapping the wing level icon to the GSL will allow the user to control the reel fore/aft or control the header tilt cylinder with the press of a button.

When the mapped button is pressed, the header will interpret moving the reel fore/aft as moving the tilt cylinder fore/aft. After the user is finished adjusting the tilt cylinder, they can press the mapped button once again to control the reel fore/aft.



Figure 3.63: John Deere X9 Display – Controls Setup

### Mapping Draper Speed Controls on Ground Speed Lever – John Deere X9 Series

Draper speed controls can be mapped to the ground speed lever (GSL) or buttons on the command arm.

### DANGER

Ensure that all bystanders have cleared the area.

### NOTE:

Changes may have been made to the combine controls or the display since this document was published. For the most up-to-date information, refer to the combine operator's manual.

1. Start the engine.
2. Press MULTIFUNCTION LOCK button (A). The CONTROLS SETUP page appears.



Figure 3.64: John Deere X9 – Console

## OPERATION

3. Examine which control on the GSL is mapped to TURTLE MODE icon (A).

**NOTE:**

In this illustration, turtle mode is mapped to switch A.

Turtle mode allows you to switch to a slower draper speed at the press of a button. The draper speed in turtle mode can be adjusted during normal operation.

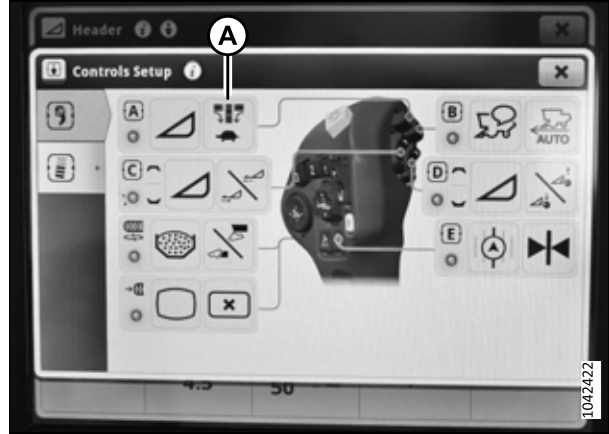


Figure 3.65: John Deere X9 Display – Controls Setup

4. Examine which control on the GSL is mapped to DRAPER SPEED CONTROL icon (A).

**NOTE:**

In this illustration, the draper speed control is mapped to switch D.

Mapping the draper speed control to the GSL will allow you to adjust the draper speed at the press of a button. The draper speed can be adjusted during normal operation.



Figure 3.66: John Deere X9 Display – Controls Setup

### *Locking/Unlocking Double Tap Tilt Function – John Deere X9 Series*

With the double tap tilt function unlocked, operating the header tilt is performed the same way as in previous versions of John Deere's integration software.

**NOTE:**

Changes may have been made to the combine controls or the display since this document was published. For the most up-to-date information, refer to the combine operator's manual.

## OPERATION

If you wish to use the double tap method of controlling the header tilt, you can lock/unlock the function by holding REEL FORE button (A) on the ground speed lever (GSL) for 30 seconds.

### NOTE:

There will be no indicator to signify that the double tap function has been locked/unlocked.



Figure 3.67: Reel Fore Button

### 3.6 Header Attachment/Detachment

This chapter includes instructions for configuring, attaching, and detaching the header.

Combine	Refer to
Case IH Models: 5/6/7088, 7/8010, 7/8/9120, 130, 140, 150, 230, 240, 250 Series Case IH Models: 21XX/23XX/25XX	<a href="#">3.6.1 Case IH Combines, page 74</a>
Challenger® 66/67/680B, 540C/560C Gleaner® A-Series Models: A66/76/86 Gleaner® R-Series & Super-Series Models: R65/75, R66/76, S67/77, S68/78/88, S96/97/98 Massey Ferguson® 9520/40/50, 9695/9795/9895	<a href="#">3.6.2 Challenger®, Gleaner®, and Massey Ferguson® Combines, page 83</a>
CLAAS/CAT-Lexion Models: 560/570/580/590R, 575/585/595R, 600 CLAAS Lexion 600 and 700 Series Models: 6X0 and 7X0 CLAAS Lexion 5/6/7/8000 Series and Models: 5X00, 6X00, 7X00, 8X00 CLAAS Lexion TRION Series	<a href="#">3.6.3 CLAAS Combines, page 91</a>
IDEAL™ (Massey Ferguson®, Fendt®, and Valtra®) Models: 7, 8, 9, 10	<a href="#">3.6.4 IDEAL™ Series Combines, page 105</a>
John Deere T, 60/70 and S-Series Models: T5X0, T6X0, 9X60, 9X70, S6X0, S7X0 John Deere X9 Series	<a href="#">3.6.5 John Deere Combines, page 111</a>
New Holland CR Models: CR 9X0, 90X0, X090, X080, X.90, X.80 New Holland CX Models: CX 8X0, 80X0, 8.X0 New Holland CH Model: CH7.70	<a href="#">3.6.6 New Holland Combines, page 123</a>
Rostselmash 161, T500, and TORUM 785	<a href="#">3.6.7 Rostselmash Combines, page 133</a>

**NOTE:**

Ensure that the applicable functions (automatic header height control [AHHC], draper header option, hydraulic center-link option, hydraulic reel drive) are enabled on the combine and the combine computer. Failure to do so may result in improper header operation.

#### 3.6.1 Case IH Combines

To attach the header to or detach it from a Case IH combine, follow the relevant procedure in this section.

##### *Attaching Header to Case IH Combine*

The header will need to be physically connected to the combine’s feeder house, and the electrical and hydraulic connections completed.



To prevent injury or death from the unexpected start-up of the machine, always stop the engine and remove the key from the ignition before leaving the operator’s seat for any reason.



Ensure that all bystanders have cleared the area.

## OPERATION

### IMPORTANT:

If the combine is **NOT** equipped with a rock trap, feeder house faceplate (A) **MUST** be in mid-position (B). For instructions on adjusting the faceplate, refer to the combine operator's manual.

### NOTE:

A rock trap prevents rocks or debris from entering the combine, and is located on the front of the combine and behind the feeder house.

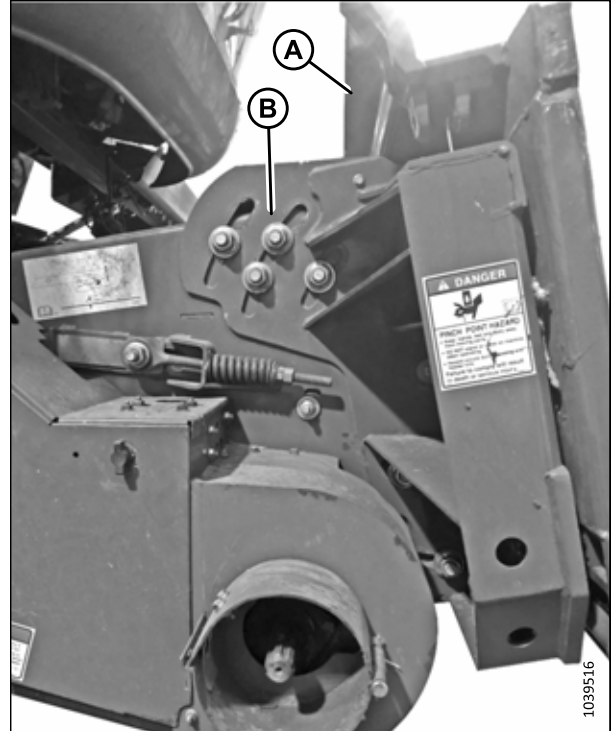


Figure 3.68: Faceplate Tilted to Mid-Position on Unspecified Combine

1. Shut down the engine, and remove the key from the ignition.
2. On the combine, ensure that lock handle (A) is positioned so hooks (B) can engage the float module.

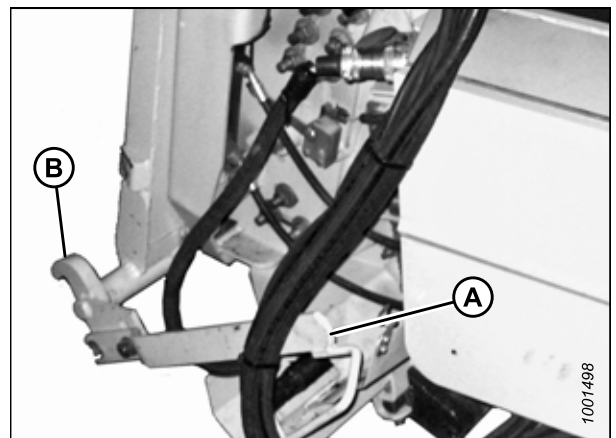


Figure 3.69: Feeder House Locks



## OPERATION

3. Slowly drive the combine up to the header until feeder house saddle (A) is directly under float module top cross member (B).
4. Raise the feeder house slightly to lift the header. Ensure that the feeder saddle is properly engaged in the float module's frame.
5. Shut down the engine, and remove the key from the ignition.

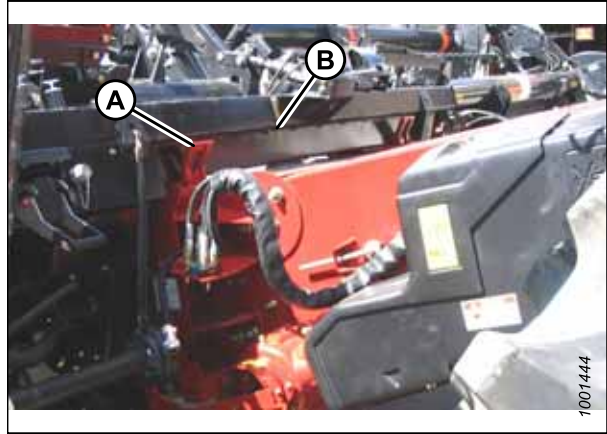


Figure 3.70: Combine and Float Module

6. On the left side of the feeder house, lift lever (A) on the float module and push handle (B) on the combine to engage locks (C) on both sides of the feeder house.
7. Push lever (A) down so that the slot in the lever locks the handle.
8. If lock (C) does not fully engage the pin on the float module, loosen bolts (D) and adjust the lock. Retighten the bolts.

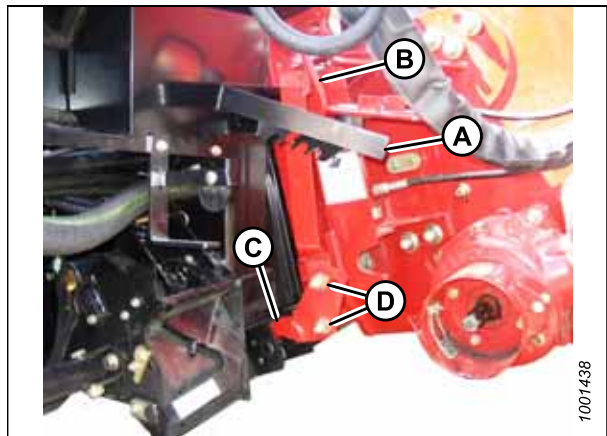
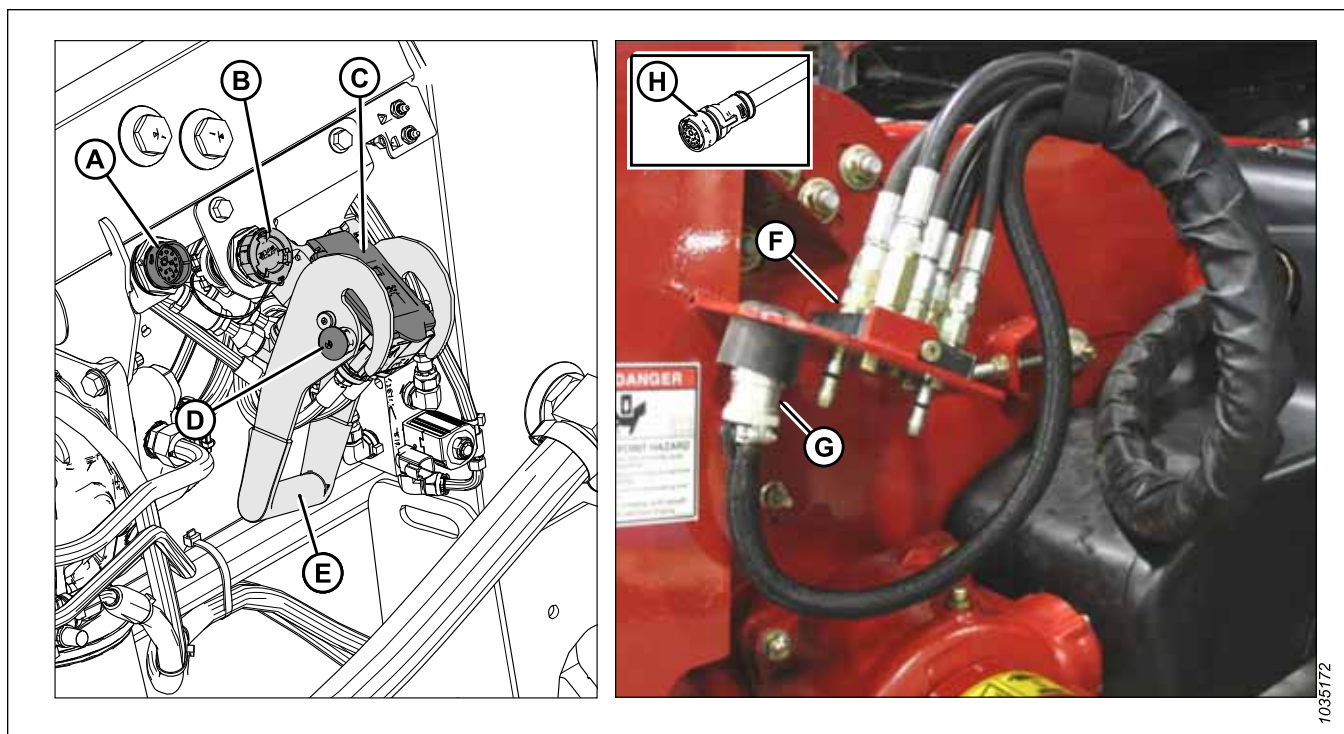


Figure 3.71: Combine and Float Module



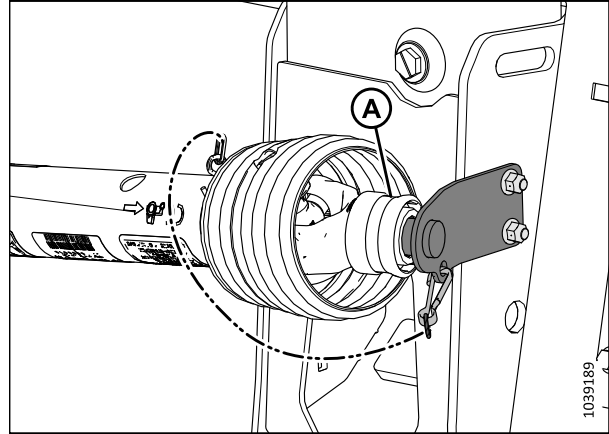


**Figure 3.72: Multicoupler and Electrical Connections**

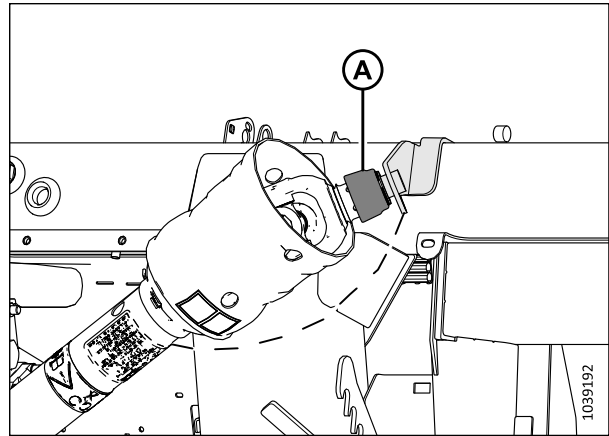
9. **If MacDon in-cab controls are installed:** Remove the cap from connector C81B (A).
10. Remove the cap from connector C72B (B).
11. Remove the cover from hydraulic receptacle (C). Clean the receptacle mating surfaces.
12. Push in lock button (D) and pull handle (E) to the fully open position.
13. Remove hydraulic quick coupler (F) from the storage plate on the combine. Clean the mating surface of the coupler.
14. Position coupler (F) onto float module receptacle (C), and push handle (E) to engage the pins into the receptacle.
15. Push handle (E) to the closed position until lock button (D) snaps out.
16. Remove combine connector (G) from its storage location on the combine and connect it to receptacle C72B (B). Turn the collar on the connector to lock it in place.
17. **If MacDon in-cab controls are installed:** Remove cab control kit connector C81A (H) from its storage location on the combine and connect it to C81B (A). Turn the collar on the connector to lock it in place.

## OPERATION

18. Pull driveline collar (A) back to release the driveline from the support bracket. Remove the driveline from the support bracket.

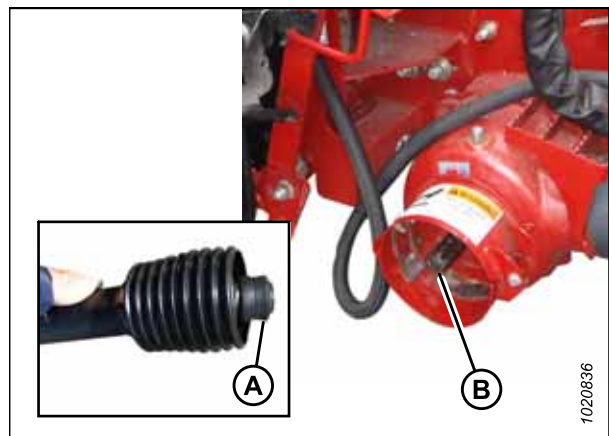


**Figure 3.73: Driveline in Storage Position – Driveline B7038 or B7039**



**Figure 3.74: Driveline in Storage Position – Sidehill/Hillside Driveline B7180, B7181, or B7326**

19. Pull back collar (A) on the end of the driveline. Push the driveline onto combine output shaft (B) until the collar locks.



**Figure 3.75: Combine Output Shaft**

## OPERATION

20. Proceed as follows:

- If the header is going to be used in the field now, disengage the float locks by pulling each float lock handle (A) away from the float module and into unlocked position (B).
- If the header is **NOT** going to be used in the field now, engage the float locks by pushing each float lock handle (A) toward the float module and into locked position (C).

### NOTE:

The illustration shows the float lock handle on the right side of the header. The float lock handle on the left side of the header is the opposite.

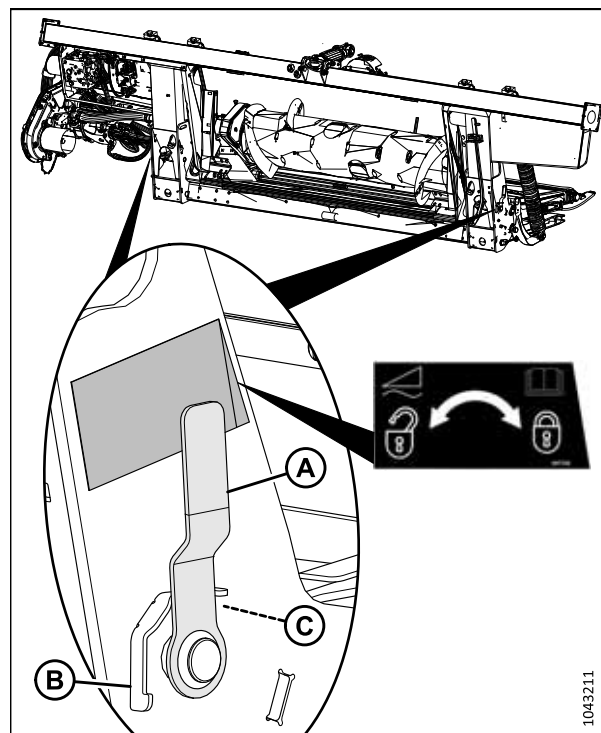


Figure 3.76: Float Lock Handle

### Detaching Header from Case IH Combine

The header will need to be physically disconnected from the combine, and the hydraulic and electrical connections will need to be removed.

### DANGER

To prevent bodily injury or death from the unexpected start-up or fall of a raised machine, always stop the engine, remove the key, and engage the safety props before going under the header for any reason.

### DANGER

Ensure that all bystanders have cleared the area.

1. Park the combine on a level surface.
2. Position the header slightly above the ground.
3. Shut down the engine, and remove the key from the ignition.

### IMPORTANT:

If transport wheels are installed, set the wheels to the storage or uppermost working position. If the wheels are not in position, the header may tilt forward and make reattachment difficult. For instructions, refer to [Adjusting EasyMove™ Transport Wheels, page 191](#).

### IMPORTANT:

If stabilizer wheels are installed, set the wheels to the storage or uppermost working position. If the wheels are not in position, the header may tilt forward and make reattachment difficult. For instructions, refer to [Adjusting Stabilizer Wheels, page 190](#).

## OPERATION

- Engage the float locks by pulling each float lock handle (A) away from the float module and setting it in locked position (B).

**NOTE:**

The illustration shows the float lock handle on the right side of the header. The float lock handle on the left side of the header is the opposite.

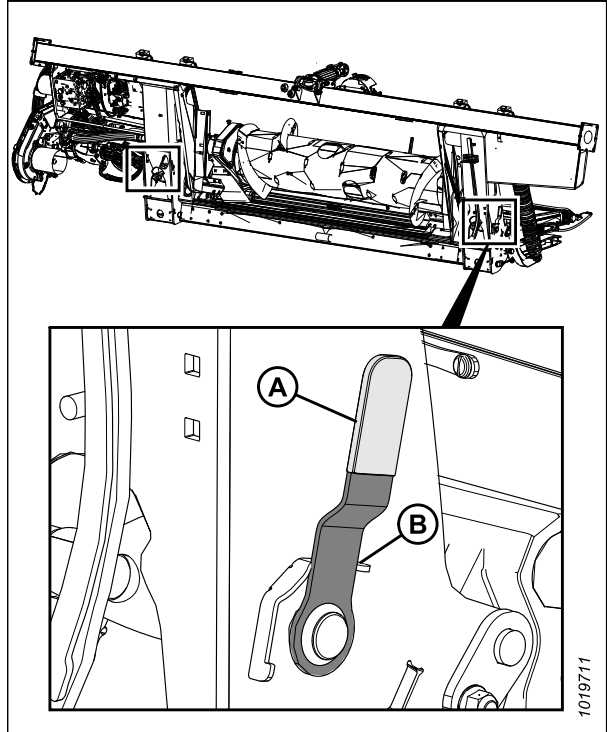


Figure 3.77: Float Lock Handle

- Push back collar (A) on the end of the driveline and pull the driveline out of combine output shaft (B) until the collar disengages.

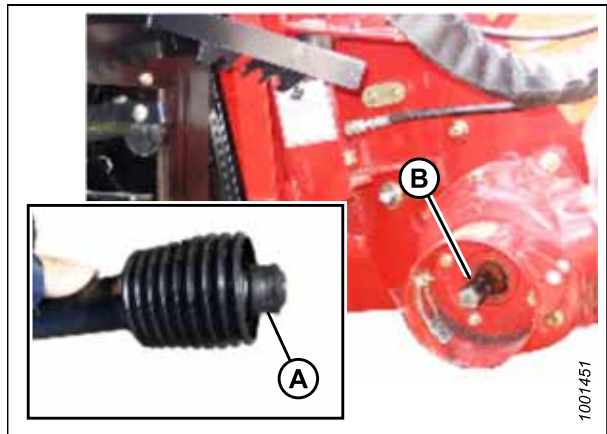


Figure 3.78: Driveline

## OPERATION

6. Store the driveline on driveline support bracket (B) by pulling back collar (A) on the driveline and fitting it onto support bracket (B). Release the collar so it locks into place on the support bracket.

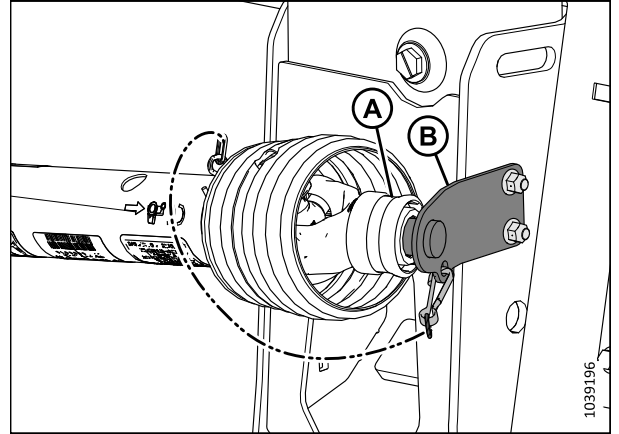


Figure 3.79: Driveline in Storage Position – Driveline B7038 or B7039

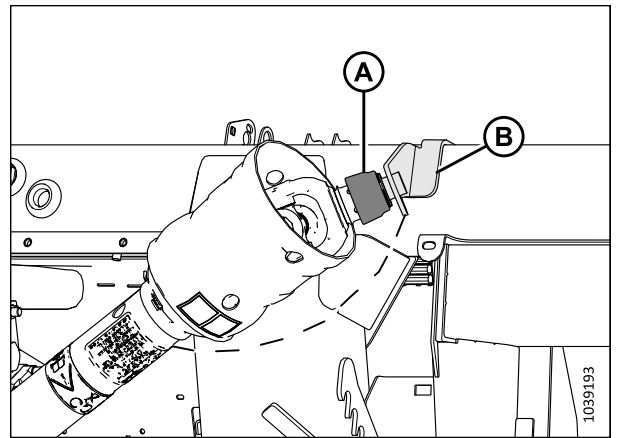


Figure 3.80: Driveline in Storage Position – Sidehill/Hillside Driveline B7180, B7181, or B7326

7. Remove electrical connector (A) and replace cover (B).
8. If MacDon in-cab controls are installed, turn the collar on connector C81A to disconnect it from C81B.
9. Push in lock button (C) and pull handle (D) to release multicoupler (E).

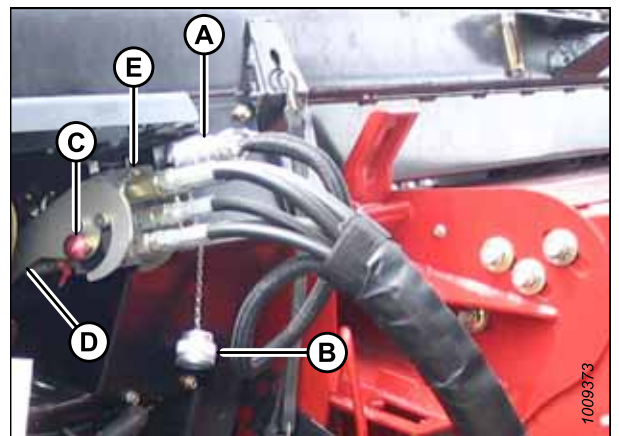


Figure 3.81: Multicoupler

## OPERATION

10. Position multicoupler (A) onto storage plate (B) on the combine.
11. Place electrical connector (C) in storage cup (D).
12. If you disconnected MacDon cab control connector C81A from C81B, move the connector to its storage location on the combine.

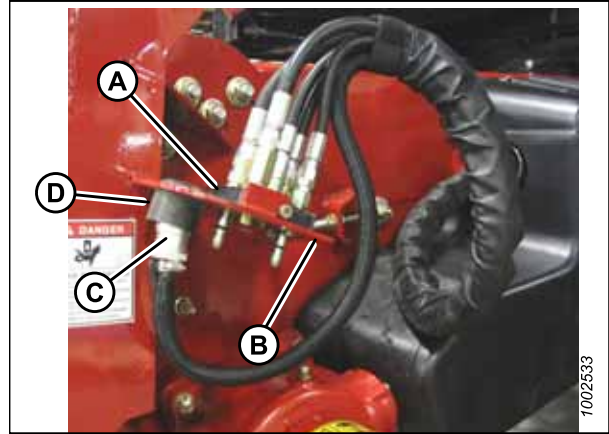


Figure 3.82: Multicoupler Storage

13. Push handle (A) on the float module receptacle to the closed position until lock button (B) snaps out. Close the cover.

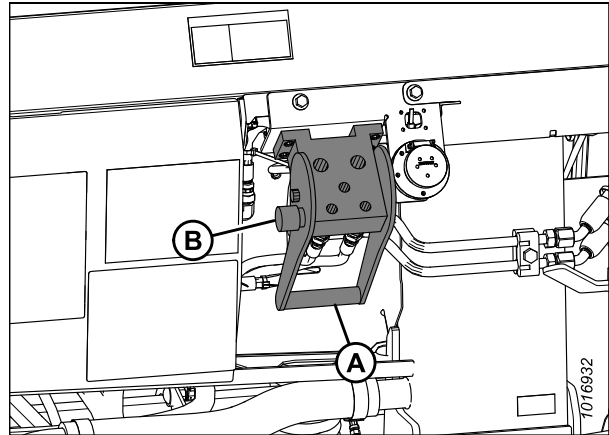


Figure 3.83: Float Module Receptacle

14. Lift lever (A) and pull, and lower handle (B) to disengage feeder house/float module lock (C).
15. Lower the feeder house until it disengages the float module support.
16. Back the combine away slowly from the float module.

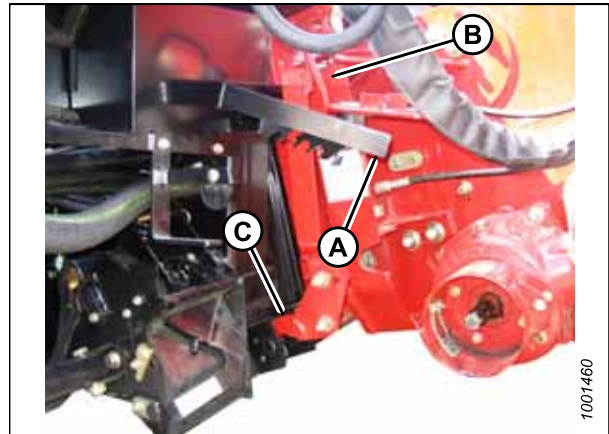


Figure 3.84: Feeder House Locks



### 3.6.2 Challenger®, Gleaner®, and Massey Ferguson® Combines

To attach the header to or detach it from a Challenger®, Gleaner®, or Massey Ferguson® combine, follow the relevant procedure in this section.

#### *Attaching Header to Challenger®, Gleaner®, or Massey Ferguson® Combine*

The header will need to be physically connected to the combine's feeder house, and the electrical and hydraulic connections completed.

**NOTE:**

The float module is equipped with a multicoupler that connects to the combine. If the combine is equipped with individual connectors, a multicoupler kit (single-point connector) must be installed. Refer to Table 3.1, page 83 for a list of needed kits.

**Table 3.1 Multicoupler Kits**

Combine	AGCO Kit Number
Challenger®	71530662
Gleaner® R/S Series	71414706
Massey Ferguson®	71411594

**⚠ DANGER**

To prevent injury or death from the unexpected start-up of the machine, always stop the engine and remove the key from the ignition before leaving the operator's seat for any reason.

**⚠ DANGER**

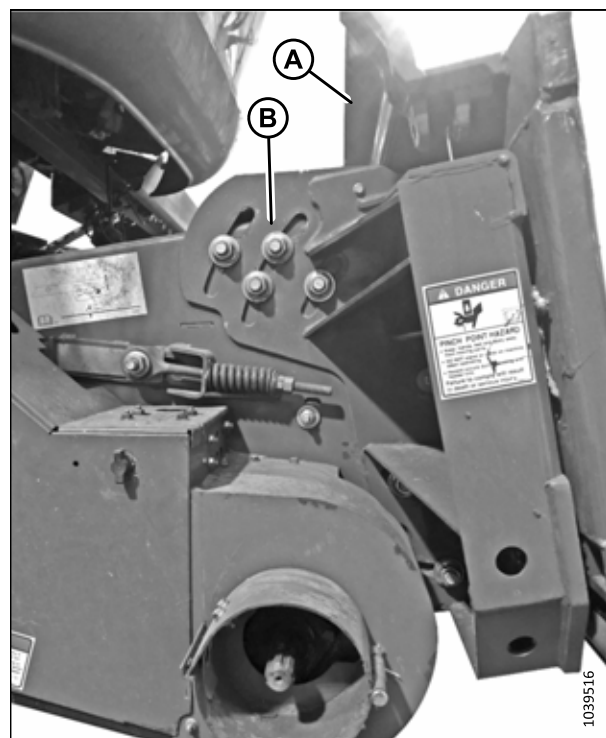
Ensure that all bystanders have cleared the area.

**IMPORTANT:**

If the combine is **NOT** equipped with a rock trap, feeder house faceplate (A) **MUST** be in mid-position (B). For instructions on adjusting the faceplate, refer to the combine operator's manual.

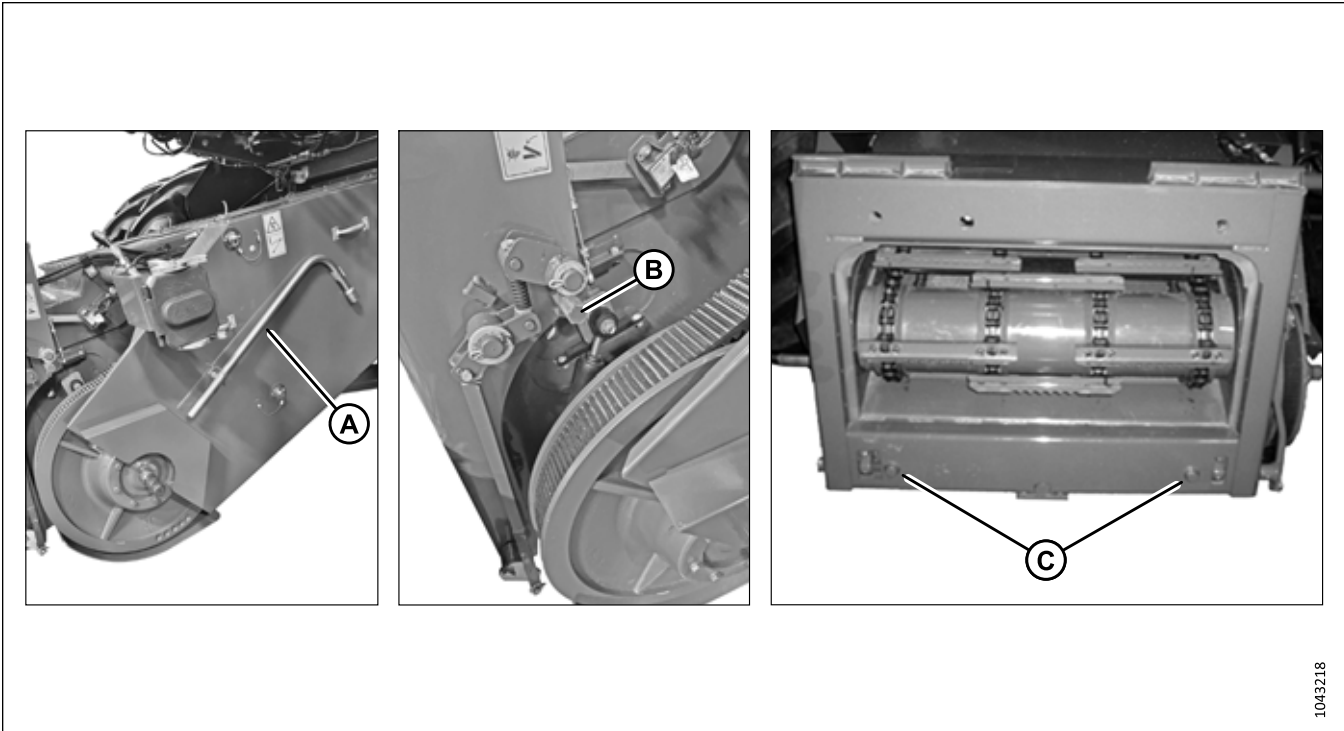
**NOTE:**

A rock trap prevents rocks or debris from entering the combine, and is located on the front of the combine and behind the feeder house.



**Figure 3.85: Faceplate Tilted to Mid-Position on Unspecified Combine**

## OPERATION



**Figure 3.86: Feeder House**

1. Shut down the engine, and remove the key from the ignition.
2. Retrieve feeder house tool (A) and install it onto latch bolt (B). Retract feeder house pins (C) by operating the latch.

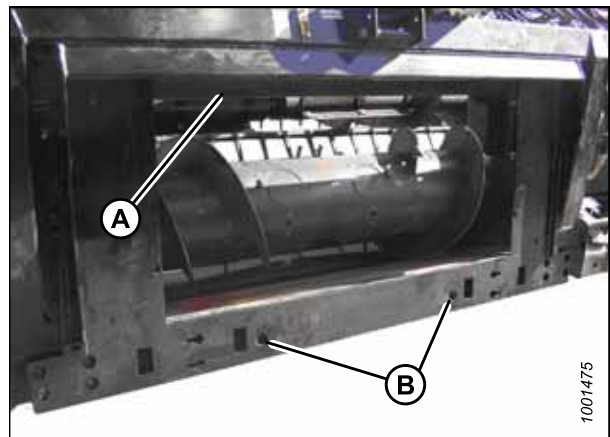
**NOTE:**

The combine feeder house may not be exactly as shown. If the latch mechanism is different than what is described in this procedure, refer to the combine operator's manual for instructions.

3. Slowly approach the header until the feeder house is directly under float module top cross member (A).

**NOTE:**

Ensure that alignment pins (C) (refer to Figure 3.86, page 84) on the feeder house align with holes (B) in the float module frame.



**Figure 3.87: Float Module**



## OPERATION

4. Raise the feeder house slightly to lift the header, ensuring feeder house saddle (A) is properly engaged in the float module frame.
5. Shut down the engine, and remove the key from the ignition.

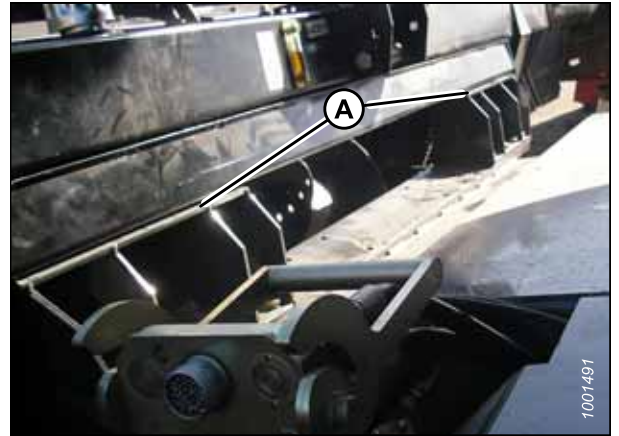


Figure 3.88: Feeder House and Float Module

6. Use latch mechanism (B) to engage pins (A) with the float module.

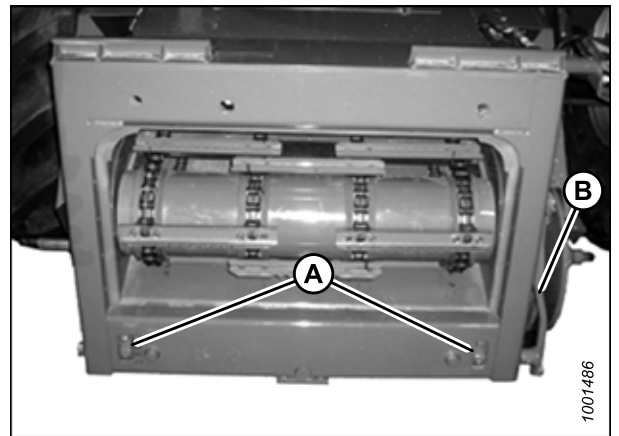
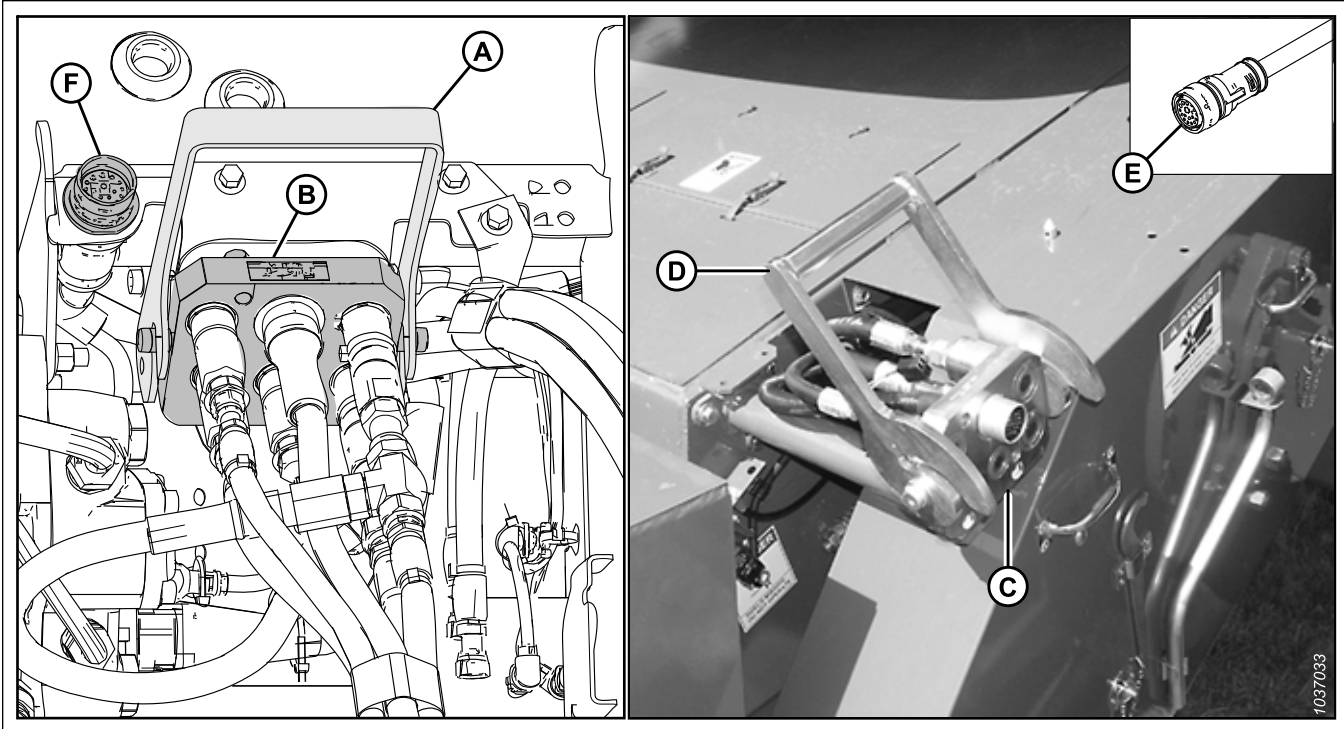
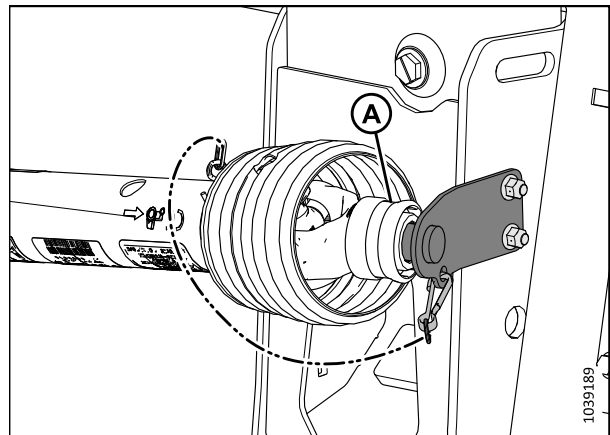


Figure 3.89: AGCO Group Feeder House



**Figure 3.90: Hydraulics and Electrical Multicoupler**

7. Raise handle (A) to release multicoupler (B) from the float module.
8. Raise handle (D) on the combine to the fully open position. Clean the mating surfaces of multicoupler (B) and receptacle (C).
9. Install multicoupler (B) into combine receptacle (C). Pull handle (D) to engage the multicoupler into the receptacle.
10. Retrieve cab control kit connector C81A (E) from the storage location on the combine and connect it to connector C81B (F) on the float module. Turn the collar on the connector to lock it.
11. Pull driveline collar (A) back to release the driveline from the support bracket. Remove the driveline from the support bracket.



**Figure 3.91: Driveline in Storage Position**

## OPERATION

12. Pull back collar (A) on the end of the driveline, and push the driveline onto combine output shaft (B) until the collar is locked.

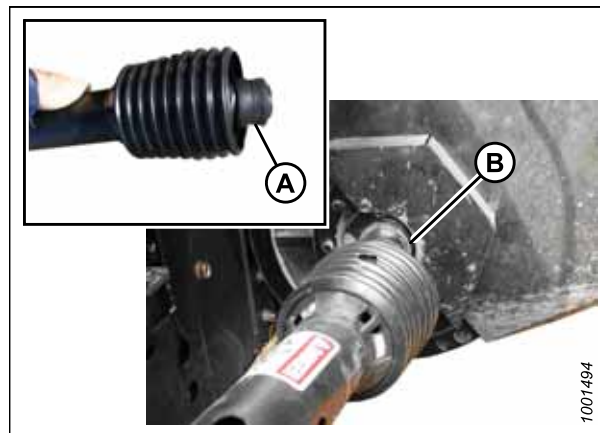


Figure 3.92: Driveline

13. Proceed as follows:

- If the header is going to be used in the field now, disengage the float locks by pulling each float lock handle (A) away from the float module and into unlocked position (B).
- If the header is **NOT** going to be used in the field now, engage the float locks by pushing each float lock handle (A) toward the float module and into locked position (C).

### NOTE:

The illustration shows the float lock handle on the right side of the header. The float lock handle on the left side of the header is the opposite.

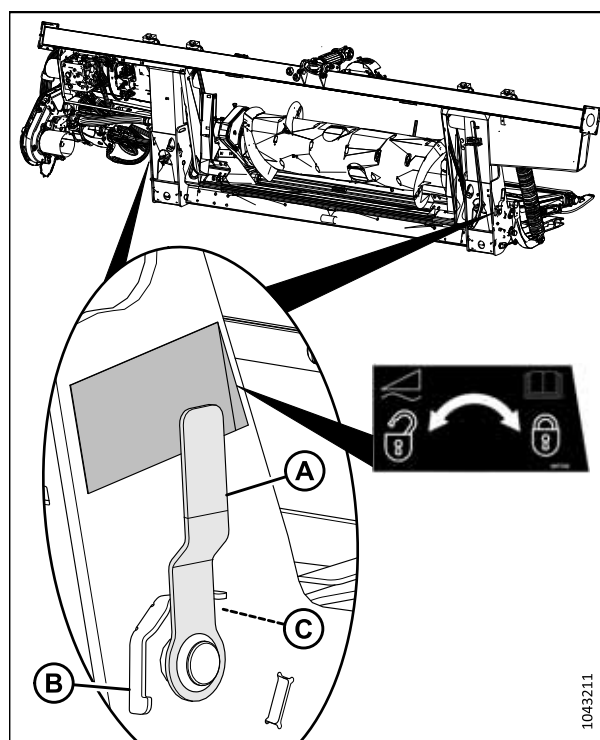


Figure 3.93: Float Lock Handle

### *Detaching Header from a Challenger®, Gleaner®, or Massey Ferguson® Combine*

Follow these instructions to remove the hydraulic and electrical connectors and detach the header from the combine.

### **DANGER**

To prevent bodily injury or death from the unexpected start-up or fall of a raised machine, always stop the engine, remove the key, and engage the safety props before going under the header for any reason.

### **DANGER**

Ensure that all bystanders have cleared the area.

## OPERATION

1. Choose a level area and position the header slightly above the ground.
2. Shut down the engine, and remove the key from the ignition.

### IMPORTANT:

If transport wheels are installed, set the wheels to the storage or uppermost working position. If the wheels are not in position, the header may tilt forward and make reattachment difficult. For instructions, refer to *Adjusting EasyMove™ Transport Wheels, page 191*.

### IMPORTANT:

If stabilizer wheels are installed, set the wheels to the storage or uppermost working position. If the wheels are not in position, the header may tilt forward and make reattachment difficult. For instructions, refer to *Adjusting Stabilizer Wheels, page 190*.

3. Engage the float locks by pulling each float lock handle (A) away from the float module and setting it in locked position (B).

### NOTE:

The illustration shows the float lock handle on the right side of the header. The float lock hand on the left side of the header is the opposite.

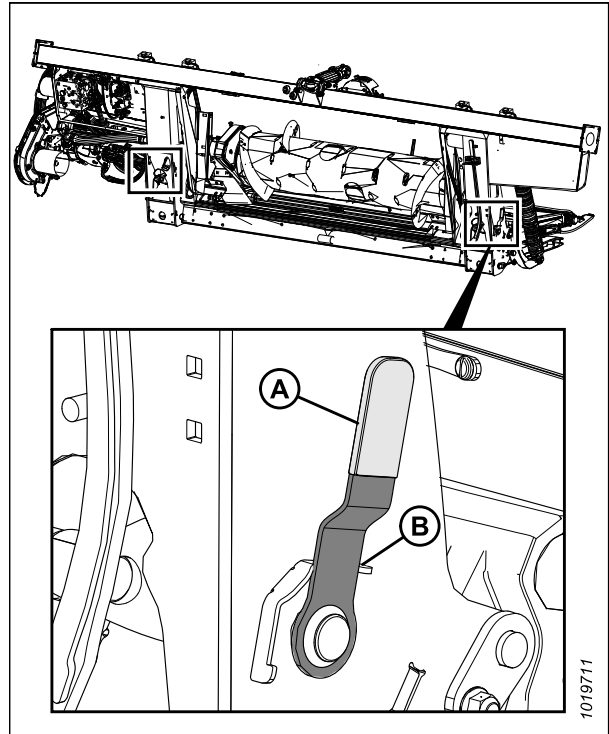


Figure 3.94: Float Lock Handle – Right Shown in Detail, Left Opposite

4. Disconnect driveline (A) from combine output shaft (B).

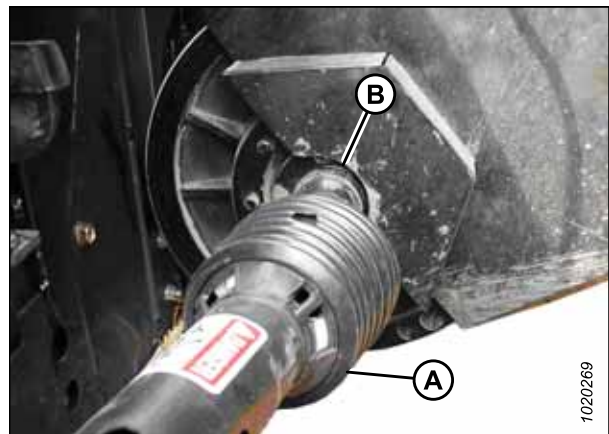


Figure 3.95: Driveline

## OPERATION

5. Store driveline on driveline support bracket (B) by pulling back collar (A) on the driveline and fitting it over the support bracket body and releasing the collar so it locks into place.

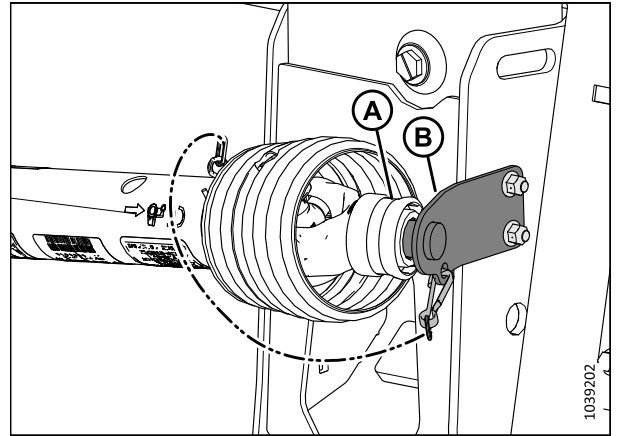
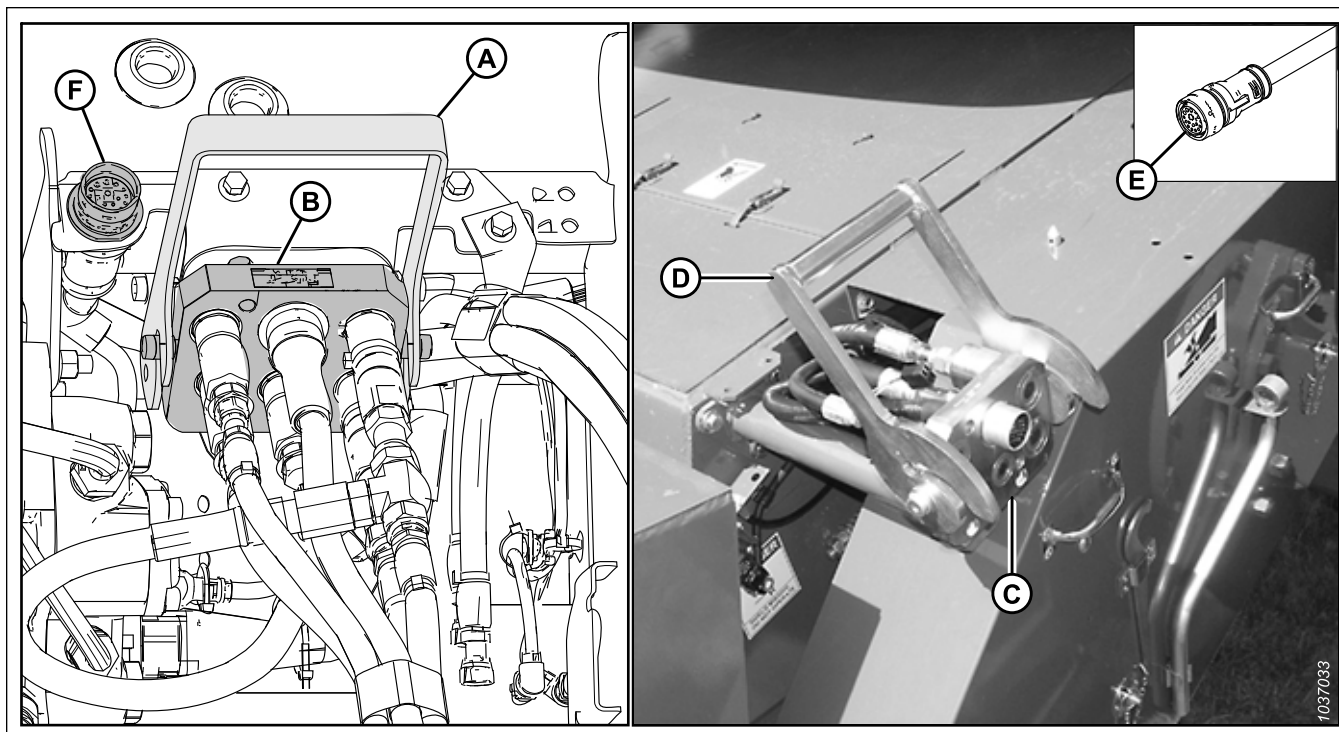


Figure 3.96: Storing the Driveline

## OPERATION



**Figure 3.97: Hydraulics and Electrical Multicoupler**

6. Turn collar to release cab kit control connector from receptacle C81B (F), and return connector (E) to a storage location on the combine.
7. Raise handle (D) to the fully open position to release the multicoupler from receptacle (C) on the combine.
8. Raise handle (A) on the float module, and place multicoupler (B) on the float module receptacle.
9. Lower handle (A) to lock multicoupler (B).



## OPERATION

10. Use lock handle (B) to retract lugs (A) at the base of the feeder house.

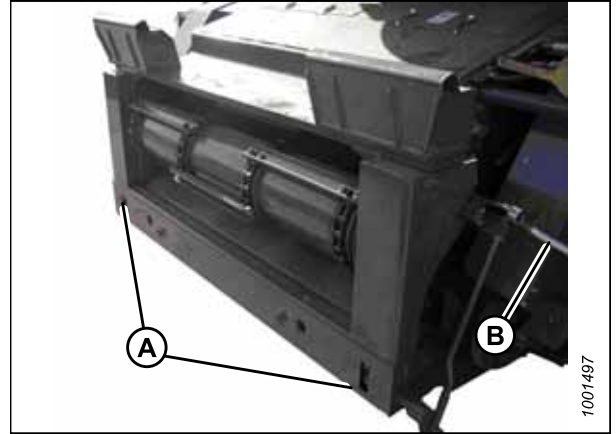


Figure 3.98: Challenger® and Massey Ferguson®

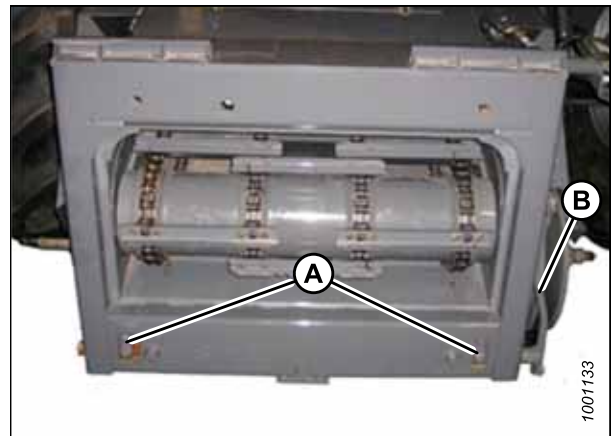


Figure 3.99: Gleaner® R and S Series

11. Lower the feeder house until saddle (A) disengages and clears float module support (B).
12. Back the combine away slowly from the float module.

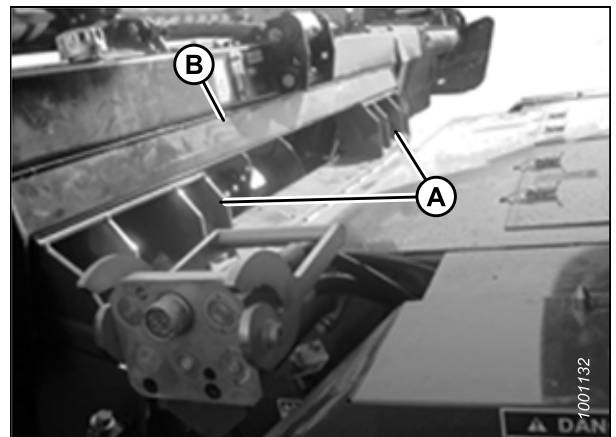


Figure 3.100: Float Module on Combine

### 3.6.3 CLAAS Combines

To attach the header to or detach it from a CLAAS combine, follow the relevant procedure in this section.

The FD2 Series FlexDraper® Header is compatible with CLAAS/CAT Lexion 500 series, CLAAS Lexion 600, 700, 6000, 7000, and 8000 series, and CLAAS Trion 600 and 700 series combines.

## OPERATION

### Attaching Header to CLAAS Combine

The header will need to be physically connected to the combine's feeder house, and the electrical and hydraulic connections completed.

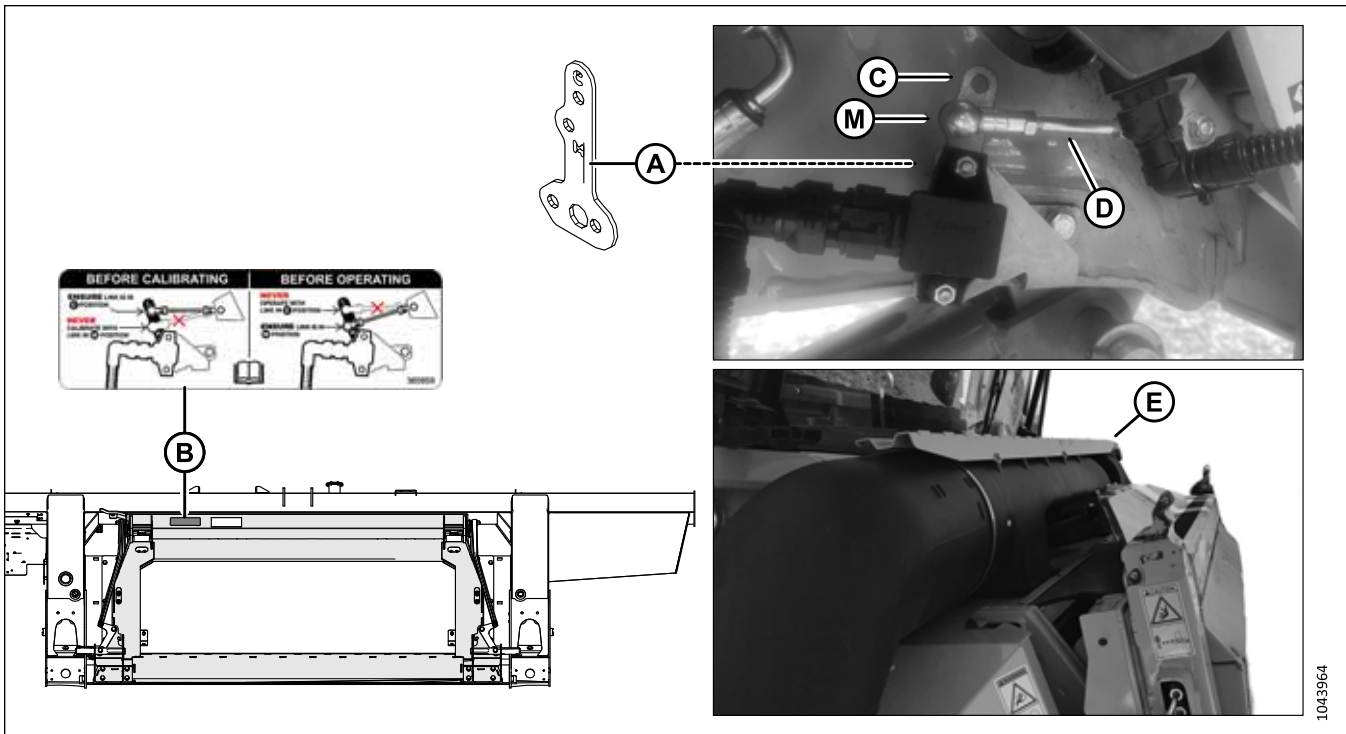


Figure 3.101: Limiter Link, Decal, and Feeder House

#### IMPORTANT:

Before a CLAAS Lexion 6000/7000/8000 series, or CLAAS Trion 600/700 series combine is attached to the header for the first time, fore/aft tilt sensor limiter link (A) (MD #357776) must be installed on the combine's feeder house, and a feeder house fore/aft tilt calibration must be performed. When properly configured, the limiter link prevents interference between the float module and the feeder house dust blower shroud (E).

- The initial installation of the limiter link, and the initial feeder house fore/aft tilt calibration, is done by a Dealer.
- Sensor linkage (D) must be installed in limiter link hole "C" (C), and the header must be detached from the combine, before performing a feeder house fore/aft tilt calibration. Hole "C" is only used for feeder house fore/aft tilt calibrations.
- Sensor linkage (D) must be installed in limiter link hole "M" (M) as shown before attaching the header to the combine. Hole "M" is used for operating the header, or performing any calibration that is **NOT** a feeder house fore-aft tilt calibration. Examples of calibrations that use hole "M" include auto header height control (AHC), reel height, and reel fore-aft calibrations.
- Decal (B) (MD #360859) is installed on the float module transition frame to remind the Operator when the sensor linkage must be installed in hole "C" or hole "M".
- For limiter link installation and feeder house fore/aft tilt calibration instructions, refer to [Installing Limiter Link and Performing a Fore/Aft Tilt Calibration – CLAAS Lexion 6000, 7000 and 8000 Series, and CLAAS Trion 600 and 700 Series Combines, page 97](#).



## OPERATION

### IMPORTANT:

If the combine is **NOT** equipped with a rock trap, feeder house faceplate (A) **MUST** be in mid-position (B). For instructions on adjusting the faceplate, refer to the combine operator's manual.

### NOTE:

A rock trap prevents rocks or debris from entering the combine, and is located on the front of the combine and behind the feeder house.

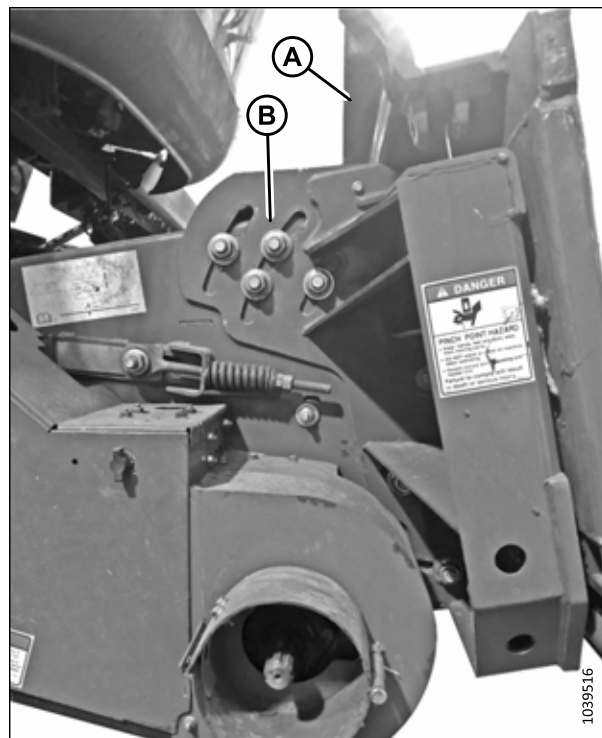


Figure 3.102: Faceplate Tilted to Mid-Position on Unspecified Combine

### DANGER

To prevent injury or death from the unexpected start-up of the machine, always stop the engine and remove the key from the ignition before leaving the operator's seat for any reason.

### DANGER

Ensure that all bystanders have cleared the area.

1. Shut down the engine, and remove the key from the ignition.
2. Move handle (A) on the float module to the raised position. Ensure that pins (B) at the bottom corners of the float module are retracted.

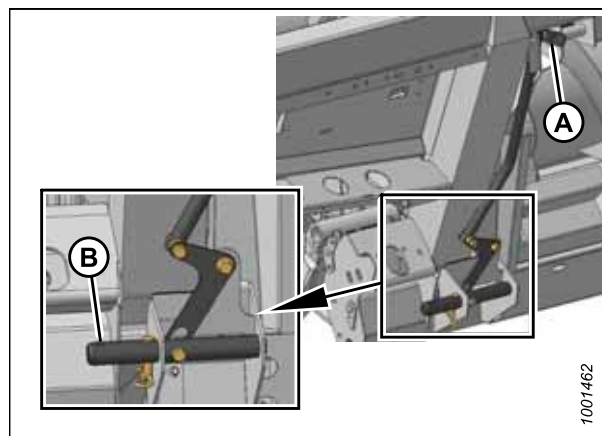


Figure 3.103: Pins Retracted

## OPERATION

3. Slowly drive the combine up to the header until feeder house saddle (A) is directly under float module top cross member (B).
4. Raise the feeder house slightly to lift the header. Ensure that the feeder saddle is fully engaged with the float module's frame.
5. Shut down the engine, and remove the key from the ignition.

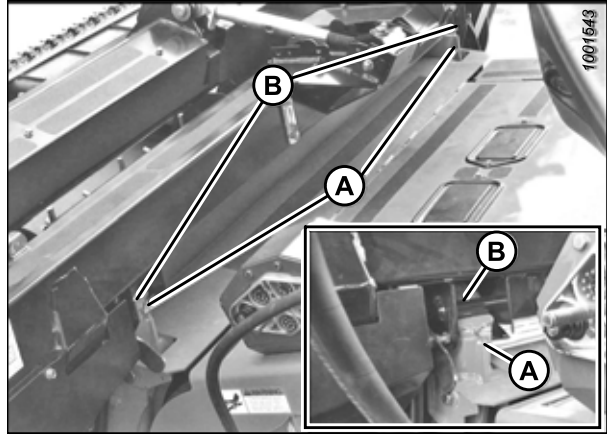


Figure 3.104: Header on Combine

6. Remove locking pin (B) from float module pin (A).

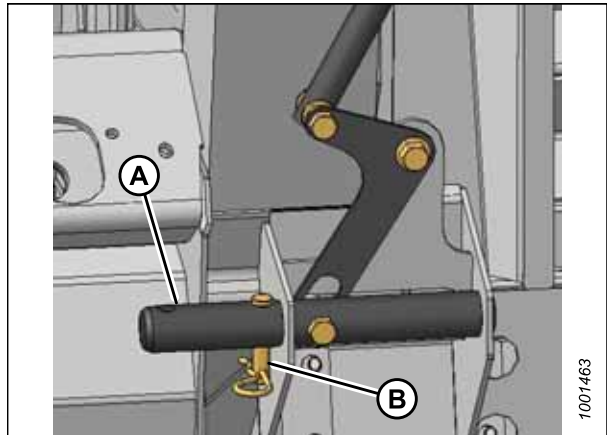


Figure 3.105: Locking Pins

7. Lower handle (A) to engage float module pins (B) into the feeder house. Reinsert locking pin (C) as shown. Secure the locking pin with the hairpin.

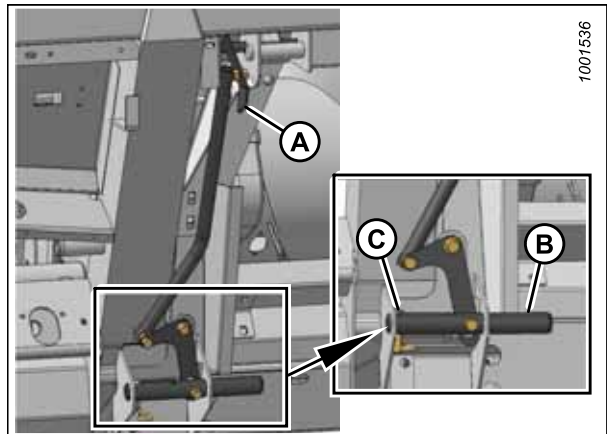


Figure 3.106: Engaging Pins

## OPERATION

8. Remove float module receptacle cover (A). Clean the receptacle.

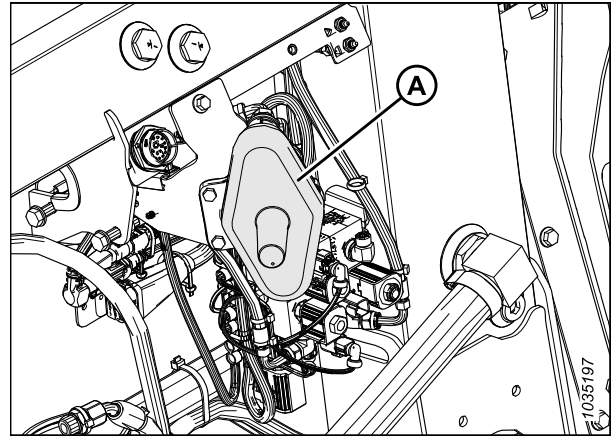


Figure 3.107: Receptacle Cover

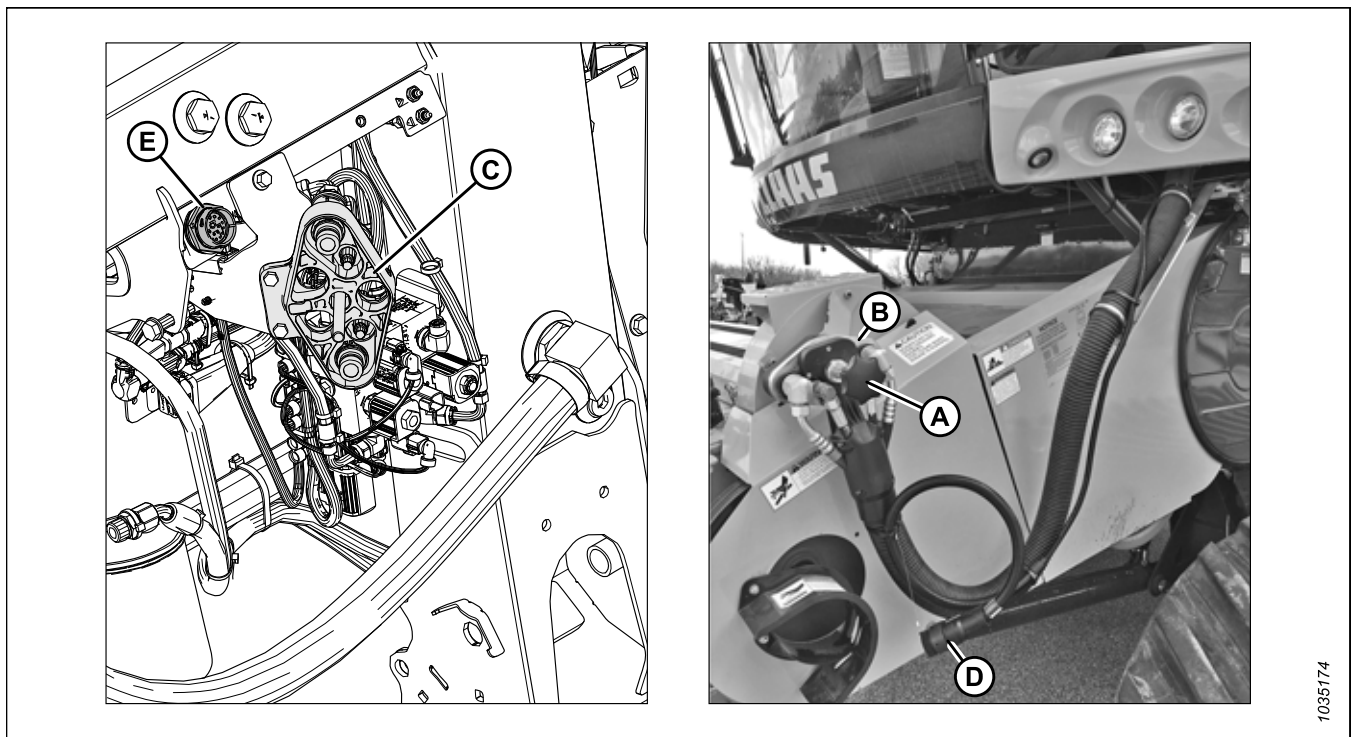


Figure 3.108: Multicoupler and Electrical Connections

9. Unscrew knob (A) on combine coupler (B) to release the coupler from the receptacle.
10. Clean coupler (B) and the receptacle.
11. Install combine coupler (B) onto float module receptacle (C). Secure the coupler by turning knob (A).
12. **If MacDon in-cab controls are installed:** Remove cab control kit connector C81A (D) from the storage location on the combine and connect it to C81B (E) on the float module. Turn the collar on the connector to lock it in place.

## OPERATION

13. Place float module receptacle cover (A) onto the combine receptacle as shown in Figure 3.109, page 96.

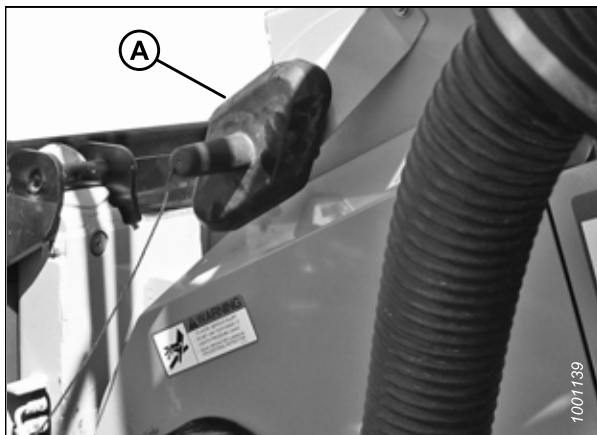


Figure 3.109: Receptacle Cover

14. Pull driveline collar (A) back to release the driveline from the support bracket (B). Remove the driveline from the support bracket.

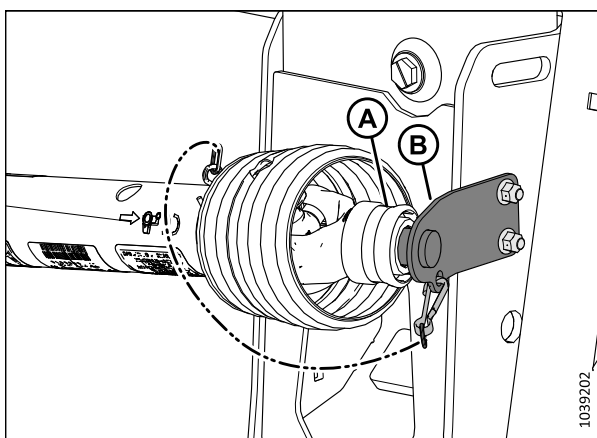


Figure 3.110: Driveline in Storage Position

15. Attach driveline (A) to the combine output shaft.

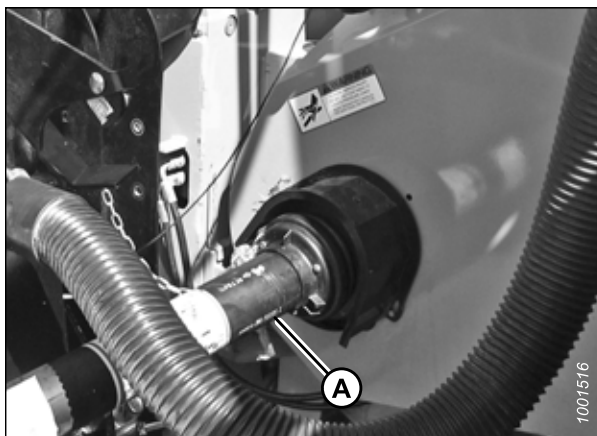


Figure 3.111: Driveline and Output Shaft

## OPERATION

16. Proceed as follows:

- If the header is going to be used in the field now, disengage the float locks by pulling each float lock handle (A) away from the float module and into unlocked position (B).
- If the header is **NOT** going to be used in the field now, engage the float locks by pushing each float lock handle (A) toward the float module and into locked position (C).

### NOTE:

The illustration shows the float lock handle on the right side of the header. The float lock handle on the left side of the header is the opposite.

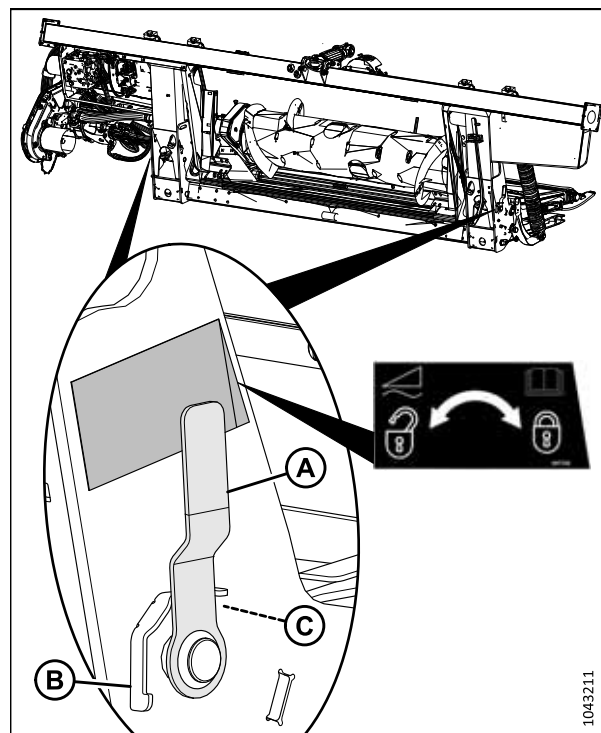


Figure 3.112: Float Lock Handle

### Installing Limiter Link and Performing a Fore/Aft Tilt Calibration – CLAAS Lexion 6000, 7000 and 8000 Series, and CLAAS Trion 600 and 700 Series Combines

To prevent interference between the float module and the feeder house dust blower shroud, a limiter link must be installed, calibrated, and configured on CLAAS Lexion 6000, 7000 and 8000 series, and CLAAS Trion 600 and 700 series combines before the combine is attached to the header for the first time.

### DANGER

To prevent injury or death from the unexpected start-up or fall of a raised machine, always shut off the engine and remove the key from the ignition before leaving the operator's seat or making adjustments to the machine. If the feeder house is fully raised, always engage the safety props.

### DANGER

Ensure that all bystanders have cleared the area.

### IMPORTANT:

To prevent damage caused by interference between the header and feeder house dust blower shroud, make sure the combine is detached from the header before raising the feeder house or performing fore/aft tilt calibration.

1. Park the combine on a level surface.
2. Lower or raise the feeder house fully.

## OPERATION

3. In CEBIS, navigate to HEADER (A), SETTINGS (B), HEADER PITCH (C). Adjust the faceplate pitch to 0.
4. Shut down the engine, and remove the key from the ignition.
5. If the feeder house is raised, engage the header safety props. For instructions, refer to the combine operator's manual.

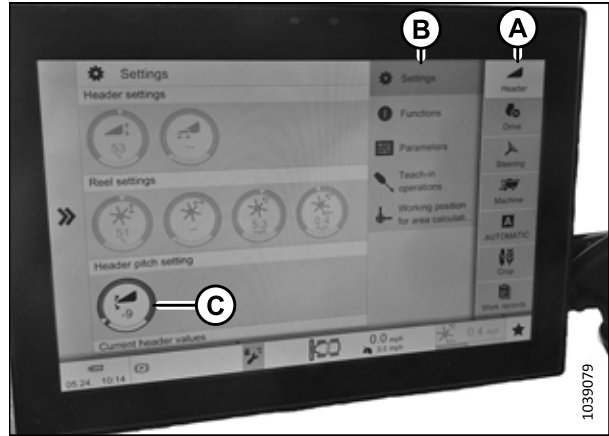


Figure 3.113: CEBIS Settings

6. Proceed as follows:
  - If installing limiter link (A) onto the feeder house, proceed to the next step.
  - If limiter link (A) is already installed on the feeder house, proceed to Step [14, page 99](#) for calibration instructions.

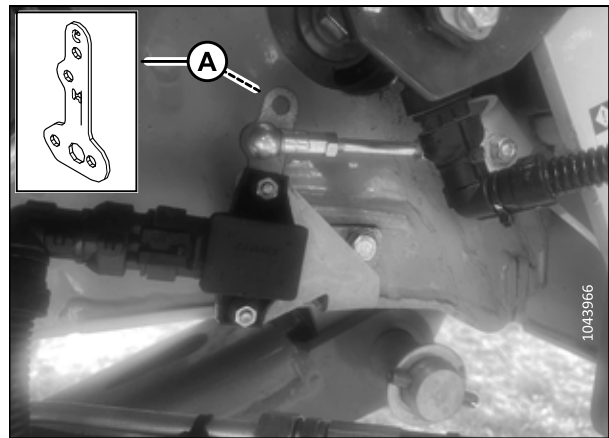


Figure 3.114: Limiter Link

7. Locate feeder house fore/aft tilt sensor (B) on the right side of the combine's feeder house, near header safety prop (A).

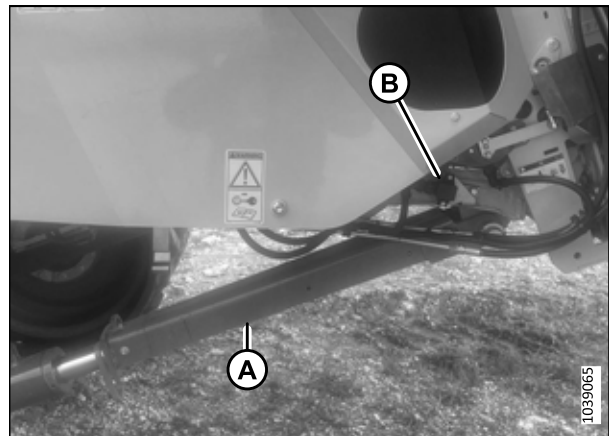


Figure 3.115: Sensor Limiter Link Location – Feeder House



## OPERATION

8. Remove the nut that secures linkage (A) to the sensor arm.
9. Remove linkage (A) from the sensor arm.

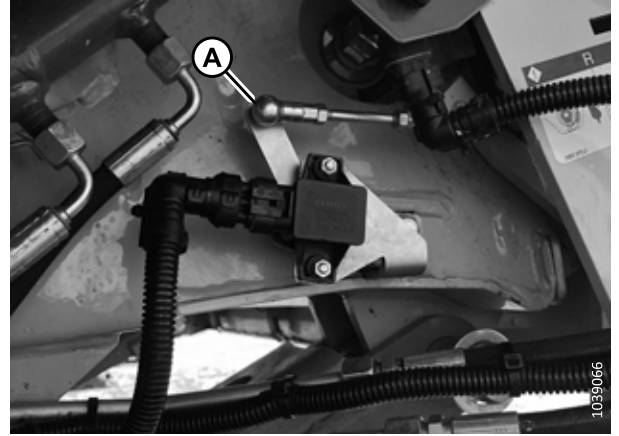


Figure 3.116: Sensor Arm Linkage

10. Remove two bolts (A) that secure sensor arm (B) to the sensor.

**NOTE:**

Do not unbolt the sensor from the combine.

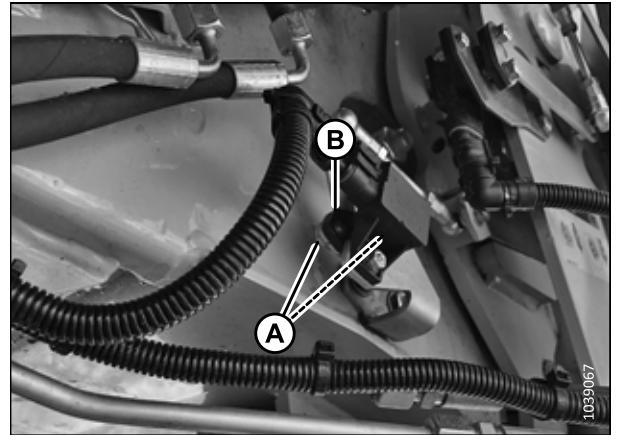


Figure 3.117: Sensor Arm

11. Install sensor arm (A) onto sensor (C). The bottom pointed end (B) of the sensor arm and the sensor pivot that the arm bolts to should both point towards the back of the combine. The extended part of the sensor arm should be pointing up.
12. Install the two bolts to secure sensor arm (A) to sensor (C).
13. Install linkage (D) into the upper hole "C" on the sensor arm.

**IMPORTANT:**

Make sure the sensor arm is installed in hole "C" before calibrating the system. Calibrating the system with the sensor arm installed in hole "M", instead of hole "C", will lead to mechanical interference once the header is connected to the combine.

14. If the header safety props are engaged, disengage them now. For instructions, refer to the combine operator's manual.
15. Start the engine.

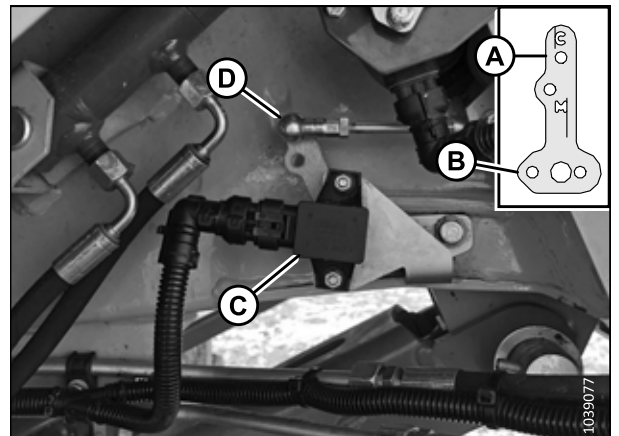


Figure 3.118: Sensor Arm Linkage

## OPERATION

### NOTE:

Step 17, [page 100](#) and Step 18, [page 100](#) describe performing a fore/aft tilt calibration.

16. In CEBIS, navigate to HEADER (A), TEACH IN OPERATIONS (B), and then HEADER PITCH (C).

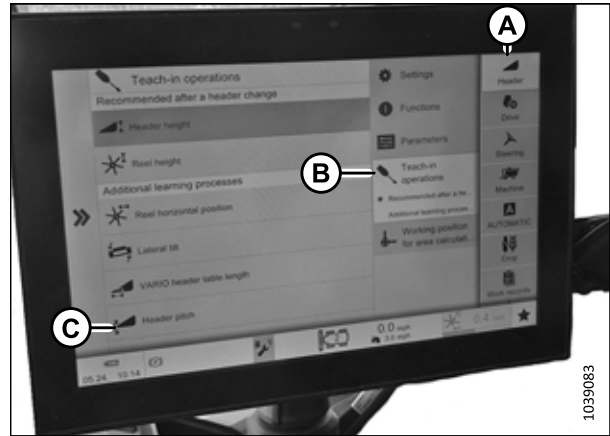


Figure 3.119: CEBIS Settings

17. Press arrow (A) to start the procedure. Follow the on-screen prompts.
18. Lower or raise the feeder house fully.
19. Shut down the engine, and remove the key from the ignition.
20. If the feeder house is raised, engage the header safety props.

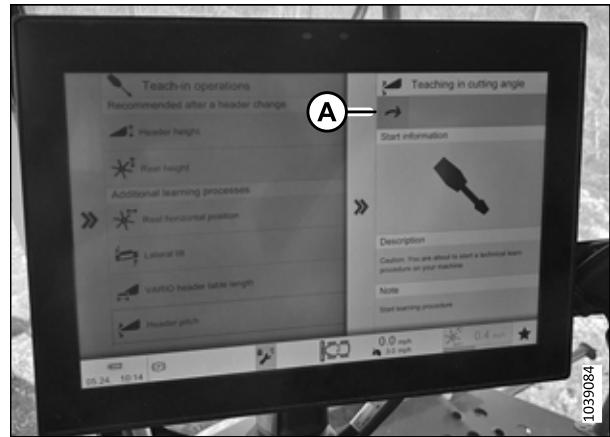


Figure 3.120: CEBIS Settings

21. Change the sensor linkage arm position from upper hole (A) labeled "C" to lower hole (B) labeled "M".
22. If the header safety props are engaged, disengage them now. For instructions, refer to the combine operator's manual.
23. Start the engine.
24. Connect the combine to the header. For instructions, refer to [Attaching Header to CLAAS Combine, page 92](#).

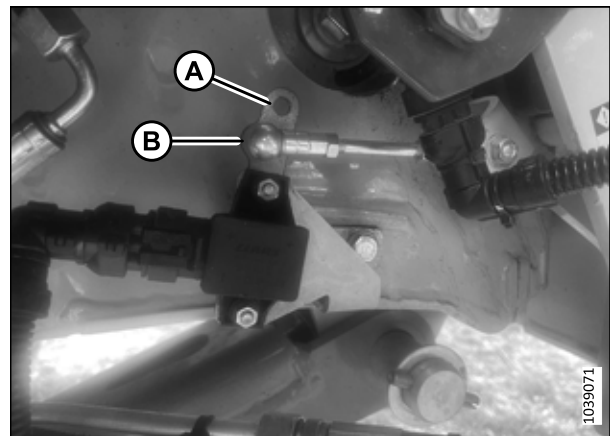


Figure 3.121: Sensor Arm Linkage



## OPERATION

25. Slowly tilt the combine faceplate back to ensure that there is **NO** interference between the header and step (A) on the combine feeder house.
26. Tilt the faceplate forward until "0" is shown on the display.



Figure 3.122: Step Contact

### *Detaching Header from CLAAS Combine*

The header will need to be physically disconnected from the combine, and the hydraulic and electrical connections will need to be removed.

#### **DANGER**

To prevent injury or death from the unexpected start-up of the machine, always stop the engine and remove the key from the ignition before leaving the operator's seat for any reason.

#### **DANGER**

Ensure that all bystanders have cleared the area.

1. Choose a level area and position the header slightly above the ground.
2. Shut down the engine, and remove the key from the ignition.

#### **IMPORTANT:**

If transport wheels are installed, set the wheels to the storage or uppermost working position. If the wheels are not in position, the header may tilt forward and make reattachment difficult. For instructions, refer to [Adjusting EasyMove™ Transport Wheels, page 191](#).

#### **IMPORTANT:**

If stabilizer wheels are installed, set the wheels to the storage or uppermost working position. If the wheels are not in position, the header may tilt forward and make reattachment difficult. For instructions, refer to [Adjusting Stabilizer Wheels, page 190](#).

## OPERATION

- Engage the float locks by pulling each float lock handle (A) away from the float module and setting it in locked position (B).

**NOTE:**

The illustration shows the float lock handle on the right side of the header. The float lock on the left side of the header is the opposite.

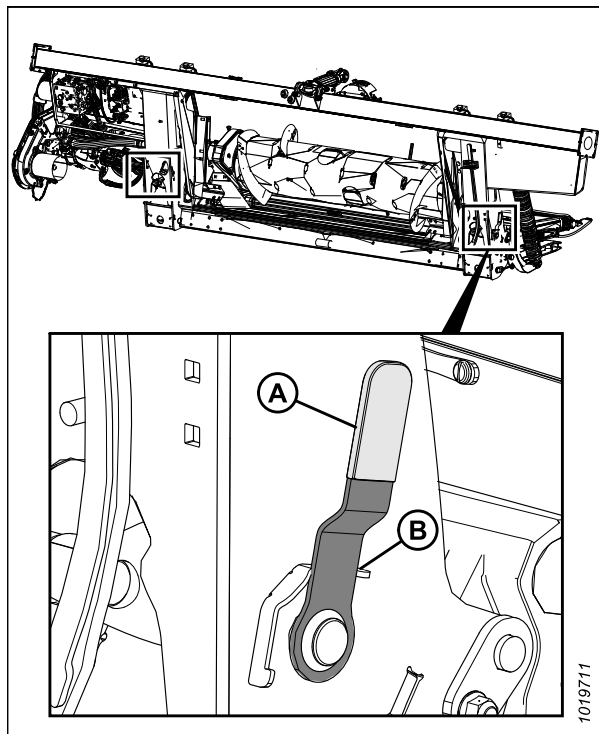


Figure 3.123: Float Lock Handle

- Disconnect driveline (A) from the combine.

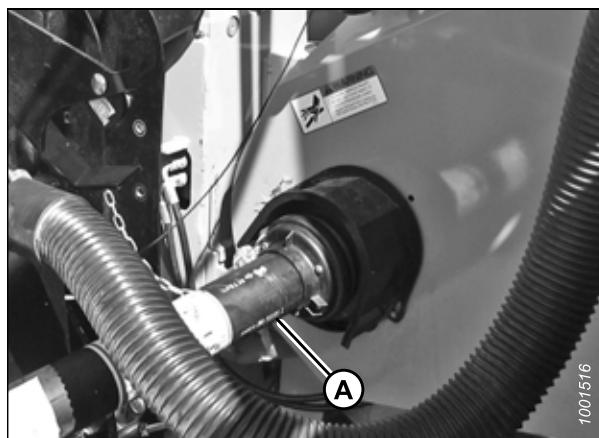


Figure 3.124: Driveline

## OPERATION

5. Store the driveline on driveline support bracket (B) by pulling back collar (A) on the driveline and fitting it onto support bracket (B). Release the collar so it locks into place on the bracket.

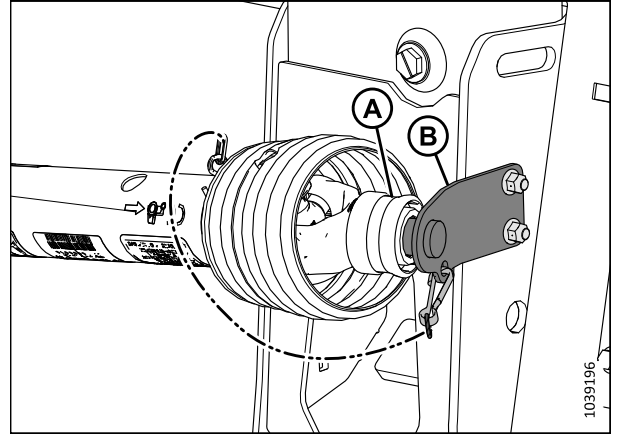


Figure 3.125: Driveline in Storage Position – Driveline B7039

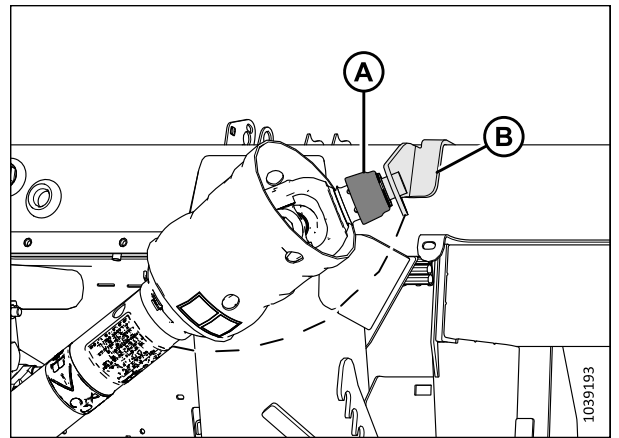


Figure 3.126: Driveline in Storage Position – Sidehill/Hillside Driveline B7182

6. Remove cover (A) from the combine receptacle.

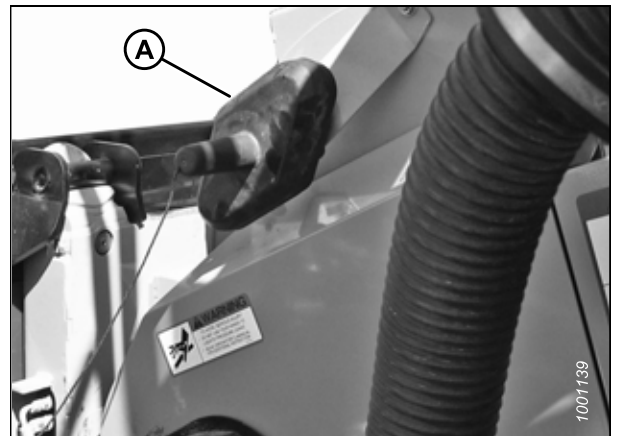


Figure 3.127: Cover

## OPERATION

7. Position coupler (A) onto the combine receptacle, and turn knob (B) to secure the coupler to the receptacle.
8. If MacDon in-cab controls are installed, disconnect cab control connector C81A from receptacle C81B and secure the connector to its storage location on the combine.

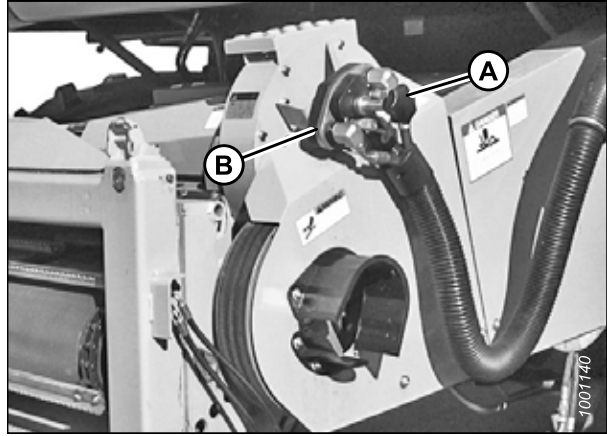


Figure 3.128: Combine Coupler

9. Place cover (A) on the float module receptacle.

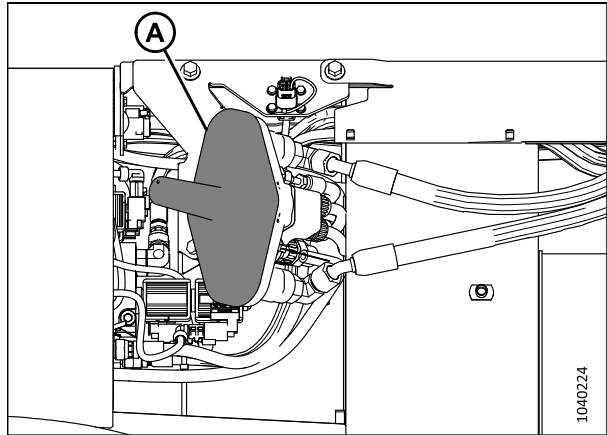


Figure 3.129: Float Module

10. Remove locking pin (A) from float module pin (B).
11. Raise handle (C) to disengage float module pins (B) from the feeder house.
12. Replace locking pin (A) in the float module pin, and secure it with the hairpin.

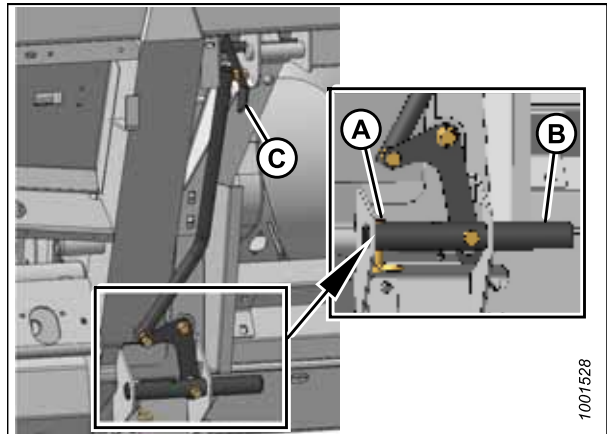


Figure 3.130: Feeder House Locks

## OPERATION

13. Lower the feeder house until feeder house posts (A) disengage float module (B).
14. Slowly back the combine away from the float module.

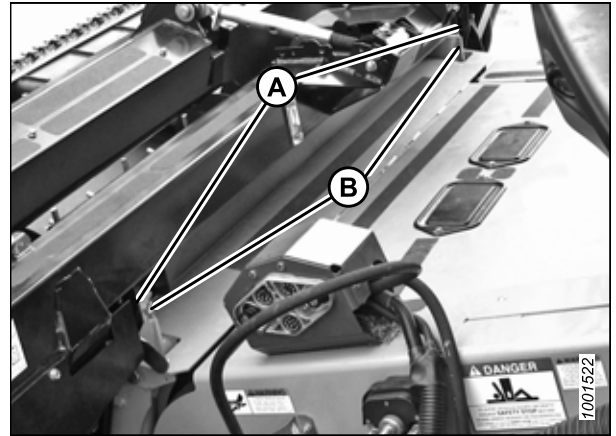


Figure 3.131: Header on Combine

### 3.6.4 IDEAL™ Series Combines

To attach the header to or detach it from an IDEAL™ combine, follow the relevant procedure in this section.

#### *Attaching Header to IDEAL™ Series Combine*

The header will need to be physically connected to the combine's feeder house, and the electrical and hydraulic connections completed.

#### **DANGER**

To prevent injury or death from the unexpected start-up of the machine, always stop the engine and remove the key from the ignition before leaving the operator's seat for any reason.

#### **DANGER**

Ensure that all bystanders have cleared the area.

## OPERATION

### IMPORTANT:

If the combine is **NOT** equipped with a rock trap, feeder house faceplate (A) **MUST** be in mid-position (B). For instructions on adjusting the faceplate, refer to the combine operator's manual.

### NOTE:

A rock trap prevents rocks or debris from entering the combine, and is located on the front of the combine and behind the feeder house.

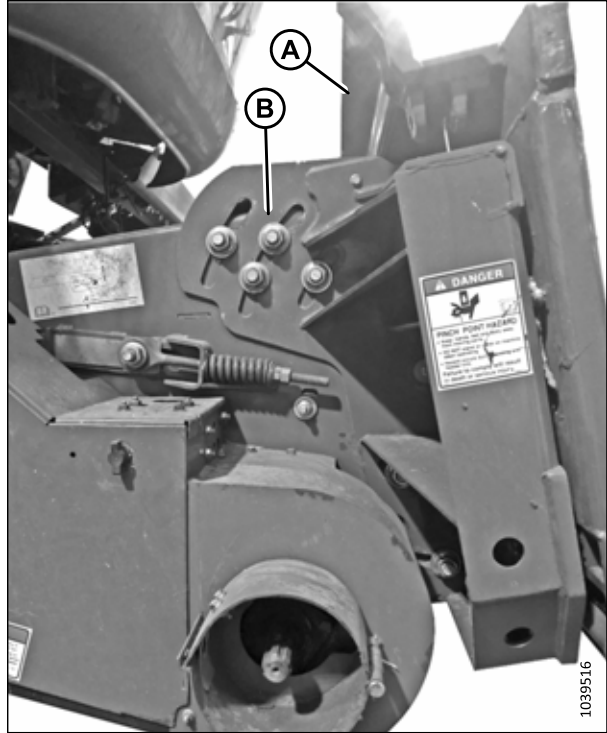


Figure 3.132: Faceplate Tilted to Mid-Position on Unspecified Combine

1. Shut down the engine, and remove the key from the ignition.
2. Pull lever (A) up to retract pins (B) at the bottom left and right sides of the feeder house.

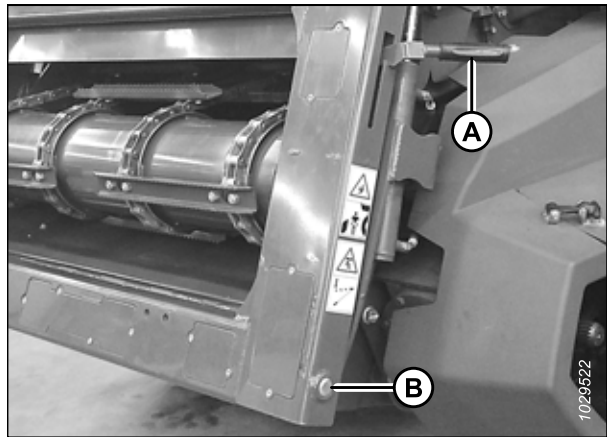
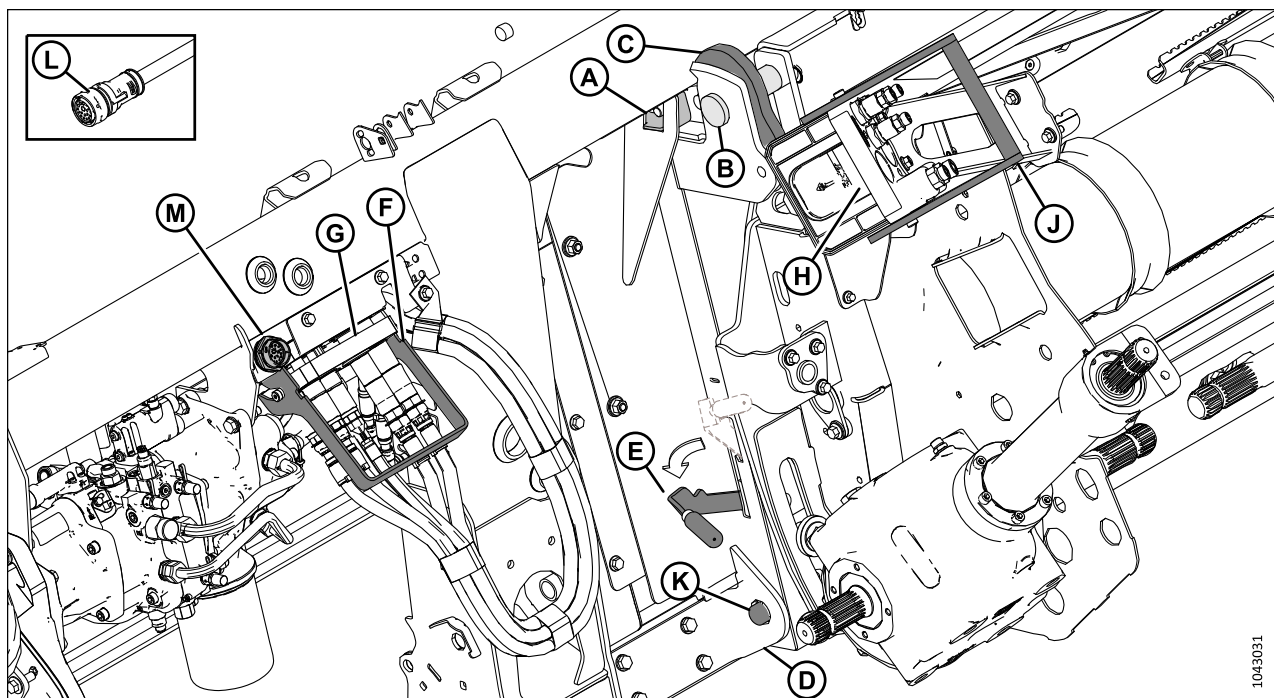


Figure 3.133: Feeder House



**Figure 3.134: Float Module with Integrated Hydraulic System (IHS)**

3. Drive the combine slowly up to the header until the feeder house is directly under top beam (A), and pins (B) are under hooks (C) on the transition frame.
4. Raise the feeder house until transition frame top beam (A) is fully resting on the feeder house. Raise the header slightly off the ground.

**IMPORTANT:**

The full weight of the header must be on the feeder house, **NOT** on pins (B).

5. Position the bottom of the feeder house so that locking pins (K) align with the holes in mount (D).
6. Shut down the engine, and remove the key from the ignition.
7. Push lever (E) down to extend locking pins (K) into mount (D).
8. Lower handle (F) to release multicoupler (G) from the header.
9. Open the cover on combine receptacle (H).
10. Push handle (J) to the fully open position.
11. Clean the mating surfaces of the coupler and receptacle.
12. Position coupler (G) onto combine receptacle (H), and pull handle (J) to fully insert the multicoupler into the receptacle.
13. Remove cab control kit connector C81A (L) from the storage location on the combine and connect it to C81B (M) on the float module. Turn the collar on the connector to lock it in place.



## OPERATION

14. Pull driveline collar (A) back to release the driveline from the support bracket. Remove the driveline from the support bracket.

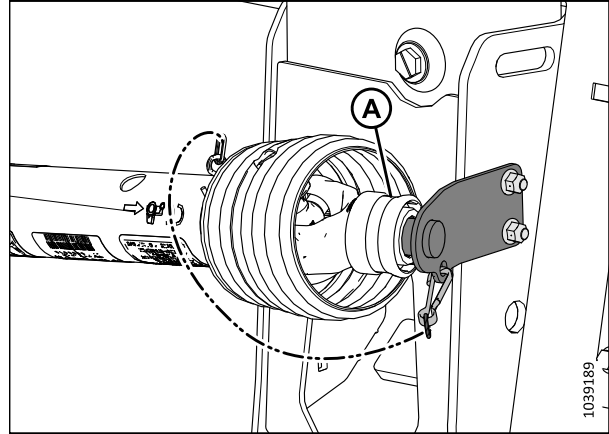


Figure 3.135: Driveline in Storage Position

15. Pull back collar (A) on the end of driveline and push it onto combine output shaft (B) until the collar locks.

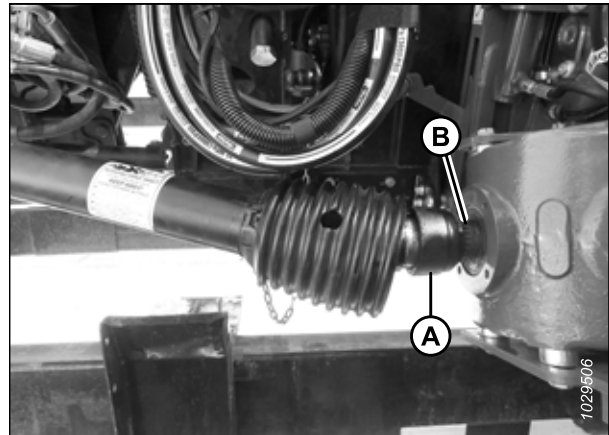


Figure 3.136: Connecting Driveline to Combine



## OPERATION

16. Proceed as follows:

- If the header is going to be used in the field now, disengage the float locks by pulling each float lock handle (A) away from the float module and into unlocked position (B).
- If the header is **NOT** going to be used in the field now, engage the float locks by pushing each float lock handle (A) toward the float module and into locked position (C).

### NOTE:

The illustration shows the float lock handle on the right side of the header. The float lock handle on the left side of the header is the opposite.

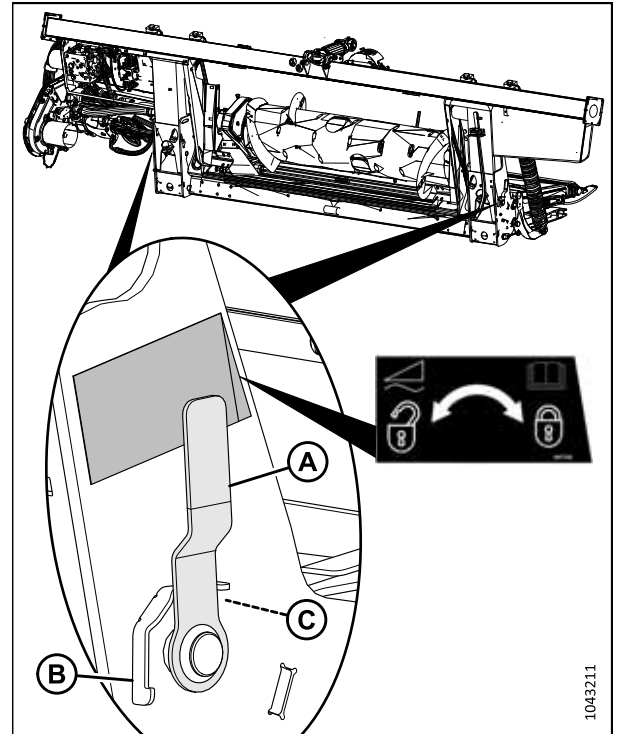


Figure 3.137: Float Lock Handle

### *Detaching Header from IDEAL™ Series Combine*

The header will need to be physically disconnected from the combine, and the hydraulic and electrical connections removed.

### **DANGER**

To prevent bodily injury or death from the unexpected startup of the machine, always stop the engine and remove the key from the ignition before leaving the operator's seat.

### **DANGER**

Ensure that all bystanders have cleared the area.

1. Park the combine on a level surface.
2. Lower the header fully.
3. Shut down the engine, and remove the key from the ignition.

## OPERATION

4. Push combine receptacle handle (B) to the fully-open position to release multicoupler (A).
5. If MacDon in-cab controls are installed, disconnect cab control connector C81A from receptacle C81B and secure the connector to its storage location on the combine.

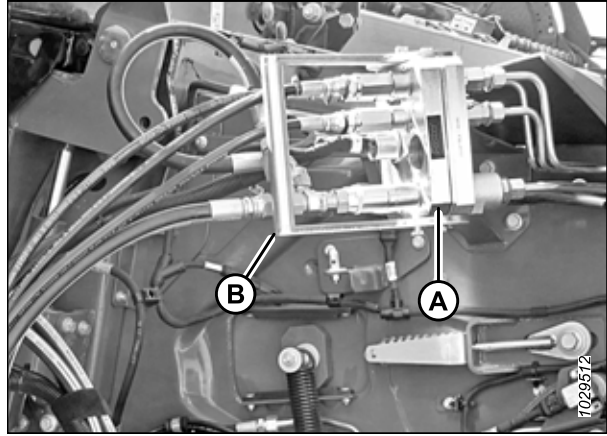


Figure 3.138: Combine Receptacle

6. Position multicoupler (B) onto the header receptacle, and move handle (A) to a vertical position to lock the multicoupler.

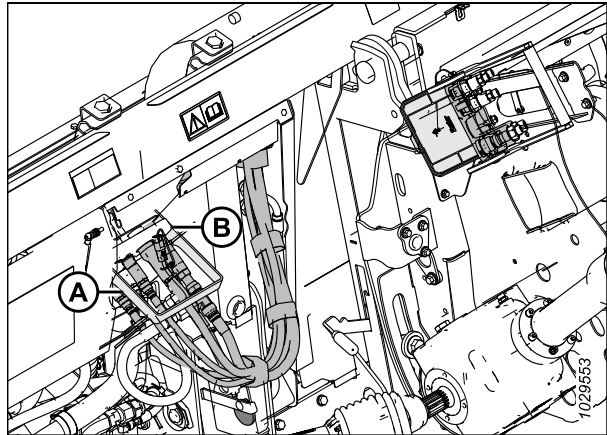


Figure 3.139: Locking Multicoupler

7. Pull back driveline collar (A) and remove the driveline from combine output shaft (B).

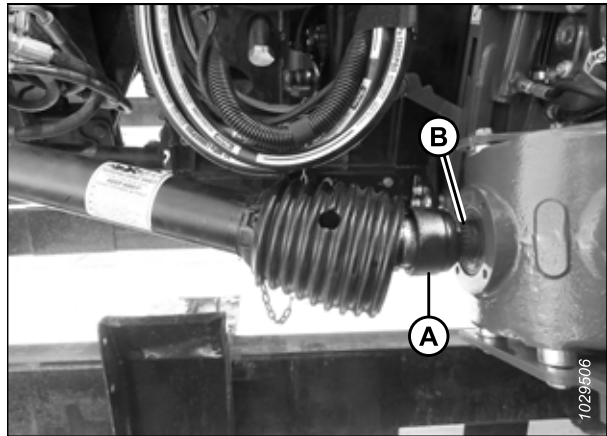


Figure 3.140: Detaching Driveline

## OPERATION

8. Store the driveline on driveline support bracket (B) by pulling back collar (A) on the driveline and fitting it onto support bracket (B). Release the collar so it locks into place on the bracket.

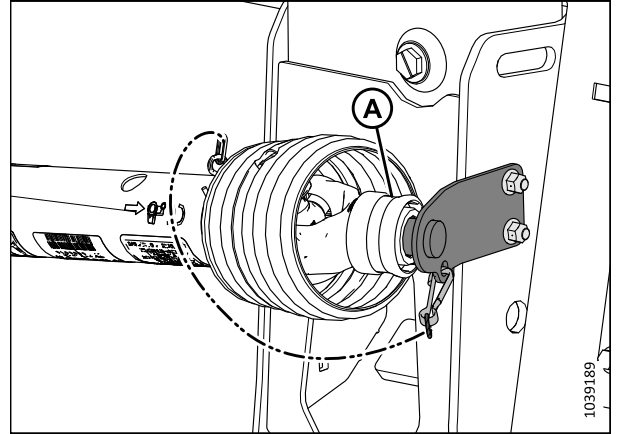


Figure 3.141: Driveline in Storage Position

9. Pull lever (A) up to retract pins (B) at the base of the feeder house.

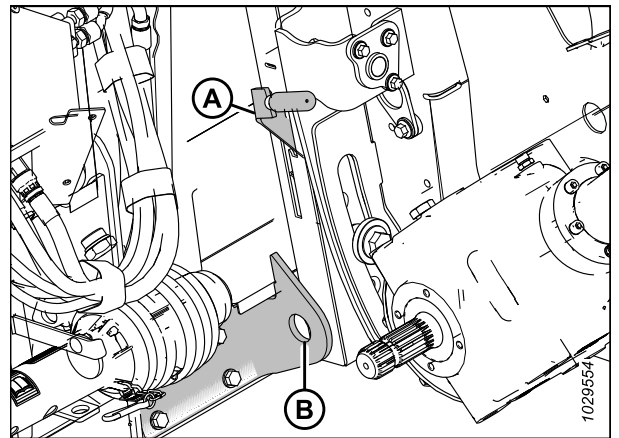


Figure 3.142: Feeder House Locking Pins

10. Start the engine.
11. Lower the header to the ground until feeder house pins (A) are clear of hooks (B).
12. Slowly back the combine away from the header.

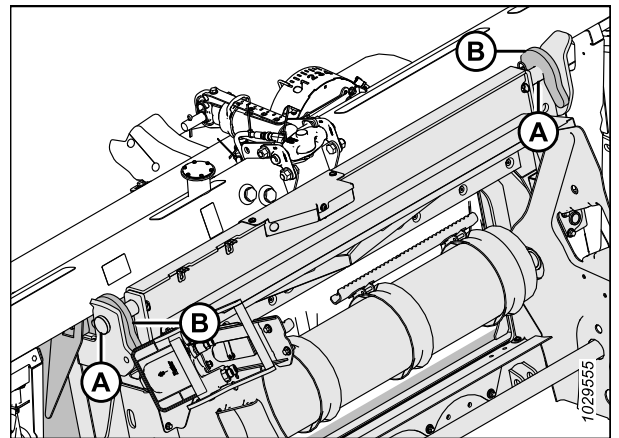


Figure 3.143: Lowering Feeder House

### 3.6.5 John Deere Combines

To attach the header to or detach it from a John Deere combine, follow the relevant procedure in this section.

The FD2 Series FlexDraper® Header is compatible with John Deere 60, 70, S, T, and X9 Series combines.

## OPERATION

### *Attaching Header to John Deere Combine*

The header will need to be physically connected to the combine's feeder house, and the electrical and hydraulic connections completed.

#### **DANGER**

To prevent injury or death from the unexpected start-up of the machine, always stop the engine and remove the key from the ignition before leaving the operator's seat for any reason.

#### **DANGER**

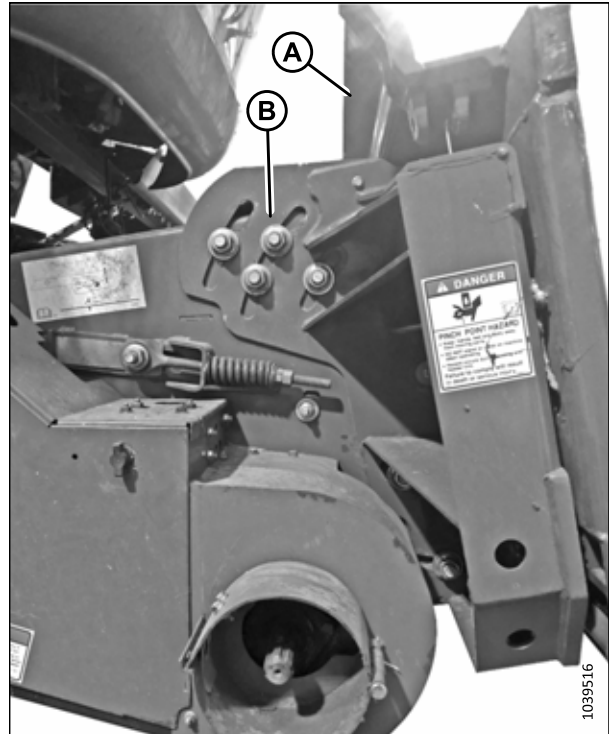
Ensure that all bystanders have cleared the area.

#### **IMPORTANT:**

If the combine is **NOT** equipped with a rock trap, feeder house faceplate (A) **MUST** be in mid-position (B). For instructions on adjusting the faceplate, refer to the combine operator's manual.

#### **NOTE:**

A rock trap prevents rocks or debris from entering the combine, and is located on the front of the combine and behind the feeder house.



**Figure 3.144: Faceplate Tilted to Mid-Position on Unspecified Combine**

1. Shut down the engine, and remove the key from the ignition.

## OPERATION

2. Push handle (A) on the combine multicoupler receptacle toward the feeder house to retract pins (B) at the bottom corners of the feeder house. Clean the receptacle.
3. Slowly drive the combine up to the header until feeder house saddle (C) is directly under float module top cross member (D).
4. Raise the feeder house slightly to lift the header, ensuring that the feeder house saddle is properly engaged in the float module frame.
5. Shut down the engine, and remove the key from the ignition.

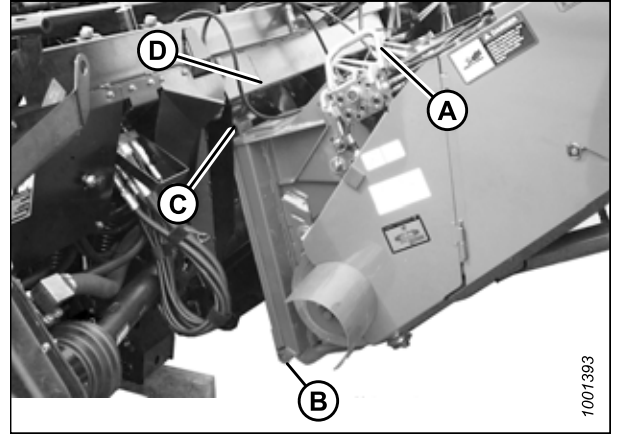


Figure 3.145: Combine and Float Module

6. Pull handle (A) on the float module to release multicoupler (B) from the storage position.
7. Remove the multicoupler, and push the handle back into the float module.

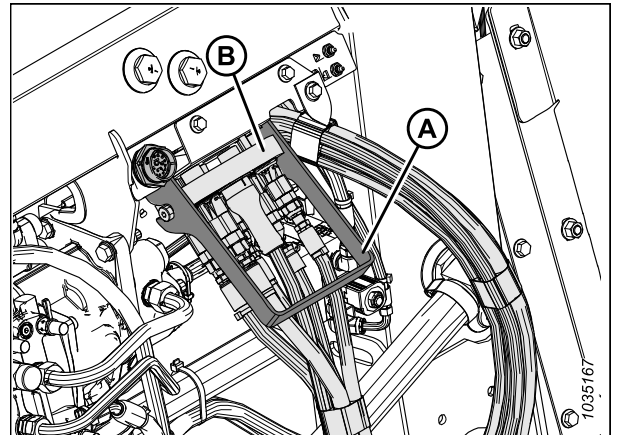


Figure 3.146: Multicoupler Storage

8. Position multicoupler (A) onto the receptacle.
9. Pull locking pin (B) and lower handle (C) until locking pin (B) is fully engaged.

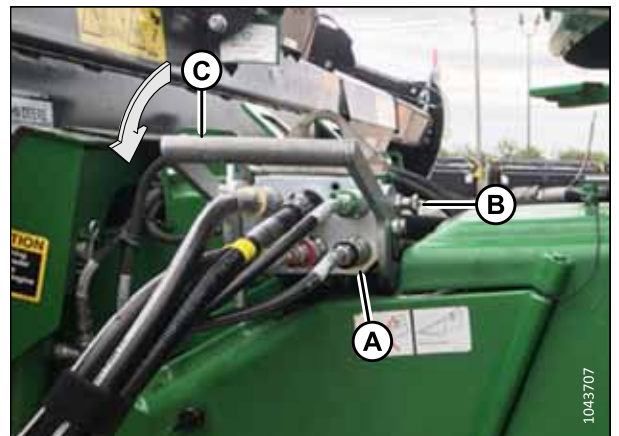
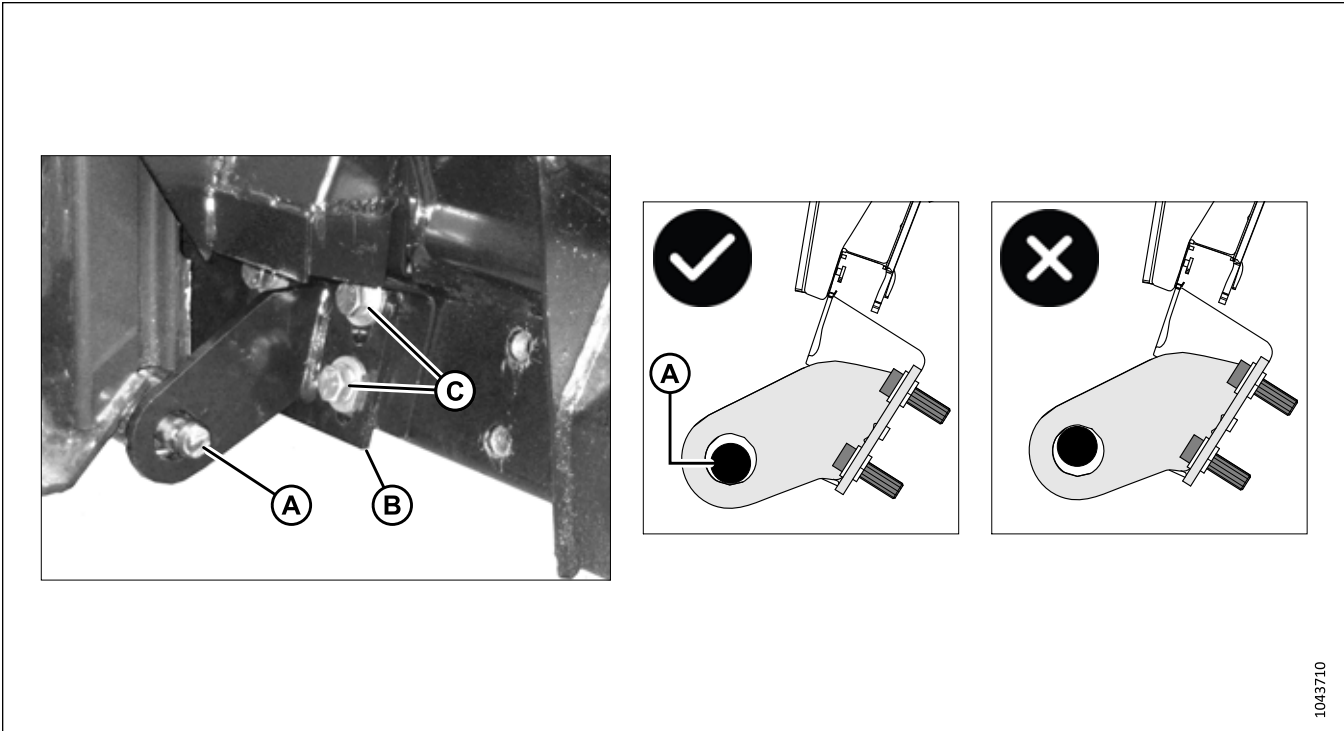


Figure 3.147: Multicoupler

## OPERATION



**Figure 3.148: Feeder House Locking Pin used on John Deere 60, 70, S, or T Series**

10. **60, 70, S, or T Series:** Ensure that both feeder house locking pins (A) are fully engaged into the float module anchor brackets (B), and sit toward the bottom of the circular cutouts of the brackets, with some clearance as shown.

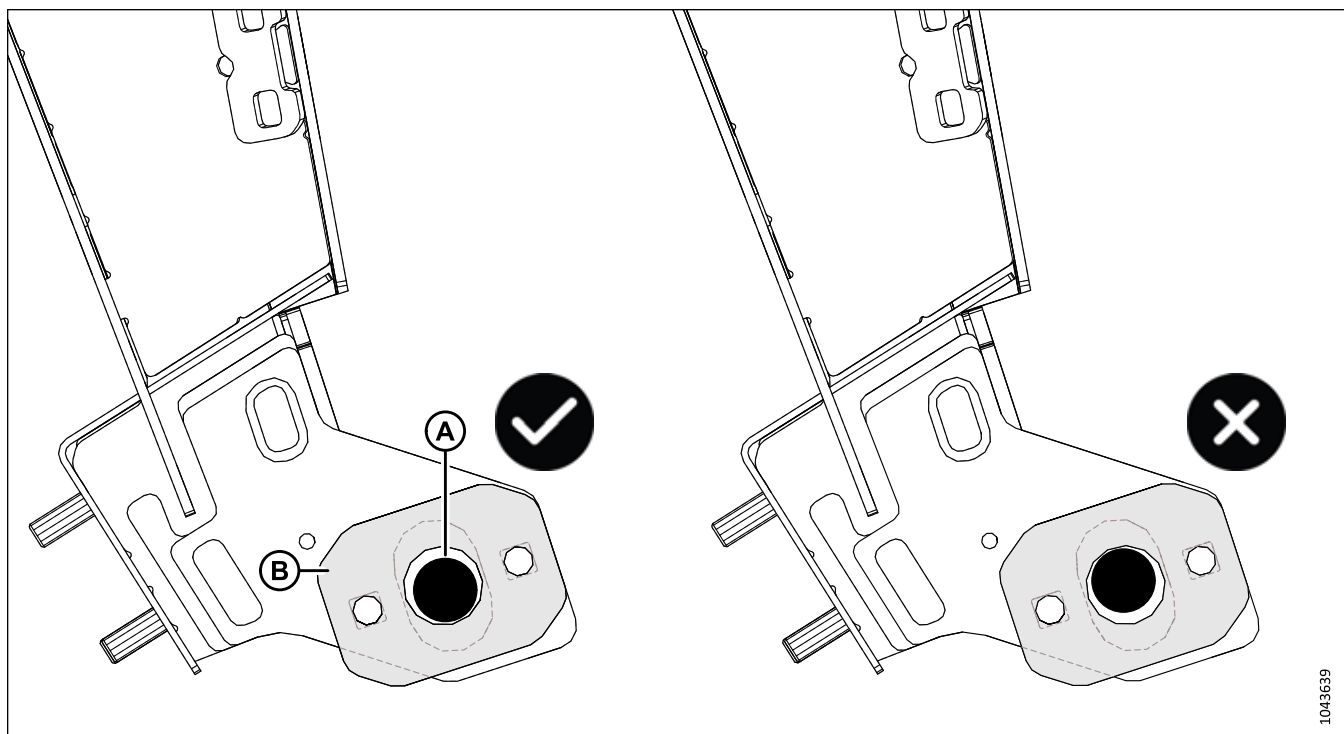
**IMPORTANT:**

The header might fall off the feeder house if pins (A) do not fully engage the anchor brackets. If pins (A) do not fully engage the brackets, first ensure that the multicoupler locking pin is fully engaged. If the problem persists, refer to the original equipment manufacturer (OEM) manual for instructions on how to adjust the feeder house locking pins outward.

**IMPORTANT:**

The pin should sit at the bottom of the circular cutout so that there is little to no ability for the frame to lift off the feeder house. To adjust an anchor bracket, loosen bolts (C), re-position the bracket as required, and re-tighten bolts (C) to 75 Nm (55 lbf-ft).





**Figure 3.149: John Deere X9 Feeder House Locking Pin Alignment – Single-Position Adjustment Plate**

11. **X9 Series:** Ensure that both feeder house locking pins (A) are fully engaged into the float module anchor brackets, and sit toward the bottom of the circular cutout in adjustment plates (B) with some clearance as shown.

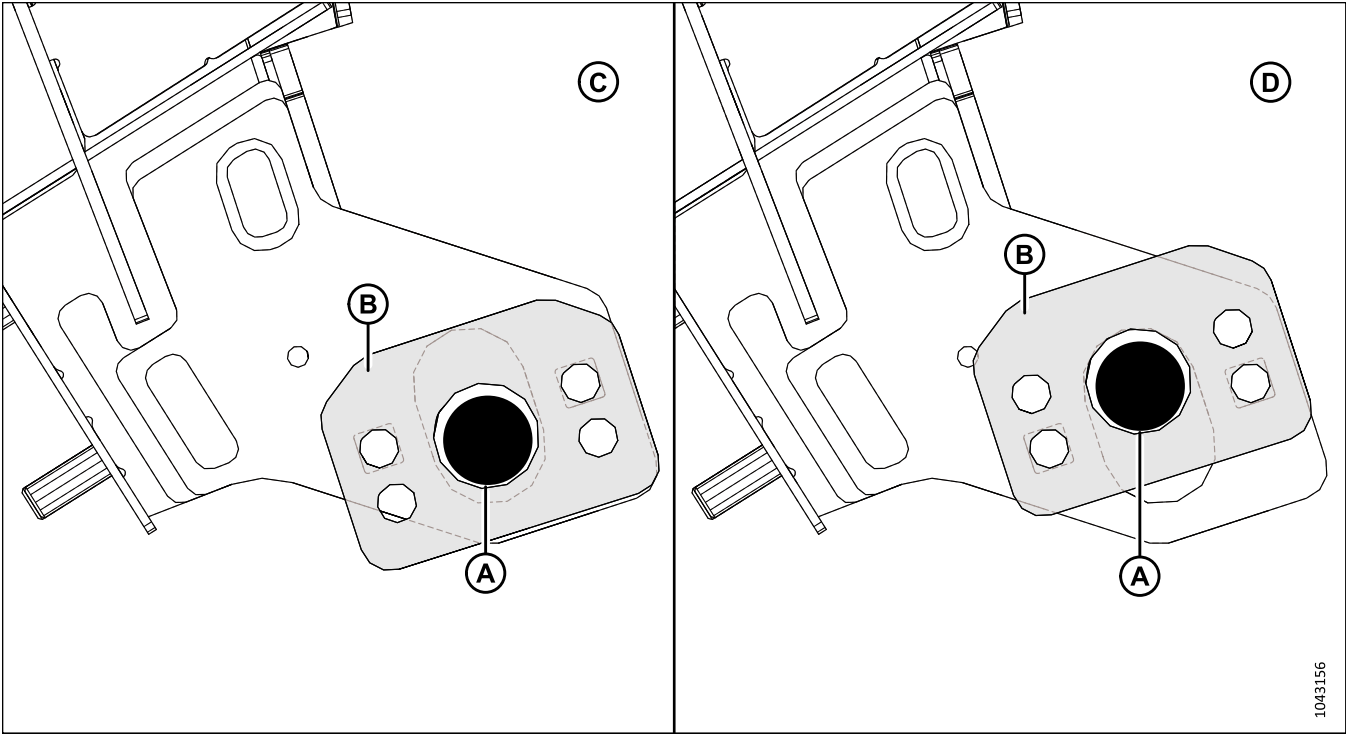
**IMPORTANT:**

The header might fall off the feeder house if pins (A) do not fully engage the anchor brackets. If pins (A) do not fully engage the brackets, first ensure that the multicoupler locking pin is fully engaged. If the problem persists, refer to the original equipment manufacturer (OEM) manual for instructions on how to adjust the feeder house locking pins outward.

**IMPORTANT:**

The pin should sit at the bottom of the circular cutout so that there is little to no ability for the frame to lift off the feeder house. Single-position adjustment plates (with only one set of mounting holes) are shown in [Figure 3.149, page 115](#). If the ideal locking pin alignment cannot be achieved using the single-position plates, then position two-position adjustment plates (with two sets of mounting holes), according to [Figure 3.150, page 116](#) or [Figure 3.151, page 116](#). All adjustment plates and their mounting nuts **MUST** be on the outboard side of the transition frame anchor plates.

OPERATION



1043156

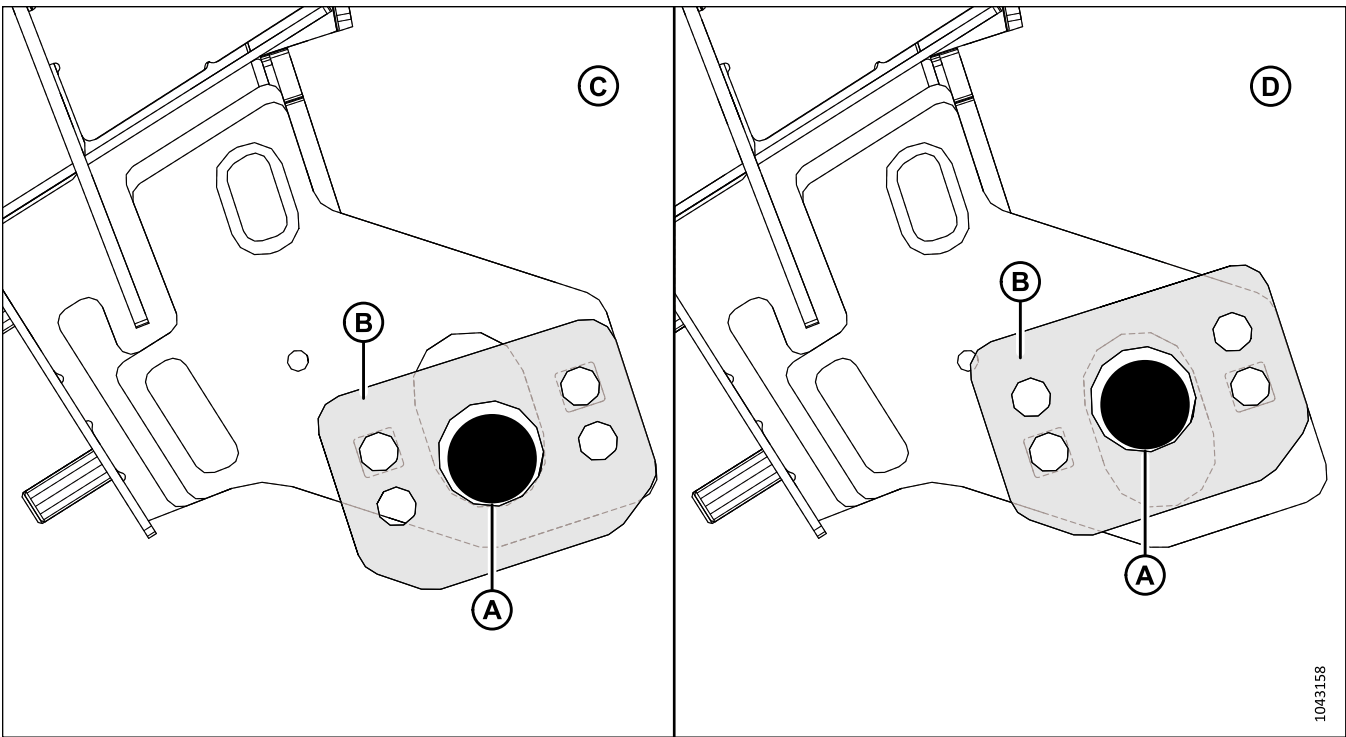
Figure 3.150: X9 Series Two-Position Adjustment Plate, Side A

A – Combine Locking Pin

B – Two-Position Locking Plate

C – Position 1

D – Position 2



1043158

Figure 3.151: X9 Series Two-Position Adjustment Plate, Side B

A – Combine Locking Pin

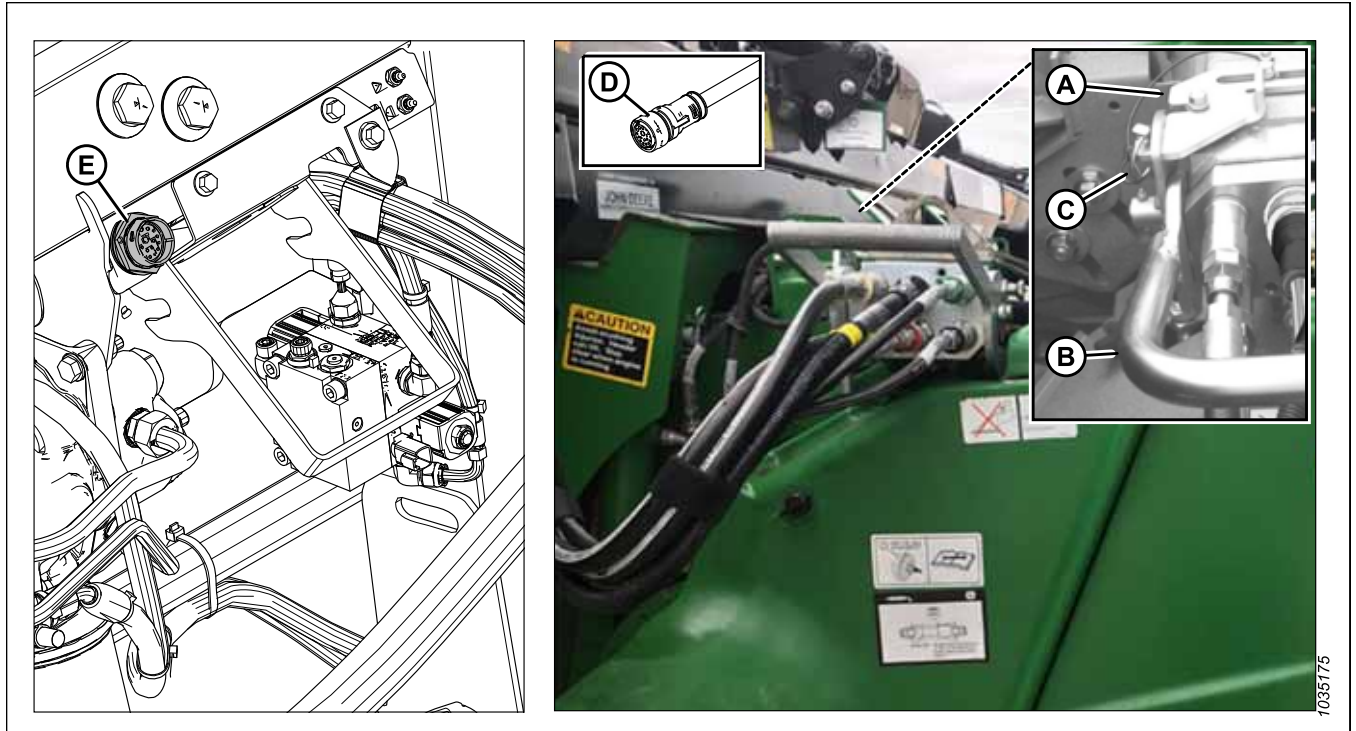
B – Two-Position Locking Plate

C – Position 1

D – Position 2



## OPERATION



**Figure 3.152: Multicoupler Lock, Electrical Connections**

12. Slide latch (A) to lock handle (B) in position and secure it with lynch pin (C).
13. **60, 70, S, or T Series:** Remove cab control kit connector C81A (D) from its storage location on the combine and connect it to receptacle C81B (E) on the float module. Turn the collar on the connector to lock it in place.

## OPERATION

14. Pull driveline collar (A) back to release the driveline from support bracket (B). Remove the driveline from the support bracket.

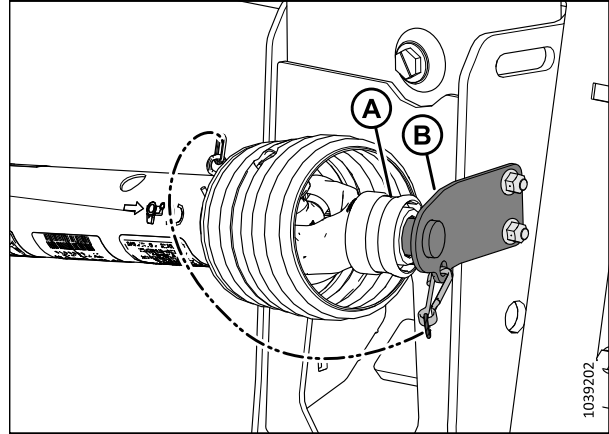


Figure 3.153: Driveline in Storage Position – Driveline B7038 or B7039

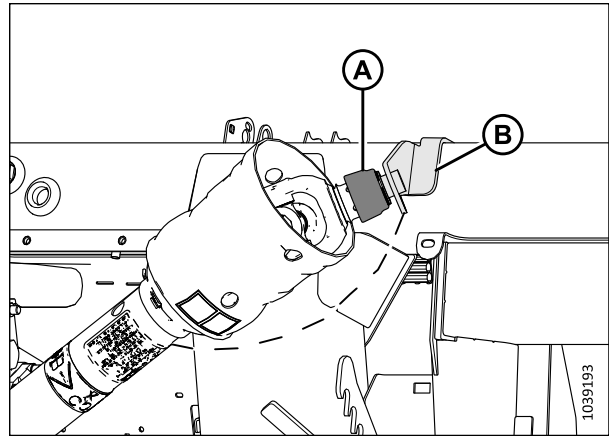


Figure 3.154: Driveline in Storage Position – Sidehill/Hillside Driveline B7326 or B7182

15. Pull back collar (A) on the end of the driveline, and push the driveline onto combine output shaft (B) until the collar locks.

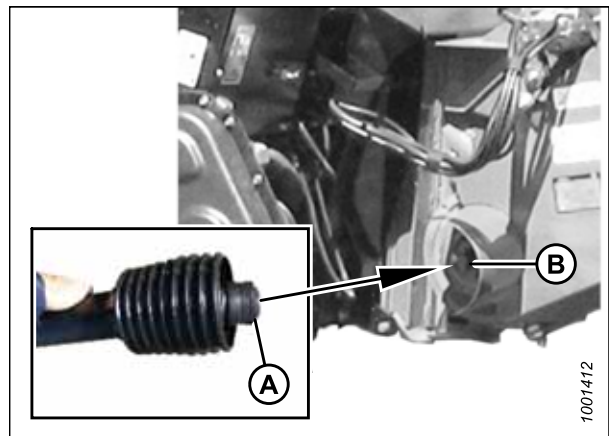


Figure 3.155: Driveline

## OPERATION

16. Disengage the float locks by pulling each float lock handle (A) away from the float module, and setting it in unlocked position (B).

### NOTE:

The illustration shows the float lock handle on the right side of the header; the float lock handle on the left side of the header is the opposite.

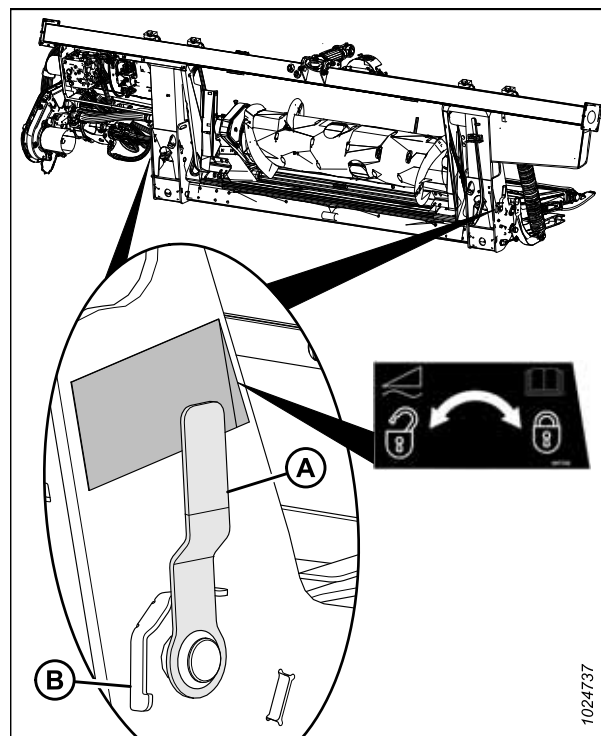


Figure 3.156: Float Lock Handle

### Detaching Header from John Deere Combine

The header will need to be physically disconnected from the combine, and the hydraulic and electrical connections will need to be removed.

#### **DANGER**

To prevent bodily injury or death from the unexpected start-up or fall of a raised machine, always stop the engine, remove the key, and engage the safety props before going under the header for any reason.

#### **DANGER**

Ensure that all bystanders have cleared the area.

1. Choose a level area and position the header slightly above the ground.
2. Shut down the engine, and remove the key from the ignition.

#### **IMPORTANT:**

If transport wheels are installed, set the wheels to the storage or uppermost working position. If the wheels are not in position, the header may tilt forward and make reattachment difficult. For instructions, refer to [Adjusting EasyMove™ Transport Wheels, page 191](#).

#### **IMPORTANT:**

If stabilizer wheels are installed, set the wheels to the storage or uppermost working position. If the wheels are not in position, the header may tilt forward and make reattachment difficult. For instructions, refer to [Adjusting Stabilizer Wheels, page 190](#).

## OPERATION

- Engage the float locks by pulling each float lock handle (A) away from the float module and setting it in locked position (B).

**NOTE:**

The illustration shows the float lock handle on the right side of the header. The float lock handle on the left side of the header is the opposite.

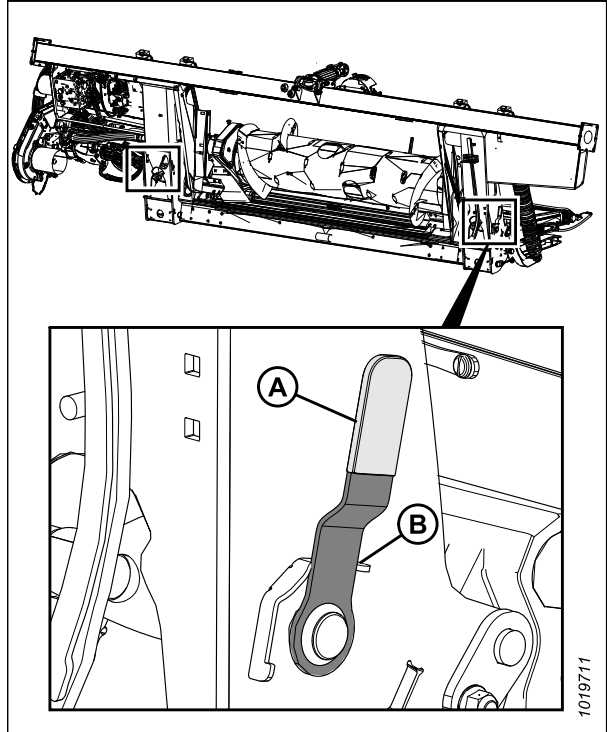


Figure 3.157: Float Lock Handle

- Open shield (A) on the combine, pull back the collar on driveline (B), and pull the driveline off the combine output shaft.

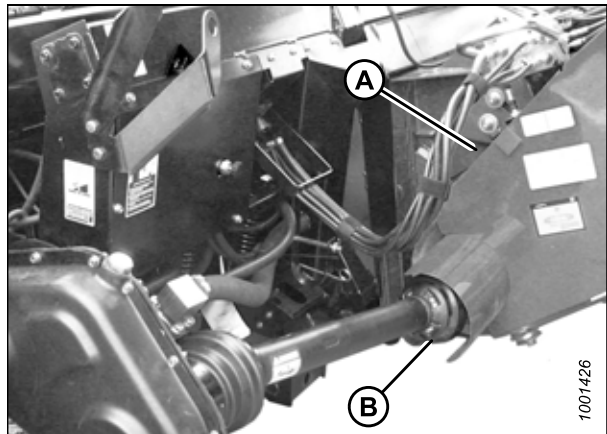


Figure 3.158: Driveline

## OPERATION

5. Store the driveline on driveline support bracket (B) by pulling back collar (A) on the driveline and fitting it onto support bracket (B). Release the collar so that it locks into place on the support bracket.

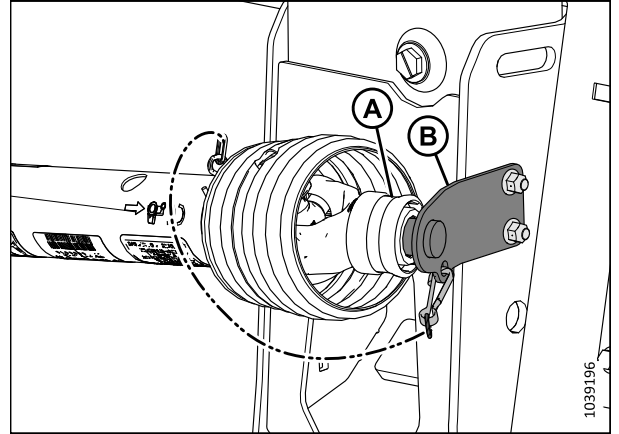


Figure 3.159: Driveline in Storage Position – Driveline B7038 or B7039

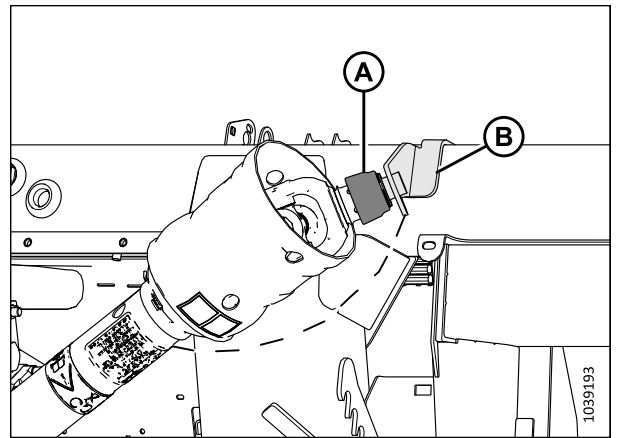


Figure 3.160: Driveline in Storage Position – Sidehill/Hillside Driveline B7326, or B7182

6. Lift handle (A) on the float module.

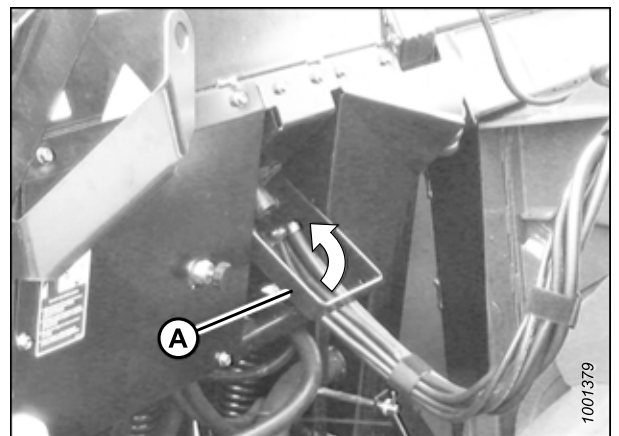


Figure 3.161: Multicoupler Storage

## OPERATION

7. Disconnect harness (A) from the combine connector.
8. Remove lynch pin (B) and slide lock (C) to release handle (D).
9. Lift handle (D) to a full vertical position to release multicoupler (E) from the combine.

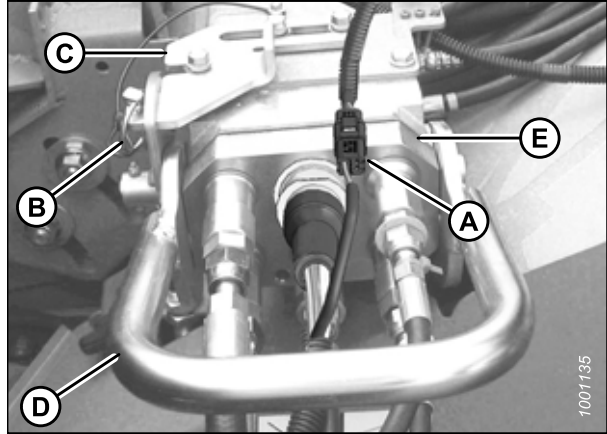


Figure 3.162: Multicoupler

10. Position multicoupler (A) on the float module receptacle and lower handle (B) to lock the multicoupler.

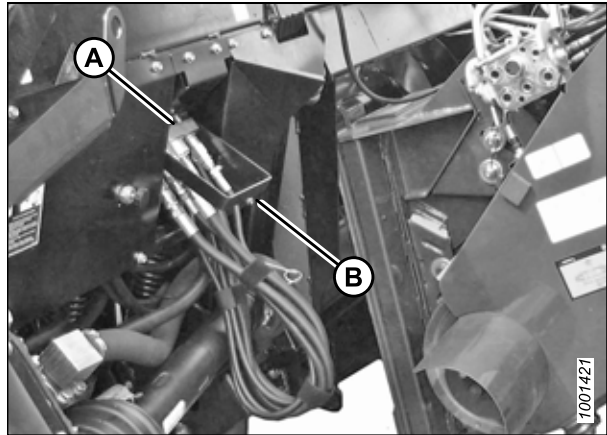


Figure 3.163: Multicoupler Storage

11. Push handle (A) on the combine toward the feeder house to disengage feeder house pin (B) from the float module.

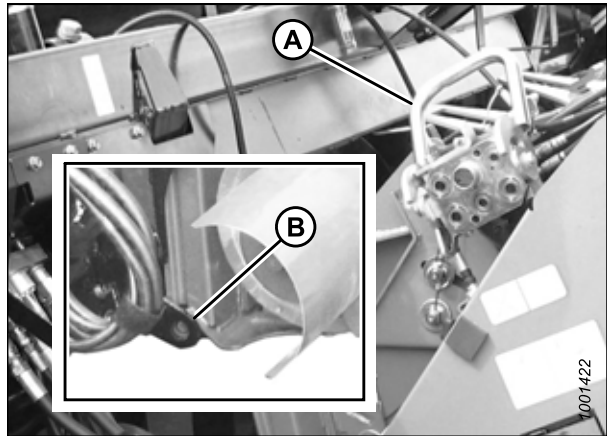


Figure 3.164: Feeder House Locks

## OPERATION

12. Lower the feeder house until saddle (A) disengages and clears float module support (B).
13. Slowly back the combine away from the float module.

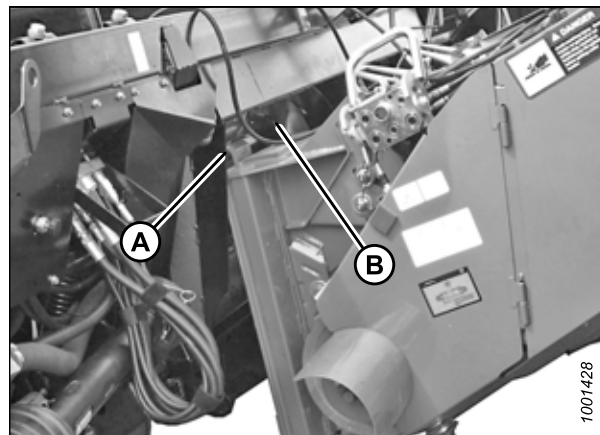


Figure 3.165: Float Module and Feeder House

### 3.6.6 New Holland Combines

To attach the header to or detach it from a New Holland combine, follow the relevant procedure in this section.

Refer to the table below for information on the New Holland combine models that are compatible with this header.

Table 3.2 New Holland Combine Compatibility

New Holland Combine Series	Combine Model
CR	920, 940, 960, 970, 980
	9020, 9040, 9060, 9065, 9070, 9080
	6090, 7090, 8080, 8090, 9090
	6.80, 6.90, 7.90, 8.90, 9.90, 10.90
CX	840, 860, 870, 880
	8070, 8080, 8090
	8080 Elevation, 8090 Elevation

#### *Attaching Header to New Holland CR, CX, or CH Combine*

The header will need to be physically connected to the combine's feeder house, and the electrical and hydraulic connections completed.

#### **DANGER**

To prevent injury or death from the unexpected start-up of the machine, always stop the engine and remove the key from the ignition before leaving the operator's seat for any reason.

#### **DANGER**

Ensure that all bystanders have cleared the area.



## OPERATION

### IMPORTANT:

If the combine is **NOT** equipped with a rock trap, feeder house faceplate (A) **MUST** be in mid-position (B). For instructions on adjusting the faceplate, refer to the combine operator's manual.

### NOTE:

A rock trap prevents rocks or debris from entering the combine, and is located on the front of the combine and behind the feeder house.

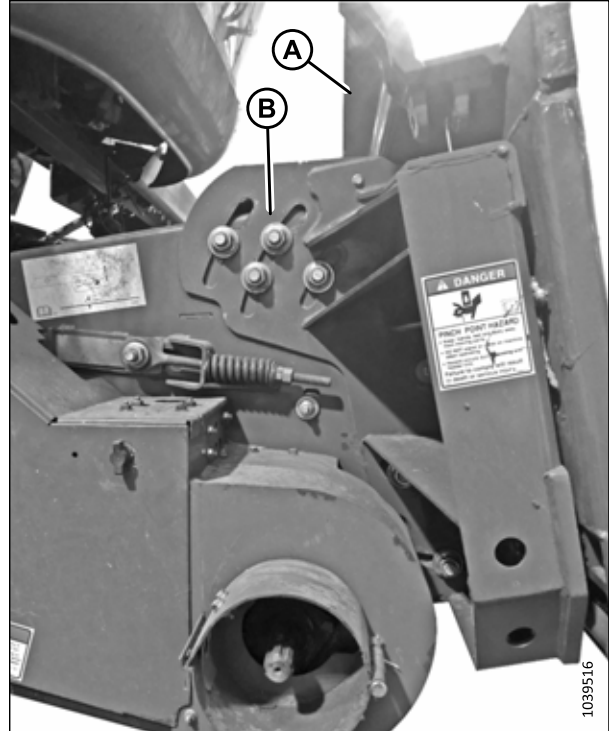


Figure 3.166: Faceplate Tilted to Mid-Position on Unspecified Combine

1. Shut down the engine, and remove the key from the ignition.
2. Ensure that handle (A) is positioned so that locks (B) can engage the float module.

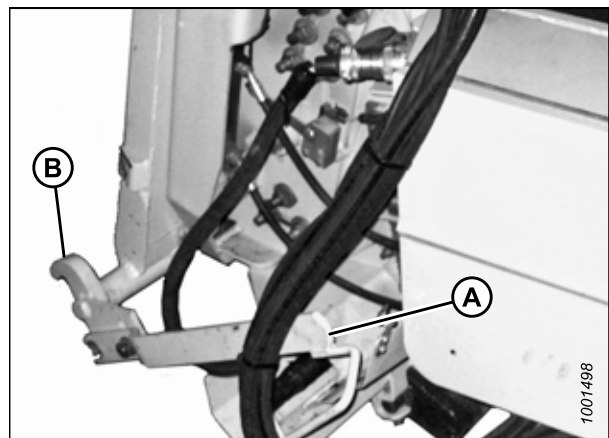


Figure 3.167: Feeder House Locks



## OPERATION

3. Slowly drive the combine up to the float module until feeder house saddle (A) is directly under float module top cross member (B).
4. Raise the feeder house slightly to lift the header. Ensure that the feeder saddle is fully engaged in the float module frame.
5. Shut down the engine, and remove the key from the ignition.

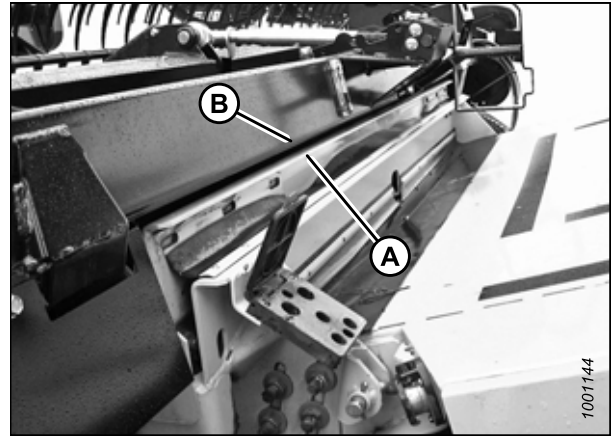


Figure 3.168: Header on Combine

6. On the left side of the feeder house, lift lever (A) on the float module, and push handle (B) on the combine to engage locks (C) on both sides of the feeder house.
7. Push down on lever (A) so the slot in the lever engages the handle and locks it in place.
8. If the lock does not fully engage pin (D) on the float module when lever (A) and handle (B) are engaged, loosen bolts (E) and adjust lock (C). Retighten the bolts.

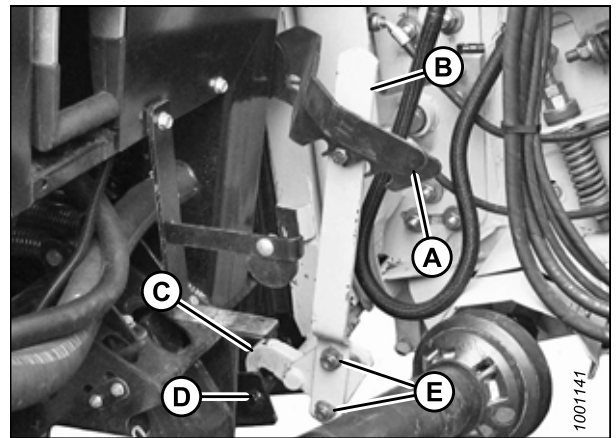
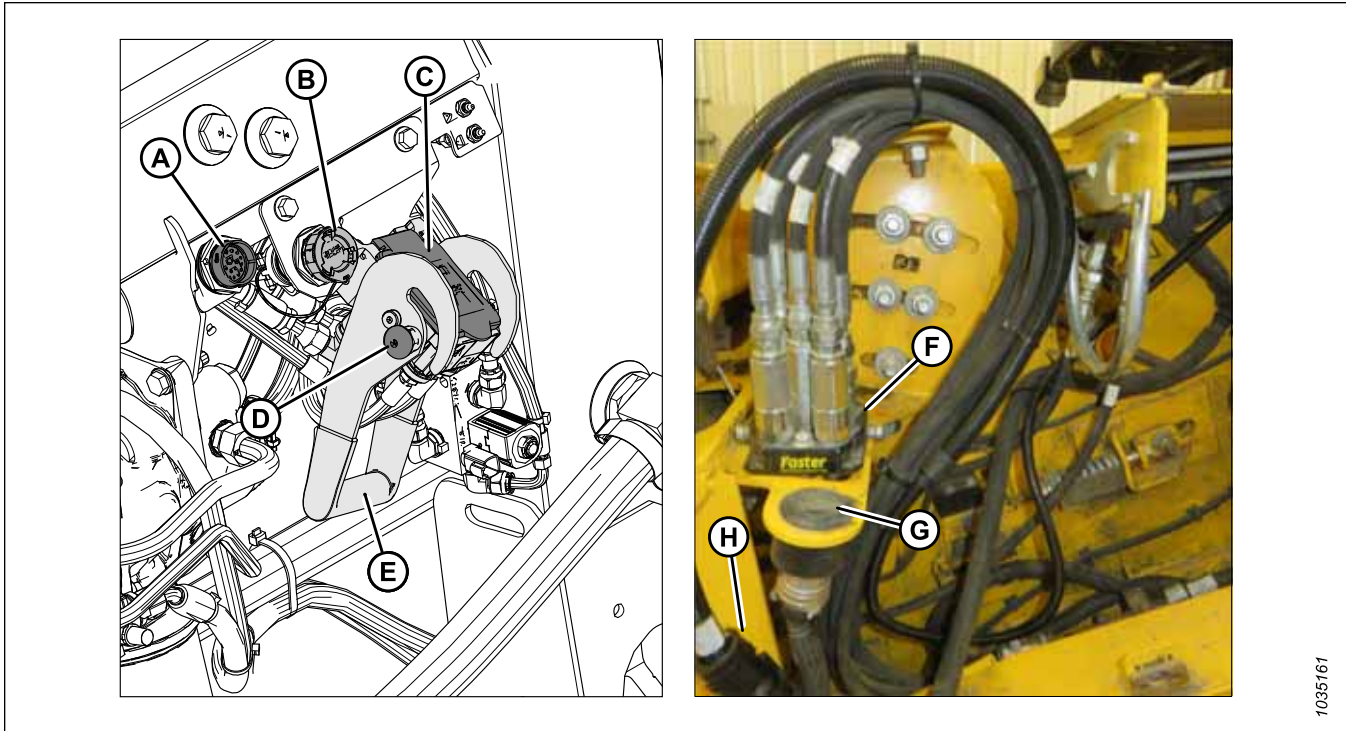


Figure 3.169: Feeder House Locks



1035161

**Figure 3.170: Multicoupler and Electrical Connections**

9. **If MacDon in-cab controls are installed:** Remove the cap from connector C81B (A).
10. Remove the cap from connector C72B (B).
11. Remove the cover from hydraulic receptacle (C). Clean the receptacle mating surfaces.
12. Push in lock button (D) and pull handle (E) to the fully open position.
13. Remove hydraulic quick coupler (F) from the storage plate on the combine. Clean the mating surface of the coupler.
14. Position coupler (F) onto float module receptacle (C).
15. Push handle (E) to the closed position until lock button (D) snaps out.
16. Remove combine connector (G) from its storage location on the combine and connect it to receptacle C72B (B). Turn the collar on the connector to lock it in place.
17. **If MacDon in-cab controls are installed:** Remove cab control kit connector C81A (H) from its storage location on the combine and connect it to receptacle C81B (A). Turn the collar on the connector to lock it in place.

## OPERATION

18. Pull driveline collar (A) back to release the driveline from the support bracket (B). Remove the driveline from the support bracket.

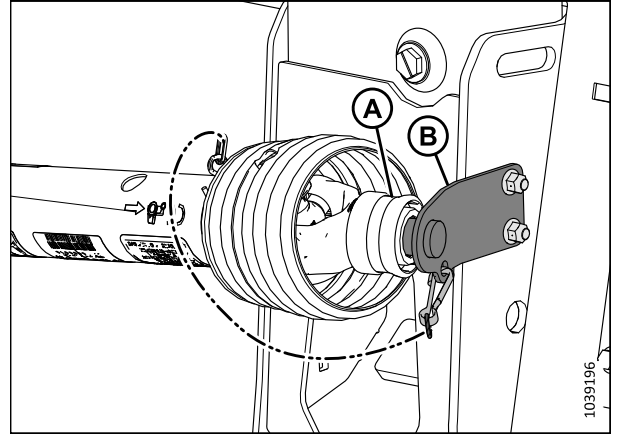


Figure 3.171: Driveline in Storage Position – Driveline B7038 or B7039

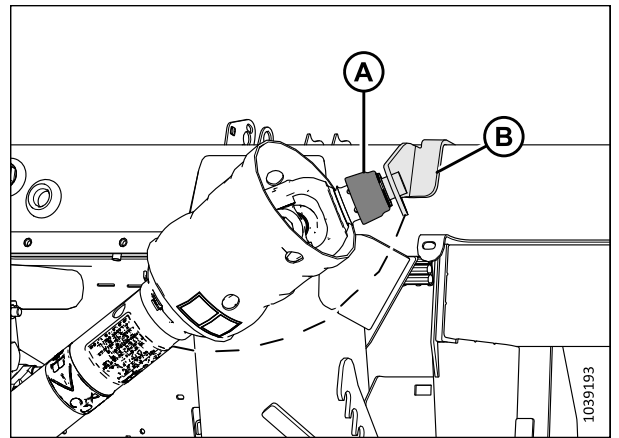


Figure 3.172: Driveline in Storage Position – Sidehill/Hillside Driveline B7180, B7181, or B7326

19. Pull back the collar on the end of the driveline, and push the driveline onto combine output shaft (A) until the collar locks.

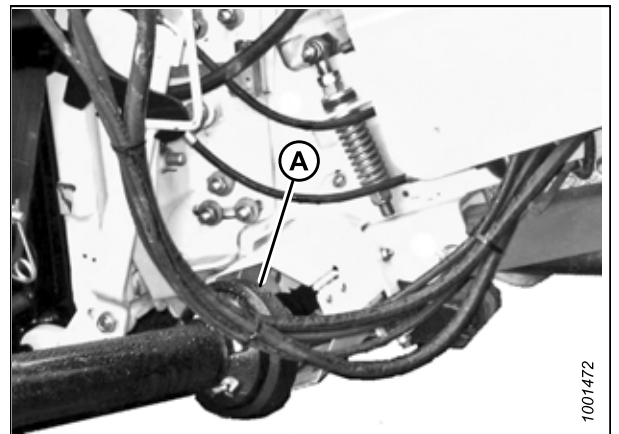


Figure 3.173: Driveline and Output Shaft

## OPERATION

20. Proceed as follows:

- If the header is going to be used in the field now, disengage the float locks by pulling each float lock handle (A) away from the float module and into unlocked position (B).
- If the header is **NOT** going to be used in the field now, engage the float locks by pushing each float lock handle (A) toward the float module and into locked position (C).

### NOTE:

The illustration shows the float lock handle on the right side of the header. The float lock handle on the left side of the header is the opposite.

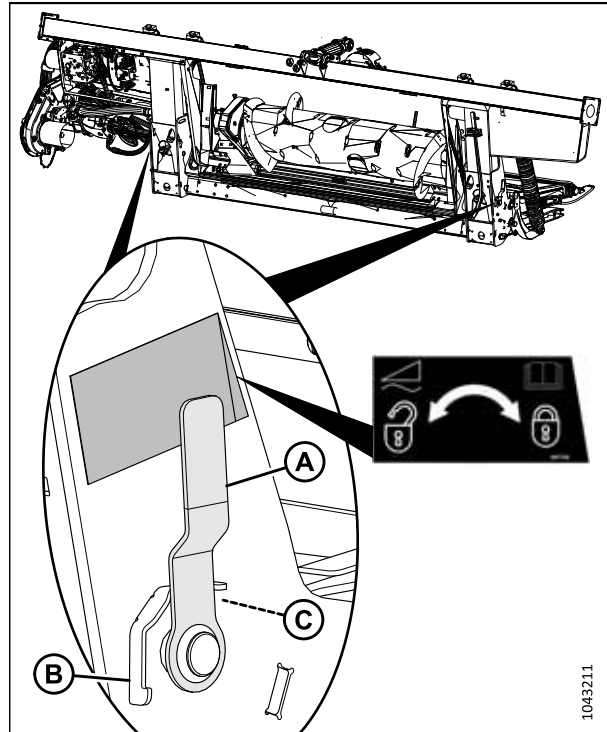


Figure 3.174: Float Lock Handle

### Detaching Header from New Holland CR, CX, or CH Combine

The header will need to be physically disconnected from the combine, and the hydraulic and electrical connections will need to be removed.

### DANGER

To prevent injury or death from the unexpected start-up of the machine, always stop the engine and remove the key from the ignition before leaving the operator's seat for any reason.

### DANGER

Ensure that all bystanders have cleared the area.

1. Choose a level area and position the header slightly above the ground.
2. Shut down the engine, and remove the key from the ignition.

### IMPORTANT:

If transport wheels are installed, set the wheels to the storage or uppermost working position. If the wheels are not in position, the header may tilt forward, and make reattachment difficult. For instructions, refer to [Adjusting EasyMove™ Transport Wheels, page 191](#).

### IMPORTANT:

If stabilizer wheels are installed, set the wheels to the storage or uppermost working position. If the wheels are not in position, the header may tilt forward, and make reattachment difficult. For instructions, refer to [Adjusting Stabilizer Wheels, page 190](#).

## OPERATION

- Engage the float locks by pulling each float lock handle (A) away from the float module and setting it in locked position (B).

**NOTE:**

The illustration shows the float lock handle on right side of the header. The float lock handle on the left side of the header is the opposite.

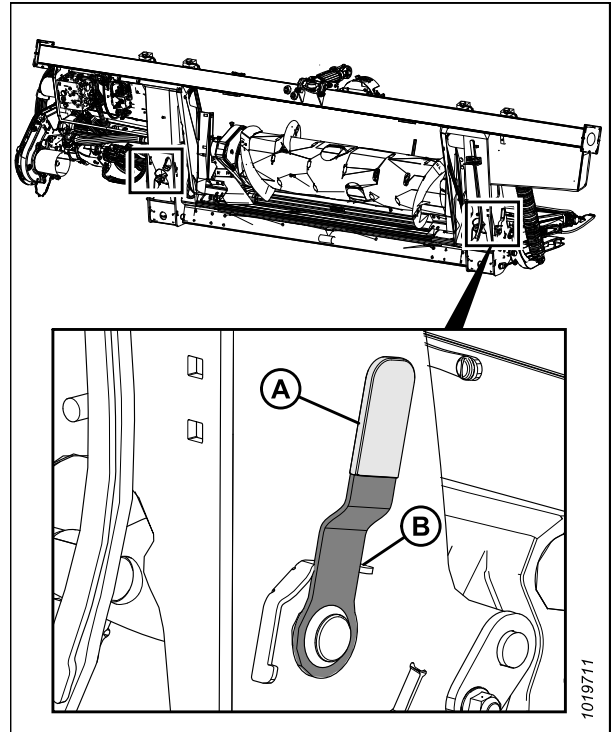


Figure 3.175: Float Lock Handle

- Disconnect the driveline from the combine. Push back the collar on the end of the driveline and pull the driveline out of combine output shaft (A) until the collar disengages.

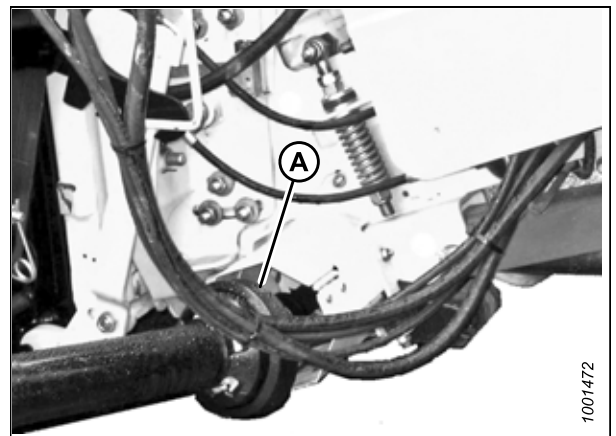


Figure 3.176: Driveline

## OPERATION

5. Store the driveline on driveline support bracket (B) by pulling back collar (A) on the driveline and fitting it onto support bracket (B). Release the collar so it locks into place on the bracket.

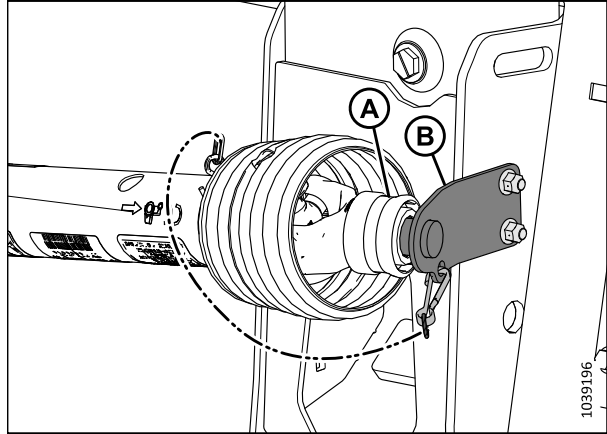


Figure 3.177: Driveline in Storage Position – Driveline B7038 or B7039

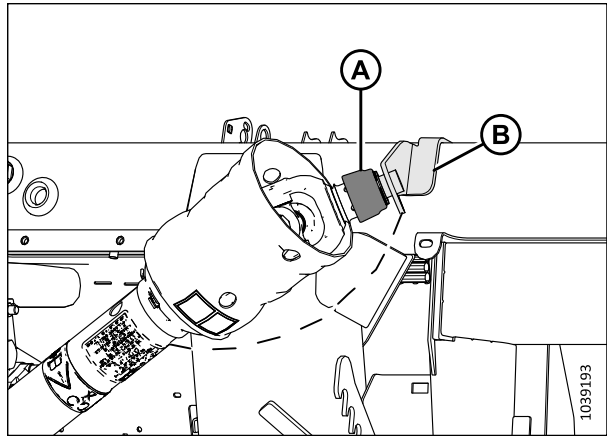


Figure 3.178: Driveline in Storage Position – Sidehill/Hillside Driveline B7180, B7181, or B7326

6. Push in lock button (B), and pull handle (C) to release multicoupler (A).

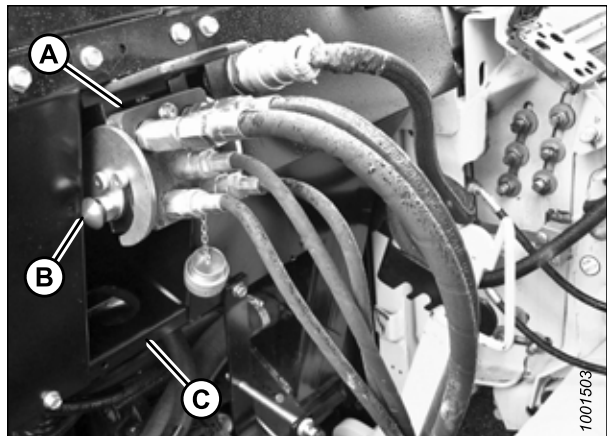


Figure 3.179: Float Module Connections



## OPERATION

7. Push handle (A) to the closed position until lock button (B) snaps out. Close the cover.

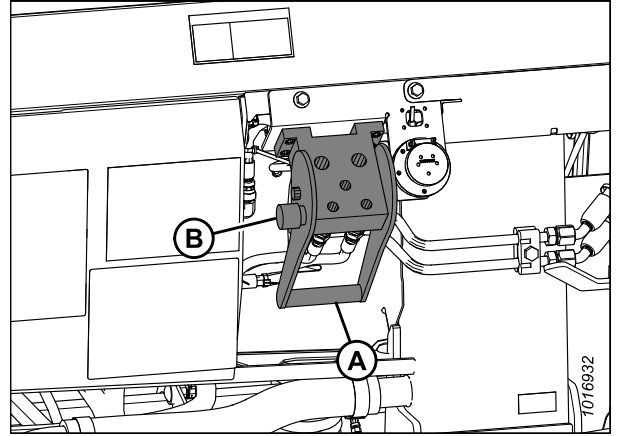


Figure 3.180: Float Module Receptacles

8. Position hydraulic quick coupler (A) onto storage plate (B) on the combine.

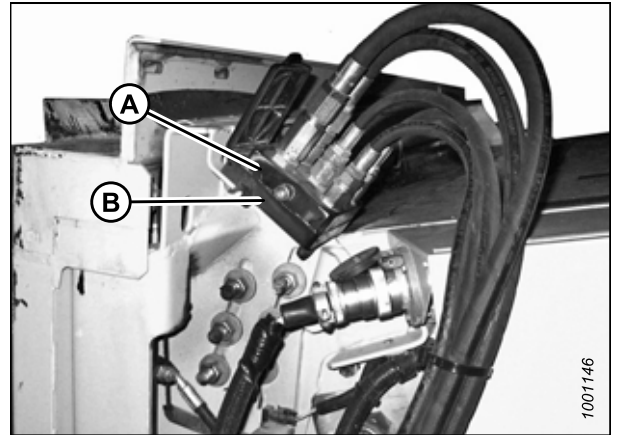


Figure 3.181: Combine Coupler

9. Remove electrical connector (A) from the float module.

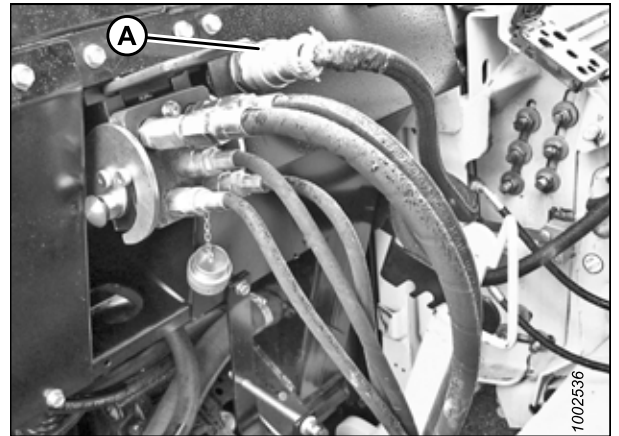


Figure 3.182: Float Module Connections

## OPERATION

10. Connect the electrical connector to the combine at location (A).

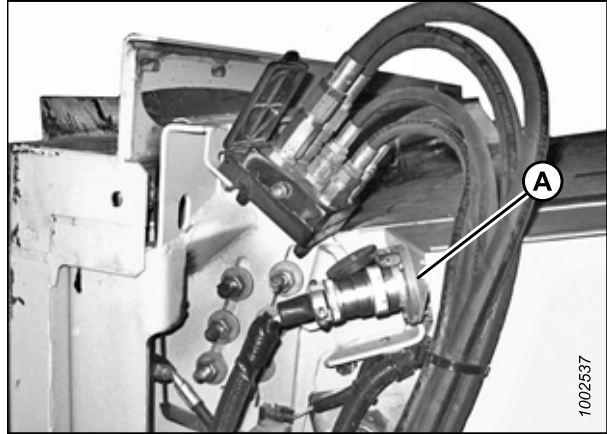


Figure 3.183: Combine Couplers

11. Replace cover (A) on the float module receptacle.

**NOTE:**

If MacDon in-cab controls are installed, disconnect cab control connector C81A from receptacle C81B and secure the connector to its storage location on the combine.

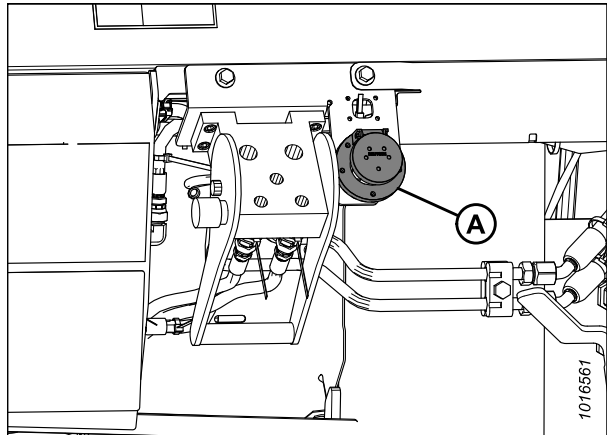


Figure 3.184: Float Module Receptacles

12. Lift lever (A) and pull and lower handle (B) to disengage feeder house/float module lock (C).

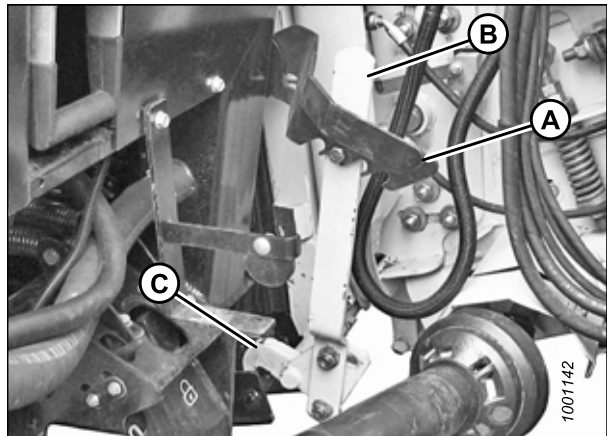


Figure 3.185: Feeder House Locks



## OPERATION

13. Lower feeder house (A) until the feeder house disengages float module support (B).
14. Back the combine slowly away from the header.

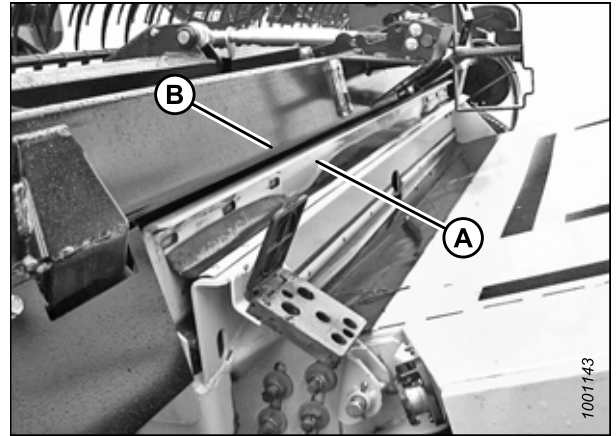


Figure 3.186: Header on Combine

### 3.6.7 Rostselmash Combines

To attach or detach the header to or from a Rostselmash combine, follow the relevant procedure in this section.

The following Rostselmash combine models are compatible with this header:

- RSM 161
- Torum 785
- T500

#### NOTE:

To complete the FM200 conversion, extra bundles are required. Transition frame conversion kit B7311 will be required for all Rostselmash combines and driveshaft conversion kit B7312 will be required for Rostselmash combines 2019 and older.

#### *Attaching Header to Rostselmash Combine*

The header will need to be physically connected to the combine's feeder house, and the electrical and hydraulic connections completed.

#### **DANGER**

To prevent injury or death from the unexpected start-up of the machine, always stop the engine and remove the key from the ignition before leaving the operator's seat for any reason.

#### **DANGER**

Ensure that all bystanders have cleared the area.

## OPERATION

### IMPORTANT:

If the combine is **NOT** equipped with a rock trap, feeder house faceplate (A) **MUST** be in mid-position (B). For instructions on adjusting the faceplate, refer to the combine operator's manual.

### NOTE:

A rock trap prevents rocks or debris from entering the combine, and is located on the front of the combine and behind the feeder house.

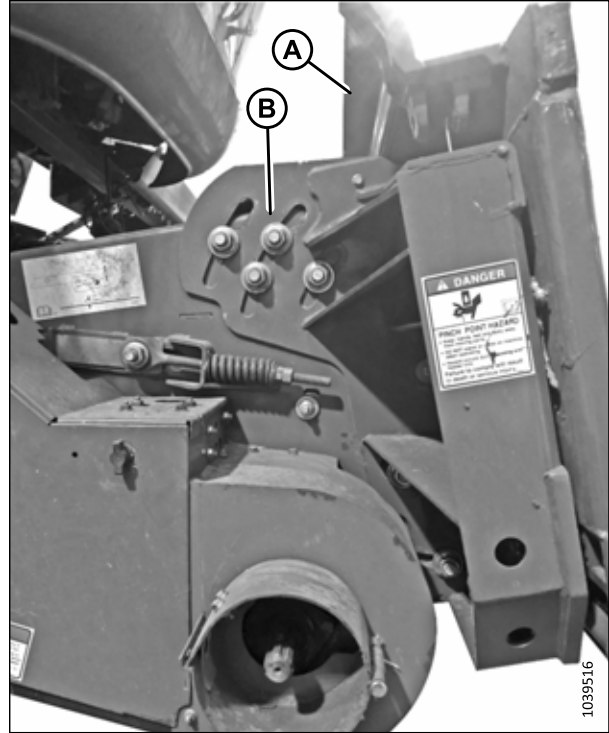


Figure 3.187: Faceplate Tilted to Mid-Position on Unspecified Combine

1. Slowly drive the combine up to the header until feeder house saddle (A) is directly under float module top cross member (B).
2. Raise the feeder house slightly to lift the header, ensuring the feeder house saddle is properly engaged in the float module frame.
3. Shut down the engine, and remove the key from the ignition.

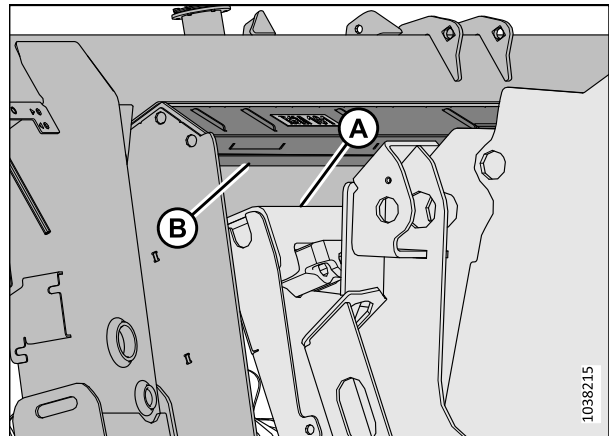


Figure 3.188: Combine and Float Module

## OPERATION

4. Pull pin (A) outward and rotate handle (B) until both feeder house pins (C) are fully engaged into float module brackets (D).

**NOTE:**

If pins (C) do not fully engage the float module brackets, loosen bolts (E) and adjust brackets (D) as required.

5. Tighten nuts (E).

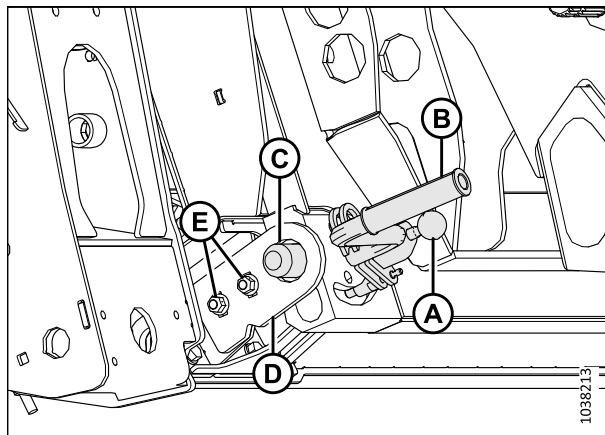


Figure 3.189: Feeder House Pin

6. Push in lock button (A) and pull handle (B) to the fully open position.
7. Remove the hydraulic quick coupler from the storage plate on the combine. Clean the mating surface of the coupler.
8. Position the combine coupler onto the float module receptacle. Push down on the handle to engage the pins into the receptacle.
9. Push the handle down to the closed position until lock button (B) snaps out.
10. Remove the combine connector from the storage location on the combine and connect it to receptacle (C). Turn the collar on the connector to lock it in place.
11. Remove the cab control kit connector C81A from the storage location on the combine and connect it to connector C81B (D). Turn the collar on the connector to lock it.

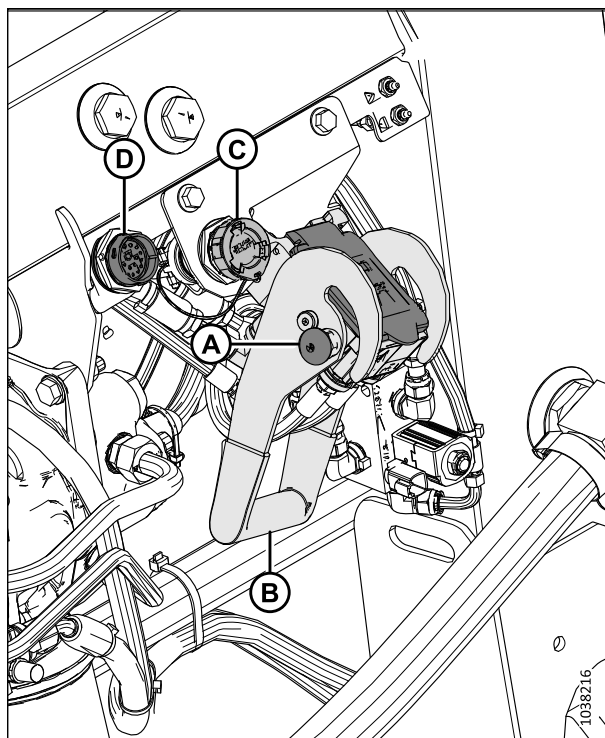


Figure 3.190: Multicoupler Storage

## OPERATION

12. Detach safety chain (C) from support bracket (B).
13. Pull driveline collar (A) back to release the driveline from the support bracket. Remove the driveline from the support bracket.

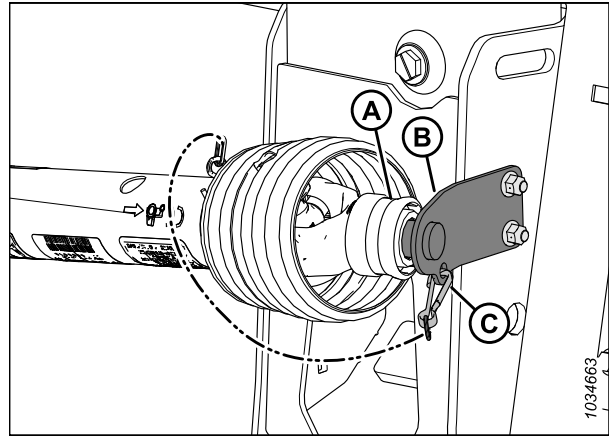


Figure 3.191: Driveline in Storage Position

14. Pull back collar (A) on the end of the driveline, and push the driveline onto combine output shaft (B) until the collar locks.

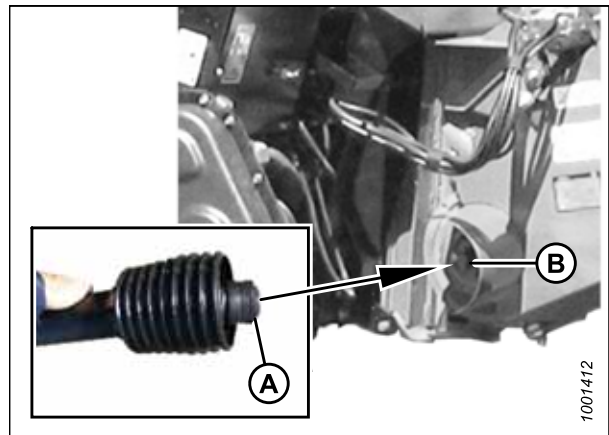


Figure 3.192: Driveline

## OPERATION

15. Proceed as follows:

- If the header is going to be used in the field now, disengage the float locks by pulling each float lock handle (A) away from the float module and into unlocked position (B).
- If the header is **NOT** going to be used in the field now, engage the float locks by pushing each float lock handle (A) toward the float module and into locked position (C).

### NOTE:

The illustration shows the float lock handle on the right side of the header. The float lock handle on the left side of the header is the opposite.

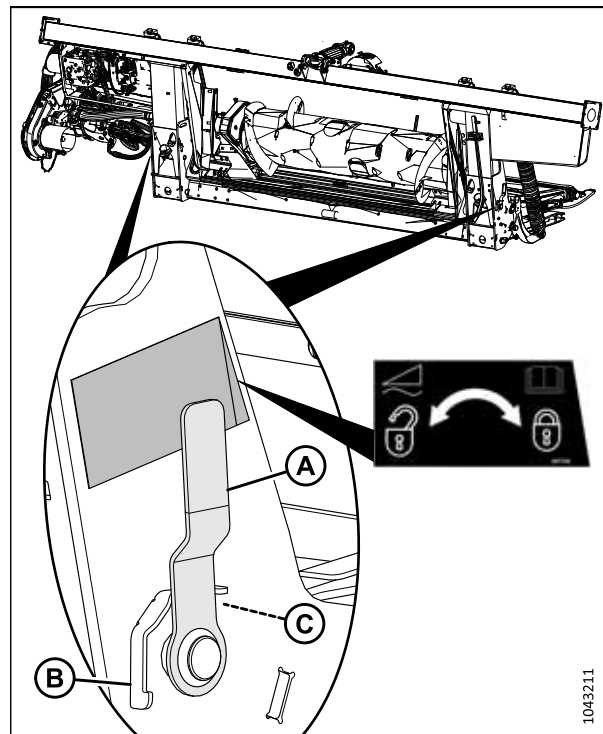


Figure 3.193: Float Lock Handle

### Detaching Header from Rostselmash Combine

The header will need to be physically disconnected from the combine, and the hydraulic and electrical connections removed.

### DANGER

To prevent injury or death from the unexpected start-up of the machine, always stop the engine and remove the key from the ignition before leaving the operator's seat for any reason.

### DANGER

Ensure that all bystanders have cleared the area.

1. Start the engine.
2. Park the combine on a level surface.
3. Position the header slightly above the ground.
4. Shut down the engine, and remove the key from the ignition.

### IMPORTANT:

If transport wheels are installed, set the wheels to the storage or uppermost working position. If the wheels are not in position, the header may tilt forward and make reattachment difficult. For instructions, refer to [Adjusting EasyMove™ Transport Wheels, page 191](#).

### IMPORTANT:

If stabilizer wheels are installed, set the wheels to the storage or uppermost working position. If the wheels are not in position, the header may tilt forward and make reattachment difficult. For instructions, refer to [Adjusting Stabilizer Wheels, page 190](#).

## OPERATION

- Engage the float locks by pulling each float lock handle (A) away from the float module and setting it in locked position (B).

**NOTE:**

The illustration shows the float lock handle on the right side of the header. The float lock on the left side of the header is the opposite.

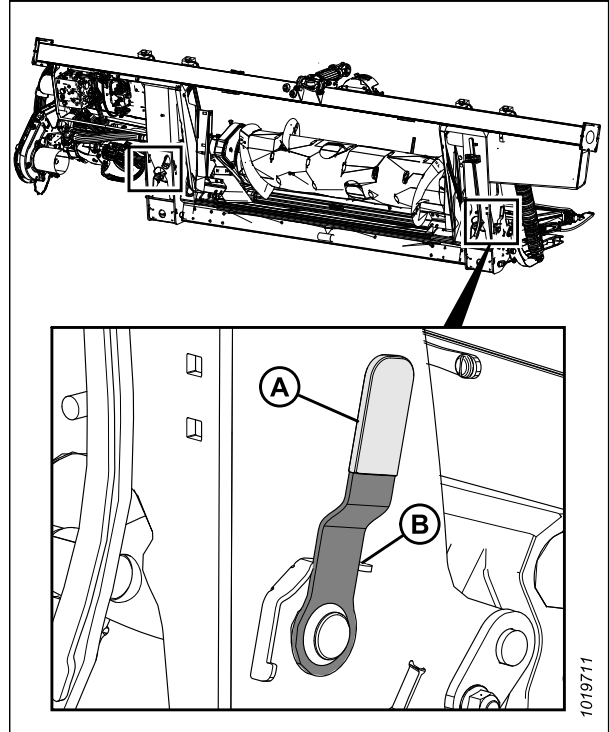


Figure 3.194: Float Lock Handle

- Disconnect combine cab control harness connector C81A from connector C81B (D).
- Disconnect the combine electrical harness from connector (C).
- Push in lock button (A) and lift handle (B) to release the multicoupler.
- Remove the hydraulic quick coupler from the combine and return to its storage location on the combine.

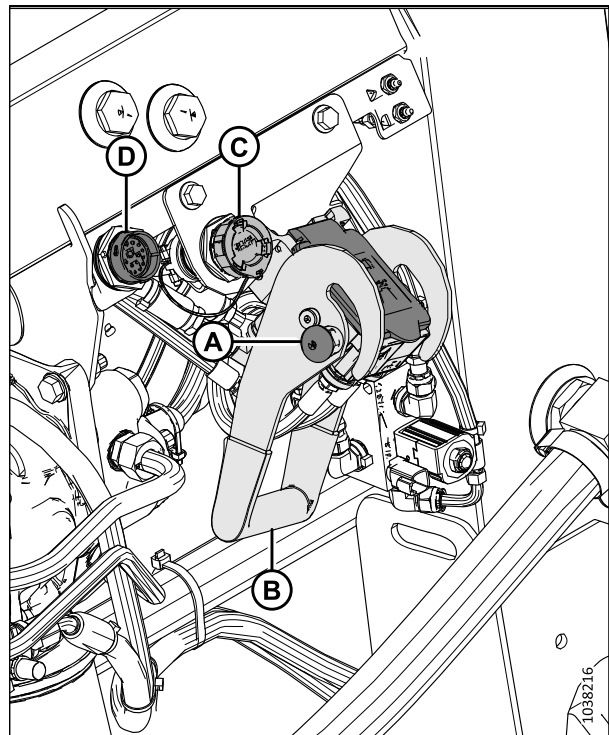


Figure 3.195: Float Lock Handle

## OPERATION

10. Pull back collar (A) on the end of the driveline, and pull the driveline out of combine output shaft (B) until the collar disengages.

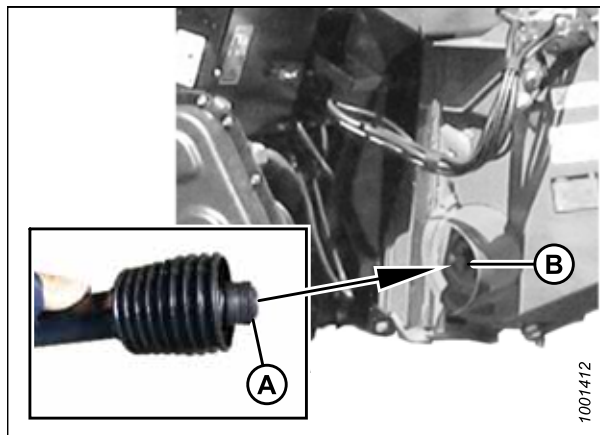


Figure 3.196: Driveline

11. Store the driveline on driveline support bracket (B) by pulling back collar (A) on the driveline and fitting it onto support bracket (B). Release the collar so it locks into place on the support bracket.
12. Attach safety chain (C) to support bracket (B).

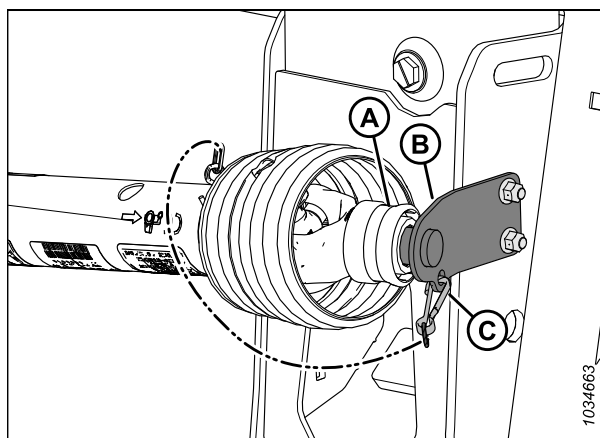


Figure 3.197: Driveline in Storage Position – Driveline B7038 or B7039

13. Pull pin (A) outward and rotate handle (B) clockwise until both feeder house pins (C) are fully retracted into float module brackets (D).

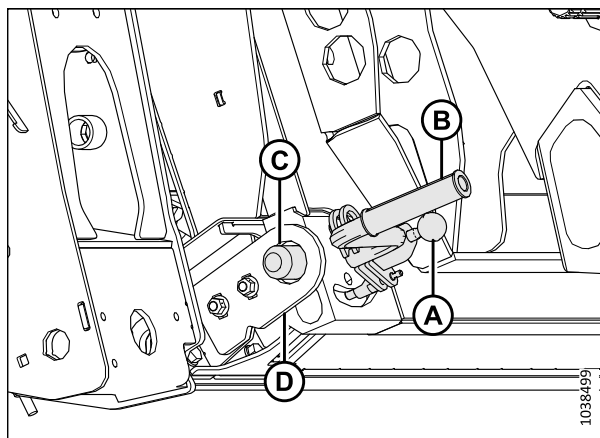


Figure 3.198: Feeder House Pin

## OPERATION

14. Start the engine.
15. Lower feeder house (A) until it disengages float module support (B).
16. Back the combine away slowly from the float module.

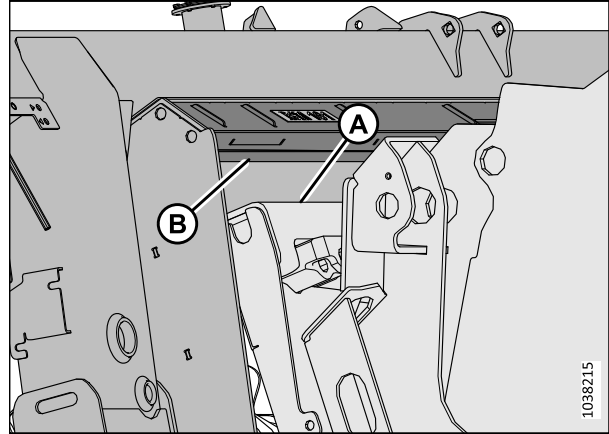


Figure 3.199: Combine and Float Module



## 3.7 Header Setup

For optimal performance, the header must be configured specifically for various harvesting conditions and crops.

### 3.7.1 Header Attachments

Optional attachments can improve performance in specific conditions or add features to the header. Optional attachments can be ordered and installed by your Dealer.

Refer to Chapter *5 Options and Attachments, page 787* for the descriptions of available items.

### 3.7.2 Header Settings

The following tables provide guidelines for setting up the header for various harvesting conditions and crops.

For information on the reel settings, refer to *3.7.4 Reel Settings, page 152*.

For information on configuring the FM200 feed auger, refer to *3.8.1 FM200 Feed Auger Performance Configurations, page 158*.

**NOTE:**

Increase the side draper speed to increase performance when there is abundant crop material or when you increase the ground speed.

Table 3.3 Recommended Settings for Cereals

Stubble Height	102 mm (<4 in.)							
Stabilizer Wheels <sup>4</sup>	Storage							
Skid Shoe Position	Up or middle							
Crop Condition	Divider Rods	Draper Speed Setting <sup>5</sup>	Header Angle <sup>6,7</sup>	Reel Cam	Reel Speed % <sup>8</sup>	Reel Position	Upper Cross Auger	
Light	Off	8	B – C	3	10–15	6 or 7	Not required	
Normal	On	7	B – C	2	10	6 or 7	Not required	
Heavy	On	7	B – C	2	10	6 or 7	Recommended	
Lodged	Off	7	B – C	3 or 4	5–10	4 or 5	Not required	
Stubble Height	102–203 mm (4–8 in.)							
Stabilizer Wheels	As needed							
Skid Shoe Position	Down for lodged crop conditions, middle or down for other crop conditions							
Crop Condition	Divider Rods	Draper Speed Setting <sup>5</sup>	Header Angle <sup>6,7</sup>	Reel Cam	Reel Speed % <sup>8</sup>	Reel Position	Upper Cross Auger	
Light	Off	8	B – C	4	10–15	6 or 7	Not required	
Normal	On	7	A	2	10	6 or 7	Not required	
Heavy	On	7	A	2	10	6 or 7	Recommended	
Lodged	Off	7	D	3 or 4	5–10	4 or 5	Not required	

4. Stabilizer wheels are used to limit the side-to-side and vertical movement of the header when cutting off of the ground.
5. Setting on FM200 draper control.
6. Set the header angle as shallow as possible (setting A) using the center-link and skid shoes while maintaining the cutting height.
7. The header's cutting height is determined by the skid shoe settings and the header angle.
8. Percentage above ground speed.

Table 3.3 Recommended Settings for Cereals (continued)

Stubble Height	203 mm + (8 in. +)						
Stabilizer Wheels	As needed						
Skid Shoe Position	Not applicable						
Crop Condition	Divider Rods	Draper Speed Setting <sup>5</sup>	Header Angle <sup>6,7</sup>	Reel Cam	Reel Speed % <sup>8</sup>	Reel Position	Upper Cross Auger
Light	Off	8	A	4	10-15	6 or 7	Not required
Normal	On	7	A	2	10	6 or 7	Not required
Heavy	On	7	B - C	2	10	6 or 7	Not required
Lodged	Off	7	B - C	3 or 4	5-10	4 or 5	Not required

Table 3.4 Recommended Settings for Lentils

Stubble Height	On ground							
Stabilizer Wheels <sup>9</sup>	Storage							
Skid Shoe Position	Up or middle							
Crop Condition	Divider Rods	Draper Speed Setting <sup>10</sup>	Header Angle <sup>11, 12</sup>	Reel Cam	Reel Speed % <sup>13</sup>	Reel Position	Upper Cross Auger	
Light	On	8	B – C	2	5–10	6 or 7	Not required	
Normal	On	7	B – C	2	10	6 or 7	Not required	
Heavy	On	7	B – C	2	10	6 or 7	Not required	
Lodged	On	7	D	2	5–10	6 or 7	Not required	

9. Stabilizer wheels are used to limit the side-to-side and vertical movement of the header when cutting off of the ground.  
 10. Setting on FM200 draper control.  
 11. Set the header angle as shallow as possible (setting A) using the center-link and skid shoes while maintaining the cutting height.  
 12. The header's cutting height is determined by the skid shoe settings and the header angle.  
 13. Percentage above ground speed.

Table 3.5 Recommended Settings for Peas

Stubble Height	On ground							
Stabilizer Wheels <sup>14</sup>	Storage							
Skid Shoe Position	Up or middle							
Crop Condition	Divider Rods	Draper Speed Setting <sup>15</sup>	Header Angle <sup>16, 17</sup>	Reel Cam	Reel Speed % <sup>18</sup>	Reel Position	Upper Cross Auger	
Light	On	7	B – C	2	5–10	6 or 7	Recommended	
Normal	On	7	B – C	2	10	6 or 7	Recommended	
Heavy	On	7	B – C	2	10	4 or 5	Recommended	
Lodged	On	7	D	2	5–10	4 or 5	Recommended	

14. Stabilizer wheels are used to limit the side-to-side and vertical movement of the header when cutting off of the ground.
15. Setting on FM200 draper control.
16. Set the header angle as shallow as possible (setting A) using the center-link and skid shoes while maintaining the cutting height.
17. The header's cutting height is determined by the skid shoe settings and the header angle.
18. Percentage above ground speed.

Table 3.6 Recommended Settings for Canola

Stubble Height	102–203 mm (4–8 in.)							
Stabilizer Wheels <sup>19</sup>	As needed							
Skid Shoe Position	Down for light or heavy crop conditions, middle or down for normal or lodged crop conditions							
Crop Condition	Divider Rods	Draper Speed Setting <sup>20</sup>	Header Angle <sup>21, 22</sup>	Reel Cam	Reel Speed % <sup>23</sup>	Reel Position	Upper Cross Auger	
Light	On	7	A	2	5–10	6 or 7	Recommended	
Normal	On	7	B – C	1	10	6 or 7	Recommended	
Heavy	On	8	B – C	1	10	3 or 4	Recommended	
Lodged	On	7	D	2	5–10	3 or 4	Recommended	
Stubble Height	203 mm + (8 in. +)							
Stabilizer Wheels <sup>19</sup>	As needed							
Skid Shoe Position	Not applicable							
Crop Condition	Divider Rods	Draper Speed Setting <sup>20</sup>	Header Angle <sup>21, 22</sup>	Reel Cam	Reel Speed % <sup>23</sup>	Reel Position	Upper Cross Auger	
Light	On	7	A	2	5–10	6 or 7	Recommended	
Normal	On	7	B – C	2	10	6 or 7	Recommended	
Heavy	On	8	B – C	1 or 2	10	3 or 4	Recommended	
Lodged	On	7	D	2 or 3	5–10	3 or 4	Recommended	

19. Stabilizer wheels are used to limit the side-to-side and vertical movement of the header when cutting off of the ground.  
 20. Setting on FM200 draper control.  
 21. Set the header angle as shallow as possible (setting A) using the center-link and skid shoes while maintaining the cutting height.  
 22. The header's cutting height is determined by the skid shoe settings and the header angle.  
 23. Percentage above ground speed.

Table 3.7 Recommended Settings for California Rice

Stubble Height	102 mm (<4 in.)									
Stabilizer Wheels <sup>24</sup>	Storage									
Skid Shoe Position	Up or middle									
Crop Condition	Divider Rods <sup>25</sup>	Draper Speed Setting <sup>26</sup>	Header Angle <sup>27, 28</sup>	Reel Cam	Reel Speed % <sup>29</sup>	Reel Position	Upper Cross Auger			
Light	Rice divider rod	4	D	2	10-15	6 or 7	Not required			
Normal	Rice divider rod	4	B - C	2	10	4 or 5	Not required			
Heavy	Rice divider rod	4	B - C	2	10	4 or 5	Not required			
Lodged	Rice divider rod	4	D	2	5-10	4 or 5	Not required			
Stubble Height	102-203 mm (4-8 in.)									
Stabilizer Wheels <sup>24</sup>	As needed									
Skid Shoe Position	Middle or down									
Crop Condition	Divider Rods <sup>25</sup>	Draper Speed Setting <sup>26</sup>	Header Angle <sup>27, 28</sup>	Reel Cam	Reel Speed % <sup>29</sup>	Reel Position	Upper Cross Auger			
Light	Rice divider rod	4	D	3	10-15	6 or 7	Not required			
Normal	Rice divider rod	4	B - C	3	10	6 or 7	Not required			
Heavy	Rice divider rod	4	B - C	3	10	6 or 7	Not required			
Lodged	Rice divider rod	4	D	4	5-10	6 or 7	Not required			

24. Stabilizer wheels are used to limit the side-to-side and vertical movement of the header when cutting off of the ground.  
 25. The rice divider rod is available. The rice divider rod is not required on both ends of header.  
 26. Setting on FM200 draper control.  
 27. Set the header angle as shallow as possible (setting A) using the center-link and skid shoes while maintaining the cutting height.  
 28. The header's cutting height is determined by the skid shoe settings and the header angle.  
 29. Percentage above ground speed.

Table 3.7 Recommended Settings for California Rice (continued)

Stubble Height	203 mm + (8 in. +)									
Stabilizer Wheels <sup>24</sup>	As required									
Skid Shoe Position	Not applicable									
Crop Condition	Divider Rods <sup>25</sup>	Draper Speed Setting <sup>26</sup>	Header Angle <sup>27, 28</sup>	Reel Cam	Reel Speed % <sup>29</sup>	Reel Position	Upper Cross Auger			
Light	Rice divider rod	4	A	3	10-15	6 or 7	Not required			
Normal	Rice divider rod	4	B - C	3	10	6 or 7	Not required			
Heavy	Rice divider rod	4	B - C	3	10	6 or 7	Not required			
Lodged	Rice divider rod	4	D	4	5-10	6 or 7	Not required			



Table 3.8 Recommended Settings for Delta Rice

Stubble Height	51–152 mm (2–6 in.)									
Stabilizer Wheels <sup>30</sup>	As needed									
Skid Shoe Position	Middle or down									
Crop Condition	Divider Rods	Draper Speed Setting <sup>31</sup>	Header Angle <sup>32, 33</sup>	Reel Cam	Reel Speed % <sup>34</sup>	Reel Position	Upper Cross Auger			
Light	Off	6	D	2 or 3	10–15	6 or 7	Not required			
Normal	Off	6	B – C	2 or 3	10	6 or 7	Not required			
Heavy	Off	6	B – C	2 or 3	10	6 or 7	Not required			
Lodged	Off	6	D	3 or 4	5–10	4 or 5	Not required			
Stubble Height	152 mm + (6 in. +)									
Stabilizer Wheels <sup>30</sup>	As needed									
Skid Shoe Position	Not applicable									
Crop Condition	Divider Rods	Draper Speed Setting <sup>31</sup>	Header Angle <sup>32, 33</sup>	Reel Cam	Reel Speed % <sup>34</sup>	Reel Position	Upper Cross Auger			
Light	Off	6	A	2 or 3	10–15	6 or 7	Not required			
Normal	Off	6	B – C	2 or 3	10	6 or 7	Not required			
Heavy	Off	6	B – C	2 or 3	10	6 or 7	Not required			
Lodged	Off	6	D	3 or 4	5–10	4 or 5	Not required			

30. Stabilizer wheels are used to limit the side-to-side and vertical movement of the header when cutting off of the ground.

31. Setting on FM200 draper control.

32. Set the header angle as shallow as possible (setting A) using the center-link and skid shoes while maintaining the cutting height.

33. The header's cutting height is determined by the skid shoe settings and the header angle.

34. Percentage above ground speed.

Table 3.9 Recommended Settings for Edible Beans

Stubble Height	On ground									
Stabilizer Wheels <sup>35</sup>	Storage									
Skid Shoe Position	Up or middle									
Crop Condition	Divider Rods	Draper Speed Setting <sup>36</sup>	Header Angle <sup>37, 38</sup>	Reel Cam	Reel Speed % <sup>39</sup>	Reel Position	Upper Cross Auger			
Light	On	8	D	2	5-10	6 or 7	Not required			
Normal	On	7	B - C	2	10	6 or 7	Not required			
Heavy	On	7	B - C	2	10	6 or 7	Not required			
Lodged	On	7	D	4	5-10	6 or 7	Not required			

35. Stabilizer wheels are used to limit the side-to-side and vertical movement of the header when cutting off of the ground.  
 36. Setting on FM200 draper control.  
 37. Set the header angle as shallow as possible (setting A) using the center-link and skid shoes while maintaining the cutting height.  
 38. The header's cutting height is determined by the skid shoe settings and the header angle.  
 39. Percentage above ground speed.

Table 3.10 Recommended Settings for Flax

Stubble Height	51–153 mm (2–6 in.)							
Stabilizer Wheels <sup>40</sup>	As needed							
Skid Shoe Position	Down for lodged crop conditions, middle or down for other crop conditions							
Crop Condition	Divider Rods	Draper Speed Setting <sup>41</sup>	Header Angle <sup>42, 43</sup>	Reel Cam	Reel Speed % <sup>44</sup>	Reel Position	Upper Cross Auger	
Light	On	8	B – C	2	5–10	6 or 7	Not required	
Normal	On	7	A	2	10	6 or 7	Not required	
Heavy	On	7	B – C	2	10	6 or 7	Not required	
Lodged	On	7	D	2	5–10	6 or 7	Not required	

40. Stabilizer wheels are used to limit the side-to-side and vertical movement of the header when cutting off of the ground.  
 41. Setting on FM200 draper control.  
 42. Set the header angle as shallow as possible (setting A) using the center-link and skid shoes while maintaining the cutting height.  
 43. The header's cutting height is determined by the skid shoe settings and the header angle.  
 44. Percentage above ground speed.

### 3.7.3 Optimizing Header for Straight-Combining Canola

Ripe canola can be straight-combined, but most varieties are susceptible to pod shatter and subsequent seed loss. This section provides information on the recommended attachments, settings, and adjustments to optimize FD2 Series FlexDraper® Headers for straight-combining canola to reduce seed loss.

#### **Recommended attachments**

To optimize the header for straight-combining canola, make the following modifications:

- Install a full-length upper cross auger
- Install vertical knives

#### **NOTE:**

Each kit includes installation instructions and the necessary hardware. For more information, refer to Chapter 5 *Options and Attachments*, page 787.

#### **Recommended settings**

To optimize the header for straight-combining canola, make the following adjustments:

- Relieve the tension on the auger spring. For instructions, refer to *3.8.5 Checking and Adjusting Feed Auger Springs*, page 187.
- Set the reel speed so that it is equal to the combine's ground speed. Increase the speed as needed. For instructions, refer to *3.9.6 Reel Speed*, page 240.
- Set the side draper speed to position six on the in-cab side draper speed control. For instructions, refer to *3.9.8 Side Draper Speed*, page 243.
- Adjust the reel height so that the fingers just engage the crop. For instructions, refer to *3.9.11 Reel Height*, page 247.
- Adjust the reel fore-aft position. For instructions, refer to *Adjusting Reel Fore-Aft Position*, page 253.
- Move the reel fore-aft cylinders to the alternative aft location. For instructions, refer to *Repositioning Fore-Aft Cylinders*, page 253.
- Set the reel cam to position 1. For instructions, refer to *Adjusting Reel Cam*, page 263.
- Set the auger to floating position. For instructions, refer to *3.8.4 Setting Auger Position*, page 185.

### 3.7.4 Reel Settings

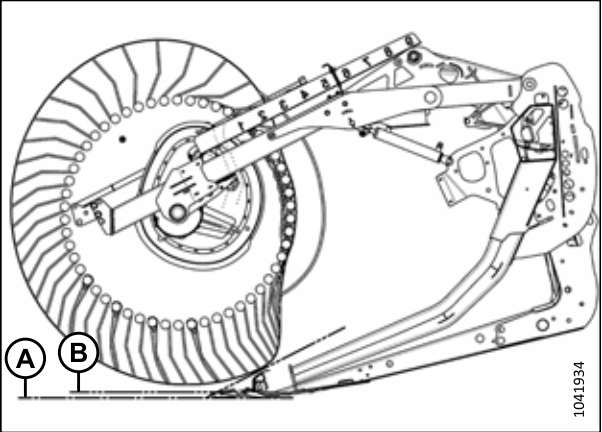
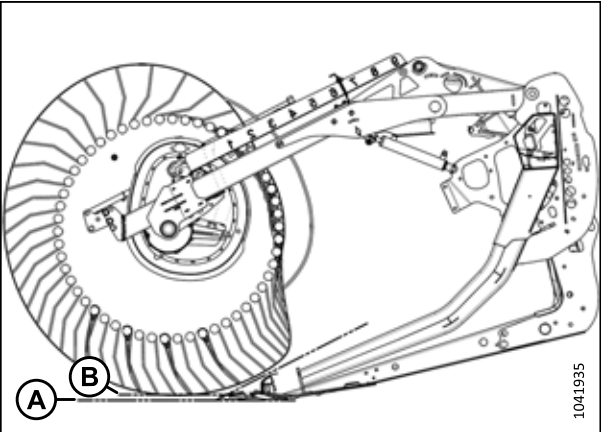
The different combinations of reel positions and cam settings affect the delivery of the crop to the drapers by rotating the finger profile.

#### **NOTE:**

Callout (A) refers to the ground level while callout (B) refers to the stubble height.

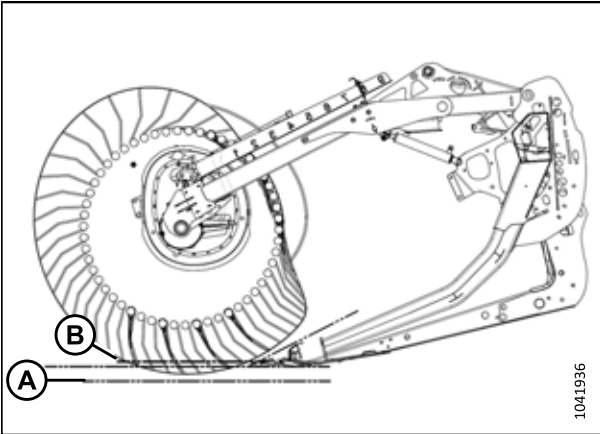
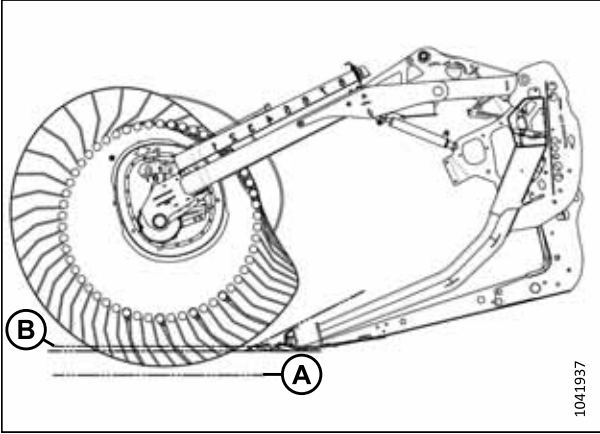
OPERATION

Table 3.11 FD2 Series Recommended Reel Settings

Cam Setting Number (Finger Speed Gain)	Reel Position Number	Reel Finger Pattern	Ground to Stubble Height
1 (0%)	5 or 6		25 mm (0.98 in.)
2 (20%)	6 or 7		25 mm (0.98 in.)

## OPERATION

**Table 3.11 FD2 Series Recommended Reel Settings (continued)**

Cam Setting Number (Finger Speed Gain)	Reel Position Number	Reel Finger Pattern	Ground to Stubble Height
3 (30%)	8		102 mm (4 in.)
4 (35%)	9		150 mm (5.9 in.)

**NOTE:**

- Adjust the reel forward to get closer to the ground while tilting the header back. Fingers/tines will dig into the ground at extreme reel-forward positions, so adjust the skid shoes or header angle to compensate. Adjust the reel rearward to position the reel farther away from the ground when tilting the header forward.
- The header tilt can be increased to position the reel closer to the ground, or decreased to position the reel farther from the ground, while keeping material flowing onto drapers.
- To leave the maximum amount of stubble in lodged crop, raise the header and increase the header tilt to keep the reel close to the ground. Position the reel fully forward.
- The reel may have to be moved back to prevent lumps or plugging on the cutterbar in thinner crops.
- Minimum crop carrying capacity (the minimum area of exposed draper between the reel and the header backsheet) occurs with the reel in the farthest aft position.
- Maximum crop carrying capacity (the maximum area of exposed draper between the reel and the header backsheet) occurs with the reel in the farthest forward position.
- Due to the nature of the cam action, the tip speed of the fingers/tines at the cutterbar becomes higher than that of the reel speed at higher cam settings. For more information, refer to Table 3.11, page 153.

### 3.7.5 Floating Crop Divider Settings (Optional)

Floating crop dividers can be adjusted for different crop conditions.



#### DANGER

To prevent bodily injury or death from the unexpected start-up or fall of a raised machine, always stop the engine, remove the key, and engage the safety props before going under the header for any reason.

For instructions on how to make adjustments to the floating crop divider, refer to *Adjusting Floating Crop Dividers*, page 276. For settings, refer to the applicable stubble height table below.

**Table 3.12 Stubble Height 50 mm to 125 mm (2 in. to 5 in.)**

	Header Angle <sup>45</sup>	Stubble Height	Header Main Shoes	DownStop	Fore Aft Position	Top Deflector Height	Side Deflector Height	Top Deflector Whisker
<b>Normal</b>	A	125 mm (5 in.)	Down	2	1	1	C	In
	A	125 mm (5 in.)	Down	2	3	1	C	In
	E	50 mm (2 in.)	Down	1	1	1.5	C	In
	E	50 mm (2 in.)	Down	1	3	1.5	C	In
<b>Lodged</b>	A	125 mm (5 in.)	Down	2	3	1	C	Out
	A	125 mm (5 in.)	Down	2	4	1	C	Out
	E	50 mm (2 in.)	Down	1	3	2	D	Out
	E	50 mm (2 in.)	Down	1	4	2	D	Out
<b>Severely Lodged</b>	A	125 mm (5 in.)	Down	2	4	3	D	Out
	A	125 mm (5 in.)	Down	2	5	4	D	Out
	E	50 mm (2 in.)	Down	1	4	3	C	Out
	E	50 mm (2 in.)	Down	1	5	4	C	Out

45. A (min) – E (max)

**OPERATION**

**Table 3.13 Stubble Height 20 mm to 100 mm (3/4 in. to 4 in.)**

	<b>Header Angle<sup>45</sup></b>	<b>Stubble Height</b>	<b>Header Main Shoes</b>	<b>DownStop</b>	<b>Fore Aft Position</b>	<b>Top Deflector Height</b>	<b>Side Deflector Height</b>	<b>Top Deflector Whisker</b>
<b>Normal</b>	A	100 mm (4 in.)	Mid	2	1	1	C	In
	A	100 mm (4 in.)	Mid	2	3	1	C	In
	E	20 mm (3/4 in.)	Mid	1	1	1	C	In
	E	20 mm (3/4 in.)	Mid	1	3	1	C	In
<b>Lodged</b>	A	100 mm (4 in.)	Mid	2	3	1	C	Out
	A	100 mm (4 in.)	Mid	2	4	2	C	Out
	E	20 mm (3/4 in.)	Mid	1	3	1	D	Out
	E	20 mm (3/4 in.)	Mid	1	4	2	D	Out
<b>Severely Lodged</b>	A	100 mm (4 in.)	Mid	2-3	4	3	D	Out
	A	100 mm (4 in.)	Mid	2-3	5	4	D	Out
	E	20 mm (3/4 in.)	Mid	1	4	3	C	Out
	E	20 mm (3/4 in.)	Mid	1	5	4	C	Out



**OPERATION**

**Table 3.14 Stubble Height 16 mm to 50 mm (5/8 in. to 2 in.) Cutterbar on Ground**

	<b>Header Angle<sup>45</sup></b>	<b>Stubble Height</b>	<b>Header Main Shoes</b>	<b>DownStop</b>	<b>Fore Aft Position</b>	<b>Top Deflector Height</b>	<b>Side Deflector Height</b>	<b>Top Deflector Whisker</b>
<b>Normal</b>	A	50 mm (2 in.)	Up	2	1-3	1	C	In
	A	50 mm (2 in.)	Up	2	1-3	1	C	In
	E	16 mm (5/8 in.)	Up	1	1	2	C	In
	E	16 mm (5/8 in.)	Up	1	3	1	C	In
<b>Lodged</b>	A	50 mm 2 inch	Up	2	3	1	C	Out
	A	50 mm (2 in.)	Up	3	4	1	C	Out
	E	16 mm (5/8 in.)	Up	1	3-4	2	D	Out
	E	16 mm (5/8 in.)	Up	1	3-4	2	D	Out
<b>Severely Lodged</b>	A	50 mm (2 in.)	Up	2-3	4	3	D	Out
	A	50 mm (2 in.)	Up	2-3	5	4	D	Out
	E	16 mm (5/8 in.)	Up	1	4	2.5	C	Out
	E	16 mm (5/8 in.)	Up	1	5	4	C	Out

### 3.8 Float Module Setup

The following sections outline the recommended float module setup guidelines for your specific combine model and crop type; however, the recommendations cannot cover all conditions.

If feeding problems develop with the float module, refer to Chapter [6 Troubleshooting, page 809](#).

#### 3.8.1 FM200 Feed Auger Performance Configurations

The FM200 feed auger can be configured to suit various crop conditions; there are five configurations available.

**Ultra Narrow Configuration:** Ultra Narrow Configuration uses 8 long bolt-on flightings (4 on the left and 4 on the right) and 18 auger fingers. This configuration may improve feeding performance on combines with narrow feeder houses. It may also be helpful when harvesting rice.

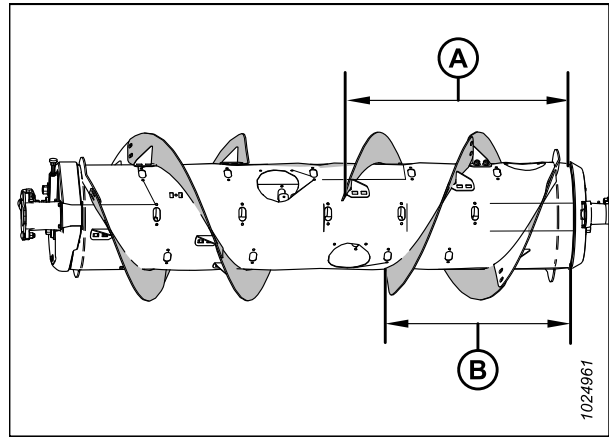
**NOTE:**

Dimensions (A) and (B) are the same for both ends of the auger. They should be within 15 mm (9/16 in.) of the numbers given.

**NOTE:**

You will need to drill holes in the flighting and in the drum to install the extra flighting.

For more information on converting the auger to an Ultra Narrow Configuration, refer to [Ultra Narrow Configuration – Auger Flighting, page 160](#).



**Figure 3.200: Ultra Narrow Configuration – Rear View**  
 A - 760 mm (29 15/16 in.)      B - 602 mm (23 11/16 in.)

**Narrow Configuration:** Narrow Configuration uses 4 long bolt-on flightings (2 on the left and 2 on the right) and 18 feed auger fingers.

**NOTE:**

Dimensions (A) and (B) are the same for both ends of the auger. They should be within 15 mm (9/16 in.) of the numbers given.

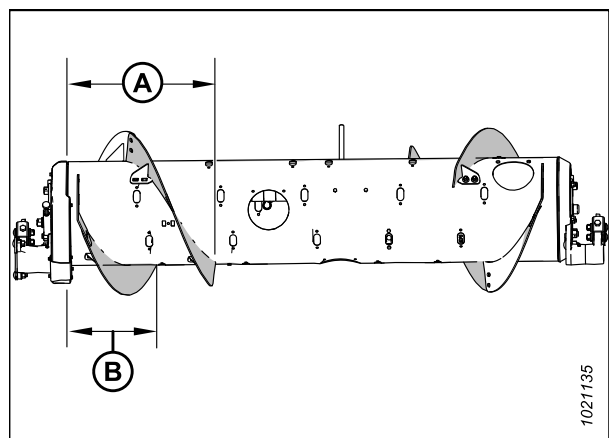
**Narrow Configuration** is standard for the following combines:

- IDEAL™ 7/8/9/10
- Gleaner® R6/75, R6/76, S6/77, S6/7/88, S96/7/8
- New Holland CR 920/940/960, 9020/40/60/65, 6090/7090, 8060/8070/8080

**Narrow Configuration** is recommended for the following combines:

- Case 2166/88, 2344/66/77/88, 2577/88, 5/6/7088, 5/6/7130, 5/6/7140, 5/6/7150

For more information on converting the auger to a Narrow Configuration, refer to [Narrow Configuration – Auger Flighting, page 164](#).



**Figure 3.201: Narrow Configuration – Rear View**  
 A - 514 mm (20 1/4 in.)      B - 356 mm (14 in.)

## OPERATION

**Medium Configuration:** Medium Configuration uses 4 short bolt-on flightings (2 on the left and 2 on the right) and 22 feed auger fingers.

### NOTE:

Dimensions (A) and (B) are the same for both ends of the auger. They should be within 15 mm (9/16 in.) of the numbers given.

**Medium Configuration** is standard for the following combines:

- Case IH 2166/88, 2344/66/77/88, 2577/88, 5/6/7088, 5/6/7130, 5/6/7140, 5/6/7150, 7/8/9230, 7/8/9240, 7/8/9250
- Challenger® 66/67/680B, 54/560C, 54/560E
- CLAAS 56/57/58/590R, 57/58/595R, 62/63/64/65/66/670, 73/74/75/76/77/780, 5X00, 6X00, 7X00, 8X00
- Fendt 9490x, 6335C
- Gleaner® A66/76/86
- John Deere 95/96/97/9860, 95/96/97/9870, S65/66/67/68/690, T670
- Massey Ferguson® 92/9380, 96/97/9895, 9520/40/60, 9500, 9545/65
- New Holland CR 970/980, 9070/9080, 8090/9090, X.90, X.80
- New Holland CX 8X0, 80X0, 8.X0
- Rostselmash 161, T500, Torum X70, Torum 785

For more information on converting the auger to a Medium Configuration, refer to [Medium Configuration – Auger Flighting, page 167](#).

**Wide Configuration:** Wide Configuration uses 2 short bolt-on flightings (1 on the left and 1 on the right) and 30 feed auger fingers.

### NOTE:

Dimensions (A) and (B) are the same for both ends of the auger. They should be within 15 mm (9/16 in.) of the numbers given.

**Wide Configuration** is standard for the following combines:

- John Deere X9 1000, 1100

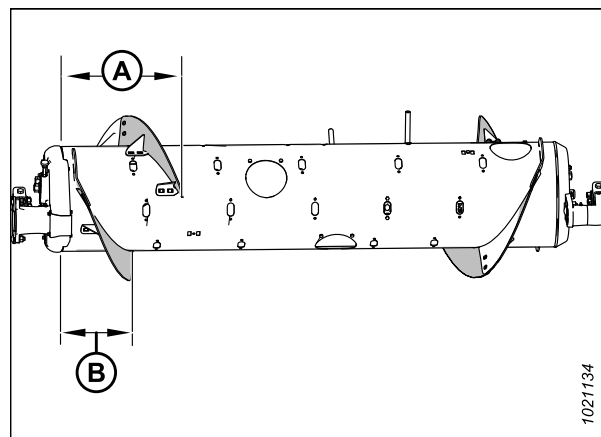
**Wide Configuration** is optional for the following combines:

- Challenger® 670B/680B, 540C/560C, 540E/560E
- CLAAS 590R/595R, 660/670, 760/770/780, 5X00, 6X00, 7X00, 8X00
- Massey Ferguson® 9895, 9540, 9560, 9545, 9565, 9380
- New Holland CX 8X0, 80X0, 8.X0

### NOTE:

This configuration may increase combine capacity on wide feeder house combines in certain crop conditions.

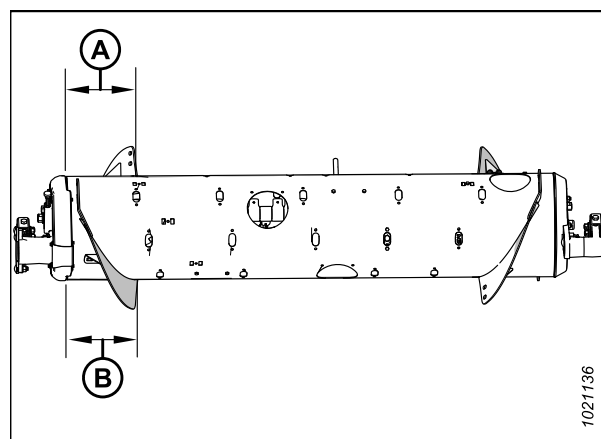
For more information on converting the auger to a Wide Configuration, refer to [Wide Configuration – Auger Flighting, page 169](#).



**Figure 3.202: Medium Configuration – Rear View**

A - 410 mm (16 1/8 in.)

B - 260 mm (10 1/4 in.)



**Figure 3.203: Wide Configuration – Rear View**

A - 257 mm (10 1/8 in.)

B - 257 mm (10 1/8 in.)

## OPERATION

**Ultra Wide Configuration:** Ultra Wide Configuration uses only factory-welded flighting (A) is responsible for conveying the crop. No bolt-on flighting is installed and a total of 30 auger fingers are recommended for this configuration.

**Ultra Wide Configuration** is optional for wide feeder house combines.

**NOTE:**

This configuration may improve feeding for wide feeder house combines.

For more information on converting the auger to an Ultra Wide Configuration, refer to [Ultra Wide Configuration – Auger Flighting](#), page 172.

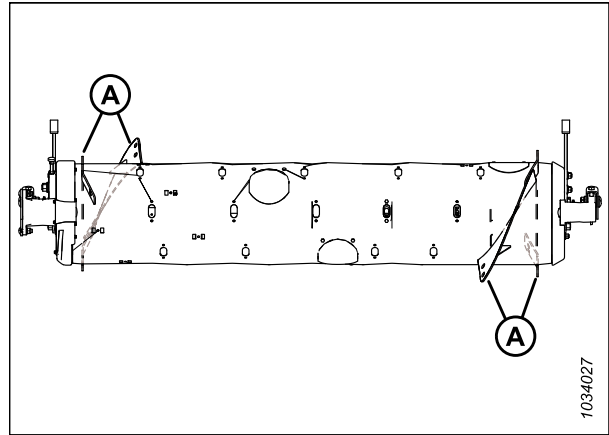


Figure 3.204: Ultra Wide Configuration – Rear View

### *Ultra Narrow Configuration – Auger Flighting*

Ultra Narrow Configuration uses eight long bolt-on flightings (four on the left and four on the right), and 18 auger fingers are recommended.

**NOTE:**

You will need to drill holes in the flighting and in the drum to install the four additional flightings.

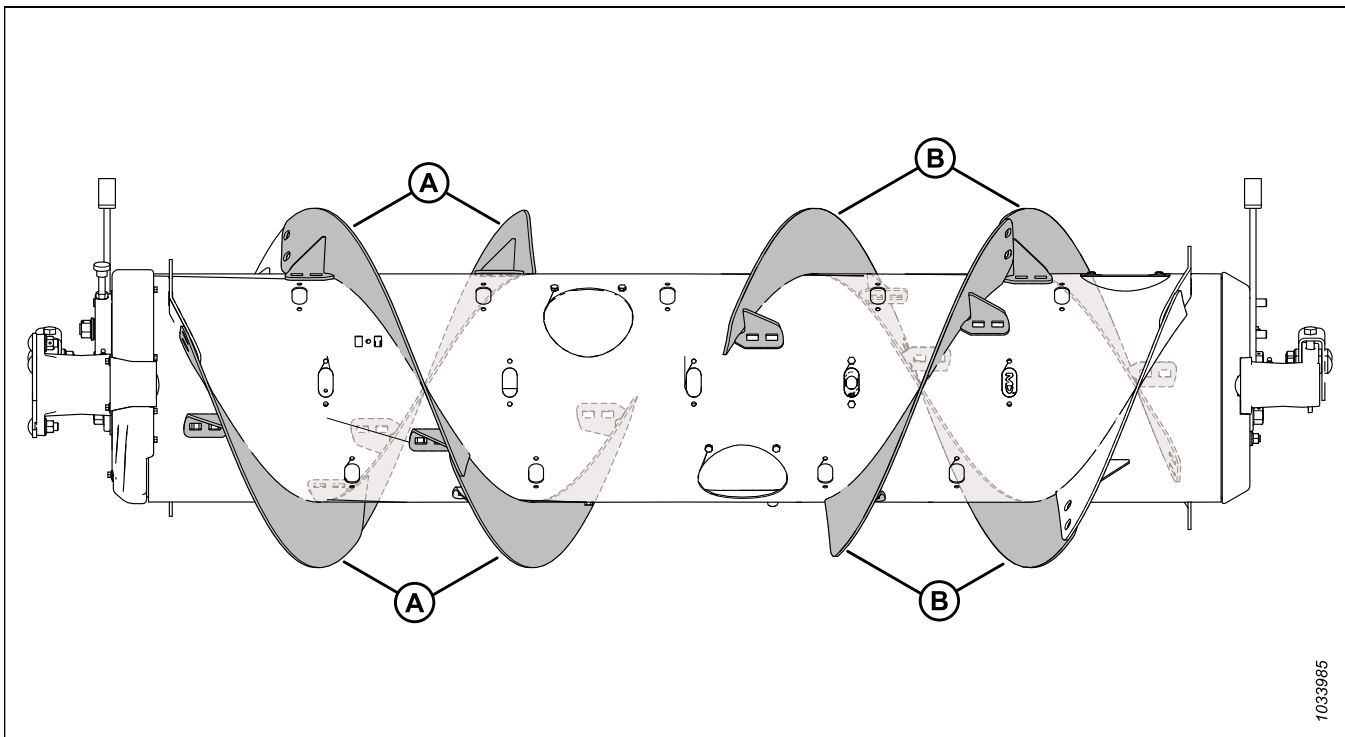


Figure 3.205: Ultra Narrow Configuration

A - Left Long Flighting (MD #287889)

B - Right Long Flighting (MD #287890)

**To convert to Ultra Narrow Configuration from Narrow Configuration:**

One flighting kit (MD #357234 or B7345<sup>46</sup>) and some hole-drilling are required to install flightings (A). Add or remove auger fingers as necessary to optimize feeding for your combine and crop conditions.

**IMPORTANT:**

Extra hardware is included in these kits. Install the hardware correctly to prevent damage and to maximize performance.

- For flighting installation instructions, refer to *Installing Bolt-On Flighting, page 176*.
- To install the additional flightings that require hole drilling, refer to *Installing Additional Bolt-On Flighting – Ultra Narrow Configuration Only, page 179*.
- For finger installation/removal instructions, refer to *3.8.3 Installing Feed Auger Fingers, page 184* and *3.8.2 Removing Feed Auger Fingers, page 181*.

**To convert to Ultra Narrow Configuration from Medium, Wide, or Ultra Wide Configuration:**

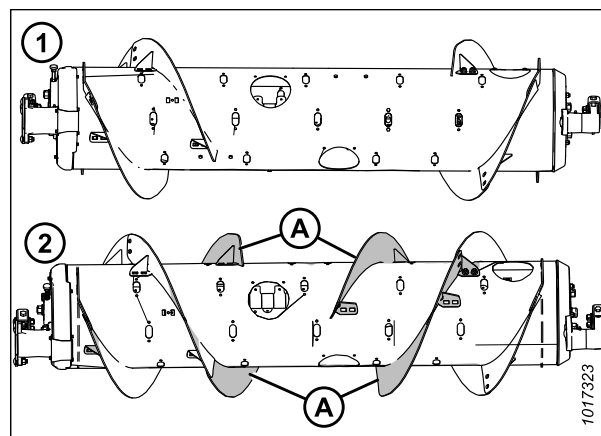
Two flighting kits (MD #357234 or B7345<sup>46</sup>) and some hole-drilling is required to convert to this configuration.

You will need to replace existing short flightings (A)<sup>47</sup> with long flightings (B). Add or remove auger fingers as necessary to optimize feeding for your combine and crop conditions.

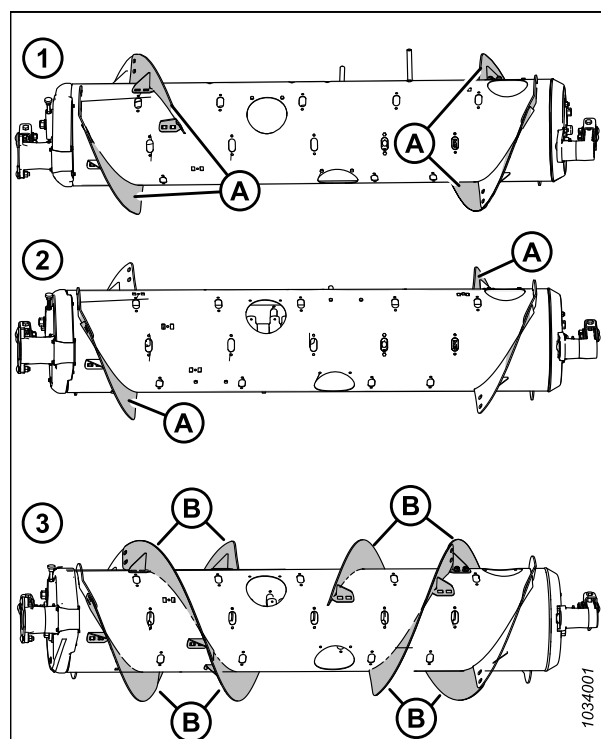
**IMPORTANT:**

Extra hardware is included in these kits. Install the hardware correctly to prevent damage and to maximize performance.

- For flighting replacement instructions, refer to *Removing Bolt-On Flighting, page 174* and *Installing Bolt-On Flighting, page 176*.
- To install the additional flightings that require hole drilling, refer to *Installing Additional Bolt-On Flighting – Ultra Narrow Configuration Only, page 179*.
- For finger installation/removal instructions, refer to *3.8.3 Installing Feed Auger Fingers, page 184* and *3.8.2 Removing Feed Auger Fingers, page 181*.



**Figure 3.206: Auger Configurations – Rear View**  
1 - Narrow Configuration      2 - Ultra Narrow Configuration



**Figure 3.207: Auger Configurations – Rear View**  
1 - Medium Configuration      2 - Wide Configuration  
3 - Ultra Narrow Configuration

46. MD #357234 is available only through MacDon Parts. B7345 is available only through MacDon Whole Goods. Both kits contain wear-resistant flightings.

47. The quantity of existing short flightings is either 0, 2, or 4, depending on the current configuration.

## OPERATION

### NOTE:

If you are converting the auger from Ultra Wide Configuration, there is no existing bolt-on flighting to remove because that configuration uses only the factory-welded flighting (A).

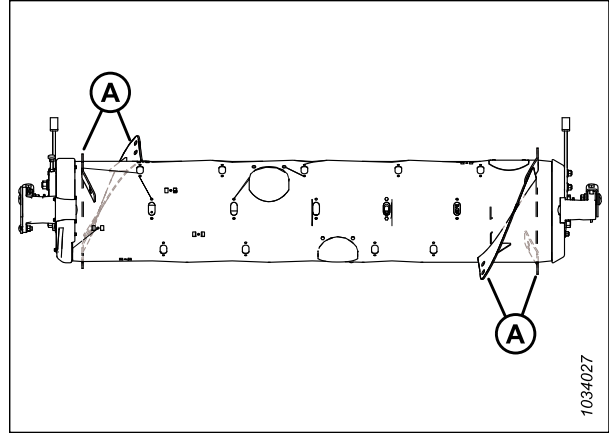


Figure 3.208: Ultra Wide Configuration

OPERATION

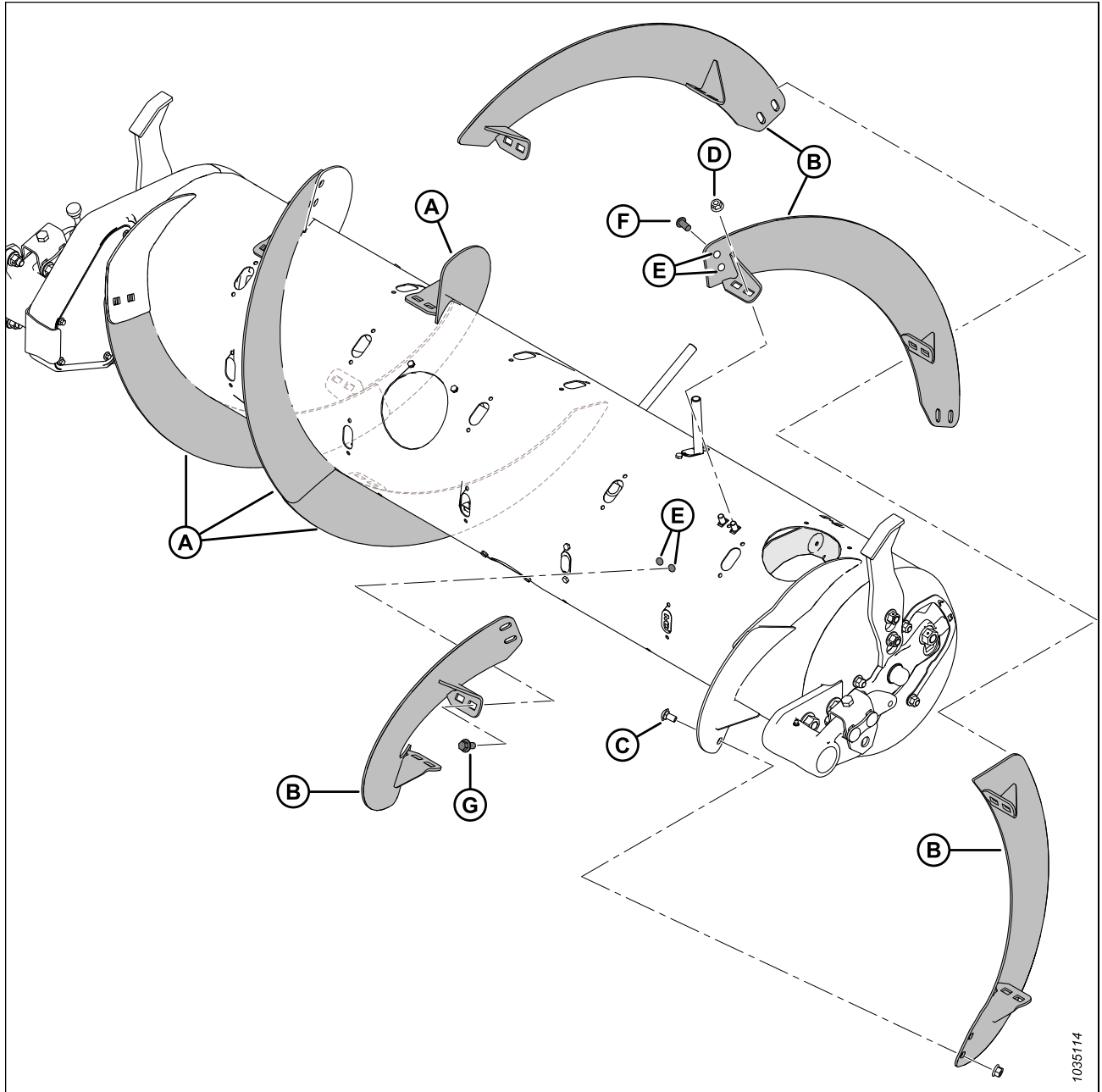


Figure 3.209: Ultra Narrow Configuration

A - Left Long Flighting (MD #287889)

B - Right Long Flighting (MD #287890)

C - M10 x 20 mm Carriage Bolt (MD #136178)

D - M10 Center Lock Flange Nut (MD #135799)

E - Drilled Holes – 11 mm (7/16 in.)<sup>48</sup>

F - M10 x 20 mm Button Head Bolt (MD #135723)<sup>49</sup>

G - M10 x 20 mm Flange Head Bolt (MD #152655)<sup>50</sup>

48. Each of the four additional flightings require six drilled holes to install (four in the auger and two in the adjacent flighting).

49. Used on the holes drilled in the existing flighting.

50. Used on the holes drilled in the auger.

## OPERATION

### Narrow Configuration – Auger Flighting

Narrow Configuration uses four long bolt-on flightings (two on the left and two on the right), and 18 auger fingers.

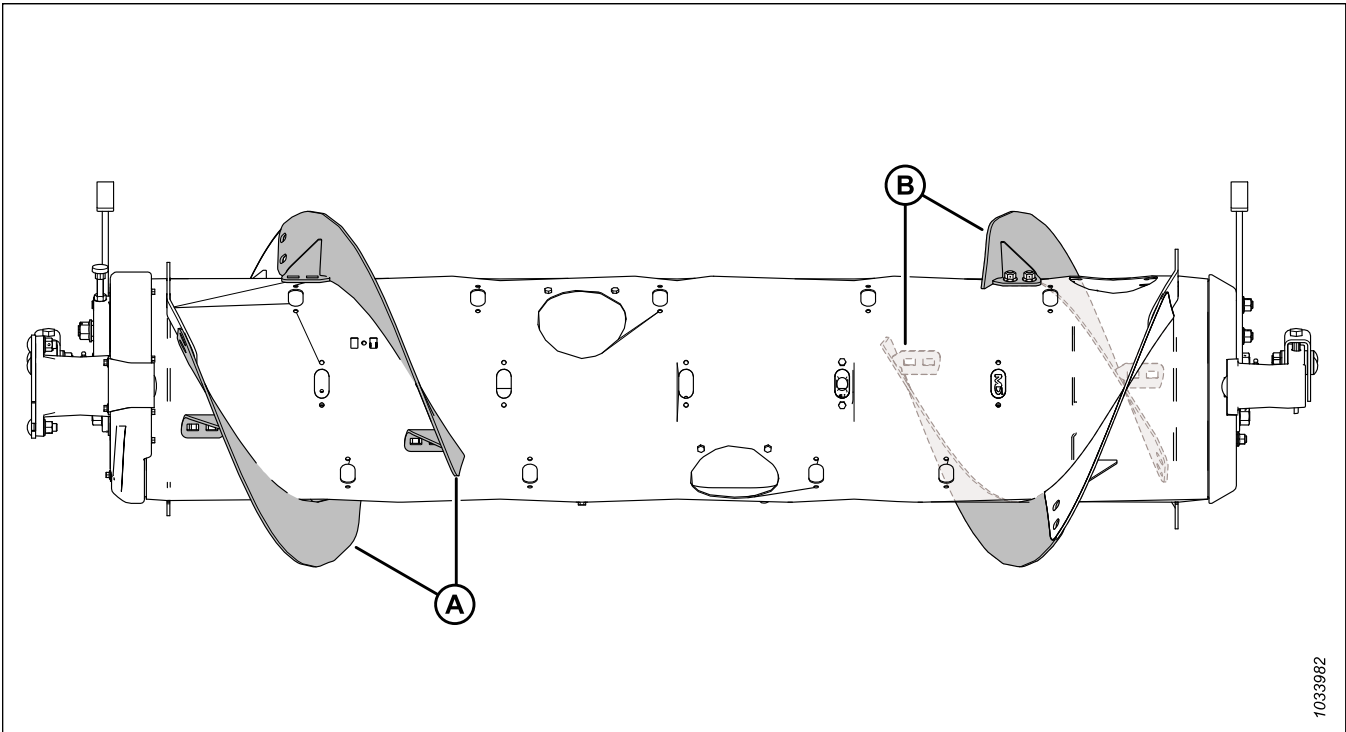


Figure 3.210: Narrow Configuration

A - Left Long Flighting (MD #287889)

B - Right Long Flighting (MD #287890)

### To convert the auger to Narrow Configuration from Ultra Narrow Configuration:

Remove four flightings (A) from the auger and install additional auger fingers. A total of 18 auger fingers is recommended for this configuration.

- For flighting removal instructions, refer to [Removing Bolt-On Flighting, page 174](#).
- For finger installation instructions, refer to [3.8.3 Installing Feed Auger Fingers, page 184](#).

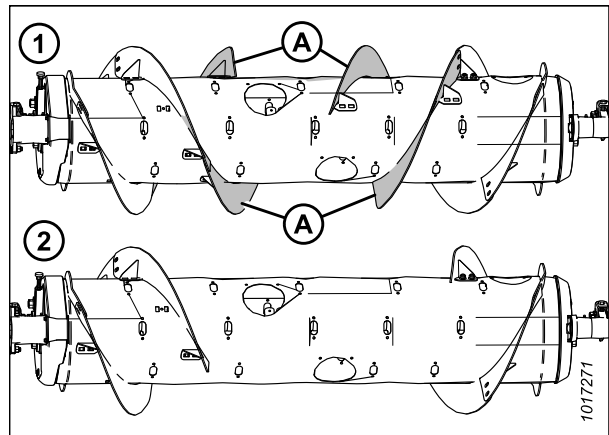


Figure 3.211: Auger Configurations – Rear View

1 - Ultra Narrow Configuration

2 - Narrow Configuration



## OPERATION

### To convert the auger to Narrow Configuration from Medium, Wide, or Ultra Wide Configuration:

One flighting kit (MD #357234 or B7345<sup>51</sup>) is required. You will need to replace any of the existing short flightings (A)<sup>52</sup> with long flightings (B) and remove the extra auger fingers. A total of 18 auger fingers is recommended for this configuration.

#### IMPORTANT:

Extra hardware is included in these kits. Install the hardware correctly to prevent damage and to maximize performance.

- For flighting replacement instructions, refer to [Removing Bolt-On Flighting, page 174](#) and [Installing Bolt-On Flighting, page 176](#).
- For finger removal instructions, refer to [3.8.2 Removing Feed Auger Fingers, page 181](#).

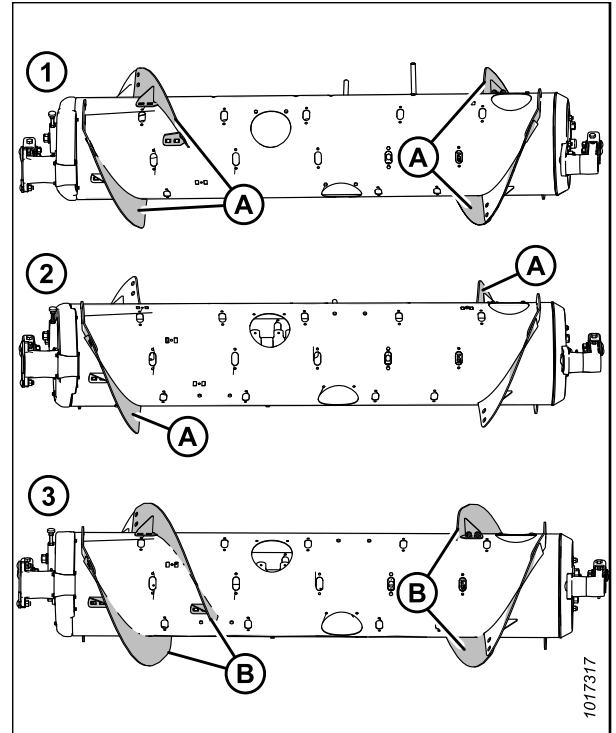


Figure 3.212: Auger Configurations – Rear View

1 - Medium Configuration  
3 - Narrow Configuration

2 - Wide Configuration

#### NOTE:

If you are converting the auger from Ultra Wide Configuration, there is no existing bolt-on flighting to remove because that configuration uses only the factory-welded flighting (A).

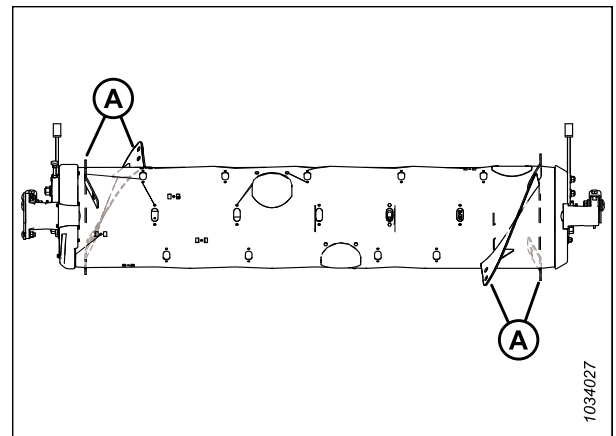


Figure 3.213: Ultra Wide Configuration

51. MD #357234 is available only through MacDon Parts. B7345 is available only through MacDon Whole Goods. Both kits contain wear-resistant flightings.

52. The quantity of existing short flightings is either 0, 2, or 4, depending on the current configuration.

OPERATION

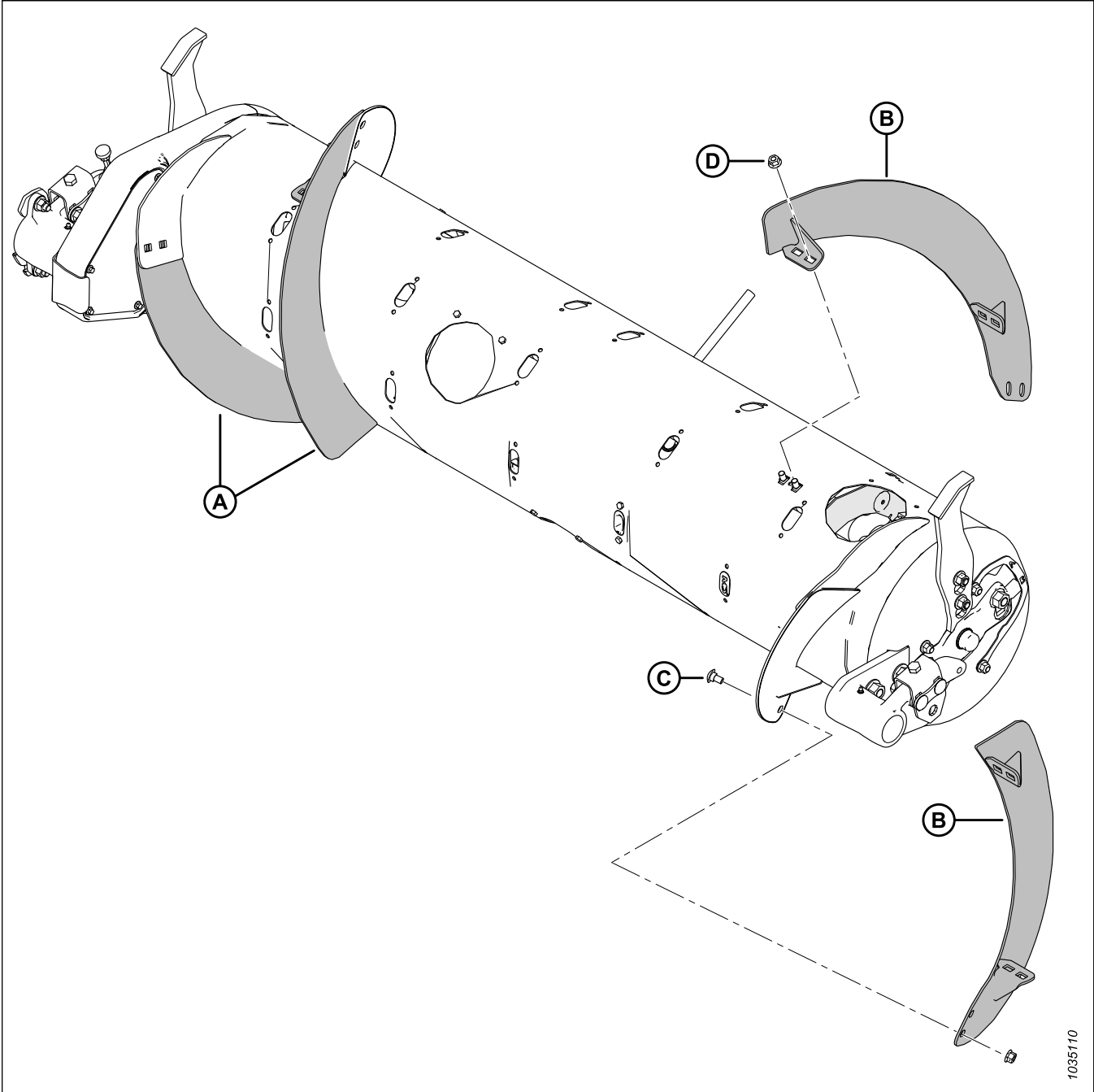


Figure 3.214: Narrow Configuration

A - Left Long Flighting (MD #287889)

B - Right Long Flighting (MD #287890)

C - M10 x 20 mm Carriage Bolt (MD #136178)

D - M10 Center Lock Flange Nut (MD #135799)

## OPERATION

### Medium Configuration – Auger Flighting

Medium Configuration uses four short bolt-on flightings (two on the left and two on the right), and 22 auger fingers are recommended.

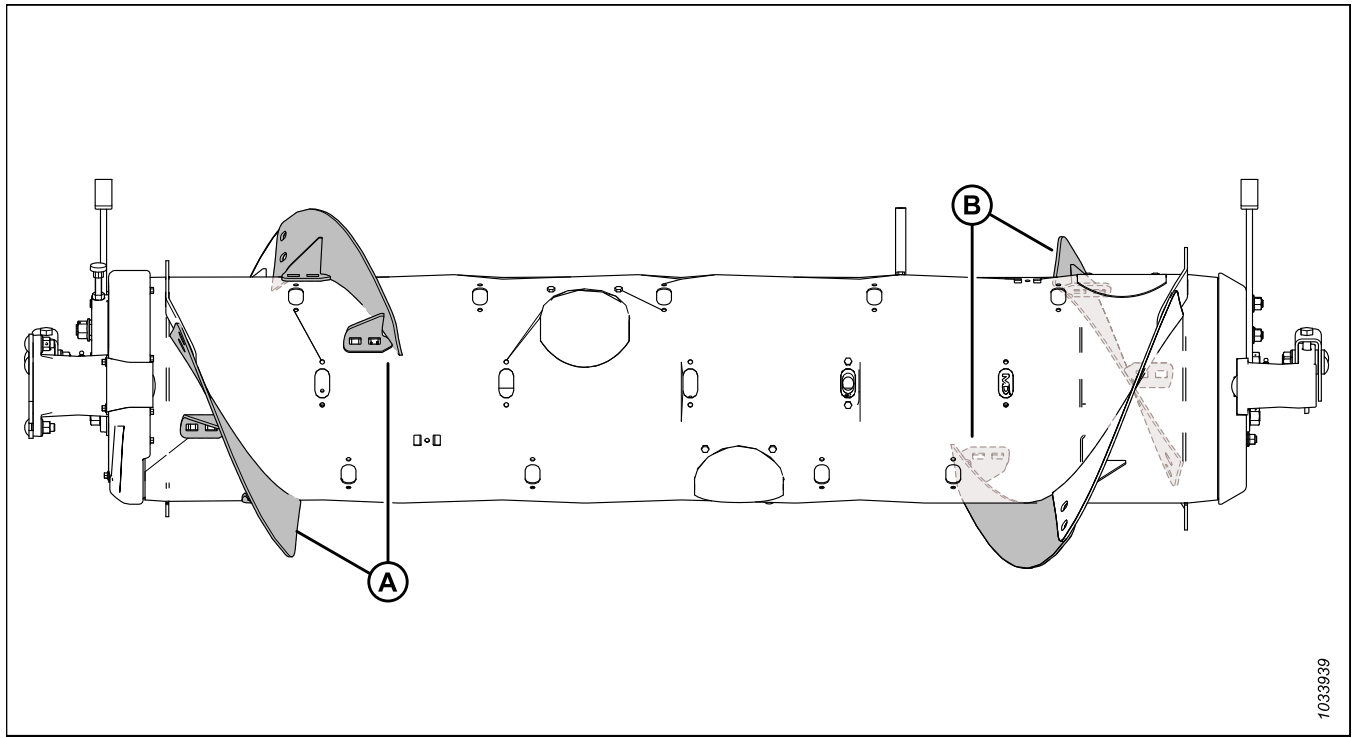


Figure 3.215: Medium Configuration

A - Left Short Flighting (MD #287888)

B - Right Short Flighting (MD #287887)

#### To convert to Medium Configuration from Wide Configuration:

One flighting kit (MD #357233 or B7344<sup>53</sup>) is required. You will need to install new flightings (A) and remove the extra auger fingers. A total of 22 auger fingers is recommended for this configuration.

- For flighting installation instructions, refer to [Installing Bolt-On Flighting, page 176](#).
- For finger removal instructions, refer to [3.8.2 Removing Feed Auger Fingers, page 181](#).

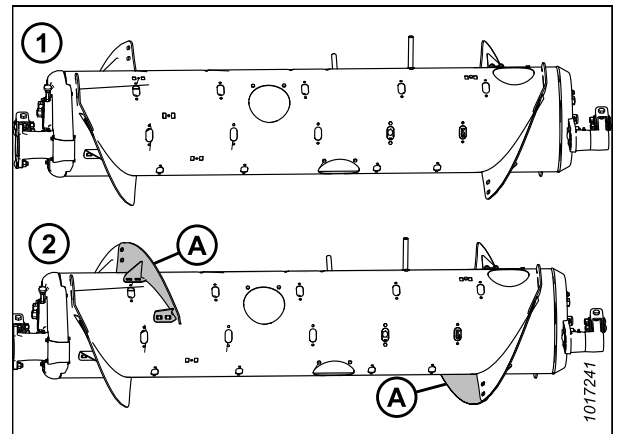


Figure 3.216: Auger Configurations – Rear View

1 - Wide Configuration

2 - Medium Configuration

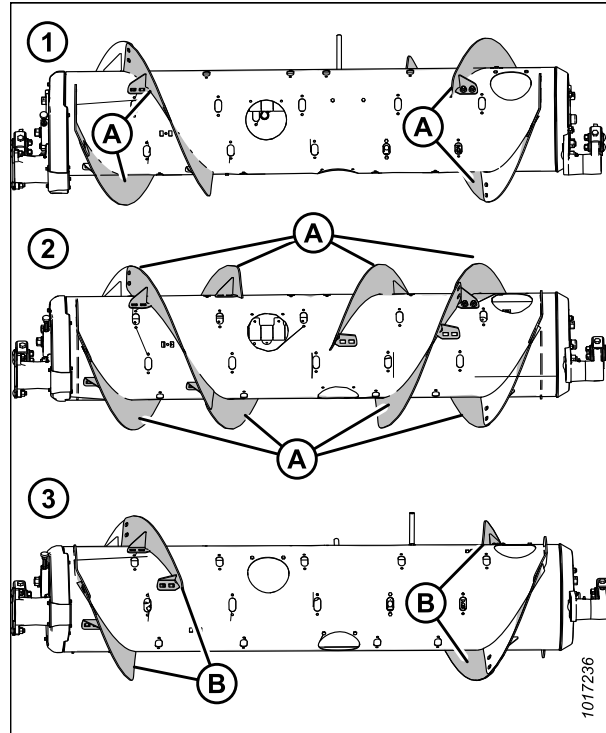
53. MD #357233 is available only through MacDon Parts. B7344 is available only through MacDon Whole Goods. Both kits contain wear-resistant flightings.

## OPERATION

### To convert to Medium Configuration from Narrow or Ultra Narrow Configuration:

Two flighting kits (MD #357233 or B7344<sup>53</sup>) are required. You will need to replace long flightings (A)<sup>54</sup> with short flightings (B) and install additional auger fingers. A total of 22 auger fingers is recommended for this configuration.

- For flighting replacement instructions, refer to [Removing Bolt-On Flighting, page 174](#) and [Installing Bolt-On Flighting, page 176](#).
- For finger installation instructions, refer to [3.8.3 Installing Feed Auger Fingers, page 184](#).



**Figure 3.217: Auger Configurations – Rear View**

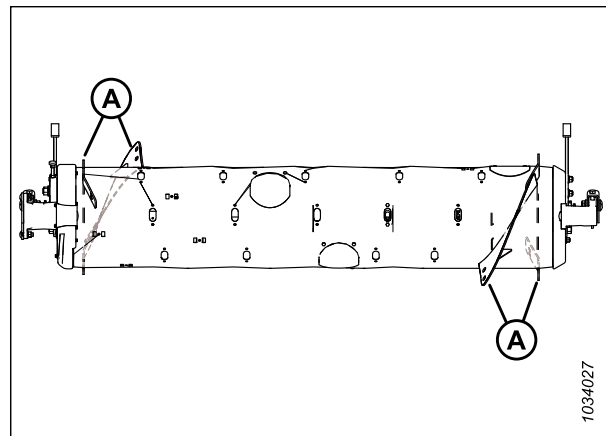
1 - Narrow Configuration  
3 - Medium Configuration

2 - Ultra Narrow Configuration

### To convert to Medium Configuration from Ultra Wide Configuration:

Two flighting kits (MD #357233 or B7344<sup>53</sup>) are required. You will need to install four short flightings onto the existing welded flightings (A) and remove the extra auger fingers. A total of 22 auger fingers is recommended for this configuration.

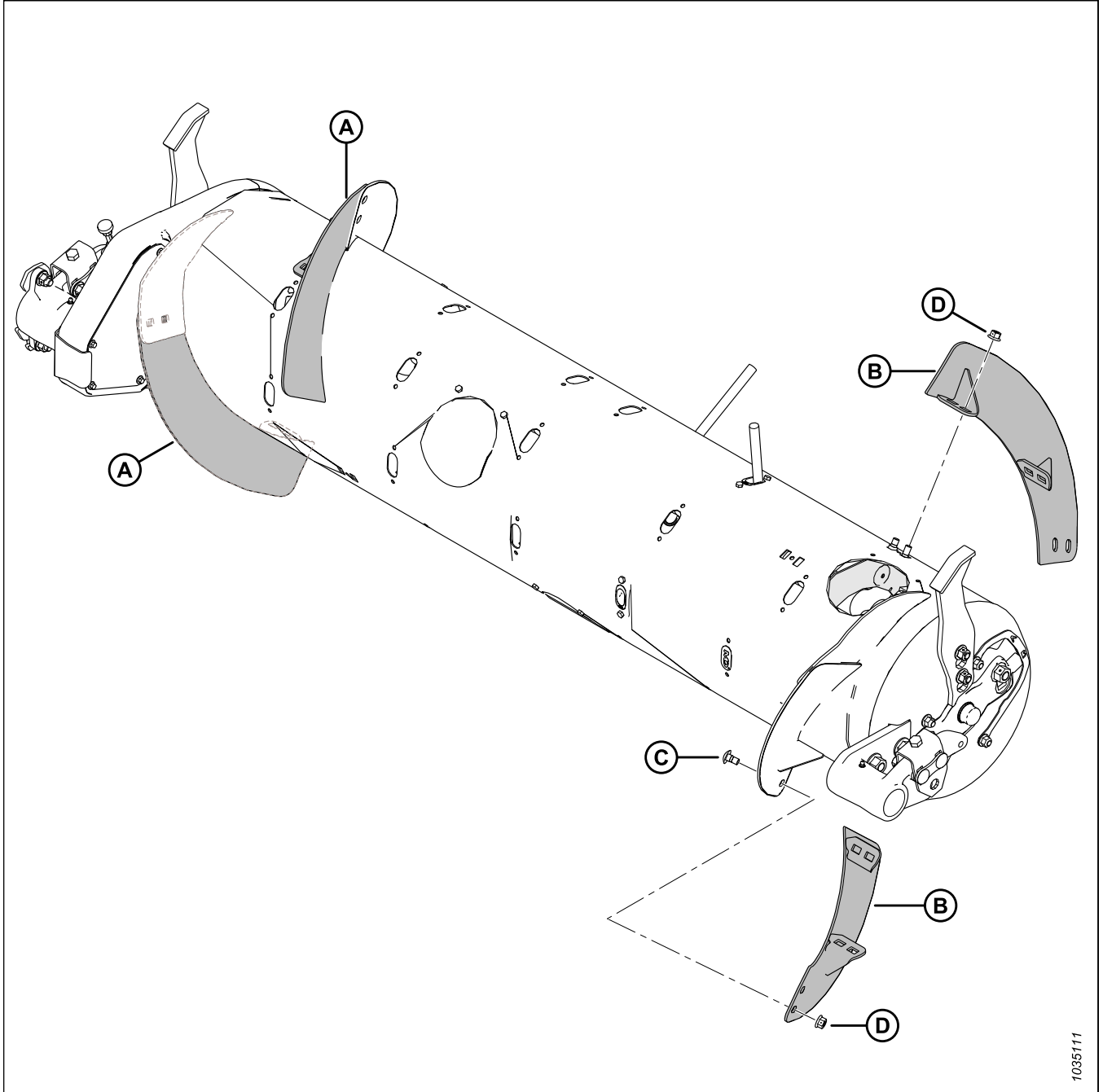
- For flighting installation instructions, refer to [Installing Bolt-On Flighting, page 176](#).
- For finger removal instructions, refer to [3.8.2 Removing Feed Auger Fingers, page 181](#).



**Figure 3.218: Ultra Wide Configuration**

54. The quantity of existing long flightings is either 4 or 8, depending on the current configuration.

## OPERATION



**Figure 3.219: Medium Configuration**

A - Left Short Flighting (MD #287888)

B - Right Short Flighting (MD #287887)

C - M10 x 20 mm Carriage Bolt (MD #136178)

D - M10 Center Lock Flange Nut (MD #135799)

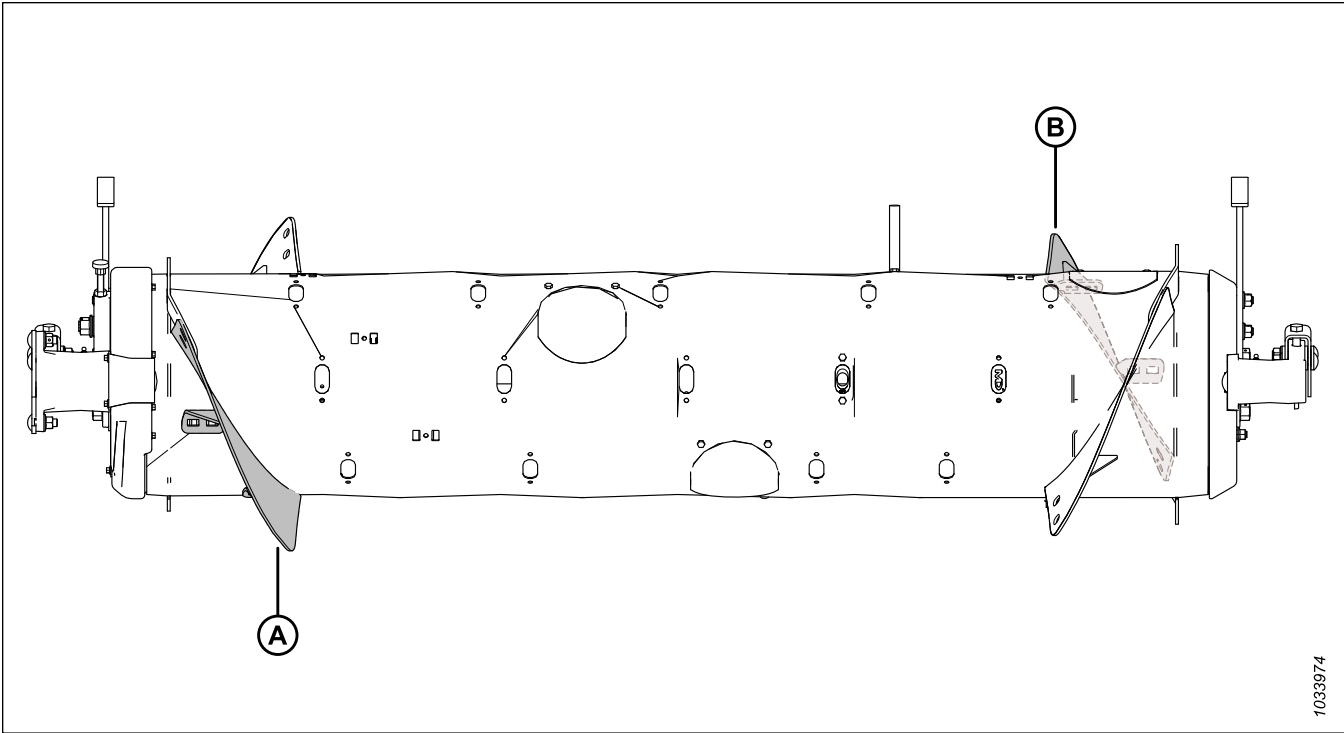
### *Wide Configuration – Auger Flighting*

Wide Configuration uses two short bolt-on flightings (one on the left and one on the right), and 30 auger fingers are recommended.

#### **NOTE:**

This configuration may increase combine capacity on wide feeder house combines in certain crop conditions.

## OPERATION



**Figure 3.220: Wide Configuration**

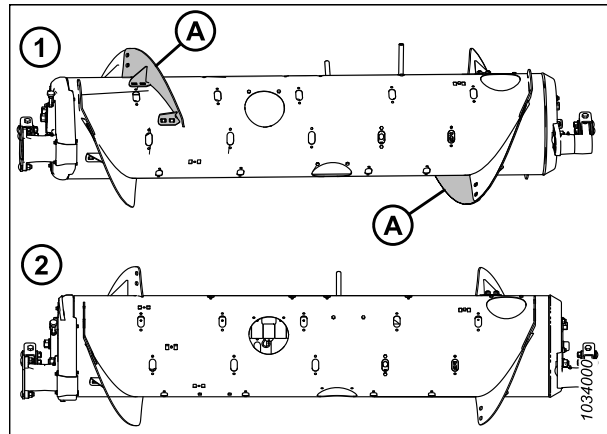
A - Left Short Flighting (MD #287888)

B - Right Short Flighting (MD #287887)

### To convert to Wide Configuration from Medium Configuration:

Remove existing flightings (A) from the auger and install additional auger fingers. A total of 30 auger fingers is recommended for this configuration.

- For flighting removal instructions, refer to [Removing Bolt-On Flighting, page 174](#).
- For finger installation instructions, refer to [3.8.3 Installing Feed Auger Fingers, page 184](#).



**Figure 3.221: Auger Configurations – Rear View**

1 - Medium Configuration

2 - Wide Configuration

## OPERATION

### To convert to Wide Configuration from Ultra Wide Configuration:

One flighting kit (either MD #357233 or B7344<sup>55</sup>) is required. You will need to install two short flightings onto the existing welded flightings (A). A total of 30 auger fingers is recommended for this configuration.

- For flighting installation instructions, refer to *Installing Bolt-On Flighting, page 176*.
- If required to remove auger fingers, refer to *3.8.2 Removing Feed Auger Fingers, page 181*.

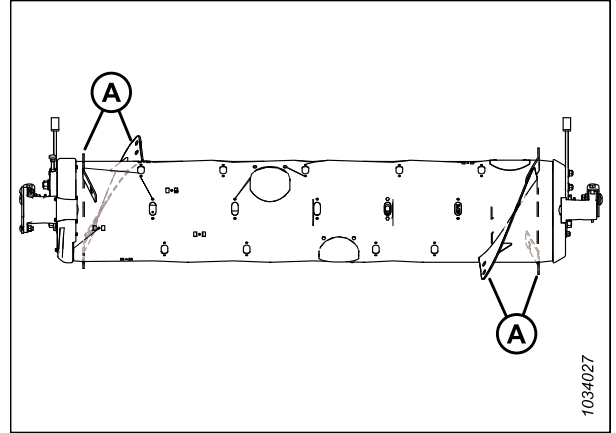


Figure 3.222: Ultra Wide Configuration

### To convert to Wide Configuration from Narrow or Ultra Narrow Configuration:

One flighting kit (MD #357233 or B7344<sup>55</sup>) is required. You will need to replace existing long flightings (A)<sup>56</sup> with short flightings (B) and install additional auger fingers. A total of 30 auger fingers is recommended for this configuration.

- For flighting replacement instructions, refer to *Removing Bolt-On Flighting, page 174* and *Installing Bolt-On Flighting, page 176*.
- For finger installation instructions, refer to *3.8.3 Installing Feed Auger Fingers, page 184*.

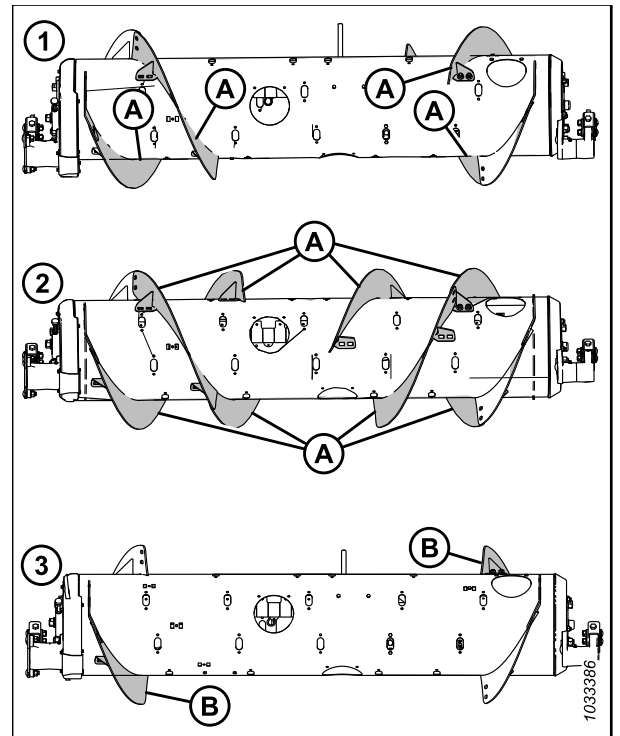


Figure 3.223: Auger Configurations – Rear View

1 - Narrow Configuration

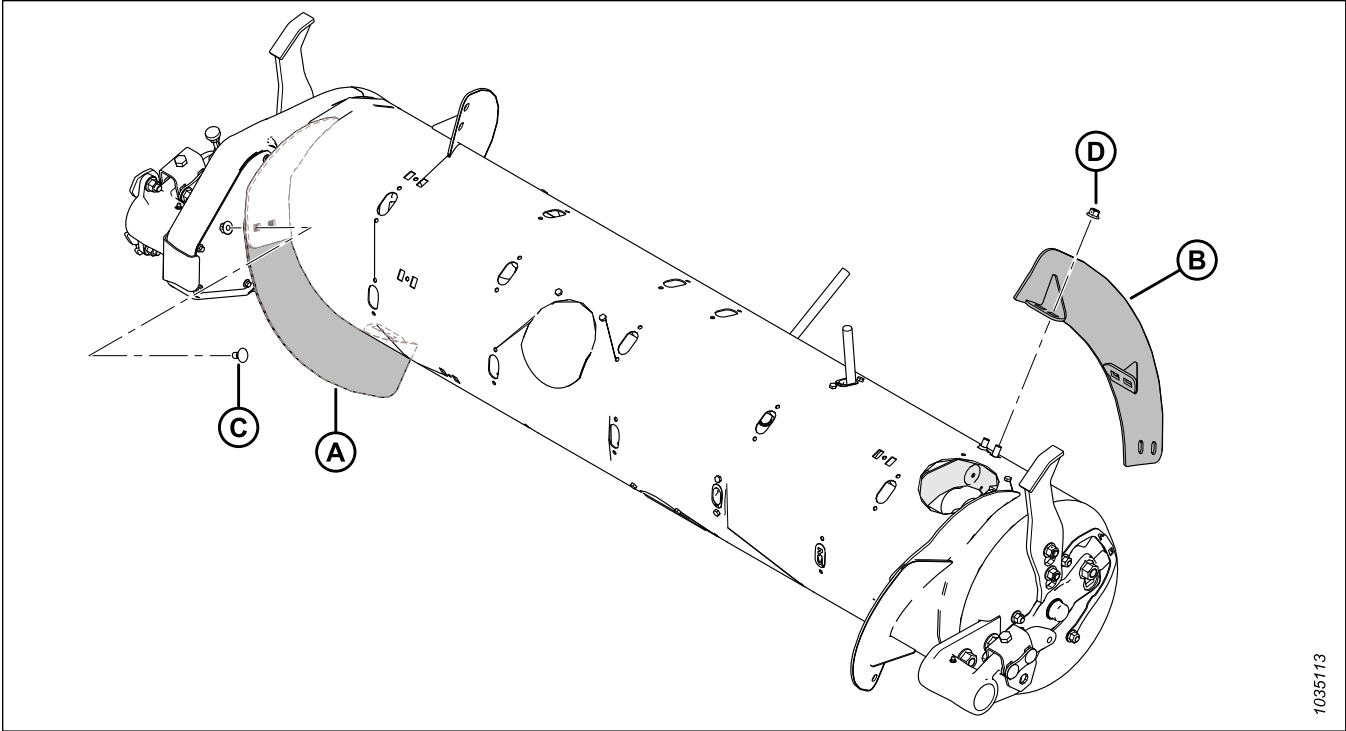
2 - Ultra Narrow Configuration

3 - Wide Configuration

55. MD #357233 is available only through MacDon Parts. B7344 is available only through Whole Goods. Both kits contain wear-resistant flightings.

56. The quantity of existing long flightings is either 4 or 8, depending on the current configuration.

## OPERATION



**Figure 3.224: Wide Configuration**

A - Left Short Fighting (MD #287888)

B - Right Short Fighting (MD #287887)

C - M10 x 20 mm Carriage Bolt (MD #136178)

D - M10 Center Lock Flange Nut (MD #135799)

### *Ultra Wide Configuration – Auger Fighting*

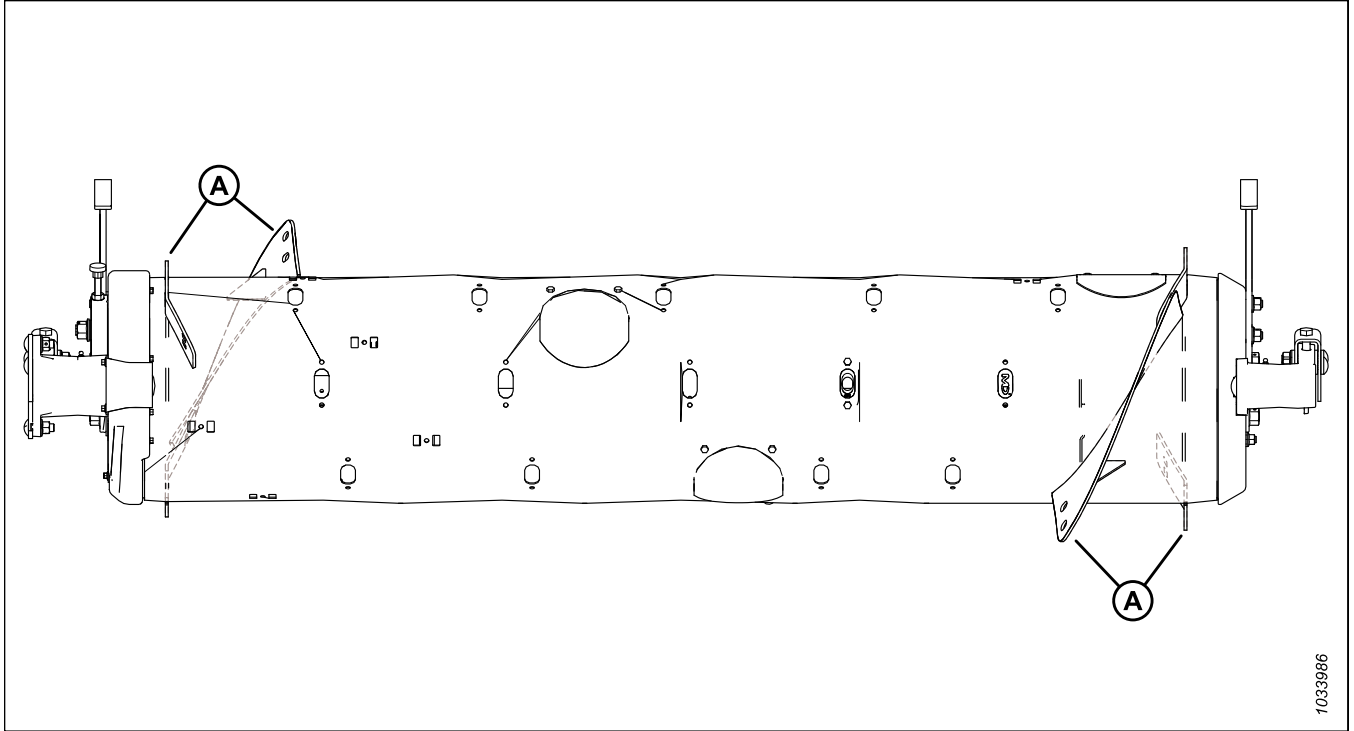
Ultra Wide Configuration uses no bolt-on fighting; only factory-welded fighting is responsible for conveying the crop. A total of 30 auger fingers is recommended for this configuration.

**NOTE:**

This configuration may increase combine capacity on wide feeder house combines in certain crop conditions.



## OPERATION



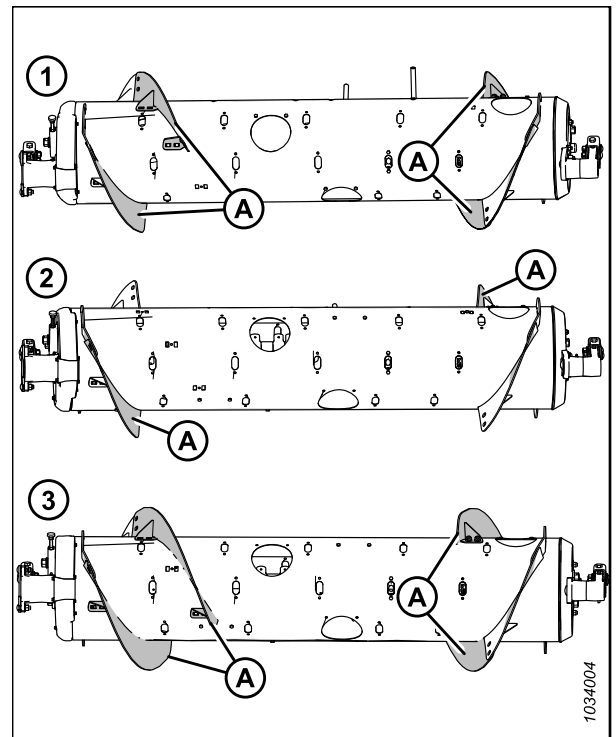
**Figure 3.225: Ultra Wide Configuration**

A - Factory-Welded Flighting

### To convert to Ultra Wide Configuration:

Remove all existing bolt-on flightings (A) from the auger and install additional auger fingers if required. A total of 30 auger fingers is recommended for this configuration.

- For flighting removal instructions, refer to [Removing Bolt-On Flighting, page 174](#).
- For finger installation instructions, refer to [3.8.3 Installing Feed Auger Fingers, page 184](#).



**Figure 3.226: Auger Configurations – Rear View**

1 - Medium Configuration

2 - Wide Configuration

3 - Narrow Configuration

## OPERATION

### Auger Flighting

The auger flighting on the FM200 can be configured for particular harvesting and crop conditions.

For instructions, refer to [3.8.1 FM200 Feed Auger Performance Configurations, page 158](#) for combine/crop specific configurations.

#### Removing Bolt-On Flighting

The feed auger has removable flighting that can be customized to the different models of combines.

Before removing the bolt-on flighting, determine the quantity and the type of flighting required. For more information on the different flighting configurations, refer to [3.8.1 FM200 Feed Auger Performance Configurations, page 158](#).

To remove the bolt-on flighting, follow these steps:

1. To improve access to the feed auger, remove the float module from the combine.
2. Shut down the engine, and remove the key from the ignition.
3. Rotate the auger as needed.

#### NOTE:

The illustrations in this procedure show the feed auger separated from the float module for clarity. The procedure can be performed with the feed auger installed in the float module.

4. Remove bolts (A) and access cover (B). Retain these parts for reassembly. If necessary, remove multiple access covers.

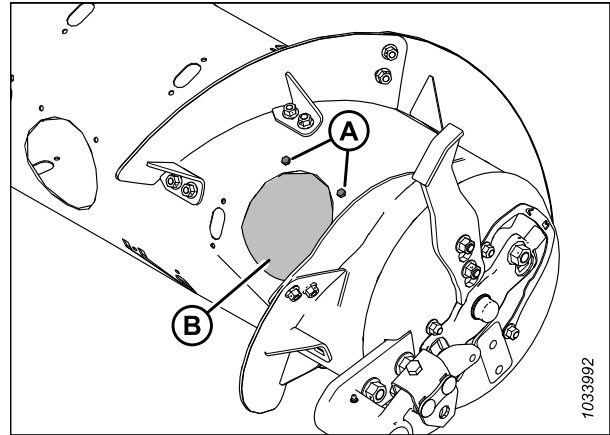


Figure 3.227: Auger Access Cover – Right Side

5. Remove bolts and nuts (B) and remove flighting (A).

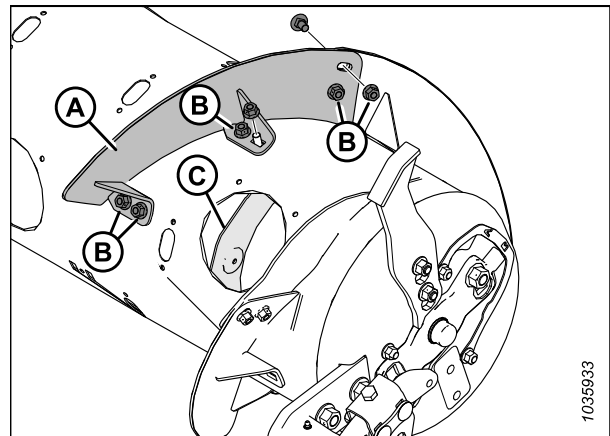


Figure 3.228: Short Flighting – Right Side

## OPERATION

### NOTE:

The illustration shows new long flighting (A) installed.

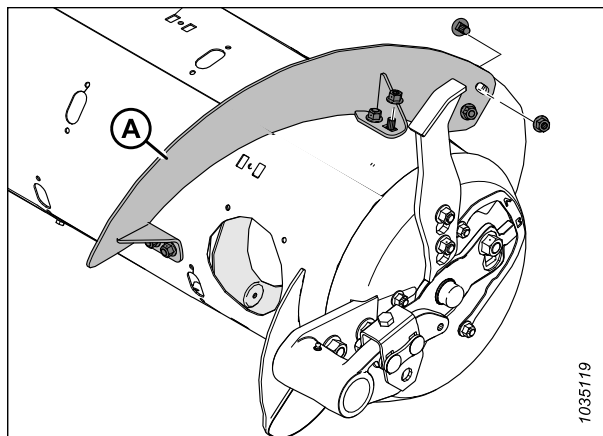


Figure 3.229: Long Flighting – Right Side

6. Install slot plug (A) with M6 bolt (B) and tee nut (C) at each location from which the flighting was removed. Torque the hardware to 9 Nm (6.64 lbf·ft [80 lbf·in]).

### NOTE:

If the plug bolts are **NOT** new, coat them with medium-strength threadlocker (Loctite® 243 or equivalent) before you install them.

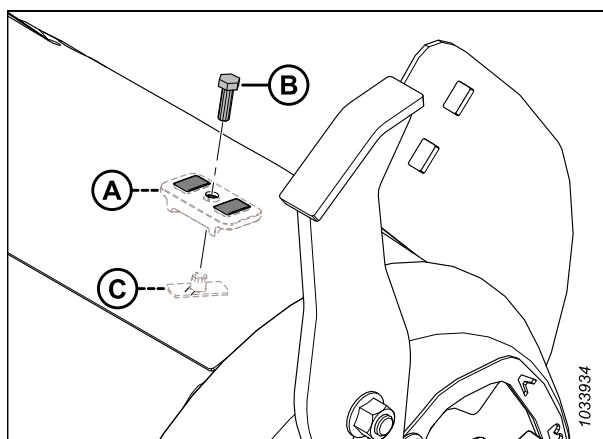


Figure 3.230: Installing Slot Plugs

7. Repeat Step 3, page 174 to Step 6, page 175 to remove flighting (A) from the left side of the auger.

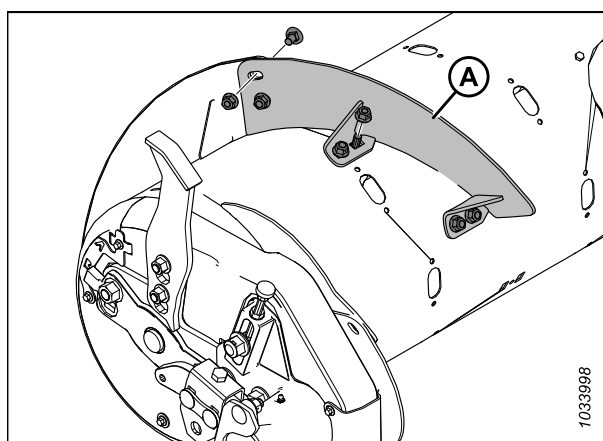


Figure 3.231: Short Flighting – Left Side

## OPERATION

- Reinstall access cover(s) (A) using retained bolts (B) and the welded nuts inside the auger. Coat the bolts with medium-strength threadlocker (Loctite® 243 or equivalent) and torque the hardware to 9 Nm (6.64 lbf·ft [80 lbf·in]).

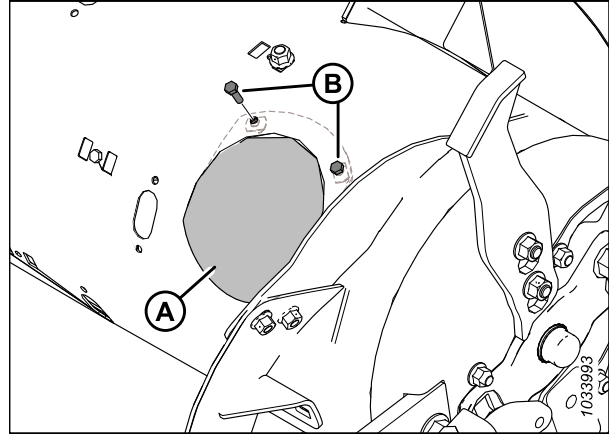


Figure 3.232: Access Cover – Right Side

### Installing Bolt-On Flighting

The feed auger has removable flighting that can be customized to the different models of combines.

Before installing the bolt-on flighting, determine the quantity and the type of flighting required. For more information on the different flighting configurations, refer to [3.8.1 FM200 Feed Auger Performance Configurations, page 158](#).

To install the bolt-on flighting, follow these steps:

- To improve access to the feed auger, remove the float module from the combine.
- Shut down the engine, and remove the key from the ignition.
- Rotate the auger as needed.

#### NOTE:

The illustrations in this procedure show the feed auger separated from the float module for clarity. This procedure can be performed with the feed auger installed in the float module.

- Remove bolts (A) and access cover (B). Retain these parts for reassembly. If necessary, remove multiple access covers.

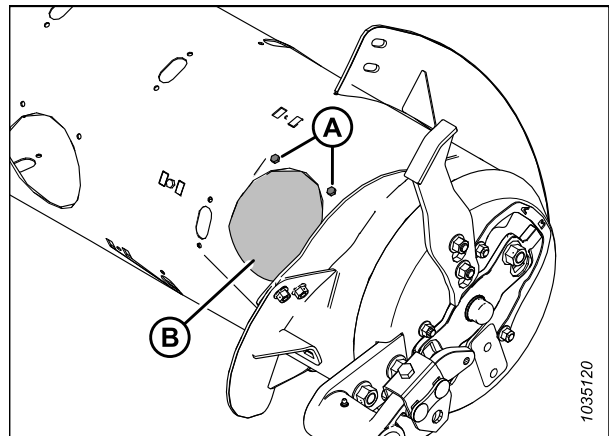


Figure 3.233: Auger Access Cover – Right Side

## OPERATION

5. Align the new bolt-on fighting (A) to determine which slot plugs to remove from the auger. The new fighting overlaps on the outboard side of the adjacent fighting.

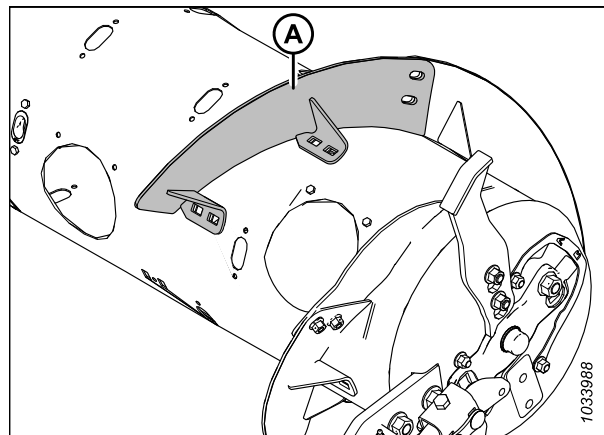


Figure 3.234: Right Side of Auger

6. Remove applicable slot plugs(s) (A).

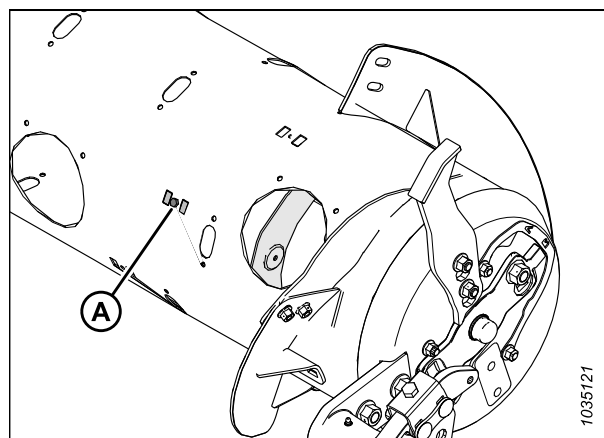


Figure 3.235: Right Side of Auger

7. Install fighting (A) using M10 x 20 mm square neck carriage bolts and center lock nuts at locations (B).

**IMPORTANT:**

The bolt heads must be installed on the inside of the auger to prevent damage to the auger's internal components.

**IMPORTANT:**

The bolts that attach the flightings to each other must have the bolt heads on the inboard (crop side) of the fighting.

8. Torque the six nuts and bolts to 47 Nm (35 lbf-ft) to eliminate deflection on the fighting, then torque them to 61 Nm (45 lbf-ft).

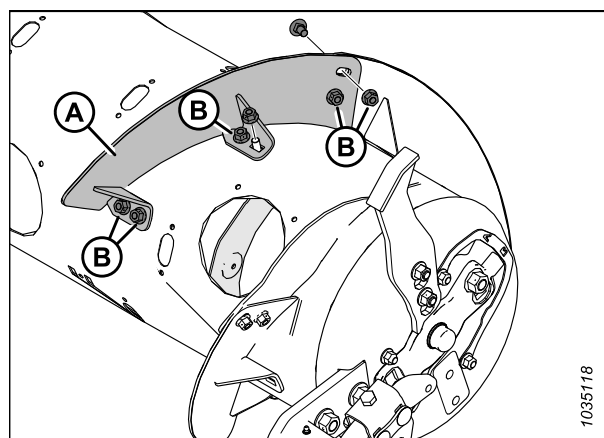


Figure 3.236: Short Fighting – Right Side

## OPERATION

### NOTE:

The illustration shows long flighting (A) installed.

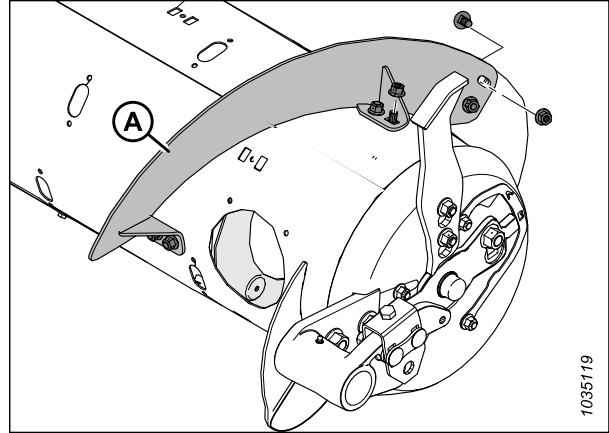


Figure 3.237: Long Flighting – Right Side

9. Repeat Step 3, page 176 to Step 8, page 177 to install flighting (A) on the left side of the auger.

### NOTE:

Flighting performs best when no gaps are present. If desired, use silicone sealant to fill the gaps.

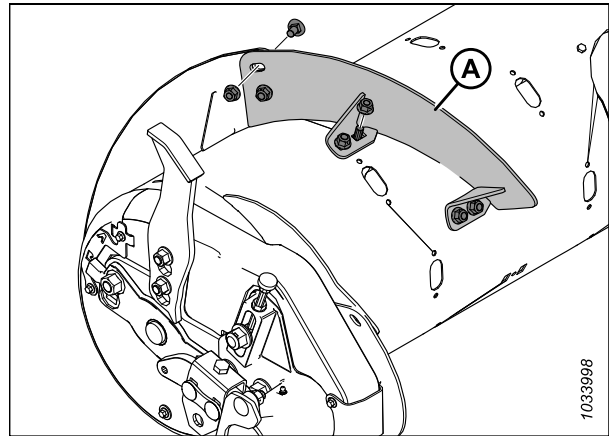


Figure 3.238: Short Flighting – Left Side

10. Reinstall access cover(s) (A) using retained bolts (B) and the welded nuts inside the auger. Coat the bolts with medium-strength threadlocker (Loctite® 243 or equivalent) and torque the hardware to 9 Nm (6.63 lbf·ft [80 lbf·in]).
11. If you are converting the feed auger to an Ultra Narrow configuration and require drilling to install the remaining flighting, proceed to *Installing Additional Bolt-On Flighting – Ultra Narrow Configuration Only*, page 179.

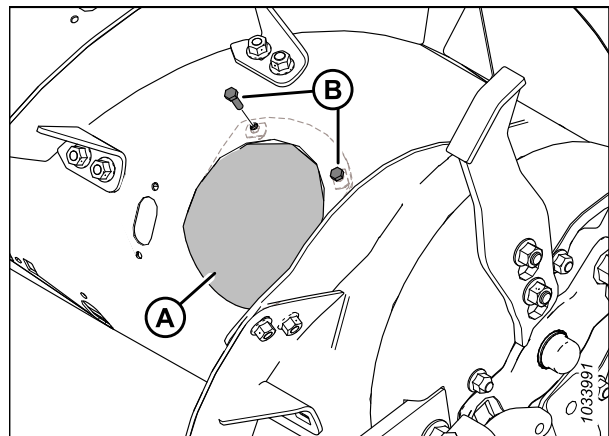


Figure 3.239: Access Cover – Right Side

## OPERATION

### Installing Additional Bolt-On Flighting – Ultra Narrow Configuration Only

When converting the feed auger to an Ultra Narrow configuration, drilling is required to install the additional flighting.

#### NOTE:

This procedure assumes the feed auger is currently in Narrow configuration (4 long flightings [A] installed).

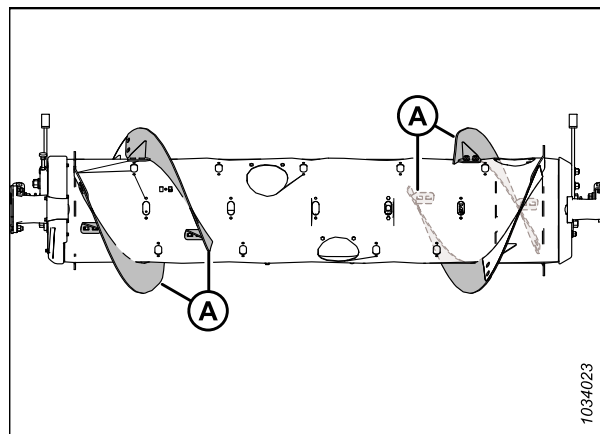


Figure 3.240: Narrow Configuration

To install the four additional long flightings for an Ultra Narrow configuration, follow the steps below:

1. To improve access to the feed auger, remove the float module from the combine.
2. Shut down the engine, and remove the key from the ignition.
3. Rotate the auger as needed.

#### NOTE:

The illustrations in this procedure show the feed auger separated from the float module for clarity. This procedure can be performed with the feed auger installed in the float module.

4. Place new flighting (A) outboard of already installed flighting (B) on the left side of the auger, as shown.
5. Mark hole locations (C) on already installed flighting (B).
6. Remove the nearest access cover to already installed flighting (B). Retain the hardware for reassembly.
7. Remove already installed bolt-on flighting (B) from the auger. Retain the hardware for reassembly.

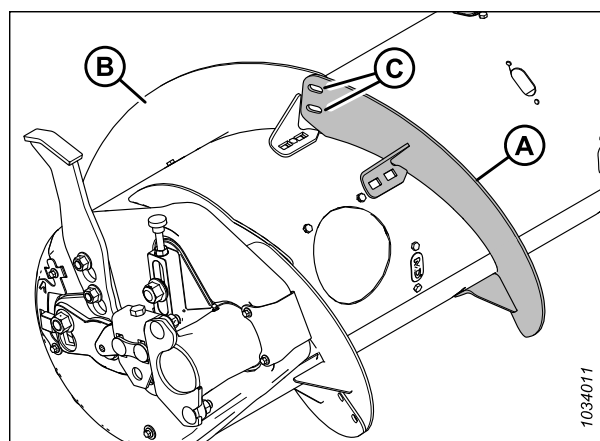


Figure 3.241: Left Side of Auger

## OPERATION

- Drill two 11 mm (7/16 in.) holes at the locations (A) you marked in Step 5, page 179.
- Reinstall the bolt-on flighting.

### IMPORTANT:

Ensure that the carriage bolt heads are on the inside of the auger to prevent damage to the internal components.

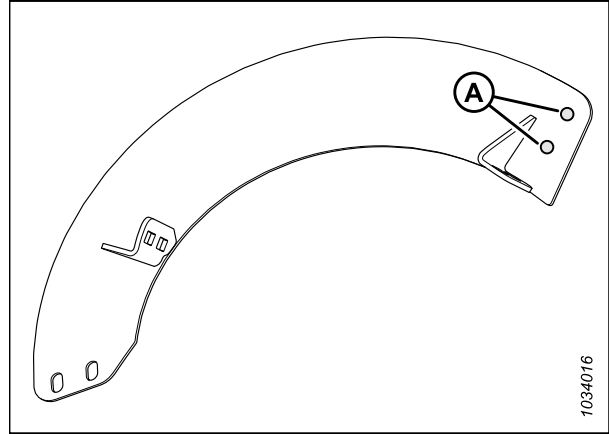


Figure 3.242: Drilling Locations

- Place new flighting (A) into position on the auger, outboard of installed flighting (B).
- Secure the new flighting with two M10 x 20 mm button head bolts and center lock nuts (C).

### IMPORTANT:

Ensure that the bolt heads are on the inboard side (crop side) and the nuts are on the outboard side of the new flighting.

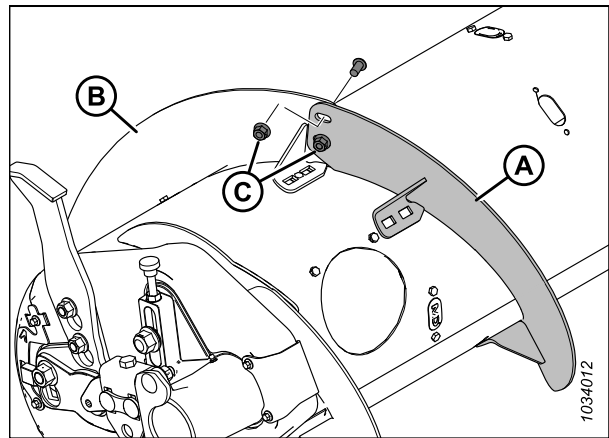


Figure 3.243: Left Side of Auger

- Stretch new flighting (A) to fit the auger tube as shown. Use the slotted holes on the new flighting to best fit the auger tube.

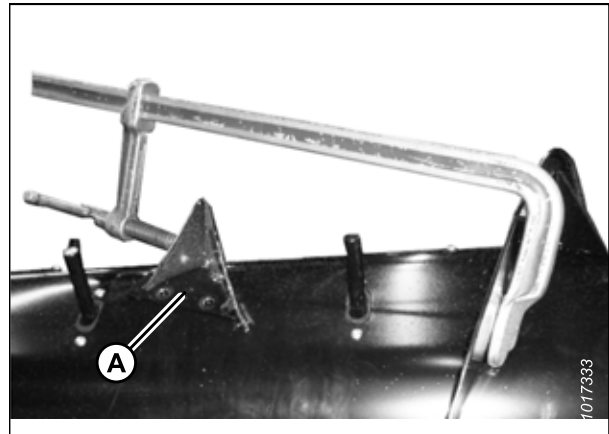


Figure 3.244: Flighting Stretched Axially



## OPERATION

13. Mark four hole locations (A) on the new flighting and drill 11 mm (7/16 in.) holes in the auger tube.

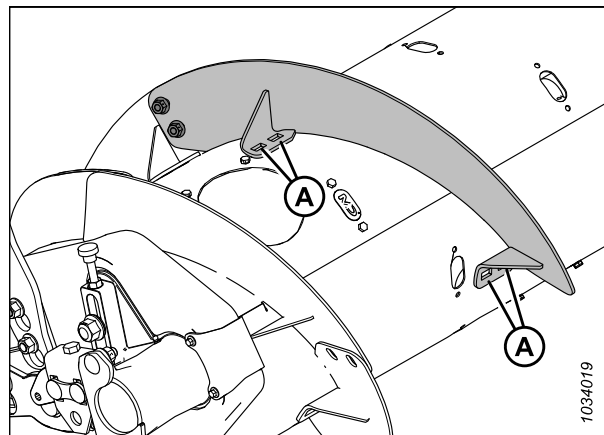


Figure 3.245: Flighting on Left Side of Auger

14. Remove the nearest access cover(s) (B). Retain the cover for reinstallation.
15. Secure the new flighting to the auger at drilled holes (A) using four M10 x 20 mm flange head bolts and center lock nuts.
16. Repeat Step 3, page 179 to Step 15, page 181 for the other flighting on the left side of the auger.
17. Repeat Step 3, page 179 to Step 15, page 181 for both flightings on the right side of the auger.
18. Torque all the flighting nuts and bolts to 47 Nm (35 lbf·ft) to eliminate deflection on the flighting, then torque the nuts and bolts to 61 Nm (45 lbf·ft).

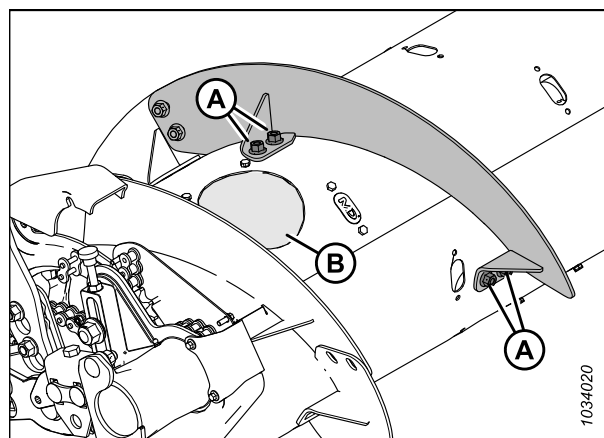


Figure 3.246: Left Side of Auger

### NOTE:

Flighting performs best when there are no gaps between the flighting and the auger drum. If desired, use silicone sealant to fill any gaps.

19. Add or remove auger fingers as necessary to optimize feeding for your combine and crop conditions. For instructions, refer to 3.8.2 *Removing Feed Auger Fingers*, page 181 or 3.8.3 *Installing Feed Auger Fingers*, page 184.
20. If you are not adding or removing auger fingers, reinstall all of the access covers. Coat the retained bolts with medium-strength threadlocker (Loctite® 243 or equivalent), then use the bolts to secure the auger covers. Torque the bolts to 9 Nm (6.64 lbf·ft [80 lbf·in]).

## 3.8.2 Removing Feed Auger Fingers

The feed auger uses fingers to bring crop into the feeder house. The quantity of fingers varies for the different models of combines.



### DANGER

Ensure that all bystanders have cleared the area.

## OPERATION

### WARNING

To prevent bodily injury from the fall of a raised reel, always engage the reel safety props before going under the raised reel for any reason.

#### IMPORTANT:

Remove the auger fingers from the feed auger from outside inward. Make sure that there is an equal number of fingers on each side of the auger.

1. Start the engine.
2. Raise the reel fully.
3. Shut down the engine, and remove the key from the ignition.
4. Engage the reel safety props. For instructions, refer to *Engaging Reel Safety Props, page 39*.
5. Remove bolts (A) and access cover (B) closest to the finger you are removing. Retain the parts for reinstallation.

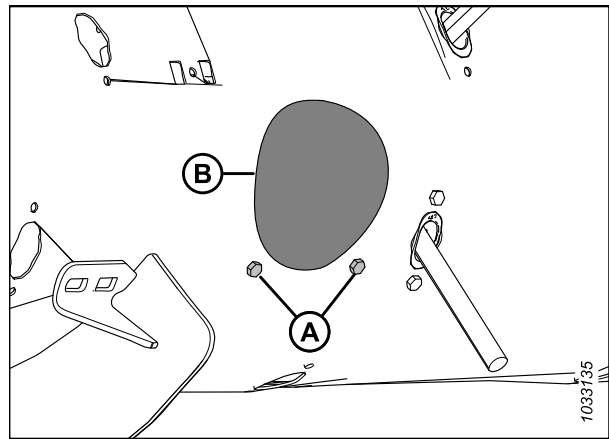


Figure 3.247: Auger Access Hole Cover

6. Remove the auger finger as follows:
  - a. Remove hairpin (A).
  - b. Pull finger (B) out of finger holder (C).
  - c. Push finger (B) through guide (D) and into the drum.
  - d. Pull the finger out of the drum access hole.

#### NOTE:

If the auger finger is broken, remove any remnants from holder (C) and from inside the drum.

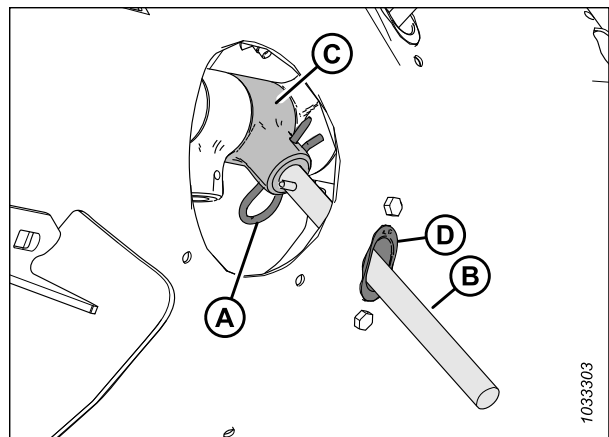


Figure 3.248: Auger Finger

## OPERATION

7. Remove and retain two bolts (A) and tee nuts (not shown) securing finger guide (B) to the auger.
8. Remove guide (B).

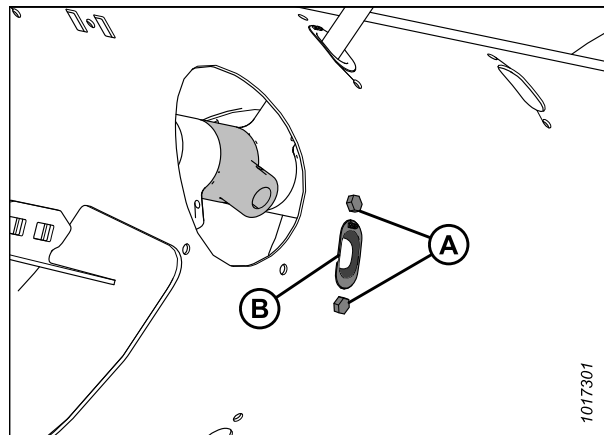


Figure 3.249: Auger Finger Hole

9. Position plug (A) into the hole from inside the auger. Secure the plug with two M6 hex head bolts (B) and tee nuts. Torque the hardware to 9 Nm (6.6 lbf-ft [80 lbf-in]).

**NOTE:**

Bolts (B) come with a threadlocker patch that will wear off if the bolts are removed. If reinstalling bolts (B), apply medium-strength threadlocker (Loctite® 243 or equivalent) before you reinstall the bolts.

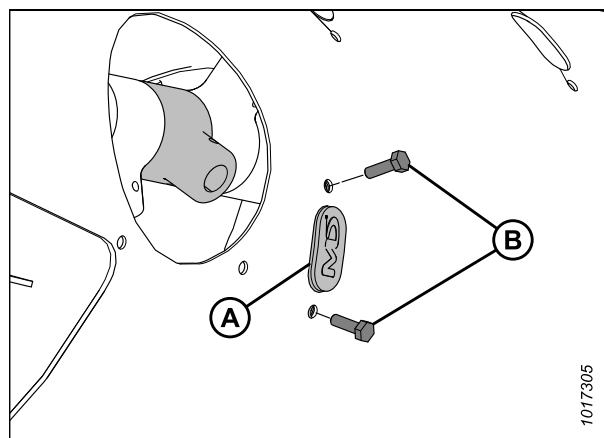


Figure 3.250: Plug

10. Secure access cover (B) in place with bolts (A). Torque the bolts to 9 Nm (6.6 lbf-ft [80 lbf-in]).

**NOTE:**

Bolts (A) come with a threadlocker patch that will wear off if the bolts are removed. If reinstalling bolts (A), apply medium-strength threadlocker (Loctite® 243 or equivalent) before you reinstall the bolts.

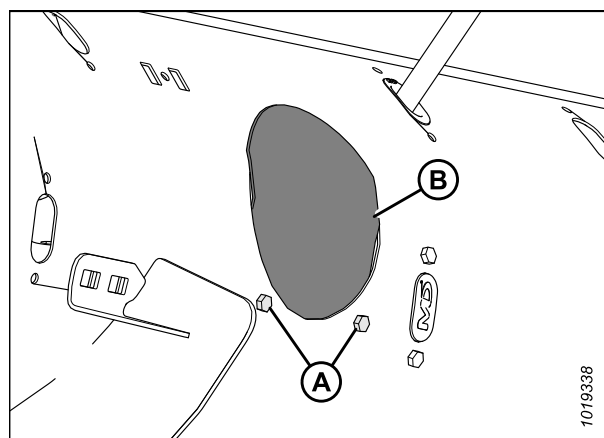


Figure 3.251: Auger Access Hole Cover

### 3.8.3 Installing Feed Auger Fingers

The feed auger uses fingers to bring the crop into the feeder house. The quantity of fingers varies for the different models of combines.

**⚠ DANGER**

Ensure that all bystanders have cleared the area.

**⚠ WARNING**

To prevent bodily injury from the fall of a raised reel, always engage the reel safety props before going under the raised reel for any reason.

**IMPORTANT:**

Ensure that you install an equal number of auger fingers on each side of the auger.

1. Raise the reel fully.
2. Shut down the engine, and remove the key from the ignition.
3. Engage the reel safety props. For instructions, refer to *Engaging Reel Safety Props, page 39*.
4. Insert guide (B) from inside of the auger and secure it with bolts (A) and tee nuts (not shown).

**IMPORTANT:**

Always install a new guide when replacing a solid finger.

**NOTE:**

Bolts (A) come with a threadlocker patch that will wear off if the bolts are removed. If you are reinstalling bolts (A), apply medium-strength threadlocker (Loctite® 243 or equivalent) to the threads of the bolts before reinstallation.

5. Torque bolts (A) to 9 Nm (6.6 lbf·ft [80 lbf·in]).

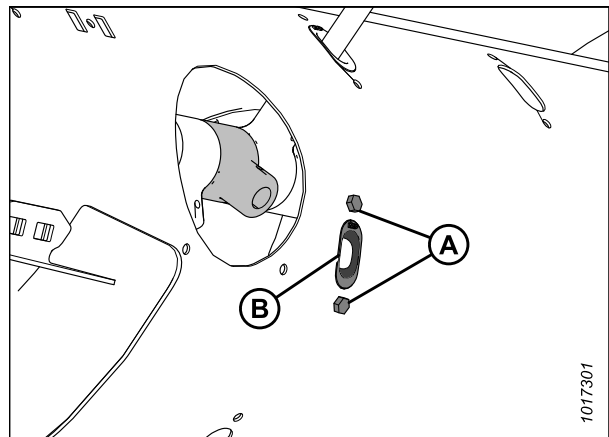


Figure 3.252: Auger Finger Hole

6. Install auger finger (A) inside the drum. Insert one end of auger finger (A) up through the bottom of guide (B) and insert the other end of the finger into holder (C).
7. Secure the finger by inserting hairpin (D) into the holder. Make sure the round end (the S-shaped side) of the hairpin faces the chain drive side of the auger. Make sure the closed end of the hairpin points in the direction of auger-forward rotation.

**IMPORTANT:**

Position the hairpin as described in this step to prevent the hairpin from falling out during operation. If the fingers are lost, the header might not be able to feed the crop into the combine properly. Furthermore, fingers that fall into the drum might damage the auger's internal components.

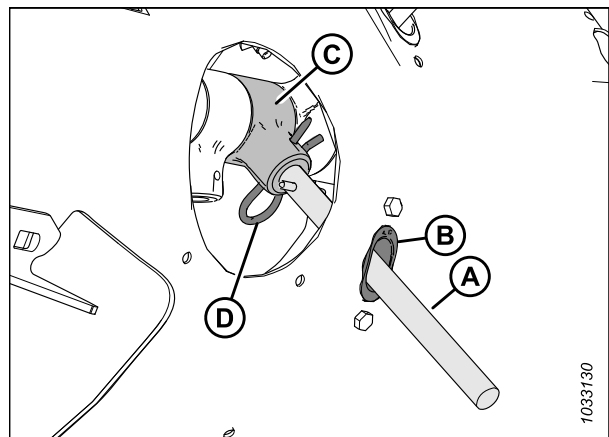


Figure 3.253: Auger Finger

## OPERATION

- Secure access cover (B) in place with bolts (A). Torque the bolts to 9 Nm (6.64 lbf-ft [80 lbf-in]).

### NOTE:

Bolts (A) come with a threadlocker patch that will wear off if the bolts are removed. If you are reinstalling bolts (A), apply medium-strength threadlocker (Loctite® 243 or equivalent) to the threads of the bolts before reinstallation.

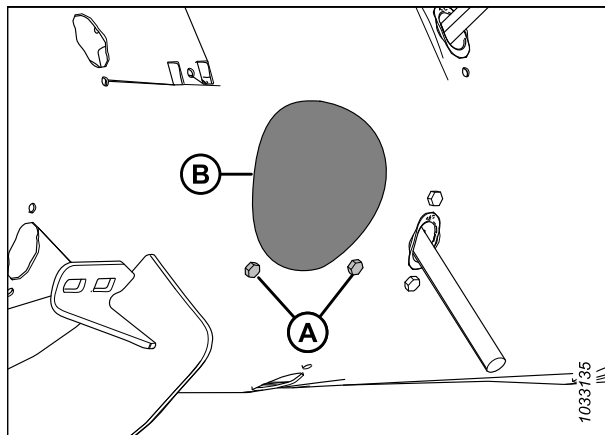


Figure 3.254: Auger Access Hole Cover

### 3.8.4 Setting Auger Position

The auger position has two settings: floating and fixed. The factory setting is the floating position, and it is recommended for most crop conditions.

Auger float adjustment arms (A) are located at the bottom left and bottom right of the float module.

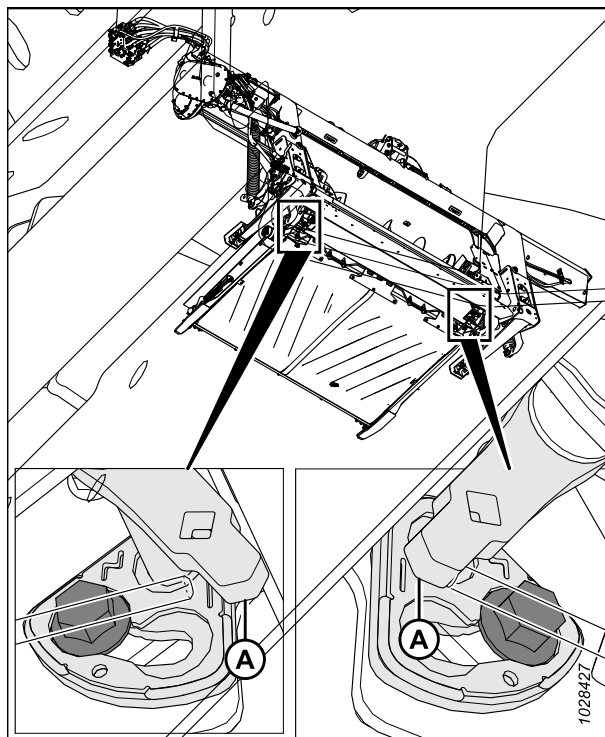


Figure 3.255: Auger Float Adjustment Arms

## OPERATION

If bolt (A) is next to floating symbol (B), the auger is in the floating position. If bolt (A) is next to fixed symbol (C), the auger is in the fixed position.

### CAUTION

Make sure the left and the right brackets are set to the same position; two bolts (A) must be in the same location to prevent damage to the machine during operation.

### DANGER

To prevent bodily injury or death from the unexpected start-up or fall of a raised machine, always stop the engine, remove the key, and engage the safety props before going under the header for any reason.

### DANGER

Ensure that all bystanders have cleared the area.

To set the auger position, follow these steps:

1. Start the engine.
2. Raise the header fully.
3. Engage the header safety props. For instructions, refer to the combine operator's manual.
4. Shut down the engine, and remove the key from the ignition.
5. Using a 21 mm wrench, loosen bolt (A) until the bolt head is clear of bracket (B).

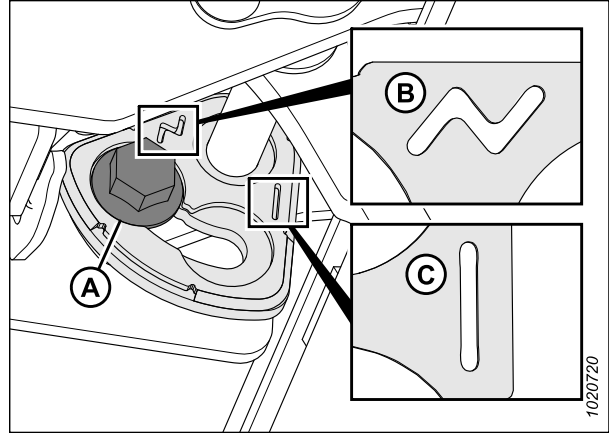


Figure 3.256: Auger Float Positions

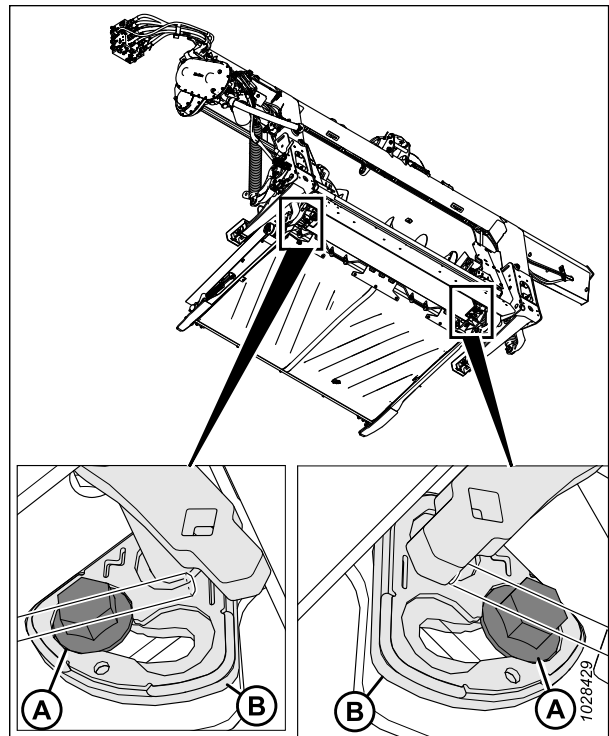


Figure 3.257: Feed Auger Float Adjustment

## OPERATION

- Using a breaker bar in the square hole on arm (B), move arm (B) forward until bolt (A) is in the slot on the bracket next to the fixed symbol.

### NOTE:

If you are changing the auger position from fixed to floating, move the arm in the opposite direction.

- Tighten bolt (A) to 122 Nm (90 lbf·ft).

### IMPORTANT:

Bolt (A) must be properly seated in the recess on the bracket before tightening the bolt. If arm (B) can be moved after tightening the bolt, then bolt (A) is not seated properly.

- Repeat Step 5, page 186 to Step 7, page 187 on the opposite side.

### IMPORTANT:

Bolt (A) on each side of the float module must be in the same position to prevent damage to the machine during operation.

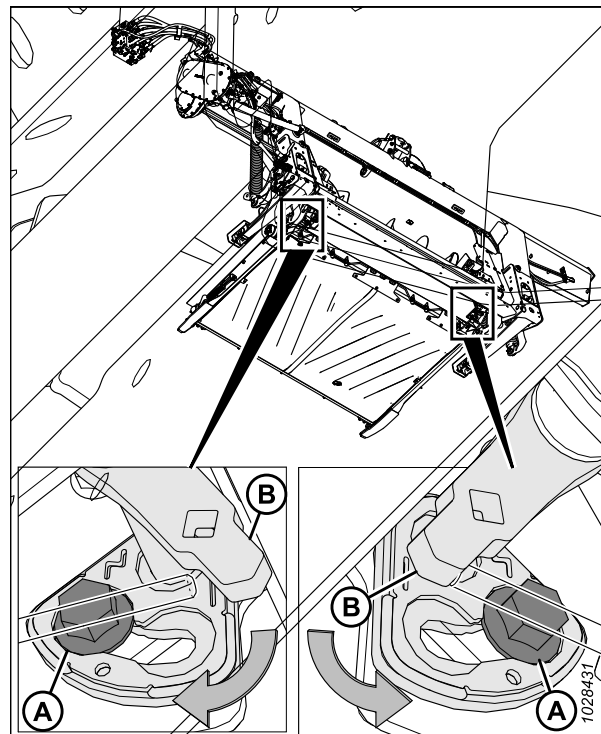


Figure 3.258: Feed Auger Float Adjustment

### 3.8.5 Checking and Adjusting Feed Auger Springs

The feed auger has an adjustable spring tensioning system that allows the auger to float on top of the crop instead of crushing and damaging it. The factory-set tension is adequate for most crop conditions.

#### DANGER

To prevent bodily injury or death from the unexpected start-up or fall of a raised machine, always stop the engine, remove the key, and engage the safety props before going under the header for any reason.

#### DANGER

Ensure that all bystanders have cleared the area.

- Start the engine.
- Raise the header fully.
- Shut down the engine, and remove the key from the ignition.
- Engage the header safety props. For instructions, refer to the combine operator's manual.

## OPERATION

5. Check the thread length protruding past nut (A). The length should be 22–26 mm (7/8–1 in.).

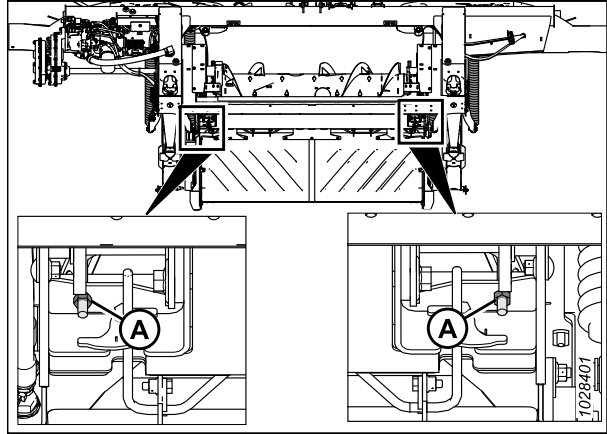


Figure 3.259: Spring Tensioner

*If adjustment is required, follow these steps:*

6. Loosen upper jam nut (A) on the spring tensioner.

**NOTE:**

The upper jam nut is located on other side of the plate.

7. Turn lower nut (B) until thread (C) protrudes 22–26 mm (7/8–1 in.).
8. Tighten jam nut (A).
9. Repeat Steps 6, [page 188](#) to 8, [page 188](#) on the opposite side.

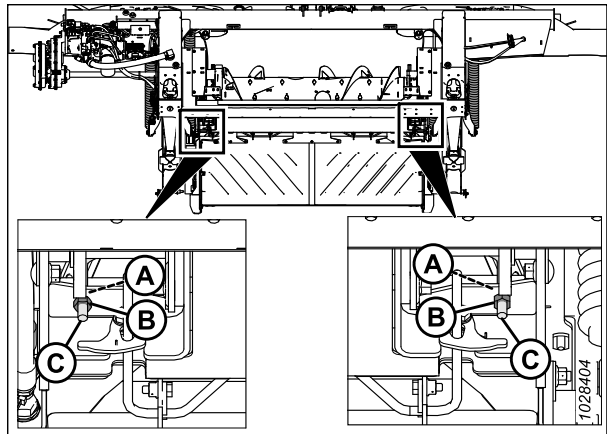


Figure 3.260: Spring Tensioner

### 3.8.6 Stripper Bars

A stripper bar kit may have been supplied with your header. Installing the stripper bar kit improves feeding in certain crops, such as rice.

For information on removing and installing the stripper bars, refer to [4.11 Stripper Bars, page 696](#).



### 3.9 Header Operating Variables

The header can be adjusted to affect its performance.

Correctly adjusting the header will reduce crop loss and speed up harvesting. Proper adjustments, along with timely maintenance, will also increase the service life of the header.

Most of the settings below have been configured at the factory, but they can be changed for various crops and/or different harvesting conditions.

**Table 3.15 Operating Variables**

Variable	Refer to
Feed auger configurations	<a href="#">3.8.1 FM200 Feed Auger Performance Configurations, page 158</a>
Cutting height	<a href="#">3.9.1 Cutting off Ground, page 189</a> <a href="#">3.9.2 Cutting on Ground, page 207</a>
Header float	<a href="#">3.9.3 Header Float, page 209</a>
Header angle	<a href="#">3.9.5 Header Angle, page 232</a>
Reel speed	<a href="#">3.9.6 Reel Speed, page 240</a>
Ground speed	<a href="#">3.9.7 Ground Speed, page 242</a>
Draper speed	<a href="#">3.9.8 Side Draper Speed, page 243</a>
Knife speed	<a href="#">3.9.10 Knife Speed Information, page 245</a>
Reel height	<a href="#">3.9.11 Reel Height, page 247</a>
Reel fore-aft position	<a href="#">3.9.12 Reel Fore-Aft Position, page 252</a>
Reel tine pitch	<a href="#">3.9.13 Reel Tine Pitch, page 261</a>
Crop divider rods	<a href="#">3.9.15 Crop Dividers, page 268</a>

#### 3.9.1 Cutting off Ground

The header's design allows you to cut crop above the ground, which results in stubble being cut to a uniform height.

When cutting crop above ground level:

- Use the stabilizer wheels on the header (if this optional component is installed) to set the cutting height. The stabilizer wheel system is designed to minimize bouncing at the ends of the header and the system may be used to float the header to achieve an even cutting height when cutting above the ground in cereal grains.

**NOTE:**

Lock the header wings when using the stabilizer wheel system.

- Contour wheels provide consistent cutting height information back to the header so it can flex, maintain an accurate and consistent cutting height, and still use the combine's auto height control seamlessly. The wheels contact the ground, allowing the cutterbar to remain at a fixed height even through rolling contours. There is no need to adjust the factory auto height control settings.

**NOTE:**

Lock the header wings when using contour wheels.

The cutting height is controlled by the combine header height control.

If the Stabilizer Wheels kit is installed, refer to [Adjusting Stabilizer Wheels, page 190](#) to change the wheel position.

If the EasyMove™ Transport option is installed, refer to [Adjusting EasyMove™ Transport Wheels, page 191](#) to change the wheel position.

If ContourMax™ Contour Wheels are installed, refer to [Extending/Retracting Contour Wheels using Foot Switch, page 192](#) to change the wheel position.

## OPERATION

### Adjusting Stabilizer Wheels

A properly adjusted header will achieve a balance between the amount of header weight carried by the float and the amount of header weight carried by the stabilizer wheels.

Refer to [3.7.2 Header Settings, page 141](#) for recommended use in specific crops and crop conditions.

#### NOTE:

If the stubble is uneven when cutting off the ground on stabilizer wheels (and other header leveling problems have been eliminated), then adjust the float until the stubble height is even as follows:

- On the side of the header where the stubble is high, loosen the float springs (make the header heavier).
- On the side of the header where the stubble is low, tighten the float springs (make the header lighter).

#### IMPORTANT:

When cutting on the ground, set the float using the standard float adjustment procedure. Poor performance and potential wear will occur if you use the stabilizer wheels' float settings when cutting on the ground.

### DANGER

To prevent injury or death from the unexpected start-up of the machine, always stop the engine and remove the key from the ignition before leaving the operator's seat for any reason.

### DANGER

Ensure that all bystanders have cleared the area.

1. Raise the header until the stabilizer wheels are off the ground.
2. Shut down the engine, and remove the key from the ignition.
3. Hold axle pivot handle (B); do **NOT** lift the handle.

#### NOTE:

Lifting the handle will make it more difficult to take the system out of slot (C).

4. Pull suspension handle (A) rearward to remove the pin from slot (C).
5. Lift the wheel to the desired height position using axle pivot handle (B), and engage the support channel into center slot (C) in the upper support.
6. Suspension handle (A) should snap into the slot. If the suspension handle does not snap in, push (for middle or lower position) or pull in (for top position) the suspension handle to ensure that it is seated in the slot.
7. Use the combine's auto header height control (AHHC) to automatically maintain the cutting height. For instructions, refer to [Auto Header Height Control System, page 290](#) and your combine operator's manual for details.

#### NOTE:

The height sensor on the FM200 Float Module must be connected to the combine height control system in the cab.

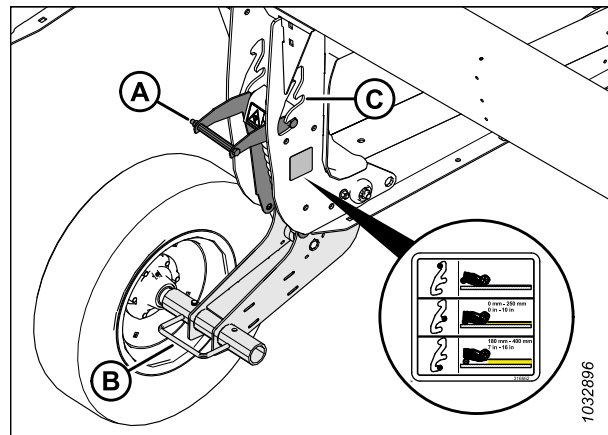


Figure 3.261: Stabilizer Wheel

## OPERATION

### Adjusting EasyMove™ Transport Wheels

A properly adjusted header will achieve a balance between the amount of header weight carried by the float and the amount of header weight carried by the transport wheels.

#### DANGER

To prevent injury or death from the unexpected start-up of the machine, always stop the engine and remove the key from the ignition before leaving the operator's seat for any reason.

#### DANGER

Ensure that all bystanders have cleared the area.

1. Raise the header so that the transport wheels are off the ground.
2. Shut down the engine, and remove the key from the ignition.
3. Ensure that the float is working properly. For instructions, refer to [Checking and Adjusting Header Float, page 210](#).

4. Hold axle pivot handle (C); do **NOT** lift the handle.

#### NOTE:

Lifting the handle will make it more difficult to take the system out of slot (B).

5. Pull suspension handle (A) rearward to remove the pin from slot (B).
6. Adjust the wheel to the desired slot position.
7. Suspension handle (A) should snap into the slot. If the suspension handle does not snap in, push (for middle position) or pull in (for top position) the suspension handle to ensure that it is seated in the slot.

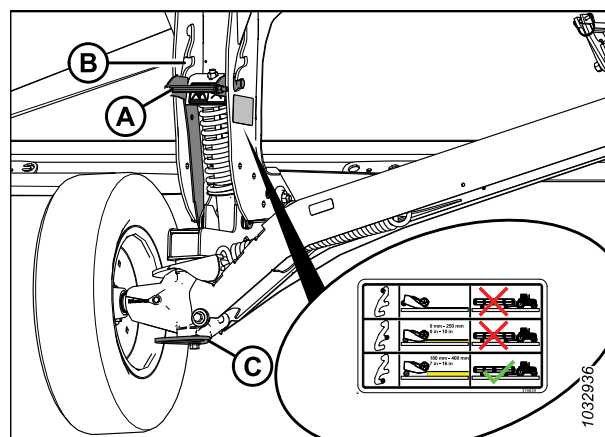


Figure 3.262: Right Wheel

8. Hold axle pivot handle (A); do **NOT** lift the handle.

#### NOTE:

Lifting the handle will make it more difficult to take the system out of the slot.

9. Pull suspension handle (B) rearward to remove the pin from the slot.
10. Adjust the wheel to the desired slot position.
11. Suspension handle (B) should snap into the slot. If the handle does not snap in, pull out the suspension handle to ensure that it is seated in the slot.

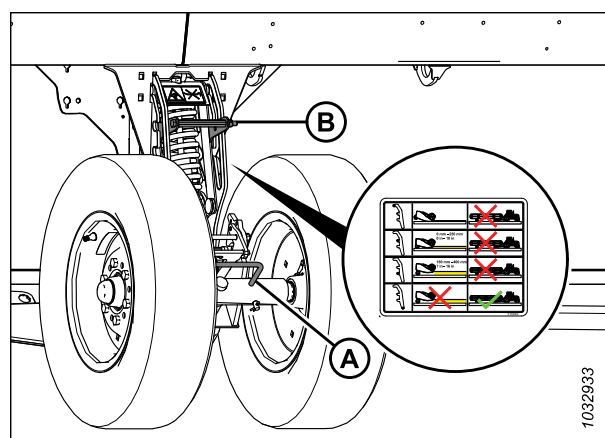


Figure 3.263: Left Wheel

12. Use the combine's auto header height control (AHHC) to automatically maintain the cutting height. For instructions, refer to [Auto Header Height Control System, page 290](#) and your combine operator's manual.

#### NOTE:

The height sensor on the FM200 Float Module must be connected to the combine header control module in the cab.

## OPERATION

### *Extending/Retracting Contour Wheels using Foot Switch*

The contour wheels allow the header to follow the contours of the ground, and can be adjusted between 25 mm (1 in.) and 457 mm (18 in.) from the ground surface. A foot switch allows the wheels to be controlled from the combine cab.

**NOTE:**

If the combine is capable of operating the contour wheels using native combine controls, a foot switch is not used. For more information, refer to Table 3.16, page 192.

**Table 3.16 Controls Used for Operating Contour Wheels according to Combine Brand**

Combine Brand	Controls Used for Operating Contour Wheels
Case	Foot switch or native combine controls, depending on the model of combine and version of software installed. For instructions on using the native combine controls, refer to <i>Extending/Retracting Contour Wheels using Integrated Controls – Case and New Holland, page 193</i> .
CLAAS 600 and 700 Series	Foot switch or native combine controls, depending on the model of combine. For instructions on using the native combine controls, refer to <i>Extending/Retracting Contour Wheels – CLAAS Lexion 600/700 Series, page 196</i> .
CLAAS 8000 Series	Foot switch or native combine controls, depending on the model of combine. For instructions on using the native combine controls, refer to <i>Extending and Retracting Contour Wheels – CLAAS Lexion 8000 Series, page 200</i> .
Challenger®, Gleaner®, Massey Ferguson®	Foot switch required
IDEAL™	Foot switch required
John Deere T, 60/70, and S Series	Foot switch required
John Deere X9 Series	Native combine controls only. For instructions, refer to <i>Extending/Retracting Contour Wheels using Integrated Controls – John Deere X9 Series, page 201</i> .
New Holland	Foot switch or native combine controls, depending on the model of combine and version of software installed. For instructions on using the native combine controls, refer to <i>Extending/Retracting Contour Wheels using Integrated Controls – Case and New Holland, page 193</i> .
Rostselmash	Foot switch required

 **DANGER**

Ensure that all bystanders have cleared the area.

1. Start the engine.
2. Press and hold the foot switch to activate the contour wheels.

**NOTE:**

When the contour wheels foot switch is activated and the reel fore-aft button on the combine’s multifunction handle is pressed, the contour wheels will move regardless of the fore-aft / header tilt switch position.

3. To properly phase the hydraulic cylinders, press and hold the REEL AFT button on the combine multifunction handle to extend the wheels all the way down, then hold the button for 30 seconds.
4. Press and hold the REEL FORE button on the combine multifunction handle to fully retract the wheels, then hold the button for 30 seconds.
5. Operate the hydraulic controls on the multifunction handle to move the wheels to the desired height.
6. Release the foot switch to deactivate the contour wheels. The header tilt and the fore-aft functions should operate normally.

## OPERATION

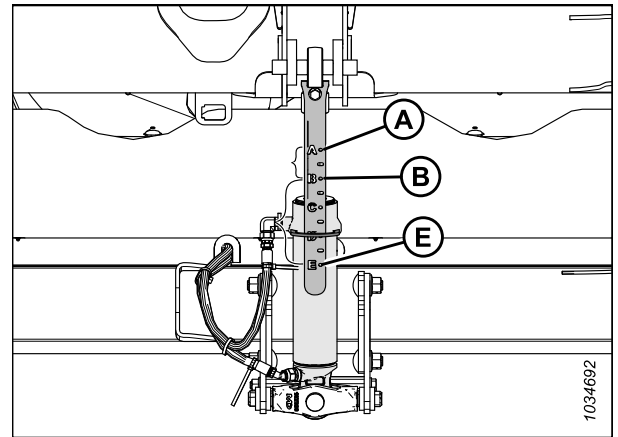
The following table describes what functionality the reel fore/aft buttons will have on the header when the contour wheel foot switch and the fore-aft/header tilt switch are in various (active/inactive) states. The X indicates a switch is active.

**Table 3.17 Control Logic Chart**

Activated Switch				
ContourMax™ Foot Switch Condition	Fore-Aft / Header Angle Switch Position		Combine Multifunction Handle Controls	
	Fore-Aft	Angle	Reel Fore	Reel Aft
—	X	—	Reel forward	Reel back
—	—	X	Header angle extend	Header angle retract
X	—	X	Contour wheel retract (decreases the cut height)	Contour wheel extend (increases the cut height)
X	X	—		

**NOTE:**

When the contour wheels are fully retracted, the cutterbar can be on the ground when the header angle is set approximately between (B) and (E); the contour wheels will contact the ground when the header angle is set between (A) and (B).



**Figure 3.264: Header Angle Indicator**

### *Extending/Retracting Contour Wheels using Integrated Controls – Case and New Holland*

The height of the contour wheels can be adjusted using the multifunction handle.

**⚠ DANGER**

Ensure that all bystanders have cleared the area.

**NOTE:**

Changes may have been made to the combine controls or the display since this document was published. For the most up-to-date information, refer to the combine operator’s manual.

## OPERATION

To raise or lower the contour wheels, press SHIFT (A) and REEL RAISE/LOWER buttons (B).



Figure 3.265: Multifunction Handle – Case



Figure 3.266: Multifunction Handle – New Holland

### *Extending/Retracting Contour Wheels using Integrated Controls – CLAAS Lexion 600/700 Series*

All header functions controlled by the combine's multifunction lever toggle switch will be available only when the header function switch is in the VARIO table extend/retract position.

Move header function switch (A) to the VARIO table extend/retract position to enable the combine's multifunction lever header control functions.



Figure 3.267: Header Function Switch

**Selecting the Default Function for the Multifunction Lever Toggle Switch (with CLAAS Integration Kit)**

The default function for the multifunction lever toggle switch is selectable. For example, when cutting on the ground, the default function can be set so that the multifunction lever's toggle switch activates the pitch control cylinder. Likewise, when cutting off the ground, the default function can be changed so that the toggle switch controls the contour wheels.

**⚠ DANGER**

Ensure that all bystanders have cleared the area.

**NOTE:**

Changes may have been made to the combine controls or the display since this document was published. For the most up-to-date information, refer to the combine operator's manual.

**To select pitch control as the default toggle function:**

1. **If the combine is equipped with a standard lever:**  
While pressing the REEL FORE button, push toggle (A) up. Hold the toggle and the button for 30 seconds.

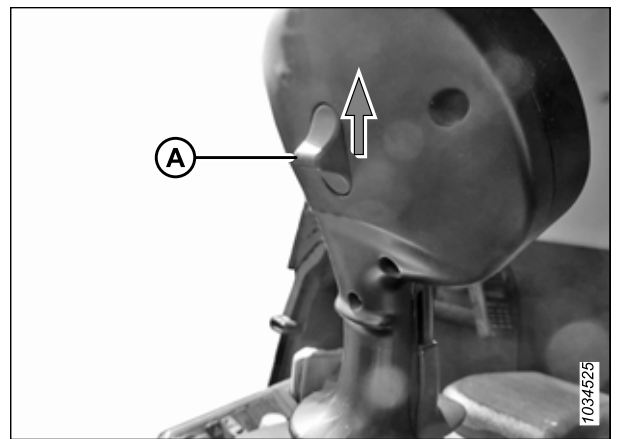


Figure 3.268: Standard Lever

2. **If the combine is equipped with a CMOTION multifunction lever:** While pressing the REEL FORE button, pull multifunction lever toggle switch (A) toward you. Hold the toggle and the button for 30 seconds.

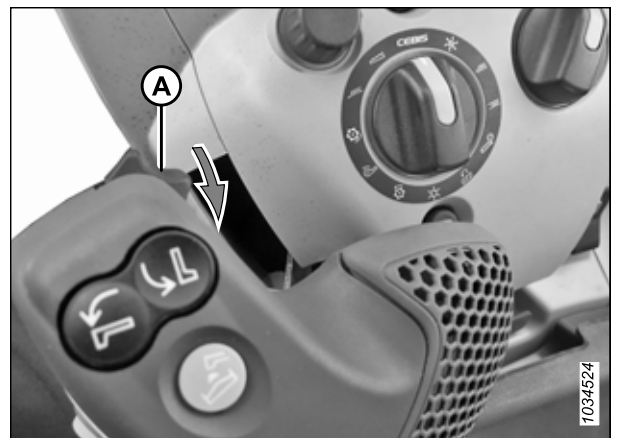


Figure 3.269: CMOTION Lever



## OPERATION

### *To select contour wheel as the default toggle function:*

3. **If the combine is equipped with a standard lever:**  
While pressing the REEL AFT button, push toggle (A) up. Hold the toggle and the button for 30 seconds.

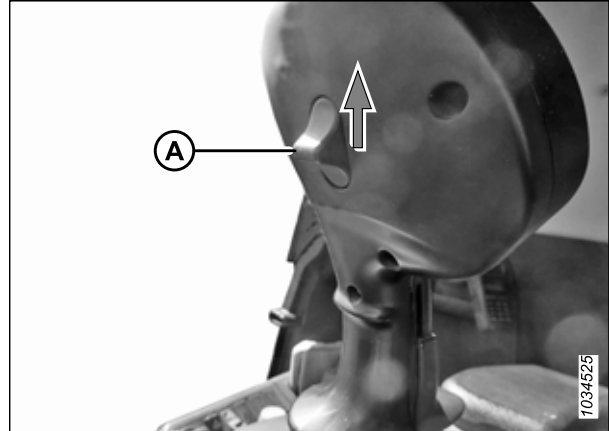


Figure 3.270: Standard Lever

4. **If the combine is equipped with a CMOTION multifunction lever:** While pressing the REEL AFT button, pull multifunction lever toggle switch (A) toward you. Hold the toggle and the button for 30 seconds.

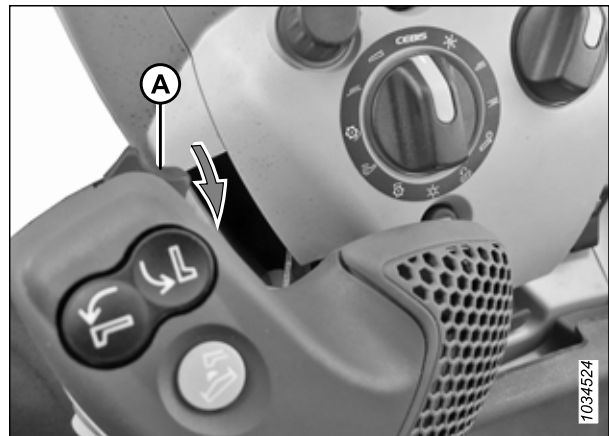


Figure 3.271: CMOTION Lever

### **Extending/Retracting Contour Wheels – CLAAS Lexion 600/700 Series**

The contour wheels can be controlled using the multifunction lever toggle switch, or a combination of the toggle switch and the reel fore-aft button, depending on what is set as the default toggle function.

### **⚠ DANGER**

Ensure that all bystanders have cleared the area.

### **NOTE:**

Changes may have been made to the combine controls or the display since this document was published. For the most up-to-date information, refer to the combine operator's manual.



## OPERATION

1. Move HOTKEY switch (A) on the operator's console to the deck plate position (header icon [A] with the arrows pointing to each other).

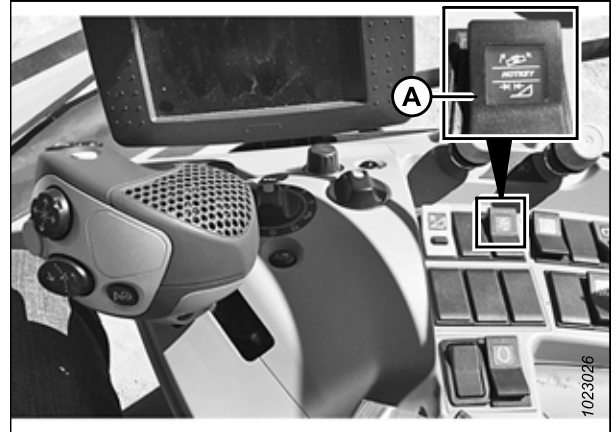


Figure 3.272: Multifunction Lever Toggle Switch

### *Adjusting contour wheels when pitch control is selected as default function*

2. **If the combine is equipped with the CMOTION lever:** pull toggle switch (A) toward you while simultaneously pressing the REEL FORE-AFT button.
  - The reel fore function will retract the contour wheels, decreasing the cut height.
  - The reel aft function will extend the contour wheels, increasing the cut height.

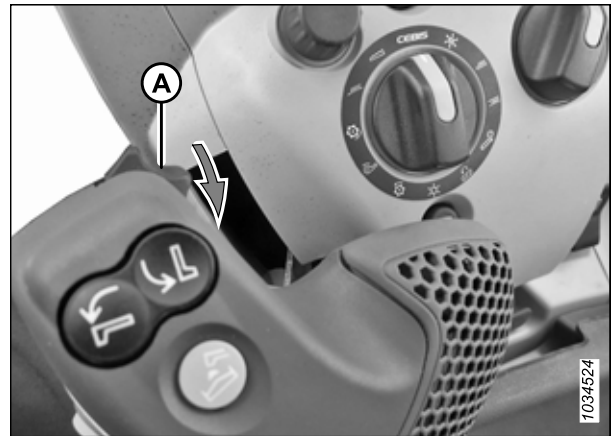


Figure 3.273: CMOTION Lever

3. **If the combine is equipped with the standard lever:** push toggle (A) up while simultaneously pressing the REEL FORE-AFT button.
  - The reel fore function will retract the contour wheels, decreasing the cut height.
  - The reel aft function will extend the contour wheels, increasing the cut height.

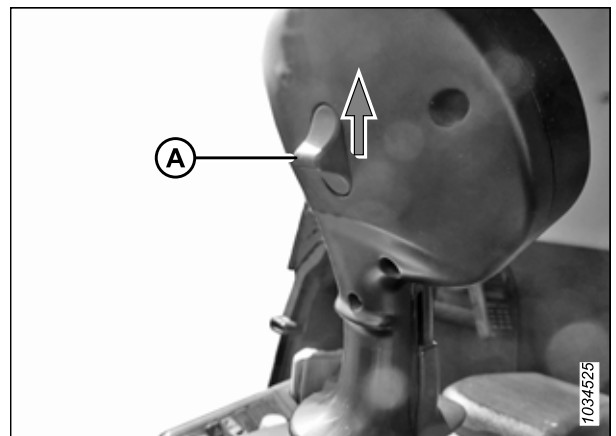


Figure 3.274: Standard Lever

## OPERATION

### *Adjusting contour wheels when contour wheel is selected as default function*

4. **If the combine is equipped with the CMOTION lever:**

- Push toggle switch (C) away from you (direction [A]) to retract the contour wheels, decreasing the cut height.
- Pull toggle switch (C) toward you (direction [B]) to extend the contour wheels, increasing the cut height.

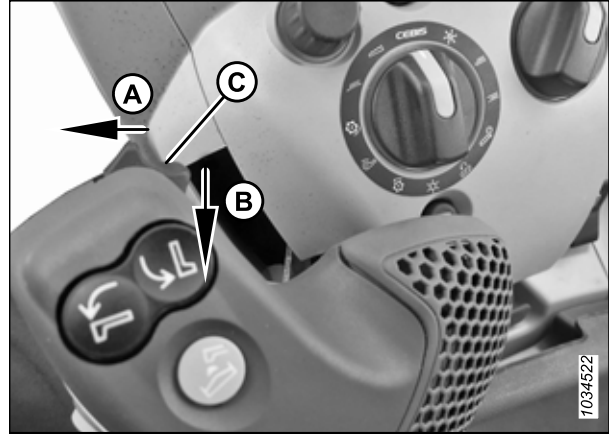


Figure 3.275: CMOTION Lever

5. **If the combine is equipped with the standard lever:**

- Pull toggle (C) down (direction [A]) to retract the contour wheels, decreasing the cut height.
- Push toggle (C) up (direction [B]) to extend the contour wheels, increasing the cut height.

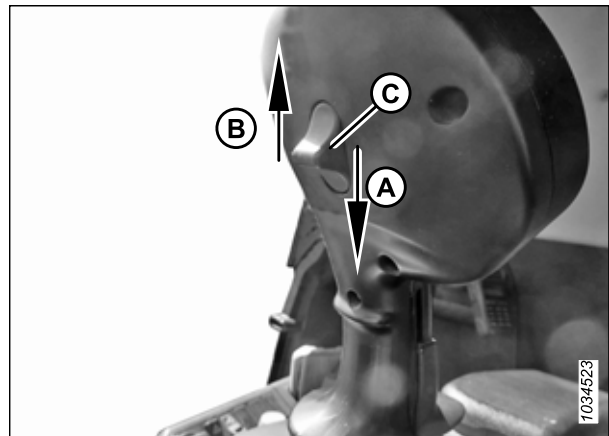


Figure 3.276: Standard Lever

### *Extending/Retracting Contour Wheels using Integrated Controls – CLAAS Lexion 8000 Series*

For the integrated pitch and contour wheel control to work, the OTHER HEADER FUNCTIONS must be selected on the combine's CEBIS terminal.

1. From the main page, select HEADER icon (A).

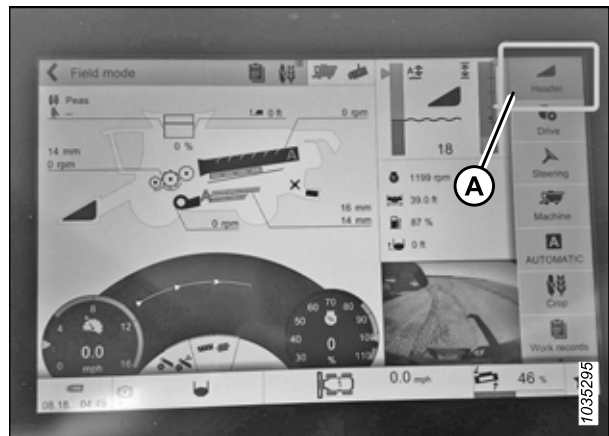


Figure 3.277: Header Function Icon

## OPERATION

2. Select OTHER HEADER FUNCTION icon (A).

**NOTE:**

This function can be added to the FAVORITES menu, and can be accessed quickly using the STAR button on the multifunction lever.

**NOTE:**

If the OTHER HEADER FUNCTION button does not appear, then the header ID will need to be configured in CEBIS. For instructions, refer to the combine operator's manual.

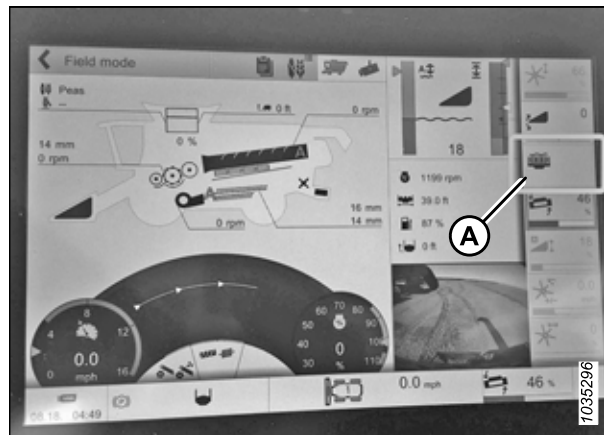


Figure 3.278: Other Header Function Icon

3. To access the functions saved to FAVORITES, press STAR button (A) on the multifunction lever.



Figure 3.279: Favorites Button

### Selecting Default Function for Multifunction Lever Toggle Switch

The default function for the combine's multifunction lever toggle switch is selectable. For example, when cutting on the ground, the default function can be set so that the toggle switch activates the pitch control cylinder. Similarly, when cutting above the ground, the default function can be changed so that the toggle switch controls the contour wheels.

**NOTE:**

The only indication of which default function is configured is by observing what header feature is activated when the toggle switch is operated.



### **DANGER**

Ensure that all bystanders have cleared the area.

## OPERATION

1. To select pitch control as the default toggle function, pull multifunction lever toggle switch (A) toward you while simultaneously pressing the reel fore button. Hold these switches for 30 seconds.
2. To select contour wheel as the default toggle function, pull multifunction lever toggle switch (A) toward you while simultaneously pressing the reel aft button. Hold these switches for 30 seconds.

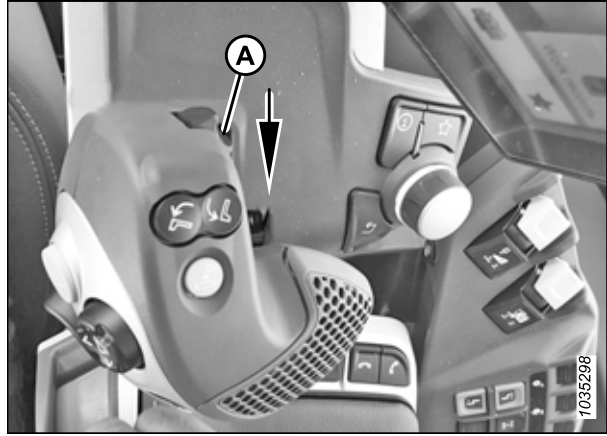


Figure 3.280: CMOTION Lever

### Extending and Retracting Contour Wheels – CLAAS Lexion 8000 Series

The CMOTION multifunction lever's toggle switch can be set so that it controls the position of the contour wheels on the header.

#### DANGER

Ensure that all bystanders have cleared the area.

#### *Controlling contour wheels when pitch control is set as default function*

1. On the CMOTION multifunction lever, pull toggle switch (A) toward you while simultaneously pressing the REEL FORE-AFT button.
  - The reel fore function will cause the contour wheels to retract, decreasing the cut height.
  - The reel aft function will cause the contour wheels to extend, increasing the cut height.

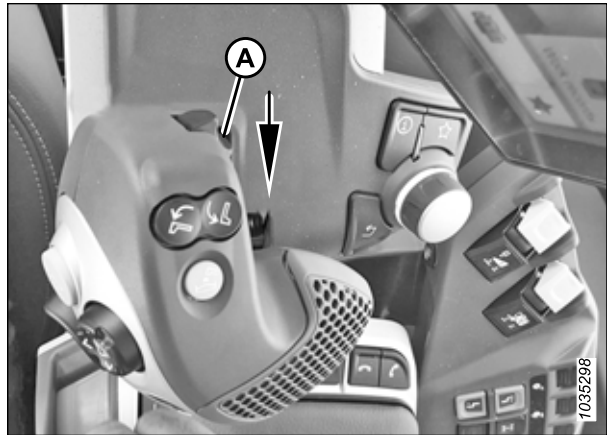


Figure 3.281: CMOTION Lever

## OPERATION

### *Adjusting contour wheels when contour wheel is selected as default function*

- Operate the CMOTION lever as follows:
  - Push toggle switch (C) away from you (direction [A]) to retract the contour wheels, decreasing the cut height.
  - Pull toggle switch (C) toward you (direction [B]) to extend the contour wheels, increasing the cut height.

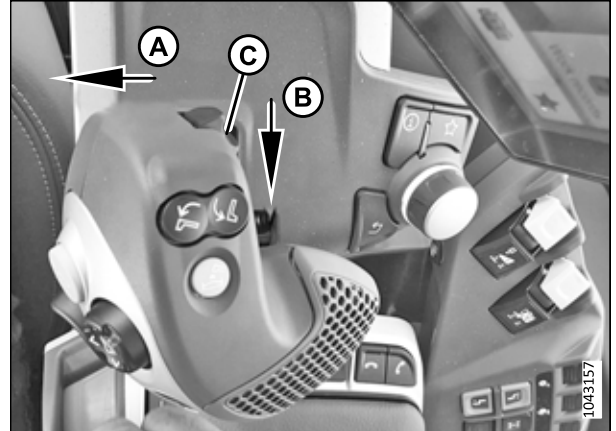


Figure 3.282: CMOTION Lever

### *Extending/Retracting Contour Wheels using Integrated Controls – John Deere X9 Series*

The height of the contour wheels can be adjusted using the CommandCenter™ display, ground speed lever, or console.

#### **⚠ DANGER**

Ensure that all bystanders have cleared the area.

#### **NOTE:**

Changes may have been made to the combine controls or the display since this document was published. For the most up-to-date information, refer to the combine operator's manual.

Operate the contour wheels using one of these methods:

- From the HEADER page of the CommandCenter™ display, select GAUGE WHEELS, then select the arrows to raise or lower the wheels. For instructions, proceed to Step 1, page 201.
- Assign ground speed lever (GSL) buttons “C” or “D” to GAUGE WHEEL HEIGHT. For instructions, proceed to Step 1, page 202.
- Assign console buttons “1” or “2” to GAUGE WHEEL HEIGHT. For instructions, proceed to Step 1, page 203.

#### **Method 1: Operating contour wheels using the HEADER page**

- Press HEADER button (A) on the panel below the display. The HEADER page opens.



Figure 3.283: CommandCenter™ Display

## OPERATION

2. Select GAUGE WHEELS (A).

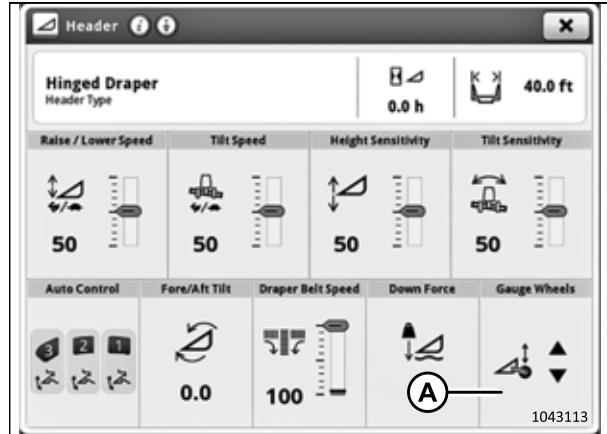


Figure 3.284: CommandCenter™ Display

3. Once the GAUGE WHEELS pop-up appears:

- To raise the wheels, press arrow (A).
- To lower the wheels, press arrow (B).

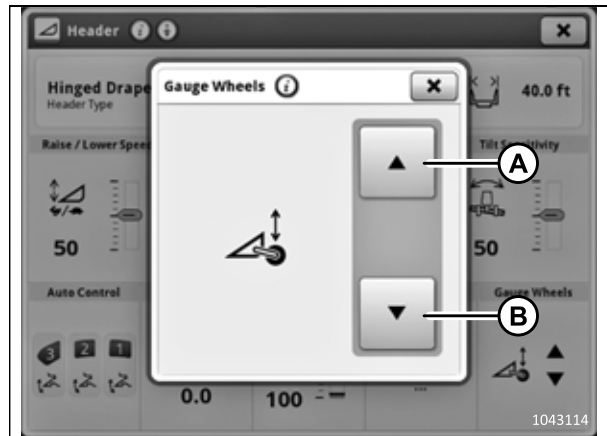


Figure 3.285: CommandCenter™ Display

### *Method 2: Operating contour wheels using the ground speed lever (GSL)*

1. Press multi-function lock button (A) until the light turns off. The CONTROLS SETUP page appears.



Figure 3.286: John Deere X9 Console



## OPERATION

2. On the CONTROLS SETUP page, select function button “C” or “D”.



Figure 3.287: John Deere X9 Display – Controls Setup

3. On the SELECT FUNCTION window, select GAUGE WHEEL HEIGHT (A).
4. The GSL button assigned GAUGE WHEEL HEIGHT can now be used to raise or lower the contour wheels.

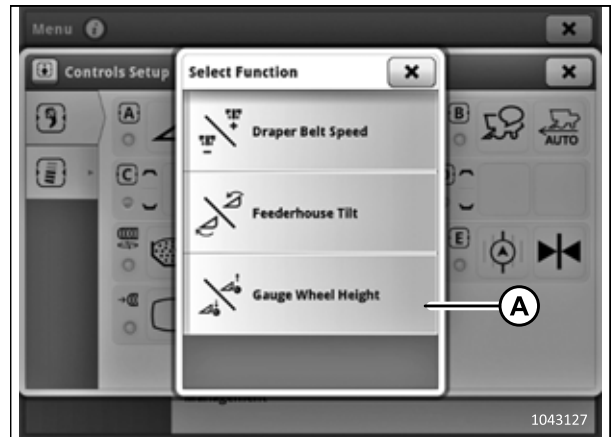


Figure 3.288: John Deere X9 Display – Controls Setup

### **Method 3: Operating contour wheels using the console**

1. Press console lock button (A) until the light turns off. The CONTROLS SETUP page appears.



Figure 3.289: John Deere X9 – Console

## OPERATION

- On the CONTROLS SETUP page, select console button “1” or “2”.

**NOTE:**

Only button 2 is a rocker switch.

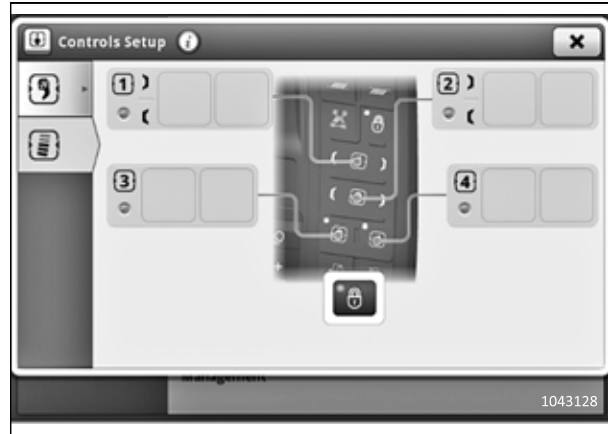


Figure 3.290: John Deere X9 Display – Controls Setup

- On SELECT FUNCTION window, select GAUGE WHEEL HEIGHT (A).
- The console button assigned GAUGE WHEEL HEIGHT can now be used to raise or lower the contour wheels.



Figure 3.291: John Deere X9 Display – Controls Setup

### Leveling Contour Wheel Height

The contour wheels allow the header to follow the contours of the ground, and can be adjusted between 25 mm (1 in.) and 457 mm (18 in.) from the ground surface.

#### **DANGER**

To prevent bodily injury or death from the unexpected start-up or fall of a raised machine, always stop the engine and remove the key before leaving the operator’s seat, and always engage the safety props before going under the machine for any reason.

#### **DANGER**

Ensure that all bystanders have cleared the area.

**NOTE:**

Set the header float before leveling the contour wheels. For instructions, refer to [Checking and Adjusting Header Float, page 210](#).

**NOTE:**

Set the wing balance before leveling the contour wheels. For instructions, refer to [3.9.4 Checking and Adjusting Wing Balance, page 226](#).



## OPERATION

1. Unlock the header wings. For instructions, refer to *Operating in Flex Mode, page 221*.
2. Unlock the header float. For instructions, refer to *Locking / Unlocking Header Float, page 221*.
3. Park the combine on a level surface.
4. Lower the reel fully.
5. Adjust the contour wheels so that height indicator (A) is at number 2 (B).

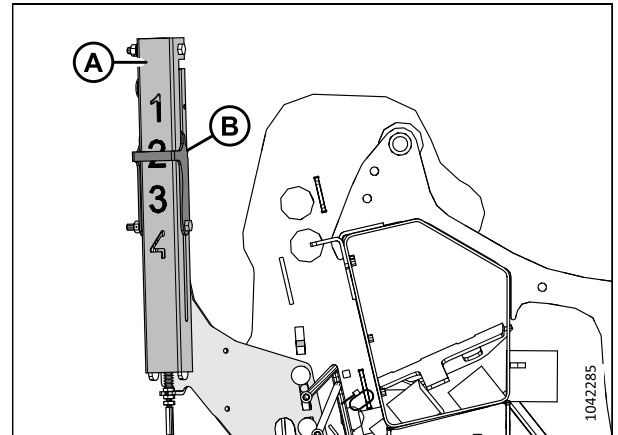


Figure 3.292: Height Indicator – Rear Left End

6. Lower the header until auto header height indicator arm (A) is at number 2 (B).
7. Shut down the engine, and remove the key from the ignition.

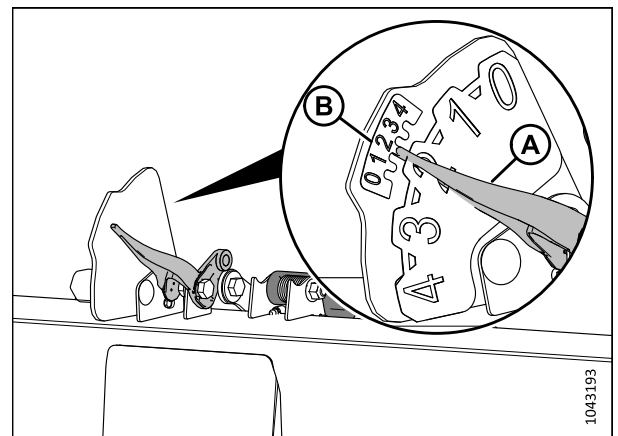


Figure 3.293: Auto Header Height Indicator

## OPERATION

8. At the center of the header, measure distance (A) from the ground to the tip of the center guard. Record distance (A).
9. At each end of the header, measure distance (A) from the ground to the tip of the end guard. Record both of the measurements.
  - If the difference between the center measurement and the end measurements is less than 25 mm (1 in.), no adjustment is required.
  - If the difference between the center measurement and the end measurements is greater than 25 mm (1 in.), adjustment is required. Continue to the next step.
10. Start the engine.
11. Raise the header fully.
12. Shut down the engine, and remove the key from the ignition.
13. Engage the header safety props. For instructions, refer to the combine operator's manual.

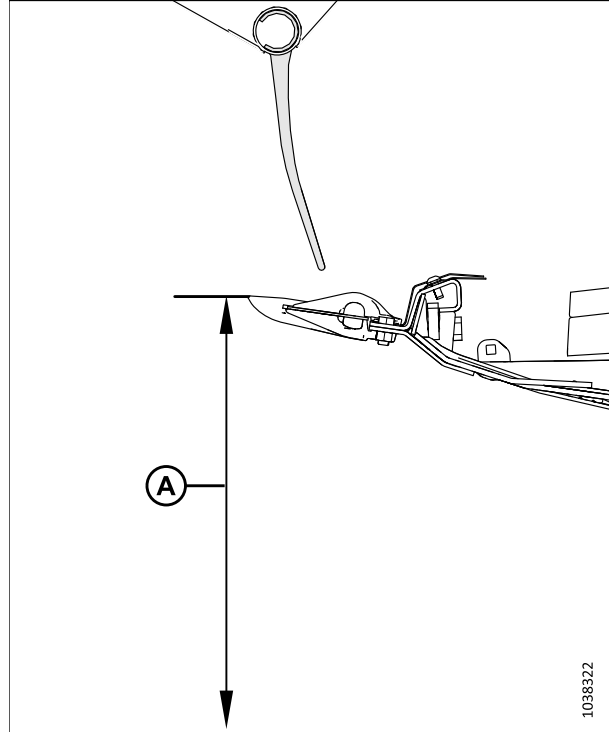


Figure 3.294: Float Setting Indicator

14. Remove pin (A).
15. Reposition adjuster plate (B) in the slot to align with a different hole. There is approximately a 24 mm (1/2 in.) difference between each of the holes.
  - If the measurement is less than the measurement at the center of the header, move the adjuster plate **TOWARD** the cutterbar.
  - If the measurement is more than the measurement at the center of the header, move the adjuster plate **AWAY** from the cutterbar.
16. Reinstall pin (A).
17. On the opposite end of the header, repeat Step 14, [page 206](#) and Step 16, [page 206](#).

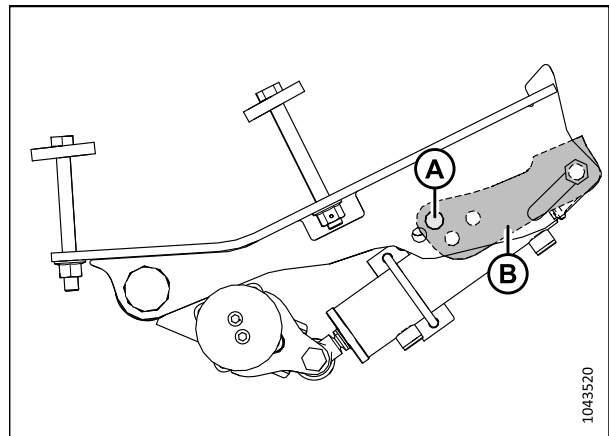


Figure 3.295: Pin Location – Left Outer Wheel

## OPERATION

18. Disengage the header safety props. Refer to the combine operator's manual for instructions.
19. Lower the header until auto header height indicator arm (A) is at number 2 (B).
20. Shut down the engine, and remove the key from the ignition.
21. Measure the guard to ground distance again. Ensure that the three measurements are the same. If more adjustment is required, repeat Steps [14, page 206](#) to [17, page 206](#).

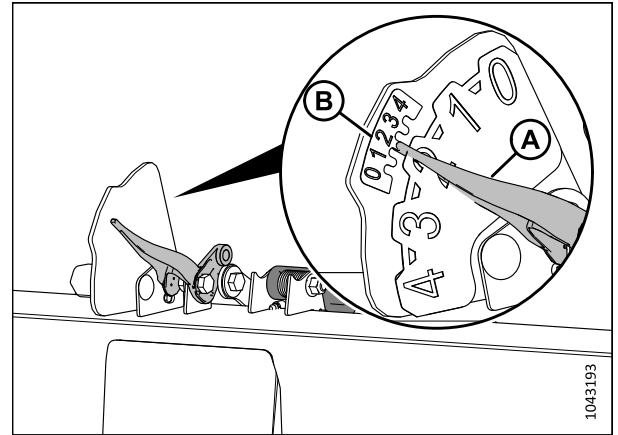


Figure 3.296: Auto Header Height Indicator

### 3.9.2 Cutting on Ground

Cutting height will vary depending on crop type, crop conditions, cutting conditions, etc.

Cutting on the ground is performed with the header fully lowered and the cutterbar on the ground. The orientation of the knife and the knife guards relative to the ground (the header angle) is controlled by the skid shoes and the center-link—it is **NOT** controlled by the header lift cylinders. The skid shoes, center-link, and flex lockout allow you to adjust to the field conditions and maximize the amount of material cut while reducing damage to the knife caused by stones and debris.

The flexible cutterbar, the wings, and the header float system compensate for ridges, trenches, and other variations in the ground contour to prevent the cutterbar from pushing into the ground or leaving any uncut crop.

Refer to the following topics for additional information:

- [Adjusting Inner Skid Shoes, page 207](#)
- [Adjusting Outer Skid Shoes, page 208](#)
- [3.9.3 Header Float, page 209](#)
- [3.9.5 Header Angle, page 232](#)

#### *Adjusting Inner Skid Shoes*

The skid shoes and the center-link allow you to adjust to the field conditions and maximize the amount of material cut while reducing damage to the knife caused by stones and debris.

#### **DANGER**

To prevent bodily injury or death from the unexpected start-up or fall of a raised machine, always stop the engine, remove the key, and engage the safety props before going under the header for any reason.

#### **DANGER**

Ensure that all bystanders have cleared the area.

#### **IMPORTANT:**

Running the skid shoes in the down position can speed up wear on the skid shoe plates.

## OPERATION

1. Raise the header fully.
2. Shut down the engine, and remove the key from the ignition.
3. Engage the header safety props. For instructions, refer to the combine operator's manual.
4. Raise the stabilizer wheels or the transport wheels fully (if installed). For instructions, refer to the following:
  - [Adjusting Stabilizer Wheels, page 190](#)
  - [Adjusting EasyMove™ Transport Wheels, page 191](#)
5. Remove lynch pin (A) from each skid shoe.
6. Hold shoe (B) and remove pin (C) by disengaging from the frame and pulling away from the shoe.
7. Raise or lower skid shoe (B) to achieve the desired position using the holes in support (D) as a guide.
8. Install pin (C) in the desired position on support (D), engage in frame, and secure with lynch pin (A).
9. Ensure that both of the skid shoes are adjusted to the same position.
10. Adjust the header angle to the desired working position using the machine's header angle controls.

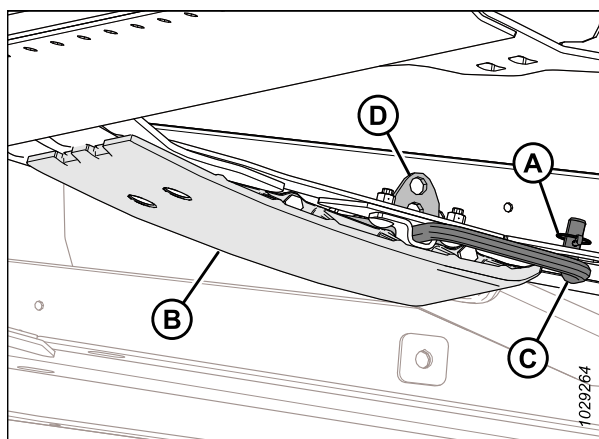


Figure 3.297: Inner Skid Shoe

### NOTE:

If the header angle is not critical, set it to the mid-position.

11. Check the header float. For instructions, refer to [3.9.3 Header Float, page 209](#).

### Adjusting Outer Skid Shoes

The skid shoes and the center-link allow you to adjust to the field conditions and maximize the amount of material cut while reducing damage to the knife caused by stones and debris.

### DANGER

To prevent bodily injury or death from the unexpected start-up or fall of a raised machine, always stop the engine, remove the key, and engage the safety props before going under the header for any reason.

### DANGER

Ensure that all bystanders have cleared the area.

### IMPORTANT:

Running the skid shoes in the down position can speed up wear of the skid shoes.

1. Raise the header fully.
2. Shut down the engine, and remove the key from the ignition.
3. Engage the header safety props. For instructions, refer to the combine operator's manual.

## OPERATION

4. Raise the stabilizer wheels or the transport wheels fully (if installed). For instructions, refer to the following:
  - [Adjusting Stabilizer Wheels, page 190](#)
  - [Adjusting EasyMove™ Transport Wheels, page 191](#)
5. Remove lynch pin (A) from each skid shoe pin (C).
6. Hold skid shoe (B) and remove pin (C) by disengaging it from the bracket and pulling it away from the shoe.
7. Raise or lower skid shoe (B) to achieve the desired position using the holes in the support plate as a guide.
8. Reinstall pin (C) in the desired position on the support plate, engage the pin into the bracket, and secure it with lynch pin (A).
9. Ensure that all of the skid shoes are adjusted to the same position.
10. Check the header float. For instructions, refer to [3.9.3 Header Float, page 209](#).

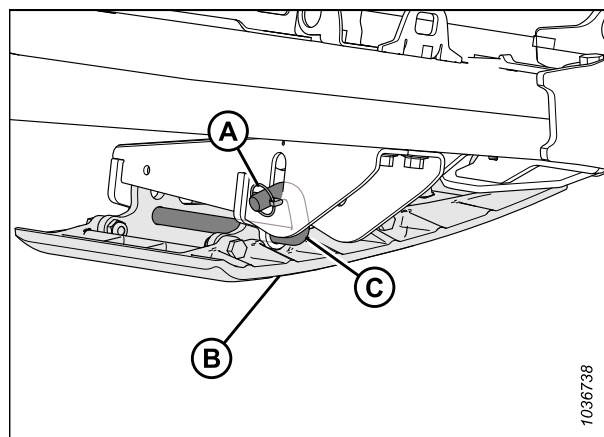


Figure 3.298: Outer Skid Shoe

### 3.9.3 Header Float

The header float system supports the weight of the header to reduce the pressure of the ground on the cutterbar, allowing the header to more easily follow the ground and quickly respond to sudden changes or obstacles.

The header float is indicated by float indicator (A). Values 0 to 4 represent the pressure of the cutterbar on the ground, with 0 being the minimum, and 4 being the maximum. These values also represent where the header is at in the float range, with 0 being the bottom end of the float range, and 4 being the top end of the float range.

#### IMPORTANT:

The indicator on the left side of the float module is for float indication and float settings; the indicator on the right side is for float settings only.

The maximum force is determined by the tension on the float module's adjustable float springs. The float can be changed to suit different conditions and it is dependent on what options have been installed on the header.

#### NOTE:

Decal (B) at the top of the float indicator is used to check and adjust the float setting. For instructions, refer to [Checking and Adjusting Header Float, page 210](#).

The FD2 Series FlexDraper® Header performs best with minimum ground pressure under normal conditions. If you are adding optional attachments to the header that will affect its weight, readjust the float.

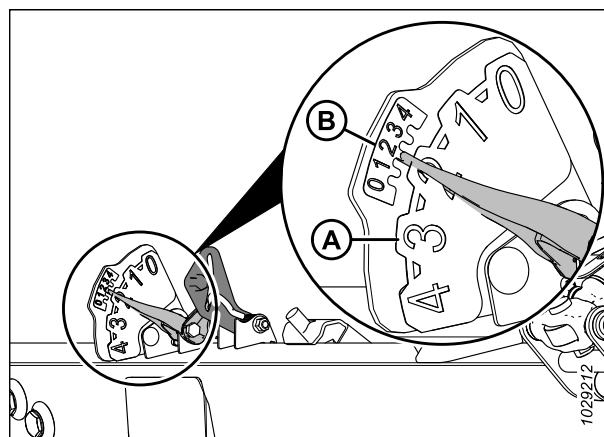


Figure 3.299: Float Indicator – Left Side

## OPERATION

1. Set the float for cutting on the ground as follows:
  - a. Ensure that the header float locks are disengaged. For instructions, refer to [Locking / Unlocking Header Float, page 221](#).
  - b. Using the combine header controls, lower the feeder house until float indicator (A) reaches the desired float value (cutterbar ground force). Set the float indicator initially to float value 2 and adjust the float as necessary.
2. Set the float for cutting off the ground as follows:
  - a. Adjust the wheels. For instructions, refer to [3.9.1 Cutting off Ground, page 189](#).
  - b. Note the float value on the float indicator and maintain this value during operation (disregard minor fluctuations on the indicator).

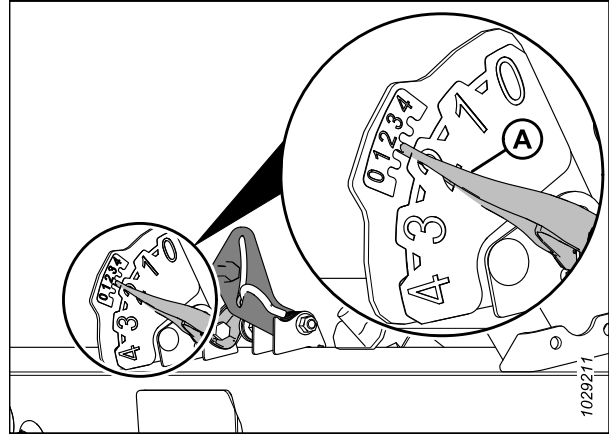


Figure 3.300: Cutting on the Ground

### Checking and Adjusting Header Float

The header is equipped with a suspension system that floats the header over the ground to compensate for changes in ground elevation. If the header float is not set properly, the cutterbar may scoop soil or it may leave crop uncut. If the float setting is not satisfactory, it will need to be inspected and adjusted.

#### IMPORTANT:

Do **NOT** use the float module springs to level the header.

When adjusting the float, use the following guidelines:

- Set the header float as light as possible, but not so light that the header bounces when the combine is moving. This will help prevent knife breakage, soil pushing, soil build-up at the cutterbar in wet conditions, and excessive wear to the skid shoes and cutterbar wearplates.
- To prevent the header from bouncing excessively and cutting unevenly when the float is light, operate the combine at a lower ground speed.
- To cut crop while the header is above ground level, use the stabilizer wheels in conjunction with the header float. This will minimize bouncing at the header ends and help regulate the cut height. For instructions, refer to [Adjusting Stabilizer Wheels, page 190](#).

#### DANGER

Ensure that all bystanders have cleared the area.

#### DANGER

To prevent injury or death from the unexpected start-up of the machine, always stop the engine and remove the key from the ignition before leaving the operator's seat for any reason.

#### NOTE:

If you cannot achieve an adequate header float after using all of the available adjustments, change the float spring configuration. For instructions, refer to [Changing Float Spring Configuration and Installation Location – Float Levers with Two Holes, page 216](#).

## OPERATION

To check and adjust the float settings, do the following:

### Preliminary steps

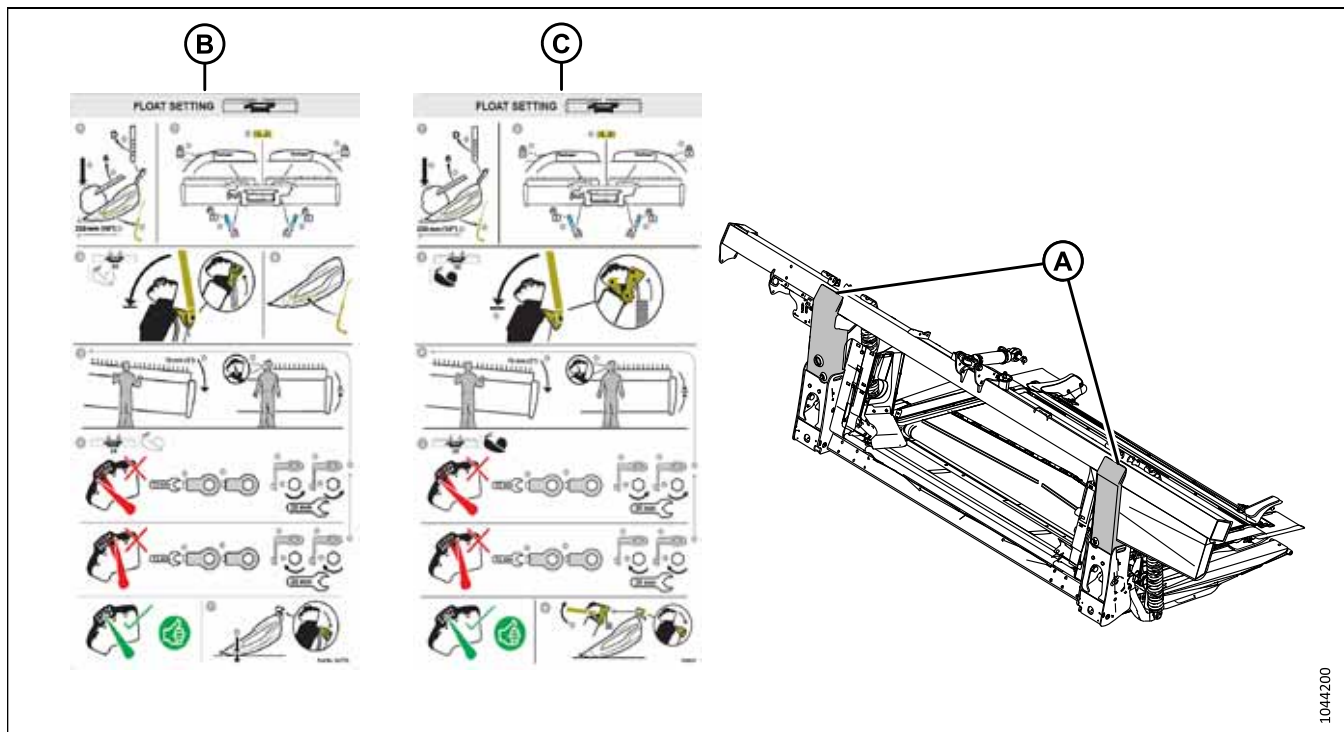


Figure 3.301: Decal Locations – Model Year 2023 and Earlier (B) and Model Year 2024 (C)

#### NOTE:

This procedure is summarized on decal (B) (MD #360716) for model year 2023 and earlier, and decal (C) (MD #368631) for model year 2024, on locations (A).

1. Park the combine on a level surface.
2. Ensure that the header is level with the ground. If adjustment is required:
  - Ensure that the combine is parked on a level surface.
  - If equipped, use the combine's lateral tilt to level the feeder house with the ground.
  - If further adjustment is required, shut the engine off, remove the key from the ignition, and ensure that the combine's tires are inflated to the correct pressure.

#### NOTE:

Spirit level (A) is located on top of the float module frame. The header is level if the bubble is in the center of the spirit level.

3. Position the header so that the cutterbar is 254–356 mm (10–14 in.) off the ground.

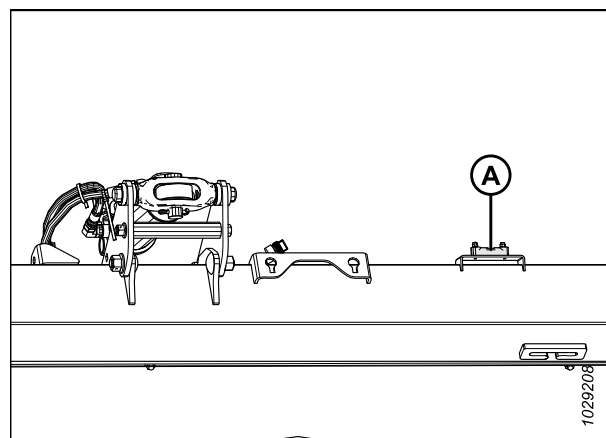


Figure 3.302: Spirit Level

## OPERATION

- Adjust the reel fore-aft position so that the indicator on left indicator bracket (A) is at position 6.

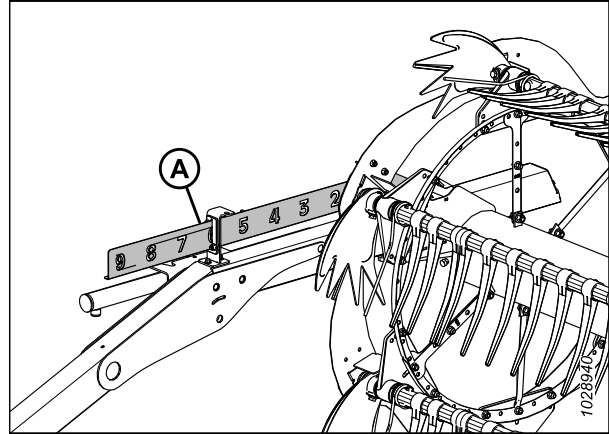


Figure 3.303: Fore-Aft Position

- Adjust center-link (A) so that indicator (B) is at position D on the gauge.
- Lower the reel fully.
- Shut down the engine, and remove the key from the ignition.
- Lock the header wings. For instructions, refer to [Operating in Rigid Mode, page 224](#).
- If transport wheels are installed on the header, move them to the uppermost position.

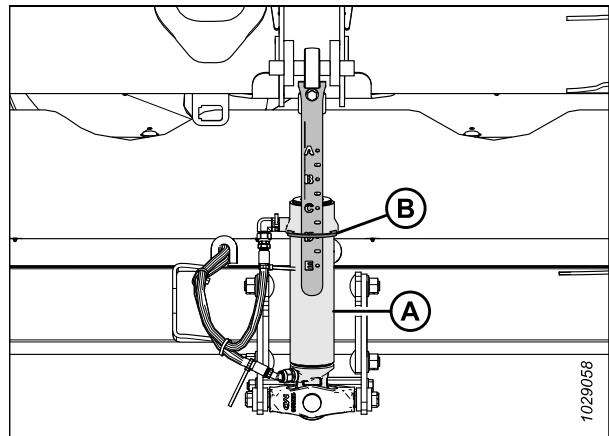


Figure 3.304: Center-Link

- If the pointer is not on zero, loosen bolt (A) and rotate float indicator plate (B) until pointer (C) is on 0 (D). Tighten the nut on bolt (A).

**NOTE:**

Use zero dot (E) above the decal to correctly set the indicator needle.

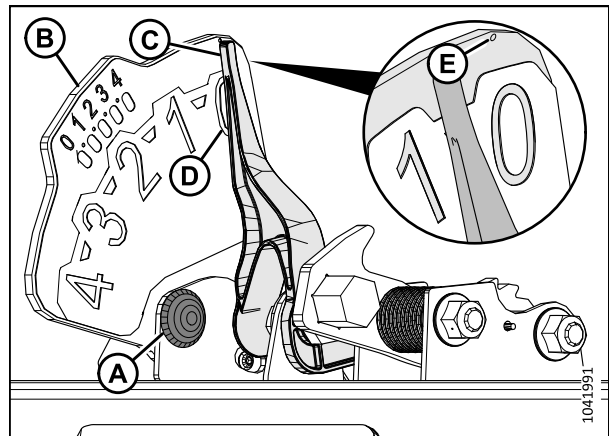


Figure 3.305: Float Indicator



## OPERATION

11. Disengage both of the header float locks by pulling float lock handle (A) away from the float module and push the float lock handle down and into position (B) (UNLOCK).

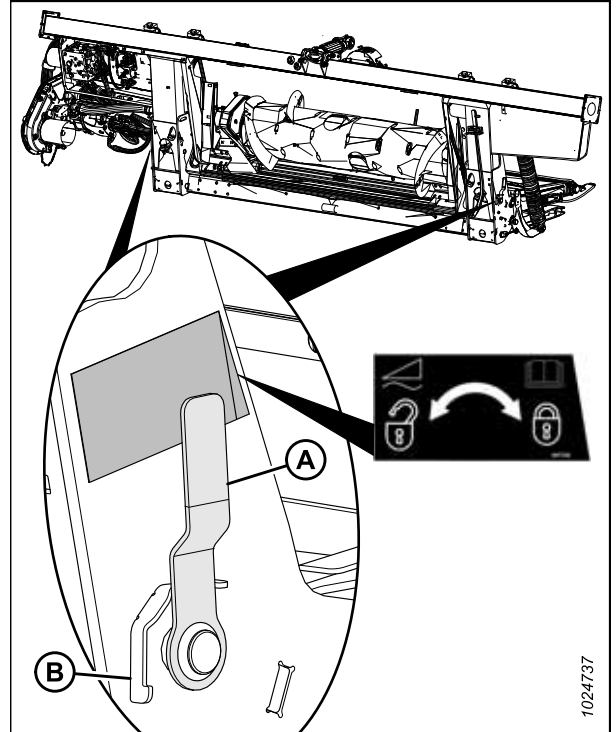


Figure 3.306: Header Float Lock in Locked Position

12. Open the left endshield. For instructions, refer to [Opening Header Endshields](#), page 41.
13. Remove hairpin (A) securing multi-tool (B) to the bracket on the left endsheet.
14. Remove multi-tool (B). Replace the hairpin.

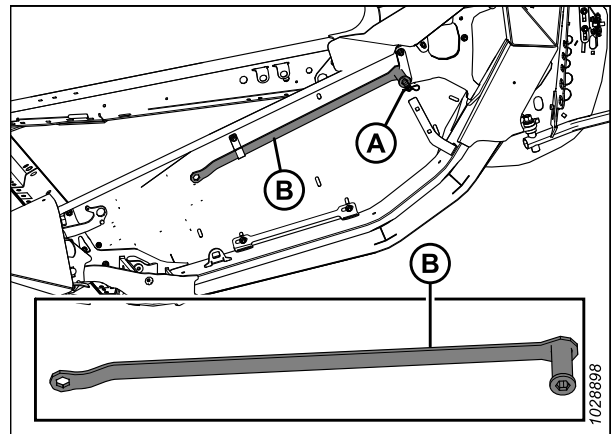


Figure 3.307: Multi-Tool Location

## OPERATION

### Setting the float setting levers

15. On the left side of the float module, lift float setting lever (A) by hand so that the lever is free of slack.

**NOTE:**

Some parts have been removed from the illustration for clarity.

16. Fully engage the flat end of multi-tool (B) onto the float setting lever. The multi-tool should be angled toward the front of the float module.
17. Pull multi-tool (B) toward the back of the float module until float setting lever (A) cannot be pulled back any further and it is locked into place on last tooth (C) of the lever.
18. Repeat Steps 16, page 214 to 18, page 214 to set the right float setting lever.

**IMPORTANT:**

Set both the left and the right float setting levers **BEFORE** adjusting the float on either side of the header.

19. Remove the multi-tool and set it aside.

### Checking the float

20. Set the left float by pushing the left end of the header down by approximately 76 mm (3 in.). Allow the header to rise. Repeat this step at least three times.

**NOTE:**

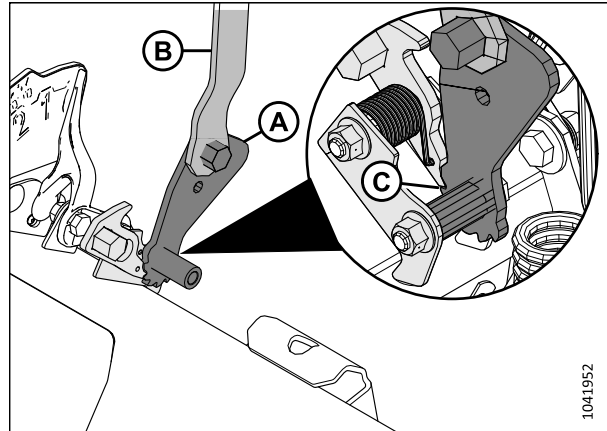
Moving the left side of the header up and down ensures that the reading on the left indicator will be accurate.

21. On the left side of the float module, inspect upper scale on float setting indicator (FSI) (B). Arm (A) on the indicator should point to the number 2.

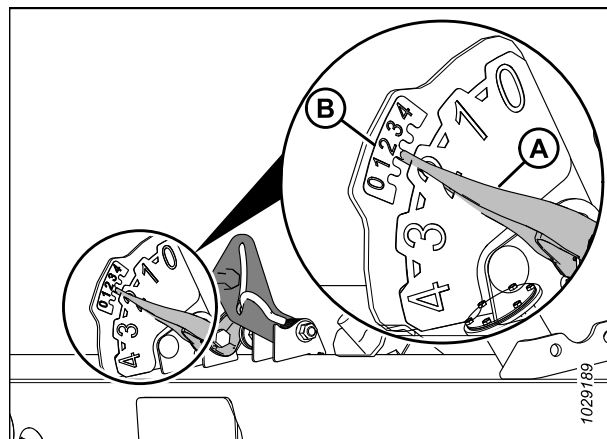
- If arm (A) on indicator (B) points to a value higher than 2, then the float is too heavy.
- If arm (A) on indicator (B) points to a value lower than 2, then the float is too light.

**NOTE:**

The lower set of numbers indicates the float height while the header is operating in the field.



**Figure 3.308: Multi-Tool Engaged with Left Float Setting Assembly**



**Figure 3.309: Left Float Setting and AHHC Indicator**

**Adjusting the float**

22. On the left side of the float module, loosen bolts (C). Rotate spring locks (B) so that bolt heads (A) are accessible.
23. Increase or decrease the float on the left side of the float module as needed:
  - To make the header lighter (to increase the float), turn adjustment bolts (A) clockwise.
  - To make the header heavier (to decrease the float), turn adjustment bolts (A) counterclockwise.

**NOTE:**

Adjust each pair of bolts (A) by the same amount.

24. Set the left float again. Refer to Step 21, page 214 for instructions.
25. Check the left float setting indicator again. Refer to Step 22, page 214 for instructions.
26. If the left float setting is not satisfactory, repeat Step 24, page 215 to Step 26, page 215.
27. Check and adjust the right float. For instructions, refer to Step 21, page 214 to Step 27, page 215.

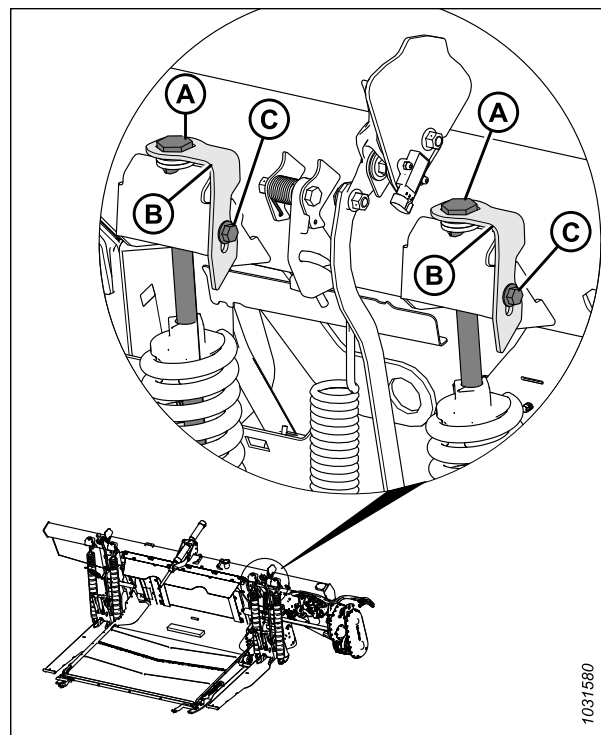


Figure 3.310: Left Float Adjustment

**CAUTION**

To prevent cuts, pinches, and other bodily harm to the person checking the down stops, ensure that nobody is manually lifting, bouncing, or moving the header in any way while the down stop washer is being touched and checked for movement.

28. Ensure that the float lock linkage is on the down stops (washer [A] cannot move) at both locations.

**NOTE:**

If the header is **NOT** on the down stops, the voltage may go out of range during operation and cause the AHHC system to malfunction. To fix the problem, make the header heavier by decreasing the float. For instructions, return to Step 24, page 215.

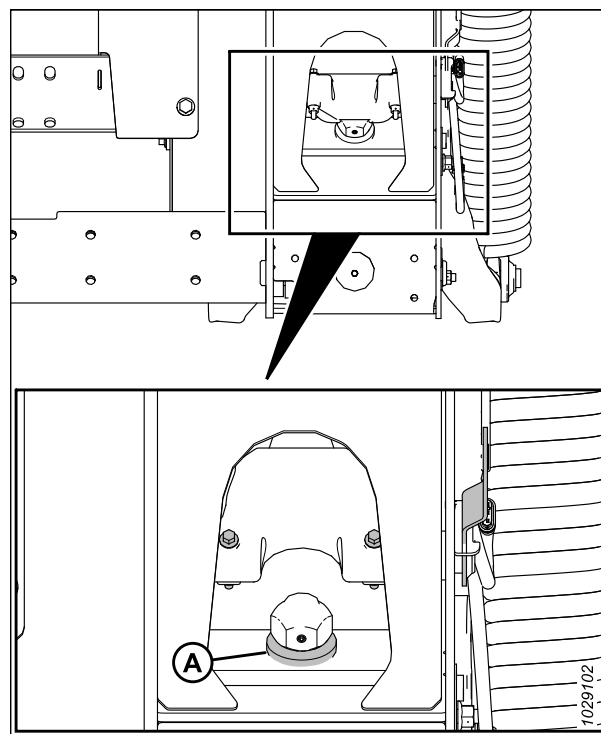


Figure 3.311: Down Stop Washer

## OPERATION

29. On both sides of the float module, lock adjustment bolts (A) with spring locks (B). Ensure that bolt heads (A) are engaged in the spring lock cutouts. Tighten bolts (C) to secure the spring locks.

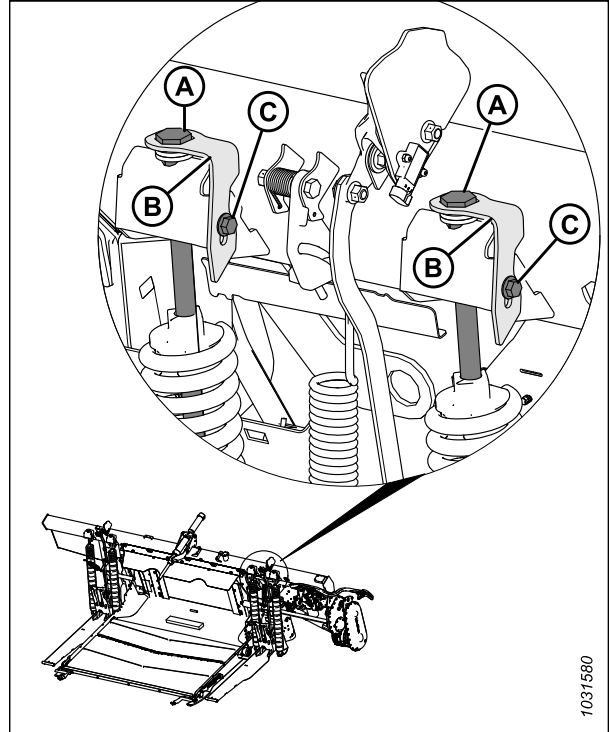


Figure 3.312: Left Float Adjustment

### Releasing the float setting levers

#### WARNING

Release the float setting lever before resuming operation.

30. Fully engage multi-tool (C) onto pawl (B) and push it upward to release float setting lever (A).
31. Adjust the wing balance. For instructions, proceed to [3.9.4 Checking and Adjusting Wing Balance, page 226](#).

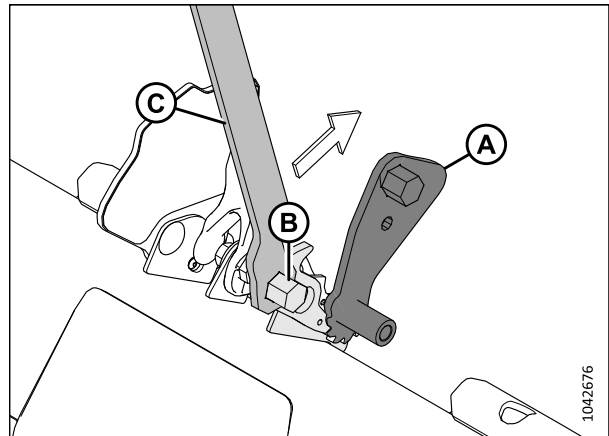


Figure 3.313: Multi-Tool Engaged with Left Pawl

### Changing Float Spring Configuration and Installation Location – Float Levers with Two Holes

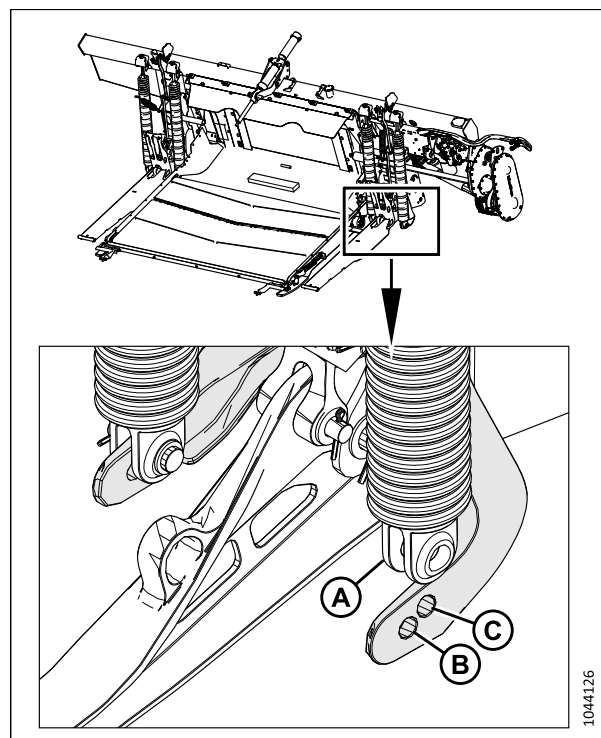
The header's float spring configuration and location is determined by the weight of the header.

#### DANGER

To prevent injury or death from the unexpected start-up of the machine, always stop the engine and remove the key from the ignition before leaving the operator's seat for any reason.

## OPERATION

If the weight of the header has changed (for example, due to the addition of optional equipment), the float spring configuration (A) (single spring or double spring) or location [float lever front hole (B) or back hole (C)] may need to be changed. To determine the appropriate float spring configuration and installation location, the weight of the header and optional equipment must be calculated. For instructions, proceed to Step 1, [page 217](#).



**Figure 3.314: Float Spring Detached from Float Lever**

### ***Determining header weight, spring configuration, and spring installation location***

1. Referring to [Table 3.18, page 217](#), calculate the total weight of the header according to the formula  $(A) + (B) + (C) + (D) = \text{Total header weight}$ , where:
  - Base header weight is (A)
  - Weight of dividers, if any, is (B)
  - Weight of upper cross auger (UCA), if installed, is (C)
  - Weight of other options, if any, is (D)

For an example of this calculation, refer to [Example, page 218](#).

**Table 3.18 Header Component Weights**

Category	Header Model	Knife Configuration	Reel Configuration	Weight
(A) Base header weight – select one	FD225	Single	Any	N/A. Use the back hole on the float lever.
	FD230	Single	Any	2400 kg (5300 lb.)
	FD235	Single	Any	2600 kg (5750 lb.)
	FD235	Double	Any	2700 kg (5950 lb.)
	FD240	Single	Any	2800 kg (6150 lb.)
	FD240	Double	Any	N/A. Use the front hole on the float lever.
	FD241	Double	Any	N/A. Use the front hole on the float lever.

## OPERATION

**Table 3.18 Header Component Weights (continued)**

Category	Header Model	Knife Configuration	Reel Configuration	Weight
	FD245	Double	Any	3225 kg (7100 lb.)
	FD250	Double	Any	3400 kg (7500 lb.)
(B) Dividers – select up to one option	<b>Divider Option Installed</b>			
	Rice divider rods			20 kg (50 lb.)
	Vertical knives			185 kg (407 lb.) <sup>57</sup>
(C) Upper cross auger (UCA) – if a UCA is installed on the header, select one option <sup>58</sup>	<b>UCA Option Installed</b>			
	FD230 two piece			142 kg (312 lb.)
	FD235 two piece			156 kg (343 lb.)
	FD240 three piece			168 kg (370 lb.)
	FD245 three piece			191 kg (420 lb.)
	FD250 three piece			212 kg (468 lb.)
(D) Other options – add any installed options	<b>Option Installed</b>			
	Transport wheels			360 kg (800 lb.)
	Contour wheels			205 kg (450 lb.)
	Stabilizer wheels			160 kg (350 lb.)

### Example

**Example of header weight calculation for FD235 FlexDraper® Header, single knife, double reel, no UCA, no options:**

Base header weight (A) = 2600 kg (5750 lb.)

Weight of vertical knives (B) = (70 kg (150 lb.))

Weight of UCA (C) = 0 kg (0 lb.)

Weight of options (D) = 0 kg (0 lb.)

Total header weight = (A) + (B) + (C) + (D) = 2670 kg (5900 lb.)

- Using the total header weight calculated in the previous step, refer to [3.19, page 219](#) to determine which weight range the header is in and which float spring configuration is best for the header.

#### NOTE:

Generally, heavier headers will need the float springs placed in the front float lever hole and lighter headers will use the back hole. Some headers will only have one possible float spring configuration.

57. Weight includes hydraulic package for FD250.

58. Add 24.5 kg (54 lb.) for hydraulic plumbing, if this was installed separately.

**OPERATION**

**Table 3.19 Float Spring Installation Location in Float Lever**

Header Model	Weight Range (Light)	Float Lever Hole	Weight Range (Heavy)	Float Lever Hole	Spring Configuration See Table 3.20, page 219
<b>Knife Configuration: Single</b>					
<b>Reel Configuration: Any</b>					
FD225	Use the back hole on the float lever				1
FD230	2400–2675 kg (5300–5900 lb.)	Back	2676–3215 kg (5901–7100 lb.)	Front	1
FD235	2600–3050 kg (5750–6700 lb.)	Back	3051–3415 kg (6701–7550 lb.)	Front	3
<b>Knife Configuration: Single</b>					
<b>Reel Configuration: Double</b>					
FD240	2800–3200 kg (6150–7000 lb.)	Back	3201–3615 kg (7001–7950 lb.)	Front	3
<b>Knife Configuration: Single</b>					
<b>Reel Configuration: Triple</b>					
FD240	2900–3400 kg (6393–7496 lb.)	Back	3401–3700 kg (7497–8157 lb.)	Front	4
<b>Knife Configuration: Double</b>					
<b>Reel Configuration: Any</b>					
FD235	2700–3150 kg (5950–6900 lb.)	Back	3151–3515 kg (6901–7750 lb.)	Front	2
FD241	Use the back hole on the float lever				4
FD245	3225–3475 kg (7100–7650 lb.)	Back	3476–4050 kg (7651–8900 lb.)	Front	4
FD250	3400–3800 kg (7500–8350 lb.)	Back	3801–4215 kg (8351–9300 lb.)	Front	5
<b>Knife Configuration: Double</b>					
<b>Reel Configuration: Double</b>					
FD240	2900–3400 kg (6,393–7,496 lb.)	Back	3401–3700 kg (7497–8157 lb.)	Front	4
<b>Knife Configuration: Double</b>					
<b>Reel Configuration: Triple</b>					
FD240	3000–3400 kg (6614–7496 lb.)	Back	3401–3800 kg (7497–8378 lb.)	Front	4

**Table 3.20 Float Springs Configuration**

Float Springs Configuration				
Configuration "S" = Single Spring (MD #308878) "D" = Double Spring (MD #308879)	Outer Left Side	Inner Left Side	Inner Right Side	Outer Right Side
1 – SSSS	Single	Single	Single	Single
2 – SSSD	Single	Single	Single	Double
3 – DSSS	Double	Single	Single	Single

OPERATION

Table 3.20 Float Springs Configuration (continued)

Float Springs Configuration				
Configuration "S" = Single Spring (MD #308878) "D" = Double Spring (MD #308879)	Outer Left Side	Inner Left Side	Inner Right Side	Outer Right Side
4 – DSSD	Double	Single	Single	Double
5 – DSDD	Double	Single	Double	Double

3. If the float springs need to be moved to a different float lever hole, or if a float spring needs to be changed, contact your Dealer.



### Locking / Unlocking Header Float

Two header float locks—one on each side of the float module—lock and unlock the header float system.

#### DANGER

To prevent bodily injury or death from the unexpected start-up of the machine, always stop the engine and remove the key from the ignition before making adjustments to the machine.

#### IMPORTANT:

Engage the float locks when transporting the header with the float module attached so that there is no relative movement between the float module and the header. The float locks must also be locked when detaching the float module from the combine to enable the feeder house to release the float module.

1. Shut down the engine, and remove the key from the ignition.
  - To disengage (unlock) the float locks, pull float lock handle (A) into position (B). In this position, the header is unlocked, and can float with respect to the float module.
  - To engage (lock) the float locks, push float lock handle (A) into position (C). In this position, the header cannot move with respect to the float module.

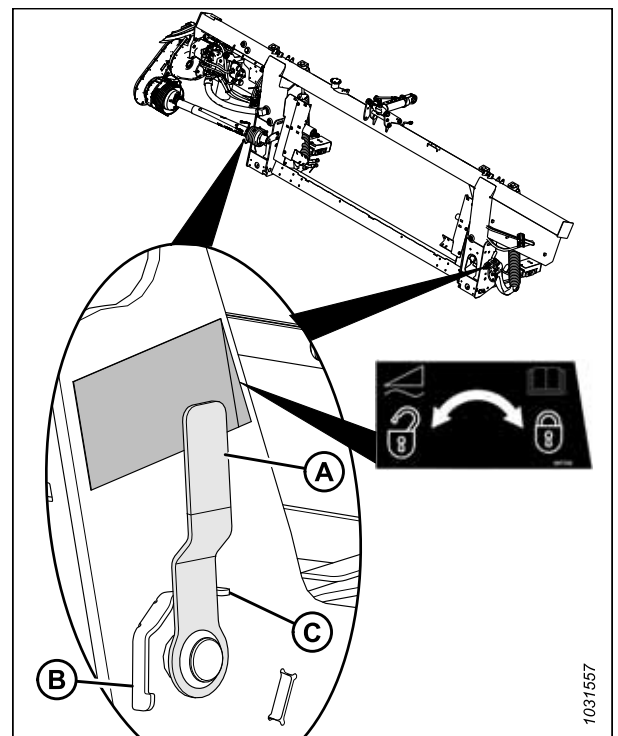


Figure 3.315: Float Lock – in Locked Position

### Operating in Flex Mode

The header is designed to operate with the cutterbar on the ground. The three sections of the cutterbar move independently to follow the ground contours. When the wings are unlocked, they are free to move up and down.

#### DANGER

To prevent bodily injury or death from the unexpected start-up of the machine, always stop the engine and remove the key from the ignition before making adjustments to the machine.

1. Shut down the engine, and remove the key from the ignition.

## OPERATION

2. Move spring handle (A) in the lower slot to unlock the wing. You should hear the lock disengage.
3. If the lock link does not disengage, move the wing by raising and lowering the header, changing the header angle, or driving the combine until it disengages.
4. If the lock still does not disengage, proceed to the next step.
5. Open the left endshield. For instructions, refer to [Opening Header Endshields, page 41](#).

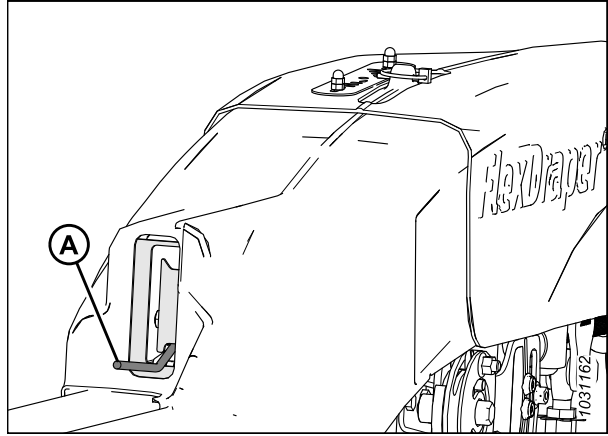


Figure 3.316: Wing in Unlocked Position

6. Remove hairpin (A) securing the multi-tool to the bracket on the left endsheet.
7. Remove multi-tool (B). Reinstall the hairpin onto the bracket.

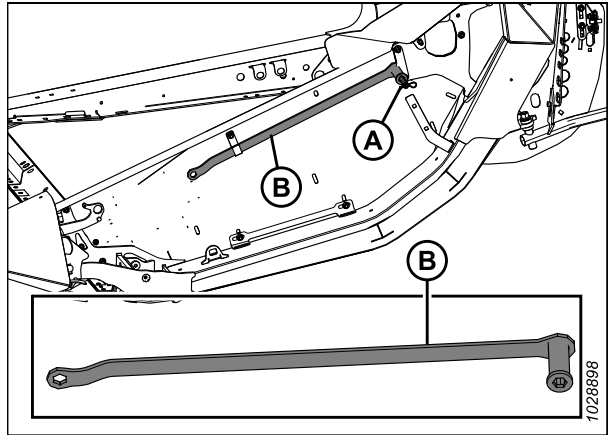


Figure 3.317: Left Endsheet

8. Attach flex checker cable (A) to flex checker cable lock (B).

**NOTE:**

The parts in the illustration have been removed for clarity.

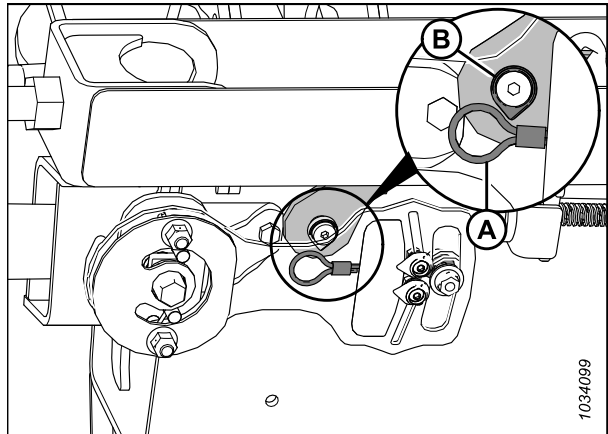


Figure 3.318: Flex Checker Cable Lock – Left Side

## OPERATION

9. Use multi-tool (A) on plate (B) to move the wing up and down until the lock disengages.

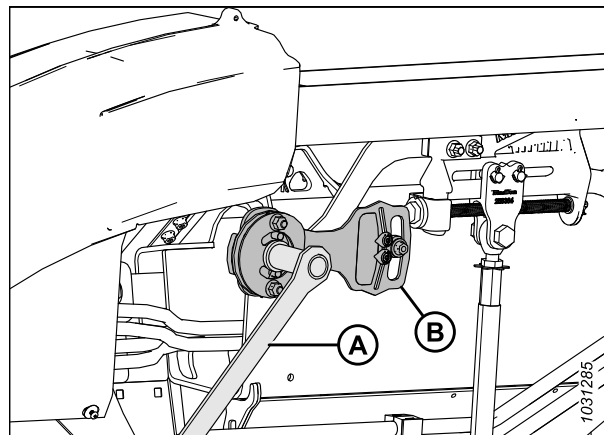


Figure 3.319: Wing Lock in Unlocked Position

10. Detach flex checker cable (A) from flex checker cable lock (B).

**NOTE:**

The parts in the illustration have been removed for clarity.

11. Return multi-tool (A) to its storage position. Reinstall the linkage cover.
12. If necessary, balance the wing. For instructions, refer to [3.9.4 Checking and Adjusting Wing Balance, page 226](#).

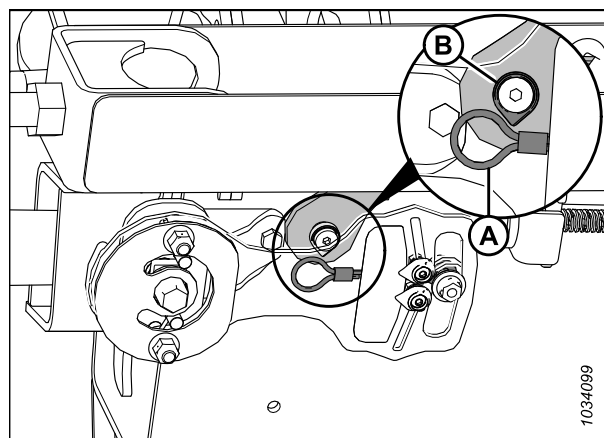


Figure 3.320: Flex Checker Cable Lock – Left Side

**NOTE:**

When the header is attached to a combine and its wings are locked and level with the feed draper deck, lynch pin (A) should point to the center of indicator (B). If lynch pin (A) does **NOT** point to the center of indicator (B) under those conditions, calibrate the indicator by loosening bolts (C) and by adjusting the indicator's position. The indicator should move as the wing flexes. If the indicator remains stuck at either end of the range, refer to [Checking and Adjusting Header Float, page 210](#) and [3.9.4 Checking and Adjusting Wing Balance, page 226](#).

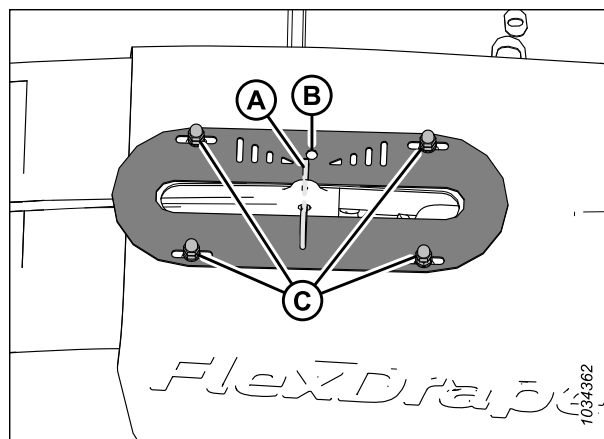


Figure 3.321: Wing Movement Indicator on Top of Flex Linkage Cover – Left Side Shown

13. Close the left endshield. For instructions, refer to [Closing Header Endshields, page 42](#).

## OPERATION

### Operating in Rigid Mode

The header is designed to operate with the cutterbar on the ground. Locking the wings allows the header to operate as a rigid header with the cutterbar straight. When the three sections of the header are locked, the cutterbar is rigid and moves up and down at the same time.

Lock the wings as follows:

1. Move spring handle (A) in the upper slot to lock the wing. You should hear the lock engage.
2. If the lock link does not engage, move the wing by raising and lowering the header, changing the header angle, or by driving the combine until it engages.
3. If the lock still does not engage, proceed to the next step.
4. Remove the flex linkage cover. For instructions, refer to [Removing Inboard Flex Linkage Covers, page 52](#).

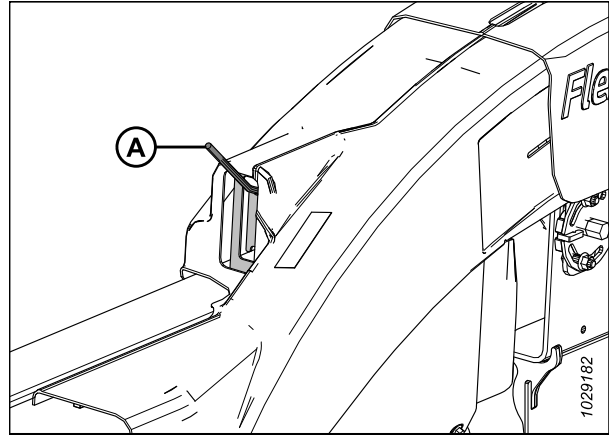


Figure 3.322: Wing in Locked Position

5. Open the left endshield. For instructions, refer to [Opening Header Endshields, page 41](#).
6. Remove hairpin (A) securing multi-tool to the holder bracket on the left endsheet.
7. Remove multi-tool (B) from its storage location. Reinstall the hairpin onto the bracket.

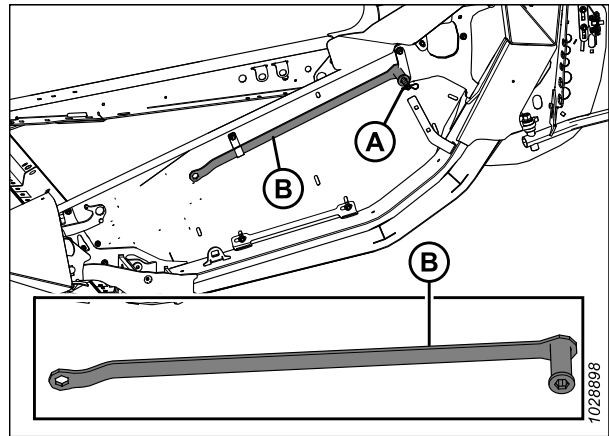


Figure 3.323: Left Endsheets

8. Use multi-tool (A) on plate (B) to move the wing up and down until the lock engages.
9. Return multi-tool (A) to its storage position.
10. Reinstall the flex linkage cover. For instructions, refer to [Installing Inboard Flex Linkage Covers, page 53](#).

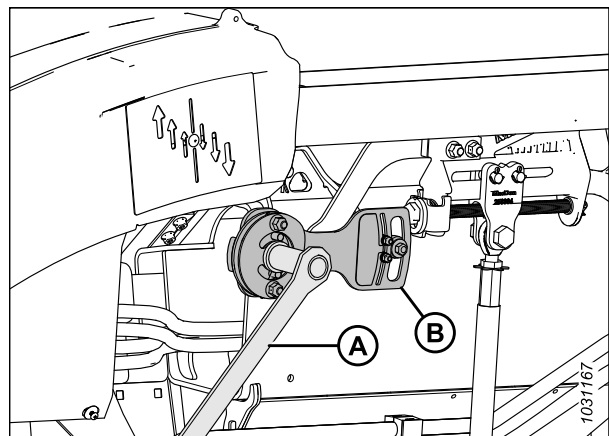


Figure 3.324: Wing in Locked Position

### Disabling Flex Frown Limiter

Disabling the flex frown limiter increases the extent to which the header wings can flex. You may wish to disable the flex frown limiter to improve the header's ability to adjust to changes in the terrain elevation and/or when you are harvesting tall crops such as standing cereals and canola.

#### DANGER

Ensure that all bystanders have cleared the area.

#### DANGER

To prevent bodily injury or death from the unexpected start-up or fall of a raised machine, always stop the engine and remove the key before leaving the operator's seat, and always engage the safety props before going under the machine for any reason.

#### NOTE:

After removing the flex frown limiter plate, you will need to adjust the clearance between the reel and the cutterbar. Refer to [4.13.1 Reel-to-Cutterbar Clearance, page 720](#) for specifications.

1. Park the combine on a level surface.
2. Lock the header wings. For instructions, refer to [Operating in Rigid Mode, page 224](#).
3. Extend the hydraulic center-link fully.
4. Lower the header fully.
5. Shut down the engine, and remove the key from the ignition.
6. Remove two bolts (A).
7. Remove flex frown limiter plate (B).
8. Store bolts (A) and flex frown limiter (B) in the manual storage case.
9. Repeat Step 6, [page 225](#) to Step 8, [page 225](#) to remove the flex frown limiter and hardware on the other side of the float module.
10. Adjust the reel finger clearance. For instructions, refer to [4.13.1 Reel-to-Cutterbar Clearance, page 720](#).

#### IMPORTANT:

Adjusting the reel-to-cutterbar clearance is necessary to prevent the cutterbar from cutting off reel fingers when the wings flex.

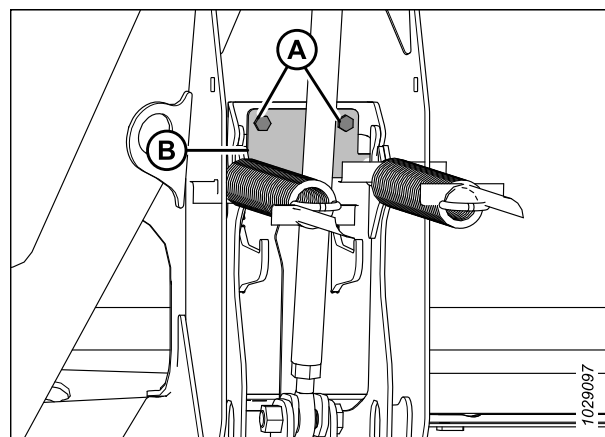


Figure 3.325: Flex Frown Limiter Plate

### Enabling Flex Frown Limiter

Enabling the flex frown limiter limits the header's ability to frown, allowing the reel to be very close to the cutterbar. A close reel-to-cutterbar relationship is ideal when harvesting short crops such as lentils, lodged peas, or short soybeans.

#### DANGER

Ensure that all bystanders have cleared the area.

**⚠ DANGER**

To prevent bodily injury or death from the unexpected start-up or fall of a raised machine, always stop the engine and remove the key before leaving the operator's seat, and always engage the safety props before going under the machine for any reason.

**NOTE:**

After installing the flex float limiter plate, you will need to adjust the clearance between the reel and the cutterbar. Refer to [4.13.1 Reel-to-Cutterbar Clearance, page 720](#) for specifications.

1. Park the combine on a level surface.
2. Lock the header wings. For instructions, refer to [Operating in Rigid Mode, page 224](#).
3. Lower the header fully.
4. Extend the hydraulic center-link fully.
5. Shut down the engine, and remove the key from the ignition.
6. Retrieve the two flex frown limiter plates and hardware from the header's manual storage case.
7. On the left side of the header, position flex frown limiter (B) as shown.
8. Secure the limiter with two bolts (A).
9. Repeat the previous two steps to install the flex frown limiter on the right side of the float module.
10. Adjust the reel finger clearance. For instructions, refer to [Adjusting Reel-to-Cutterbar Clearance, page 724](#) for specifications.

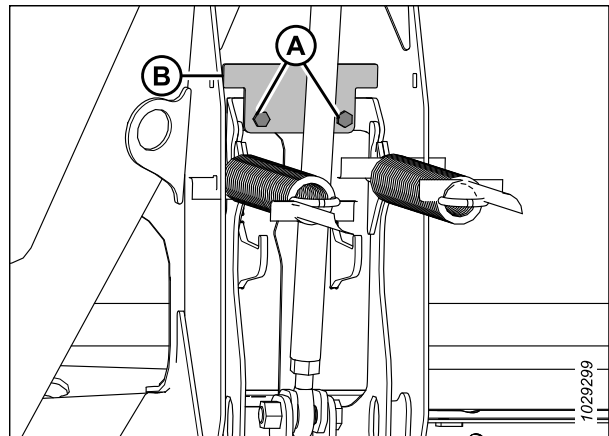


Figure 3.326: Flex Frown Limiter Plate

### 3.9.4 Checking and Adjusting Wing Balance

The wing balance is a critical factor for ensuring that the header follows the contours of the ground closely. If set too light, the wings will bounce or not follow ground contours, leaving uncut crop. If set too heavy, the end of the header will dig into the ground.

**⚠ DANGER**

Ensure that all bystanders have cleared the area.

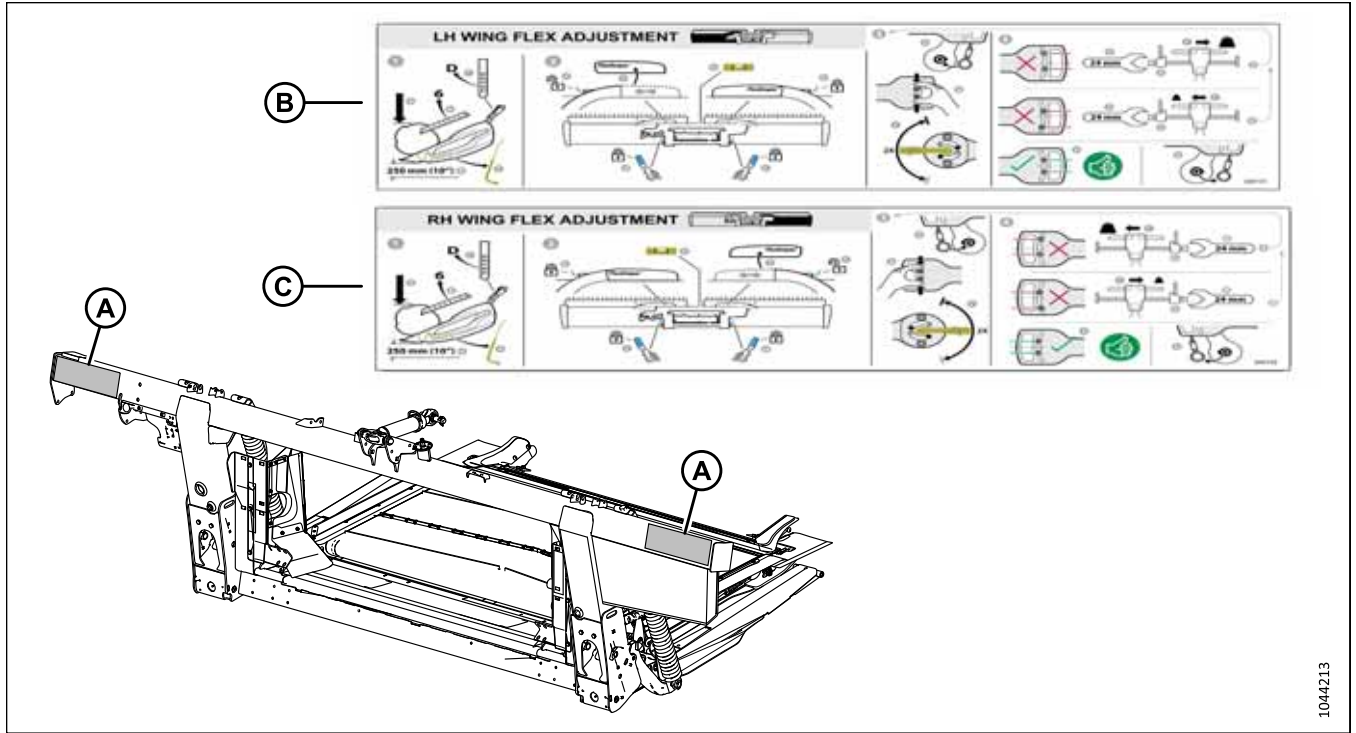
**⚠ DANGER**

To prevent bodily injury or death from the unexpected start-up of the machine, always stop the engine and remove the key from the ignition before making adjustments to the machine.

**IMPORTANT:**

Ensure that the header float is set properly for accurate wing balance readings. For instructions, refer to [Checking and Adjusting Header Float, page 210](#). The float module must be sitting level before performing any adjustments.

## OPERATION



1044213

**Figure 3.327: Decal Locations – LH Wing Adjustment (B) and RH Wing Adjustment (C)**

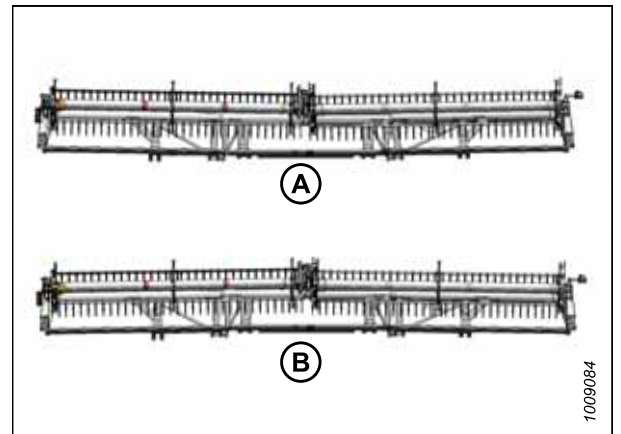
**NOTE:**

This procedure is summarized on decals (B) and (C) for left wing and right wing adjustment, respectively, on locations (A).

**NOTE:**

The header wings are balanced when it takes an equal amount of force to move a wing up or down.

If the header wings tend to be in a smile (A) or a frown (B) position, and the header is missing crop or pushing soil, adjust the wing balance.



1009084

**Figure 3.328: Wing Imbalance**



## OPERATION

1. Adjust the reel fore-aft position so that the indicator on left indicator bracket (A) is at position 6.
2. Lower the reel fully.

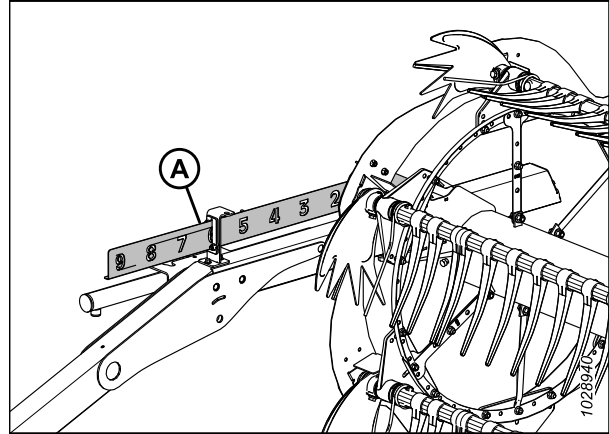


Figure 3.329: Fore-Aft Position

3. Adjust center-link (A) so that indicator (B) is at position D on the gauge.
4. **Headers with transport wheels or stabilizer wheels installed:** Move the wheels so that they are supported by the header.
  - For transport wheels, refer to *Adjusting EasyMove™ Transport Wheels, page 191*.
  - For stabilizer wheels, refer to *Extending/Retracting Contour Wheels using Foot Switch, page 192*.

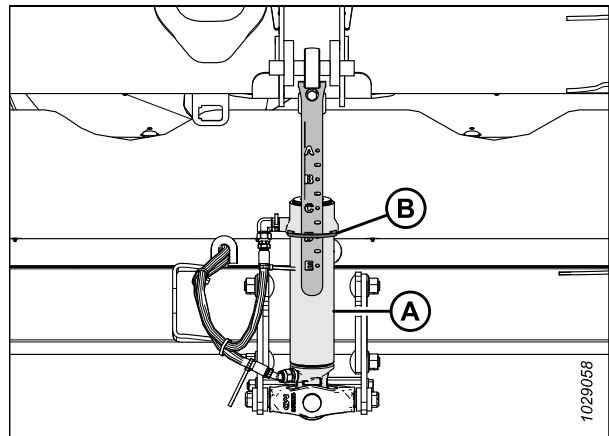


Figure 3.330: Center-Link

5. Park the combine on a level surface.
6. Position the header so that the cutterbar is 254–356 mm (10–14 in.) off the ground.
7. Ensure that the header is level with the ground. If adjustment is required:
  - Ensure that the combine is parked on a level surface.
  - If equipped, use the combine's lateral tilt to level the feeder house with the ground.
  - If further adjustment is required, shut the engine off, remove the key from the ignition, and ensure that the combine's tires are inflated to the correct pressure.

### NOTE:

Spirit level (A) is located on top of the float module frame. The header is level if the bubble is in the center of the spirit level.

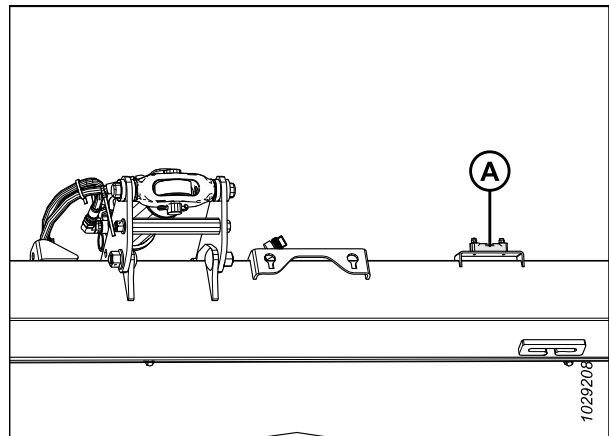


Figure 3.331: Spirit Level

8. Shut down the engine, and remove the key from the ignition.
9. Remove the linkage cover. For instructions, refer to *Removing Inboard Flex Linkage Covers, page 52*.



## OPERATION

- Attach flex checker cable (A) to flex checker cable lock (B).

### NOTE:

Some parts have been made transparent in the illustration to better show the cable lock.

- Open the left header endshield. For instructions, refer to [Opening Header Endshields, page 41](#).

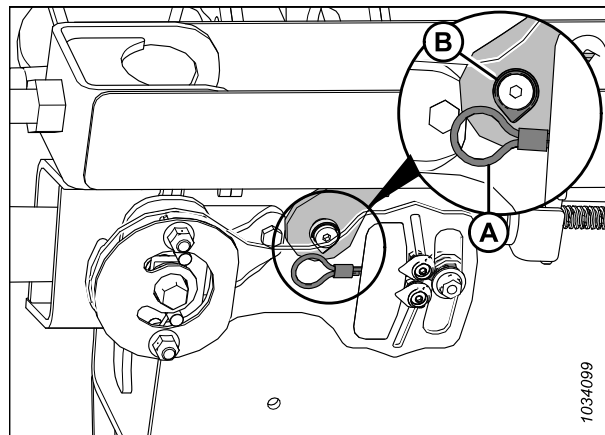


Figure 3.332: Left Flex Checker Cable Lock

- Remove hairpin (A) securing the multi-tool to the bracket on the left endshield.
- Remove multi-tool (B). Reinstall the hairpin.

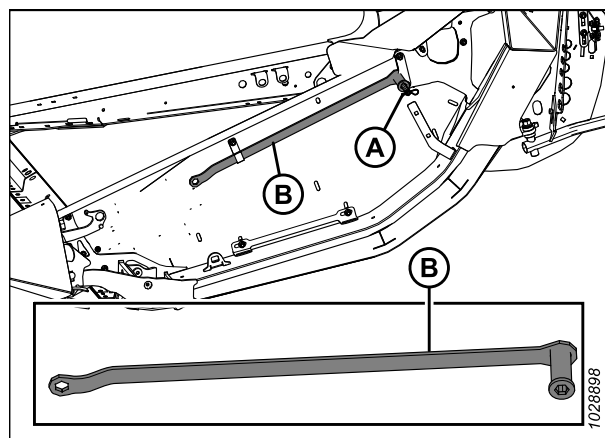


Figure 3.333: Left Endshield

- Unlock the wing that you are checking by moving spring handle (A) to the lower UNLOCK position. Unlock **ONLY** the wing being checked. Ensure that the other wing is locked.

### NOTE:

You should hear a click after moving the spring handle; this click indicates that the internal mechanism has engaged or disengaged.

- If the internal lock mechanism does not engage, move the wing with multi-tool (B) until you hear a click.

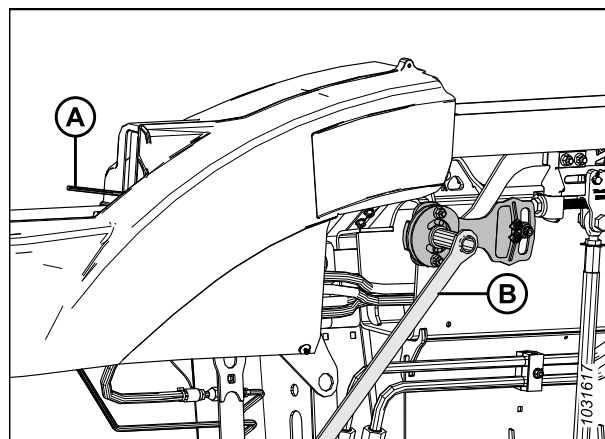


Figure 3.334: Wing Unlocked Position

## OPERATION

16. Ensure that float levers (A) are disengaged (down) on both sides of the float module.
17. Ensure that float locks (B) are engaged (up) on both sides of the float module.

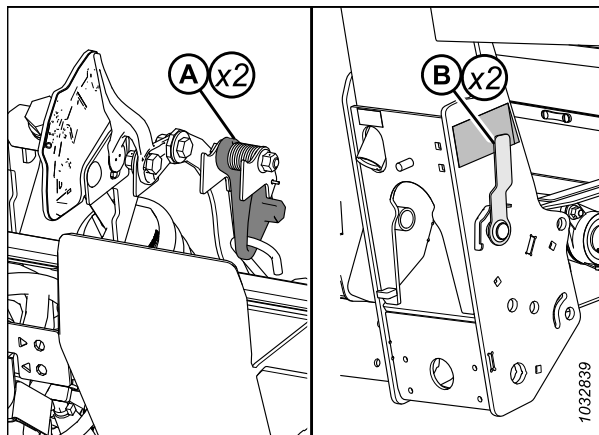


Figure 3.335: Checker Plate Assembly

18. On the flex checker plate, pinch indicators (A) and (B) together with your fingers.
19. Use multi-tool (C) to rotate the flex checker plate up until the pin reaches the end of the slot. Lower indicator (B) will move down to give the first reading.
20. Use multi-tool (C) to rotate the flex checker plate down until the pin reaches the end of the slot. Upper indicator (A) will move up to give the second reading.

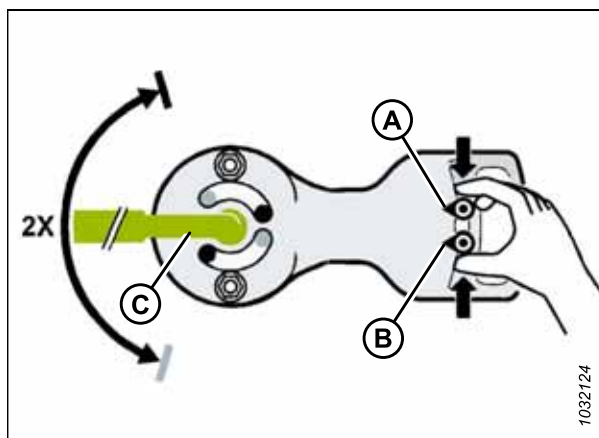


Figure 3.336: Left Wing Balance Indicators

## OPERATION

21. Interpret the reading on the flex checker plate as follows:

- If the wing is too light (A), make it heavier by depressing flex adjustment lock (H) and turning adjuster bolt (D) to move clevis (E) in direction (F). Recheck the wing balance. Adjust the balance as needed until the wing is balanced (C). Once adjustment is completed, turn bolt (D) to engage flex adjustment lock (H).
- If the wing is too heavy (B), make it lighter by depressing flex adjustment lock (H) and turning adjuster bolt (D) to move clevis (E) in direction (G). Recheck the wing balance. Adjust the balance as needed until the wing is balanced (C). Once adjustment is completed, turn bolt (D) to engage flex adjustment lock (H).
- If the wing is balanced (C), no action is required. Proceed to the next step.

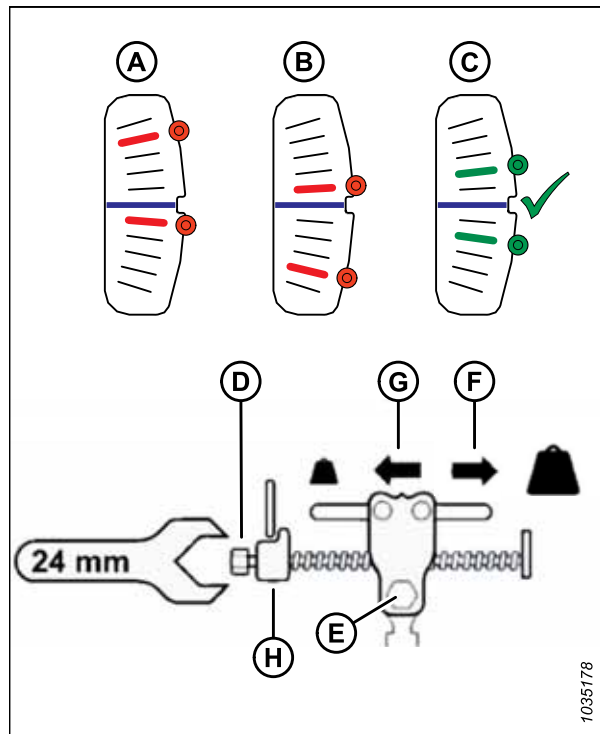


Figure 3.337: Left Wing Balance Adjustment Checker Plate

22. Move the spring handle to the upper **LOCK** position (A).

**NOTE:**

If the lock does not engage, move the wing up and down with the multi-tool until it engages.

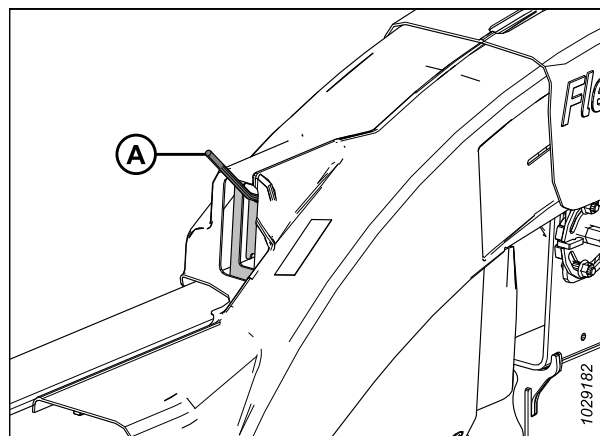


Figure 3.338: Spring Handle – LOCK Position

## OPERATION

23. Remove flex checker cable (A) from flex checker cable lock (B).

### IMPORTANT:

The flex checker cable may be damaged if it is left in place.

24. Repeat this procedure to set the wing balance on the other wing.

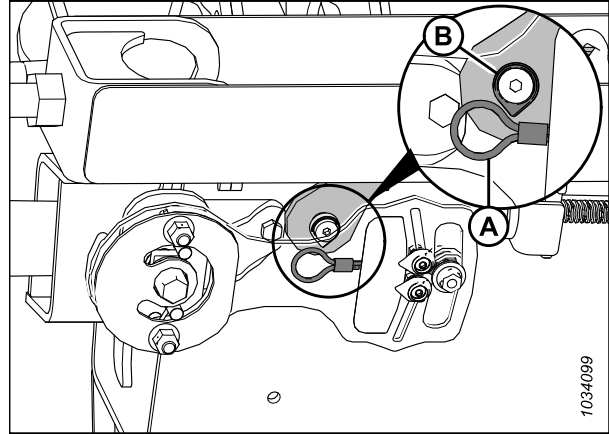


Figure 3.339: Left Flex Checker Cable Lock

25. Return multi-tool (B) to its storage position. Secure the multi-tool with hairpin (A).
26. Reinstall the linkage covers.
- For the outboard flex linkage covers, refer to *Installing Outboard Flex Linkage Covers*, page 55.
  - For the inboard flex linkage covers, refer to *Installing Inboard Flex Linkage Covers*, page 53.
27. If the cutterbar is not straight when the wings are locked, then further adjustments to the header are needed. Contact your Dealer.

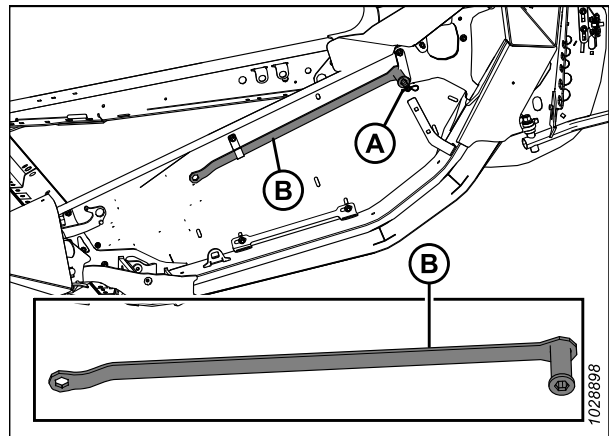


Figure 3.340: Multi-Tool Storage

### 3.9.5 Header Angle

You can adjust the header angle to accommodate different crop conditions and/or soil types by using the center-link between the combine and the header.

Refer to *Adjusting Header Angle from Combine*, page 234 for combine-specific adjustment details.

Header angle (A) is the angle between the header and the ground.

When cutting the crop at ground level, the header angle controls distance (B) between the cutterbar knife and the ground.

Adjusting the header angle pivots the header at the point of skid shoe/ground contact (C).

Guard angle (D) is the angle between the upper surface of the cutterbar guards and the ground.

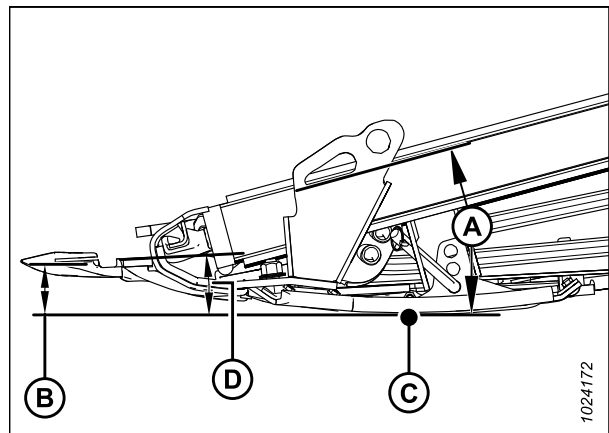


Figure 3.341: Header Angle

## OPERATION

Shallowest angle (A) (center-link fully retracted) is at 1.7°, and produces the highest stubble when cutting on the ground.

Steepest angle (E) (center-link fully extended) is at 8.9°, and produces the lowest stubble when cutting on the ground.

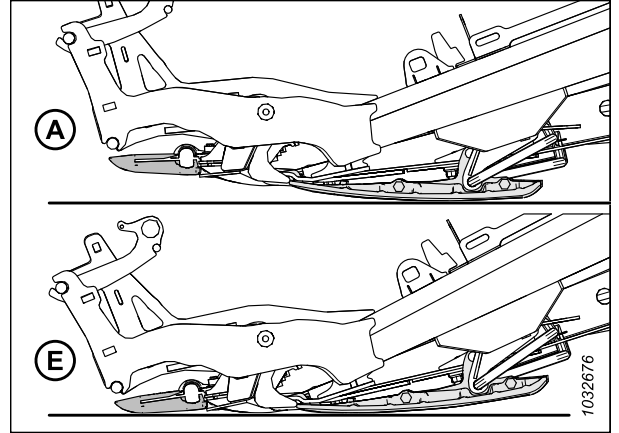


Figure 3.342: Guard Angles

Set the header angle according to the type and the condition of the crop and the soil as follows:

- Use shallower settings (A) (position A on the indicator) for normal cutting conditions and for wet soil to prevent the soil from building up at the cutterbar. A shallow header angle also minimizes knife damage in stony fields.
- Use steeper settings (E) (position E on the indicator) for lodged crops and crops that are close to the ground such as soybeans.

Choose a header angle that maximizes the header's performance for your crop and field conditions.

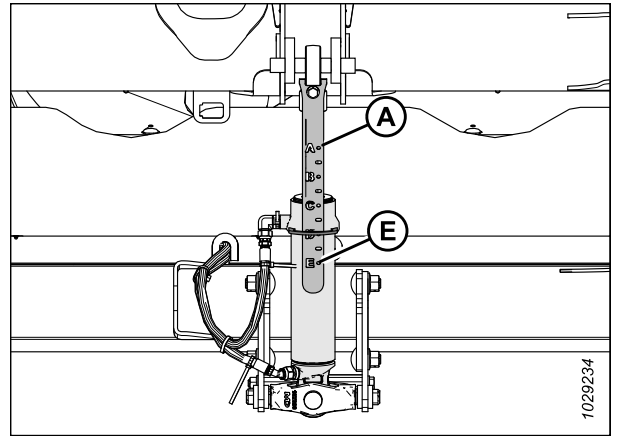


Figure 3.343: Center-Link

## OPERATION

### *Adjusting Header Angle from Combine*

The header angle is adjusted from the combine cab using a switch on the operator's control handle and an indicator on the center-link or on the monitor in the cab. The header angle is determined by the length of the center-link between the combine float module and the header, or by the degree of feeder house tilt on certain combine models.

#### **Case combines:**

Case combines use control handle switches to adjust the center-link to change the header angle.

1. Hold SHIFT button (A) behind the control handle and press switch (B) to tilt the header forward or press switch (C) to tilt the header back.



Figure 3.344: Case Combine Controls

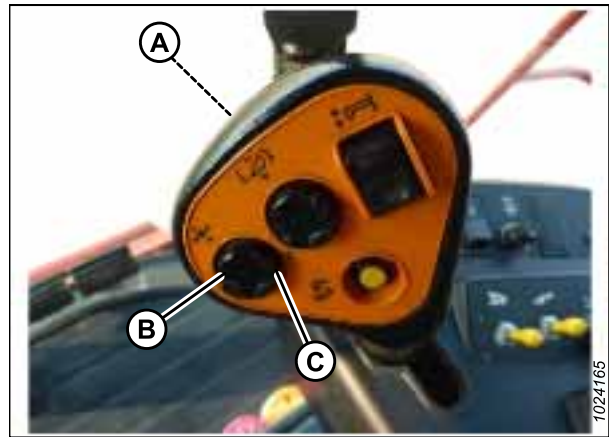


Figure 3.345: Case Combine Controls

#### **Challenger®, Gleaner®, and Massey Ferguson® combines:**

Challenger®, Gleaner®, and Massey Ferguson® combines use a combination of the reel fore-aft switches on the control handle and a Dealer-installed auxiliary rocker switch, which toggles between reel fore-aft and header tilt functionality.

## OPERATION

### NOTE:

The location of the rocker switch varies with the combine model.

1. **Gleaner® A only:** Open armrest cover (A) to expose a row of switches.
2. Press Dealer-installed rocker switch (B) to HEADER TILT position.

### NOTE:

A Gleaner® A console is shown in the image; other Challenger® and Massey Ferguson® combine models have a rocker switch on the console (not shown).

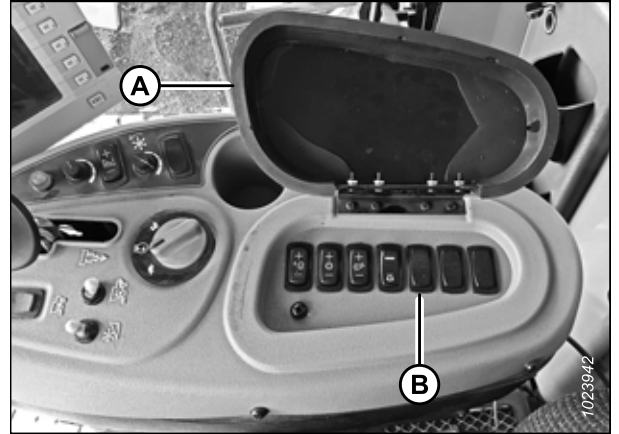


Figure 3.346: Gleaner® A Console

3. To tilt the header forward to a steeper angle, press button (A) on the control handle. To tilt the header back to a shallower angle, press button (B) on the control handle.



Figure 3.347: Gleaner® S9 Controls

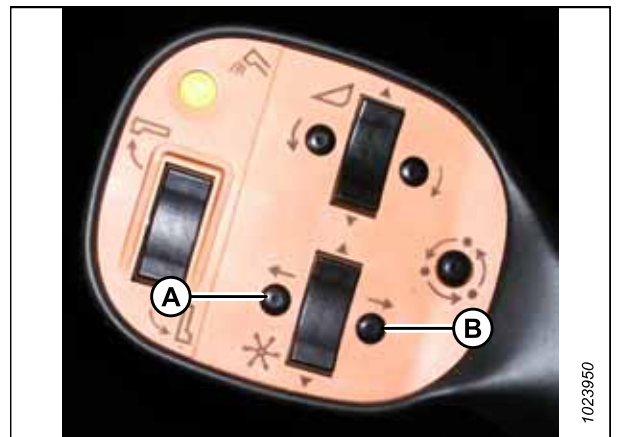


Figure 3.348: Gleaner® R65/75 Controls



## OPERATION



Figure 3.349: Challenger®/Massey Ferguson® Controls

### **CLAAS combines:**

**CLAAS (with a factory-installed fore-aft / header tilt switch):** Newer CLAAS combines use a combination of the reel fore-aft switches on the control handle and a factory-installed auxiliary rocker switch which toggles between reel fore-aft and header tilt functionality.

1. Press HOTKEY switch (A) on the operator's console to deck plate position (the header icon [B] with the arrows pointing to each other).

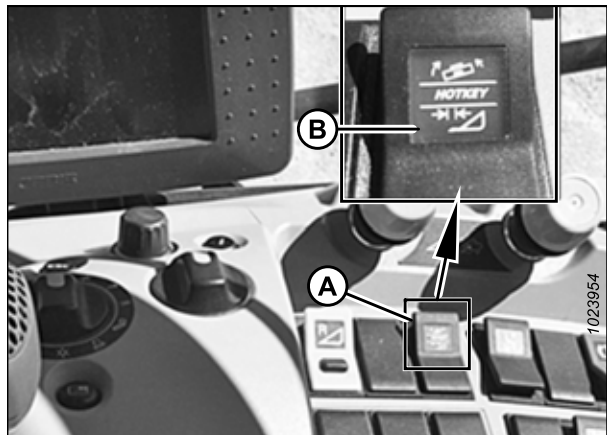


Figure 3.350: CLAAS 700 Console



## OPERATION

2. Press and hold switch (A) behind the control handle.
3. To tilt the header forward (steeper angle), press switch (C).  
To tilt the header back (shallower angle), press switch (B).

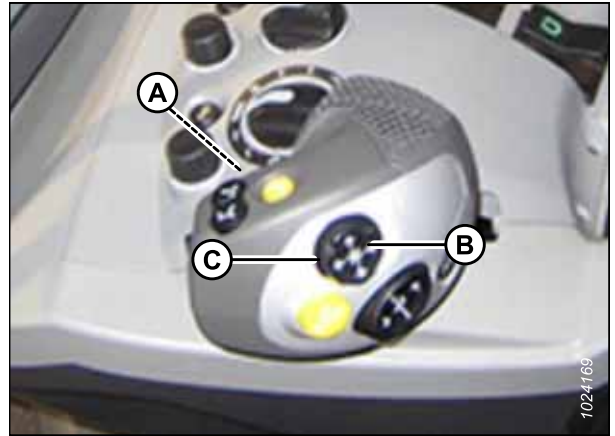


Figure 3.351: CLAAS 5000, 6000, 7000 or 8000 Control Handle

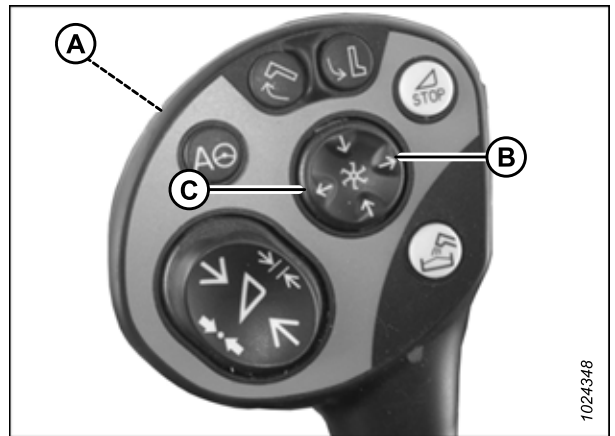


Figure 3.352: CLAAS 500, 600, or 700 Control Handle

### *John Deere combines:*

**John Deere S700:** S700 Series combines can use a feeder house deckplate tilting system for feeder house fore-aft adjustment. Set the deckplate at a mid-point position, and use the MacDon fore-aft header tilt system.

### **IMPORTANT:**

Damage to equipment may occur if both the deckplate and MacDon header tilt are adjusted to their maximum range.

## OPERATION

1. To tilt the header forward (steeper angle), press switch (A).  
To tilt the header back (shallower angle), press switch (B).



Figure 3.353: John Deere 700 Feeder House Fore-Aft Tilt Controls

**John Deere (except S700 Series):** Other John Deere combines use a combination of the reel fore-aft switches on the control handle and a Dealer-installed auxiliary rocker switch which toggles between reel fore-aft and header tilt functionality.

1. Press reel fore-aft / header tilt switch (A) on the console into HEADER TILT position.

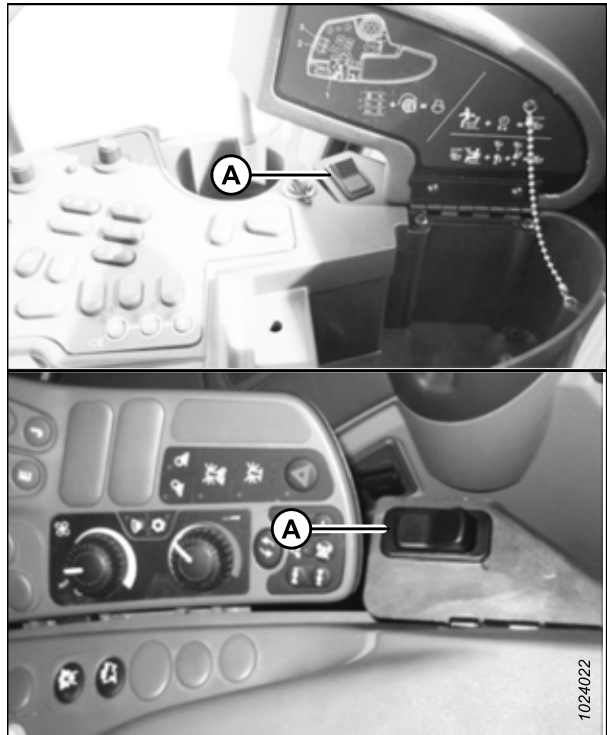


Figure 3.354: John Deere Consoles

## OPERATION

- To tilt the header forward (steeper angle), press switch (A).  
To tilt the header back (shallower angle), press switch (B).



Figure 3.355: John Deere Control Handle

### ***New Holland combines:***

New Holland combines use control handle switches to adjust the center-link to change the header angle.

- Hold SHIFT button (A) behind the control handle and press switch (B) to tilt the header forward to a steeper angle or press switch (C) to tilt the header back to a shallower angle.

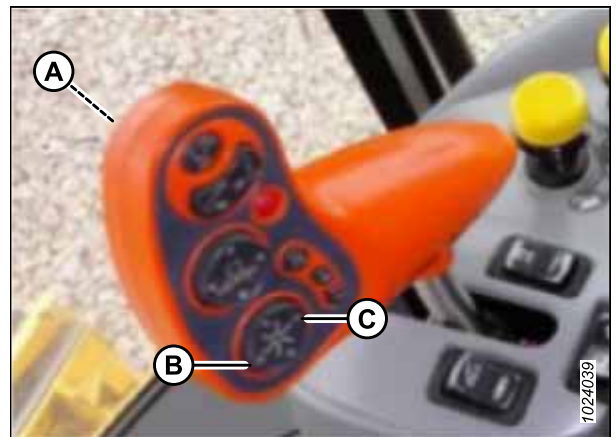


Figure 3.356: New Holland CR/CX Controls

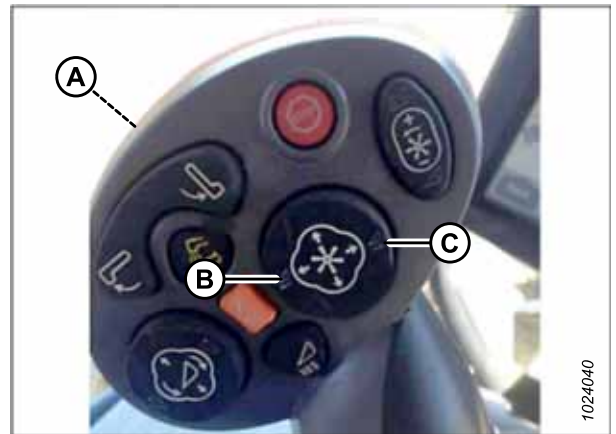


Figure 3.357: New Holland CR/CX Controls

## OPERATION

### *Rostselmash combines:*

Rostselmash combines use a combination of reel fore-aft switches on the control handle and a factory-installed auxiliary rocker switch on the combine control console that toggles between reel fore-aft and header tilt functionality.

1. Press ON switch (A) on the console to place the controls in HEADER TILT mode.
2. To tilt the header forward to a steeper angle, press button (B) on the control handle. To tilt the header back to a shallower angle, press button (C) on the control handle.

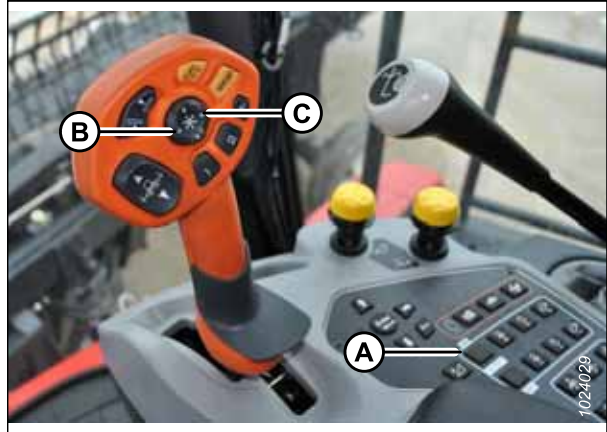


Figure 3.358: Rostselmash Controls

### 3.9.6 Reel Speed

The reel speed helps control how crop moves from the cutterbar onto the drapers.

The reel performs best when it appears to be driven by the ground. It should move the cut crop evenly through the cutterbar and onto the drapers without bunching and with minimal disturbance.

In standing crop, the reel speed should be slightly higher than or equal to the ground speed.

In flattened crop or crop that leans away from the cutterbar, the reel speed must be higher than the ground speed. To achieve this, either increase the reel speed or decrease the ground speed.

Excessive shattering of grain heads or crop loss over the header backtube may indicate that the reel speed is too high. Excessive reel speed also increases reel component wear and overloads the reel drive.

#### **NOTE:**

Excessive reel speed will also cause the reel circuit to go over relief. The reel will speed up and slow down at each bat when operating in heavy, tough, and lodged crops. Reducing the reel speed, so it is closer to the ground speed, will still allow the reel to lift the crop while not trying to pull it out of the ground. This will also reduce seed loss from the reel trying to comb through the crop, instead of just lifting it.

For recommended reel speeds in specific crops and conditions, refer to [3.7.2 Header Settings, page 141](#).

You can adjust the reel speed using the controls in the combine cab. For instructions, refer to the combine operator's manual.

#### *Optional Reel Drive Sprockets*

Optional sprockets for use in specific crop conditions are available as an alternative to the factory-installed single sprocket.

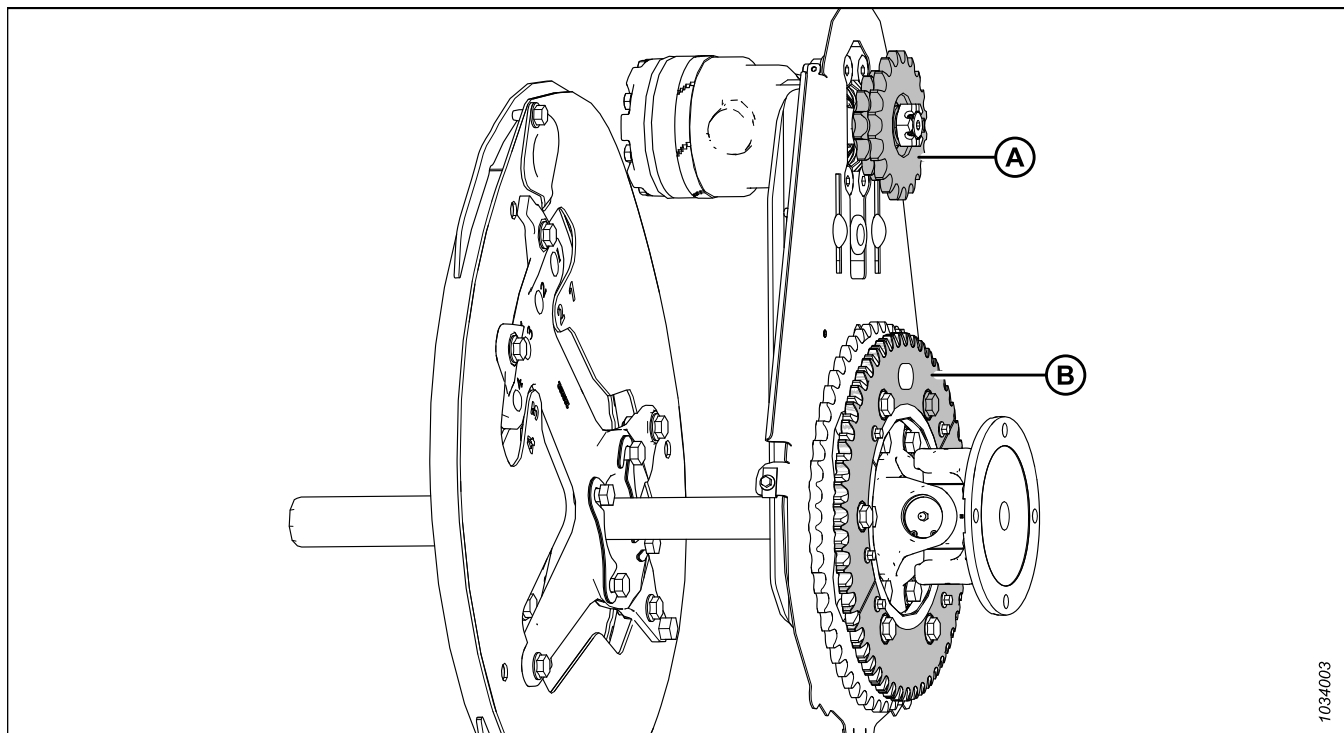
The header is factory-equipped with a 19-tooth reel drive single sprocket, which is suitable for most crops.

Replacing the 19-tooth reel drive single sprocket with optional dual reel drive sprocket (A) will provide more torque to the reel in heavy cutting conditions.

With the optional dual reel drive sprocket installed, an optional 52-tooth sprocket (B) can also be added on top of the existing 56-tooth lower sprocket that will allow for higher reel speed in light crops when operating at increased ground speed.

## OPERATION

With these two optional sprockets installed, switching from high-torque to high-speed and vice versa will be quick and easy. For sprocket information, refer to Table 3.21, page 241, 3.22, page 241 3.23, page 242. Contact your Dealer for more information.



**Figure 3.359: Reel Drive with Optional Sprockets**

A - Dual Reel Drive Sprocket (MD #273451, MD #273452, or MD #273453)<sup>59</sup>

B - 52-Tooth Sprocket (MD #273689)<sup>60</sup>

**Table 3.21 Optional Sprockets**

Sprocket	Machine Hydraulics	Combine	Application	Optional Drive Sprocket
Dual reel drive sprocket (A)	13.79 MPa (2000 psi)	Gleaner® Transverse Rotary	Combining down rice	10/20 tooth
Dual reel drive sprocket (A)	17.24 MPa (2500 psi)	CLAAS 500, 700 Series, Challenger® Axial Rotary	Combining down rice	12/20 tooth
Lower sprocket (B)	—	All	Light crops	52 tooth

**Table 3.22 Optional Sprockets (Case)**

Sprocket	Machine Hydraulics	Combine	Application	Optional Drive Sprocket
Dual reel drive sprocket (A)	13.79 MPa (2000 psi)	Case IH 7010, 8010, 7120, 8120, 88 Series	Combining down rice	10/20 tooth
Lower sprocket (B)	—	All	Light crops	52 tooth

59. These sprockets are sold separately (individual parts).

60. This sprocket is included in kit MD #311882.

## OPERATION

**Table 3.23 Optional Sprockets (New Holland)**

Sprocket	Machine Hydraulics	Combine	Application	Optional Drive Sprocket
Dual reel drive sprocket (A)	20.68 MPa (3000 psi)	New Holland CR, CX	Combining down rice	14/20 tooth
Lower sprocket (B)	—	All	Light crops	52 tooth

### 3.9.7 Ground Speed

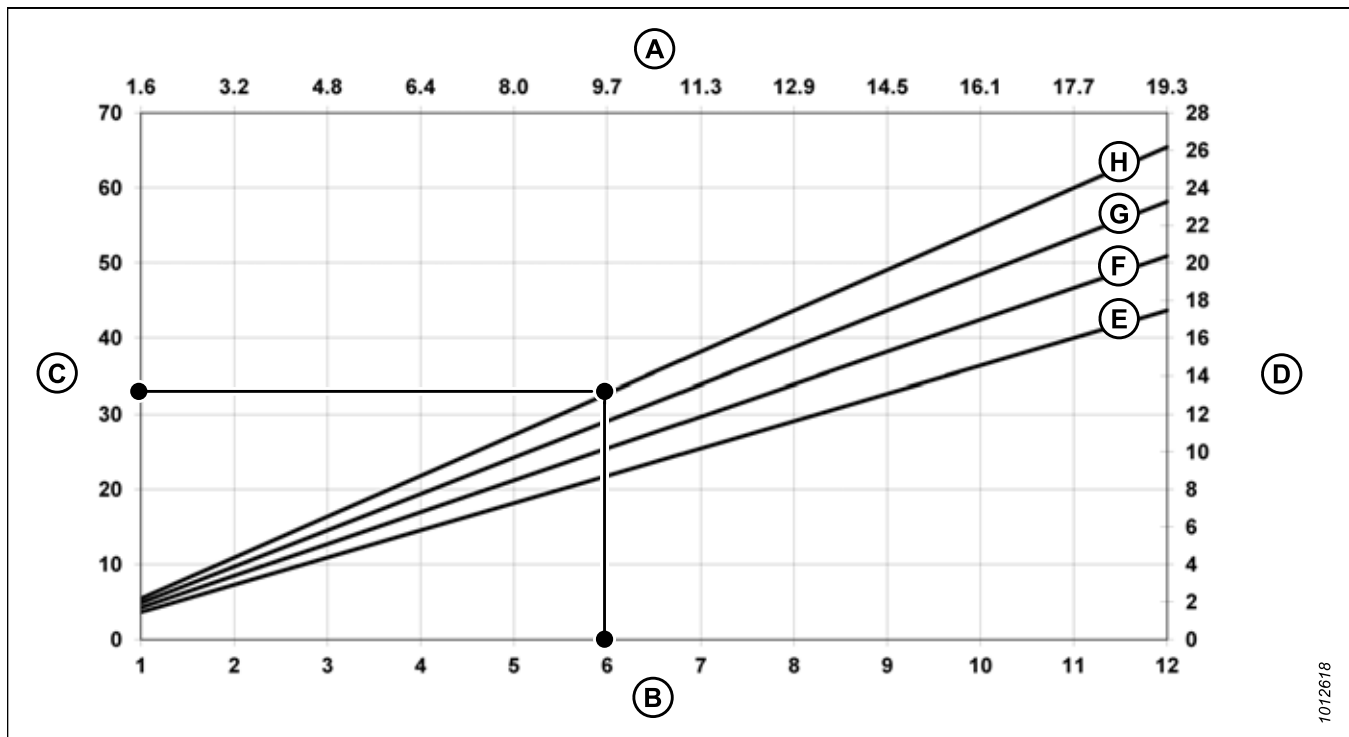
Operating the header at an appropriate ground speed results in cleanly cut crop and even feeding.

Reduce the vehicle's ground speed in difficult cutting conditions to reduce equipment wear.

When harvesting very light crops (for example, short soybeans), use lower ground speeds to allow the reel to pull in short plants. Start at 4.8–5.8 km/h (3.0–3.5 mph) and adjust the speed as needed.

Higher ground speeds may require heavier float settings to prevent the header from bouncing. If you increase the ground speed, increase the speed of the draper and the reel to handle the extra material.

Figure 3.360, page 242 illustrates the relationship between the ground speed and the area cut for the various sized headers.



**Figure 3.360: Ground Speed versus Acres**

A - Kilometers/Hour  
D - Hectares/Hour  
G - 12.2 m (40 ft.)

B - Miles/Hour  
E - 9.1 m (30 ft.)  
H - 13.7 m (45 ft.)

C - Acres/Hour  
F - 10.7 m (35 ft.)

**Example:** A 12.2 m (40 ft.) header operating at a ground speed of 9.7 km/h (6 mph) would produce a cut area of approximately 11.3 hectares (28 acres) in one hour.

### 3.9.8 Side Draper Speed

Operating with the correct draper speed is important for achieving the desired flow of cut crop away from the cutterbar.

Optimize the side draper speed for crop density, ground speed, and feeder house capacity. Side drapers that run too fast will pull crop off of the cutterbar and can result in crop bunching at the feed draper. Side drapers that run too slow will allow the feed draper to pull crop off of the side drapers and can result in uneven feeding.

Adjust the side draper speed to efficiently feed crop onto the float module feed draper. For instructions, refer to [Adjusting Side Draper Speed, page 243](#).

#### *Adjusting Side Draper Speed*

The side drapers carry the cut crop to the float module feed draper, which then feeds the crop into the combine. You can adjust the speed of the side drapers for various crops and crop conditions.

Side drapers (A) are driven by hydraulic motors and by a pump that is powered by the combine feeder house drive through a gearbox on the float module. From inside the cab, you can adjust the side draper speed on the side draper speed control, which regulates the flow to the draper hydraulic motors.

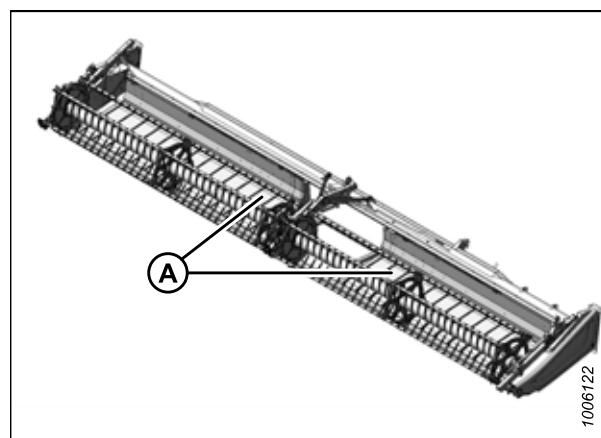


Figure 3.361: Side Drapers

#### **Combines with integrated controls**

Use the integrated draper controls to set the draper speed. For instructions, refer to the combine operator's manual.

For the recommended header settings, refer to one of the following:

- [3.7.2 Header Settings, page 141](#)
- [3.7.3 Optimizing Header for Straight-Combining Canola, page 152](#)

#### **NOTE:**

For John Deere X9 combines, use each increment of ten for each number (that is, 10 = 1).

#### **NOTE:**

For Case IH and New Holland combine compatibility with integrated draper speed controls, refer to the combine operator's manual.



## OPERATION

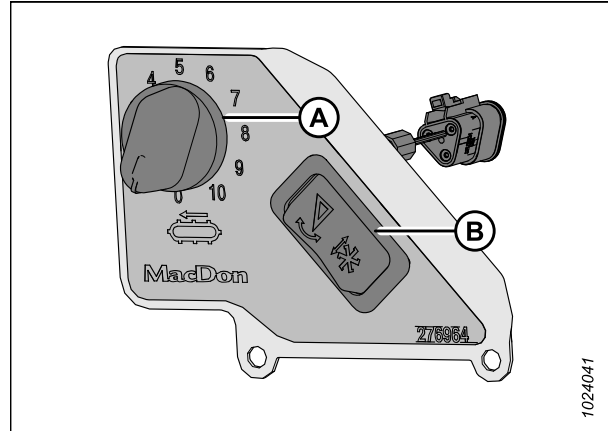
### **Combines with MacDon In-Cab Side Draper Speed Control**

Rotate knob (A) to set the draper speed. For the recommended header settings, refer to one of the following:

- [3.7.2 Header Settings, page 141](#)
- [3.7.3 Optimizing Header for Straight-Combining Canola, page 152](#)

#### **NOTE:**

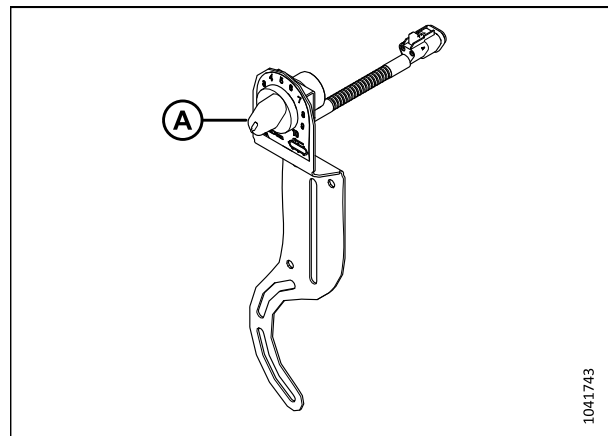
Switch (B) in Figure 3.362, [page 244](#) allows the operator to switch between the header tilt and reel fore-aft controls. For instructions on the controls, refer to [Adjusting Header Angle from Combine, page 234](#).



**Figure 3.362: In-Cab Side Draper Speed Control**

#### **NOTE:**

For Case IH and New Holland combines, the switch to activate the header tilt and reel fore-aft controls is located behind the ground speed lever (GSL).



**Figure 3.363: Case IH and New Holland In-Cab Side Draper Speed Control**

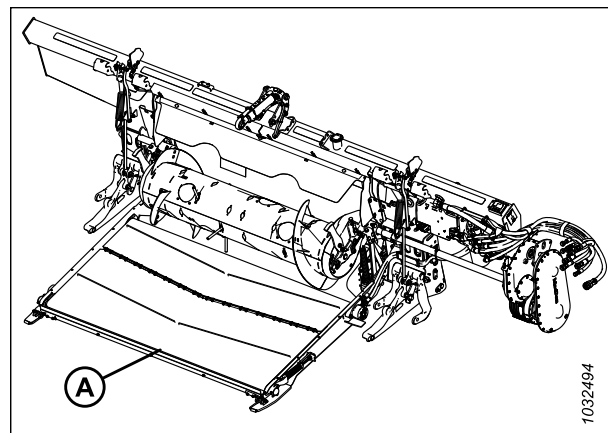
## 3.9.9 Feed Draper Speed

The feed draper moves the cut crop from the side drapers into the float module feed auger.

Float module feed draper (A) is driven by a hydraulic motor and a pump that is powered by the combine feeder house drive through a gearbox on the float module.

#### **IMPORTANT:**

The feed draper speed is determined by the combine feeder house speed and cannot be independently adjusted.



**Figure 3.364: FM200 Float Module**



### 3.9.10 Knife Speed Information

The float module is driven by a driveline that is attached to the combine feeder house. The driveline attaches to a gearbox that drives the knife drive pump.

**Table 3.24 Feeder House Speed**

Combine Make	Feeder House Speed (rpm)
Case IH	580
Challenger®	625
CLAAS 500/600/700	Display Speed: 420 Actual Shaft Speed: 750
CLAAS 6000/7000/8000 Series CLAAS Trion 600/700 Series	785
Gleaner®	625
IDEAL™	620
John Deere <sup>61</sup>	490
Massey Ferguson®	625
New Holland	580
Rostselmash	580

**Table 3.25 FD2 Series Header Knife Speed**

Header	Recommended Knife Drive Speed Range (rpm)	
	Single-Knife Drive	Double-Knife Drive
FD225	600–700	—
FD230	600–750	—
FD235	600–700	600–750
FD240	600–650	600–750
FD241	—	600–750
FD245	—	600–750
FD250	—	600–750

**IMPORTANT:**

Ensure that the knife speed is within the range of rpm values in Table 3.25, page 245. For instructions, refer to *Checking Knife Speed*, page 245.

**IMPORTANT:**

To prevent the knife from overspeeding, set the knife speed while the feeder house speed is to set maximum speed.

#### *Checking Knife Speed*

For best performance, the header's knife drive must run within the specified rpm range. You can check the knife speed by using a photo tachometer at the flywheel of the knife drive motor.



### **DANGER**

To prevent injury or death from the unexpected start-up of the machine, always stop the engine and remove the key from the ignition before leaving the operator's seat for any reason.

61. Some John Deere combines have a fixed feeder house speed of 520 rpm. For hydraulic testing purposes, this difference is not significant.

**DANGER**

Ensure that all bystanders have cleared the area.

1. Shut down the engine, and remove the key from the ignition.
2. Open the endshield. For instructions, refer to *Opening Header Endshields, page 41*.
3. Start the engine.
4. Engage the header drive, and run the feeder house at the maximum speed. For maximum speed information, refer to *Table 3.26, page 246*.

**IMPORTANT:**

Before checking the knife speed, make sure the feeder house is set to maximum speed. This will prevent the knife from overspeeding when making further adjustments.

5. Run the float module and the header until the oil temperature is 38°C to 52°C (100°F to 125°F).

6. Measure the rpm of flywheel (A) with a hand-held photo tachometer.

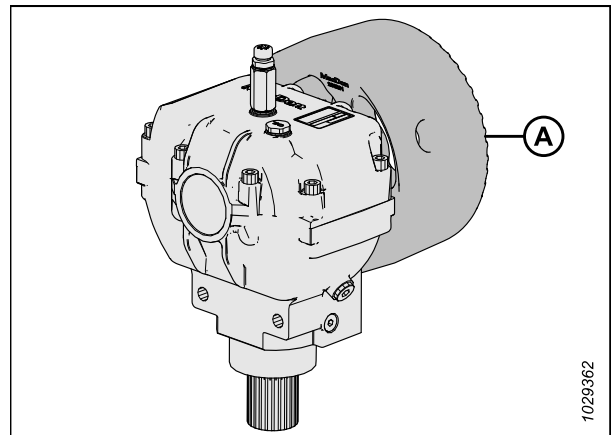
**NOTE:**

One revolution (rpm) is equivalent to two knife strokes (spm) (1 rpm = 2 spm).

7. Shut down the engine, and remove the key from the ignition.

**Table 3.26 Feeder House Speed**

Combine Make	Feeder House Speed (rpm)
Case IH	580
Challenger®	625
CLAAS 500/600/700	Display Speed: 420 Actual Shaft Speed: 750
CLAAS 6000/7000/8000 Series CLAAS Trion 600/700 Series	785
Gleaner®	625
IDEAL™	620
John Deere <sup>62</sup>	490
Massey Ferguson®	625
New Holland	580
Rostselmash	580



**Figure 3.365: Flywheel**

62. Some John Deere combines have a fixed feeder house speed of 520 rpm. For hydraulic testing purposes, this difference is not significant.

## OPERATION

8. Compare the flywheel rpm measurement with the rpm values in [3.27, page 247](#).
9. Contact your Dealer if the pulley rpm measurement exceeds the specified rpm range for your header.
10. Close the endshield. For instructions, refer to [Closing Header Endshields, page 42](#).

**Table 3.27 FD2 Series Header Knife Speed**

Header	Recommended Knife Drive Speed Range (rpm)	
	Single-Knife Drive	Double-Knife Drive
FD225	600–700	—
FD230	600–750	—
FD235	600–700	600–750
FD240	600–650	600–750
FD241	—	600–750
FD245	—	600–750
FD250	—	600–750

### 3.9.11 Reel Height

The reel operating position depends on the type of crop and the cutting conditions.

The reel height is controlled manually or with button presets on the ground speed lever (GSL) in the combine cab. Refer to your combine operator's manual or [Auto Header Height Control System, page 290](#) for more information.

For more information on reel fore-aft positioning, refer to [3.9.12 Reel Fore-Aft Position, page 252](#).

The following table describes how to change the reel position for different crop conditions:

**Table 3.28 Reel Position**

Crop Condition	Reel Position
Lodged rice	<ul style="list-style-type: none"> <li>• Lower the reel</li> <li>• Change the reel speed and/or the cam setting</li> <li>• Change the reel fore-aft position by extending the reel</li> </ul>
Bushy or heavy standing (all)	Raise the reel

If the reel is set too low, the following conditions may happen:

- Crop loss over the header backtube
- Crop disturbance on the drapers caused by the reel fingers
- Crop pushed down by the tine tubes
- Tall crop wrapped around the reel drive and ends

If the reel is set too high, the following conditions may happen:

- Cutterbar plugging
- Crop lodging and being left uncut
- Grain stalks dropping ahead of the cutterbar

For the recommended reel heights for specific crops and crop conditions, refer to [3.7.2 Header Settings, page 141](#).

#### **IMPORTANT:**

Maintain an adequate clearance between the reel and the cutterbar to prevent the reel fingers from contacting the cutterbar during operation. For instructions, refer to [4.13.1 Reel-to-Cutterbar Clearance, page 720](#).

## OPERATION

### *Checking and Adjusting Reel Height Sensor*

The orientation of the reel height sensor arm must be checked manually at the sensor. The output voltage range of the sensor can be checked either manually at the sensor or from the cab.

#### **IMPORTANT:**

Set the minimum reel height before adjusting the reel height sensor. For instructions, refer to and [Measuring Reel-to-Cutterbar Clearance, page 720](#).

#### **NOTE:**

For in-cab instructions, refer to the combine operator's manual.

#### **DANGER**

To prevent injury or death from the unexpected start-up of the machine, always stop the engine and remove the key from the ignition before leaving the operator's seat for any reason.

#### **DANGER**

Ensure that all bystanders have cleared the area.

#### *Checking and adjusting sensor arm orientation*

1. Park the combine on a level surface.
2. Shut down the engine, and remove the key from the ignition.
3. On the right endsheet, locate reel height sensor (A). The sensor connects to the right reel arm.

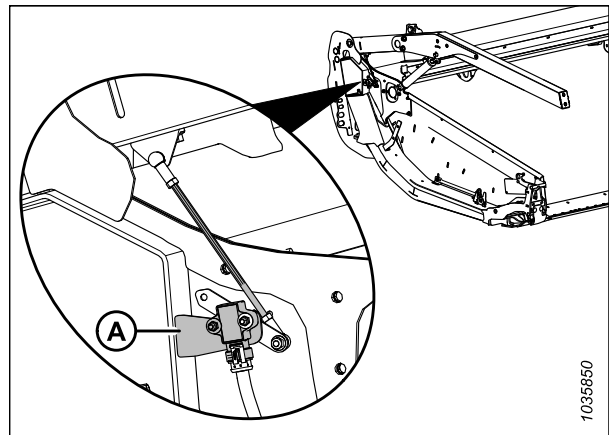
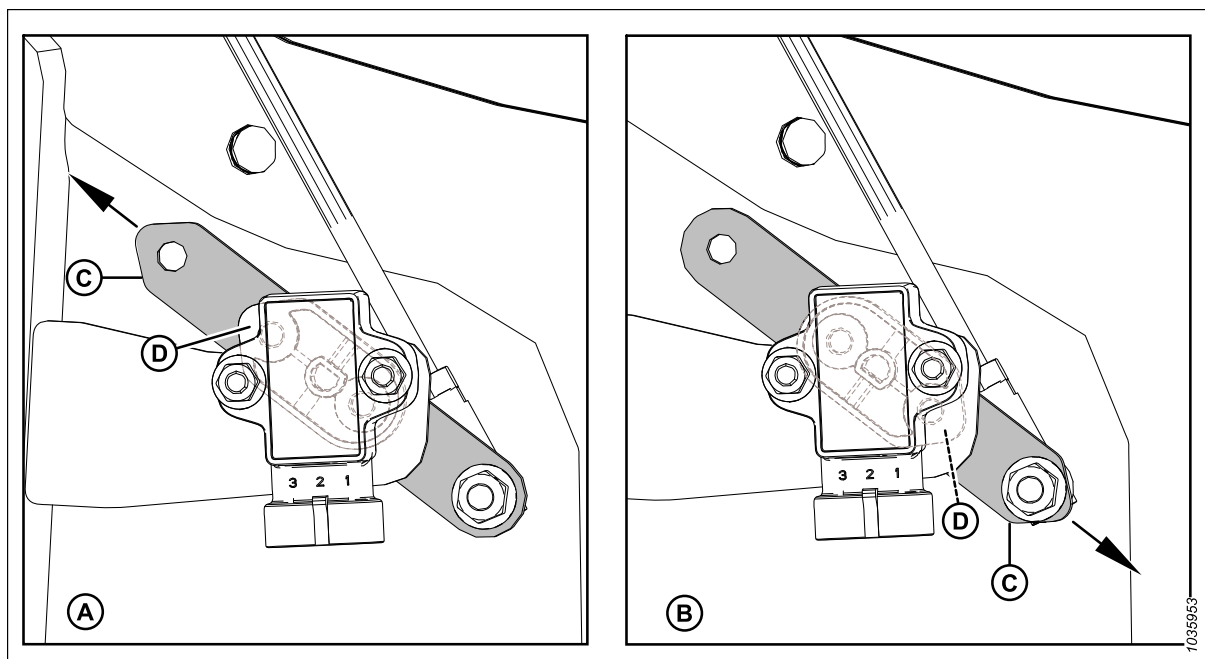


Figure 3.366: Reel Height Sensor Location

## OPERATION



**Figure 3.367: Sensor Arm/Pointer Configurations**

A - Challenger®, CLAAS, Gleaner®, IDEAL™, Massey Ferguson®, and John Deere Configuration

B - Case, New Holland, and Rostselmash Configuration

C - Sensor Arm

D - Sensor Pointer (Located Between Sensor and Sensor Arm)

- Ensure that sensor arm (C) and pointer (D) are configured properly for the header. For instructions, refer to Figure 3.367, page 249.

**NOTE:**

In configuration **A**, the arrow indicates that the pointed end of the sensor arm is pointed toward the back of the header.

In configuration **B**, the arrow indicates that the pointed end of the sensor arm is pointed toward the front of the header.

- If the sensor arm orientation is incorrect, remove sensor arm (C) and reposition it in the correct orientation. Torque the nut to 8.2 Nm (6 lbf·ft [72.5 lbf·in]).

**Checking and adjusting sensor output voltage when reel is lowered**

- Start the engine.
- Engage the parking brake.
- Lower the reel fully.
- Use the combine display or a voltmeter to measure the voltage range when the reel is lowered. Refer to Table 3.29, page 249 for the recommended voltage ranges.

**Table 3.29 Reel Height Sensor Voltage Limits**

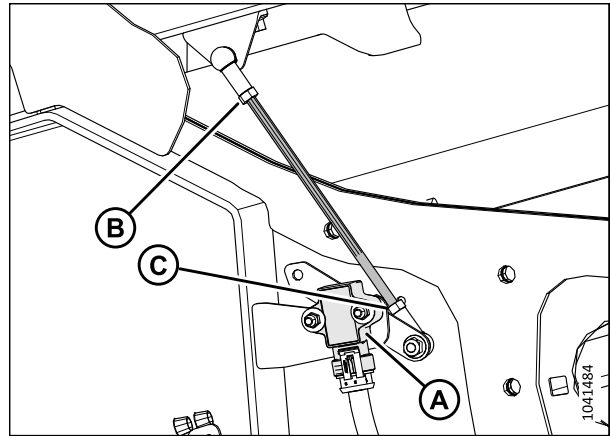
Combine Type	Recommended Voltage Range	
	Voltage with Reel Raised	Voltage with Reel Lowered
Case	0.7–1.1 V	3.9–4.3 V
Challenger®	3.9–4.3 V	0.7–1.1 V
CLAAS	3.9–4.3 V	0.7–1.1 V

## OPERATION

**Table 3.29 Reel Height Sensor Voltage Limits (continued)**

Combine Type	Recommended Voltage Range	
	Voltage with Reel Raised	Voltage with Reel Lowered
Gleaner®	3.9–4.3 V	0.7–1.1 V
IDEAL™	3.9–4.3 V	0.7–1.1 V
John Deere	3.9–4.3 V	0.7–1.1 V
Massey Ferguson®	3.9–4.3 V	0.7–1.1 V
New Holland	0.7–1.1 V	3.9–4.3 V
Rostselmash	0.7–1.1 V	3.9–4.3 V

10. Shut down the engine, and remove the key from the ignition.
11. Using a voltmeter, measure the voltage between the ground (pin 2 wire) and the signal (pin 3 wire) at reel height sensor (A).
12. Ensure that the voltage is within the recommended voltage range. If the voltage is not within the recommended range, loosen jam nuts (B) and (C), and adjust the rod length.
13. Tighten the jam nuts by hand until they are snug, then tighten the jam nuts by another quarter-turn.



**Figure 3.368: Reel Height Sensor – Right Reel Arm with Reel Down**

***Checking and adjusting sensor output voltage when reel is raised***

14. Start the engine.
15. Fully raise the reel.
16. Use the combine display or a voltmeter to measure the voltage range when the reel is raised. Refer to Table 3.29, page 249 for the recommended voltage ranges.
17. Shut down the engine, and remove the key from the ignition.

## OPERATION

18. Using a voltmeter, measure the voltage between the ground (pin 2 wire) and the signal (pin 3 wire) at reel height sensor (A).
19. If the voltage is not within the recommended range, loosen two M5 hex nuts (B) and rotate sensor (A) to achieve the recommended voltage range.
20. Tighten nuts (B) to 2.5 Nm (1.8 lbf-ft [22 lbf-in]).
21. Lower the reel fully.

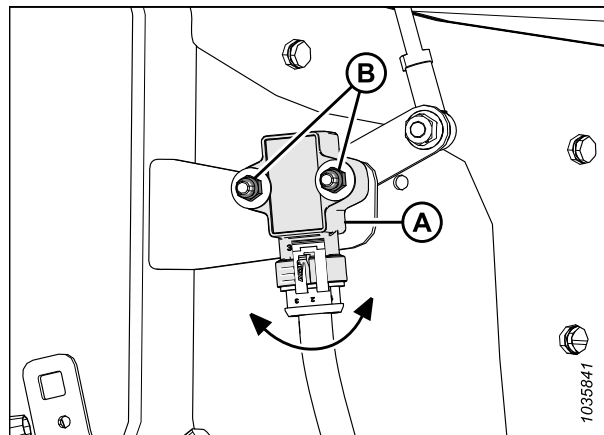


Figure 3.369: Reel Height Sensor – Right Reel Arm with Reel Up

### Replacing Reel Height Sensor

The reel height sensor is used to reference where the reel is positioned above from the cutterbar.

#### DANGER

Ensure that all bystanders have cleared the area.

#### DANGER

To prevent bodily injury or death from the unexpected start-up of the machine, always stop the engine and remove the key from the ignition before making adjustments to the machine.

1. Lower the reel fully.
2. Shut down the engine, and remove the key from the ignition.
3. Disconnect the harness from sensor (A).
4. Remove two hex head bolts (B) from sensor arm (C). Retain the hardware for reinstallation.

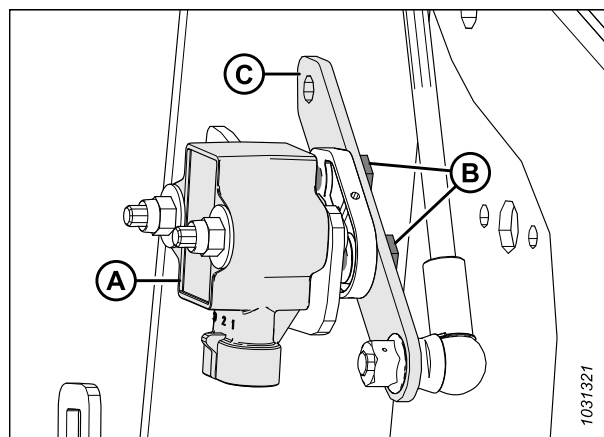


Figure 3.370: Reel Height Sensor – Right Reel Arm

## OPERATION

5. Remove two nyloc nuts, washers, and bolts (A) securing sensor (B) to the header frame. Remove the sensor.
6. Install new sensor (B) onto bracket (C) on the header frame.
7. Attach the sensor using retained bolts (A), washers, and nyloc nuts.
8. Torque bolts (A) to 2–3 Nm (1.5–2.2 lbf-ft [17–27 lbf-in]).

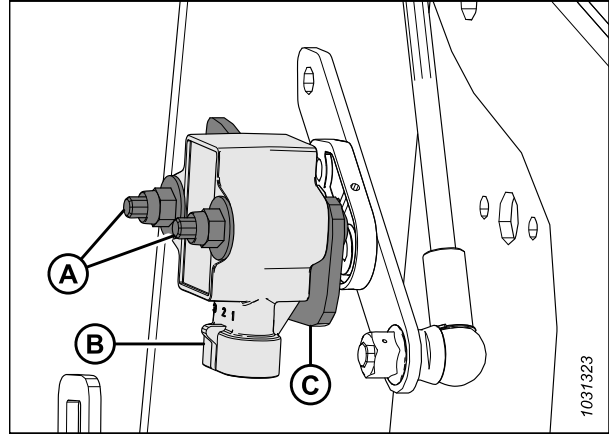


Figure 3.371: Reel Height Sensor – Right Reel Arm

9. Secure sensor arm (B) using retained hex head bolts (A). Ensure that sensor pointer (C) is installed in the same direction as the pointed end of sensor arm (B).
10. Torque bolts (A) to 4 Nm (2.95 lbf-ft [35 lbf-in]).
11. Connect the harness to the sensor.
12. Check the sensor voltage range. For instructions, refer to [Checking and Adjusting Reel Height Sensor, page 248](#).

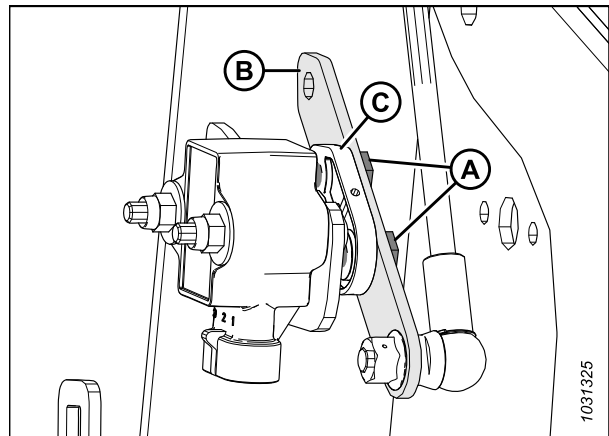


Figure 3.372: Reel Height Sensor – Right Reel Arm

### 3.9.12 Reel Fore-Aft Position

The reel fore-aft position is a critical factor for achieving the best results in adverse conditions. The factory-recommended reel position has the position marker centered over numbers (4–5 on the indicator). This position suits normal conditions, but you can adjust the fore-aft position as required.

To improve the reel's performance in certain crop conditions, the reel can be moved approximately 155 mm (6 in.) farther aft by repositioning the fore-aft cylinders on the header's reel arms. For instructions, refer to [Repositioning Fore-Aft Cylinders, page 253](#).



## OPERATION

The reel position indicator (A) is located at the left reel arm. Bracket (B) is the reel fore-aft position marker.

For straight standing crop, center the reel over the cutterbar (4–5 on indicator).

For crops that are down, tangled, or leaning, it may be necessary to move the reel ahead of the cutterbar (the lower number on the indicator).

### NOTE:

If you are having difficulty picking up flattened crop, adjust the header to a steeper angle. For instructions, refer to [3.9.5 Header Angle, page 232](#). Only adjust the reel position after adjusting the header angle.

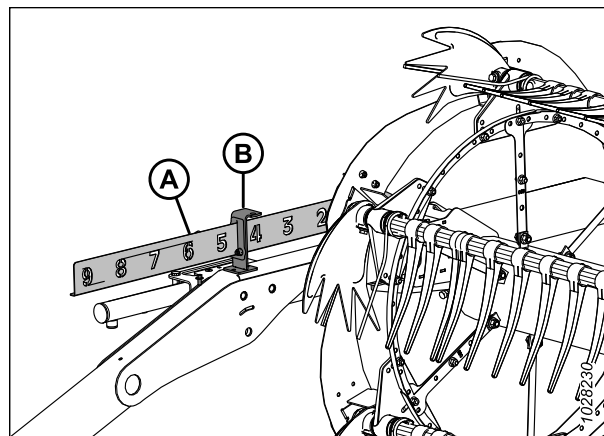


Figure 3.373: Fore-Aft Indicator

### NOTE:

In crops that are difficult to pick up such as rice, or in severely lodged crops that require full forward positioning of the reel, set the reel tine pitch to properly place the crop onto the drapers. For instructions, refer to [3.9.13 Reel Tine Pitch, page 261](#).

### Adjusting Reel Fore-Aft Position

The factory-set reel position suits normal conditions, but you can adjust the fore-aft position as required by using the controls inside of the cab.

To adjust the reel fore-aft position, follow these steps:

1. Operate the hydraulics to move the reel to the desired position while using fore-aft indicator (A) as a reference. Bracket (B) is the position marker.
2. Check the reel to cutterbar clearance after adjusting the cam setting. Refer to the following:
  - [4.13.1 Reel-to-Cutterbar Clearance, page 720](#)
  - [4.13.2 Reel Frown, page 727](#)

### IMPORTANT:

Operating with the reel too far forward can result in the fingers contacting the ground. When operating with the reel in this position, lower the skid shoes or adjust the header tilt as required to prevent damaging the fingers.

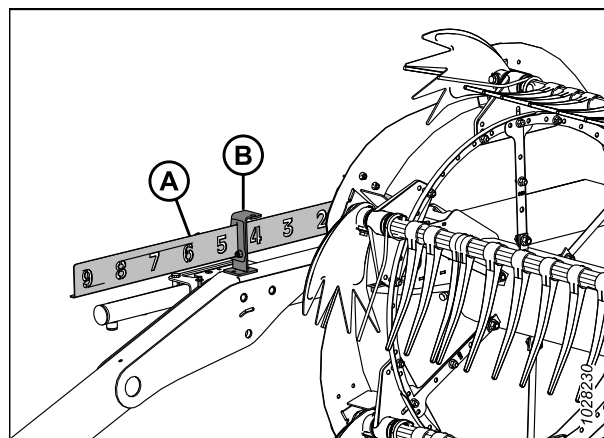


Figure 3.374: Fore-Aft Indicator

### Repositioning Fore-Aft Cylinders

To accommodate certain crop conditions, you can move the reel approximately 155 mm (6 in.) farther aft by repositioning the fore-aft cylinders on the reel arms.

## DANGER

Ensure that all bystanders have cleared the area.

## OPERATION

### DANGER

To prevent injury or death from the unexpected start-up of the machine, always stop the engine and remove the key from the ignition before leaving the operator's seat for any reason.

#### IMPORTANT:

Ensure that all of the fore-aft cylinders are set to the same position.

1. Adjust the reel height so that the reel arms are parallel with the ground.
2. Shut down the engine, and remove the key from the ignition.
3. Remove hairpin (A) securing the multi-tool to the bracket on the left endsheet.
4. Remove multi-tool (B). Reinstall the hairpin.

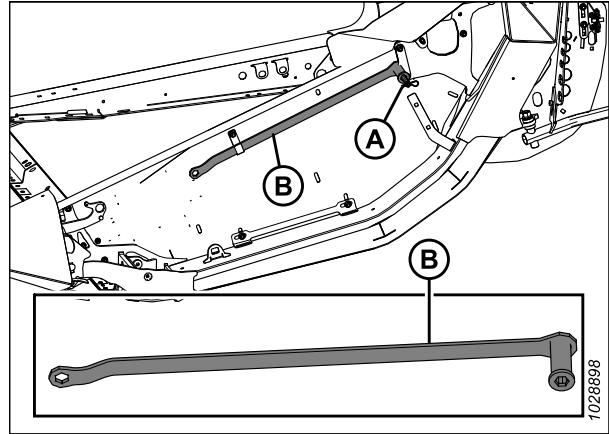


Figure 3.375: Left Endsheets

## OPERATION

5. Refer to Figure 3.376, page 255 to determine the fore-aft cylinder adjustment procedures for your header type. The number on the illustration refers to one of the following procedures:
- For reel arms with fore-aft cylinder adjustment [1] at the front, refer to Step 1, page 256.
  - For reel arms with fore-aft cylinder adjustment [2] at the rear, refer to Step 1, page 257.

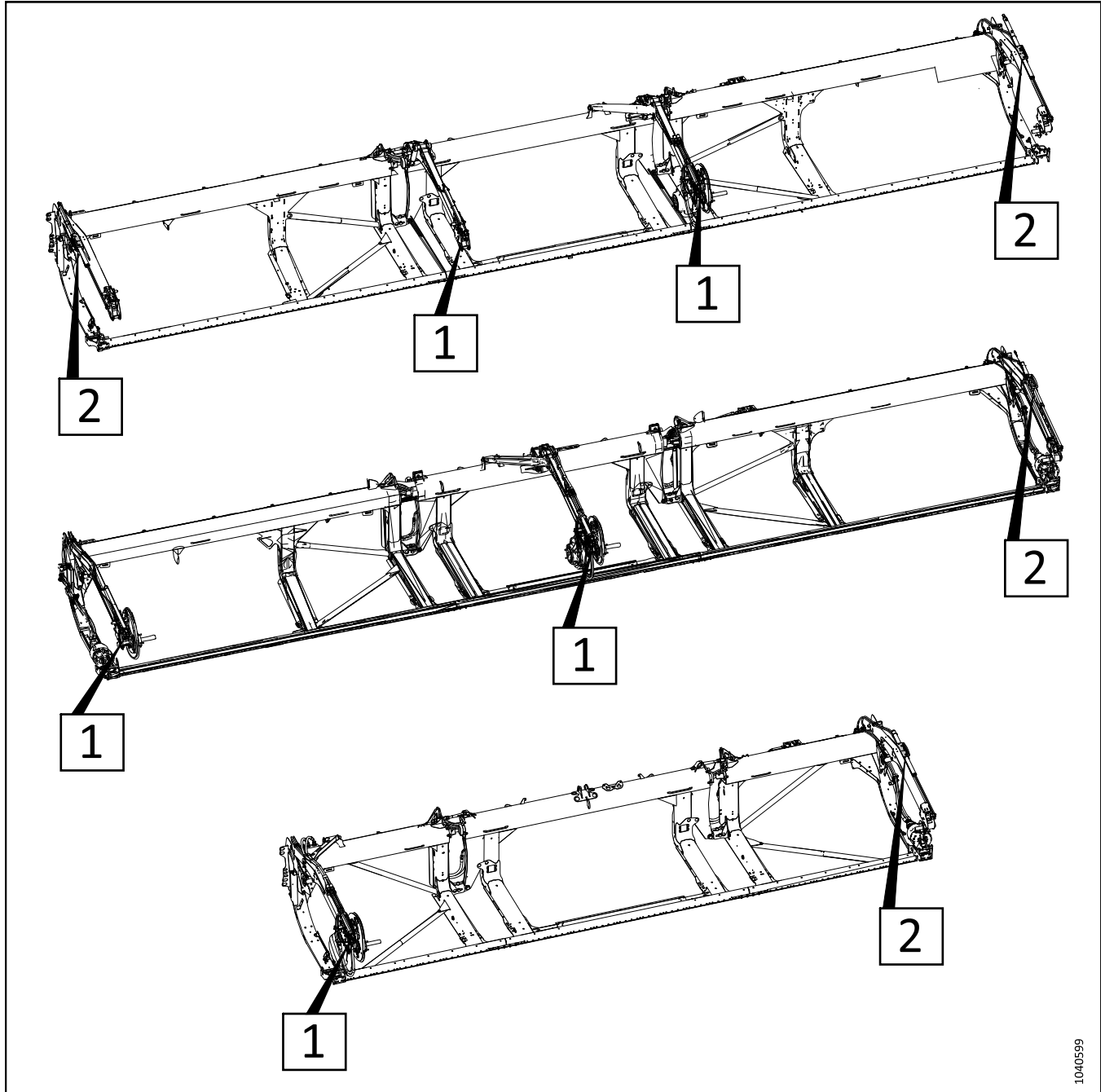


Figure 3.376: Adjustable Fore-Aft Cylinders – Procedure Reference Numbers

1040599

## OPERATION

To change the reel position on the fore-aft cylinders that adjust at the front of the reel arm, follow these steps:

1. Remove split ring (A), clevis pin (B), and flat washer (not shown) securing the adjustable fore-aft cylinder in the forward position.

**NOTE:**

The reel drive components are not shown in the illustration.

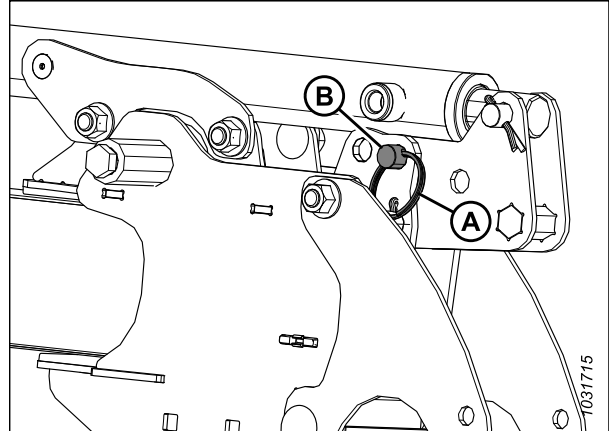


Figure 3.377: Fore-Aft Cylinder Adjustment Type 1 – Forward Position

2. Use multi-tool (A) to push bracket (B) rearward until hole (C) aligns with hole (D). The reel will move rearward as bracket (B) rotates on bottom pin (E).

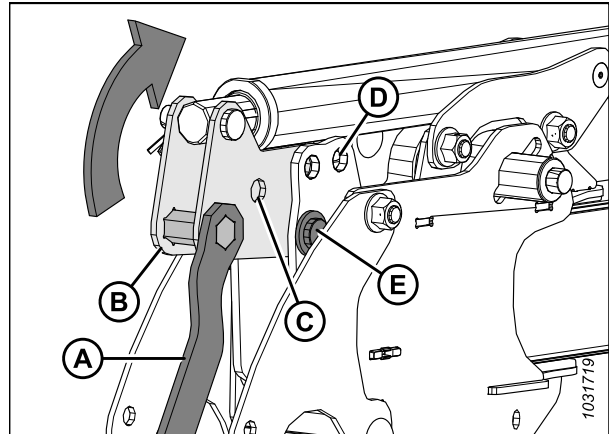


Figure 3.378: Fore-Aft Cylinder Adjustment Type 1 – Forward Position

3. Secure the cylinder in the aft position with clevis pin (A), flat washer, and split ring (B).

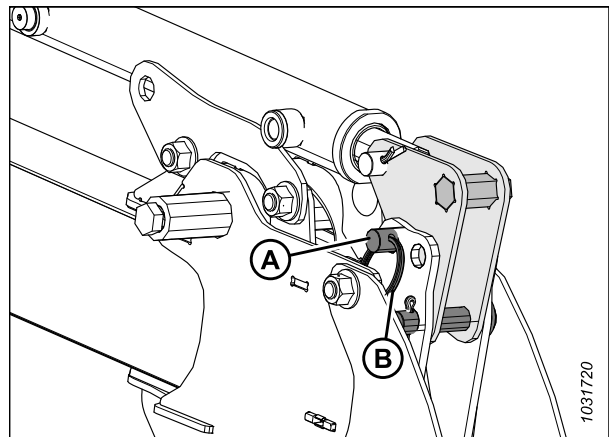


Figure 3.379: Fore-Aft Cylinder Adjustment Type 1 – Aft Position

## OPERATION

To change the reel position on the fore-aft cylinders that adjust at the back of the reel arm, follow these steps:

### NOTE:

The slotted cylinder bracket shown in the following illustrations is mounted on the outboard side of the reel arm.

1. Remove split ring (A) and clevis pin (B) securing the left cylinder in the forward position on cylinder bracket (C).

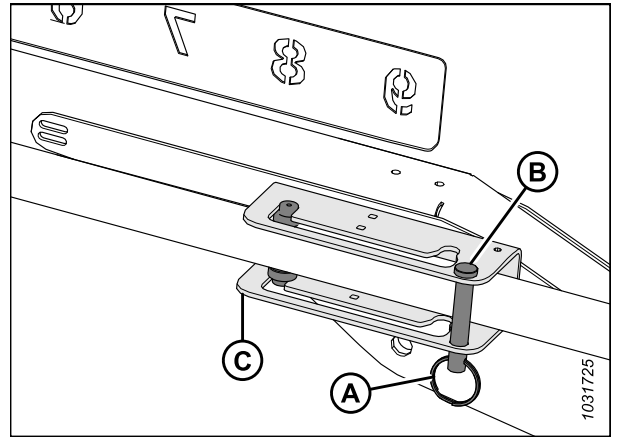


Figure 3.380: Fore-Aft Cylinder Adjustment Type 2 – Forward Position

2. Slide cylinder guides (A) along the bracket slot and into aft position (B).

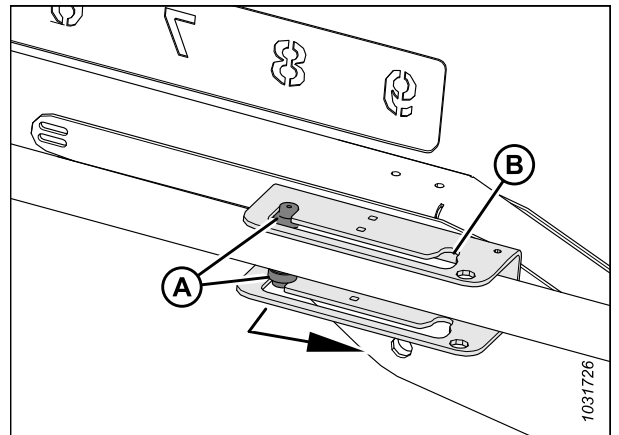


Figure 3.381: Fore-Aft Cylinder Adjustment Type 2 – Forward Position

3. Reinstall clevis pin (A) and split ring (B) to secure the cylinder in aft position (C) on the bracket.

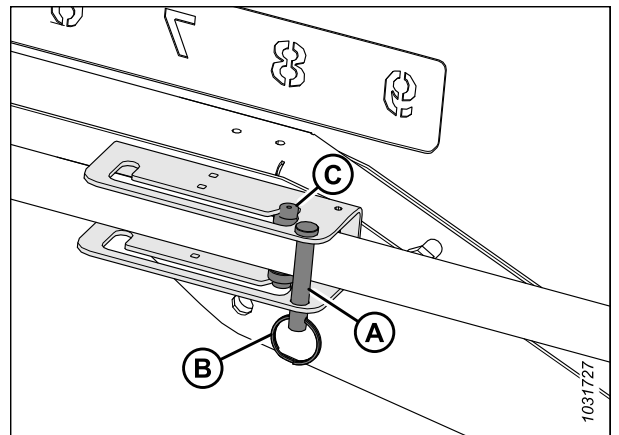


Figure 3.382: Fore-Aft Cylinder Adjustment Type 2 – Aft Position

## OPERATION

4. Ensure that there is still an adequate clearance between the reel and the following parts of the header:
  - Backsheet
  - Reel braces
  - Upper cross auger (if this is installed on the header)
5. If necessary, adjust the reel tine pitch. For instructions, refer to [3.9.13 Reel Tine Pitch, page 261](#).

### Checking and Adjusting Fore-Aft Position Sensor Voltage

The fore-aft position sensor indicates the position of the reel in the fore-aft plane. The sensor arm's orientation needs to be set for the correct model.

#### DANGER

To prevent injury or death from the unexpected start-up of the machine, always stop the engine and remove the key from the ignition before leaving the operator's seat for any reason.

#### DANGER

Ensure that all bystanders have cleared the area.

1. Verify that the reel fore-aft sensor is oriented correctly for the model of combine before checking the voltage. For instructions, refer to [Checking and Adjusting Fore-Aft Position Sensor Orientation, page 259](#).
2. Park the combine on a level surface.
3. Adjust the reel fully rearward.
4. Use the combine display or a voltmeter (if measuring the sensor manually) to measure the voltage range. If you are using a voltmeter, check sensor voltage (A) between pin 2 (ground) and pin 3 (signal). For the voltage range, refer to [Table 3.30, page 258](#).

#### IMPORTANT:

To measure the output voltage of the fore-aft sensor, the engine needs to be running and supplying power to the sensor.

5. Adjust the reel fully forward.
6. Check the voltage. If the sensor needs adjustment, refer to [Step 7, page 259](#) to [Step 11, page 259](#)

**Table 3.30 Fore-Aft Sensor Voltage**

Combine	Voltage (V) – Reel Fully Retracted	Voltage (V) – Reel Fully Extended	Minimum Range (V)
Case, New Holland, and Rostselmash	0.7	4.3	2.5
Challenger®, CLAAS, Gleaner®, IDEAL®, John Deere, and Massey Ferguson®	4.3	0.7	2.5

## OPERATION

7. Shut down the engine, and remove the key from the ignition.
8. Locate fore-aft position sensor on the left reel arm.

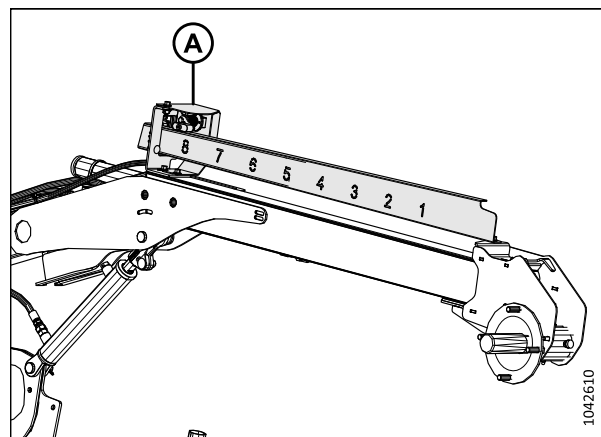


Figure 3.383: Fore-Aft Position Sensor

9. Loosen hardware (B) and move sensor support (C) until the voltage is in the correct range.
10. Once sensor adjustment is complete, torque the hardware to 8 Nm (71 lbf-in).
11. If required, run the combine fore-aft sensor calibration.

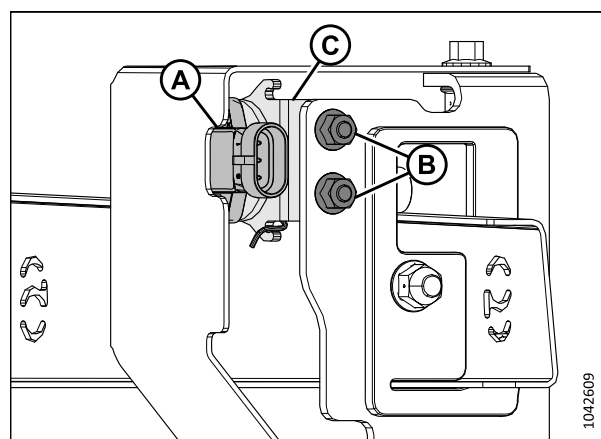


Figure 3.384: Fore-Aft Sensor

### *Checking and Adjusting Fore-Aft Position Sensor Orientation*

The fore-aft position sensor indicates the position of the reel in the fore-aft plane. The sensor arm's orientation needs to be set for the correct model.

#### **DANGER**

To prevent injury or death from the unexpected start-up of the machine, always stop the engine and remove the key from the ignition before leaving the operator's seat for any reason.

#### **DANGER**

Ensure that all bystanders have cleared the area.

1. Park the combine on a level surface.
2. Shut down the engine, and remove the key from the ignition.

## OPERATION

3. Locate fore-aft position sensor on the left reel arm.

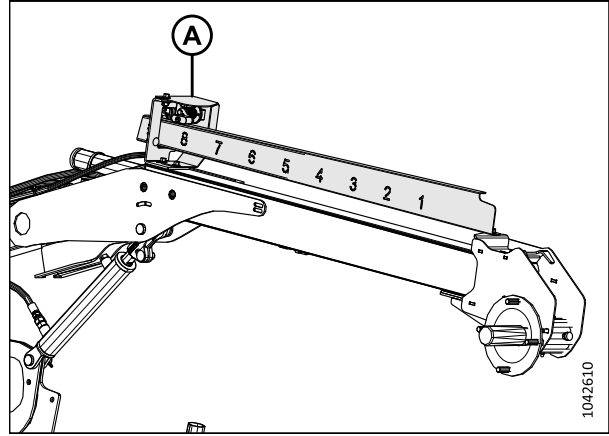
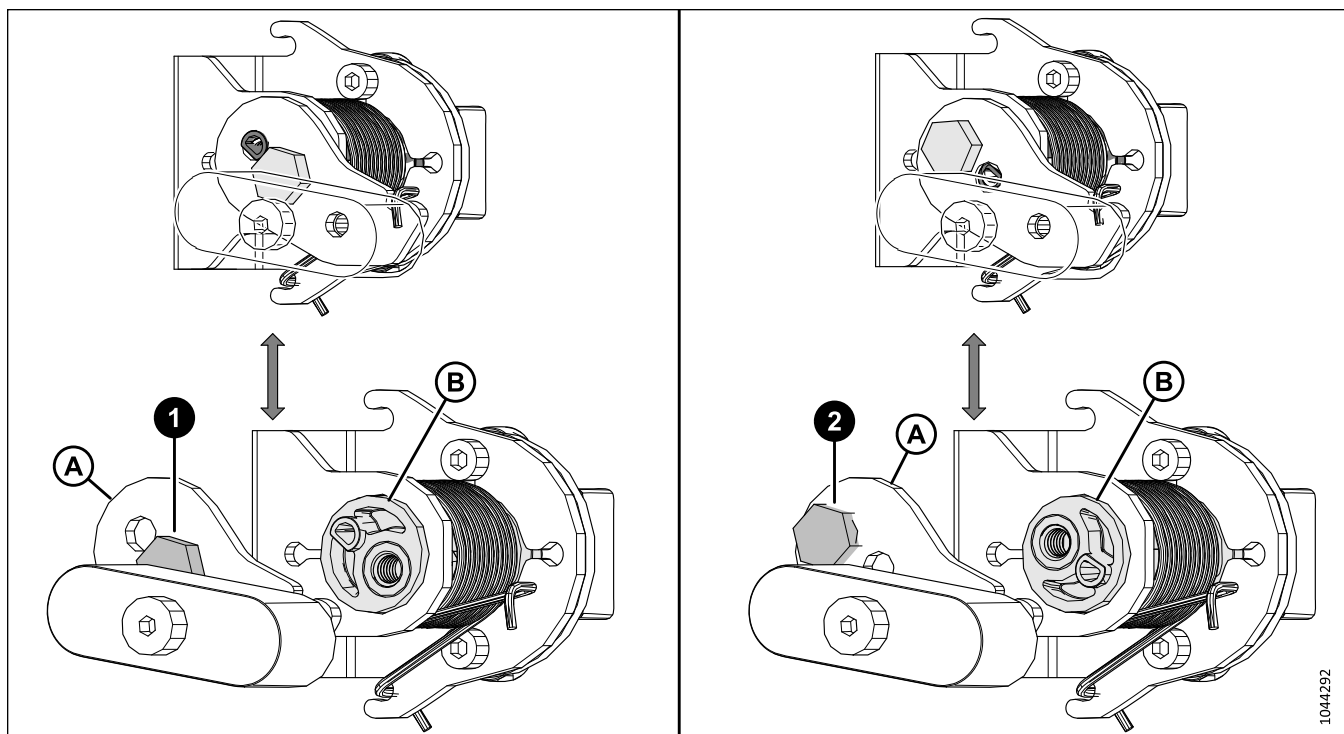


Figure 3.385: Fore-Aft Position Sensor





**Figure 3.386: Sensor Arm Position**

4. Check the installation location of sensor mounting bolt :
  - Location (1) is used for Case, New Holland, and Rostselmash.
  - Location (2) is used for Challenger®, CLAAS, Gleaner®, IDEAL™, Massey Ferguson®, and John Deere
 If the bolt is in the incorrect location, proceed to the next step.
5. Remove the bolt and move it to the correct location on arm (A).
6. Rotate sensor pivot (B) 180°.
7. Reinstall arm (A) onto the sensor pivot. Ensure the raised bump is in the other hole where the bolt was removed from.
8. Tighten the bolt to 6 Nm (4 lbf-ft [53 lbf-in]).

### 3.9.13 Reel Tine Pitch

Reel tine pitch describes the position of the reel fingers in relation to the cutterbar. You can change it by changing the reel fore-aft position and the reel cam setting. You may also wish to change the reel tine pitch to suit different harvesting conditions.

Changing the reel position has the largest impact on the reel tine pitch. On the other hand, changing the cam setting has a smaller impact on the reel tine pitch. For example, with the cam position range at 33°, the corresponding finger pitch range is only 5° at the lowest point of the reel's rotation.

For the best results, use the minimum cam setting that delivers the crop past the rear edge of the cutterbar and onto the drapers. For more information, refer to [3.7.2 Header Settings, page 141](#).

#### *Reel Cam Settings*

Changing the cam position allows you to adjust the point at which the reel fingers release gathered crop to the drapers. Recommendations are provided for reel cam settings in various harvesting conditions.

The setting numbers are visible above the slots on the cam disc. For instructions, refer to [Adjusting Reel Cam, page 263](#).

## OPERATION

### NOTE:

For the recommended reel tine pitch setting to use in various harvesting conditions, refer to [3.7.2 Header Settings, page 141](#).

**Cam Position 1, Reel Position 5 or 6** delivers the most even crop flow onto the drapers without fluffing or disturbing the material.

- This setting will release crop close to the cutterbar. Use this setting when the cutterbar is on the ground while harvesting.
- Some crops will not be delivered past the cutterbar when the cutterbar is raised off the ground while the reel is far forward. Therefore, set the initial reel speed so that it is close to the ground speed.

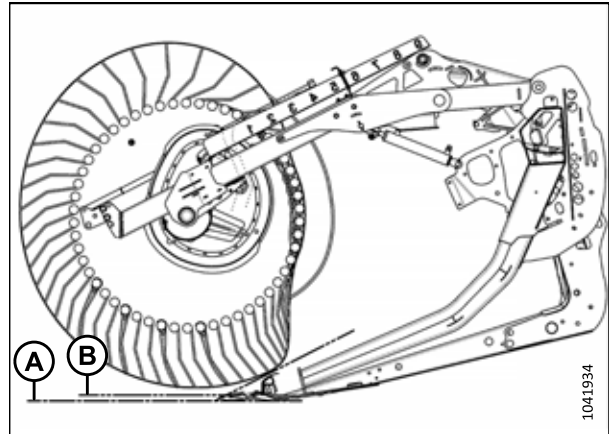


Figure 3.387: Finger Profile – Cam Position 1

**Cam Position 2, Reel Position 6 or 7** is the recommended starting position for most crops and conditions.

- Before adjusting the cam setting, adjust the reel fore or aft to try to bring the crop onto the draper.
- If the crop is still stalling on the cutterbar and the reel cannot push the crop back on the draper, increase the cam setting to push the crop past the rear edge of the cutterbar.
- If the crop is fluffing or if there is a disruption to the flow across the drapers, decrease the cam setting.
- This setting results in the reel fingertip speed being approximately 20% faster than the reel speed.

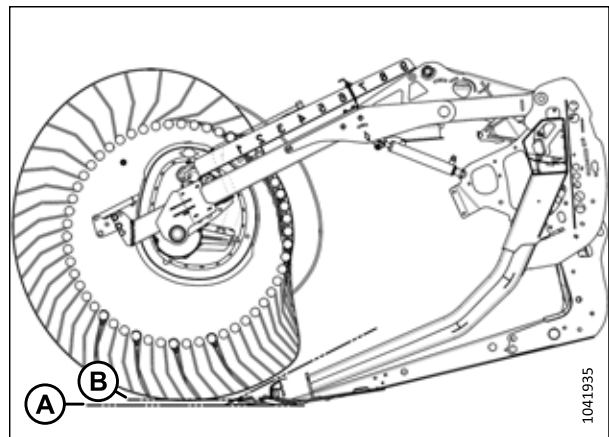


Figure 3.388: Finger Profile – Cam Position 2

**Cam Position 3, Reel Position 8** is mainly used to leave long stubble.

- This position allows the reel to reach forward and lift the crop across the knife and onto the drapers.
- This setting results in the reel fingertip speed being approximately 30% faster than the reel speed.

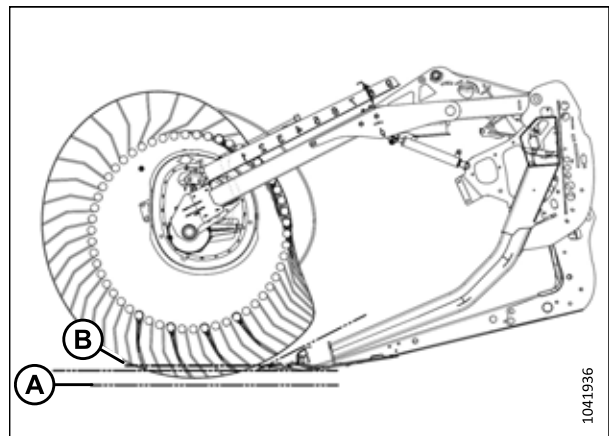


Figure 3.389: Finger Profile – Cam Position 3

## OPERATION

**Cam Position 4, Header Angle at Minimum, Reel Position 9** results in the header leaving a shorter stubble when harvesting lodged crops (in comparison to a header that is tilted fully forward). With this header angle, the reel just manages to graze the ground.

- This position allows the reel to reach forward and lift the crop across the knife and onto the drapers.
- This setting results in the reel fingertip speed being approximately 35% faster than the reel speed.

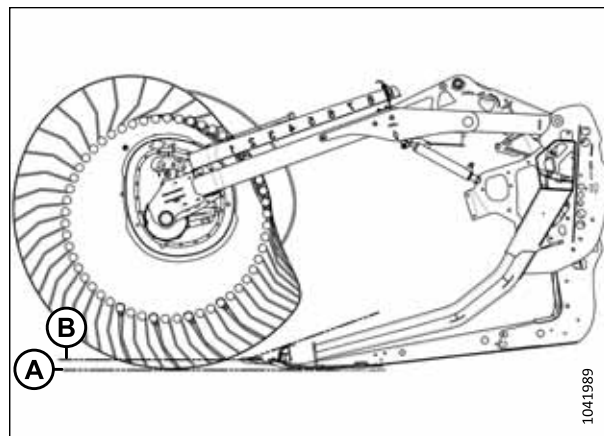


Figure 3.390: Finger Profile – Cam Position 4, Minimum Header Angle

**Cam Position 4, Header Angle at Maximum, Reel Position 9** provides the maximum amount of reel reach below the cutterbar to pick up lodged crops.

- This position leaves a significant amount of stubble when the cutting height is set to approximately 203 mm (8 in.). In damp materials such as rice, it is possible to double the combine's ground speed because of the reduction of cut material.
- This setting results in the reel fingertip speed being approximately 35% faster than the reel speed.

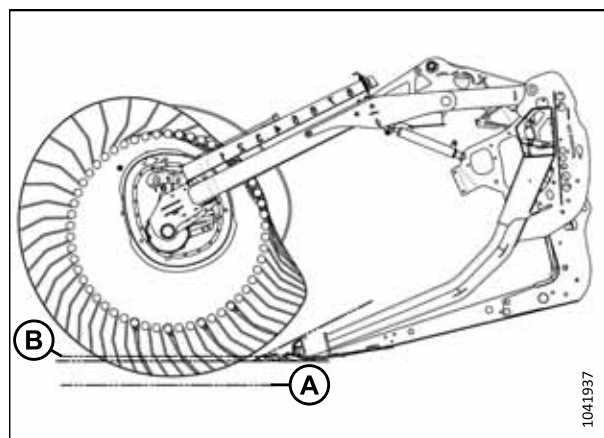


Figure 3.391: Finger Profile – Cam Position 4, Maximum Header Angle

### NOTE:

Using higher cam settings when the reel's fore-aft position is set between 4 and 5 results in drastically decreased draper capacity. This happens because the reel fingers continually engage with crop that is already moving on the drapers, disrupting flow into the combine feeder house. Higher cam settings are recommended only when the reel is at or close to the fully forward setting.

### Adjusting Reel Cam

Adjust the reel cam to change the reel tine pitch.

### IMPORTANT:

Always check the reel-to-cutterbar clearance after adjusting the reel tine pitch and the reel fore-aft position. For more information, refer to [4.13.1 Reel-to-Cutterbar Clearance, page 720](#) and [3.7.2 Header Settings, page 141](#).

### DANGER

To prevent injury or death from the unexpected start-up of the machine, always stop the engine and remove the key from the ignition before leaving the operator's seat for any reason.

### NOTE:

If there are multiple reel cams, adjust all of them.

## OPERATION

1. Shut down the engine, and remove the key from the ignition.
2. Remove hairpin (A) securing multi-tool (B) to the bracket on the left endsheet.

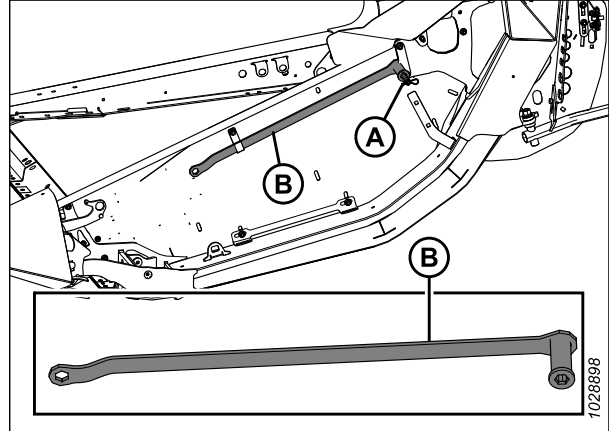


Figure 3.392: Left Endsheet

3. Using the multi-tool, turn latch pin (A) **COUNTERCLOCKWISE** to release the cam disc.

**IMPORTANT:**

Refer to the cam latch decal for the locking/unlocking rotation direction. Forcing the cam latch in the wrong direction can damage the roll pins.

4. Use the multi-tool on bolt (B) to rotate the cam disc and align latch pin (A) with the desired cam disc hole position (C) (1 to 4).

**NOTE:**

Bolt (B) is welded to the cam support.

5. Turn latch pin (A) **CLOCKWISE** to engage and lock the cam disc.

**IMPORTANT:**

Ensure that the cam is secured into position before operating the machine.

6. Repeat Step 3, [page 264](#) to Step 5, [page 264](#) for all of the reel cams.

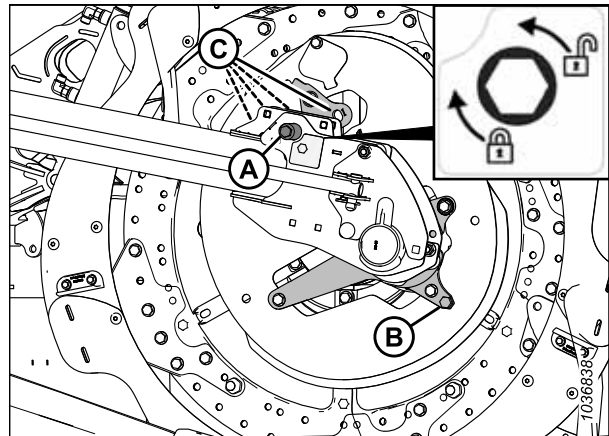


Figure 3.393: Cam Disc Positions

## OPERATION

### 3.9.14 Upper Cross Auger

The upper cross auger (UCA) improves crop feeding into the center of the header in heavy crop conditions. It is ideal for high-volume harvesting of forages, oats, canola, mustard, and other tall, bushy, hard-to-convey crops.

You can use shutoff valve (A) to turn off the UCA when it is not needed.

**NOTE:**

Even if the UCA is shut off, it still needs to be greased at regular intervals because of the movement of the wings.

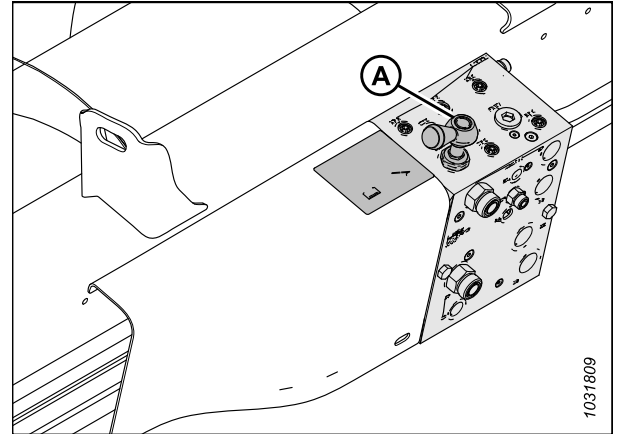


Figure 3.394: Shutoff Valve

#### *Adjusting Upper Cross Auger Position – Two or Three Piece Augers*

The upper cross auger (UCA) has an adjustable mount that allows you to adjust the position for different harvesting conditions. Headers with three-piece augers have two adjustable mounts: one on each end of the center auger.

**NOTE:**

For more information on the positions of the primary and secondary front bolts, refer to [Figure 3.397, page 266](#).

## OPERATION

The mount(s) are initially installed in the rear-most position, so that front bolt (A) is in the primary position. This position is the recommended configuration for most conditions.

When front bolt (A) is in the primary position, the auger and the reel are safe to operate in any position. You can adjust the position of the auger to a limited extent by changing the position of the mount with respect to rear bolt (B).

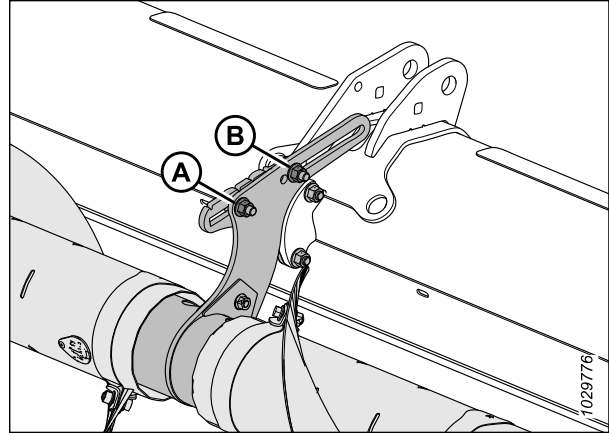


Figure 3.395: Initial Position of Adjustable Mounts – Two-Piece Auger

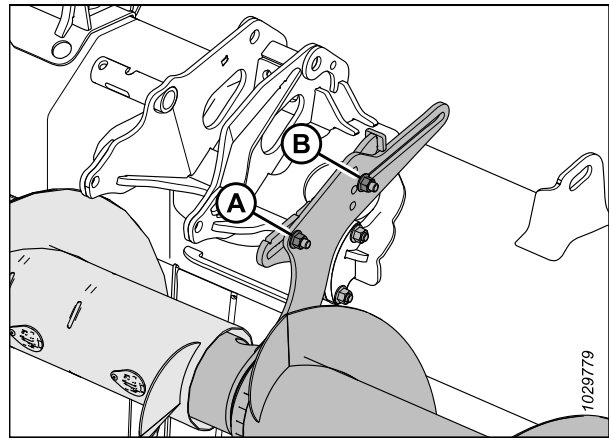


Figure 3.396: Initial Position of Adjustable Mounts – Three-Piece Auger

The auger position can be adjusted to a greater extent by moving the front bolt to secondary position (B). For three-piece augers (2), additional secondary positions (B) are available if you wish to raise or lower the auger. When the front bolt is in one of these positions, the fore-aft adjustment is limited, which prevents the UCA from interfering with the feed auger and the header frame.

### IMPORTANT:

When the front bolt is in one of secondary positions (B) and the reel is in its rear-most position, the reel fingers and the cam arms may contact the UCA. When the reel is moved fully back (for example, when harvesting canola), the UCA must also be moved fully back in order to allow for a sufficient clearance between the reel fingers and the auger.

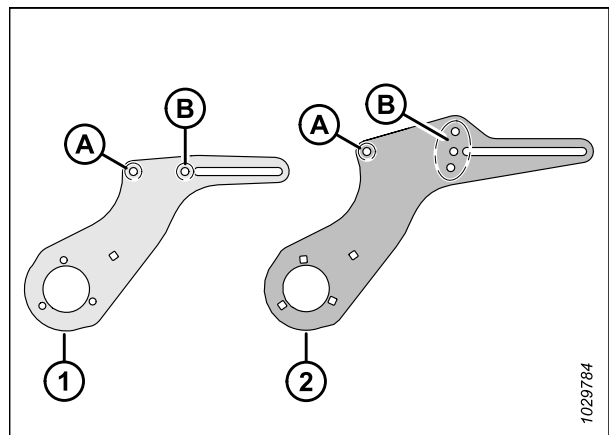


Figure 3.397: Adjustable Mount Details

1 - Two-Piece Auger Mount

2 - Three-Piece Auger Mount

A - Primary Position for Front Bolt

B - Secondary Position(s) for Front Bolt



## OPERATION

Move the auger forward to

- Help convey light crops, especially on side hills
- Improve the feeding of light crops
- Reduce the reel carry over or reduce the crop flow disruption caused by the reel

Move the auger rearward to

- Increase the available volume for conveying heavy crop
- Keep the auger close to the deflectors to prevent crop from getting behind the auger and wrapping around the auger

To adjust the auger position, do the following:

1. Locate the adjustable mount.

**NOTE:**

On two-piece augers, the adjustable mount protrudes from the center support assembly. On three-piece augers, the adjustable mount protrudes from the ends of the center auger.

**NOTE:**

The illustration shows the left adjustable mount on a three-piece auger. The adjustable mount on a two-piece auger is similar, but has only one secondary position for the front bolt instead of three. Refer to Figure 3.397, page 266 for more information.

2. If desired, relocate front bolt and nut (A). The front bolt and nut have two possible locations on two-piece augers: the primary location and the secondary location. On three-piece augers, there are four possible locations: one primary location and three secondary locations.
3. Loosen front nut (A) and rear nut (B) just enough to allow the adjustable mount to slide.
4. Move the mount to the desired position.
5. Retighten nuts (A) and (B). Torque the nuts to 69 Nm (51 lbf-ft).

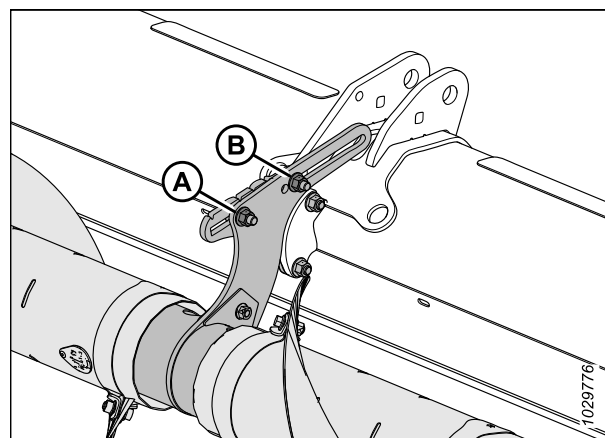


Figure 3.398: Initial Position of Adjustable Mounts – Two-Piece Auger

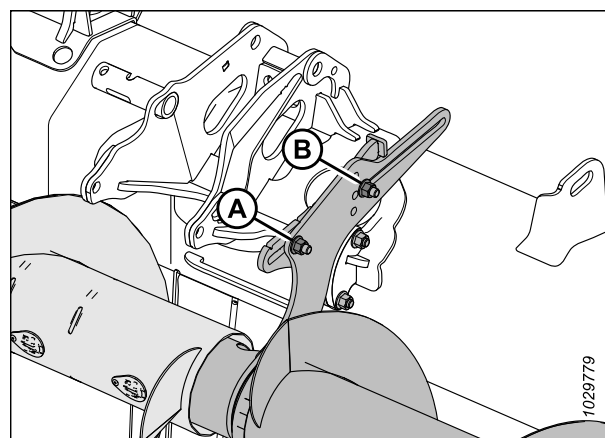


Figure 3.399: Initial Position of Adjustable Mounts – Three-Piece Auger

6. If a three-piece UCA is installed, repeat Step 1, page 267 to Step 5, page 267 on the second adjustable mount.

**IMPORTANT:**

On headers with three-piece augers, ensure that both of the mounts are in the same position.

7. Check for any interference between the reel fingers and the UCA. Check for interference between the cam arms and the UCA along the entire hydraulic fore-aft range of the reel. For instructions, refer to [Checking Upper Cross Auger for Interference, page 268](#).

### Checking Upper Cross Auger for Interference

If the upper cross auger (UCA) is out of adjustment, it can contact the reel or the header frame. The clearance between the UCA and certain header components will need to be inspected.

#### DANGER

To prevent injury or death from the unexpected startup of the machine, stop the engine and remove the key from the ignition before you make adjustments to the machine.

#### DANGER

Ensure that all bystanders have cleared the area.

1. Start the engine.
2. Adjust the reel fully rearward.
3. Place 254–356 mm (10–14 in.) blocks under the cutterbar at both ends of the header. Lower the header onto the blocks so that the header forms a smile shape.
4. Shut down the engine, and remove the key from the ignition.
5. Manually rotate UCA (A). Ensure that the clearance between the UCA and the header components is at least 10 mm (13/32 in.) at the following locations:
  - Reel cam arms (B)
  - Reel fingers (C)
  - Reel cylinder supports (D)
  - Split-frame headers: Split frame joint (E)
  - FD241, FD245, and FD250: Split frame joint (E)
6. If the clearance between the UCA and the header components requires adjustment, proceed to [Adjusting Upper Cross Auger Position – Two or Three Piece Augers](#), page 265.

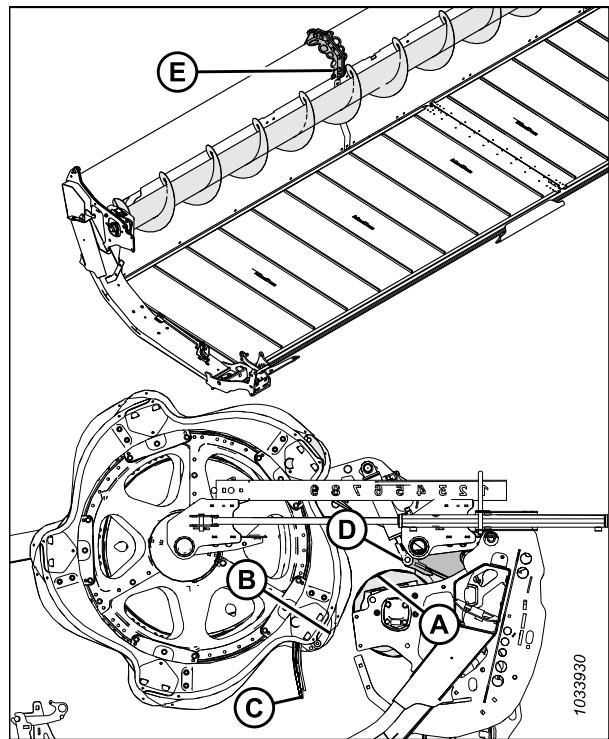


Figure 3.400: UCA Clearance Check Locations

### 3.9.15 Crop Dividers

Crop dividers separate the crop when harvesting. Remove them to install vertical knives and to decrease transport width.

Standard crop dividers are provided with all headers. You may also purchase optional floating crop dividers. Refer to [5.1.4 Floating Crop Dividers](#), page 788.



## OPERATION

### Removing Crop Dividers

Crop dividers can be removed to allow the installation of other options or to decrease the transport width.

#### DANGER

To prevent bodily injury or death from the unexpected start-up or fall of a raised machine, always stop the engine, remove the key, and engage the safety props before going under the header for any reason.

#### DANGER

Ensure that all bystanders have cleared the area.

1. Start the engine.
2. Lower the reel and raise the header. For instructions, refer to the combine operator's manual.
3. Shut down the engine, and remove the key from the ignition.
4. Engage the safety props. For instructions, refer to the combine operator's manual.
5. Open the endshields. For instructions, refer to *Opening Header Endshields, page 41*.
6. Remove lynch pin (A).
7. Hold onto crop divider (E).
8. Rotate hex shaft (B) on divider latch (C) forward to disengage it from bolt (D).

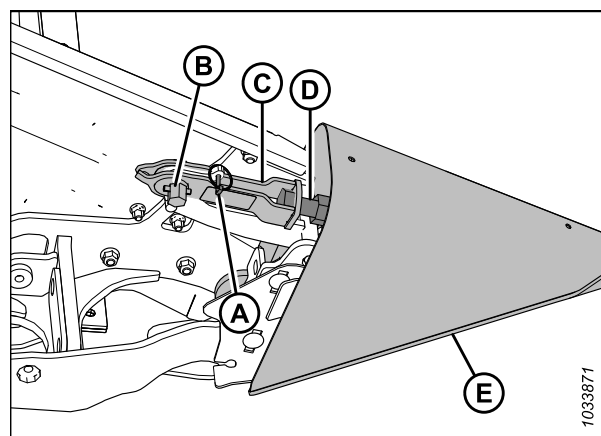


Figure 3.401: Crop Divider with Latch

9. Lower crop divider (A) and remove it from the endsheet.
10. Close the endshield. For instructions, refer to *Closing Header Endshields, page 42*.

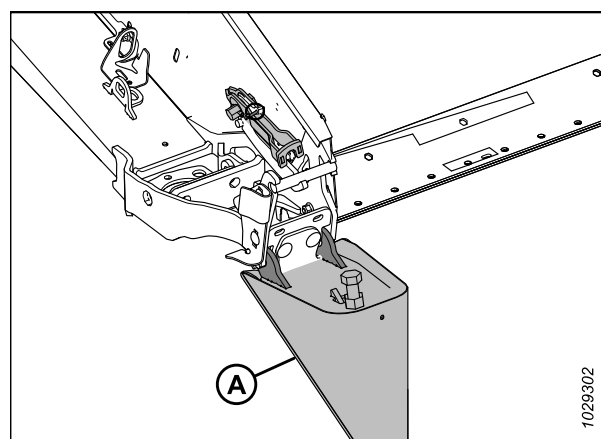


Figure 3.402: Crop Divider with Latch

## OPERATION

11. If the optional storage bracket is installed, put crop divider (A) in position on bracket (B).
12. If the optional storage bracket is not installed, store the crop dividers in a safe location.

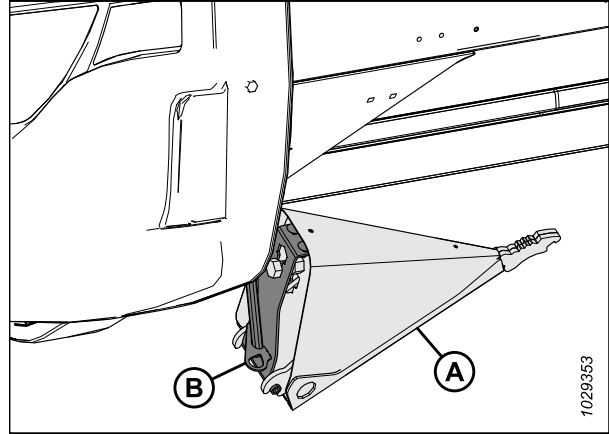


Figure 3.403: Optional Crop Divider Storage

### Installing Crop Dividers

Follow these instructions to properly install the crop dividers.

#### DANGER

To prevent bodily injury or death from the unexpected start-up or fall of a raised machine, always stop the engine, remove the key, and engage the safety props before going under the header for any reason.

#### DANGER

Ensure that all bystanders have cleared the area.

1. Start the engine.
2. Lower the reel fully.
3. Raise the header fully.
4. Shut down the engine, and remove the key from the ignition.
5. Engage the header safety props. For instructions, refer to the combine operator's manual.
6. If the optional storage bracket is installed, remove crop divider (A) from its storage position by lifting the crop divider so that bolt (B) clears the slot in storage bracket (C).
7. If the optional storage bracket is **NOT** installed, retrieve the crop dividers from where they were stored.
8. Open the endshield. For instructions, refer to [Opening Header Endshields, page 41](#).

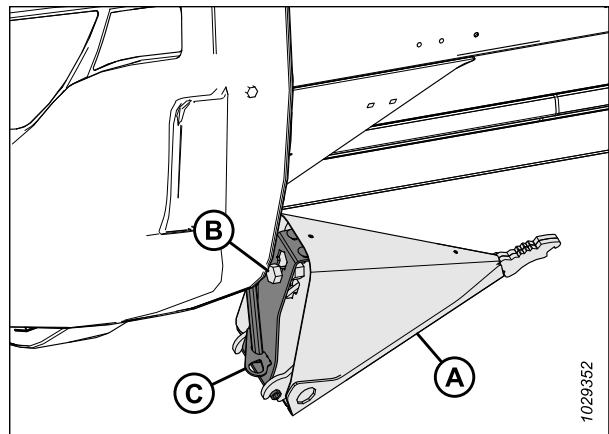


Figure 3.404: Optional Crop Divider

## OPERATION

9. Insert crop divider lugs (A) into holes in the endsheet.
10. Remove lynch pin (B) from latch (C).

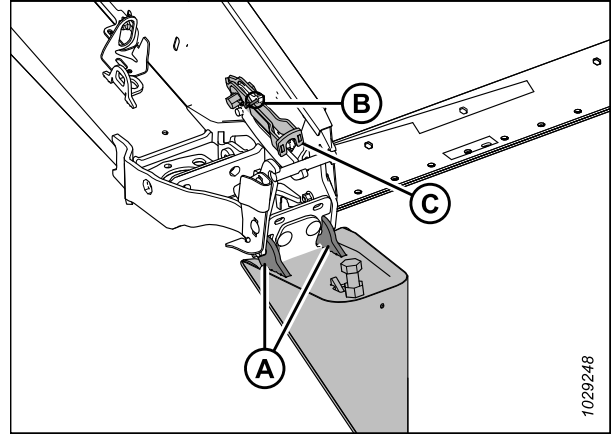


Figure 3.405: Crop Divider with Latch

11. Lift the forward end of latch (A) and crop divider (B).

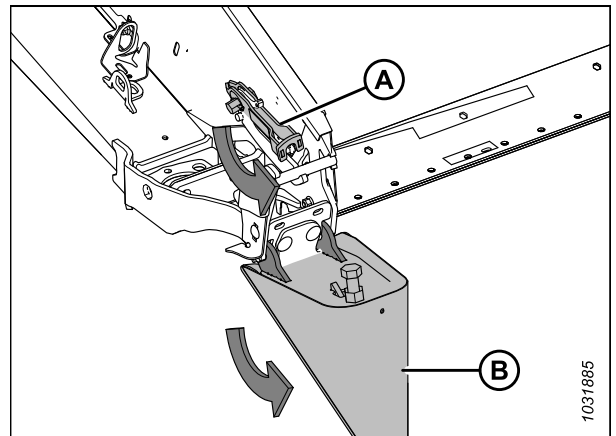


Figure 3.406: Crop Divider with Latch

12. Engage latch (A) onto crop divider bolt (B).
13. Rotate hex shaft (D) on latch (A) counterclockwise to engage lock.

**NOTE:**

Hex shaft (D) requires a torque of 40–54 Nm (30–40 lbf-ft) to close the latch. If adjustment is required, loosen latch (A) and adjust bolt (B) to correct the amount of torque required.

14. Secure the crop divider with lynch pin (C).
15. Close the endshield. For instructions, refer to [Closing Header Endshields, page 42](#).

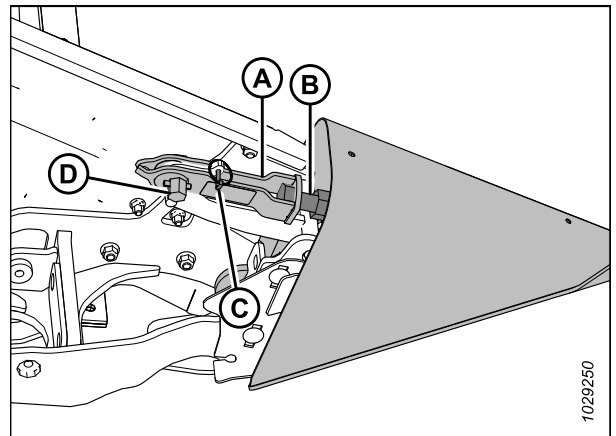


Figure 3.407: Crop Divider with Latch

## OPERATION

### Removing Floating Crop Dividers

Remove the floating crop dividers to install other attachments or the standard crop dividers.

#### DANGER

To prevent bodily injury or death from the unexpected start-up or fall of a raised machine, always stop the engine and remove the key from the ignition before making adjustments to the machine. NEVER climb onto or go underneath an unsupported header.

#### DANGER

Ensure that all bystanders have cleared the area.

1. Start the engine.
2. Lower the reel fully.
3. Raise the header 0.6–0.9 m (2–3 ft.) off of the ground.
4. Shut down the engine, and remove the key from the ignition.
5. Open the endshield.
6. Retrieve multi-tool (A) from the left endsheet.
7. Remove lynch pin (B).
8. Install multi-tool (A) onto hex shaft (C).
9. Rotate the multi-tool downwards until latch (D) releases from bolt (E).
10. Lift latch (D) up and off bolt (E).

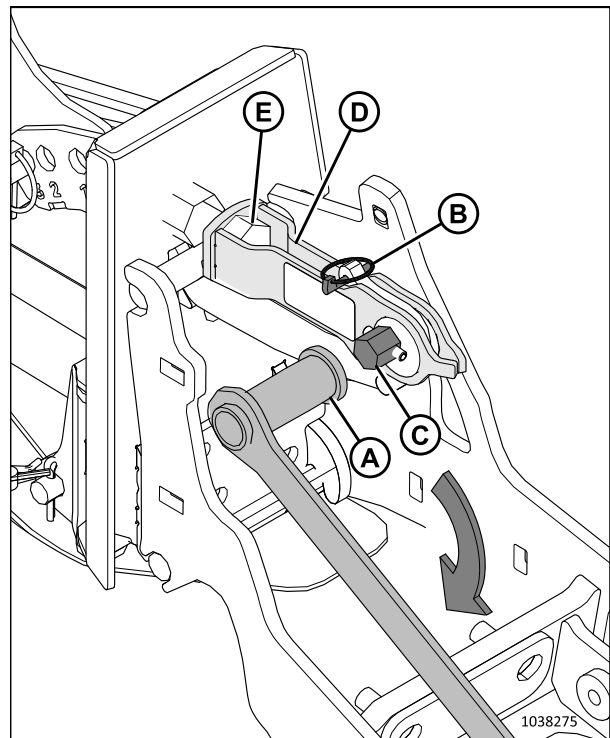


Figure 3.408: Floating Crop Divider Installed

## OPERATION

11. Tilt the floating crop divider forward and pull it out of the header.
12. Reinstall lynch pin (A).
13. Close the endshield.
14. Repeat Step 5, page 272 to Step 13, page 273 on the opposite end of the header to remove the opposite floating crop divider.

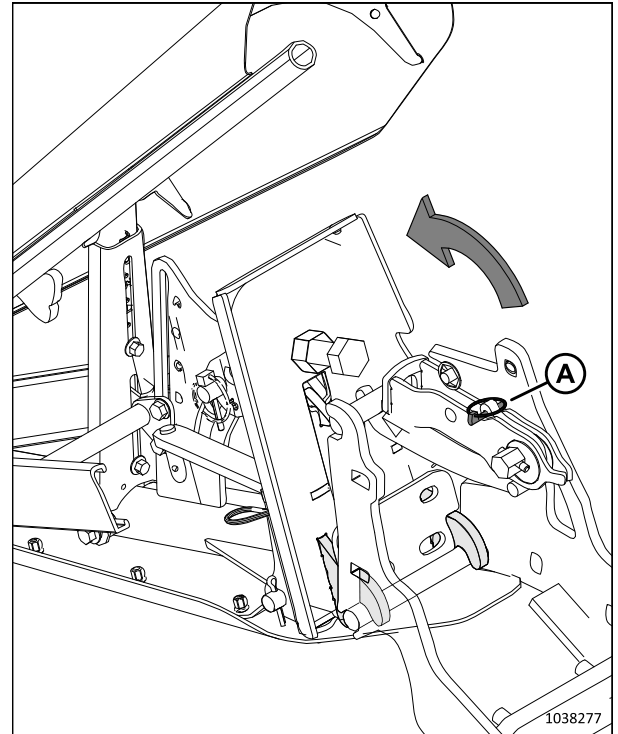


Figure 3.409: Latch Released

### *Installing Floating Crop Dividers*

Follow these instructions to properly install the floating crop dividers onto the header.

#### **DANGER**

To prevent bodily injury or death from the unexpected start-up or fall of a raised machine, always stop the engine and remove the key from the ignition before making adjustments to the machine. NEVER climb onto or go underneath an unsupported header.

#### **DANGER**

Ensure that all bystanders have cleared the area.

1. Start the engine.
2. Lower the reel fully.
3. Raise the header 0.6–0.9 m (2–3 ft.) off the ground.
4. Shut down the engine, and remove the key from the ignition.
5. Open the endshields.

## OPERATION

6. Remove lynch pin (A) from quick latch (B).
7. Attach multi-tool (C) (stored on the left endsheet) to hex shaft (D) and rotate to release latch (B).
8. If crop dividers (E) are installed, lift latch (B) off of bolt (F) and set the crop dividers aside.

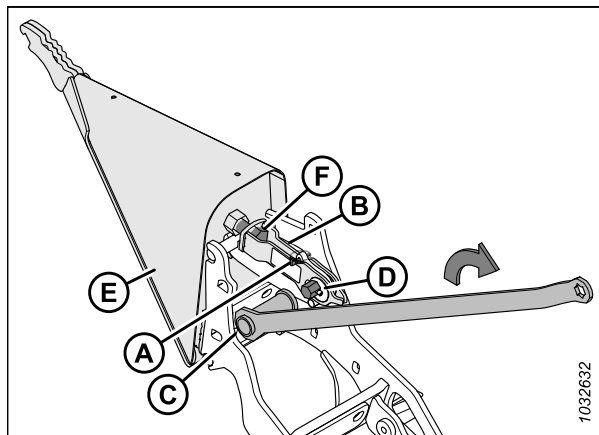


Figure 3.410: Crop Divider Installed

9. Insert crop divider lugs (A) into the slots in the header frame.

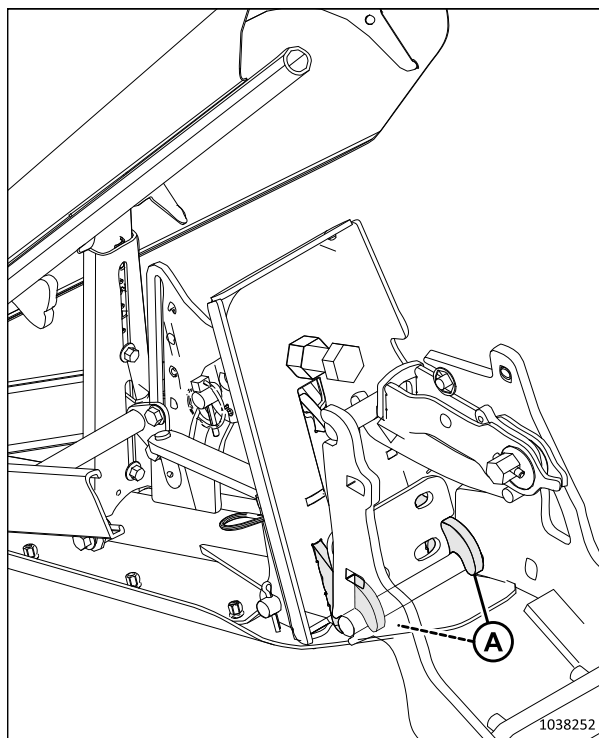


Figure 3.411: Crop Divider Installation

## OPERATION

10. Lift the forward end of quick latch (A), and rotate crop divider (B) up into position.

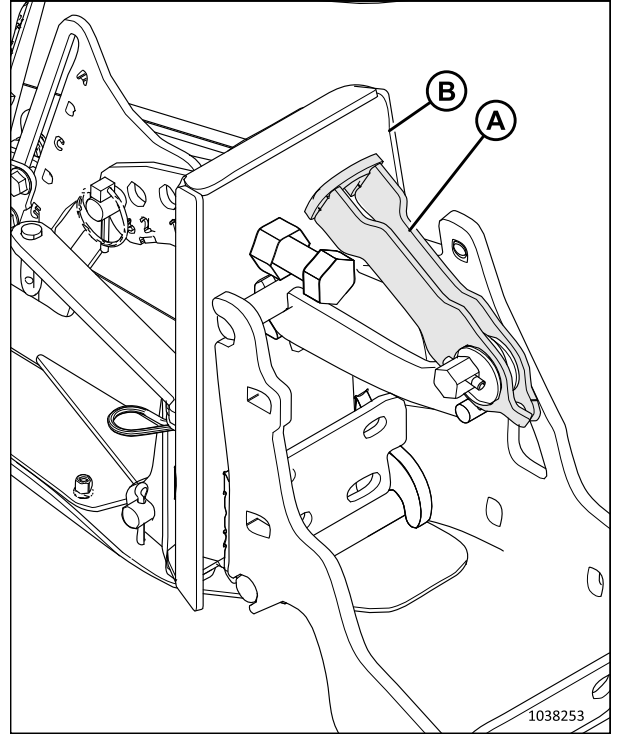


Figure 3.412: Quick Latch

11. Engage quick latch (A) onto the bolt.
12. Make sure the latch closes tightly and crop divider stop (B) contacts header stop (C).

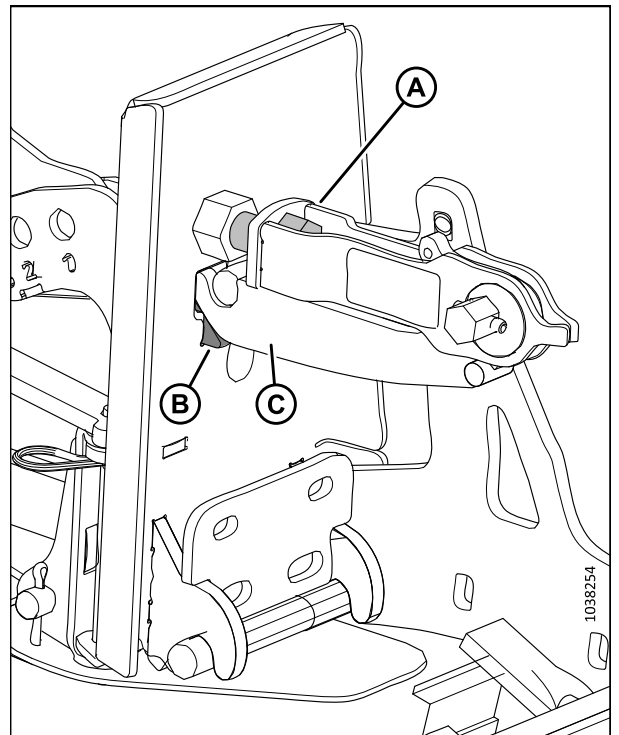


Figure 3.413: Crop Divider Latched to Header

## OPERATION

13. If the latch requires adjustment, loosen nut (A), and adjust the length of bolt (B) until it takes 40–54 Nm (30–40 lbf-ft) of torque on hex shaft (C) to close the latch.
14. Retighten nut (A).
15. Attach multi-tool (D) onto hex shaft (C) and rotate the multi-tool to lock the latch.
16. Install lynch pin (E) to secure the quick latch in place.
17. Repeat Step 6, page 274 to Step 16, page 276 on the opposite end of the header to install the opposite crop divider.
18. Close the endshields. For instructions, refer to *Closing Header Endshields*, page 42.
19. Check the float. For instructions, refer to *Checking and Adjusting Header Float*, page 210.
20. Check the wing balance. For instructions, refer to 3.9.4 *Checking and Adjusting Wing Balance*, page 226

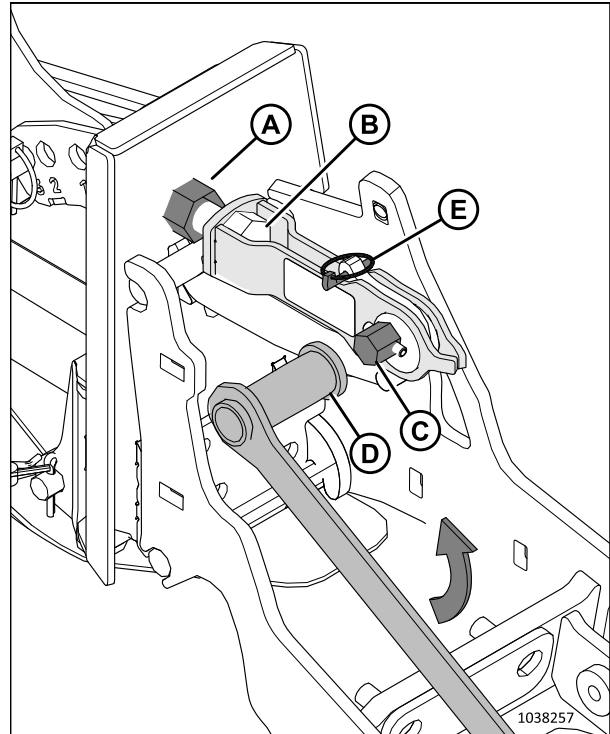


Figure 3.414: Latch Adjustment

### *Adjusting Floating Crop Dividers*

Crop dividers can be adjusted for different crop conditions.

#### **!** DANGER

To prevent bodily injury or death from the unexpected start-up or fall of a raised machine, always stop the engine and remove the key from the ignition before making adjustments to the machine. NEVER climb onto or go underneath an unsupported header.

#### **!** DANGER

Ensure that all bystanders have cleared the area.

1. Start the engine.
2. Lower the reel fully.
3. Raise the header 0.6–0.9 m (2–3 ft.) off the ground.
4. Shut down the engine, and remove the key from the ignition.



## OPERATION

5. Refer to the chart according to the stubble height range and reel configuration:
  - Field with a stubble height of 50–125 mm (2–5 in.), double- or triple-reel headers: refer to Step [6, page 278](#).
  - Field with a stubble height of 20–100 mm (3/4–4 in.), double- or triple-reel headers: refer to Step [7, page 279](#).
  - Cutterbar on the ground, field with a stubble height of 16–50 mm (5/8–2 in.), double- or triple-reel headers: refer to Step [8, page 280](#).
  - Field with a stubble height of 50–125 mm (2–5 in.), single-reel headers: refer to Step [9, page 281](#).
  - Field with a stubble height of 20–100 mm (3/4–4 in.), single-reel headers: refer to Step [10, page 282](#).
  - Cutterbar on the ground, field with a stubble height of 16–50 mm (5/8–2 in.), single-reel headers: refer to Step [11, page 283](#).

**Table 3.31 Floating Crop Divider Settings – Double- or Triple-Reel Header, Field with a Stubble Height of 50–125 mm (2–5 in.)**

6. Adjust the header according to the settings in the table row that describes the crop condition and the stubble height:										
a. Adjust the header angle.										
b. Adjust the header skid shoes.										
c. Adjust the floating crop divider (Down Stop to Top Deflector Side Rod) and confirm the range of motion set by the down stop does <b>NOT</b> contact the reel supports or the reel. For instructions, refer to Step 12, <i>page 284</i> to Step 18, <i>page 287</i> .										
	Stubble Height	Header Angle <sup>63</sup>	Header Skid Shoes	Down Stop	Nose Cone Fore-Aft Position	Top Deflector Height	Side Deflector Height	Top Deflector Side Rod		
<b>Standing Crop</b>	125 mm (5 in.)	A	Down	2	1 or 3	1	C	In		
	50 mm (2 in.)	E	Down	1	1 or 3	1.5	C	In		
<b>Lodged</b>	125 mm (5 in.)	A	Down	2	3 or 4	1	C	Out		
	50 mm (2 in.)	E	Down	1	3 or 4	2	D	Out		
<b>Severely Lodged<sup>64</sup></b>	125 mm (5 in.)	A	Down	2	4	3	D	Out		
	125 mm (5 in.)	A	Down	2	5	4	D	Out		
	50 mm (2 in.)	E	Down	1	4	3	C	Out		
	50 mm (2 in.)	E	Down	1	5	4	C	Out		

63. A (min) – E (max)

64. Crop canopy lower than 150 mm (6 in.)

**Table 3.32 Floating Crop Divider Settings – Double- or Triple-Reel Header, Field with a Stubble Height of 20–100 mm (3/4–4 in.)**

<p>7. Adjust the header according to the settings in the table row that describes the crop condition and the stubble height:</p> <ul style="list-style-type: none"> <li>a. Adjust the header angle.</li> <li>b. Adjust the header skid shoes.</li> <li>c. Adjust the floating crop divider (Down Stop to Top Deflector Side Rod) and confirm the range of motion set by the down stop does <b>NOT</b> contact the reel supports or the reel. For instructions, refer to Step 12, <a href="#">page 284</a> to Step 18, <a href="#">page 287</a>.</li> </ul>									
	Stubble Height	Header Angle <sup>65</sup>	Header Skid Shoes	Down Stop	Nose Cone Fore-Aft Position	Top Deflector Height	Side Deflector Height	Top Deflector Side Rod	
<b>Standing Crop</b>	100 mm (4 in.)	A	Middle	2	1 or 3	1	C	In	
	20 mm (3/4 in.)	E	Middle	1	1 or 3	1	C	In	
<b>Lodged</b>	100 mm (4 in.)	A	Middle	2	3	1	C	Out	
	100 mm (4 in.)	A	Middle	2	4	2	C	Out	
	20 mm (3/4 in.)	E	Middle	1	3	1	D	Out	
	20 mm (3/4 in.)	E	Middle	1	4	2	D	Out	
<b>Severely Lodged<sup>66</sup></b>	100 mm (4 in.)	A	Middle	2 or 3	4	3	D	Out	
	100 mm (4 in.)	A	Middle	2 or 3	5	4	D	Out	
	20 mm (3/4 in.)	E	Middle	1	4	3	C	Out	
	20 mm (3/4 in.)	E	Middle	1	5	4	C	Out	

65. A (min) – E (max)

66. Crop canopy lower than 150 mm (6 in.)

**Table 3.33 Floating Crop Divider Settings – Double- or Triple-Reel Header, Cutterbar on the Ground, Field with a Stubble Height of 16–50 mm (5/8–2 in.)**

<p>8. Adjust the header according to the settings in the table row that describes the crop condition and the stubble height:</p> <ul style="list-style-type: none"> <li>a. Adjust the header angle.</li> <li>b. Adjust the header skid shoes.</li> <li>c. Adjust the floating crop divider (Down Stop to Top Deflector Side Rod) and confirm the range of motion set by the down stop does <b>NOT</b> contact the reel supports or the reel. For instructions, refer to Step 12, <a href="#">page 284</a> to Step 18, <a href="#">page 287</a>.</li> </ul>									
	Stubble Height	Header Angle <sup>67</sup>	Header Skid Shoes	Down Stop	Nose Cone Fore-Aft Position	Top Deflector Height	Side Deflector Height	Top Deflector Side Rod	
<b>Standing Crop</b>	50 mm (2 in.)	A	Up	2	1 or 3	1	C	In	
	16 mm (5/8 in.)	E	Up	1	1	2	C	In	
	16 mm (5/8 in.)	E	Up	1	3	1	C	In	
<b>Lodged</b>	50 mm (2 in.)	A	Up	2	3	1	C	Out	
	50 mm (2 in.)	A	Up	3	4	1	C	Out	
	16 mm (5/8 in.)	E	Up	1	3 or 4	2	D	Out	
<b>Severely Lodged<sup>68</sup></b>	50 mm (2 in.)	A	Up	2 or 3	4	3	D	Out	
	50 mm (2 in.)	A	Up	2 or 3	5	4	D	Out	
	16 mm (5/8 in.)	E	Up	1	4	2.5	C	Out	
	16 mm (5/8 in.)	E	Up	1	5	4	C	Out	

<sup>67</sup>. A (min) – E (max)

<sup>68</sup>. Crop canopy lower than 150 mm (6 in.)

**Table 3.34 Floating Crop Divider Settings – Single-Reel Header, Field with a Stubble Height of 50–125 mm (2–5 in.)**

<p>9. Adjust the header according to the settings in the table row that describes the crop condition and the stubble height:</p> <ul style="list-style-type: none"> <li>a. Adjust the header angle.</li> <li>b. Adjust the header skid shoes.</li> <li>c. Adjust the floating crop divider (Down Stop to Top Deflector Side Rod) and confirm the range of motion set by the down stop does <b>NOT</b> contact the reel supports or the reel. For instructions, refer to Step 12, <i>page 284</i> to Step 18, <i>page 287</i>.</li> </ul>									
	Stubble Height	Header Angle <sup>69</sup>	Header Skid Shoes	Down Stop	Nose Cone Fore-Aft Position	Top Deflector Height	Side Deflector Height	Top Deflector Side Rod	
<b>Standing or Lodged Crop</b>	125 mm (5 in.)	A	Down	2	4	1	A-E	In or Out	
	50 mm (2 in.)	E	Down	1	5	2.5	A-E	In or Out	
<b>Severely Lodged<sup>70</sup></b>	125 mm (5 in.)	A	Down	2	4	1	A-E	In or Out	
	50 mm (2 in.)	E	Down	1	5	2.5	A-E	In or Out	

69. A (min) – E (max)

70. Crop canopy lower than 150 mm (6 in.)

**Table 3.35 Floating Crop Divider Settings – Single-Reel Header, Field with a Stubble Height of 20–100 mm (3/4–4 in.)**

<p>10. Adjust the header according to the settings in the table row that describes the crop condition and the stubble height:</p> <ul style="list-style-type: none"> <li>a. Adjust the header angle.</li> <li>b. Adjust the header skid shoes.</li> <li>c. Adjust the floating crop divider (Down Stop to Top Deflector Side Rod) and confirm the range of motion set by the down stop does <b>NOT</b> contact the reel supports or the reel. For instructions, refer to Step 12, <i>page 284</i> to Step 18, <i>page 287</i>.</li> </ul>									
	Stubble Height	Header Angle <sup>71</sup>	Header Skid Shoes	Down Stop	Nose Cone Fore-Aft Position	Top Deflector Height	Side Deflector Height	Top Deflector Side Rod	
<b>Standing or Lodged Crop</b>	100 mm (4 in.)	A	Middle	2	5	1	A-E	In or Out	
	20 mm (3/4 in.)	E	Middle	1	5	2.5	A-E	In or Out	
<b>Severely Lodged<sup>72</sup></b>	100 mm (4 in.)	A	Middle	2	4	1	A-E	In or Out	
	20 mm (3/4 in.)	E	Middle	1	5	2.5	A-E	In or Out	

<sup>71</sup>. A (min) – E (max)

<sup>72</sup>. Crop canopy lower than 150 mm (6 in.)

**Table 3.36 Floating Crop Divider Settings – Single-Reel Header, Cutterbar on the Ground, Field with a Stubble Height of 16–50 mm (5/8–2 in.)**

<p>11. Adjust the header according to the settings in the table row that describes the crop condition and the stubble height:</p> <ul style="list-style-type: none"> <li>a. Adjust the header angle.</li> <li>b. Adjust the header skid shoes.</li> <li>c. Adjust the floating crop divider (Down Stop to Top Deflector Side Rod) and confirm the range of motion set by the down stop does <b>NOT</b> contact the reel supports or the reel. For instructions, refer to Step 12, <i>page 284</i> to Step 18, <i>page 287</i>.</li> </ul>										
	Stubble Height	Header Angle <sup>73</sup>	Header Skid Shoes	Down Stop	Nose Cone Fore-Aft Position	Top Deflector Height	Side Deflector Height	Top Deflector Side Rod		
<b>Standing or Lodged Crop</b>	50 mm (2 in.)	A	Up	2	4	1	A-E	In or Out		
	16 mm (5/8 in.)	E	Up	1	5	2.5	A-E	In or Out		
<b>Severely Lodged<sup>74</sup></b>	50 mm (2 in.)	A	Up	2	4	1	A-E	In or Out		
	16 mm (5/8 in.)	E	Up	1	5	2.5	A-E	In or Out		

<sup>73</sup>. A (min) – E (max)

<sup>74</sup>. Crop canopy lower than 150 mm (6 in.)

## OPERATION

12. **Down stop:** Remove lynch pin (A) from the clevis pin, and remove the clevis pin. Retain both the lynch pin and the clevis pin for reinstallation.
13. Tilt the divider, then reinstall the clevis pin into the appropriate numbered hole "1" to "3". Secure the clevis pin with the lynch pin.

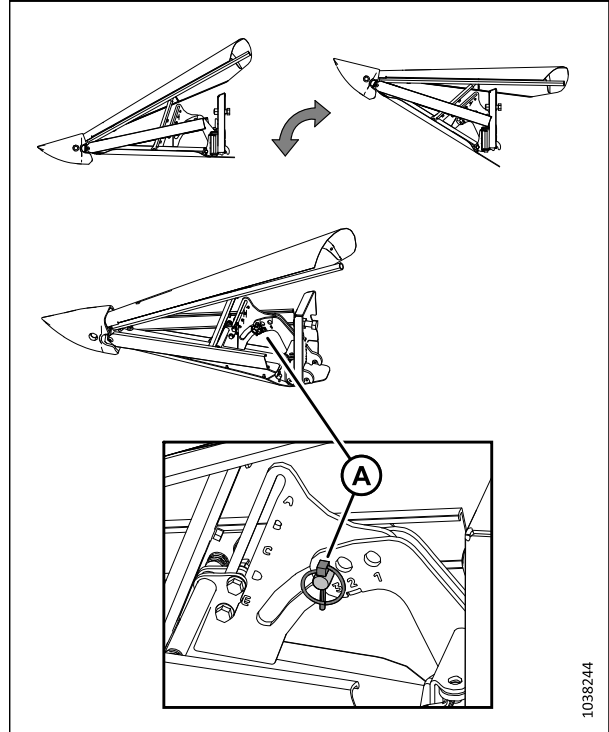


Figure 3.415: Down Stop Adjustment

14. **Nose cone fore-aft:** Remove bolt (A), move the tube, then install the bolt into one of the five tube holes.

### NOTE:

- In example (B), the bolt is installed in tube hole "1".
- In example (C), the bolt is installed in tube hole "5".

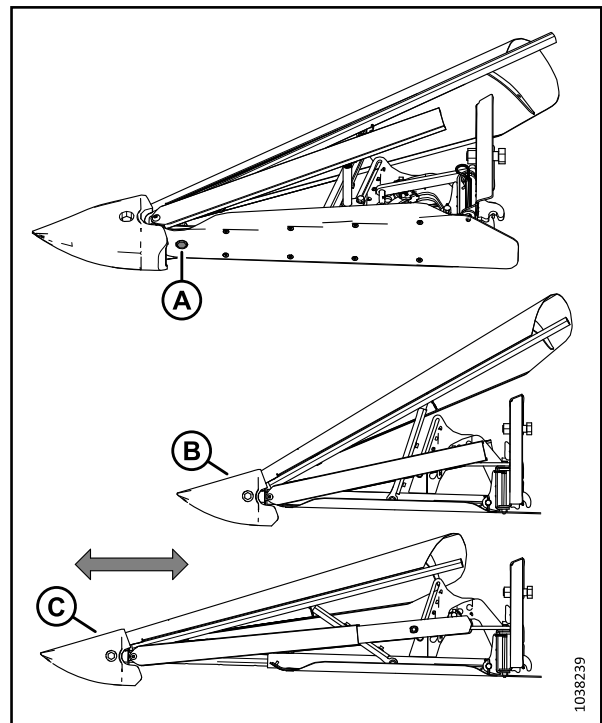


Figure 3.416: Nose Cone Fore-aft Adjustment



## OPERATION

15. **Top deflector height:** Loosen the nuts on bolts (A). Slide the center support to the desired setting (1 to 4.5), then tighten the nuts.

- Align the dots with the support to set half-increments. Example (B) is 2.5.
- Align the number with the support to set full increments. Example (C) is 2.

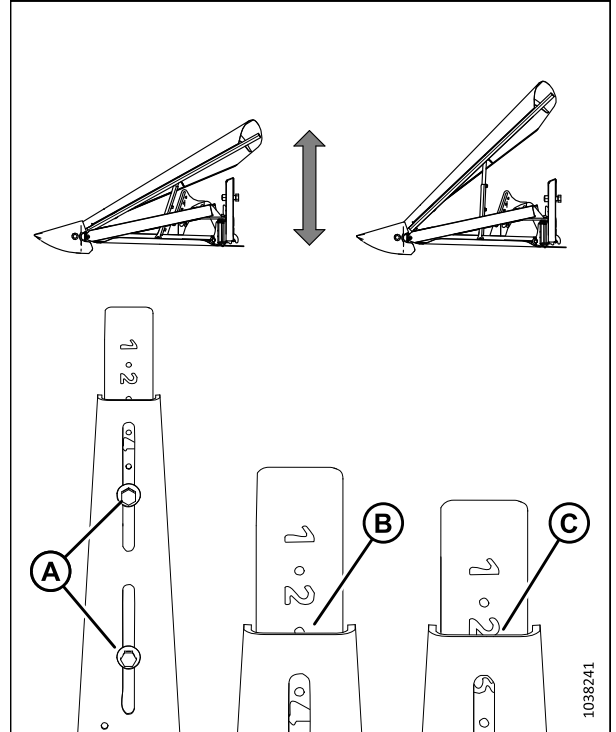


Figure 3.417: Top Deflector Height Adjustment

16. **Side deflector height:** Loosen the nuts on bolts (A). Slide deflectors until notch (B) is at a desired setting (A to E), then tighten the nuts.

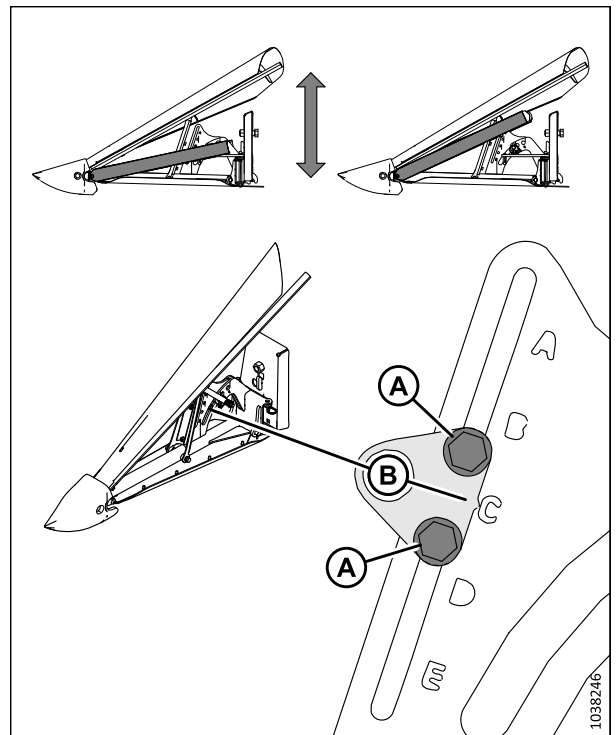


Figure 3.418: Side Deflector Height Adjustment

## OPERATION

17. **Top deflector side rod:** Loosen nut (A) and bolt (B), then swing rod (C). Tighten nut (A) to 39 Nm (29 lbf·ft). Tighten bolt (B) to 52 Nm (38 lbf·ft).

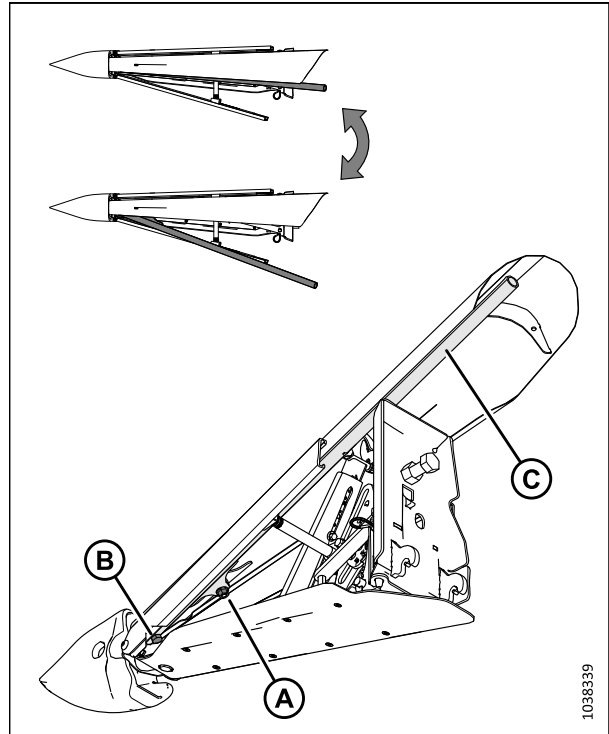


Figure 3.419: Top Deflector Side Rod Adjustment

1038339

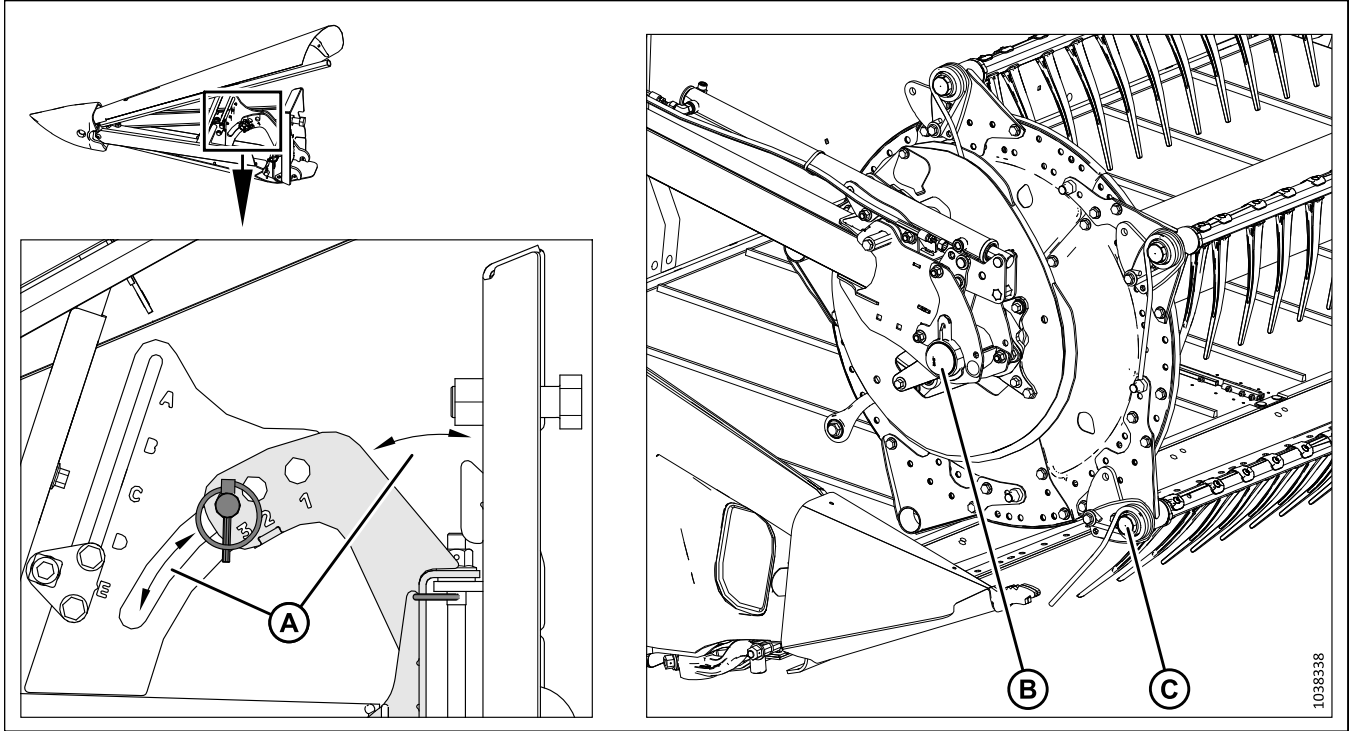


Figure 3.420: Floating Crop Divider Range of Motion

18. **Range of motion check:** Lift and lower the floating crop divider through the range of motion (A) set by the down-stop. Confirm the floating divider does **NOT** contact reel supports (B) or reel (C).

**IMPORTANT:**

When checking for interference between the floating crop dividers and a **SINGLE REEL**, also make sure that the floating crop dividers do **NOT** contact the reel drive.

### 3.9.16 Crop Divider Rods

Use crop divider rods with crop dividers to help separate crop when harvesting. The crop divider rods are most useful when the crop is bushy or down. In standing crops, use only crop dividers.

The following table outlines which crops should be harvested with divider rods and which crops should be harvested without divider rods.

Table 3.37 Recommended Use for Crop Divider Rods

With Divider Rods		Without Divider Rods
Alfalfa	Lodged cereal	Edible beans
Canola	Peas	Milo
Flax	Soybeans	Rice
Grass seed	Sudan grass	Soybeans
Lentils	Winter forage	Standing cereal

## OPERATION

### Removing Crop Divider Rods

Crop divider rods can be removed from the ends of the crop dividers and stored on the header.

1. Loosen bolt (B) and remove crop divider rod (A) from both sides of the header.

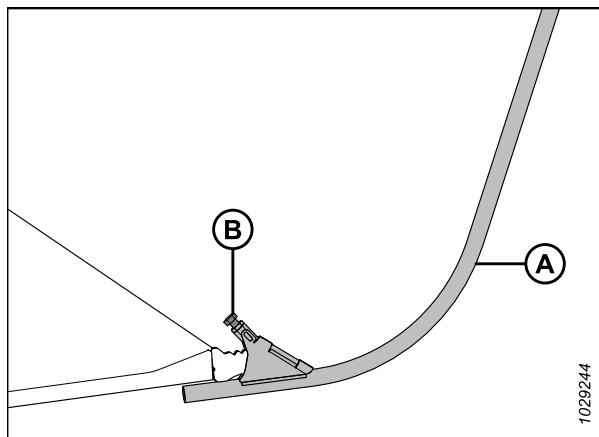


Figure 3.421: Crop Divider Rod

2. Store both crop divider rods (B) on the right endsheet.
3. Secure the rods with lynch pin (A).

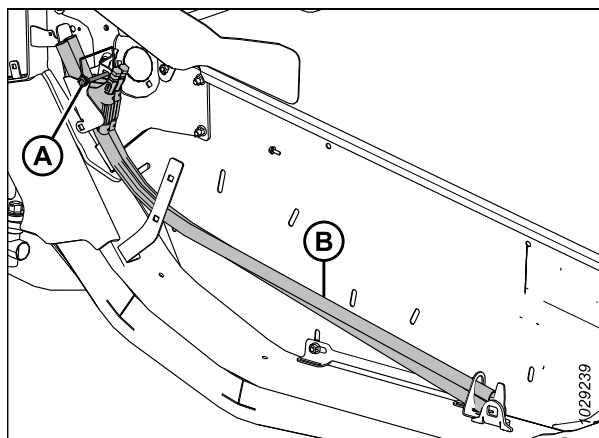


Figure 3.422: Right Endsheets

### Installing Crop Divider Rods

The crop divider rods can be installed on the ends of the crop dividers to help separate bushy crop.

1. Open the right and the left endshields. For instructions, refer to [Opening Header Endshields, page 41](#).

## OPERATION

2. Undo lynch pin (A) securing divider rods (B) to the header endsheet.
3. Remove the divider rods from their storage location.
4. Reinstall lynch pin (A).

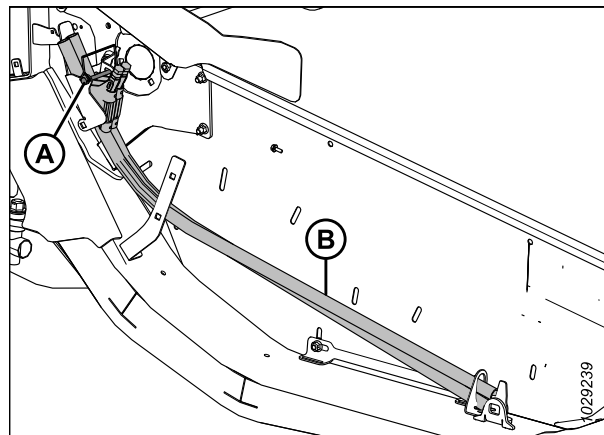


Figure 3.423: Divider Rods

5. Position crop divider rod (A) on the tip of the crop divider. Tighten bolt (B).
6. Repeat Step 2, [page 289](#) to Step 5, [page 289](#) on the opposite end of the header.
7. Close the right and left endshields. For instructions, refer to [Closing Header Endshields, page 42](#).

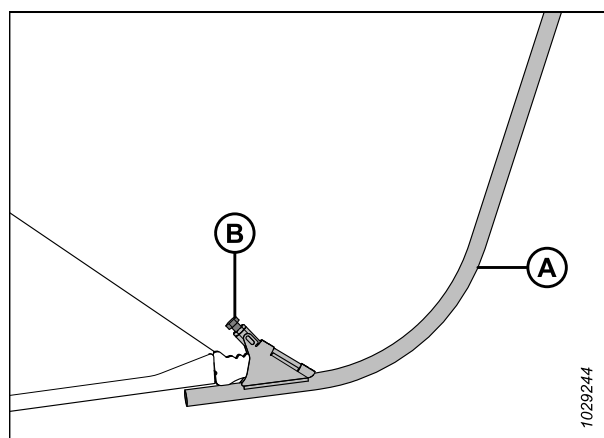


Figure 3.424: Divider Rod on Crop Divider

### *Optional Rice Divider Rods*

The optional rice divider rods are used to assist with tall and tangled rice crops. They can be installed on the ends of the crop dividers.

Rice divider rods improve performance in tall and tangled rice crops. For more information, refer to [5.1.7 Rice Divider Rod Kit, page 790](#).

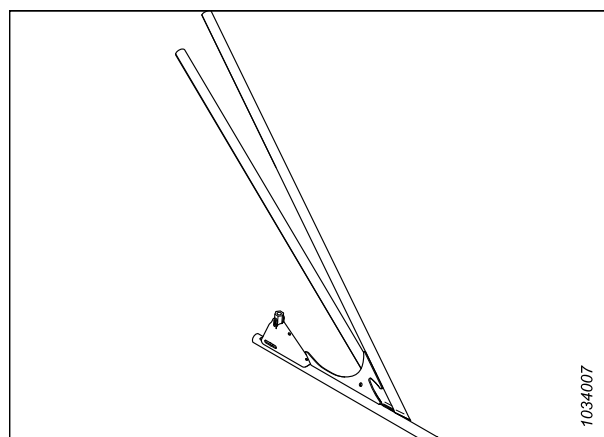


Figure 3.425: Optional Divider Rod for Rice

## AUTO HEADER HEIGHT CONTROL SYSTEM

Rice divider rods are stored at the rear of both endsheets on storage bracket (A) and secured in place with pin (B). The installation and removal of these rods follow the same procedures as standard crop divider rods.

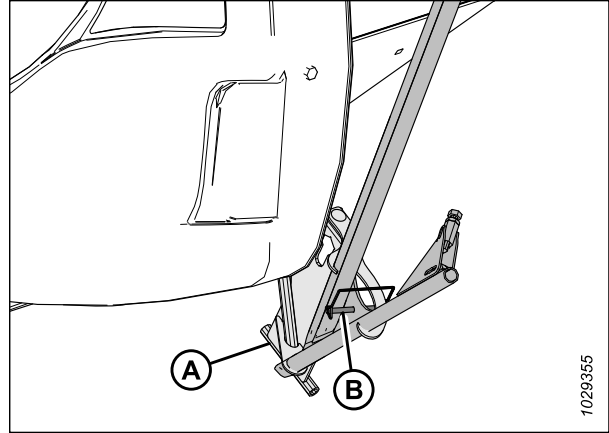


Figure 3.426: Rice Divider Rod Storage

## Auto Header Height Control System

The auto header height control (AHHC) system works in conjunction with the AHHC option available on certain combine models.

Two Hall effect sensors (A) are installed on the float setting indicators on the float module. These sensors send signals to the combine, which allow the combine to maintain the header at a consistent cutting height and the optimum float setting as the header follows the contours of the ground.

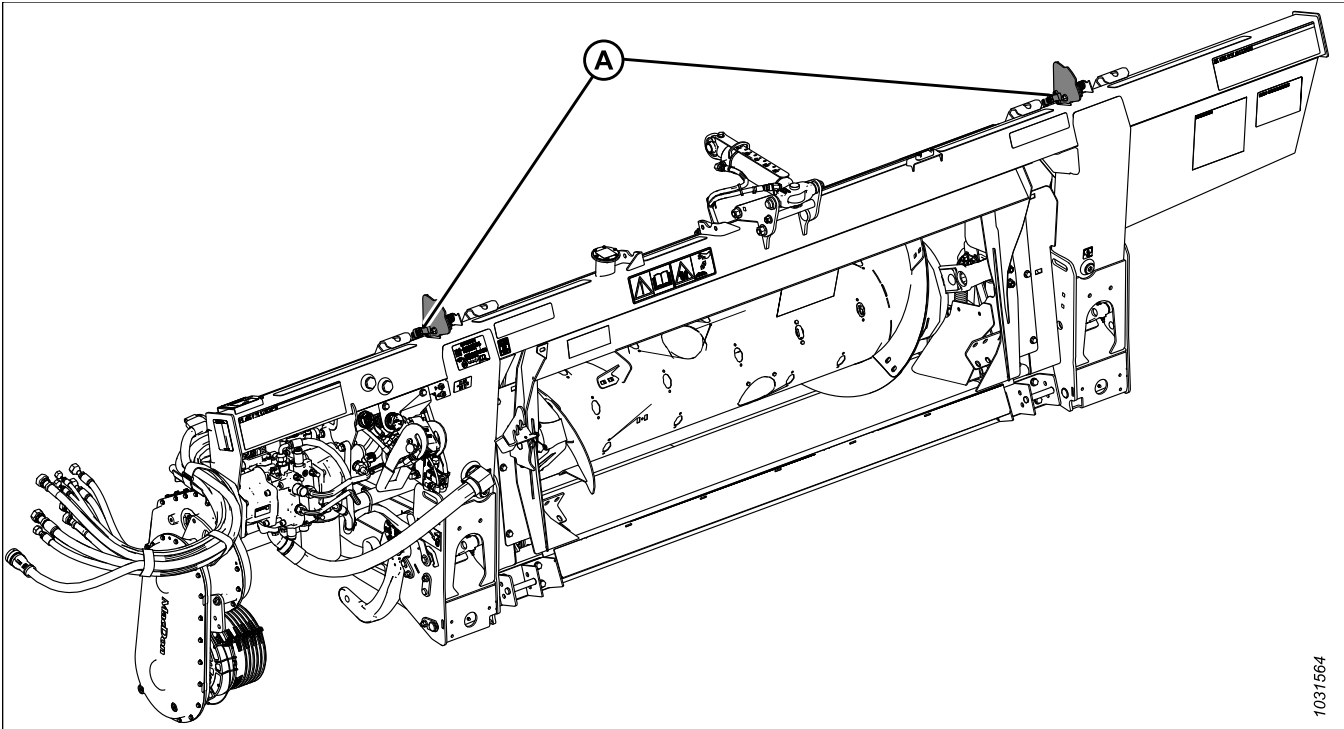


Figure 3.427: FM200 Float Module

Complete the following tasks before using the AHHC system:

1. Prepare the combine to use the AHHC feature (applies only to some combine models—refer to the instructions for your combine).

## AUTO HEADER HEIGHT CONTROL SYSTEM

2. Calibrate the sensors used by the AHHC system so that the combine can correctly interpret data from the Hall effect sensors on the float module. For more information, refer to the combine operator's manual.

To configure the AHHC system for a particular combine model, refer to the relevant procedure:

- *3.5 Case IH 130 and 140 Series Mid-Range Combines, page 301*
- *3.6 Case IH 120, 230, 240, and 250 Series Combines, page 312*
- *3.7 Challenger® and Massey Ferguson® 6 and 7 Series Combines, page 335*
- *3.8 CLAAS/CAT Lexion 500 Series and Model 600 Combines, page 345*
- *3.9 CLAAS Lexion 600 and 700 Series Combines, page 357*
- *3.10 CLAAS Lexion 6000, 7000 and 8000 Series, and CLAAS Trion 600 and 700 Series Combines, page 370*
- *3.11 Gleaner® R65, R66, R75, R76, and Pre-2016 S Series Combines, page 383*
- *3.12 Gleaner® S9 Series Combines, page 396*
- *3.13 IDEAL™ Series Combines, page 415*
- *3.15 John Deere 70 Series Combines, page 440*
- *3.16 John Deere S and T Series Combines, page 448*
- *3.17 John Deere S7 Series Combines, page 469*
- *3.18 John Deere X9 Series Combines, page 483*
- *3.19 New Holland CR and CX Series Combines – 2014 and Earlier, page 500*
- *3.20 New Holland Combines – CR Series (2015 and Later) and CH, page 513*
- *3.21 Rostselmash Combines – RSM 161, T500, and TORUM 785, page 536*

### 3.1 Auto Header Height Control Sensor Operation

The position sensors supplied with the auto header height control (AHHC) system communicate data about the header's height to the combine's computer.

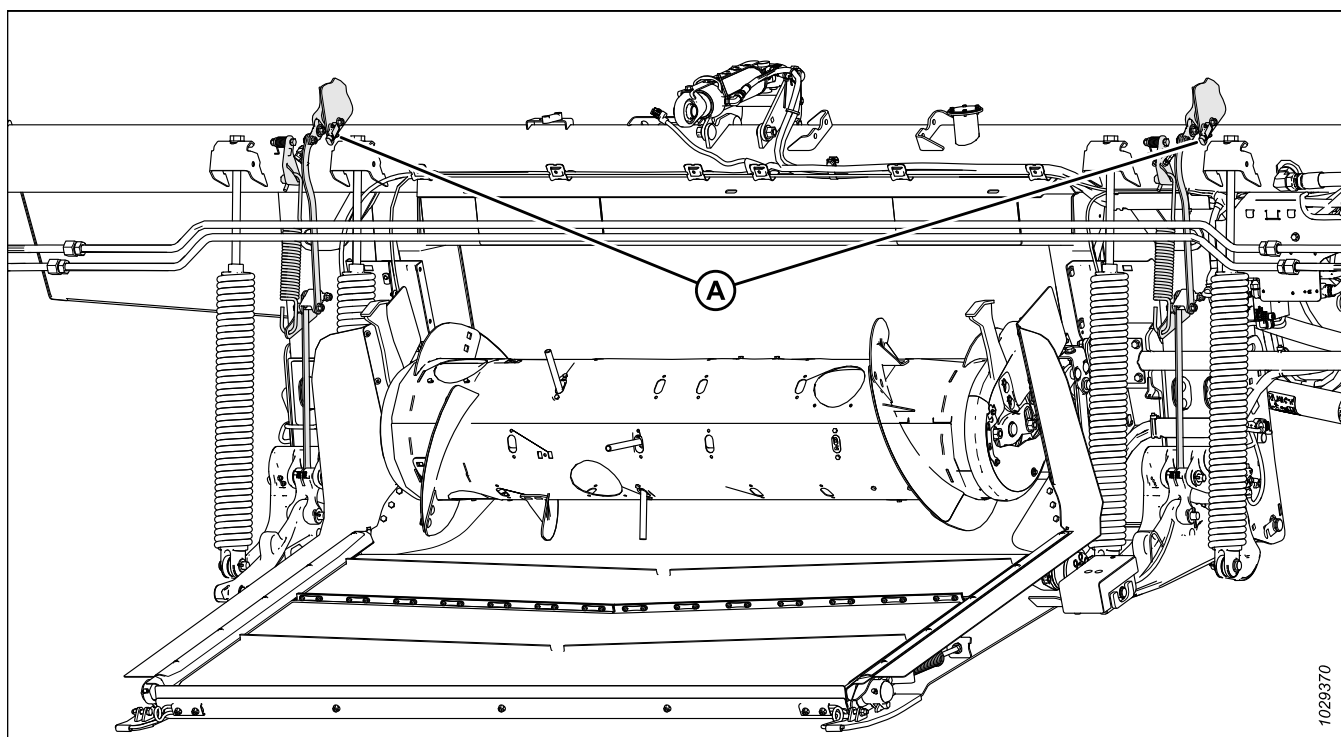


Figure 3.428: Height Control Sensor Locations on Float Module

#### *Auto header height control sensor overview*

Two Hall effect sensors are installed on float indicator needles (A). As the header rises and falls, the sensors communicate the header's height to the combine's computer. The combine's computer will, in response, raise or lower the feeder house so that the header can maintain a consistent cutting height.

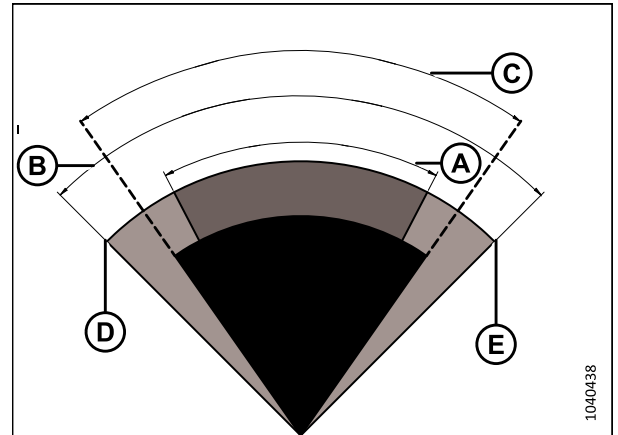
The normal operating signal voltages for the sensors fall between 0.7 VDC and 4.3 VDC. An increase in sensor voltage correlates to an increase in header height, while a decrease in sensor voltage correlates to a decrease in header height. Any sensor error results in a 0 V signal, which indicates either a faulty sensor or insufficient voltage supply.



## AUTO HEADER HEIGHT CONTROL SYSTEM

### ***Auto header height control sensor voltage ranges***

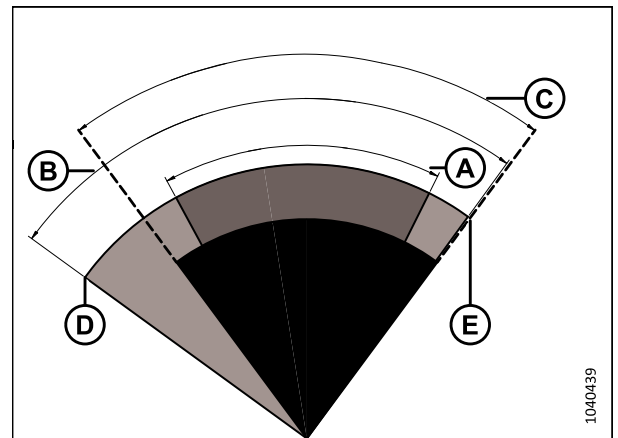
The voltage reported by the sensors occurs in a range of at least 2.5 V (Range [A]) and at most 4.0 V (Range [B]). The ideal voltage range for the sensors is 0.7–4.3 V (Range C), a total range of 3.6 V. If the voltage is too close to low end (D) of the voltage range, calibrating the AHHC system will be difficult. A properly set sensor will have sufficient clearance on both ends of the voltage range.



**Figure 3.429: Optimal Sensor Voltage Range**

- A - Minimum Voltage Range – 2.5 V      B - Maximum Voltage Range – 4.0 V
- C - Ideal Voltage Range – 3.6 V          D - Minimum Voltage – 0.5 V
- E - Maximum Voltage – 4.5 V

A sensor that is configured so that the voltage range (for example, voltage range [C]) is too close to the sensor's low voltage limit (D) or high voltage limit (E) will have difficulty staying within the sensor's operating range of ideal operating range (A) of 0.7–4.3 V. If the sensor reports values that are above maximum voltage (E) or minimum voltage (D), the AHHC system will stop functioning correctly.



**Figure 3.430: Sensor Range Set too Close to Voltage Limit**

- A - Minimum Voltage Range – 2.5 V      B - Maximum Voltage Range – 4.0 V
- C - Configured Voltage Range            D - Minimum Voltage – 0.5 V
- E - Maximum Voltage – 4.5 V



### 3.2 Recommended Sensor Output Voltages for Combines

The auto header height control (AHHC) sensor output must be within a specific voltage range for each combine, or the AHHC feature will not work properly. The recommended lower and upper voltage values for best AHHC operation are provided.

**Table 3.38 Combine Voltage Limits**

Combine	Lower Voltage Limit (V)	Upper Voltage Limit (V)	Minimum Range (V)
All models of combine	0.7	4.3	2.5
<b>NOTE:</b> If a New Holland combine is equipped with the 10 V system, and the voltage is checked on the combine display, the following voltages will be displayed:	2.8	7.2	4.1–4.4

### 3.3 Manually Checking Voltage Limits

For the auto header height (AHC) system to function correctly, the voltages reported to the combine by the header height sensors must occur within the specified range.

**NOTE:**

One of the following plugs will be installed in connector P600 (A). This plug determines how the voltage signal is sent to the combine:

- Averaging Plug (MD #328560 [B7489]): This plug sends the average of both sensors to the combine.
- Lateral Tilt Plug (MD #328318 [B7196]): This plug sends separate voltage signals from both sensors to the combine, with averaged center signals.
- Pass-Through Plug (MD #323698 [B7490]): Each sensor sends a voltage signal directly to the combine. There are no averaged center signals.

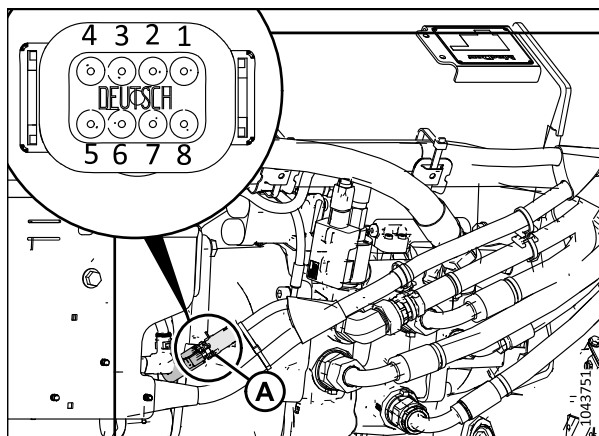


Figure 3.432: Connector

**NOTE:**

On some combine models, you can see the voltage on the combine display.

**⚠ DANGER**

Ensure that all bystanders have cleared the area.

**⚠ DANGER**

To prevent injury or death from the unexpected start-up of the machine, always stop the engine and remove the key from the ignition before leaving the operator’s seat for any reason.

1. Park the combine on a level surface.
2. Position the header so that the cutterbar is 254–356 mm (10–14 in.) off the ground.

**Checking sensor upper voltage limit**

3. Extend the guard angle until header angle indicator (A) is at position E on the center-link.
4. Shut down the engine, and remove the key from the ignition.

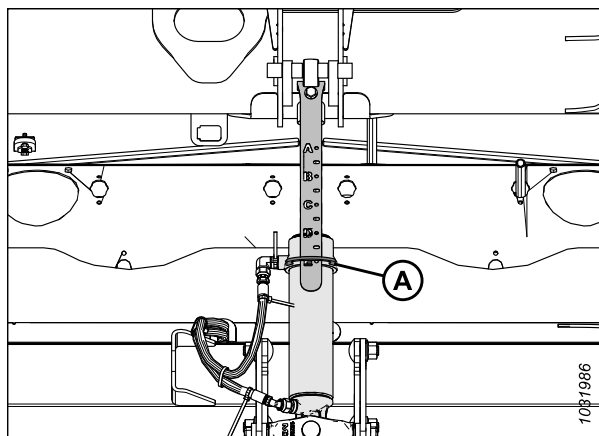


Figure 3.433: Center-Link

**CAUTION**

To prevent cuts, pinches, and other bodily harm to the person checking the down stops, ensure that nobody is manually lifting, bouncing, or moving the header in any way while the down stop washer is being touched and checked for movement.

5. Ensure that the float lock linkage is on the down stops (washer [A] cannot move) at both locations.

**NOTE:**

If the header is **NOT** on the down stops, the voltage may go out of range during operation and cause the AHHC system to malfunction. To fix the problem, make the header heavier by decreasing the float. For instructions, refer to [Checking and Adjusting Header Float, page 210](#).

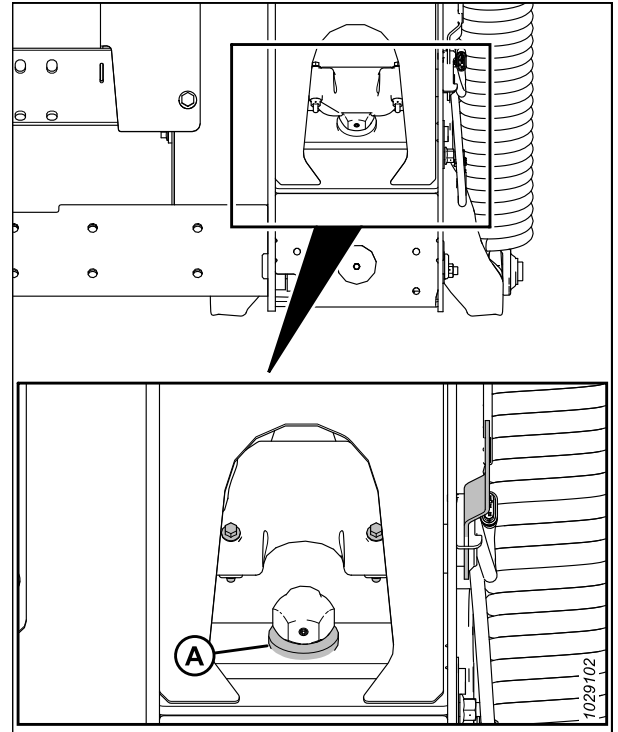


Figure 3.434: Down Stop Washer

6. If the pointer is not on zero, loosen bolt (A) and rotate float indicator plate (B) until pointer (C) is on 0 (D). Tighten the nut on bolt (A).

**NOTE:**

Use zero dot (E) above the decal to correctly set the indicator needle.

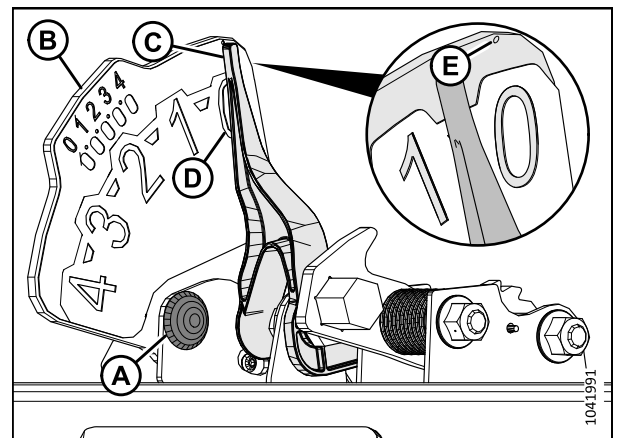


Figure 3.435: Float Indicator

## AUTO HEADER HEIGHT CONTROL SYSTEM

7. Locate connector P600 (A) at the left of the float module.
8. Remove plug (B).
9. Insert the key into the ignition and turn it to the RUN position.
10. Using a digital multimeter, check connector P600 for power from the combine. The multimeter should read 5 V at pin 7.
  - Pin 7 - FM2215E – power
  - Pin 8 - FM2515E – ground
11. On connector P600, compare the voltage reported by the left sensor (pins 1 and 8) and the right sensor (pins 3 and 8) to the upper range specified in [3.2 Recommended Sensor Output Voltages for Combines, page 295](#).
  - Pin 1 - FM3326A – left sensor signal
  - Pin 3 - FM3328A – right sensor signal
  - Pin 8 - FM2515E – ground

### NOTE:

With the float lock linkage on the down stops, the upper voltage reading should ideally be the same on both (left and right) sensors, however a difference of 0.1–0.2 V is acceptable.

12. If you need to adjust the voltage, then loosen nuts (A), reposition sensor (B) in the indicator plate, then tighten nuts (A) to 3 Nm (2.2 lbf·ft [22 lbf·in]).

### NOTE:

While tightening the nuts, make sure that sensor (B) does **NOT** move in the indicator plate.

13. Turn the key to the OFF position, and remove the key from the ignition.

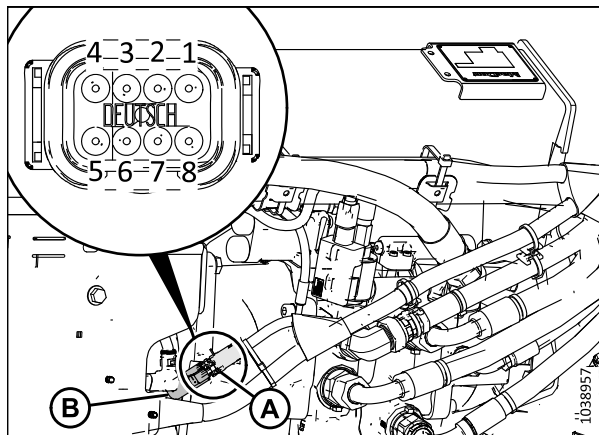


Figure 3.436: Connector P600 – View from Rear

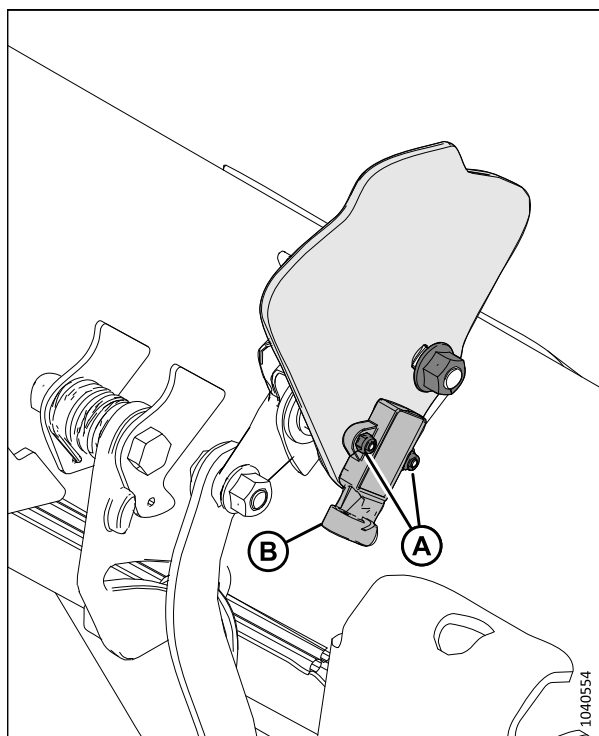


Figure 3.437: Left Float Indicator Plate

## AUTO HEADER HEIGHT CONTROL SYSTEM

### Checking sensor lower voltage limit

14. Extend the guard angle until header angle indicator (A) is at position **E** on the center-link.
15. Lower the header fully.
16. Shut down the engine, and remove the key from the ignition.

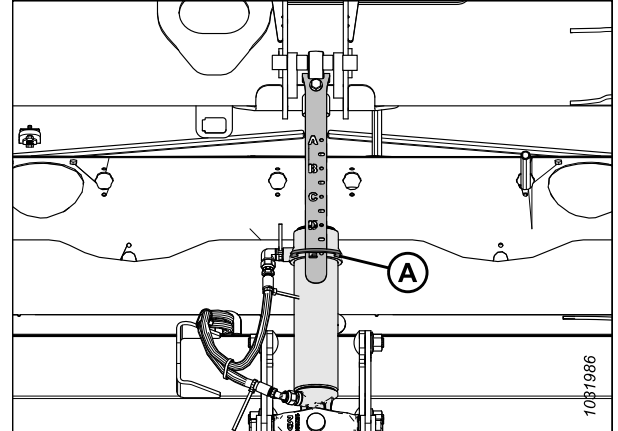


Figure 3.438: Center-Link

17. Float indicator pointer (A) should be at 4 (B).
18. Insert the key and turn it to the RUN position.
19. On connector P600, compare the voltage reported by the left sensor (pins 1 and 8) and the right sensor (pins 3 and 8) to the lower voltage specified in [3.2 Recommended Sensor Output Voltages for Combines, page 295](#).
  - Pin 1 - FM3326A – left sensor signal
  - Pin 3 - FM3328A – right sensor signal
  - Pin 8 - FM2515E – ground
20. If you need to adjust the voltage, refer to Step [12, page 298](#) for instructions.

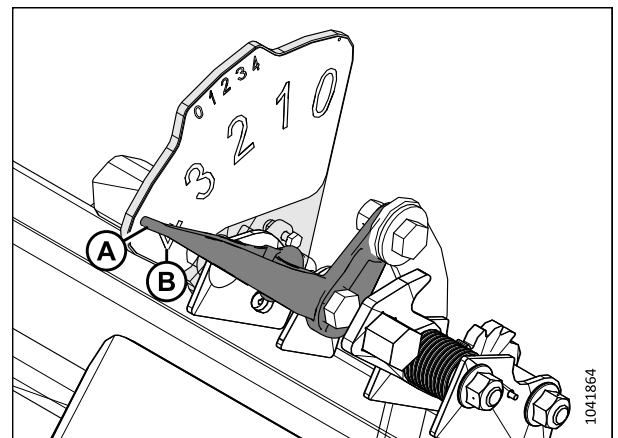


Figure 3.439: Left Float Indicator – View from Rear

### 3.4 10 Volt Adapter – New Holland Combines Only

New Holland combines equipped with a 10 V system require a 10 V adapter in order to calibrate the auto header height control (AHHC) system.

If a 10 V New Holland combine does not have adapter (A) installed, the AHHC output will always read 0 V, regardless of the sensor's position.

For instructions on checking the sensor voltages, refer to [3.19.1 Checking Voltage Range from Combine Cab – New Holland CR and CX Series, page 500](#) or [3.3 Manually Checking Voltage Limits, page 296](#).

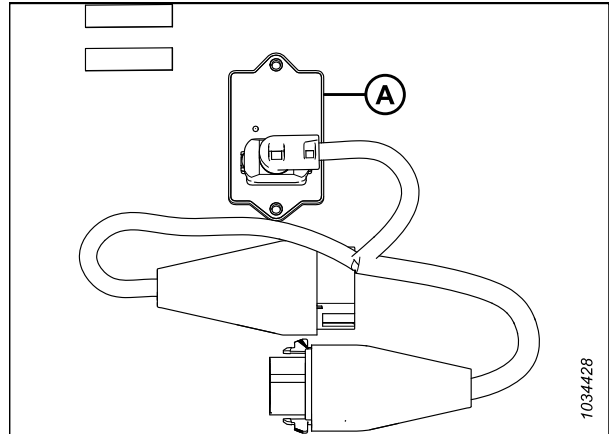


Figure 3.440: 10 V Adapter (B7241)



### 3.5 Case IH 130 and 140 Series Mid-Range Combines

To make the auto header height control (AHHC) system compatible for Case IH 130 and 140 Series mid-range combines, you must configure the reel speed settings, set up the AHHC controls, and calibrate the AHHC system to ensure that it is working correctly.

#### 3.5.1 Checking Voltage Range from Combine Cab – Case IH 5130, 5140, 6130, 6140, 7130, and 7140

The auto header height control sensor needs to operate within a specific voltage range in order to work properly.

**NOTE:**

Changes may have been made to the combine controls or the display since this document was published. For the most up-to-date information, refer to the combine operator’s manual.

**! DANGER**

To prevent bodily injury or death from the unexpected start-up of the machine, always stop the engine and remove the key from the ignition before making adjustments to the machine.

**! DANGER**

Ensure that all bystanders have cleared the area.

1. Position the header so that the cutterbar is 254–356 mm (10–14 in.) off the ground.
2. Shut down the engine, and remove the key from the ignition.
3. Unlock the header float. For instructions, refer to *Locking / Unlocking Header Float, page 221*.
4. Lock the header wings. For instructions, refer to *Operating in Rigid Mode, page 224*.

**! CAUTION**

To prevent cuts, pinches, and other bodily harm to the person checking the down stops, ensure that nobody is manually lifting, bouncing, or moving the header in any way while the down stop washer is being touched and checked for movement.

5. Ensure that the float lock linkage is on the down stops (washer [A] cannot move) at both locations.

**NOTE:**

If the header is **NOT** on the down stops, the voltage may go out of range during operation and cause the AHHC system to malfunction. To fix the problem, make the header heavier by decreasing the float. For instructions, refer to *Checking and Adjusting Header Float, page 210*.

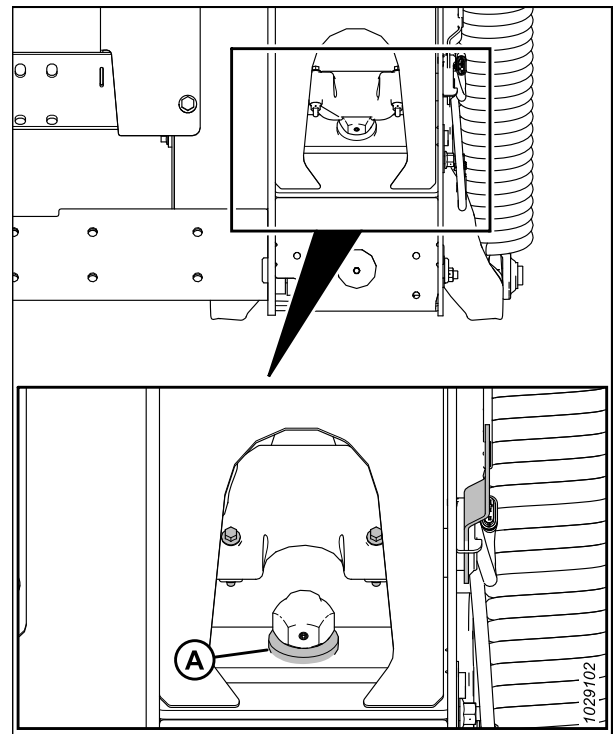


Figure 3.441: Down Stop Washer

## AUTO HEADER HEIGHT CONTROL SYSTEM

- If the pointer is not on zero, loosen bolt (A) and rotate float indicator plate (B) until pointer (C) is on 0 (D). Tighten the nut on bolt (A).

**NOTE:**

Use zero dot (E) above the decal to correctly set the indicator needle.

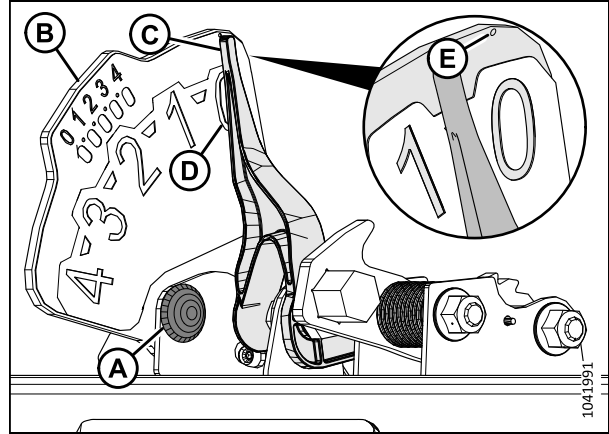


Figure 3.442: Float Indicator

- On the main page of the combine display, select DIAGNOSTICS (A). The DIAGNOSTICS page appears.

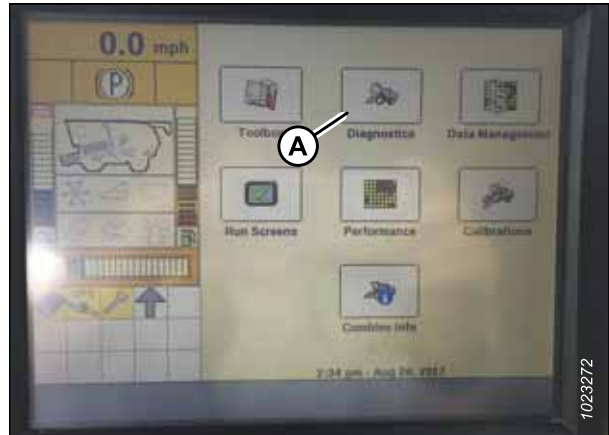


Figure 3.443: Case IH Combine Display

- Select SETTINGS (A). The SETTINGS page appears.
- From the GROUP menu, select HEADER (B).

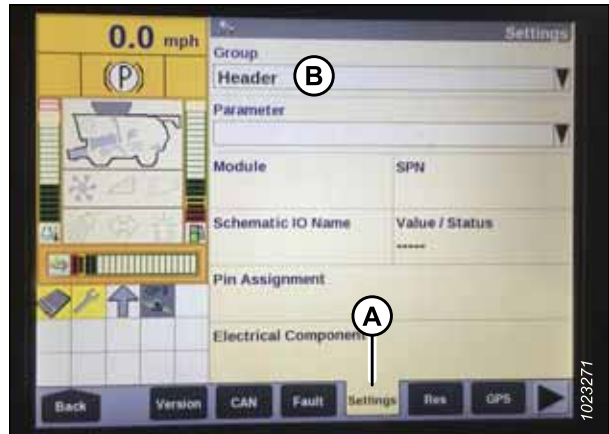


Figure 3.444: Case IH Combine Display

## AUTO HEADER HEIGHT CONTROL SYSTEM

10. From the PARAMETER menu, select LEFT HEIGHT/TILT SENSOR (A).



Figure 3.445: Case IH Combine Display

11. The SETTINGS page updates to display the voltage in VALUE/STATUS field (A). Lower the feeder house fully, and then raise it 254–356 mm (10–14 in.) off the ground to view the full range of voltage readings.
12. If the sensor voltage is not within the lower and upper limits, or if the range between the lower and upper limits is insufficient, refer to [3.3 Manually Checking Voltage Limits](#), page 296.



Figure 3.446: Case IH Combine Display

### 3.5.2 Header Settings Quick Reference – Case IH 130 and 140 Series

The recommended auto header height control (AHHC) settings for an FD2 Series FlexDraper® header operating with a Case IH 130 and 140 Series combine are provided.

**NOTE:**

Changes may have been made to the combine controls or the display since this document was published. For the most up-to-date information, refer to the combine operator’s manual.

**Table 3.39 Header Settings – Case IH 130 and 140 Series**

Setup Parameter	Suggested Setting	
Cutting type	Platform	
Header pressure float	Not installed	
HHC height sensitivity <sup>75</sup>	Two-sensor system	250
	One-sensor system	180
HHC tilt sensitivity	150	

75. If hunting occurs during operation, decrease the HHC HEIGHT SENSITIVITY setting by 20 points at a time until hunting no longer occurs.

## AUTO HEADER HEIGHT CONTROL SYSTEM

**Table 3.39 Header Settings – Case IH 130 and 140 Series (continued)**

Setup Parameter	Suggested Setting	
Reel drive type	Standard 19-tooth drive sprocket	4
	Optional high-torque 14-tooth drive sprocket	5
	Optional high-torque 10-tooth drive sprocket	6
Reel height sensor	Yes	
Autotilt	Two-sensor system	YES
	One-sensor system	NO

### 3.5.3 Setting up Header on Combine Display – Case IH 5130, 5140, 6130, 6140, 7130, and 7140

To set up the header to work with the combine, you will need to access the HEADER SETUP page on the combine display.

**NOTE:**

Changes may have been made to the combine controls or the display since this document was published. For the most up-to-date information, refer to the combine operator's manual.

1. On the main page of the combine display, select TOOLBOX icon (A).

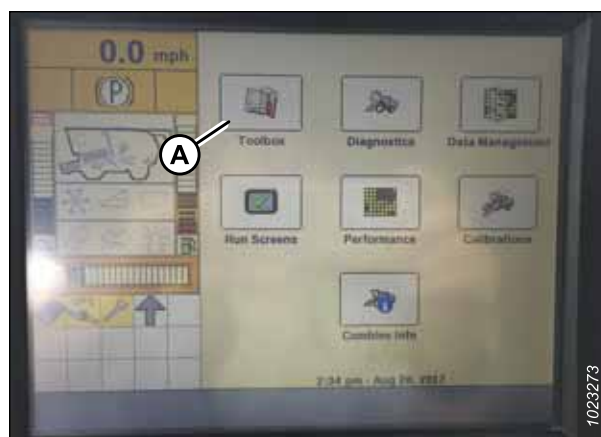


Figure 3.447: Case IH Combine Display

2. Select HEAD 1 tab (A). The HEADER SETUP page appears.

**NOTE:**

To locate the HEAD 1 tab, you may need to use side arrows (C).

3. From CUTTING TYPE menu (B), select PLATFORM.

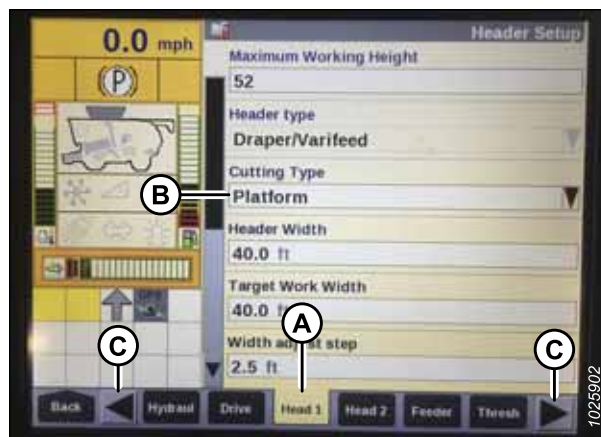


Figure 3.448: Case IH Combine Display

## AUTO HEADER HEIGHT CONTROL SYSTEM

4. Select HEAD 2 tab (A). The HEADER SETUP 2 page appears.
5. From HEADER PRESSURE FLOAT menu (B), select NOT INSTALLED.

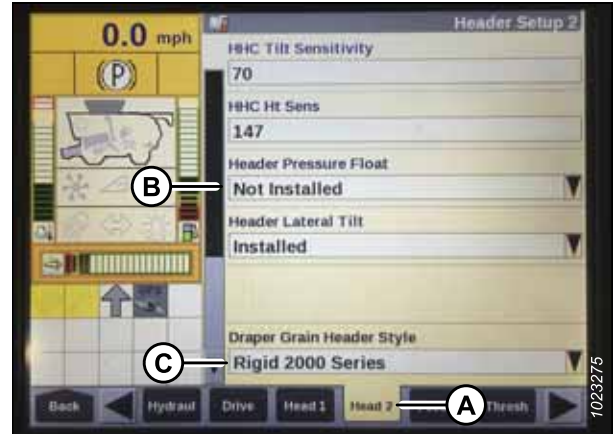


Figure 3.449: Case IH Combine Display

6. Locate HHC HEIGHT SENSITIVITY field (A). Enter the following settings:
  - **Two-sensor system:** Set HHC HEIGHT SENSITIVITY to 250.
  - **Single-sensor system:** Set HHC HEIGHT SENSITIVITY to 180.

**NOTE:**

If the combine continually raises and lowers the header during operation (a behavior termed “hunting”), decrease the HHC HEIGHT SENSITIVITY setting by 20 points at a time until hunting no longer occurs.

7. Set HHC TILT SENSITIVITY (B) to 150. Increase or decrease this value as desired.
8. From REEL DRIVE TYPE menu (A), select one of the following:

- If the combine is equipped with a standard 19-tooth drive sprocket, select 4.
- If the combine is equipped with an optional high-torque 14-tooth drive sprocket, select 5.
- If the combine is equipped with an optional high-torque 10-tooth drive sprocket, select 6.



Figure 3.450: Case IH Combine Display

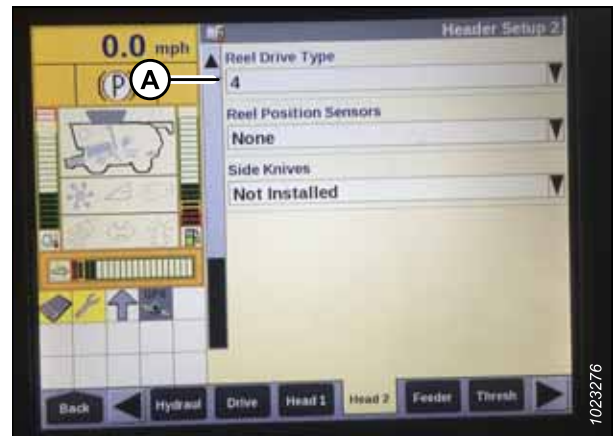


Figure 3.451: Case IH Combine Display



## AUTO HEADER HEIGHT CONTROL SYSTEM

9. From REEL HEIGHT SENSOR menu (A), select YES.



Figure 3.452: Case IH Combine Display

10. Locate AUTOTILT field (A).

- **Two-sensor system:** Select YES.
- **Single-sensor system:** Select NO.



Figure 3.453: Case IH Combine Display

### 3.5.4 Calibrating Auto Header Height Control – Case IH 5130, 5140, 6130, 6140, 7130, and 7140 Combines with Software Version below 28.00

The auto header height control (AHHC) sensor output must be calibrated for each combine.

#### DANGER

To prevent bodily injury or death from the unexpected start-up of the machine, always stop the engine and remove the key from the ignition before making adjustments to the machine.

#### DANGER

Ensure that all bystanders have cleared the area.

#### NOTE:

Changes may have been made to the combine controls or the display since this document was published. For the most up-to-date information, refer to the combine operator's manual.

#### NOTE:

If the header float is set too light, it can prevent the calibration of the AHHC. In order to prevent the header from separating from the float module, it may be necessary to change the float to a heavier setting during calibration.

## AUTO HEADER HEIGHT CONTROL SYSTEM

1. Park the combine on a level surface.
2. Ensure that the header is level with the ground. If adjustment is required:
  - Ensure that the combine is parked on a level surface.
  - If equipped, use the combine's lateral tilt to level the feeder house with the ground.
  - If further adjustment is required, shut the engine off, remove the key from the ignition, and ensure that the combine's tires are inflated to the correct pressure.

**NOTE:**

Spirit level (A) is located on top of the float module frame. The header is level if the bubble is in the center of the spirit level.

3. Ensure that the center-link is set to **D**.

**NOTE:**

When calibration is complete, adjust the center-link back to the desired header angle. For instructions, refer to [3.9.5 Header Angle, page 232](#).

4. Adjust the reel fore-aft position so that the indicator is at position **6**.
5. Position the header so that the cutterbar is 254–356 mm (10–14 in.) off the ground.
6. Shut down the engine, and remove the key from the ignition.

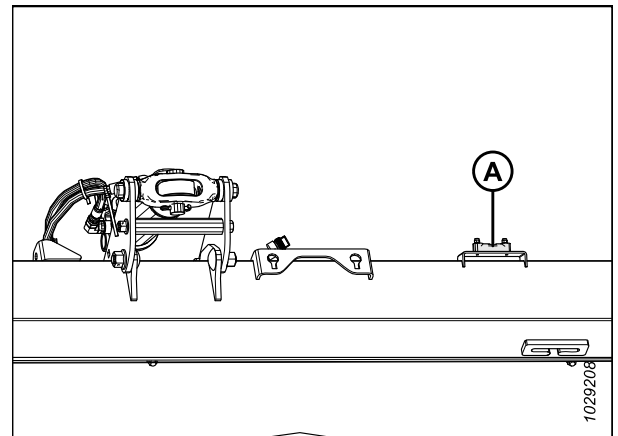


Figure 3.454: Spirit Level

## AUTO HEADER HEIGHT CONTROL SYSTEM

### CAUTION

To prevent cuts, pinches, and other bodily harm to the person checking the down stops, ensure that nobody is manually lifting, bouncing, or moving the header in any way while the down stop washer is being touched and checked for movement.

7. Ensure that the float lock linkage is on the down stops (washer [A] cannot move) at both locations.

#### NOTE:

If the header is **NOT** on the down stops, the voltage may go out of range during operation and cause the AHHC system to malfunction. To fix the problem, make the header heavier by decreasing the float. For instructions, refer to [Checking and Adjusting Header Float, page 210](#).

8. Unlock the header float. For instructions, refer to [Locking / Unlocking Header Float, page 221](#).
9. Lock the header wings. For instructions, refer to [Operating in Rigid Mode, page 224](#).

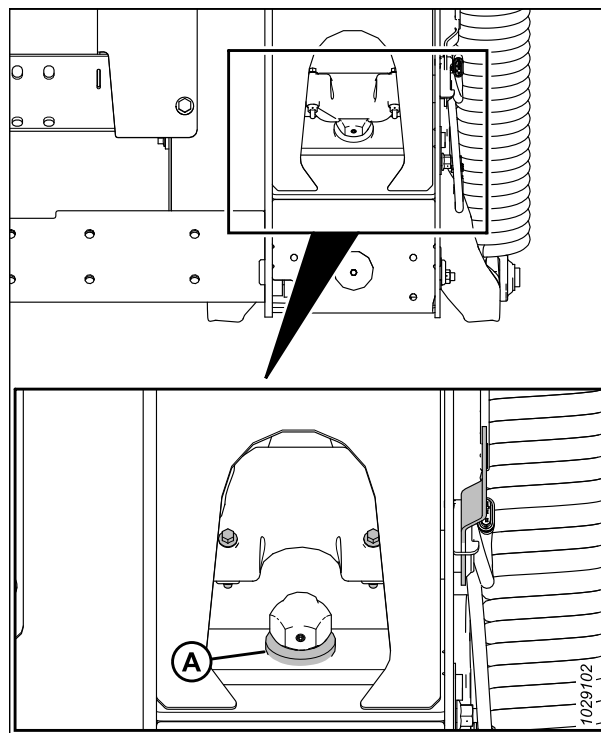


Figure 3.455: Down Stop Washer

10. Select the DIAGNOSTICS button from the Home Screen, then select VERSION tab (A).
11. Ensure that the software version is **lower than 28.00**. If the software version is higher than 28.00, refer to [3.6.4 Calibrating Auto Header Height Control – Case IH Combines with Version 28.00 or Higher Software, page 320](#).



Figure 3.456: Case IH Combine Display

12. Locate the HEADER CONTROL switch on the right console. Set the HEADER CONTROL to HT (AHHC mode).
13. Hold the DOWN button for 10 seconds to lower the combine feeder house (the feeder house should stop moving).
14. Hold the RAISE button until the feeder house travels all the way up. It will stop 0.6 m (2 ft.) above the ground for 5 seconds, then resume traveling upward. This indicates that the calibration procedure was successful.
15. If the float was changed to a heavier setting to complete calibration, adjust the header to the recommended float weight.



### 3.5.5 Setting Preset Cutting Height – Case IH 5130, 5140, 6130, 6140, 7130, and 7140

The header's cutting and raised positions can be configured as presets on the combine's control console.

**NOTE:**

Changes may have been made to the combine controls or the display since this document was published. For the most up-to-date information, refer to the combine operator's manual.

**⚠ DANGER**

Ensure that all bystanders have cleared the area.

**NOTE:**

Indicator (A) should be at position 0 (B) when the header is 254–356 mm (10–14 in.) above the ground. When the header is on the ground, the indicator should be at position 1 (C) for low ground pressure, and at position 4 (D) for high ground pressure. Crop and soil conditions determine the amount of float to use. The ideal float setting is as light as possible without the header bouncing or missing crop. Operating with a heavy float setting prematurely wears the cutterbar wearplates.

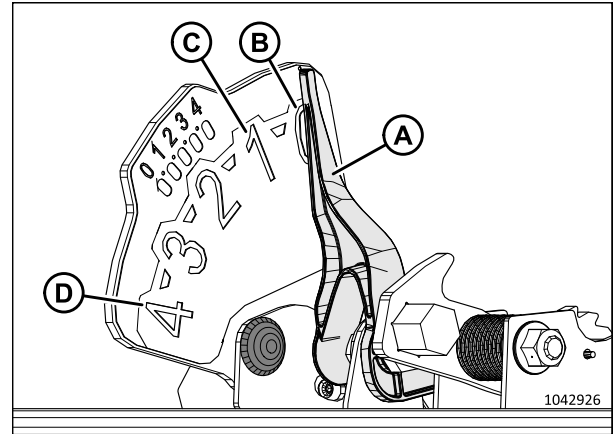


Figure 3.457: Float Indicator

1. Engage the separator and the header.
2. Move the header to the desired cutting height.
3. Press 1 on button (A). A yellow indicator next to the button will light up.

**NOTE:**

Always set the header position **BEFORE** setting the reel position. If the header and the reel are set at the same time, the reel setting will not be saved.

4. Move the reel to the desired working position.
5. Press 1 on button (A). A yellow indicator next to the button will light up.

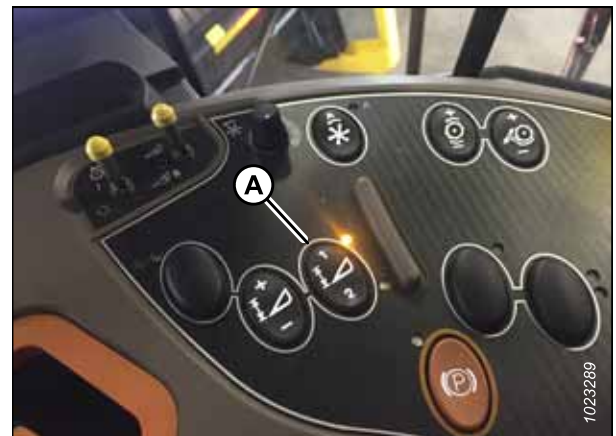


Figure 3.458: Case Combine Console

## AUTO HEADER HEIGHT CONTROL SYSTEM

6. Move the header to a second desired cutting height.
7. Press 2 on button (A). A yellow indicator next to the button will light up.
8. Move the reel to the desired working position.
9. Press 2 on button (A). A yellow indicator next to the button will light up.



Figure 3.459: Case Combine Console

The up and down arrows should now appear in MANUAL HEIGHT box (A) on the RUN 1 page on the combine display. This indicates that the auto header height control (AHHC) is functioning.



Figure 3.460: Case Combine Display – Run 1 Page

10. To enable the preset cutting heights, activate AHHC button (A) to place the header on the ground. To enable the first preset, tap the button once. To enable the second preset, tap the button twice.

To lift the header to its maximum working height, hold the SHIFT button behind the control handle while pressing AHHC button (A).



Figure 3.461: Case Combine Control Handle

## AUTO HEADER HEIGHT CONTROL SYSTEM

11. The maximum working height can be adjusted on the HEADER SETUP page on the combine display. Enter the desired height in MAXIMUM WORKING HEIGHT field (A).



Figure 3.462: Case Combine Display – Header Setup Page

12. If necessary, adjust the position of one of the presets by using button (A) on the combine console.



Figure 3.463: Case Combine Console

## 3.6 Case IH 120, 230, 240, and 250 Series Combines

To make your header's auto header height control (AHHC) system compatible with the combine, configure the reel speed settings, set up the AHHC controls, and calibrate the AHHC system to ensure that it is working correctly.

### 3.6.1 Checking Voltage Range from Combine Cab – Case IH, 120, 230, 240, and 250 Series Combines

In order for the auto header height control (AHHC) system to work correctly, the header height sensors must detect the correct voltage readings. The sensor outputs can be viewed using the combine display.

**NOTE:**

Changes may have been made to the combine controls or the display since this document was published. For the most up-to-date information, refer to the combine operator's manual.

**⚠ DANGER**

To prevent bodily injury or death from the unexpected start-up of the machine, always stop the engine and remove the key from the ignition before making adjustments to the machine.

**⚠ DANGER**

Ensure that all bystanders have cleared the area.

1. Position the header so that the cutterbar is 254–356 mm (10–14 in.) off the ground.
2. Shut down the engine, and remove the key from the ignition.
3. Unlock the header float. For instructions, refer to [Locking / Unlocking Header Float, page 221](#).
4. Lock the header wings. For instructions, refer to [Operating in Rigid Mode, page 224](#).

**⚠ CAUTION**

To prevent cuts, pinches, and other bodily harm to the person checking the down stops, ensure that nobody is manually lifting, bouncing, or moving the header in any way while the down stop washer is being touched and checked for movement.

5. Ensure that the float lock linkage is on the down stops (washer [A] cannot move) at both locations.

**NOTE:**

If the header is **NOT** on the down stops, the voltage may go out of range during operation and cause the AHHC system to malfunction. To fix the problem, make the header heavier by decreasing the float. For instructions, refer to [Checking and Adjusting Header Float, page 210](#).

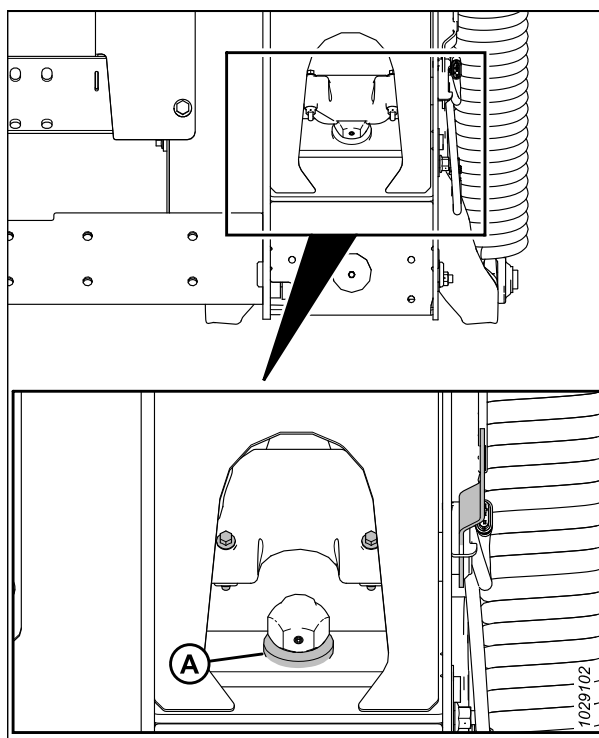


Figure 3.464: Down Stop Washer

## AUTO HEADER HEIGHT CONTROL SYSTEM

6. If the pointer is not on zero, loosen bolt (A) and rotate float indicator plate (B) until pointer (C) is on **0** (D). Tighten the nut on bolt (A).

**NOTE:**

Use zero dot (E) above the decal to correctly set the indicator needle.

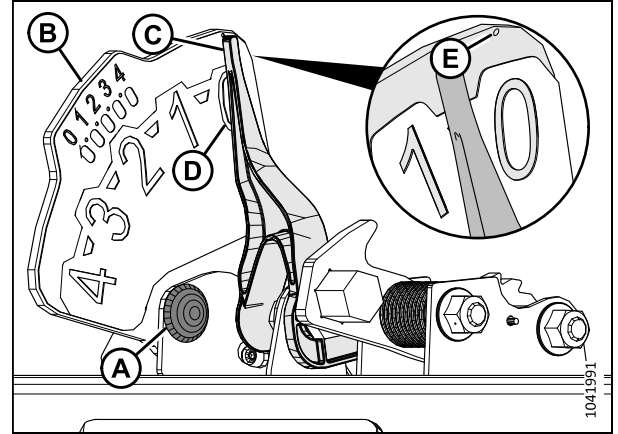


Figure 3.465: Float Indicator

7. Ensure the header float is unlocked.
8. Select **DIAGNOSTICS** (A) on the **MAIN** page. The **DIAGNOSTICS** page opens.
9. Select **SETTINGS**. The **SETTINGS** page opens.

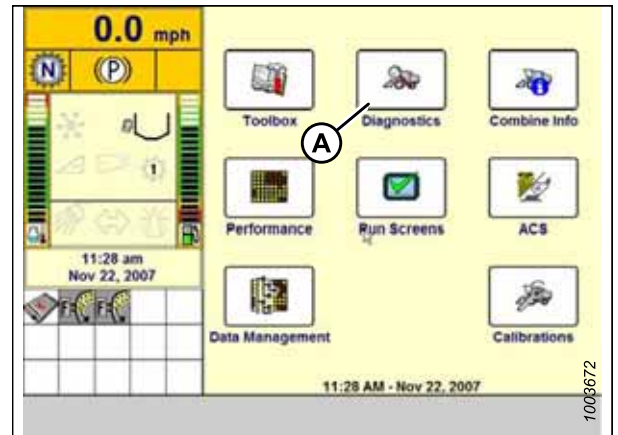


Figure 3.466: Case IH Combine Display

10. Select **GROUP** drop-down menu (A). The **GROUP** dialog box opens.

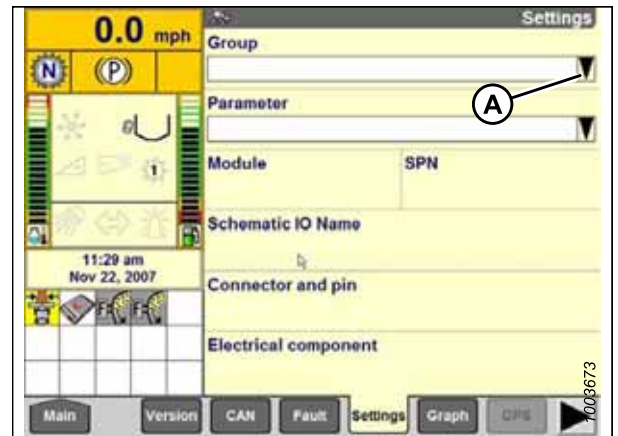


Figure 3.467: Case IH Combine Display



## AUTO HEADER HEIGHT CONTROL SYSTEM

11. Select HEADER HEIGHT/TILT (A). The PARAMETER page opens.

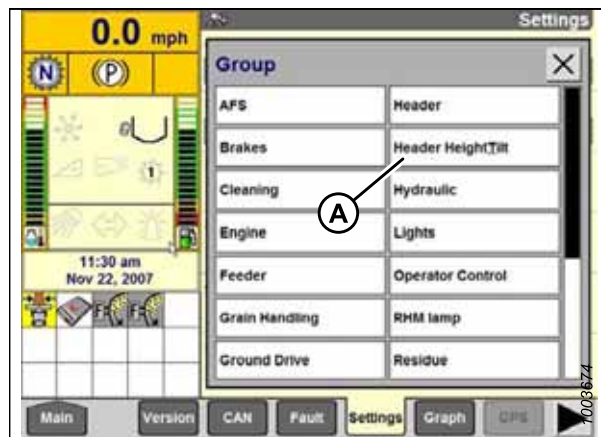


Figure 3.468: Case IH Combine Display

12. Select LEFT HEADER HEIGHT SEN (A), and then select GRAPH button (B). The exact voltage is displayed at top of page. Raise and lower the header to see the full range of voltage readings.

13. If the sensor voltage is not within the lower and upper limits, or if the range between the lower and upper limits is insufficient, refer to [3.3 Manually Checking Voltage Limits](#), page 296.

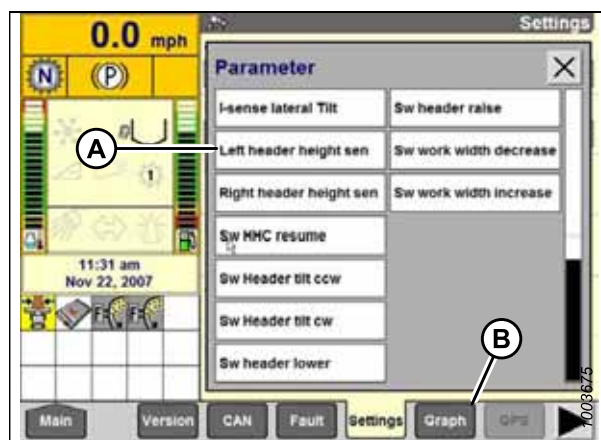


Figure 3.469: Case IH Combine Display

### 3.6.2 Header Settings Quick Reference – Case IH 120, 230, 240, and 250 Series

The recommended auto header height control (AHHC) settings for an FD2 Series FlexDraper® header operating with a Case IH 120, 230, 240, and 250 Series combine are provided.

**NOTE:**

The setting options vary based on the software version of the combine. For software version 28.00 or higher, refer to Table 3.40, page 314; for lower versions, refer to Table 3.41, page 315.

**Table 3.40 Header Settings – Case IH 120, 230, 240, and 250 Series (Software Version 28.00 or Higher)**

Setup Parameter	Suggested Setting
Header Sub Type	<ul style="list-style-type: none"> <li>If software version 36.4.X.X or later is installed: <b>FD2/D2 SERIES</b></li> <li>If a software version prior to version 36.4.X.X is installed: <b>2000</b></li> </ul>
Frame Type	FLEXHEAD
Header Sensors	ENABLE
Header Pressure Float	NO
Height/Tilt Response	FAST
Auto Height Override	YES

## AUTO HEADER HEIGHT CONTROL SYSTEM

**Table 3.40 Header Settings – Case IH 120, 230, 240, and 250 Series (Software Version 28.00 or Higher) (continued)**

Setup Parameter	Suggested Setting	
HHC Height Sensitivity <sup>76</sup>	Two-sensor system	250
	One-sensor system	180
HHC Tilt Sensitivity	150	
Reel Height Sensor	YES	
Autotilt	Two-sensor system	YES
	One-sensor system	NO

**Table 3.41 Header Settings – Case IH 120, 230, 240, and 250 Series (Below Software Version 28.00)**

Setup Parameter	Suggested Setting	
Header Style	FLEXHEAD	
Auto Reel Speed Slope	133	
Header Pressure Float	NO	
Reel Drive	HYDRAULIC	
Reel Fore-Back	YES	
HHC Height Sensitivity <sup>76</sup>	Two-sensor system	250
	One-sensor system	180
HHC Tilt Sensitivity	150	
Fore/Aft Control	YES	
HDR Fore/Aft Tilt	YES	
Header Type (HEAD2 tab)	DRAPER	
Cutting Type	PLATFORM	
Header Width	Set according to header specification	
Header Usage	Set according to header specification	
Reel Height Sensor	YES	
Autotilt	Two-sensor system	YES
	One-sensor system	NO

### 3.6.3 Calibrating Auto Header Height Control – Case IH 120, 230, 240, and 250 Series Combines with Software Version below 28.00

The auto header height control (AHHC) sensor output must be calibrated for each combine, or the AHHC feature will not work properly.

**NOTE:**

This procedure applies to combines with a software version below 28.00. For instructions on calibrating the AHHC for combines with software version 28.00 or above, refer to [3.6.4 Calibrating Auto Header Height Control – Case IH Combines with Version 28.00 or Higher Software, page 320](#).

 **DANGER**

**To prevent bodily injury or death from the unexpected start-up of the machine, always stop the engine and remove the key from the ignition before making adjustments to the machine.**

76. If hunting occurs during operation, decrease the HHC HEIGHT SENSITIVITY setting by 20 points at a time until hunting no longer occurs.

**⚠ DANGER**

Ensure that all bystanders have cleared the area.

**NOTE:**

Changes may have been made to the combine controls or the display since this document was published. For the most up-to-date information, refer to the combine operator's manual.

**NOTE:**

If the header float is set too light, it can prevent the calibration of the AHHC. In order to prevent the header from separating from the float module, it may be necessary to change the float to a heavier setting during calibration.

1. Park the combine on a level surface.
2. Ensure that the header is level with the ground. If adjustment is required:
  - Ensure that the combine is parked on a level surface.
  - If equipped, use the combine's lateral tilt to level the feeder house with the ground.
  - If further adjustment is required, shut the engine off, remove the key from the ignition, and ensure that the combine's tires are inflated to the correct pressure.

**NOTE:**

Spirit level (A) is located on top of the float module frame. The header is level if the bubble is in the center of the spirit level.

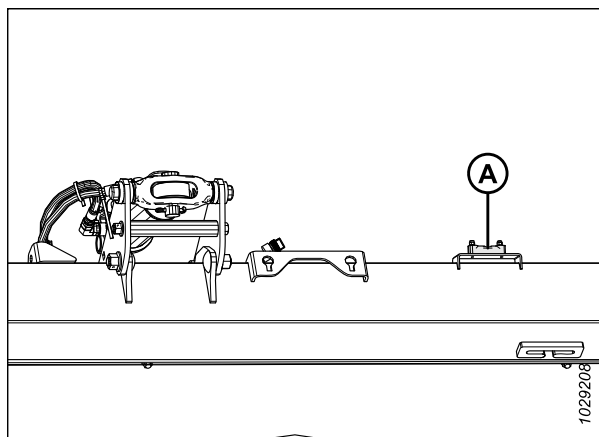


Figure 3.470: Spirit Level

3. Ensure that the center-link is set to **D**.

**NOTE:**

When calibration is complete, adjust the center-link back to the desired header angle. For instructions, refer to [3.9.5 Header Angle, page 232](#).

4. Adjust the reel fore-aft position so that the indicator is at position **6**.
5. Position the header so that the cutterbar is 254–356 mm (10–14 in.) off the ground.
6. Shut down the engine, and remove the key from the ignition.



## AUTO HEADER HEIGHT CONTROL SYSTEM

### CAUTION

To prevent cuts, pinches, and other bodily harm to the person checking the down stops, ensure that nobody is manually lifting, bouncing, or moving the header in any way while the down stop washer is being touched and checked for movement.

7. Ensure that the float lock linkage is on the down stops (washer [A] cannot move) at both locations.

#### NOTE:

If the header is **NOT** on the down stops, the voltage may go out of range during operation and cause the AHHC system to malfunction. To fix the problem, make the header heavier by decreasing the float. For instructions, refer to [Checking and Adjusting Header Float, page 210](#).

8. Unlock the header float. For instructions, refer to [Locking / Unlocking Header Float, page 221](#).
9. Lock the header wings. For instructions, refer to [Operating in Rigid Mode, page 224](#).

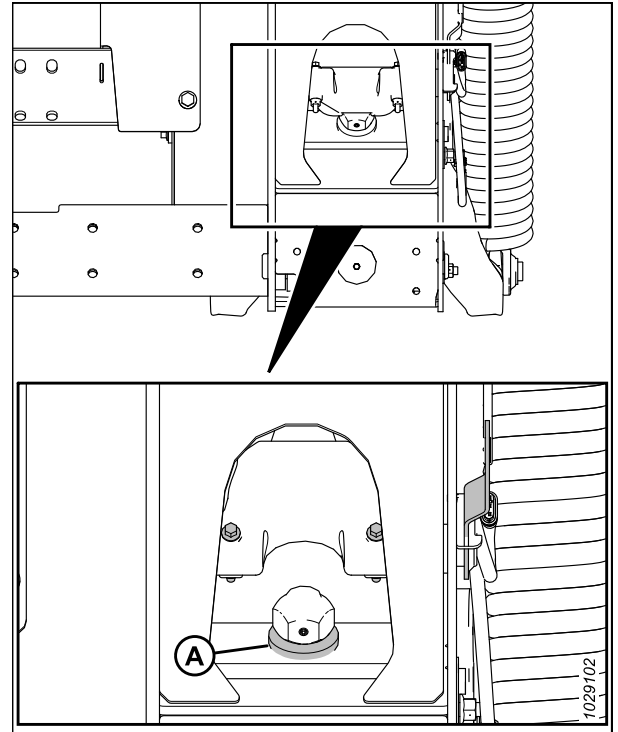


Figure 3.471: Down Stop Washer

10. Select TOOLBOX icon (A) on the main page.

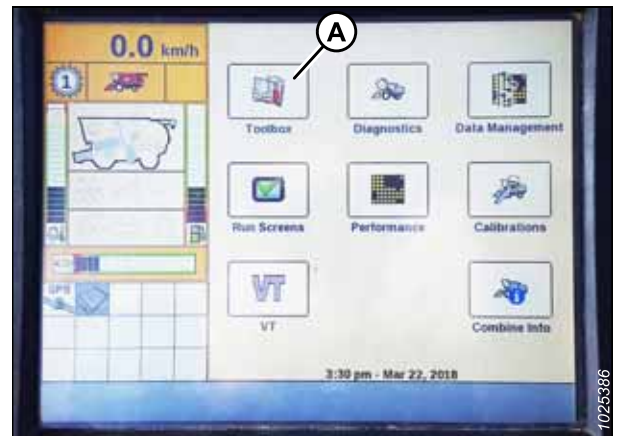


Figure 3.472: Case IH Combine Display

## AUTO HEADER HEIGHT CONTROL SYSTEM

11. Select HEADER tab (A).

**NOTE:**

To locate the HEADER tab, you may need to use side arrows (C).

12. Set HEADER STYLE (B) to FLEXHEAD.

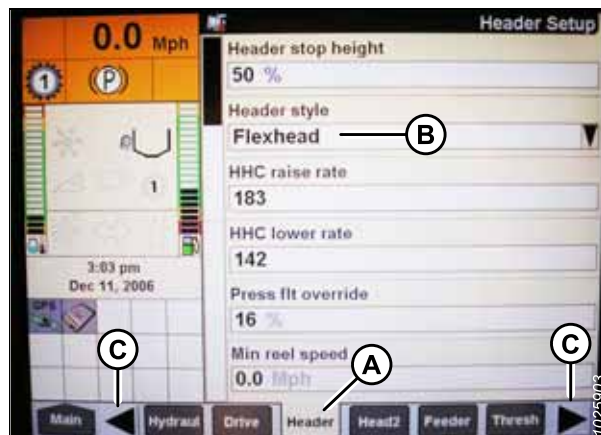


Figure 3.473: Case IH Combine Display

13. Set AUTO REELSPEED SLOPE.

**NOTE:**

The AUTO REELSPEED SLOPE value automatically maintains the speed of the reel relative to ground speed. For example, if the value is set to 133, then the reel's rotational speed will be higher than the combine's ground speed. In general, the reel's speed should be higher than the combine's ground speed; however, adjust the value according to crop conditions.

14. Set HEADER PRESSURE FLOAT to NO. Ensure that REEL DRIVE is set to HYDRAULIC.



Figure 3.474: Case IH Combine Display

15. Set REEL FORE-BACK to YES (if applicable).

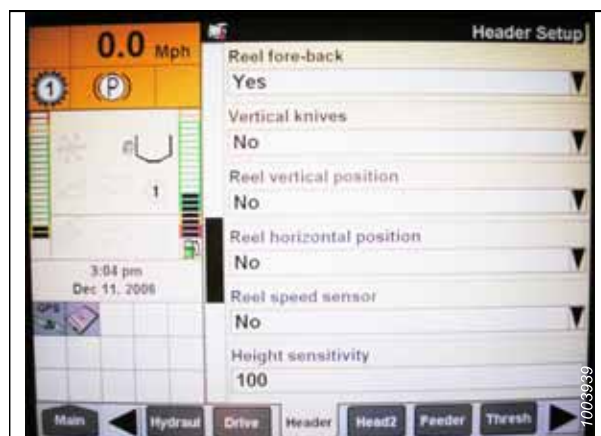


Figure 3.475: Case IH Combine Display

## AUTO HEADER HEIGHT CONTROL SYSTEM

16. Locate HHC HEIGHT SENSITIVITY field (A), and set it as follows:

- **Two-sensor systems:** Set HHC HEIGHT SENSITIVITY to 250.
- **Single-sensor systems:** Set HHC HEIGHT SENSITIVITY to 180.

**NOTE:**

If the combine continually raises and lowers the header during operation (a behavior termed “hunting”), decrease the HHC HEIGHT SENSITIVITY setting by 20 points at a time until hunting no longer occurs.

17. Set HHC TILT SENSITIVITY (B) to 150. Adjust the sensitivity as desired.

18. Set FORE/AFT CONTROL and HDR FORE/AFT TILT to YES (if applicable).



Figure 3.476: Case IH Combine Display

19. Press HEAD2 (A) at the bottom of the page.

20. Ensure that HEADER TYPE (B) is set to DRAPER.

**NOTE:**

If the recognition resistor is plugged in to the header harness, you will not be able to change this setting.

21. Set CUTTING TYPE (C) to PLATFORM.

22. Set HEADER WIDTH (D) and HEADER USAGE (E) to the appropriate values.

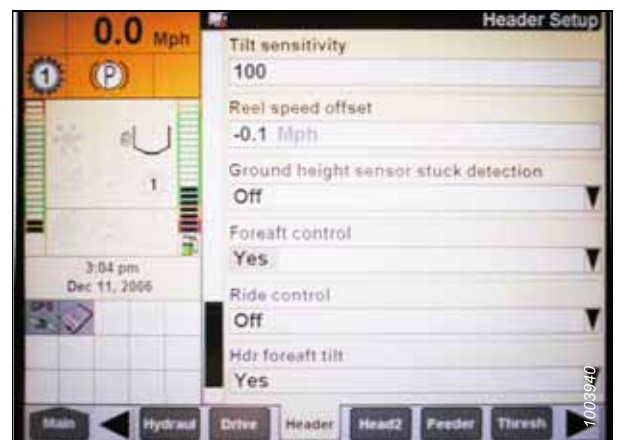


Figure 3.477: Case IH Combine Display

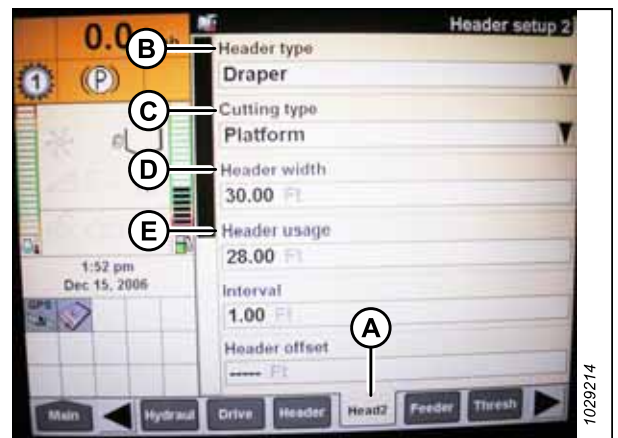


Figure 3.478: Case IH Combine Display

## AUTO HEADER HEIGHT CONTROL SYSTEM

23. From the REEL HEIGHT SENSOR menu, select YES (A).



Figure 3.479: Case IH Combine Display

24. Locate AUTOTILT field (A) and set it as follows:

- **Two-sensor system:** Select YES.
- **Single-sensor system:** Select NO.

### NOTE:

If the float was changed to a heavier setting to complete the AHHC calibration procedure, adjust it to the recommended operating float after calibration is complete.



Figure 3.480: Case IH Combine Display

### 3.6.4 Calibrating Auto Header Height Control – Case IH Combines with Version 28.00 or Higher Software

Calibrate the auto header height control (AHHC) sensor output for each combine.

#### DANGER

To prevent bodily injury or death from the unexpected start-up of the machine, always stop the engine and remove the key from the ignition before making adjustments to the machine.

#### DANGER

Ensure that all bystanders have cleared the area.

### NOTE:

Changes may have been made to the combine controls or the display since this document was published. For the most up-to-date information, refer to the combine operator's manual.

### NOTE:

If the header float is set too light, it can prevent the calibration of the AHHC. In order to prevent the header from separating from the float module, it may be necessary to change the float to a heavier setting during calibration.

## AUTO HEADER HEIGHT CONTROL SYSTEM

1. Park the combine on a level surface.
2. Ensure that the header is level with the ground. If adjustment is required:
  - Ensure that the combine is parked on a level surface.
  - If equipped, use the combine's lateral tilt to level the feeder house with the ground.
  - If further adjustment is required, shut the engine off, remove the key from the ignition, and ensure that the combine's tires are inflated to the correct pressure.

**NOTE:**

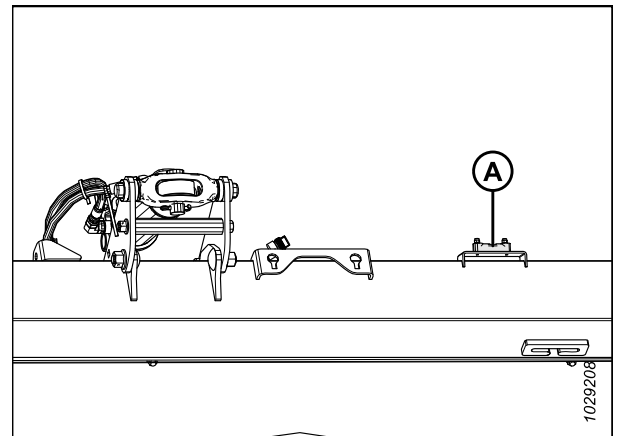
Spirit level (A) is located on top of the float module frame. The header is level if the bubble is in the center of the spirit level.

3. Ensure that the center-link is set to **D**.

**NOTE:**

When calibration is complete, adjust the center-link back to the desired header angle. For instructions, refer to [3.9.5 Header Angle, page 232](#).

4. Adjust the reel fore-aft position so that the indicator is at position **6**.
5. Position the header so that the cutterbar is 254–356 mm (10–14 in.) off the ground.
6. Shut down the engine, and remove the key from the ignition.



**Figure 3.481: Spirit Level**

## AUTO HEADER HEIGHT CONTROL SYSTEM

### CAUTION

To prevent cuts, pinches, and other bodily harm to the person checking the down stops, ensure that nobody is manually lifting, bouncing, or moving the header in any way while the down stop washer is being touched and checked for movement.

7. Ensure that the float lock linkage is on the down stops (washer [A] cannot move) at both locations.

#### NOTE:

If the header is **NOT** on the down stops, the voltage may go out of range during operation and cause the AHHC system to malfunction. To fix the problem, make the header heavier by decreasing the float. For instructions, refer to [Checking and Adjusting Header Float, page 210](#).

8. Unlock the header float. For instructions, refer to [Locking / Unlocking Header Float, page 221](#).
9. Lock the header wings. For instructions, refer to [Operating in Rigid Mode, page 224](#).

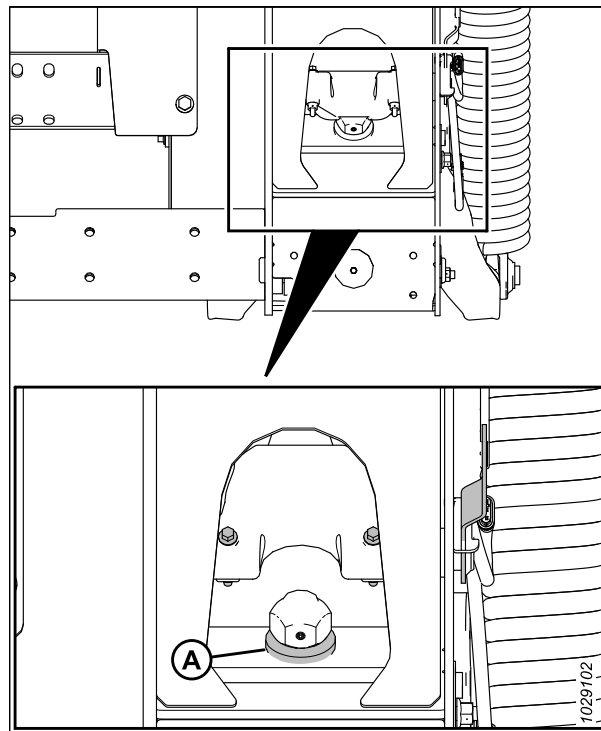


Figure 3.482: Down Stop Washer

10. To view the software version, select the DIAGNOSTICS button from the Home Screen, then select VERSION tab (A).
11. Ensure that the software version is **28.00 or higher**.

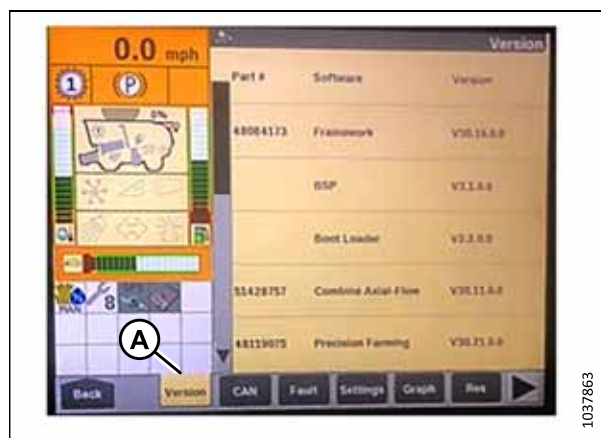


Figure 3.483: Case IH Combine Display



## AUTO HEADER HEIGHT CONTROL SYSTEM

### Adjusting combine display settings

12. Select TOOLBOX icon (A) on the MAIN page.

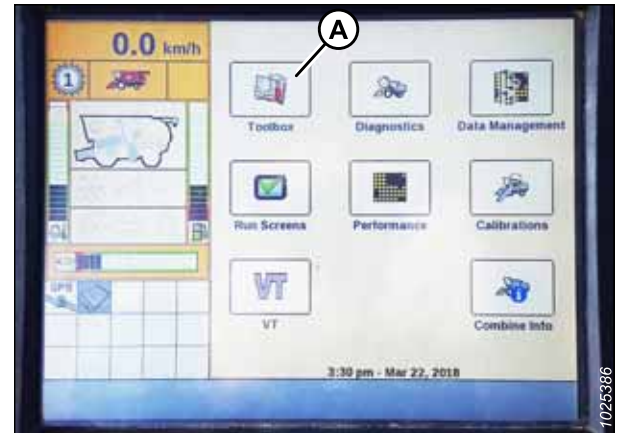


Figure 3.484: Case IH Combine Display

13. Select HEAD 1 tab (A).

#### NOTE:

To locate the HEAD 1 tab, you may need to use side arrows (B).

14. Locate HEADER SUB TYPE field (C).



Figure 3.485: Case IH Combine Display

15. Select the following value from the HEADER SUB TYPE field:

- If software version 36.4.X.X or later is installed, select FD2/D2 SERIES (A).

#### NOTE:

Selecting FD2/D2 SERIES will optimize AHHC performance on FD2 Series FlexDraper® Headers.

- If a software version prior to version 36.4.X.X is installed, select **2000** (B).

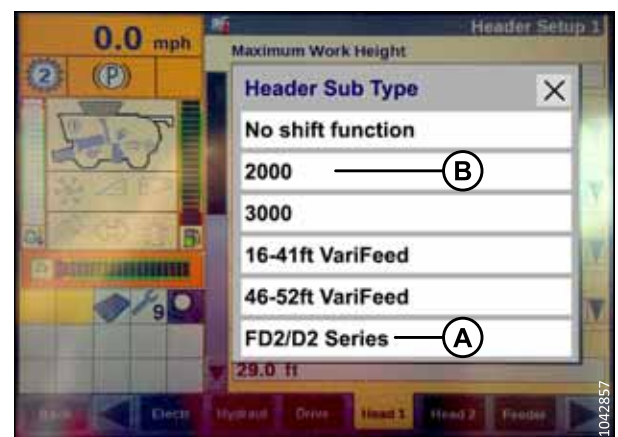


Figure 3.486: Case IH Combine Display

## AUTO HEADER HEIGHT CONTROL SYSTEM

16. Return to the HEAD 1 page and choose FLEXHEAD from FRAME TYPE drop-down menu (A).

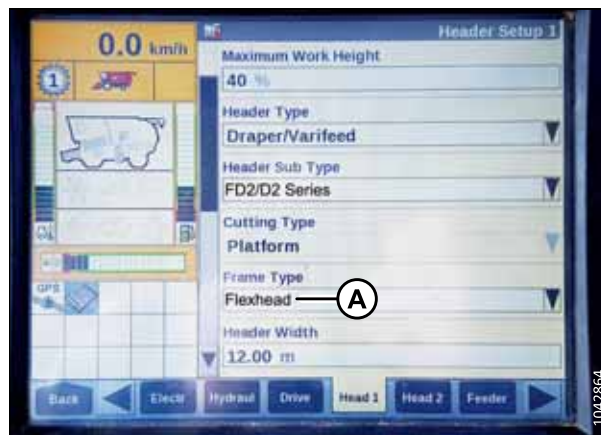


Figure 3.487: Case IH Combine Display

17. Select HEAD 2 tab (A).
18. In HEADER SENSORS field (B), select ENABLE.
19. In HEADER PRESSURE FLOAT field (C), select NO.
20. In HEIGHT/TILT RESPONSE field (D), select FAST.
21. In AUTO HEIGHT OVERRIDE field (E), select YES.
22. Press down arrow (F) to go to the next page.

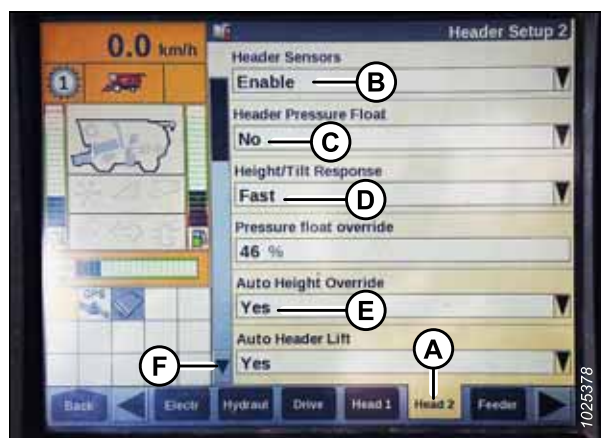


Figure 3.488: Case IH Combine Display

23. Locate HHC HEIGHT SENSITIVITY field (A), and set it as follows:

- **Single-sensor system:** Set HHC HEIGHT SENSITIVITY to 180.
- **Two-sensor system:** Set HHC HEIGHT SENSITIVITY to 250.

**NOTE:**

If the combine continually raises and lowers the header during operation (a behavior termed “hunting”), decrease the HHC HEIGHT SENSITIVITY setting by 20 points at a time until hunting no longer occurs.

24. Set HHC TILT SENSITIVITY (B) to 150. Adjust the sensitivity as desired.



Figure 3.489: Case IH Combine Display



## AUTO HEADER HEIGHT CONTROL SYSTEM

25. From the REEL HEIGHT SENSOR menu, select YES (A).



Figure 3.490: Case IH Combine Display

26. Scroll to the AUTOTILT field (A), and set it as follows:

- **Two-sensor system:** Select YES.
- **Single-sensor system:** Select NO.



Figure 3.491: Case IH Combine Display

### *Calibrating auto header height control*

27. Select CALIBRATION on the combine display and press the right arrow navigation key to enter the information box.

28. Select HEADER (A), and press ENTER. The CALIBRATION dialog box opens.

#### **NOTE:**

Use the UP and DOWN navigation keys to move between the different options.



Figure 3.492: Case IH Combine Display

## AUTO HEADER HEIGHT CONTROL SYSTEM

29. Follow the calibration steps as they appear. As you proceed through the calibration process, the display automatically updates to show the next step.

**NOTE:**

Pressing the ESC key during any of the steps or letting the system sit idle for over 3 minutes will stop the calibration procedure.

**NOTE:**

Refer to your combine operator's manual for an explanation of any error codes.

30. When all of the steps have been completed, CALIBRATION SUCCESSFUL displays on the page. Exit the CALIBRATION menu by pressing the ENTER or ESC key.

**NOTE:**

If the float was set heavier to complete calibration, adjust the header to the recommended operating float after calibration is complete.

31. Ensure that AUTO HEIGHT icon (A) appears on the monitor as shown at location (B). When the header is set for cutting on the ground, this verifies that the combine is correctly using the sensor on the header to detect the ground pressure.

**NOTE:**

Icons (A) and (B) appear on the monitor only after engaging the separator and header, and then pressing HEADER RESUME button on the control panel.

**NOTE:**

AUTO HEIGHT field (B) may appear on any of the RUN tabs and not necessarily on the RUN 1 tab.



Figure 3.493: Case IH Combine Display



Figure 3.494: Case IH Combine Display

### 3.6.5 Checking Reel Height Sensor Voltages – Case IH Combines

The voltage output of the reel height sensors can be inspected using the combine display in the cab.

#### DANGER

Ensure that all bystanders have cleared the area.

**NOTE:**

Changes may have been made to the combine controls or the display since this document was published. For the most up-to-date information, refer to the combine operator's manual.

## AUTO HEADER HEIGHT CONTROL SYSTEM

1. On the main page of the combine display, select DIAGNOSTICS (A). The DIAGNOSTICS page appears.

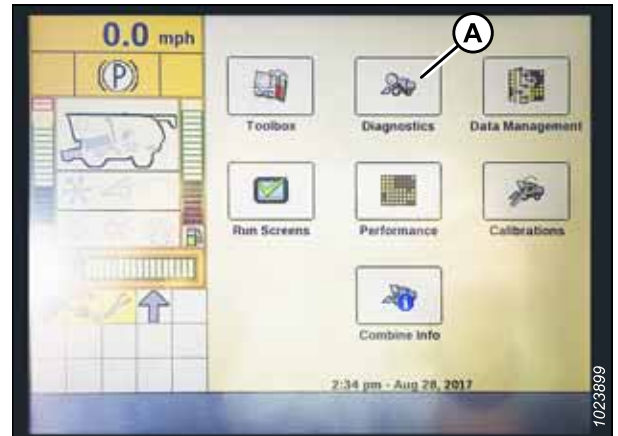


Figure 3.495: Case IH Combine Display

2. Select SETTINGS tab (A). The SETTINGS page appears.
3. From the GROUP menu, select HEADER (B).
4. From the PARAMETER menu, select REEL VERTICAL POSITION (C).



Figure 3.496: Case IH Combine Display

5. Select GRAPH tab (A). The REEL VERTICAL POSITION graph appears.
6. Lower the reel to view upper voltage (B). The voltage should be within 4.1–4.3 V.
7. Raise the reel to view lower voltage (C). The voltage should be within 0.7–0.9 V.
8. If either voltage is out of range, refer to *Checking and Adjusting Reel Height Sensor, page 248*.

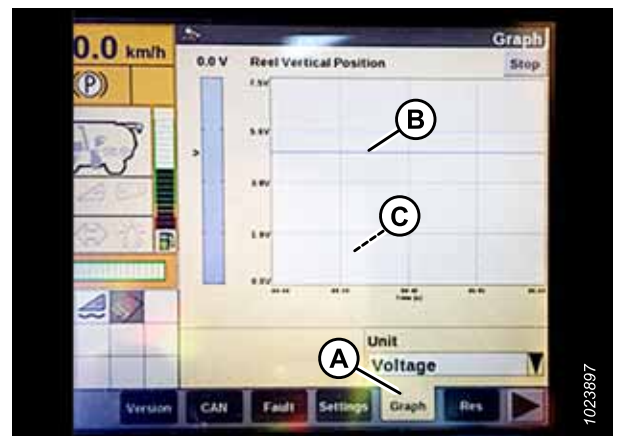


Figure 3.497: Case IH Combine Display

### 3.6.6 Setting Preset Cutting Height – Case IH 120, 230, 240, and 250 Series Combines

Once the auto header height control (AHHC) system has been configured to work with the header, the preset cutting height can be configured. The preset cutting height refers to the header height that the AHHC system will attempt to maintain as the combine moves forward.

**⚠ DANGER**

Ensure that all bystanders have cleared the area.

**NOTE:**

Changes may have been made to the combine controls or the display since this document was published. For the most up-to-date information, refer to the combine operator’s manual.

**NOTE:**

Indicator (A) should be at position 0 (B) with the header 254–356 mm (10–14 in.) off the ground. When the header is on the ground, the indicator should be at position 1 (C) for low ground pressure, and at position 4 (D) for high ground pressure. The crop and soil conditions determine the amount of float to use. The ideal setting is as light as possible without the header bouncing or missing crop. Operating with heavy settings prematurely wears the cutterbar wearplates.

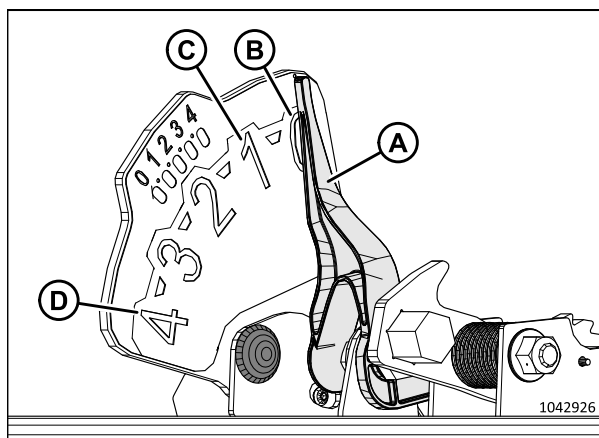


Figure 3.498: Float Indicator

1. Engage the separator and the header.
2. Move the header to a desired cutting height.
3. Press SET #1 switch (A). The light beside switch (A) will light up.

**NOTE:**

Use switch (C) for fine adjustments.

**NOTE:**

When setting the presets, always set the header position before setting the reel position. If the header and the reel are set at the same time, the reel setting will not be saved.

4. Move the reel to the desired working position.
5. Press SET #1 switch (A). The light beside switch (A) will light up.
6. Move the header to a second desired cutting height.
7. Press SET #2 switch (B). The light beside switch (B) will light up.
8. Move the reel to a second desired working position.



Figure 3.499: Case Combine Controls

## AUTO HEADER HEIGHT CONTROL SYSTEM

9. Press SET #2 switch (B). The light beside switch (B) will light up.
10. To swap between the set points, press HEADER RESUME (A).
11. To raise the header, hold SHIFT button (B) behind the control handle and press HEADER RESUME switch (A). To lower the header, press HEADER RESUME switch (A). once to return to the header preset height.

### NOTE:

Pressing HEADER RAISE/LOWER switches (C) and (D) disengages AUTO HEIGHT mode. Press HEADER RESUME (A) to re-engage AUTO HEIGHT mode.



Figure 3.500: Case Combine Controls

### 3.6.7 Reel Reverse Function – Case IH Combines

With the installation of Case kit 91826802, Case IH Flagship combines can allow the reel to reverse with the feeder house.

#### DANGER

Ensure that all bystanders have cleared the area.

### NOTE:

Changes may have been made to the combine controls or the display since this document was published. For the most up-to-date information, refer to the combine operator's manual.

1. Select TOOLBOX (A) on the MAIN page.

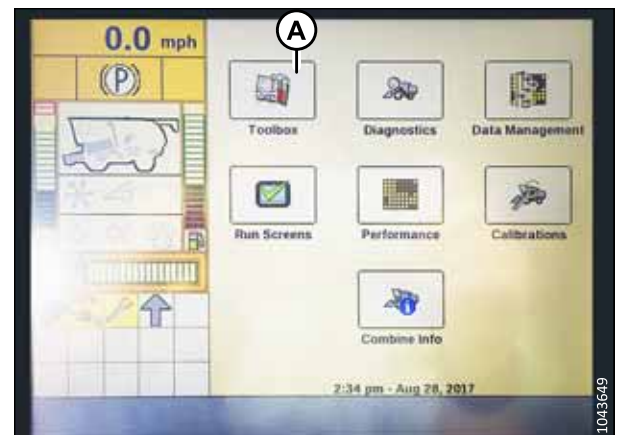


Figure 3.501: Case IH Combine Display



## AUTO HEADER HEIGHT CONTROL SYSTEM

2. Select HEAD 1 tab (A).

**NOTE:**

To locate the HEAD 1 tab, you may need to use side arrows (B).

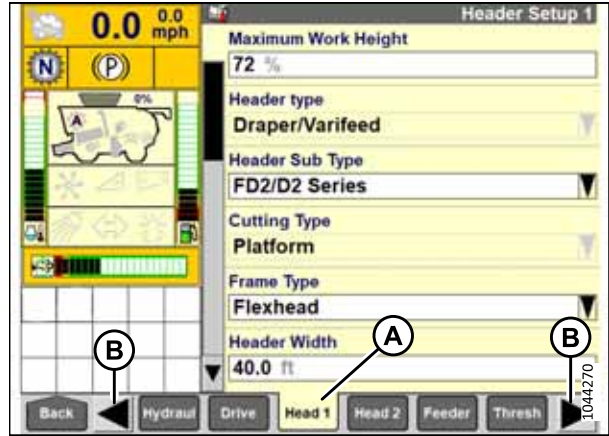


Figure 3.502: Case IH Combine Display

3. Locate the HEADER SUB TYPE field.
4. Select the following value from the HEADER SUB TYPE field:

- If software version 36.4.X.X or later is installed, select FD2/D2 SERIES (A).

**NOTE:**

Selecting FD2/D2 SERIES will optimize AHHC performance on FD2 Series FlexDraper® Headers.

- If a software version prior to version 36.4.X.X is installed, select **2000** (B).



Figure 3.503: Case IH Combine Display

5. Return to the HEAD 1 page and choose FLEXHEAD from FRAME TYPE drop-down menu (A).

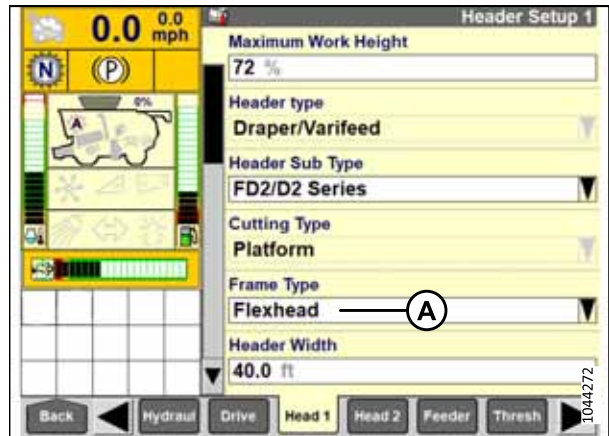


Figure 3.504: Case IH Combine Display

## AUTO HEADER HEIGHT CONTROL SYSTEM

6. Select HEAD 2 tab (A).
7. In HEADER SENSORS field (B), select ENABLE.
8. In HEADER PRESSURE FLOAT field (C), select NO.
9. In HEIGHT/TILT RESPONSE field (D), select FAST.

**NOTE:**

AUTO HEADER LIFT field (E) can be set to the user's preference.

10. Press down arrow (F) to go to the next page.



Figure 3.505: Case IH Combine Display

11. In HYDRAULIC REEL field (A), select YES.
12. In HYDRAULIC REEL REVERSE field (B), select YES.



Figure 3.506: Case IH Combine Display

13. In OVERLAP MODE field (A), select MANUAL.
14. In WORK WIDTH RESET field (B), select MANUAL.

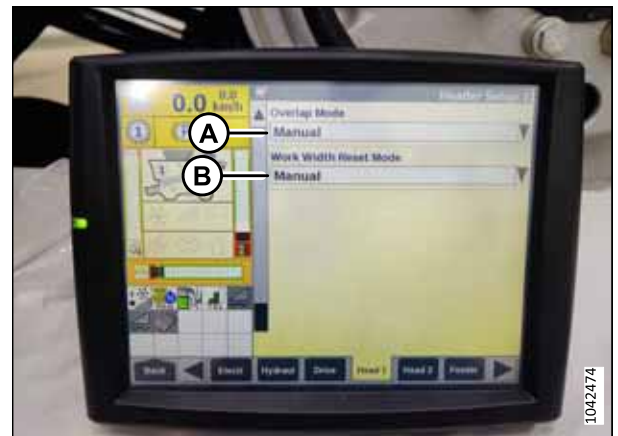


Figure 3.507: Case IH Combine Display

### 3.6.8 Side Draper Speed Control – Case IH Combines

The lateral belt speed can be adjusted on the touch screen display, for software version 34 and later.

#### DANGER

Ensure that all bystanders have cleared the area.

#### NOTE:

Changes may have been made to the combine controls or the display since this document was published. For the most up-to-date information, refer to the combine operator's manual.

1. Select HEAD 1 tab (A).

#### NOTE:

To locate the HEAD 1 tab, you may need to use side arrows (B).

2. Locate HEADER SUB TYPE field (C).

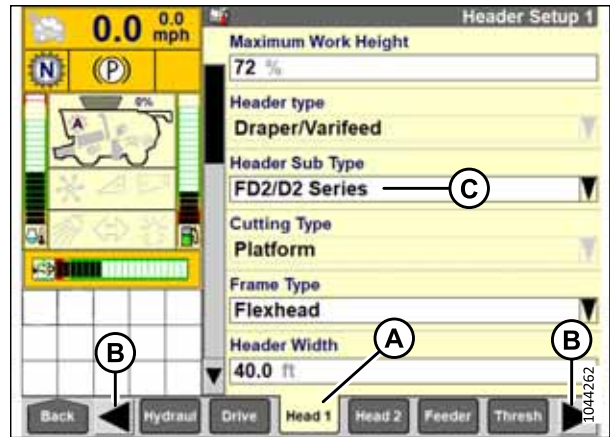


Figure 3.508: Case IH Combine Display

3. Select the following from the HEADER SUB TYPE field:

- If software version 36.4.X.X or later is installed, select FD2/D2 SERIES (A).

#### NOTE:

Selecting FD2/D2 SERIES will optimize AHHC performance on FD2 Series FlexDraper® Headers.

- If a software version prior to version 36.4.X.X is installed, select 2000 (B).

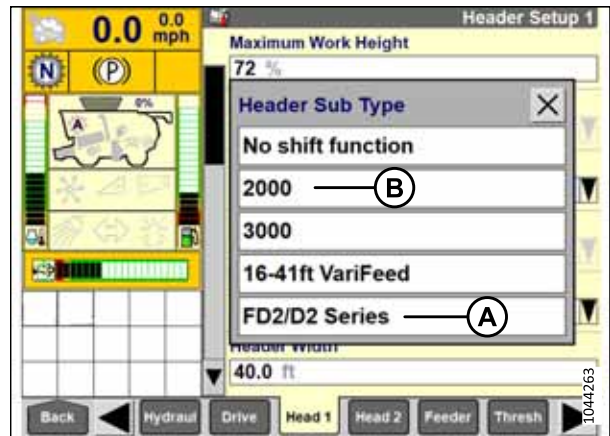


Figure 3.509: Case IH Combine Display



## AUTO HEADER HEIGHT CONTROL SYSTEM

- Use scrollbar (A) to navigate down to LATERAL BELT SPD (B).

**NOTE:**

The lateral belt speed can be adjusted using side arrows (C). Select ENTER (D) after adjusting the belt speed.

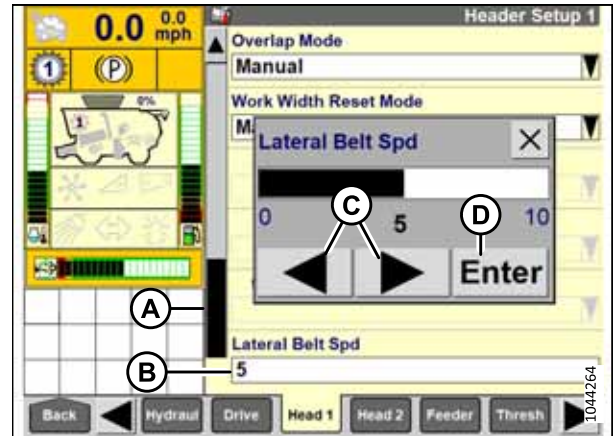


Figure 3.510: Case IH Combine Display

- Navigate to RUN4 tab (A).
- In WORK CONDITION field (B), select AUTO-DEFAULT.

**NOTE:**

The lateral belt speed can be adjusted by selecting LATERAL BELT SPD field (C).

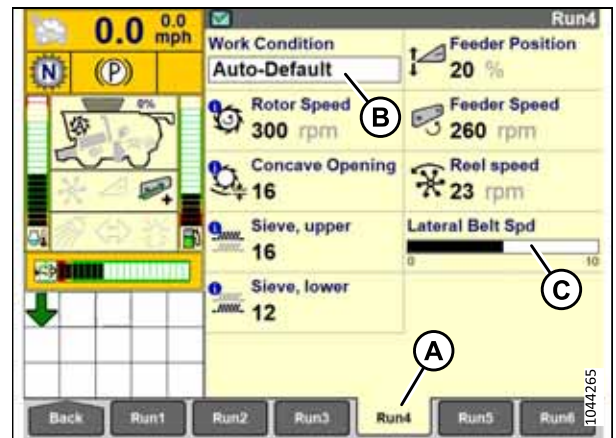


Figure 3.511: Case IH Combine Display

### 3.6.9 Reel Speed Sensor Compatibility – Case IH Combines

The reel speed settings can be adjusted using the touch screen display, for software version 34 and later.

**⚠ DANGER**

Ensure that all bystanders have cleared the area.

**NOTE:**

Changes may have been made to the combine controls or the display since this document was published. For the most up-to-date information, refer to the combine operator's manual.

## AUTO HEADER HEIGHT CONTROL SYSTEM

1. Select HEAD 2 tab (A).

**NOTE:**

To locate the HEAD 2 tab, you may need to use side arrows (C).

2. In REEL SPEED SENSOR field (B), select YES.

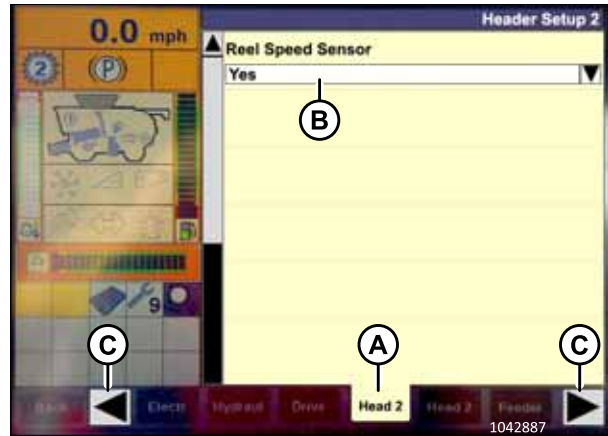


Figure 3.512: Case IH Combine Display

3. Select HEAD 2 tab (A).

4. Locate REEL SPROCKETS RATIO field (B), and select the appropriate sprocket ratio.

**NOTE:**

Sprocket ratio 19/56 is the default setting, while sprocket ratios 10/56 and 20/52 are optional settings.

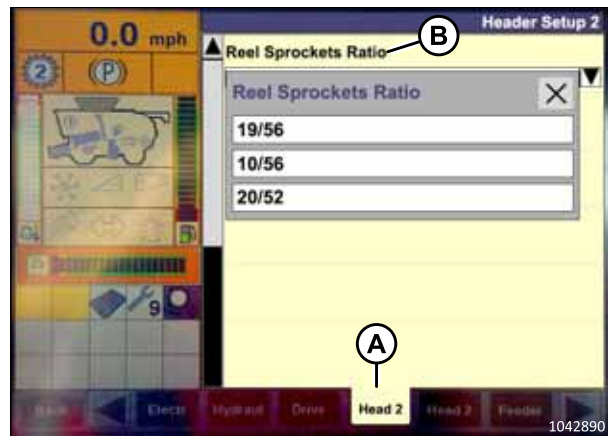


Figure 3.513: Case IH Combine Display

### 3.7 Challenger® and Massey Ferguson® 6 and 7 Series Combines

To make your header's auto header height control (AHHC) system compatible with the combine, configure the reel speed settings, set up the AHHC controls, and calibrate the AHHC system to ensure that it is working correctly.

#### 3.7.1 Checking Voltage Range from Combine Cab – Challenger® and Massey Ferguson®

The auto header height control sensor needs to operate within a specific voltage range in order to work properly.

**NOTE:**

Changes may have been made to the combine controls or the display since this document was published. For the most up-to-date information, refer to the combine operator's manual.

**! DANGER**

To prevent bodily injury or death from the unexpected start-up of the machine, always stop the engine and remove the key from the ignition before making adjustments to the machine.

**! DANGER**

Ensure that all bystanders have cleared the area.

1. Position the header so that the cutterbar is 254–356 mm (10–14 in.) off the ground.
2. Shut down the engine, and remove the key from the ignition.
3. Unlock the header float. For instructions, refer to *Locking / Unlocking Header Float, page 221*.
4. Lock the header wings. For instructions, refer to *Operating in Rigid Mode, page 224*.

**! CAUTION**

To prevent cuts, pinches, and other bodily harm to the person checking the down stops, ensure that nobody is manually lifting, bouncing, or moving the header in any way while the down stop washer is being touched and checked for movement.

5. Ensure that the float lock linkage is on the down stops (washer [A] cannot move) at both locations.

**NOTE:**

If the header is **NOT** on the down stops, the voltage may go out of range during operation and cause the AHHC system to malfunction. To fix the problem, make the header heavier by decreasing the float. For instructions, refer to *Checking and Adjusting Header Float, page 210*.

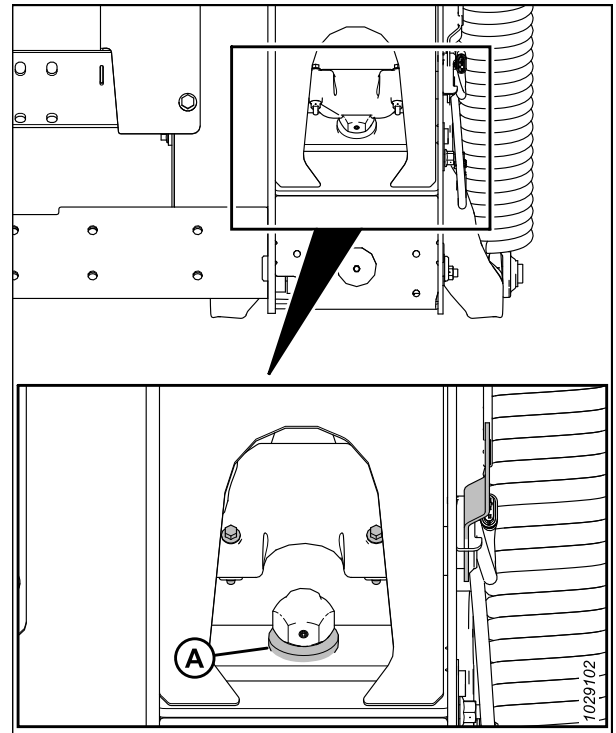


Figure 3.514: Down Stop Washer

## AUTO HEADER HEIGHT CONTROL SYSTEM

- If the pointer is not on zero, loosen bolt (A) and rotate float indicator plate (B) until pointer (C) is on 0 (D). Tighten the nut on bolt (A).

**NOTE:**

Use zero dot (E) above the decal to correctly set the indicator needle.

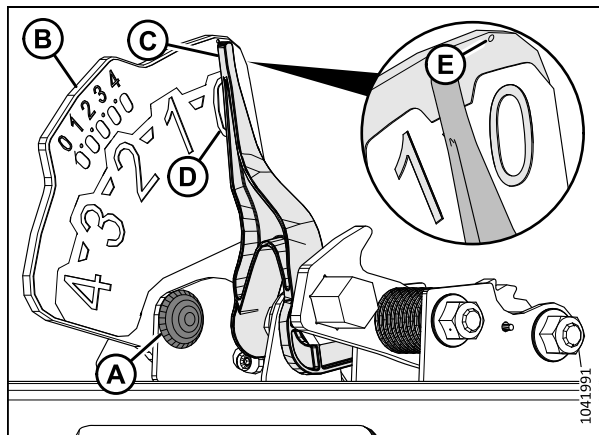


Figure 3.515: Float Indicator

- Go to the FIELD page on the combine monitor, and then press the diagnostics icon. The MISCELLANEOUS page appears.
- Select VMM DIAGNOSTIC (A). The VMM DIAGNOSTIC page appears.



Figure 3.516: Challenger® Combine Display

- Go to ANALOG IN tab (A), and then select VMM MODULE 3 by selecting the text box below the four tabs. The voltage from the AHC sensor is now displayed on the page as HEADER HEIGHT RIGHT POT and HEADER HEIGHT LEFT POT. The readings may be slightly different.



Figure 3.517: Challenger® Combine Display

## AUTO HEADER HEIGHT CONTROL SYSTEM

10. Fully lower the combine feeder house (the float module should be fully separated from the header).

**NOTE:**

You may need to hold the HEADER DOWN switch for a few seconds to fully lower the feeder house.

11. Read the voltage.
12. Raise the header 254–356 mm (10–14 in.) above the ground, and unlock the float.
13. Read the voltage.
14. If the sensor voltage is not within the lower and upper limits, or if the range between the lower and upper limits is insufficient, refer to [3.3 Manually Checking Voltage Limits](#), page 296.



Figure 3.518: Challenger® Combine Display

### 3.7.2 Engaging Auto Header Height Control – Challenger® and Massey Ferguson®

The auto header height control (AHHC) system must be engaged before its features can be configured.

**NOTE:**

Changes may have been made to the combine controls or the display since this document was published. For the most up-to-date information, refer to the combine operator’s manual.

The following system components are required in order for the AHHC to work:

- Main module (PCB board) and header driver module (PCB board) mounted in the card box in the fuse panel module (FP)
- Multifunction control handle operator inputs
- Operator inputs mounted in the control console module (CC) panel
- The electrohydraulic header lift control valve

To engage the AHHC, follow these steps:

1. Scroll through the header control options on the combine display using the header control switch until AHHC icon (A) is displayed in the first message box. The AHHC will adjust the header height in relation to the ground according to the height setting and sensitivity setting.



Figure 3.519: Challenger® Combine Display

### 3.7.3 Calibrating Auto Header Height Control – Challenger® and Massey Ferguson®

The auto header height control (AHHC) sensor output must be calibrated for each combine.

#### DANGER

To prevent bodily injury or death from the unexpected start-up of the machine, always stop the engine and remove the key from the ignition before making adjustments to the machine.

#### DANGER

Ensure that all bystanders have cleared the area.

#### NOTE:

Changes may have been made to the combine controls or the display since this document was published. For the most up-to-date information, refer to the combine operator's manual.

#### NOTE:

If the header float is set too light, it can prevent the calibration of the AHHC. In order to prevent the header from separating from the float module, it may be necessary to change the float to a heavier setting during calibration.

1. Park the combine on a level surface.
2. Ensure that the header is level with the ground. If adjustment is required:
  - Ensure that the combine is parked on a level surface.
  - If equipped, use the combine's lateral tilt to level the feeder house with the ground.
  - If further adjustment is required, shut the engine off, remove the key from the ignition, and ensure that the combine's tires are inflated to the correct pressure.

#### NOTE:

Spirit level (A) is located on top of the float module frame. The header is level if the bubble is in the center of the spirit level.

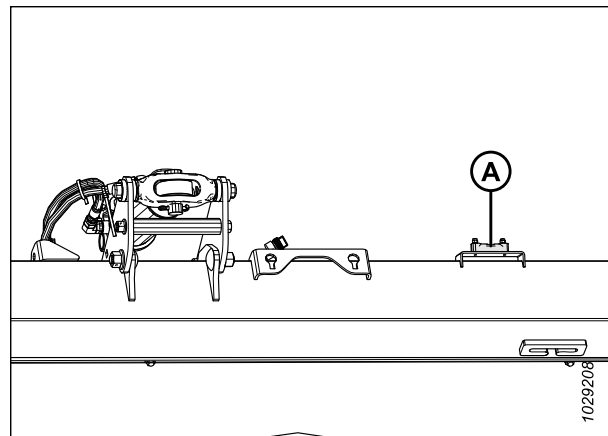


Figure 3.520: Spirit Level

3. Ensure that the center-link is set to **D**.

#### NOTE:

When calibration is complete, adjust the center-link back to the desired header angle. For instructions, refer to [3.9.5 Header Angle, page 232](#).

4. Adjust the reel fore-aft position so that the indicator is at position **6**.
5. Position the header so that the cutterbar is 254–356 mm (10–14 in.) off the ground.
6. Shut down the engine, and remove the key from the ignition.



## AUTO HEADER HEIGHT CONTROL SYSTEM

### CAUTION

To prevent cuts, pinches, and other bodily harm to the person checking the down stops, ensure that nobody is manually lifting, bouncing, or moving the header in any way while the down stop washer is being touched and checked for movement.

7. Ensure that the float lock linkage is on the down stops (washer [A] cannot move) at both locations.

#### NOTE:

If the header is **NOT** on the down stops, the voltage may go out of range during operation and cause the AHHC system to malfunction. To fix the problem, make the header heavier by decreasing the float. For instructions, refer to [Checking and Adjusting Header Float, page 210](#).

8. Unlock the header float. For instructions, refer to [Locking / Unlocking Header Float, page 221](#).
9. Lock the header wings. For instructions, refer to [Operating in Rigid Mode, page 224](#).

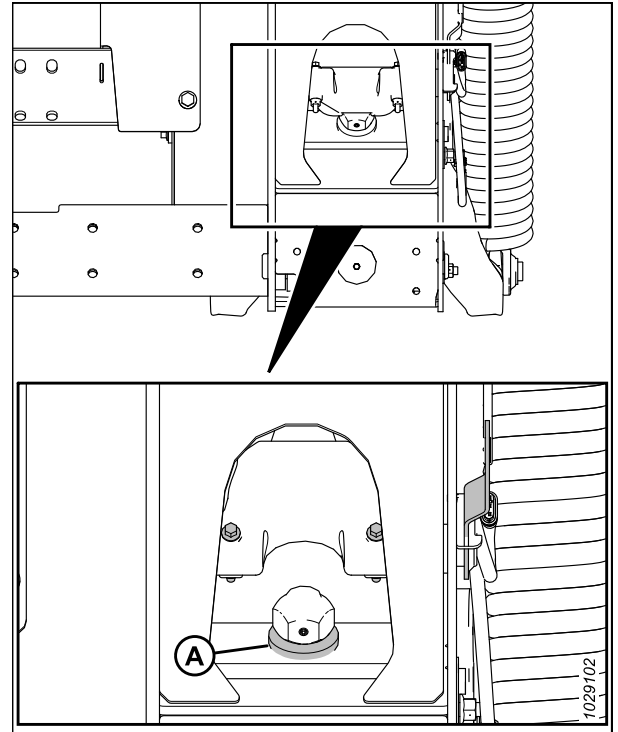


Figure 3.521: Down Stop Washer

10. On the FIELD page, select DIAGNOSTICS icon (A). The MISCELLANEOUS page appears.

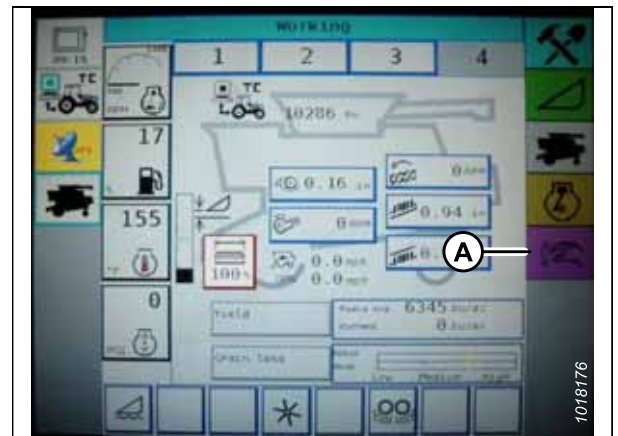


Figure 3.522: Challenger® Combine Display

## AUTO HEADER HEIGHT CONTROL SYSTEM

11. Select CALIBRATIONS (A). The CALIBRATIONS page appears.

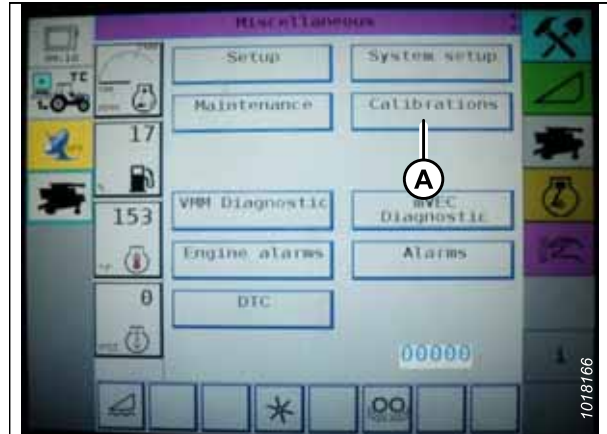


Figure 3.523: Challenger® Combine Display

12. Select HEADER (A). The HEADER CALIBRATION page displays a WARNING.

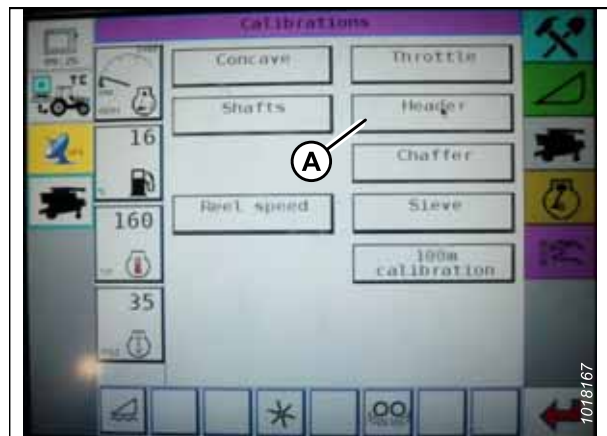


Figure 3.524: Challenger® Combine Display

13. Read the WARNING message, then select the green check mark button.



Figure 3.525: Challenger® Combine Display



14. Follow the on-screen prompts to complete calibration.

**NOTE:**

The calibration procedure can be canceled at any time by pressing the CANCEL button on the screen. While the header calibration is running, the calibration can also be canceled by using the UP, DOWN, TILT RIGHT, or TILT LEFT buttons on the control handle.

**NOTE:**

If the combine does not have HEADER TILT installed or if it is inoperable, you may receive warnings during calibration. Press the green check mark if these warnings appear. This will not affect calibration.

**NOTE:**

If the float was set heavier to complete the AHHC calibration procedure, adjust it to the recommended operating float after the calibration is complete.

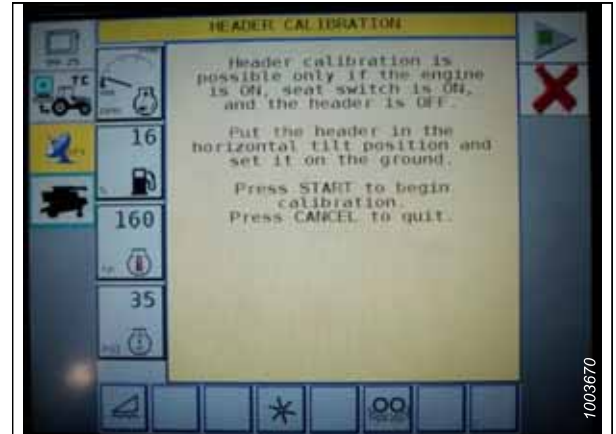


Figure 3.526: Challenger® Combine Display

### 3.7.4 Adjusting Header Height – Challenger® and Massey Ferguson®

The auto header height control (AHHC) feature allows the operator to set specific header heights.

**! DANGER**

Ensure that all bystanders have cleared the area.

**NOTE:**

Changes may have been made to the combine controls or the display since this document was published. For the most up-to-date information, refer to the combine operator's manual.

Once the AHHC is activated, press and release the HEADER LOWER button on the control handle. The AHHC will automatically lower the header to the selected height setting.

You can adjust the selected AHHC height using HEIGHT ADJUSTMENT knob (A) on the control console. Turning the knob clockwise increases the selected height, and turning the knob counterclockwise decreases the selected height.



Figure 3.527: Height Adjustment Knob on the Combine Control Console

### 3.7.5 Adjusting Header Raise/Lower Rate – Challenger® and Massey Ferguson®

The rate at which the header rises and falls can be configured by accessing the HEADER CONTROL menu on the combine display.

**NOTE:**

Changes may have been made to the combine controls or the display since this document was published. For the most up-to-date information, refer to the combine operator’s manual.

1. Select HEADER icon (A) on the FIELD page. The HEADER page appears.

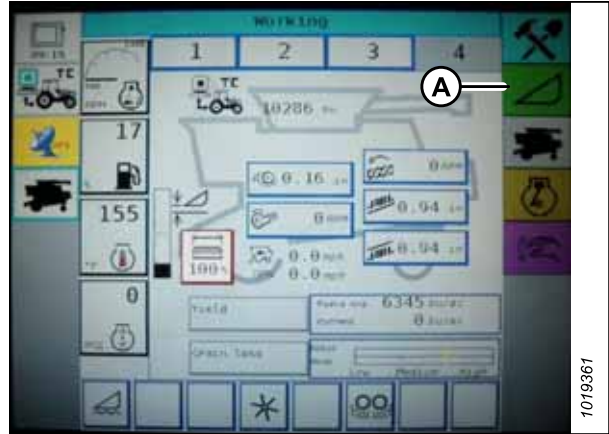


Figure 3.528: Challenger® Combine Display

2. Select HEADER CONTROL (A). The HEADER CONTROL page appears.

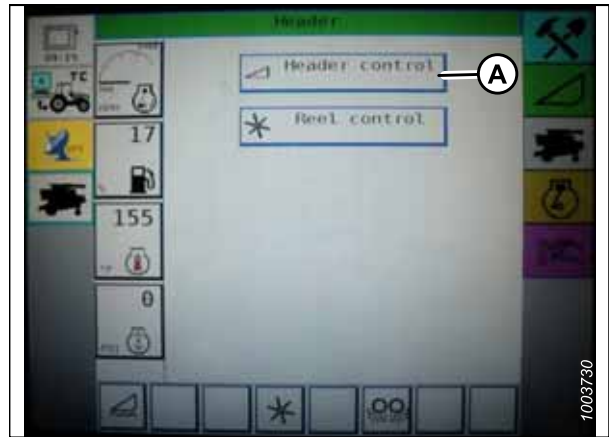


Figure 3.529: Challenger® Combine Display

## AUTO HEADER HEIGHT CONTROL SYSTEM

3. Go to the TABLE SETTINGS tab.
4. Select the up arrow on MAX UP PWM to increase the percentage number and increase the raise speed. Select the down arrow on MAX UP PWM to decrease the percentage number and decrease the raise speed.
5. Select the up arrow on MAX DOWN PWM to increase the percentage number and increase the lower speed. Select the down arrow on MAX DOWN PWM to decrease the percentage number and decrease the lower speed.

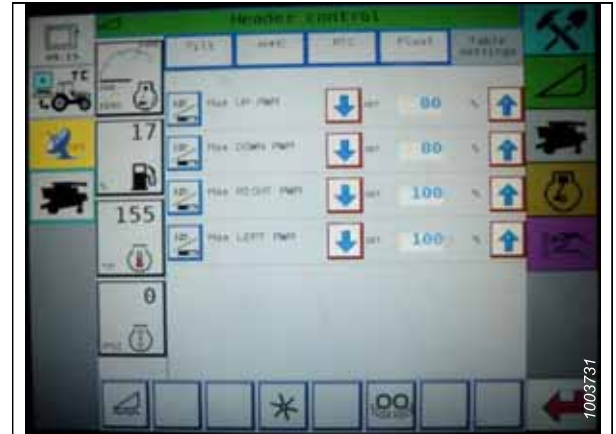


Figure 3.530: Challenger® Combine Display

### 3.7.6 Setting Auto Header Height Control Sensitivity – Challenger® and Massey Ferguson®

The sensitivity adjustment controls the distance that the cutterbar must travel before the auto header height control (AHC) raises or lowers the feeder house. When the sensitivity is set to maximum, only small changes in the ground height cause the AHC to move the feeder house. When the sensitivity is set to minimum, only large changes in the ground height cause the AHC to move the feeder house.

#### DANGER

Ensure that all bystanders have cleared the area.

#### NOTE:

Changes may have been made to the combine controls or the display since this document was published. For the most up-to-date information, refer to the combine operator's manual.

1. Select the HEADER icon on the FIELD page. The HEADER page appears.
2. Select HEADER CONTROL button (A). The HEADER CONTROL page appears. You can adjust the sensitivity on this page by using the up and down arrows.

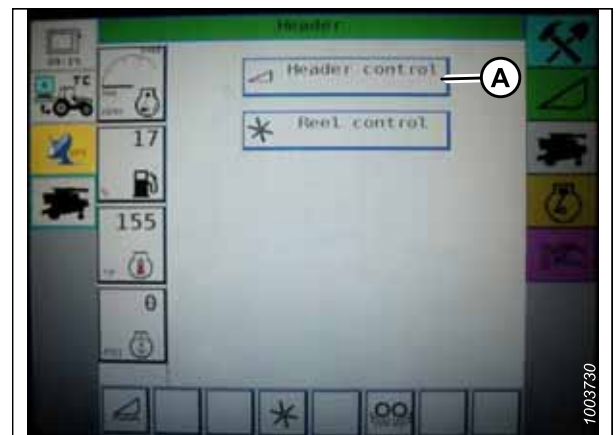


Figure 3.531: Challenger® Combine Display

## AUTO HEADER HEIGHT CONTROL SYSTEM

3. Adjust the sensitivity to the maximum setting.
4. Activate the AHHC, and press the HEADER LOWER button on the control handle.
5. Decrease the sensitivity until the feeder house remains steady and does not bounce up and down.

**NOTE:**

This is the maximum sensitivity and it is only an initial setting. The final setting must be made in the field, as the system reaction will vary with changing surfaces and operating conditions.

**NOTE:**

If maximum sensitivity is not needed, a less sensitive setting will reduce the frequency of header height corrections and component wear. Partially opening the accumulator valve will cushion the action of the header lift cylinders and reduce header hunting.



Figure 3.532: Challenger® Combine Display

## 3.8 CLAAS/CAT Lexion 500 Series and Model 600 Combines

To make your header's auto header height control (AHHC) system compatible with the combine, configure the reel speed settings, set up the AHHC controls, and calibrate the AHHC system to ensure that it is working correctly.

### 3.8.1 Calibrating Auto Header Height Control – CLAAS/CAT Lexion 500 series and model 600 combines

The auto header height control (AHHC) sensor output must be calibrated for each combine.

#### DANGER

To prevent bodily injury or death from the unexpected start-up of the machine, always stop the engine and remove the key from the ignition before making adjustments to the machine.

#### DANGER

Ensure that all bystanders have cleared the area.

#### NOTE:

Changes may have been made to the combine controls or the display since this document was published. For the most up-to-date information, refer to the combine operator's manual.

#### NOTE:

If the header float is set too light, it can prevent the calibration of the AHHC. In order to prevent the header from separating from the float module, it may be necessary to change the float to a heavier setting during calibration.

1. Park the combine on a level surface.
2. Ensure that the header is level with the ground. If adjustment is required:
  - Ensure that the combine is parked on a level surface.
  - If equipped, use the combine's lateral tilt to level the feeder house with the ground.
  - If further adjustment is required, shut the engine off, remove the key from the ignition, and ensure that the combine's tires are inflated to the correct pressure.

#### NOTE:

Spirit level (A) is located on top of the float module frame. The header is level if the bubble is in the center of the spirit level.

3. Ensure that the center-link is set to **D**.

#### NOTE:

When calibration is complete, adjust the center-link back to the desired header angle. For instructions, refer to [3.9.5 Header Angle, page 232](#).

4. Adjust the reel fore-aft position so that the indicator is at position **6**.
5. Position the header so that the cutterbar is 254–356 mm (10–14 in.) off the ground.

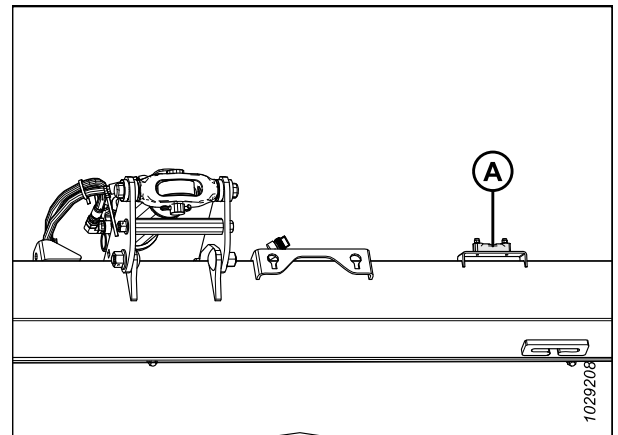


Figure 3.533: Spirit Level

## AUTO HEADER HEIGHT CONTROL SYSTEM

6. Shut down the engine, and remove the key from the ignition.

### CAUTION

To prevent cuts, pinches, and other bodily harm to the person checking the down stops, ensure that nobody is manually lifting, bouncing, or moving the header in any way while the down stop washer is being touched and checked for movement.

7. Ensure that the float lock linkage is on the down stops (washer [A] cannot move) at both locations.

#### NOTE:

If the header is **NOT** on the down stops, the voltage may go out of range during operation and cause the AHHC system to malfunction. To fix the problem, make the header heavier by decreasing the float. For instructions, refer to [Checking and Adjusting Header Float, page 210](#).

8. Unlock the header float. For instructions, refer to [Locking / Unlocking Header Float, page 221](#).
9. Lock the header wings. For instructions, refer to [Operating in Rigid Mode, page 224](#).

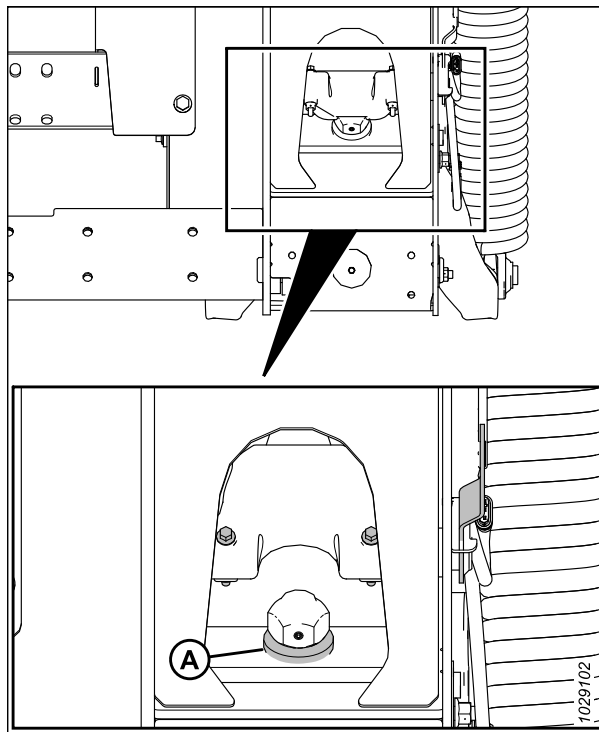


Figure 3.534: Down Stop Washer

10. Press < key (A) or > key (B) to select AUTO HEADER, then press OK key (C). The E5 page indicates whether automatic header height is on or off.

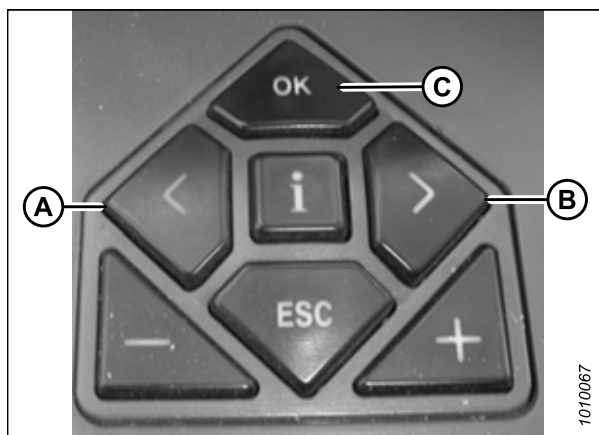


Figure 3.535: CLAAS Lexion Combine Controls

## AUTO HEADER HEIGHT CONTROL SYSTEM

11. Press – key (A) or + key (B) to turn the AHHC on, then press OK key (C).
12. Engage the threshing mechanism and the header.

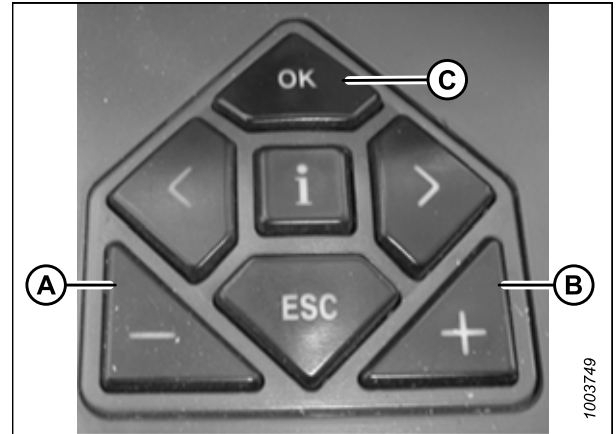


Figure 3.536: CLAAS Lexion Combine Controls

13. Press the < or > key to select CUTT. HEIGHT LIMITS, then press the combine control's OK key.
14. Follow the procedure displayed on the screen to program the upper and lower limits of the header into the CEBIS.

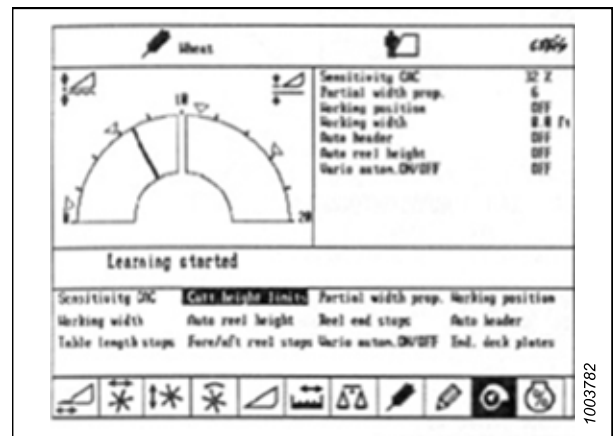


Figure 3.537: CLAAS Lexion Combine Display

15. Press the < or > key to select SENSITIVITY CAC, then press the combine control's OK key.

**NOTE:**

Setting the sensitivity of the AHHC system affects the reaction speed of the AHHC on the header.

16. Press the – key or the + key to change the reaction speed setting, then press the combine control's OK key.

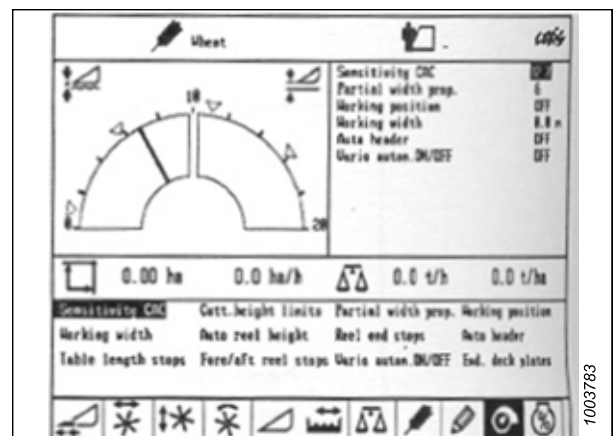


Figure 3.538: CLAAS Lexion Combine Display



## AUTO HEADER HEIGHT CONTROL SYSTEM

17. Check the sensitivity setting by using line (A) or value (B).

**NOTE:**

The setting can be adjusted from 0–100%. When the sensitivity is 0%, the signals from the sensing bands have no effect on the automatic cutting height adjustment. When the sensitivity is 100%, the signals from the sensing bands have the maximum effect on the automatic cutting height adjustment. Adjust the sensitivity from 50%.

18. If the float was adjusted for the calibration procedure, check and adjust the float. For instructions, refer to [Checking and Adjusting Header Float, page 210](#).

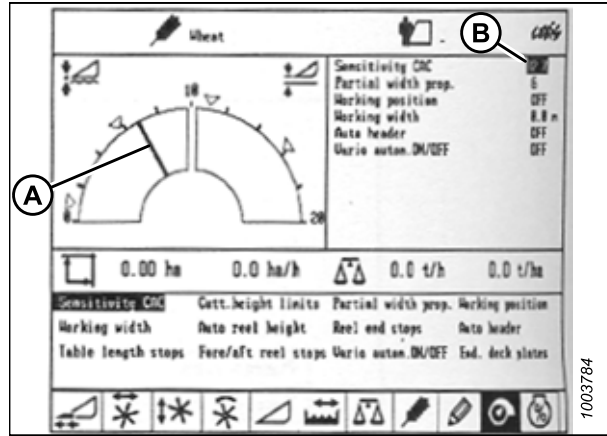


Figure 3.539: CLAAS Lexion Combine Display

### 3.8.2 Cutting Height – CLAAS/CAT Lexion 500 Series and Model 600 Combines

Cutting heights can be programmed into the preset cutting height and auto contour systems. Use the preset cutting height system for cutting heights above 150 mm (6 in.), and use the auto contour system for cutting heights below 150 mm (6 in.).

#### Setting Preset Cutting Height – CLAAS/CAT Lexion 500 Series and Model 600 Combines

Once the auto header height control (AHHC) system has been configured and activated, the preset cutting height can be configured.

**NOTE:**

Changes may have been made to the combine controls or the display since this document was published. For the most up-to-date information, refer to the combine operator’s manual.

**! DANGER**

Ensure that all bystanders have cleared the area.

1. Activate the machine enable switch.
2. Engage the threshing mechanism.
3. Engage the header.
4. Briefly press button (A) in order to activate the auto contour system, or briefly press button (B) in order to activate the preset cutting height system.

**NOTE:**

Button (A) is used only with AHHC function. Button (B) is used only with the return to cut function.



Figure 3.540: Control Handle Buttons



## AUTO HEADER HEIGHT CONTROL SYSTEM

5. Press < key (C) or > key (D) to select the CUTTING HEIGHT page, then press OK key (E).
6. Press – key (A) or + key (B) to set the desired cutting height. An arrow indicates the selected cutting height on the scale.

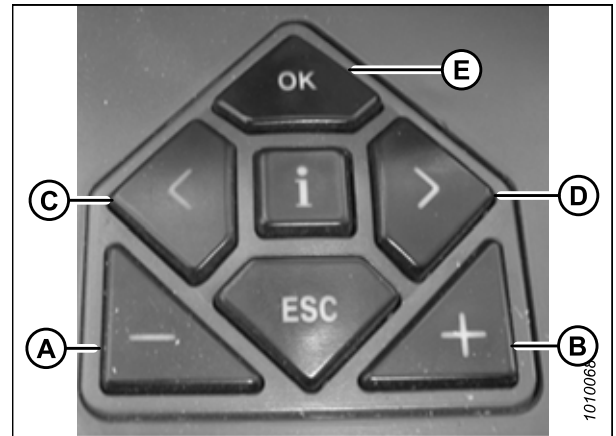


Figure 3.541: CLAAS Lexion Combine Controls

7. Briefly press button (A) or button (B) in order to select the set point.
8. Repeat Step 6, page 349 for the set point.



Figure 3.542: Control Handle Buttons

### *Setting Cutting Height Manually – CLAAS/CAT Lexion 500 Series and Model 600 Combines*

Once the auto header height control (AHHC) system has been configured and activated, the preset cutting height can be configured.

#### **DANGER**

Ensure that all bystanders have cleared the area.

#### **NOTE:**

Changes may have been made to the combine controls or the display since this document was published. For the most up-to-date information, refer to the combine operator's manual.

## AUTO HEADER HEIGHT CONTROL SYSTEM

1. Press button (A) to raise the header, or button (B) to lower the header to the desired cutting height.
2. Press and hold button (C) for 3 seconds to program the cutting height (an alarm will sound after the new setting has been stored).
3. Program a second set point, if desired, by using button (A) to raise the header, or button (B) to lower the header to the desired cutting height, and briefly press button (C) to program the second set point (an alarm will sound after the new setting has been stored).

### NOTE:

For above-the-ground cutting, repeat Step 1, page 350, then use **button (D)** instead of button (C) while repeating Step 2, page 350.



Figure 3.543: Control Handle Buttons

### 3.8.3 Setting Auto Header Height Control Sensitivity – CLAAS/CAT Lexion 500 Series and Model 600 Combines

The sensitivity adjustment controls the distance the cutterbar must travel before the auto header height control (AHHC) moves the feeder house. When the sensitivity is set to maximum, only small changes in the ground height cause the system to move the feeder house. When the sensitivity is set to minimum, only large changes in the ground height cause the system to move the feeder house.

### NOTE:

Set the upper and lower limits of the header before adjusting the sensitivity of the AHHC system. The setting can be adjusted from 0–100%. When the sensitivity is 0%, the signals from the sensing bands have no effect on adjusting the automatic cutting height. When the sensitivity is adjusted to 100%, the signals from the sensing bands have a maximum effect on adjusting the automatic cutting height. Start adjusting the sensitivity from 50%.

### NOTE:

Changes may have been made to the combine controls or the display since this document was published. For the most up-to-date information, refer to the combine operator's manual.

1. Press < key (C) or > key (D) to select SENSITIVITY CAC, then press OK key (E).
2. Press – key (A) or + (B) key to change the reaction speed setting, then press OK key (E).

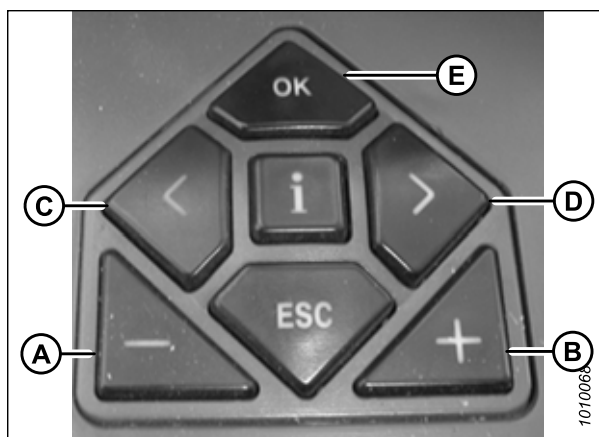


Figure 3.544: CLAAS Lexion Combine Controls

## AUTO HEADER HEIGHT CONTROL SYSTEM

3. Check the sensitivity setting by using line (A) or value (B).

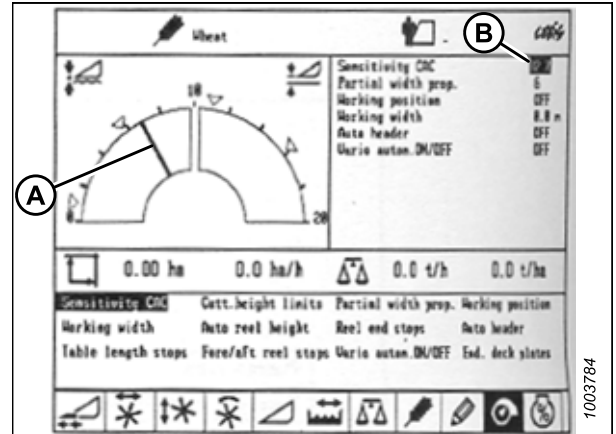
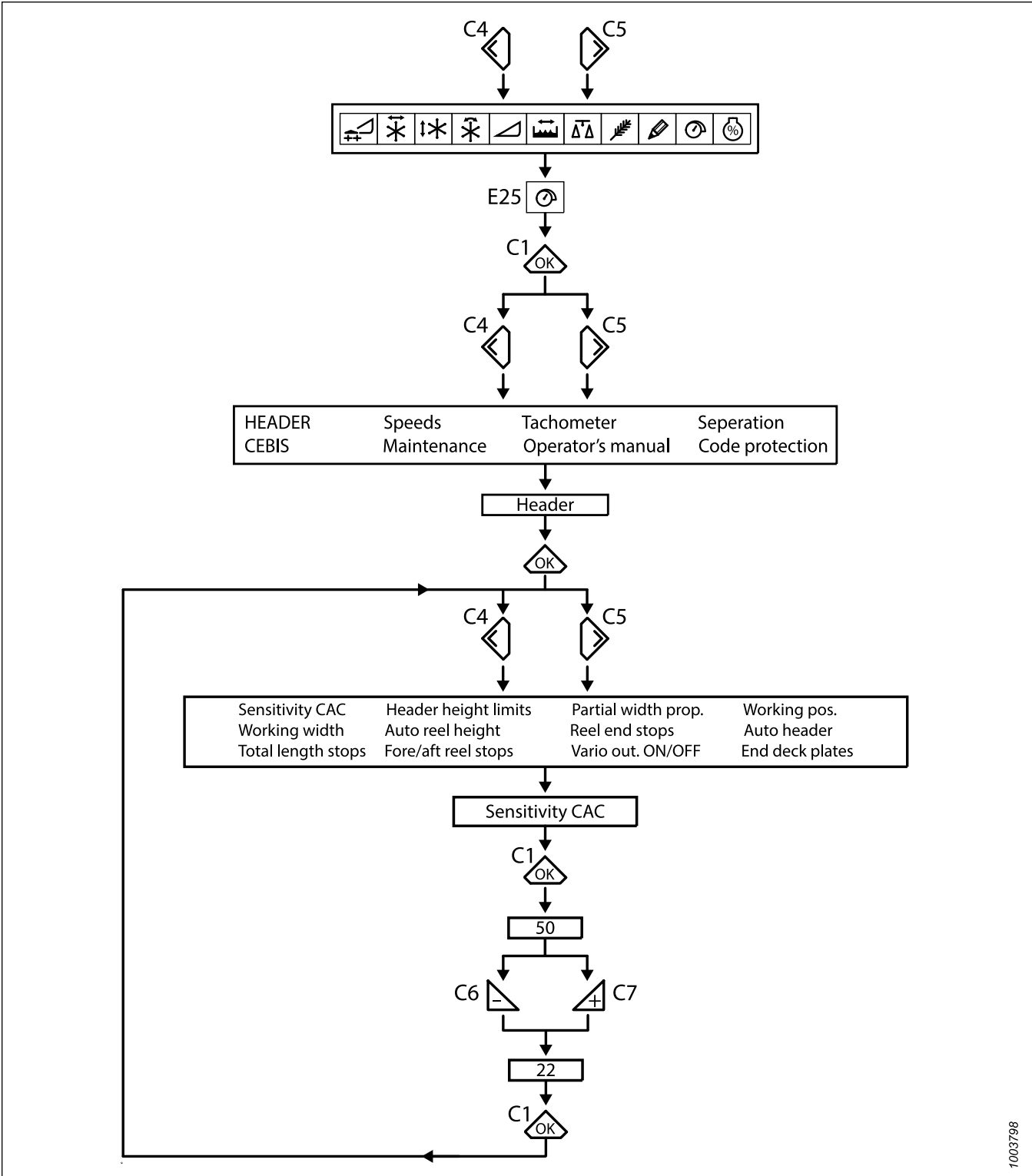


Figure 3.545: CLAAS Lexion Combine Display

AUTO HEADER HEIGHT CONTROL SYSTEM



1003798

Figure 3.546: Flow Chart for Setting the Sensitivity of the Float Optimizer

### 3.8.4 Adjusting Auto Reel Speed – CLAAS/CAT Lexion 500 Series and Model 600 Combines

The preset reel speed can be set when the automatic header functions are activated.

**NOTE:**

Changes may have been made to the combine controls or the display since this document was published. For the most up-to-date information, refer to the combine operator’s manual.

1. Press the < or > key to select REEL WINDOW. Window E15 displays the current advance or retard speed of the reel in relation to the ground speed.

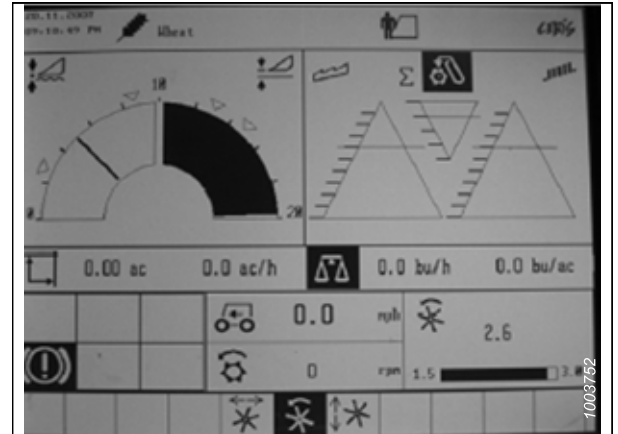


Figure 3.547: CLAAS Lexion Combine Display

2. Press OK key (C) to open the REEL SPEED window.
3. Press – key (A) or + key (B) to set the reel speed in relation to the current ground speed. Window E15 displays the selected reel speed.

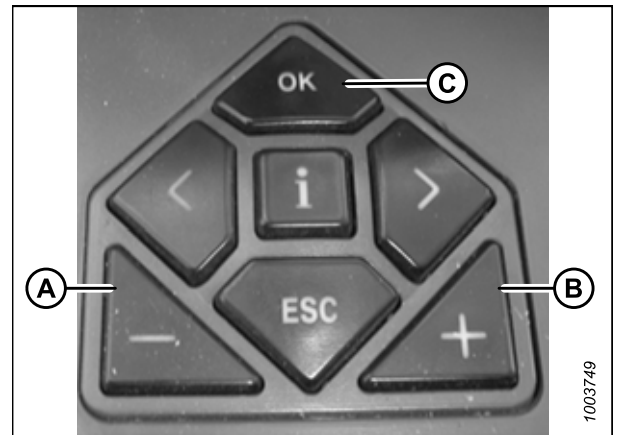


Figure 3.548: CLAAS Lexion Combine Controls

## AUTO HEADER HEIGHT CONTROL SYSTEM

- Adjust the reel speed by rotating the rotary switch to reel position (A).
- Press the – or + key to set the reel speed.



Figure 3.549: CLAAS Lexion Combine Rotary Switch

- Press and hold button (A) or button (B) for 3 seconds to store the setting (an alarm sounds when the new setting has been stored).

**NOTE:**

Whenever button (A) or button (B) is pressed for 3 seconds, the current positions for reel speed and cutting height are stored.



Figure 3.550: CLAAS Lexion Control Handle Buttons

## AUTO HEADER HEIGHT CONTROL SYSTEM

7. Press the < or > key to select REEL WINDOW. Window E15 displays the current advance or retard speed of the reel in relation to the ground speed.

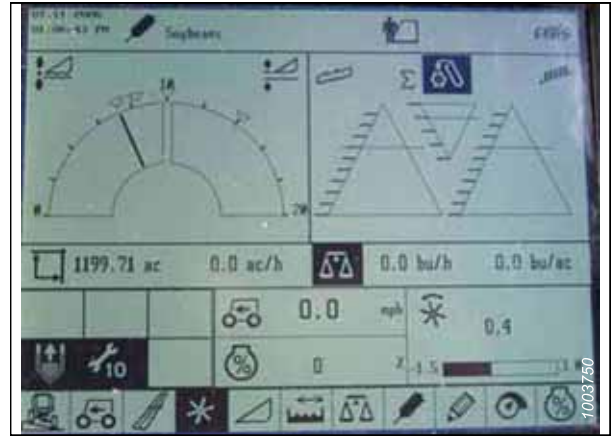


Figure 3.551: CLAAS Lexion Combine Display

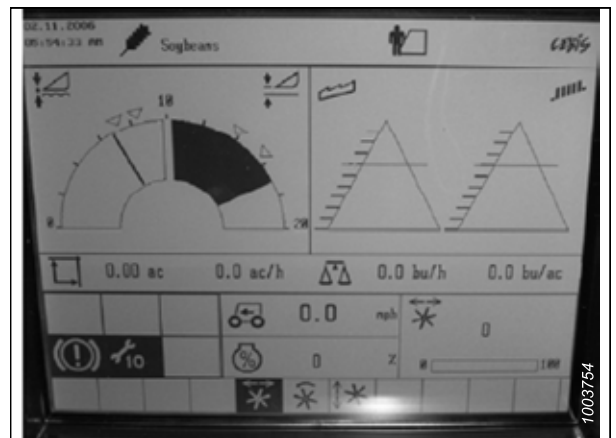


Figure 3.552: CLAAS Lexion Combine Display

8. Press OK key (E), then use < key (C) or > key (D) to select the REEL FORE AND AFT window.
9. Use – key (A) or + key (B) to set the reel fore-aft position.

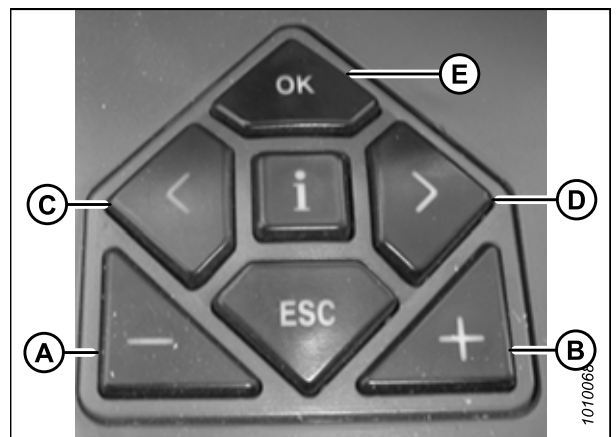


Figure 3.553: CLAAS Lexion Combine Controls

## AUTO HEADER HEIGHT CONTROL SYSTEM

10. Press and hold button (A) or button (B) for 3 seconds to store the setting into the CEBIS (an alarm sounds when the new setting has been stored).

**NOTE:**

Whenever button (A) or button (B) is pressed for 3 seconds, the current positions for reel speed and cutting height are stored.



Figure 3.554: CLAAS Lexion Control Handle Buttons



## 3.9 CLAAS Lexion 600 and 700 Series Combines

To make your header's auto header height control (AHHC) system compatible with the combine, you must set your combine's header configuration options for the particular model of header, configure the reel speed settings, set up the AHHC controls, and calibrate the AHHC system to ensure that it is working correctly.

### 3.9.1 Calibrating Auto Header Height Control – CLAAS Lexion 600 and 700 Series

The auto header height control (AHHC) sensor output must be calibrated for each combine, or the AHHC feature will not work properly.

#### DANGER

To prevent bodily injury or death from the unexpected start-up of the machine, always stop the engine and remove the key from the ignition before making adjustments to the machine.

#### DANGER

Ensure that all bystanders have cleared the area.

#### NOTE:

Changes may have been made to the combine controls or the display since this document was published. For the most up-to-date information, refer to the combine operator's manual.

#### NOTE:

If the header float is set too light, it can prevent the calibration of the AHHC. In order to prevent the header from separating from the float module, it may be necessary to change the float to a heavier setting during calibration.

1. Park the combine on a level surface.
2. Ensure that the header is level with the ground. If adjustment is required:
  - Ensure that the combine is parked on a level surface.
  - If equipped, use the combine's lateral tilt to level the feeder house with the ground.
  - If further adjustment is required, shut the engine off, remove the key from the ignition, and ensure that the combine's tires are inflated to the correct pressure.

#### NOTE:

Spirit level (A) is located on top of the float module frame. The header is level if the bubble is in the center of the spirit level.

3. Ensure that the center-link is set to **D**.

#### NOTE:

When calibration is complete, adjust the center-link back to the desired header angle. For instructions, refer to [3.9.5 Header Angle, page 232](#).

4. Adjust the reel fore-aft position so that the indicator is at position **6**.
5. Position the header so that the cutterbar is 254–356 mm (10–14 in.) off the ground.

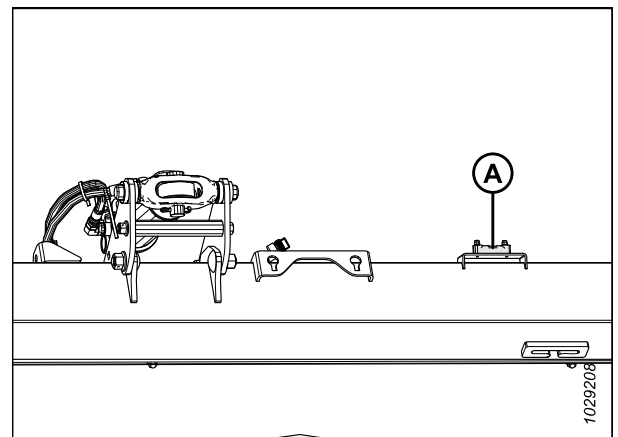


Figure 3.555: Spirit Level

## AUTO HEADER HEIGHT CONTROL SYSTEM

6. Shut down the engine, and remove the key from the ignition.

### CAUTION

To prevent cuts, pinches, and other bodily harm to the person checking the down stops, ensure that nobody is manually lifting, bouncing, or moving the header in any way while the down stop washer is being touched and checked for movement.

7. Ensure that the float lock linkage is on the down stops (washer [A] cannot move) at both locations.

#### NOTE:

If the header is **NOT** on the down stops, the voltage may go out of range during operation and cause the AHHC system to malfunction. To fix the problem, make the header heavier by decreasing the float. For instructions, refer to [Checking and Adjusting Header Float, page 210](#).

8. Unlock the header float. For instructions, refer to [Locking / Unlocking Header Float, page 221](#).
9. Lock the header wings. For instructions, refer to [Operating in Rigid Mode, page 224](#).

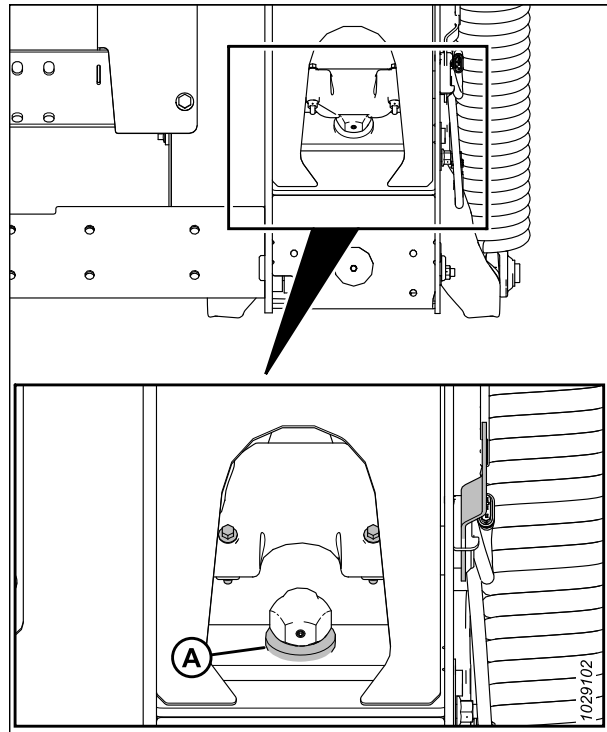


Figure 3.556: Down Stop Washer

10. Use control knob (A) to highlight AUTO CONTOUR icon (B). Press control knob (A) to select it.

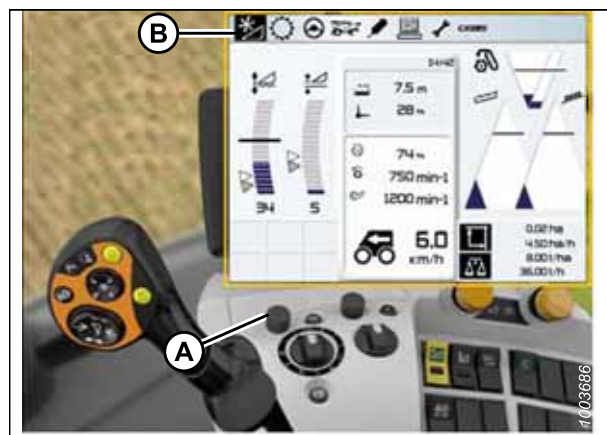


Figure 3.557: CLAAS Lexion Combine Display, Console, and Control Handle

## AUTO HEADER HEIGHT CONTROL SYSTEM

11. Use control knob (A) to highlight the icon resembling a header with up and down arrows (not shown). Press control knob (A) to select it. Highlighted header icon (B) will appear on the screen.



Figure 3.558: CLAAS Lexion Combine Display, Console, and Control Handle

12. Use control knob (A) to highlight header icon (B). Press control knob (A) to select it.

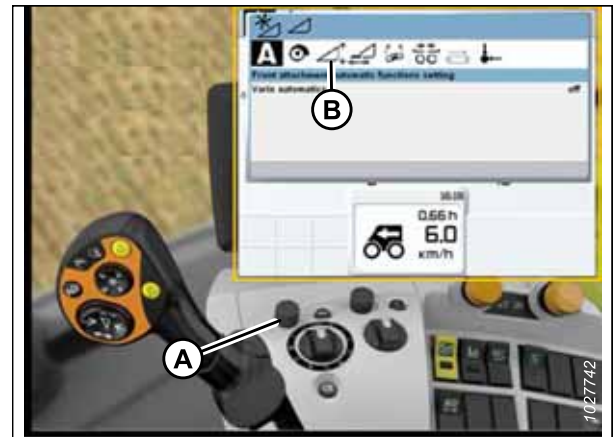


Figure 3.559: CLAAS Lexion Combine Display, Console, and Control Handle

13. Use control knob (A) to highlight screwdriver icon (B).
14. Engage the combine separator and feeder house.
15. Press control knob (A). A progress bar appears.



Figure 3.560: CLAAS Lexion Combine Display, Console, and Control Handle

## AUTO HEADER HEIGHT CONTROL SYSTEM

16. Fully raise the feeder house. Progress bar (A) advances to 25%.
17. Fully lower the feeder house. Progress bar (A) advances to 50%.
18. Fully raise the feeder house. Progress bar (A) advances to 75%.
19. Fully lower the feeder house. Progress bar (A) advances to 100%.



Figure 3.561: CLAAS Lexion Combine Display, Console, and Control Handle

20. Ensure that progress bar (A) is at 100%. The calibration procedure is now complete.

### NOTE:

If the voltage is not within the range of 0.7–4.3 V at any time throughout the calibration process, the monitor will indicate that the learning procedure has not concluded.

21. If the float was adjusted for the calibration procedure, check and adjust the float. For instructions, refer to [Checking and Adjusting Header Float, page 210](#).



Figure 3.562: CLAAS Lexion Combine Display, Console, and Control Handle

### 3.9.2 Setting Cutting Height – CLAAS Lexion 600 and 700 Series

The Operator can configure two different cutting height presets. The height presets can be selected using the combine's control handle.

#### DANGER

Ensure that all bystanders have cleared the area.

### NOTE:

Changes may have been made to the combine controls or the display since this document was published. For the most up-to-date information, refer to the combine operator's manual.

## AUTO HEADER HEIGHT CONTROL SYSTEM

1. Lower the header to the desired cutting height or to the ground pressure setting. The float indicator box should be set to 1.5.
2. Hold the left side of switch (A) until you hear a ping sound.



Figure 3.563: CLAAS Lexion Combine Display, Console, and Control Handle

### 3.9.3 Setting Auto Header Height Control Sensitivity – CLAAS Lexion 600 and 700 Series

The sensitivity adjustment controls the time that the cutterbar must travel before the auto header height control (AHHC) moves the feeder house. When the sensitivity is set to maximum, only small changes in the ground height cause the feeder house to move. When the sensitivity is set to minimum, only large changes in the ground height cause the feeder house to move.

#### NOTE:

Changes may have been made to the combine controls or the display since this document was published. For the most up-to-date information, refer to the combine operator's manual.

1. Use control knob (A) to highlight HEADER/REEL icon (B). Press control knob (A) to select it. The HEADER/REEL dialog box opens.
2. Select the HEADER icon.

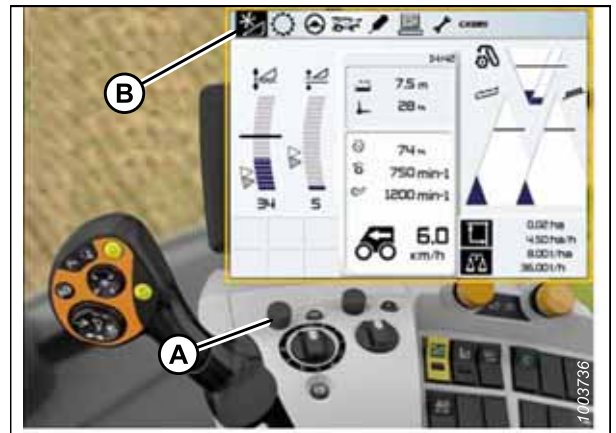


Figure 3.564: CLAAS Lexion Combine Display, Console, and Control Handle



## AUTO HEADER HEIGHT CONTROL SYSTEM

3. Select FRONT ATTACHMENT PARAMETER SETTINGS icon (A). A list of settings appears.
4. Select SENSITIVITY CAC (B) from the list.



Figure 3.565: CLAAS Lexion Combine Display, Console, and Control Handle

5. Select SENSITIVITY CAC icon (A).
6. If the reaction time between the header and the float module is too slow while cutting on the ground, increase CUTTING HEIGHT ADJUSTMENT setting (B). If the reaction time between the header and the float module is too fast, decrease the CUTTING HEIGHT ADJUSTMENT setting.

### NOTE:

The settings from 1–50 provide a faster response, whereas the settings from -1 to -50 provide a slower response. For the best results, make adjustments in increments of 5.

7. If the header lowers too slowly, increase the sensitivity. If the header hits the ground too hard or lowers too quickly, decrease the sensitivity.



Figure 3.566: CLAAS Lexion Combine Display

### 3.9.4 Adjusting Auto Reel Speed – CLAAS Lexion 600 and 700 Series

You can set the preset reel speed after activating the automatic header functions.

### NOTE:

Changes may have been made to the combine controls or the display since this document was published. For the most up-to-date information, refer to the combine operator's manual.

## AUTO HEADER HEIGHT CONTROL SYSTEM

1. Use control knob (A) to highlight HEADER/REEL icon (B). Press control knob (A) to select it. The HEADER/REEL dialog box appears.

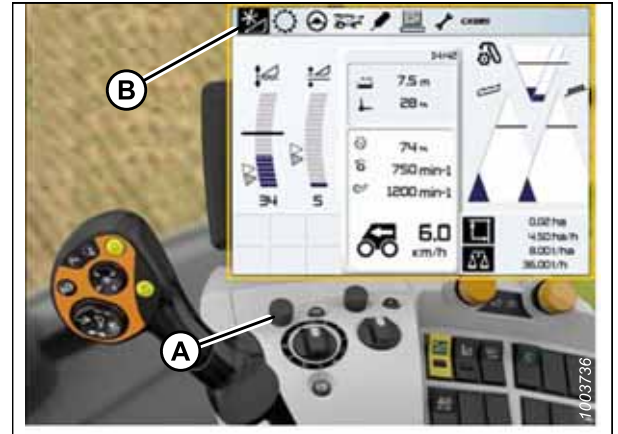


Figure 3.567: CLAAS Lexion Combine Display, Console, and Control Handle

2. Use control knob (A) to select REEL SPEED (B), and adjust the reel speed (if you are **NOT** using Auto Reel Speed). A graph appears in the dialog box.



Figure 3.568: CLAAS Lexion Combine Display, Console, and Control Handle

3. Select ACTUAL VALUE (A) from the AUTO REEL SPEED dialog box (if you are using Auto Reel Speed). The ACTUAL VALUE dialog box indicates the auto reel speed.



Figure 3.569: CLAAS Lexion Combine Display, Console, and Control Handle

## AUTO HEADER HEIGHT CONTROL SYSTEM

4. Use control knob (A) to adjust the reel speed.

**NOTE:**

This option is only available with the engine at full throttle.



Figure 3.570: CLAAS Lexion Combine Display, Console, and Control Handle

### 3.9.5 Calibrating Reel Height Sensor and Reel Fore-Aft Sensor – CLAAS Lexion 600 and 700 Series

The auto header height control (AHHC) sensor output must be calibrated for each combine, or the AHHC feature will not work properly.

**NOTE:**

Changes may have been made to the combine controls or the display since this document was published. For the most up-to-date information, refer to the combine operator's manual.

**NOTE:**

If the header float is set too light, it can prevent the calibration of the AHHC. You may need to set the float heavier for the calibration procedure so the header does not separate from the float module.



## AUTO HEADER HEIGHT CONTROL SYSTEM

### NOTE:

Calibrating the reel fore-aft sensor is only possible if the header is integration-equipped. If the float module is equipped with connector (A) next to multicoupler (B), the header is **NOT** integration-equipped.

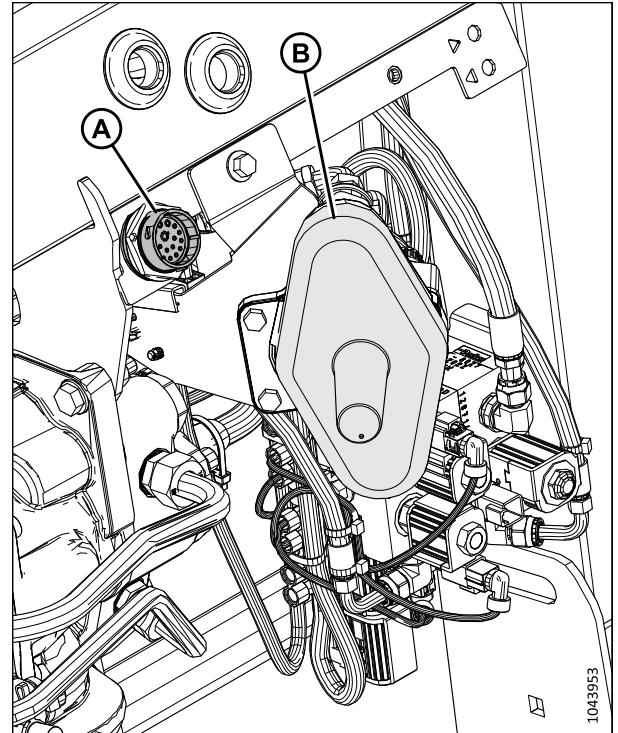


Figure 3.571: Integration Module Installed on Multicoupler

### DANGER

Ensure that all bystanders have cleared the area.

1. Ensure that the center-link is set to **D**.

### NOTE:

When calibration is complete, adjust the center-link back to the desired header angle. For instructions, refer to [3.9.5 Header Angle, page 232](#).

2. Start the engine.
3. Position the header 254–356 mm (10–14 in.) off the ground. Keep the engine running.

### IMPORTANT:

Do **NOT** turn off the engine. The combine has to be at full throttle for the sensors to calibrate properly.

## AUTO HEADER HEIGHT CONTROL SYSTEM

- Use control knob (A) to highlight FRONT ATTACHMENT icon (B). Press control knob (A) to select it.



Figure 3.572: CLAAS Lexion Combine Display, Console, and Control Handle

- Use control knob (A) to highlight REEL icon (B). Press control knob (A) to select it.

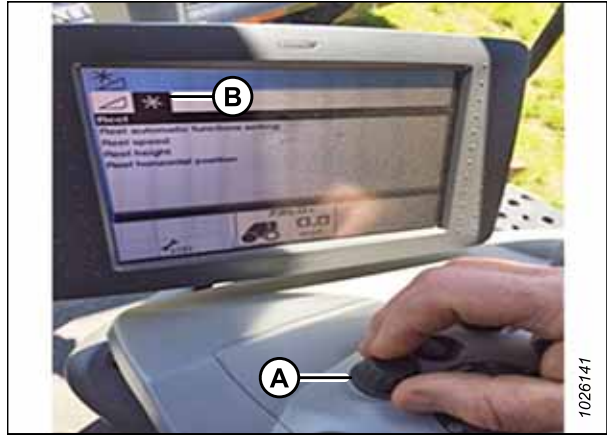


Figure 3.573: CLAAS Lexion Combine Display and Console

- Highlight REEL HEIGHT icon (A). Press the control knob to select it.
- Select LEARNING END STOPS (B) from the list.



Figure 3.574: CLAAS Lexion Combine Display and Console

## AUTO HEADER HEIGHT CONTROL SYSTEM

- Use control knob (A) to highlight screwdriver icon (B).
- Press the control knob.



Figure 3.575: CLAAS Lexion Combine Display, Console, and Control Handle

- Progress bar chart (A) appears on the screen.
- Follow the prompts on the screen to raise and lower the reel.



Figure 3.576: CLAAS Lexion Combine Display, Console, and Control Handle

- Ensure that progress bar chart (A) displays 100%. When the progress bar chart displays 100%, the calibration procedure is complete.



Figure 3.577: CLAAS Lexion Combine Display, Console, and Control Handle

## AUTO HEADER HEIGHT CONTROL SYSTEM

13. **If header is integration-equipped:** Calibrate the reel fore-aft sensor by selecting REEL HORIZONTAL POSITION (A), then LEARNING END STOPS (B).
14. Repeat Step 8, page 367 to Step 12, page 367.



Figure 3.578: CLAAS Lexion Combine Display and Console

### 3.9.6 Adjusting Auto Reel Height – CLAAS Lexion 600 and 700 Series

The auto reel height setting can be configured by accessing the REEL menu on the combine display.

**NOTE:**

Changes may have been made to the combine controls or the display since this document was published. For the most up-to-date information, refer to the combine operator's manual.

1. Use HOTKEY rotary dial (A) to select REEL icon (B).

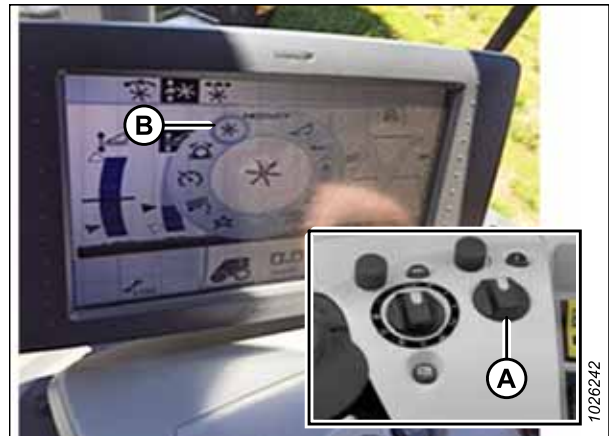


Figure 3.579: CLAAS Lexion Combine Display and Console

## AUTO HEADER HEIGHT CONTROL SYSTEM

2. Use control knob (A) to select AUTO REEL HEIGHT icon (B) at the top of the page.

**NOTE:**

AUTO REEL HEIGHT icon (C) at the center of the page should be highlighted black. If it is not black, either the end stops have not been set or the auto header height control (AHHC) is not active. For instructions, refer to [3.9.5 Calibrating Reel Height Sensor and Reel Fore-Aft Sensor – CLAAS Lexion 600 and 700 Series](#), page 364.

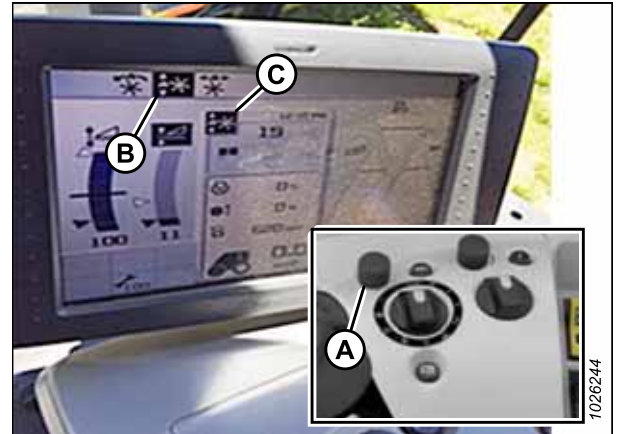


Figure 3.580: CLAAS Lexion Combine Display and Console

3. Adjust the auto reel height position for the current AHHC position using outer scroll knob (A). To lower the preset reel position, turn the scroll knob counterclockwise; to raise the preset reel position, turn the scroll knob clockwise. The display will update current setting (B).

**NOTE:**

If the AUTO REEL HEIGHT icon in the center of the page is not black, an AHHC position is not currently active.

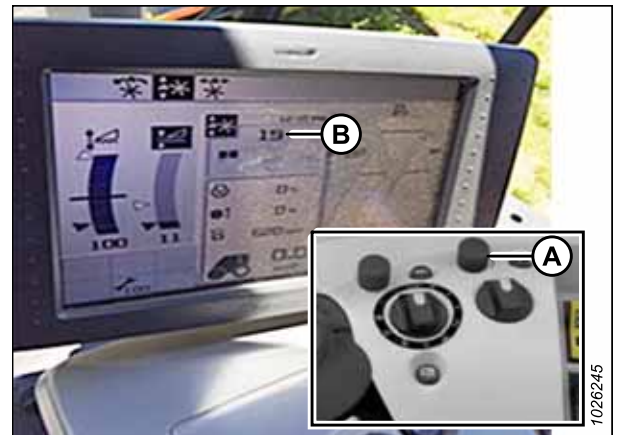


Figure 3.581: CLAAS Lexion Combine Display and Console



### 3.10 CLAAS Lexion 6000, 7000 and 8000 Series, and CLAAS Trion 600 and 700 Series Combines

To make your header’s auto header height control (AHHC) system compatible with the combine, you must set your combine’s header configuration options for the particular model of header, configure the reel speed settings, set up the AHHC controls, and calibrate the AHHC system to ensure that it is working correctly.

#### 3.10.1 Header Settings Quick Reference – CLAAS Lexion 6000, 7000 and 8000 Series, and CLAAS Trion 600 and 700 Series Combines

The recommended auto header height control (AHHC) settings for an FD2 Series FlexDraper® header operating with a CLAAS Lexion 6000, 7000 or 8000 Series, or CLAAS Trion 600 or 700 series combine provided.

**Table 3.42 Header Settings – CLAAS Lexion 6000, 7000 and 8000 Series, and CLAAS Trion 600 and 700 Series Combines**

Setup Parameter	Suggested Setting
Front attachment type	Flex cutterbar product by other manufacturer
Working width	Set header width
Drop rate with auto contour	Adjust to preference
Reel speed adjust	Adjust to preference

#### 3.10.2 Setting up Header – CLAAS Lexion 6000, 7000 and 8000 Series, and CLAAS Trion 600 and 700 Series Combines

To set up a header to work with the auto header height control (AHHC) system, you will need to access the FRONT ATTACHMENT menu using the CEBIS terminal.

**NOTE:**

Changes may have been made to the combine controls or the display since this document was published. For the most up-to-date information, refer to the combine operator’s manual.

1. From the main page, select FRONT ATTACHMENT (A).



Figure 3.582: CEBIS Main Page

## AUTO HEADER HEIGHT CONTROL SYSTEM

2. From the drop down list, select FRONT ATTACHMENT PARAMETERS (A).



Figure 3.583: Front Attachment Page

3. From the FRONT ATTACHMENT PARAMETERS page, select FRONT ATTACHMENT TYPE (A).
4. From the drop down list, select FLEX CUTTERBAR PRODUCT BY OTHER MANUFACTURER (B).

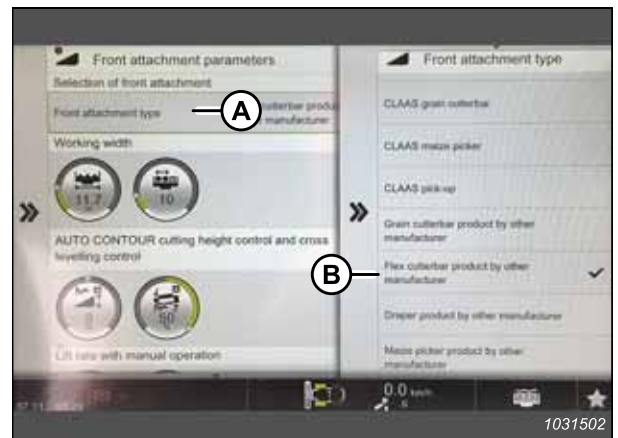


Figure 3.584: Attachment Parameters Page

5. From the FRONT ATTACHMENT PARAMETERS page, select WORKING WIDTH (A).
6. Set the header width by sliding adjuster arrow (B) up or down.
7. Select check mark (C) to save the settings.

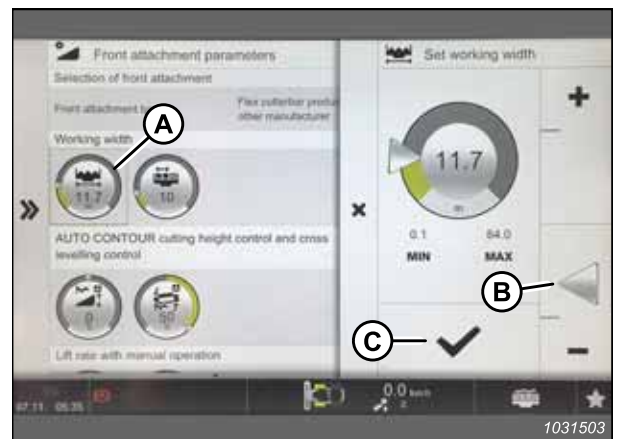


Figure 3.585: Attachment Parameters Page

### 3.10.3 Calibrating Auto Header Height Control – CLAAS Lexion 6000, 7000 and 8000 Series, and CLAAS Trion 600 and 700 Series Combines

The auto header height control (AHHC) sensor output must be calibrated for each combine, or the AHHC feature will not work properly.

**⚠ DANGER**

To prevent bodily injury or death from the unexpected start-up of the machine, always stop the engine and remove the key from the ignition before making adjustments to the machine.

**⚠ DANGER**

Ensure that all bystanders have cleared the area.

**NOTE:**

Changes may have been made to the combine controls or the display since this document was published. For the most up-to-date information, refer to the combine operator’s manual.

**NOTE:**

If the header float is set too light, it can prevent the calibration of the AHHC. In order to prevent the header from separating from the float module, it may be necessary to change the float to a heavier setting during calibration.

1. Park the combine on a level surface.
2. Lower the header fully.
3. Shut down the engine, and remove the key from the ignition.
4. Ensure that the header is level with the ground. If adjustment is required:
  - Ensure that the combine is parked on a level surface.
  - If equipped, use the combine’s lateral tilt to level the feeder house with the ground.
  - If further adjustment is required, shut the engine off, remove the key from the ignition, and ensure that the combine’s tires are inflated to the correct pressure.

**NOTE:**

Spirit level (A) is located on top of the float module frame. The header is level if the bubble is in the center of the spirit level.

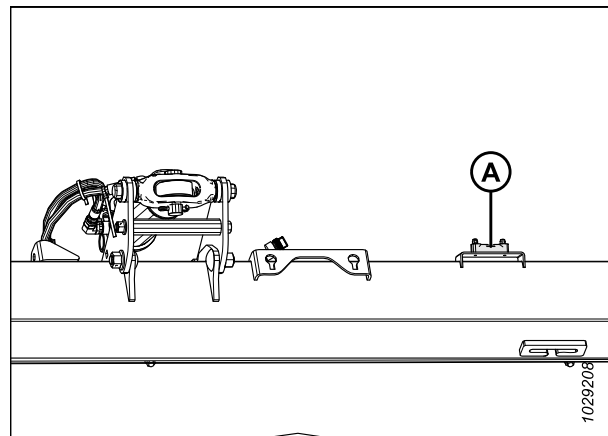


Figure 3.586: Spirit Level

5. Ensure that the center-link is set to **D**.

**NOTE:**

When calibration is complete, adjust the center-link back to the desired header angle. For instructions, refer to [3.9.5 Header Angle, page 232](#).

6. Adjust the reel fore-aft position so that the indicator is at position **6**.
7. Position the header so that the cutterbar is 254–356 mm (10–14 in.) off the ground.





## AUTO HEADER HEIGHT CONTROL SYSTEM

13. Select LEARNING PROCEDURES (A) from the menu.
14. Select FRONT ATTACHMENT HEIGHT (B).

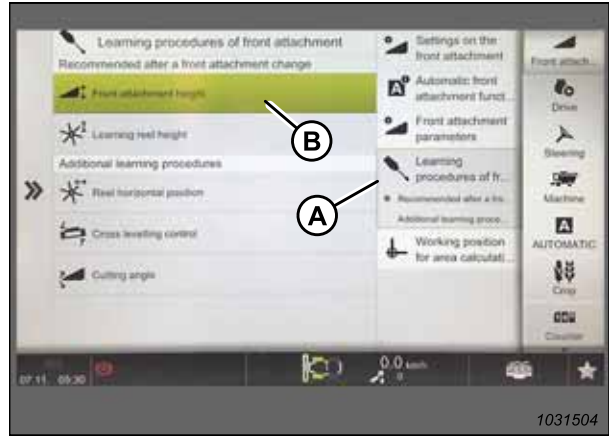


Figure 3.589: Learning Procedures Page

15. Follow the prompts that appear in DESCRIPTION and NOTES fields (A).

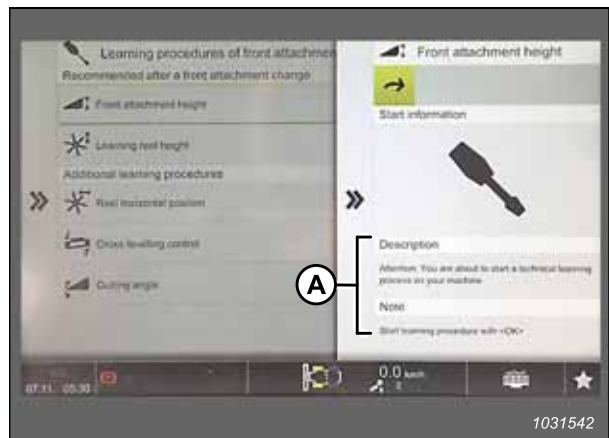


Figure 3.590: Front Attachment Height Page

16. When prompted, press OK button (A) to start the learning procedure.



Figure 3.591: Operator Controls

17. When prompted, raise the front attachment with button (A) on the multifunction lever.
18. When prompted, lower the front attachment with button (B) on the multifunction lever.
19. Repeat Steps 17, page 375 and 18, page 375 until calibration is complete.



Figure 3.592: Multifunction Lever

### 3.10.4 Setting Cut and Reel Height Preset – CLAAS Lexion 6000, 7000 and 8000 Series, and CLAAS Trion 600 and 700 Series Combines

The reel and cut height setting can be stored in the combine. When harvesting, select the setting from the control handle.

#### DANGER

Ensure that all bystanders have cleared the area.

#### NOTE:

Changes may have been made to the combine controls or the display since this document was published. For the most up-to-date information, refer to the combine operator's manual.

## AUTO HEADER HEIGHT CONTROL SYSTEM

1. Set the desired cutting height with feeder house raise/lower buttons (A) on the multifunction lever.
2. Set the desired reel position with buttons (B).
3. Press and hold AUTO HEIGHT PRESET button (C) to store the settings.



Figure 3.593: Multifunction Lever

### NOTE:

Triangle (A) appears on the header height gauge indicating the preset level.



Figure 3.594: CEBS Main Page

### 3.10.5 Setting Auto Header Height Control Sensitivity – CLAAS Lexion 6000, 7000 and 8000 Series, and CLAAS Trion 600 and 700 Series Combines

The sensitivity adjustment controls the time the cutterbar must travel before the auto header height control (AHHC) moves the feeder house. When the sensitivity is set to maximum, only small changes in ground height are needed to cause the system to move the feeder house. When the sensitivity is set to minimum, only large changes in the ground height cause the system to move the feeder house.

### DANGER

Ensure that all bystanders have cleared the area.

### NOTE:

Changes may have been made to the combine controls or the display since this document was published. For the most up-to-date information, refer to the combine operator's manual.

## AUTO HEADER HEIGHT CONTROL SYSTEM

1. From the main page, select FRONT ATTACHMENT (A).



Figure 3.595: CEBIS Main Page

2. From the drop down list, select FRONT ATTACHMENT PARAMETERS (A).



Figure 3.596: Front Attachment Parameters Page

3. Scroll through the list and select DROP RATE WITH AUTO CONTOUR icon (A).
4. Adjust the drop rate by sliding adjuster arrow (B) up or down.
5. Select check mark (C) to confirm the settings.

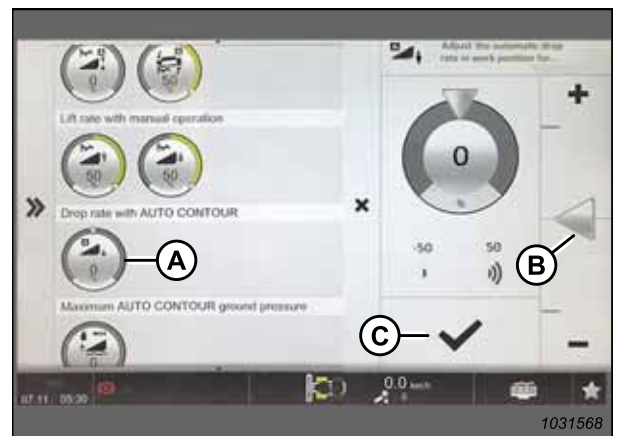


Figure 3.597: Drop Rate with Auto Contour Page

### 3.10.6 Adjusting Auto Reel Speed – CLAAS Lexion 6000, 7000 and 8000 Series, and CLAAS Trion 600 and 700 Series Combines

The preset reel speed can be set after activating the automatic header functions.

#### **!** DANGER

Ensure that all bystanders have cleared the area.

#### NOTE:

Changes may have been made to the combine controls or the display since this document was published. For the most up-to-date information, refer to the combine operator’s manual.

1. From the main page, select FRONT ATTACHMENT (A).



Figure 3.598: CEBIS Main Page

2. From the list, select SETTINGS ON FRONT ATTACHMENT (A).
3. Select REEL TARGET VALUES (B).
4. Select REEL SPEED ADJUST icon (C).



Figure 3.599: Settings on Front Attachment Page

## AUTO HEADER HEIGHT CONTROL SYSTEM

- Adjust the reel speed target value by sliding adjuster arrow (A) up or down.
- Select check mark (B) to save the setting.



Figure 3.600: Reel Speed Target Value Page

### 3.10.7 Calibrating Reel Height Sensor and Reel Fore-Aft Sensor – CLAAS Lexion 6000, 7000 and 8000 Series, and CLAAS Trion 600 and 700 Series Combines

The auto header height control (AHHC) sensor output must be calibrated for each combine, or the reel position feature will not work properly.

#### **DANGER**

Ensure that all bystanders have cleared the area.

#### **NOTE:**

Changes may have been made to the combine controls or the display since this document was published. For the most up-to-date information, refer to the combine operator's manual.



## AUTO HEADER HEIGHT CONTROL SYSTEM

### NOTE:

Calibrating the reel fore-aft sensor is only possible if the header is integration-equipped. If the float module is equipped with connector (A) next to multicoupler (B), the header is **NOT** integration-equipped.

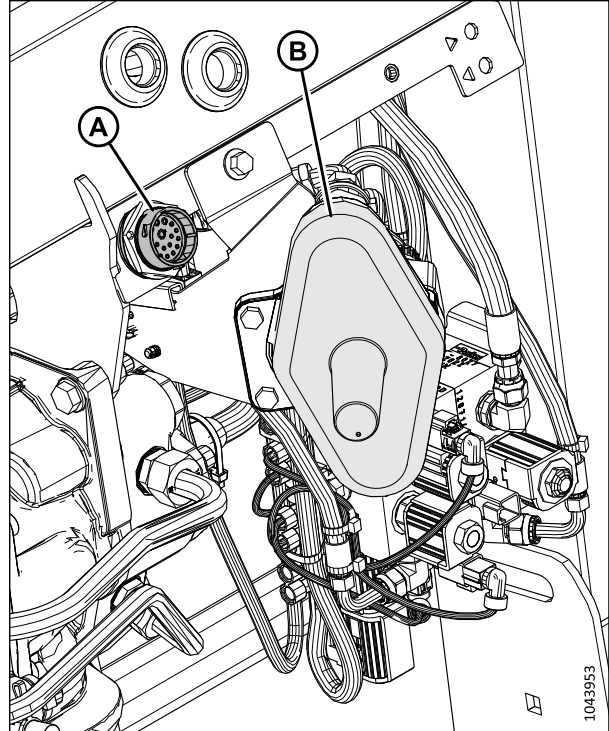


Figure 3.601: Integration Module Installed on Multicoupler

1. Park the combine on a level surface.
2. Position the header so that the cutterbar is 254–356 mm (10–14 in.) off the ground.

### NOTE:

Do **NOT** turn off the engine. The combine has to be at full idle for the sensors to calibrate properly.

3. From the main page, select FRONT ATTACHMENT (A).



Figure 3.602: CEBIS Main Page



## AUTO HEADER HEIGHT CONTROL SYSTEM

4. Select LEARNING PROCEDURES FOR FRONT ATTACHMENT (A).
5. Select LEARNING REEL HEIGHT (B).

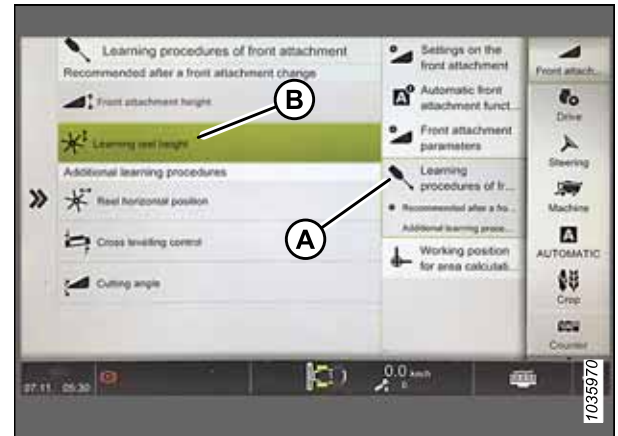


Figure 3.603: Front Attachment Page

6. Follow the prompts that appear in DESCRIPTION and NOTES fields (A).

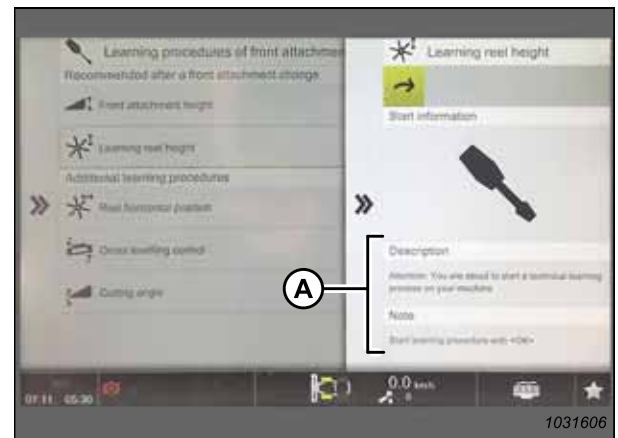


Figure 3.604: Learning Reel Height Page

## AUTO HEADER HEIGHT CONTROL SYSTEM

- When prompted, select OK button (A) to start the learning procedure.



Figure 3.605: Operator Controls

- If the header is integration-equipped:** Calibrate the reel fore-aft sensor by selecting REEL HORIZONTAL POSITION (A) as the learning procedure and follow the prompts on the screen.

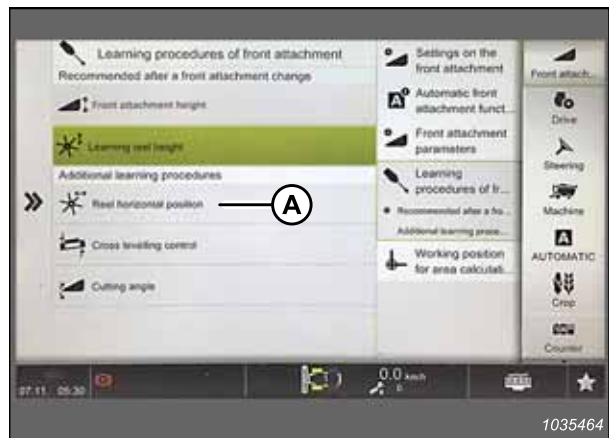


Figure 3.606: Front Attachment Page

### 3.11 Gleaner® R65, R66, R75, R76, and Pre-2016 S Series Combines

To make your header's auto header height control (AHHC) system compatible with the combine, configure the reel speed settings, set up the AHHC controls, and calibrate the AHHC system to ensure that it is working correctly.

#### 3.11.1 Checking Voltage Range from Combine Cab – Gleaner® R65, R66, R75, R76, and Pre-2016 S Series

The auto header height control (AHHC) sensor needs to operate in a specific voltage range in order to work properly.

**NOTE:**

Changes may have been made to the combine controls or the display since this document was published. For the most up-to-date information, refer to the combine operator's manual.

**! DANGER**

To prevent bodily injury or death from the unexpected start-up of the machine, always stop the engine and remove the key from the ignition before making adjustments to the machine.

**! DANGER**

Ensure that all bystanders have cleared the area.

1. Position the header so that the cutterbar is 254–356 mm (10–14 in.) off the ground.
2. Shut down the engine, and remove the key from the ignition.
3. Unlock the header float. For instructions, refer to *Locking / Unlocking Header Float, page 221*.
4. Lock the header wings. For instructions, refer to *Operating in Rigid Mode, page 224*.

**! CAUTION**

To prevent cuts, pinches, and other bodily harm to the person checking the down stops, ensure that nobody is manually lifting, bouncing, or moving the header in any way while the down stop washer is being touched and checked for movement.

5. Ensure that the float lock linkage is on the down stops (washer [A] cannot move) at both locations.

**NOTE:**

If the header is **NOT** on the down stops, the voltage may go out of range during operation and cause the AHHC system to malfunction. To fix the problem, make the header heavier by decreasing the float. For instructions, refer to *Checking and Adjusting Header Float, page 210*.

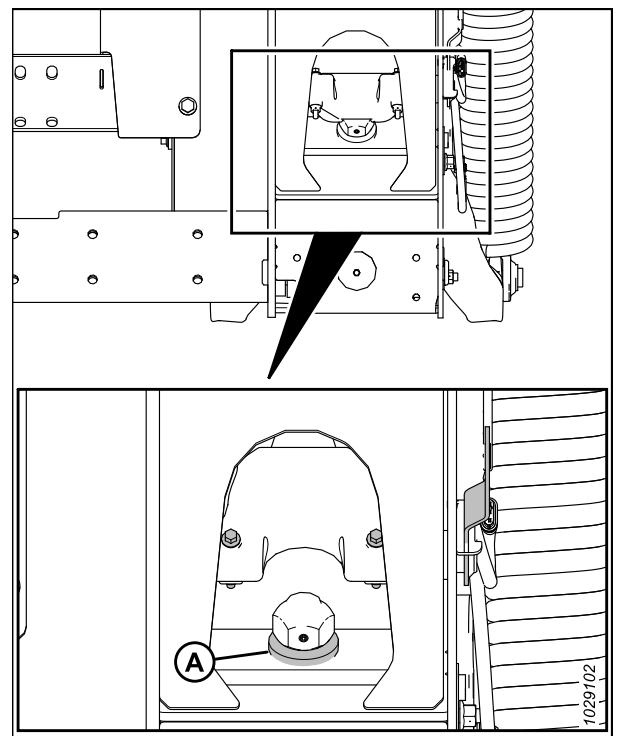


Figure 3.607: Down Stop Washer

## AUTO HEADER HEIGHT CONTROL SYSTEM

- If the pointer is not on zero, loosen bolt (A) and rotate float indicator plate (B) until pointer (C) is on 0 (D). Tighten the nut on bolt (A).

**NOTE:**

Use zero dot (E) above the decal to correctly set the indicator needle.

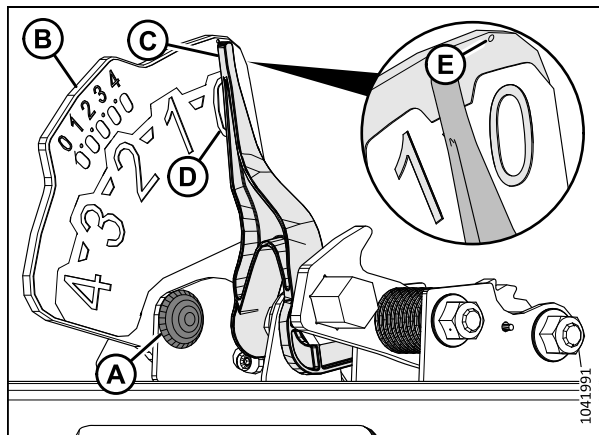


Figure 3.608: Float Indicator

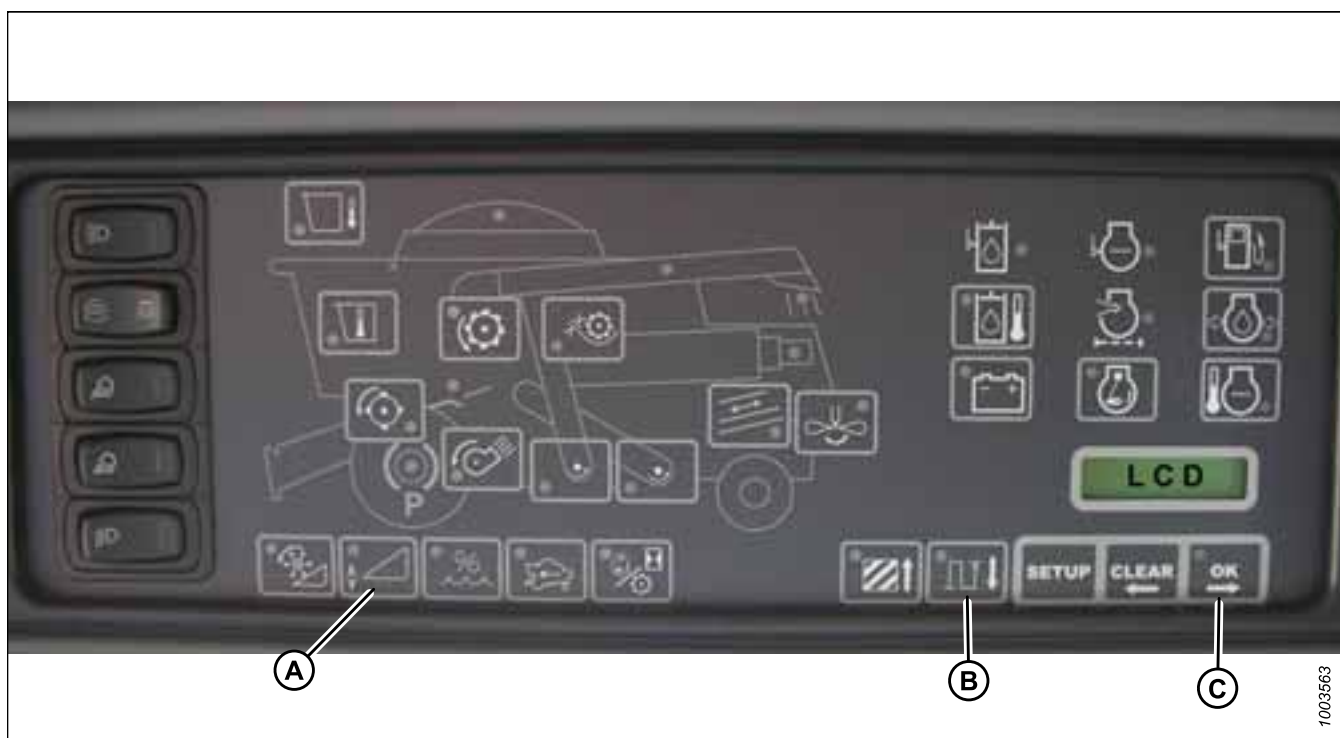


Figure 3.609: Combine Heads-Up Display

- Ensure that the header float is unlocked.
- Press and hold button (A) on the heads-up display for 3 seconds to enter diagnostic mode.
- Scroll down using button (B) until LEFT is displayed on the LCD screen.
- Press OK button (C). The number indicated on the LCD screen is the voltage reading from the sensor of the AHHC. Raise and lower the header to see the full range of the voltage readings.
- If the sensor voltage is not within the lower and upper limits, or if the range between the lower and upper limits is insufficient, refer to [3.3 Manually Checking Voltage Limits, page 296](#).

### 3.11.2 Engaging Auto Header Height Control – Gleaner® R65, R66, R75, R76, and Pre-2016 S Series

The auto header height control (AHHC) must be engaged before you can adjust it for height and sensitivity.

**⚠ DANGER**

Ensure that all bystanders have cleared the area.

**NOTE:**

Changes may have been made to the combine controls or the display since this document was published. For the most up-to-date information, refer to the combine operator’s manual.

The following system components are required in order for the auto header height control (AHHC) to work:

- Main module and header driver module mounted in card box in fuse panel (FP) module.
- Multifunction control handle operator inputs.
- Operator inputs mounted in the control console (CC) module panel.
- Electrohydraulic header lift control valve.



Figure 3.610: Combine Auto Header Height Controls

1. Press AUTO MODE button (A) until AHHC LED light (B) begins flashing. If the RTC light is flashing, press AUTO MODE button (A) again until it switches to the AHHC.

## AUTO HEADER HEIGHT CONTROL SYSTEM

2. Briefly press button (A) on the control handle. The AHHC light should change from flashing to solid. The header should drop to the ground. The AHHC is now engaged and can be adjusted for height and sensitivity.
3. Use the controls to adjust the height and sensitivity to the constant changing ground conditions such as shallow gullies and field drainage trenches.

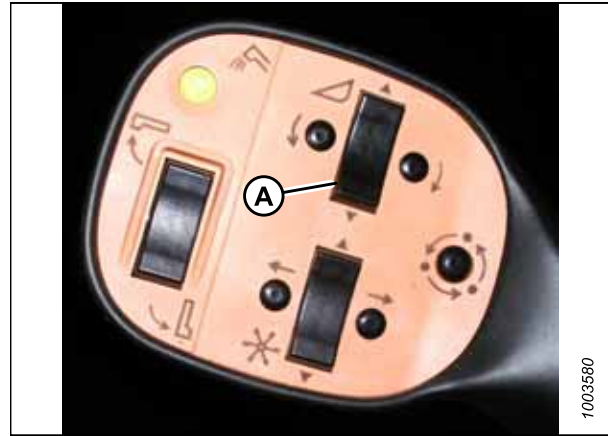


Figure 3.611: Control Handle

### 3.11.3 Calibrating Auto Header Height Control – Gleaner® R65, R66, R75, R76, and Pre-2016 S Series

The auto header height control (AHHC) sensor output must be calibrated for each combine.

#### DANGER

To prevent bodily injury or death from the unexpected start-up of the machine, always stop the engine and remove the key from the ignition before making adjustments to the machine.

#### DANGER

Ensure that all bystanders have cleared the area.

#### NOTE:

Calibration should be done on flat, level ground without the header engaged. The header height and header tilt functions must not be in auto or standby modes. The engine rpm must be above 2000 rpm. The header tilt option on 2004 and earlier model combines does not work with the headers. This system will have to be removed and disabled in order to calibrate the AHHC. For instructions, refer to the combine operator's manual.

#### NOTE:

Changes may have been made to the combine controls or the display since this document was published. For the most up-to-date information, refer to the combine operator's manual.

#### NOTE:

If the header float is set too light, it can prevent the calibration of the AHHC. In order to prevent the header from separating from the float module, it may be necessary to change the float to a heavier setting during calibration.

## AUTO HEADER HEIGHT CONTROL SYSTEM

1. Park the combine on a level surface.
2. Ensure that the header is level with the ground. If adjustment is required:
  - Ensure that the combine is parked on a level surface.
  - If equipped, use the combine's lateral tilt to level the feeder house with the ground.
  - If further adjustment is required, shut the engine off, remove the key from the ignition, and ensure that the combine's tires are inflated to the correct pressure.

**NOTE:**

Spirit level (A) is located on top of the float module frame. The header is level if the bubble is in the center of the spirit level.

3. Ensure that the center-link is set to **D**.

**NOTE:**

When calibration is complete, adjust the center-link back to the desired header angle. For instructions, refer to [3.9.5 Header Angle, page 232](#).

4. Adjust the reel fore-aft position so that the indicator is at position **6**.
5. Position the header so that the cutterbar is 254–356 mm (10–14 in.) off the ground.
6. Shut down the engine, and remove the key from the ignition.

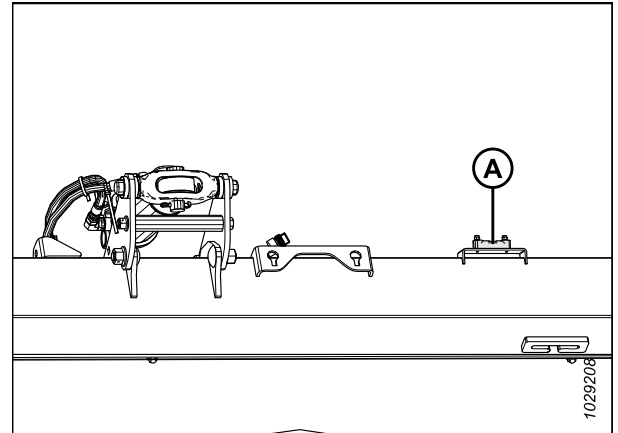


Figure 3.612: Spirit Level

## AUTO HEADER HEIGHT CONTROL SYSTEM

### CAUTION

To prevent cuts, pinches, and other bodily harm to the person checking the down stops, ensure that nobody is manually lifting, bouncing, or moving the header in any way while the down stop washer is being touched and checked for movement.

7. Ensure that the float lock linkage is on the down stops (washer [A] cannot move) at both locations.

#### NOTE:

If the header is **NOT** on the down stops, the voltage may go out of range during operation and cause the AHHC system to malfunction. To fix the problem, make the header heavier by decreasing the float. For instructions, refer to [Checking and Adjusting Header Float, page 210](#).

8. Unlock the header float. For instructions, refer to [Locking / Unlocking Header Float, page 221](#).
9. Lock the header wings. For instructions, refer to [Operating in Rigid Mode, page 224](#).

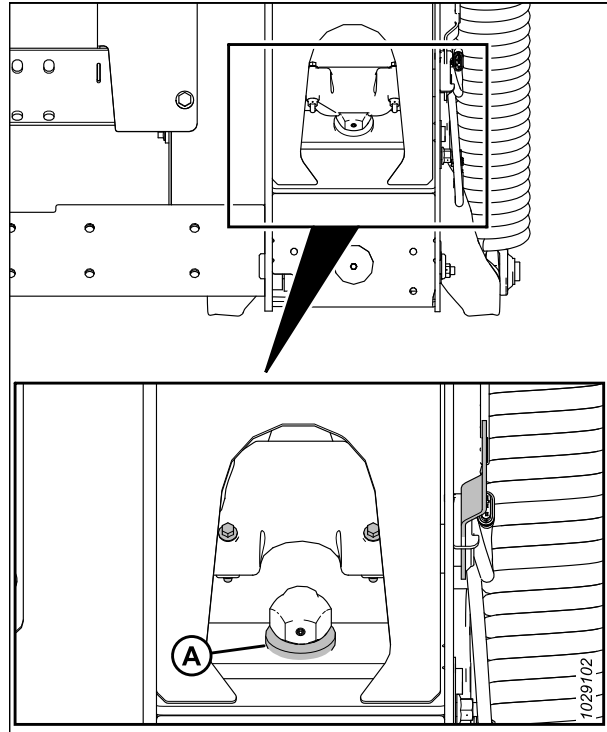


Figure 3.613: Down Stop Washer



## AUTO HEADER HEIGHT CONTROL SYSTEM



Figure 3.614: Combine Auto Header Height Controls

A - AUTO MODE Button  
D - Raise Header Light  
G - CAL2 Button

B - AHHC Light  
E - Lower Header Light

C - CAL1 Button  
F - AUTO Mode

10. Press AUTO MODE button (A) until AHHC light (B) lights up.
  11. Press and hold CAL1 button (C) until you see the following lights flash: raise header (D), lower header (E), tilt AUTO MODE (F), and AHHC (B).
  12. Fully lower the header, and continue to hold the HEADER LOWER button for 5–8 seconds to ensure that the float module has separated from the header.
  13. Press CAL2 button (G) until lower header light (E) stops flashing, and release it when raise header light (D) begins flashing.
  14. Raise the header to its maximum height, and ensure that the header is resting on the down stop pads.
  15. Press CAL2 button (G) until raise header light (D) turns off.
- NOTE:**  
The following steps are applicable only to 2005 and later combines with the Smartrac feeder house.
16. Wait for the HEADER TILT LEFT light (not shown) to start flashing, and then tilt the header to the maximum left position.
  17. Press CAL2 button (G) until the HEADER TILT LEFT light (not shown) stops flashing, and release the button when the HEADER TILT RIGHT light (not shown) begins flashing.
  18. Tilt the header to the maximum right position.
  19. Press CAL2 button (G) until all of the following lights flash: raise header (D), lower header (E), height AUTO MODE (A), right header and left header (not shown), and tilt AUTO MODE (F).

## AUTO HEADER HEIGHT CONTROL SYSTEM

20. Center the header.
21. Press CAL1 button (C) to exit calibration and save all values. All lights should stop flashing.

**NOTE:**

If the float was set heavier to complete the AHHC calibration procedure, adjust it to the recommended operating float after the calibration is complete.

### 3.11.4 Turning off Accumulator – Gleaner® R65, R66, R75, R76, and Pre-2016 S Series

The accumulator affects the combine's height adjustment reaction time, which can affect the auto header height control (AHHC) system's performance.

For best performance, turn the feeder house accumulator off.  
For instructions, refer to the combine operator's manual.

**NOTE:**

The accumulator is located in front of the front left axle beam.



**Figure 3.615: Combine Accumulator ON/OFF Switch**

A - Accumulator Lever (Off Position)

### 3.11.5 Adjusting Header Raise/Lower Rate – Gleaner® R65, R66, R75, R76, and Pre-2016 S Series

The auto header height control (AHHC) system’s stability is affected by hydraulic flow rates. Adjust the header raise/lower rate to ensure the stability of the auto header height control system.

Adjust header raise restrictor (A) and header lower restrictor (B) in the hydraulic manifold so that it takes approximately 6 seconds to raise the header from the ground to maximum height (that is, to the point at which the hydraulic cylinders are fully extended), and approximately 6 seconds to lower the header from maximum height to ground level.

If there is excessive header movement (for example, hunting) when the header is on the ground, adjust the lower rate so that it takes 7 or 8 seconds for the header to drop down to ground level.

**NOTE:**

Make this adjustment with the hydraulic system at its normal operating temperature (54.4°C [130°F]) and the engine running at full throttle.

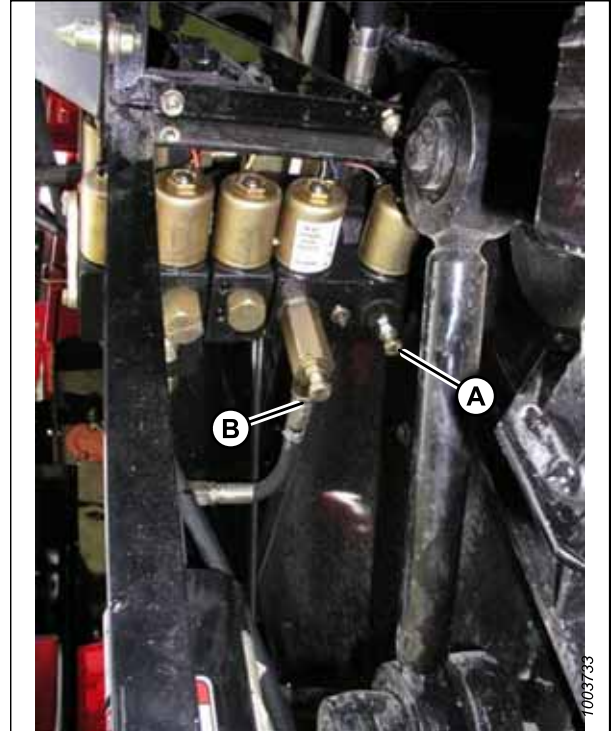


Figure 3.616: Header Raise and Lower Adjustable Restrictors

### 3.11.6 Adjusting Ground Pressure – Gleaner® R65, R66, R75, R76, and Pre-2016 S Series

Adjust the header ground pressure setting so that the pressure is as light as possible, but sufficiently heavy that the header does not bounce while in operation.

**NOTE:**

Changes may have been made to the combine controls or the display since this document was published. For the most up-to-date information, refer to the combine operator’s manual.

## AUTO HEADER HEIGHT CONTROL SYSTEM

1. Ensure that indicator (A) is at position **0** (B) when the header is 254–356 mm (10–14 in.) off the ground. If it is not, check the float sensor output voltage. For instructions, refer to [3.11.1 Checking Voltage Range from Combine Cab – Gleaner® R65, R66, R75, R76, and Pre-2016 S Series, page 383](#).

### NOTE:

When the header is on the ground, the indicator should be at position **1** (C) for low ground pressure, and at position **4** (D) for high ground pressure. Crop and soil conditions determine the amount of float to use. The ideal setting is as light as possible without the header bouncing or missing crop. Operating with heavy settings prematurely wears the cutterbar wearplates.

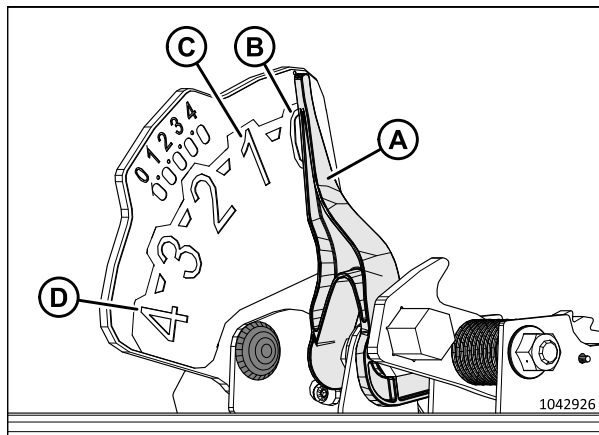


Figure 3.617: Float Indicator

2. Ensure that the header is in auto header height control (AHHC) mode. This is indicated by AUTO MODE LED light (A) displaying a continuous, solid light.
3. The header will lower to the height (ground pressure) corresponding to the position selected with height control knob (B). Turn the knob counterclockwise for minimum ground pressure and clockwise for maximum ground pressure.

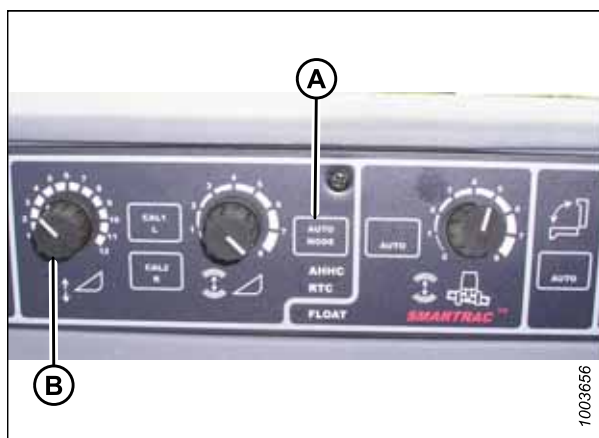


Figure 3.618: AHHC Console

### 3.11.7 Adjusting Auto Header Height Control Sensitivity – Gleaner® R65, R66, R75, R76, and Pre-2016 S Series

Auto header height control (AHHC) sensitivity refers to the distance that the cutterbar must travel up or down before the AHHC reacts and raises or lowers the feeder house.

### NOTE:

Changes may have been made to the combine controls or the display since this document was published. For the most up-to-date information, refer to the combine operator's manual.

## AUTO HEADER HEIGHT CONTROL SYSTEM



**Figure 3.619: Auto Header Height Control Console**

SENSITIVITY ADJUSTMENT dial (A) controls the distance the cutterbar must travel up or down before the AHHC reacts and raises or lowers the feeder house.

When SENSITIVITY ADJUSTMENT dial (A) is set to maximum (turned completely clockwise), only small changes in ground height are needed to cause the feeder house to raise or lower. In this position, the cutterbar moves up and down approximately 19 mm (3/4 in.) before the control module signals the hydraulic control valve to raise or lower the header frame.

When SENSITIVITY ADJUSTMENT dial (A) is set to minimum (turned completely counterclockwise), large changes in ground height are needed to cause the feeder house to raise or lower. In this position, the cutterbar moves up and down approximately 51 mm (2 in.) before the control module signals the hydraulic control valve to raise or lower the header frame.

The HEADER SENSE LINE input also changes the range of the sensitivity. When connected to a draper, the counterclockwise position (least sensitive) allows for approximately 102 mm (4 in.) of vertical travel before correction is made.

### **3.11.8 Troubleshooting Alarms and Diagnostic Faults – Gleaner® R65, R66, R75, R76, and Pre-2016 S Series**

Refer to this section to learn the meaning of the alarms and faults related to the auto header height control (AHHC) system. Alarms and diagnostic faults are displayed on the combine's electronic instrument panel (EIP).

**NOTE:**

Changes may have been made to the combine controls or the display since this document was published. For the most up-to-date information, refer to the combine operator's manual.

## AUTO HEADER HEIGHT CONTROL SYSTEM

### Display type:

Displayed on tachometer (A) as XX or XXX.



Figure 3.620: Tachometer

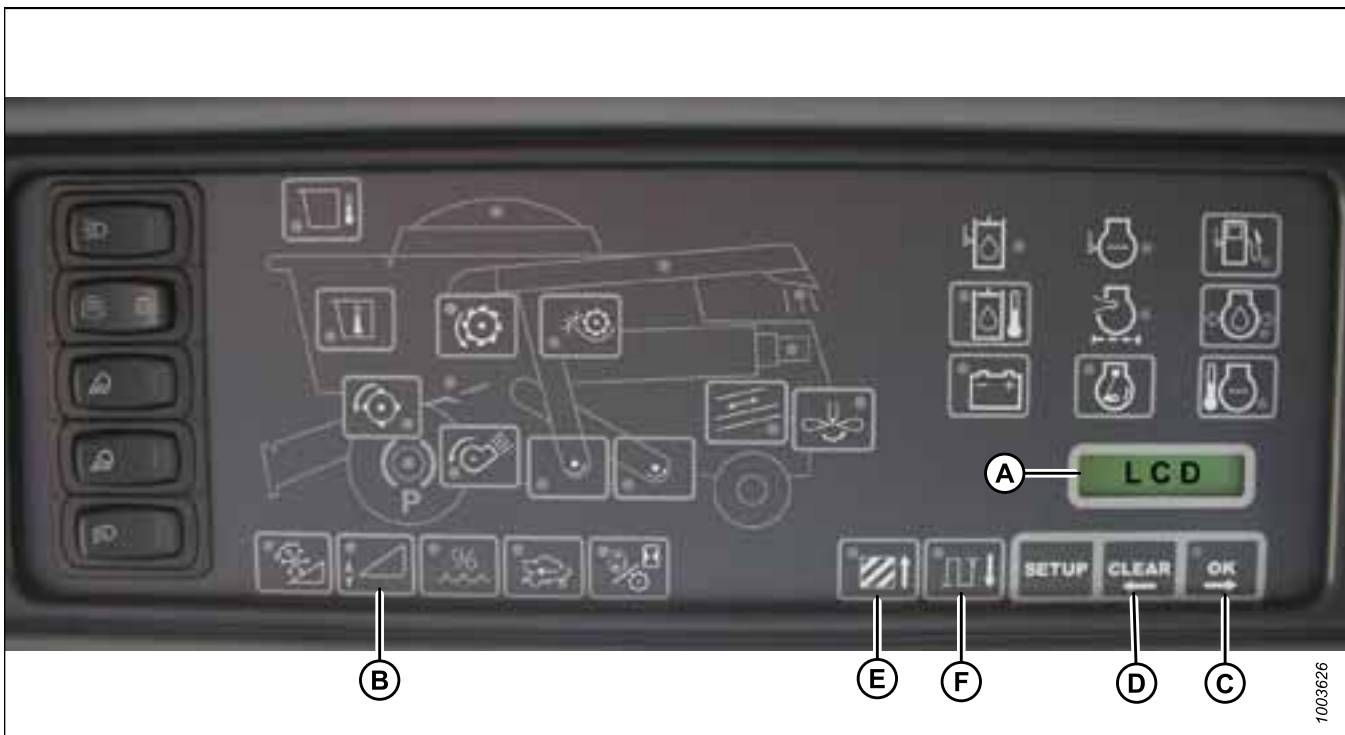


Figure 3.621: Combine Electronic Instrument Panel (EIP)

### NOTE:

Displayed on LCD (A) as XX in. or XXX cm.

### Alarm conditions:

If an error message is received from the fuse panel, an alarm sounds. The alarm buzzer sounds five times every 10 seconds. LCD (A) on the electronic instrument panel (EIP) indicates the header system in error as HDR CTRL followed by HGT ERR for height, and HDR CTRL followed by TILT ERR for tilt. The header height LED flashes yellow two times every second.

When an alarm condition occurs, a green LED flashes (green, yellow, or red depending on the input). In addition, a message is displayed on the LCD to identify the nature of the alarm. For example, HYD TEMP, OPEN, SHRT will be flashed alternately.

### Diagnostic fault failures:

Refer to Figure 3.621, page 394.

## AUTO HEADER HEIGHT CONTROL SYSTEM

Pressing header height switch (B) for a minimum of 5 seconds will put the EIP in header diagnostic mode. The LCD (shown on previous screen) will display the message HDR DIAG when the EIP has entered header diagnostic mode.

In this mode, after 3 seconds, header fault parameter labels are displayed on the EIP LCD. All the information displayed is read-only.

OK (C) and CLEAR (D) buttons allow you to scroll through the list of parameters. If there are no active fault codes, the EIP LCD will display NO CODE.

When a parameter is displayed, its label is displayed for 3 seconds, after which its value is automatically displayed.

Pressing OK button (C) while the value is displayed will advance to the next parameter and display its label.

When a parameter label is displayed and OK button (C) is pressed before 3 seconds, the parameter's value will be displayed.

Pressing AREA (E) will cycle through the options. When LEFT is displayed on the LCD, press OK button (C), and the auto header height control (AHHC) voltage will be shown on the display.

Press DIST button (F) to cycle back through the table.

Press CLEAR button (D) to exit header diagnostics and return to normal mode.



### 3.12 Gleaner® S9 Series Combines

To make your header’s auto header height control (AHHC) system compatible with the combine, configure the reel speed settings, set up the AHHC controls, and calibrate the AHHC system to ensure that it is working correctly.

#### 3.12.1 Setting up Header – Gleaner® S9 Series

To set up a header to work with the auto header height control (AHHC) system, you will need to access the HEADER SETTINGS menu using the Tyton terminal.

**NOTE:**

Changes may have been made to the combine controls or the display since this document was published. For the most up-to-date information, refer to the combine operator’s manual.

AGCO Tyton terminal (A) is used to set up and manage a MacDon header on Gleaner® S9 Series Combines. Use the touch screen display to select the desired item on the page.



**Figure 3.622: Operator’s Station – Gleaner® S9**  
 A - Tyton Terminal    B - Control Handle  
 C - Throttle         D - Header Control Cluster

1. On the top right quadrant of the home page, select COMBINE icon (A). The COMBINE MAIN MENU opens.



**Figure 3.623: Combine Icon on Home Page**



## AUTO HEADER HEIGHT CONTROL SYSTEM

2. On the COMBINE MAIN MENU, select HEADER SETTINGS (A). The HEADER SETTINGS page appears.

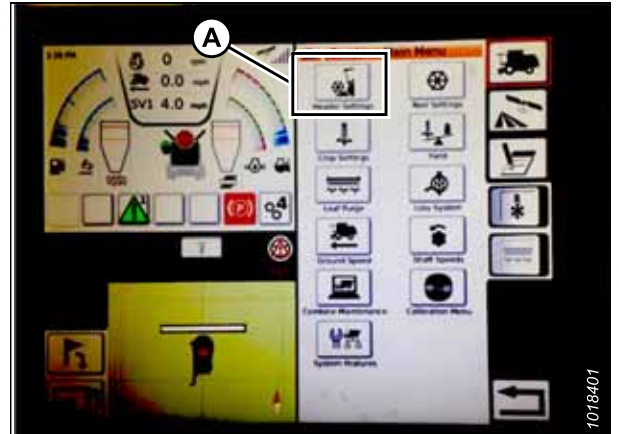
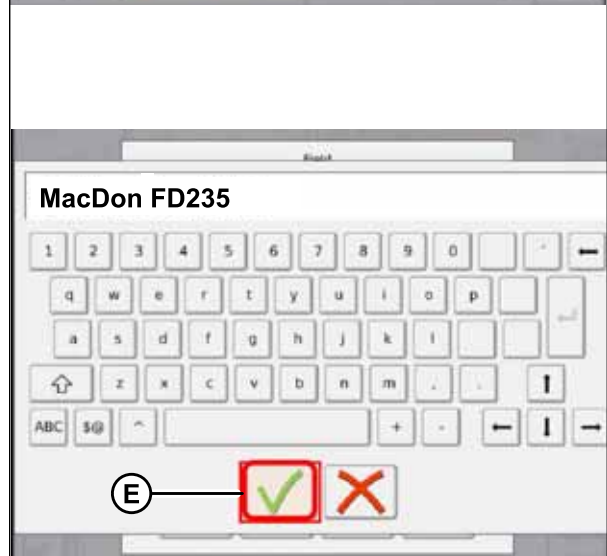
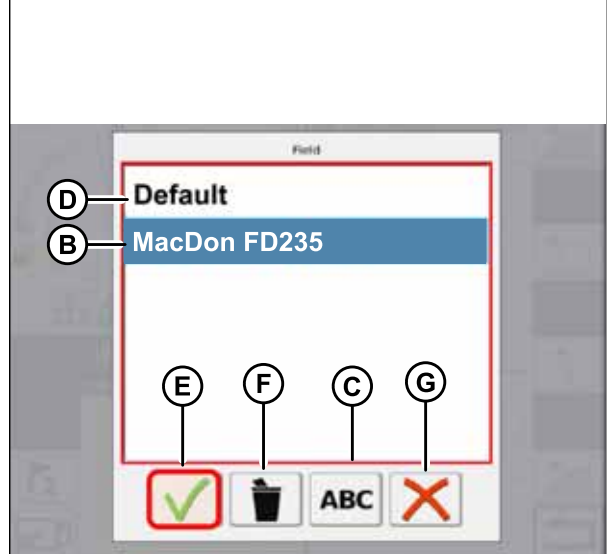
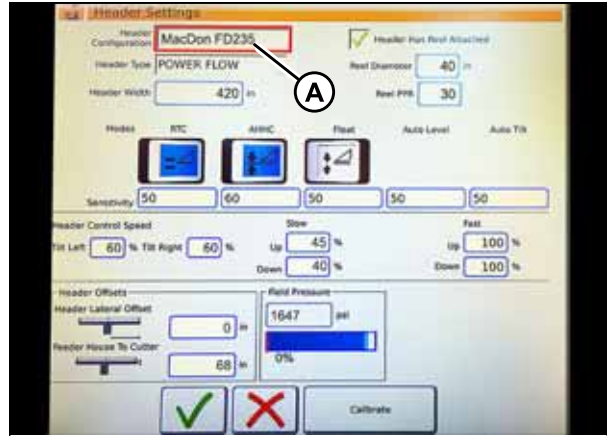


Figure 3.624: Header Settings in Combine Main Menu

## AUTO HEADER HEIGHT CONTROL SYSTEM

3. Select HEADER CONFIGURATION field (A). A list of headers appears.
  - If your MacDon header is already set up, it should appear on the header list. Select MacDon header (B) to highlight the header in blue, then select green check mark (E) to continue.
  - If only DEFAULT header (D) is shown, select ABC button (C) and use the on-screen keyboard to enter the MacDon header information. After entering the information, select one of the following options to return to the HEADER SETTINGS page:
    - Green check mark (E) saves the settings
    - Garbage can icon (F) deletes the highlighted header from the list
    - Red X (G) cancels the change(s)



1035985

**Figure 3.625: Header Configuration Menu on Header Settings Page**

## AUTO HEADER HEIGHT CONTROL SYSTEM

- To specify the type of header installed on the machine, select HEADER TYPE field (A). A list of header types appears.

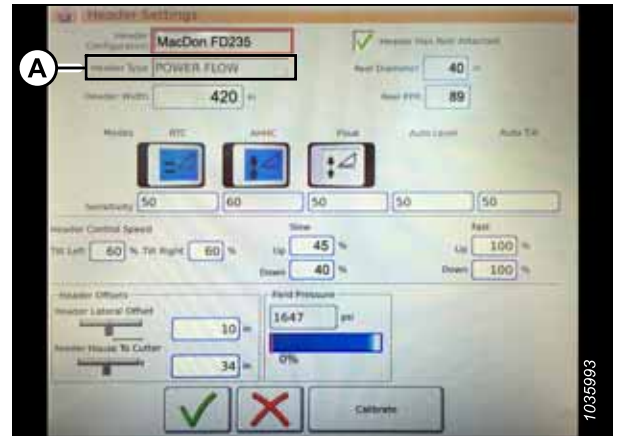


Figure 3.626: Header Settings

- Select POWER FLOW (A). Select green check mark (B) to save the selection.

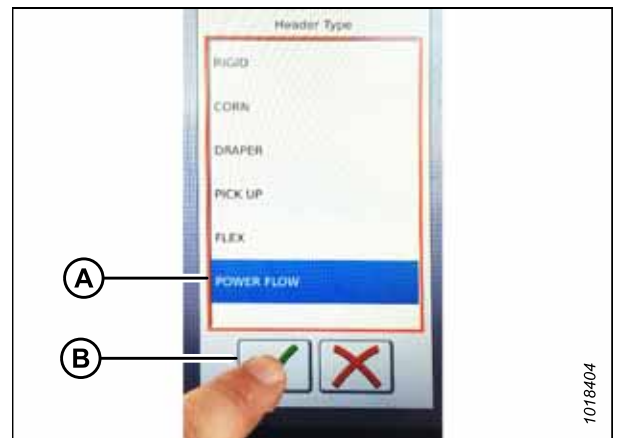


Figure 3.627: Header Type

- Ensure that HEADER HAS REEL ATTACHED check box (A) is checked.

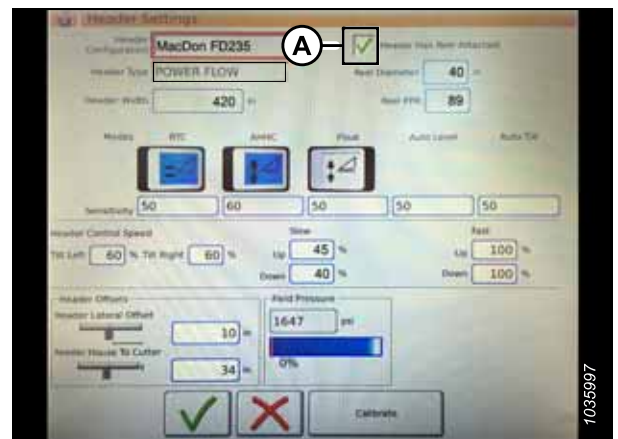
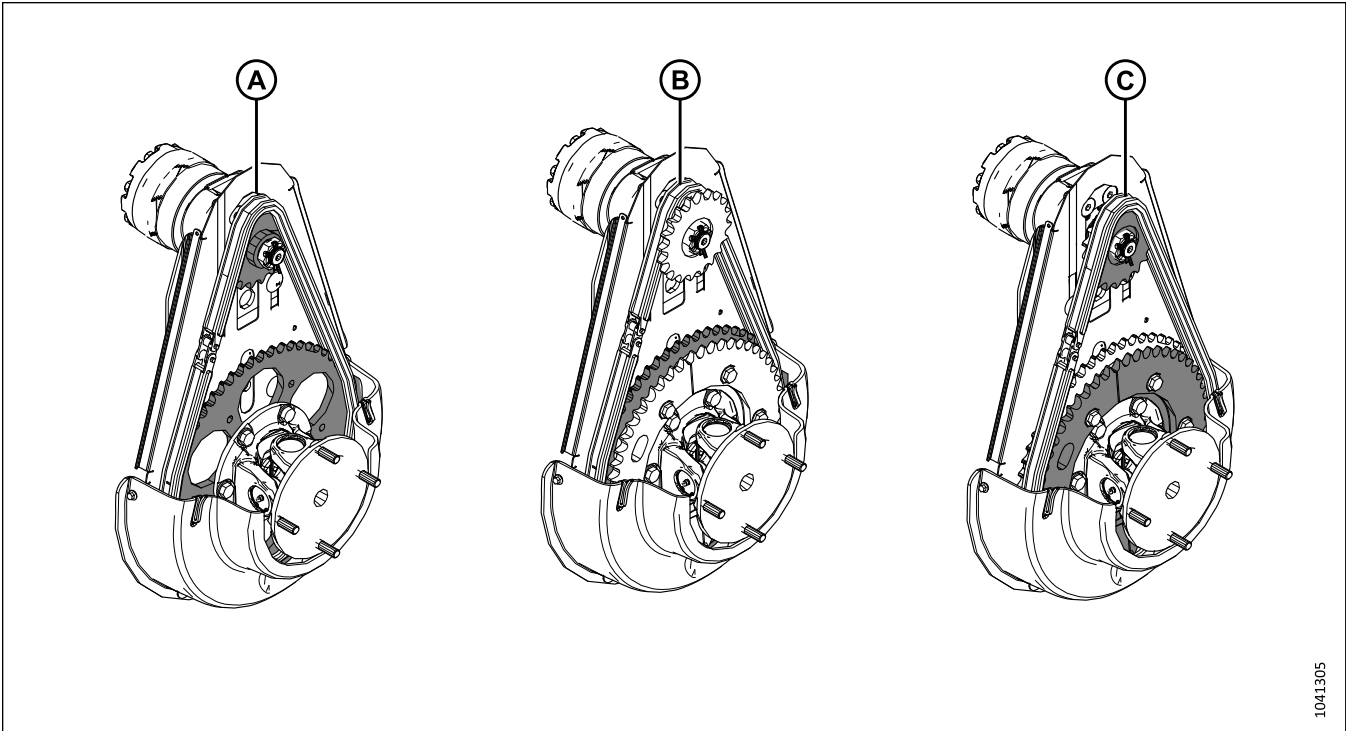


Figure 3.628: Header Settings

## AUTO HEADER HEIGHT CONTROL SYSTEM



1041305

**Figure 3.629: Reel Drive Configurations**

7. If the type of reel drive configuration installed on the header is not already known, identify it as follows:

- (A) Standard configuration: One set of sprockets is installed.
- (B) High torque/low speed: The chain is installed on the inner set of sprockets.
- (C) High speed/low torque: The chain is installed on the outer set of sprockets.

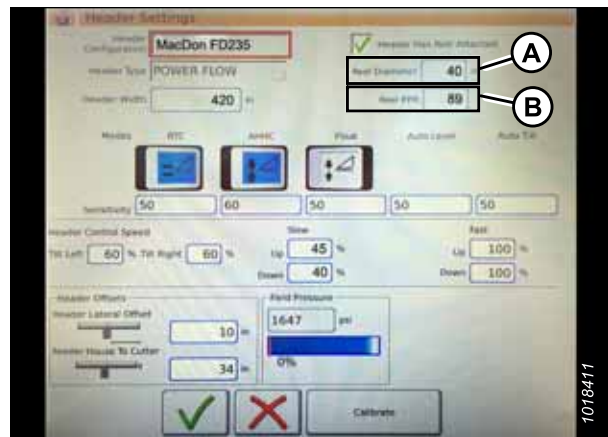
8. Select REEL DIAMETER field (A) and a numeric keypad displays. Enter **40** for a MacDon reel.

9. Select REEL PPR (pulses per revolution) field (B). Enter the value according to the type of reel drive sprocket configuration identified in Step 7, [page 400](#):

- Standard configuration: **192**
- High torque/low speed: **303**
- Low torque/high speed: **169**

**NOTE:**

When AHHC is enabled, the reel should move slightly faster than the combine's ground speed. If the reel moves faster or slower than desired with the above PPR setting, contact your Dealer for assistance.



1018411

**Figure 3.630: Header Settings**

## AUTO HEADER HEIGHT CONTROL SYSTEM

10. Select green check mark (B) below numeric keypad (A).

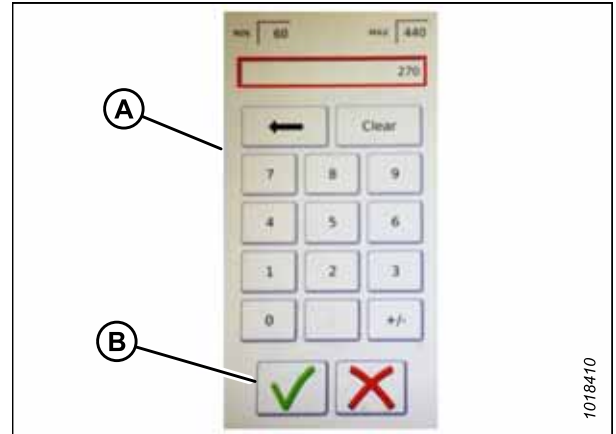


Figure 3.631: Numeric Keypad

11. Select green check mark (A) at the bottom of the HEADER SETTINGS page.

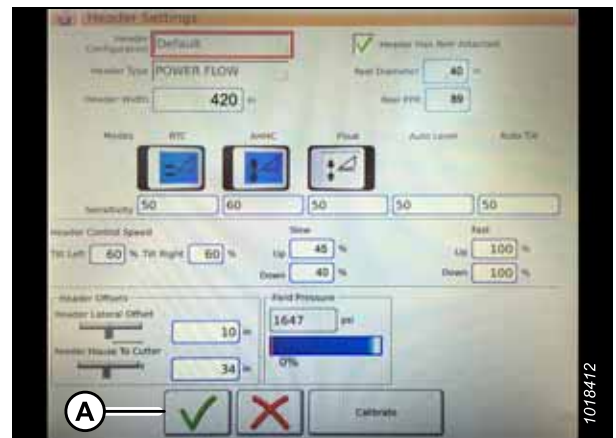


Figure 3.632: Header Settings Page

### 3.12.2 Setting Minimum Reel Speed and Calibrating Reel – Gleaner® S9 Series

To set up the header's minimum reel speed to work with the auto header height control (AHHC) system and to calibrate the reel, access the REEL SETTINGS menu.

#### DANGER

Ensure that all bystanders have cleared the area.

#### NOTE:

Changes may have been made to the combine controls or the display since this document was published. For the most up-to-date information, refer to the combine operator's manual.

## AUTO HEADER HEIGHT CONTROL SYSTEM

1. From the COMBINE MAIN MENU, select REEL SETTINGS (A). The REEL SETTINGS page opens.



Figure 3.633: Reel Settings on Combine Main Menu

2. To set the minimum reel speed, select SPEED MINIMUM FIELD (B). The on-screen keyboard appears.
3. Input the desired value. Select the green check mark to enter the new value or select the red X to cancel input. The reel speed is shown in mph and rpm.

### NOTE:

At the bottom of the REEL SETTINGS page, the reel diameter and the reel pulses per revolution (PPR) are displayed. These values have already been set in the HEADER SETTINGS page.

4. To calibrate the reel speed, select CALIBRATE button (A) in the top right of the page. The CALIBRATION WIZARD opens and displays a hazard warning.
5. Review the conditions listed in the CALIBRATION WIZARD warning and ensure that all of the conditions are met. Press green check mark (A) to accept and start calibration. Pressing red X (B) will cancel the calibration procedure.



Figure 3.634: Reel Settings Calibration

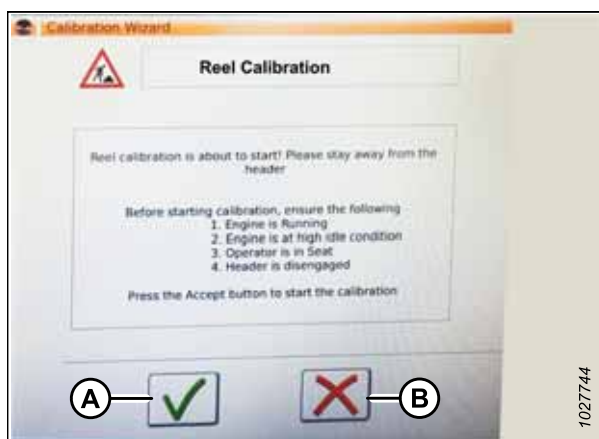


Figure 3.635: Calibration Wizard



## AUTO HEADER HEIGHT CONTROL SYSTEM

- A message appears in the CALIBRATION WIZARD stating that reel calibration has started. The reel will begin turning slowly and increase in speed. If necessary, select the red X at the bottom of the screen to cancel the calibration process. Otherwise, wait for the message that reel calibration has completed successfully.
- Select the green check mark at the bottom of the screen to save the calibrated settings.



Figure 3.636: Calibration Progress

### 3.12.3 Setting up Automatic Header Controls – Gleaner® S9 Series

You can configure automatic header functions on the HEADER SETTINGS page.

#### NOTE:

Changes may have been made to the combine controls or the display since this document was published. For the most up-to-date information, refer to the combine operator's manual.

- Automatic control functions:** There are toggle (OFF/ON) switches on the HEADER SETTINGS page for the automatic control functions. For MacDon headers, ensure that the following two functions are enabled as shown:

- RTC (return to cut) (A)
- AHHC (automatic header height control) (B)

All other switches are disabled (not highlighted).

- Sensitivity:** Setting (C) controls how responsive a control (RTC or AHHC) is to a given change in sensor feedback. The setting fields are located directly below the toggle switches. To enter a new sensitivity setting, touch the setting field below the specific toggle switch, and enter the new value in the on-screen keyboard.

- Increase the sensitivity if the combine does not change the feeder position quickly enough when in Auto Mode.
- Decrease the sensitivity if the combine hunts for a position in Auto Mode.

#### NOTE:

The sensitivity starting points for MacDon headers are as follows:

- **50** for RTC (A)
- **60** for AHHC (B)

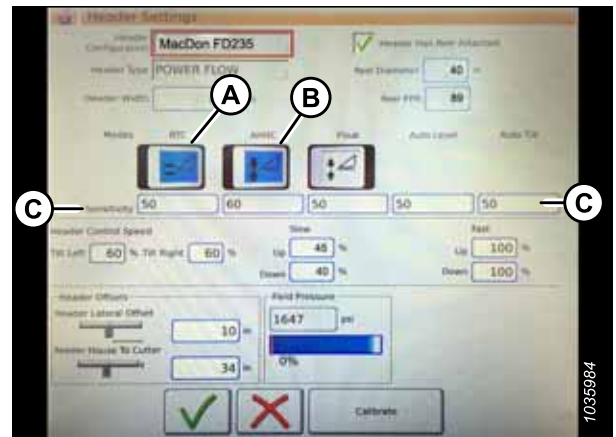


Figure 3.637: Automatic Controls and Sensitivity Settings

## AUTO HEADER HEIGHT CONTROL SYSTEM

3. **Header speed:** HEADER CONTROL SPEED area (A) on the HEADER SETTINGS page is used to adjust the following speeds:

- Tilt left and right is the lateral tilt of the combine faceplate.
- Header up and down (slow and fast speeds) is a two-stage button with slow speed on the first detent and fast on the second.

### NOTE:

The control speed starting points for MacDon headers are as follows:

- Slow: 45 up / 40 down
- Fast: 100 up / 100 down

4. **Header offsets (A):** Offset distances are important for yield mapping. There are two adjustable dimensions on the HEADER SETTINGS page:

- Header Lateral Offset: the distance between the centerline of the header and the centerline of the machine. Set to **0** for a MacDon header.
- Feeder House to Cutter: the distance from the machine interface to the cutterbar. Set to **68** for a MacDon header.

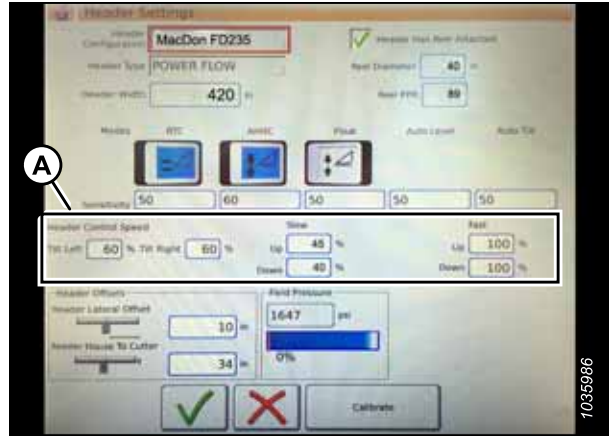


Figure 3.638: Header Speed Control Settings

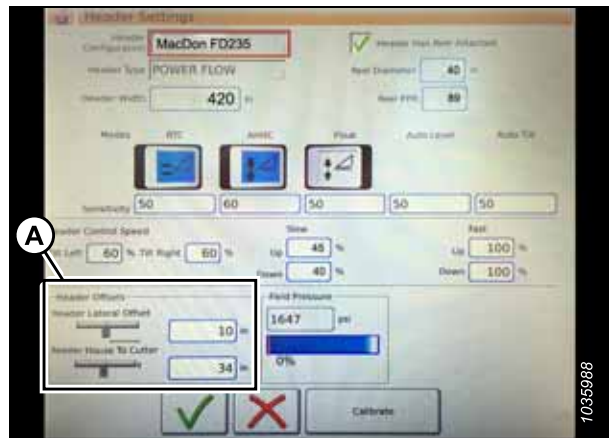


Figure 3.639: Header Offset Settings



## AUTO HEADER HEIGHT CONTROL SYSTEM

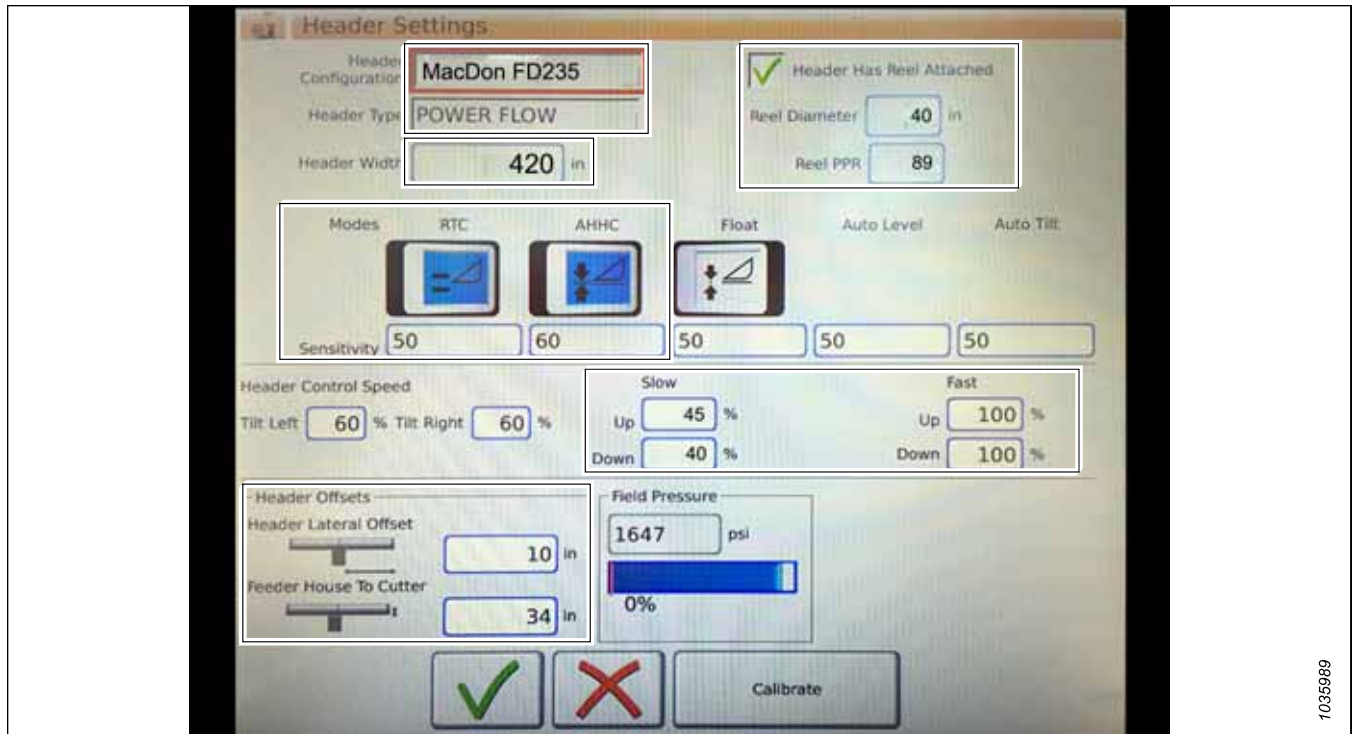


Figure 3.640: MacDon Header Settings Inputs

### 3.12.4 Calibrating Auto Header Height Control – Gleaner® S9 Series

The auto header height control (AHHC) sensor output must be calibrated for each combine, or the AHHC feature will not work properly.

#### DANGER

To prevent bodily injury or death from the unexpected start-up of the machine, always stop the engine and remove the key from the ignition before making adjustments to the machine.

#### DANGER

Ensure that all bystanders have cleared the area.

#### NOTE:

Changes may have been made to the combine controls or the display since this document was published. For the most up-to-date information, refer to the combine operator's manual.

#### NOTE:

If the header float is set too light, it can prevent the calibration of the AHHC. In order to prevent the header from separating from the float module, it may be necessary to change the float to a heavier setting during calibration.

## AUTO HEADER HEIGHT CONTROL SYSTEM

1. Park the combine on a level surface.
2. Ensure that the header is level with the ground. If adjustment is required:
  - Ensure that the combine is parked on a level surface.
  - If equipped, use the combine's lateral tilt to level the feeder house with the ground.
  - If further adjustment is required, shut the engine off, remove the key from the ignition, and ensure that the combine's tires are inflated to the correct pressure.

### NOTE:

Spirit level (A) is located on top of the float module frame. The header is level if the bubble is in the center of the spirit level.

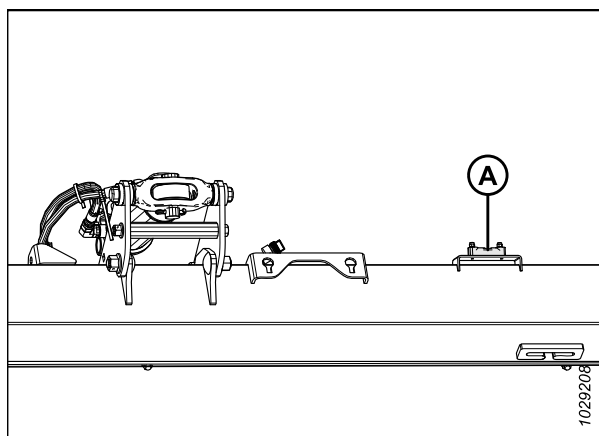


Figure 3.641: Spirit Level

3. Ensure that the center-link is set to **D**.

### NOTE:

When calibration is complete, adjust the center-link back to the desired header angle. For instructions, refer to [3.9.5 Header Angle, page 232](#).

4. Adjust the reel fore-aft position so that the indicator is at position **6**.
5. Position the header so that the cutterbar is 254–356 mm (10–14 in.) off the ground.
6. Shut down the engine, and remove the key from the ignition.

## AUTO HEADER HEIGHT CONTROL SYSTEM

### CAUTION

To prevent cuts, pinches, and other bodily harm to the person checking the down stops, ensure that nobody is manually lifting, bouncing, or moving the header in any way while the down stop washer is being touched and checked for movement.

7. Ensure that the float lock linkage is on the down stops (washer [A] cannot move) at both locations.

#### NOTE:

If the header is **NOT** on the down stops, the voltage may go out of range during operation and cause the AHHC system to malfunction. To fix the problem, make the header heavier by decreasing the float. For instructions, refer to [Checking and Adjusting Header Float, page 210](#).

8. Unlock the header float. For instructions, refer to [Locking / Unlocking Header Float, page 221](#).
9. Lock the header wings. For instructions, refer to [Operating in Rigid Mode, page 224](#).

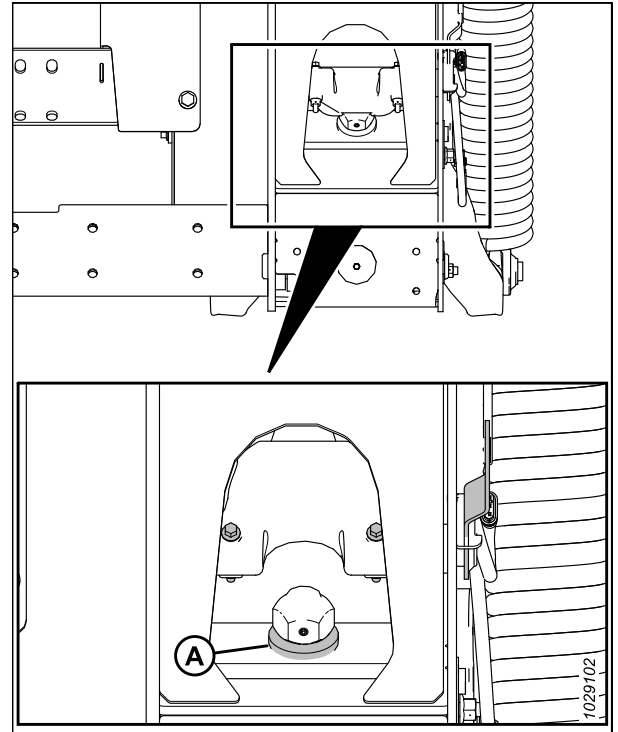


Figure 3.642: Down Stop Washer

10. On the COMBINE MAIN MENU, select HEADER SETTINGS icon (A).



Figure 3.643: Combine Main Menu

## AUTO HEADER HEIGHT CONTROL SYSTEM

11. Select CALIBRATE (A) at the bottom right of the page. The HEADER CALIBRATION page appears.

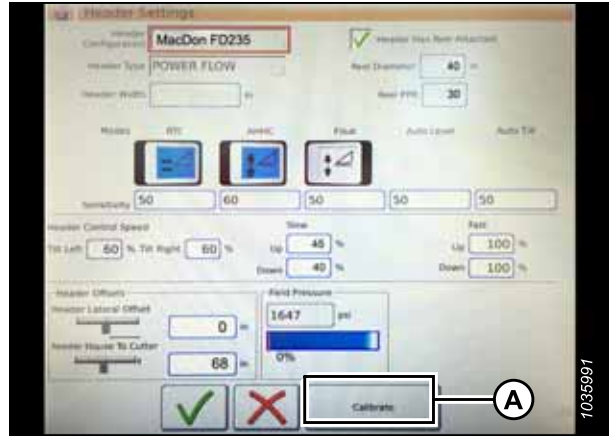


Figure 3.644: Header Settings Page

The right side of the page shows HEADER CALIBRATION information (A). The information is shown for a list of sensors (B):

- Left and right header sensor (voltage) (values will be the same with MacDon headers)
- Header height sensor (mA)
- Tilt position sensor (mA)

The following valid modes are shown with check marks (C) below sensor values (B):

- Return to cut
- Automatic header height control

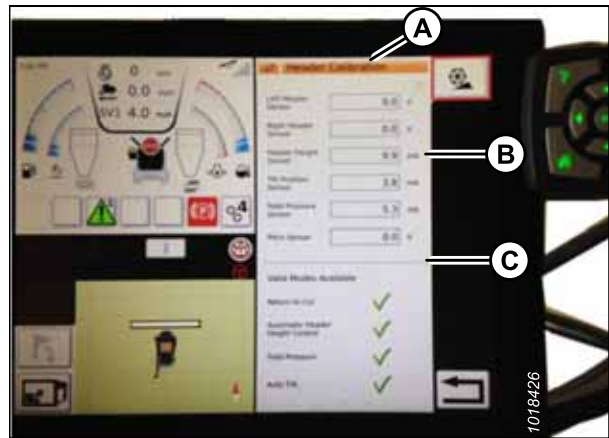


Figure 3.645: Header Calibration Page

12. On the control handle, press HEADER DOWN button (A). The sensor values on the HEADER CALIBRATION page will change as the header falls.



Figure 3.646: Header Down Switch

## AUTO HEADER HEIGHT CONTROL SYSTEM

13. Select CALIBRATE icon (A).



Figure 3.647: Header Calibration

14. The hazard warning for HEADER CALIBRATION appears. Ensure that all of the conditions are met.
15. Select the green check mark at the bottom of the screen to start the CALIBRATION WIZARD.



Figure 3.648: Header Calibration Warning

A progress bar displays at the bottom of the screen. The header will move automatically and erratically during calibration; you can stop the process at any time by selecting the red X below the progress bar.

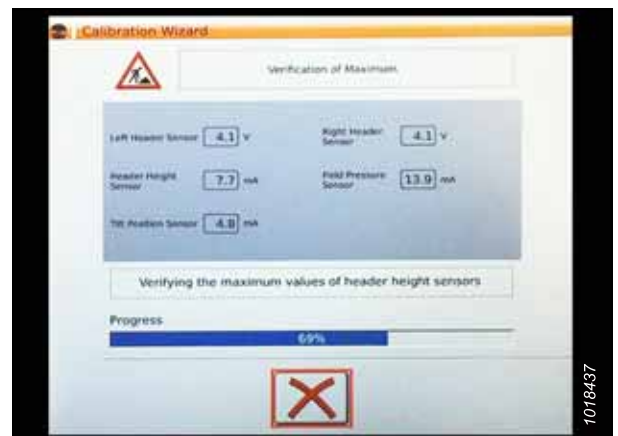


Figure 3.649: Calibration in Progress

## AUTO HEADER HEIGHT CONTROL SYSTEM

16. When the calibration process is complete, a message will appear, showing information (A). The green check marks indicate that functions (B) have been calibrated. Select green check mark (C) at the bottom of the screen to exit the calibration page.



Figure 3.650: Completed Calibration Page

### NOTE:

Select CALIBRATION icon (A) on the COMBINE MAIN MENU page. The CALIBRATION MENU appears. On the CALIBRATION MENU, you can calibrate several other features, such as the header and the reel.



Figure 3.651: Direct Calibration Menu

### 3.12.5 Operating Auto Header Height Control – Gleaner® S9 Series

Once the auto header height control (AHC) system has been set up, you can engage the AHC system and fine-tune the position of the header by using a control dial.

### NOTE:

Changes may have been made to the combine controls or the display since this document was published. For the most up-to-date information, refer to the combine operator's manual.



## AUTO HEADER HEIGHT CONTROL SYSTEM

The following controls are used to operate the AHHC functions:

- Tyton terminal (A)
- Control handle (B)
- Throttle (C)
- Header control cluster (D)

Use the combine operator's manual to familiarize yourself with the controls.



Figure 3.652: Gleaner® S9 Operator Controls

1. With the header running, set lateral tilt switch (A) to MANUAL.
2. Engage the AHHC by pressing switch (B) to the upward position.



Figure 3.653: Header Control Cluster

3. Press AHHC control switch (A) on the control handle to engage the AHHC. The header moves to the current set point position.

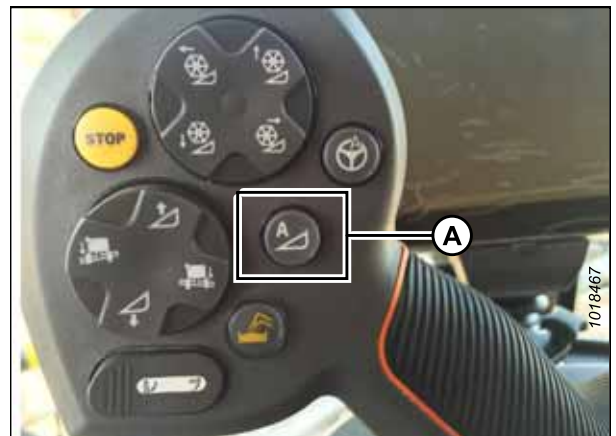


Figure 3.654: AHHC on Control Handle

## AUTO HEADER HEIGHT CONTROL SYSTEM

4. Use HEADER HEIGHT SETPOINT control dial (A) as necessary to fine-tune the position.



Figure 3.655: Header Control Cluster

### 3.12.6 Reviewing Header In-Field Settings – Gleaner® S9 Series

You can review the auto header height control (AHHC) settings by pressing the HEADER icon on the Tyton terminal's home page.

**NOTE:**

Changes may have been made to the combine controls or the display since this document was published. For the most up-to-date information, refer to the combine operator's manual.

1. To view the following header group settings, select HEADER icon (A) on the right side of the home page:

- CURRENT POSITION of header (B).
- SETPOINT cut-off position (C) (indicated by the red line)
- HEADER symbol (D) – select to adjust the set point cut-off position using the scroll wheel on the right side of the Tyton terminal.
- CUT HEIGHT for AHHC (E) – fine-tune with the header height set point control dial on the header control cluster.
- HEADER WORKING WIDTH (F)
- HEADER PITCH (G)

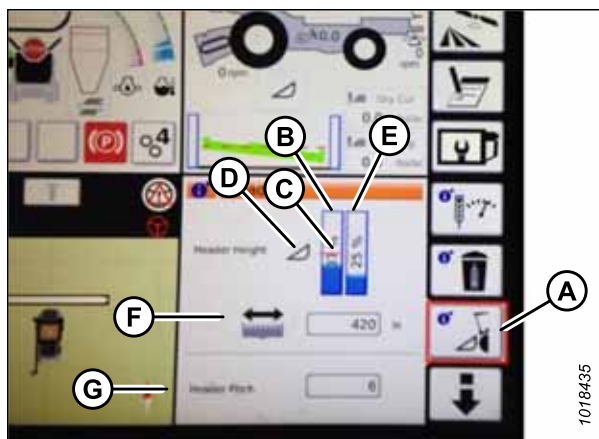


Figure 3.656: Header Groups

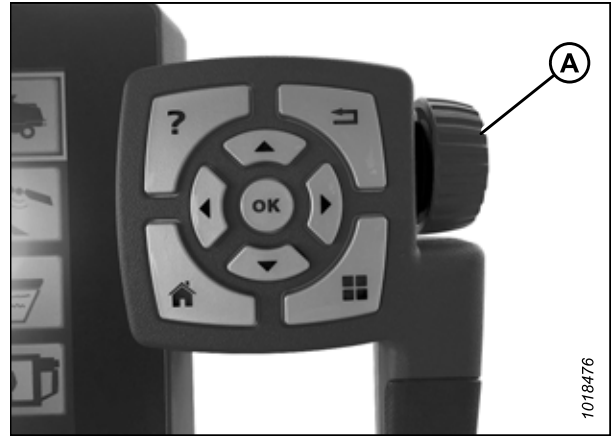


## AUTO HEADER HEIGHT CONTROL SYSTEM

2. Selecting a field opens the on-screen keyboard, so that the values can be adjusted. Enter the new value and select the green check mark when complete.

**NOTE:**

Scroll wheel (A) is located on the right side of the Tyton terminal.



**Figure 3.657: Adjustment Wheel on Right Side of Tyton Terminal**

**NOTE:**

HEADER HEIGHT SETPOINT control dial (A) is on the header control cluster.



**Figure 3.658: Header Control Cluster**

### 3.12.7 Header Settings Quick Reference – Gleaner® S9 Series

The recommended auto header height control (AHHC) settings for an FD2 Series FlexDraper® Header operating with a Gleaner® S9 Series combine are provided.

**Table 3.43 Header Settings – Gleaner® S9 Series**

Setup Parameter	Suggested Setting
Header type	Power Flow
Header has reel attached check box	Checked
Reel diameter	40
Reel PPR <sup>77</sup>	192
Sensitivity (RTC)	50
Sensitivity (AHHC)	60
Header control speed <sup>78</sup>	Slow: Up 45/Down 40 Fast: Up 100/Down 100

77. Pulses per revolution.

78. A two-stage button with slow speed on the first detent and fast on the second.

## AUTO HEADER HEIGHT CONTROL SYSTEM

**Table 3.43 Header Settings – Gleaner® S9 Series (continued)**

Setup Parameter	Suggested Setting
Header lateral offset	0
Feeder house to cutter	68

### 3.13 IDEAL™ Series Combines

To make your header’s auto header height control (AHHC) system compatible with the combine, configure the reel speed settings, set up the AHHC controls, and calibrate the AHHC system to ensure that it is working correctly.

#### 3.13.1 Header Settings Quick Reference – IDEAL™ Series

The recommended auto header height control (AHHC) settings for a header operating with an IDEAL™ Series combine are provided.

For detailed instructions, proceed to the IDEAL™ combine header setup and calibration procedures.

**Table 3.44 Header Settings – IDEAL™**

Setup Parameter	Suggested Setting		
Header type	Power Flow		
Reel check box	Checked		
Reel diameter	102 cm (40 in.) <sup>79</sup>		
Reel PPR <sup>80</sup>	Standard - 38	High-torque sprocket - 61	High-speed sprocket - 34
Sensitivity (RTC)	50		
Sensitivity (AHHC)	60		
Header control speed <sup>81</sup>	Slow: Up 45/Down 40 Fast: Up 100/Down 100		
Header lateral offset	0		
Feeder house to cutter	68		

#### 3.13.2 Setting up Header – IDEAL™ Series

Set these initial configuration options on your IDEAL™ Series combine when setting up the auto header height control (AHHC) system.

**NOTE:**

Changes may have been made to the combine controls or the display since this document was published. For the most up-to-date information, refer to the combine operator’s manual.

79. If the reel speed does not index correctly, then the reel diameter can be increased to 112 cm (44 in.).

80. Pulses per revolution.

81. A two-stage button with slow speed on the first detent and fast on the second.

## AUTO HEADER HEIGHT CONTROL SYSTEM

Tyton terminal (A) is used to set up and manage a MacDon header on an IDEAL™ Series combine. Use the touch screen display to select the desired item on the page.



Figure 3.659: IDEAL™ Series Operator's Station

A - Tyton Terminal    B - Control Handle  
C - Throttle            D - Header Control Cluster

1. On the top right of the home page, select COMBINE icon (A). The COMBINE MAIN MENU opens.

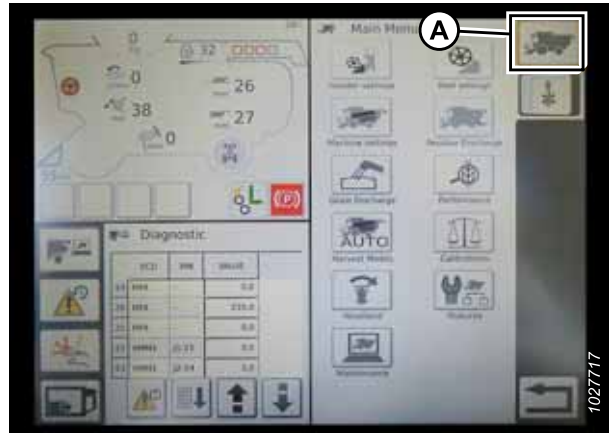


Figure 3.660: Combine Icon on Home Page

2. On the COMBINE MAIN MENU, select HEADER SETTINGS (A). The HEADER SETTINGS page opens.

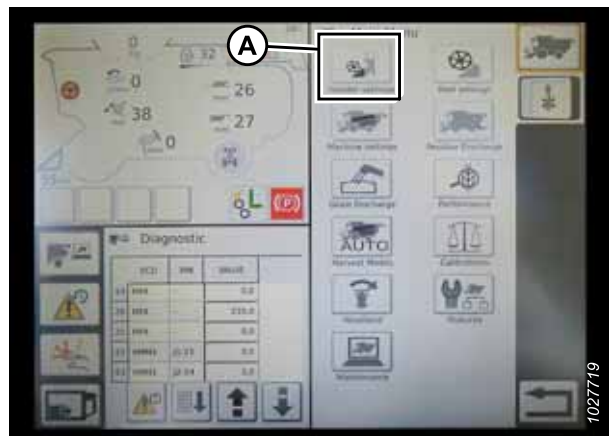
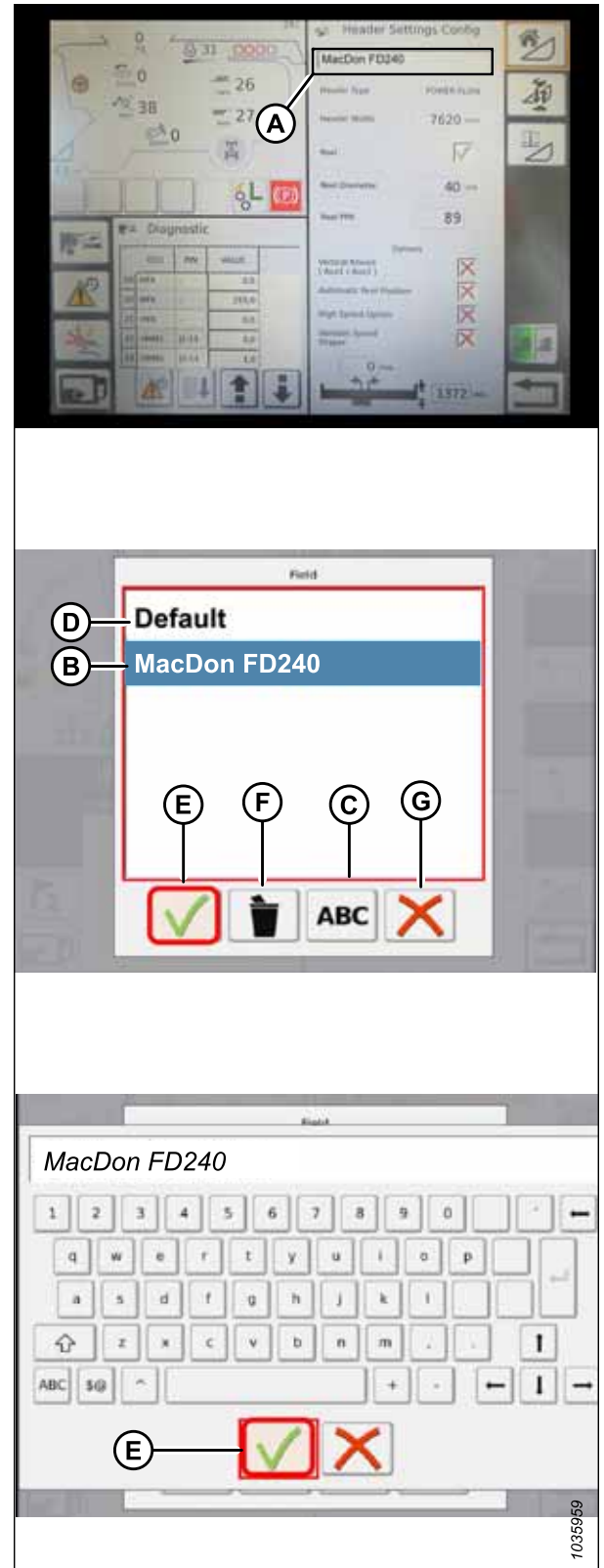


Figure 3.661: Header Settings in Combine Main Menu

## AUTO HEADER HEIGHT CONTROL SYSTEM

3. Select HEADER CONFIGURATION field (A). A list of headers appears.
  - If a MacDon header is already set up, it appears on the list. Select MacDon header title (B) to highlight the title in blue, then select green check mark (E) to continue setup.
  - If only DEFAULT header (D) is shown, select ABC button (C) and use the on-screen keyboard to enter the header information. After entering the information, select one of the following options to return to the HEADER SETTINGS page:
    - Green check mark (E) saves the settings
    - Garbage can icon (F) deletes the highlighted header from the list
    - Red X (G) cancels the change(s)



## AUTO HEADER HEIGHT CONTROL SYSTEM

- To specify the type of header installed on the machine, select HEADER TYPE field (A).

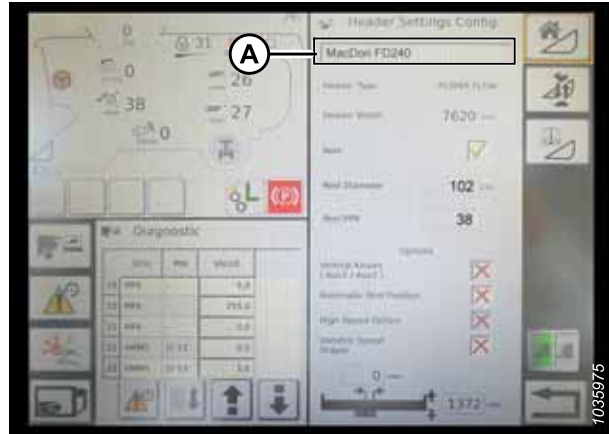


Figure 3.663: Header Settings

- From the list of predefined header types, select POWER FLOW (A).
- Select green check mark (B) to save the selection and continue.

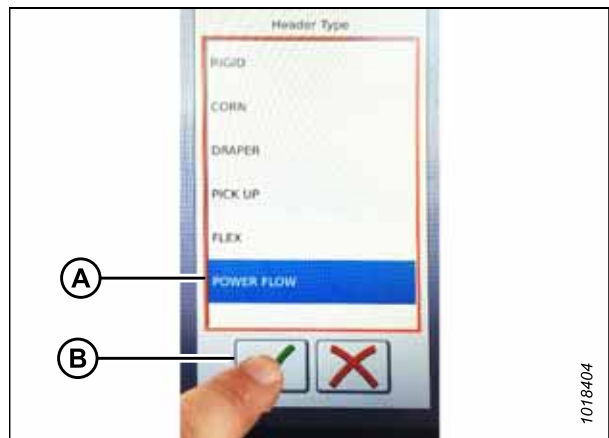


Figure 3.664: Header Type

- Ensure that REEL check box (A) is checked.

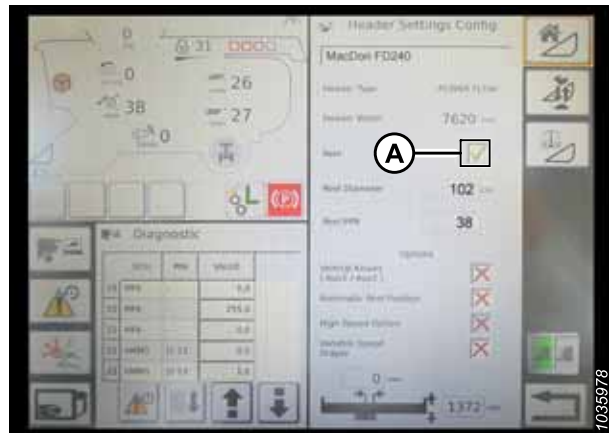
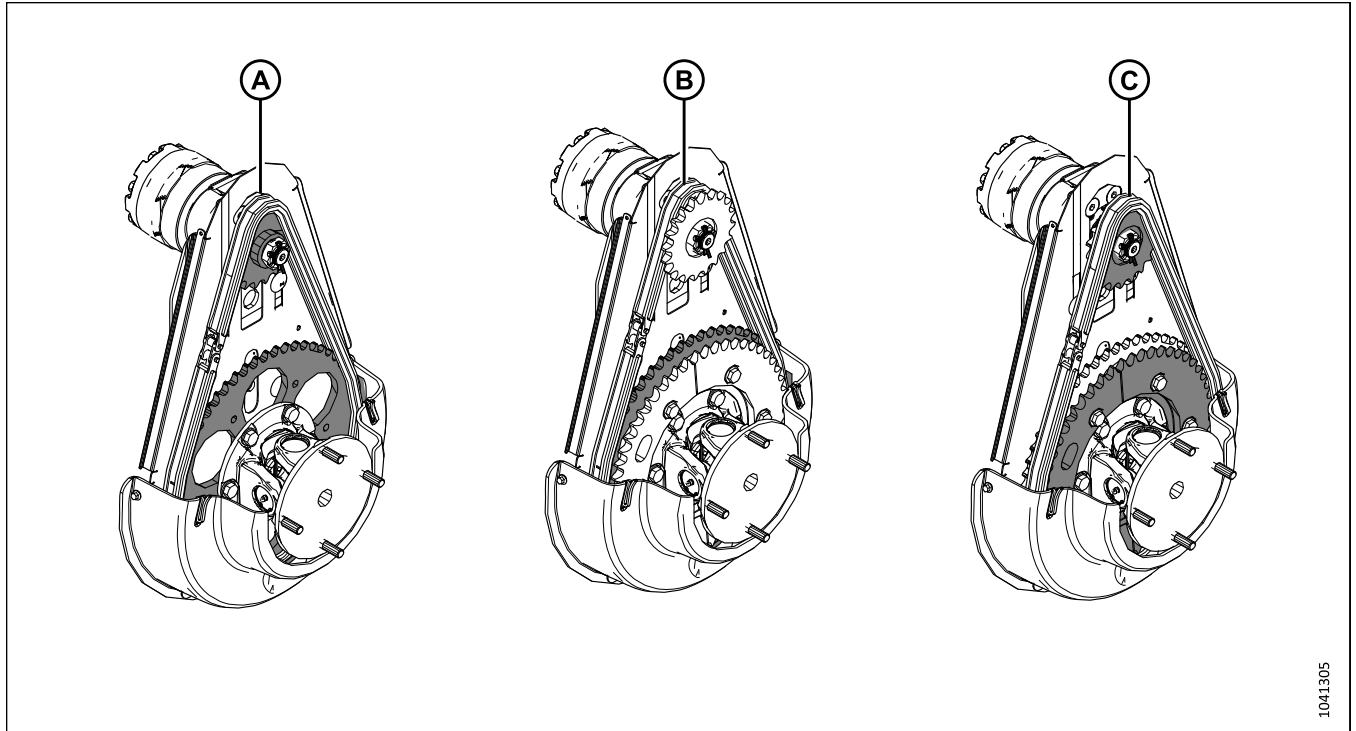


Figure 3.665: Header Settings

## AUTO HEADER HEIGHT CONTROL SYSTEM



**Figure 3.666: Reel Drive Configurations**

8. If the type of reel drive configuration installed on the header is not already known, identify it as follows:

- Standard configuration (A): One set of sprockets is installed.
- High torque/low speed (B): The chain is installed on the inner set of sprockets.
- High speed/low torque (C): The chain is installed on the outer set of sprockets.

9. Select REEL DIAMETER field (A). A numeric keypad appears. Enter the following value for a MacDon reel:

- 102 cm (40 in.)

**NOTE:**

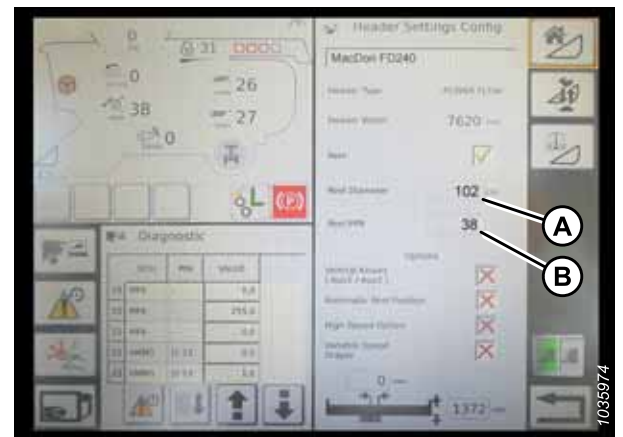
If the reel speed does not index correctly, then the reel diameter can be increased to 112 cm (44 in.).

10. Select REEL PPR (pulses per revolution) field (B) and enter the relevant value:

- Standard: 38
- High torque/low speed: 61
- High speed/low torque: 34

**NOTE:**

When AHHC is enabled, the reel should move slightly faster than the combine's ground speed. If the reel moves faster or slower than desired at the above PPR setting, contact your Dealer for assistance.



**Figure 3.667: Header Settings**

## AUTO HEADER HEIGHT CONTROL SYSTEM

11. Select green check mark (B) below numeric keypad (A).

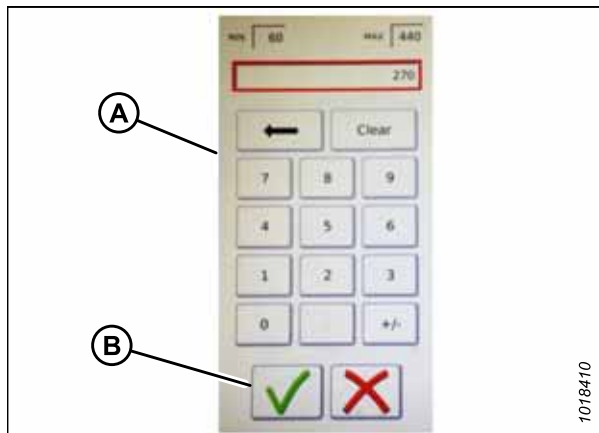


Figure 3.668: Numeric Keypad

12. Select green check mark (A) at the bottom of the HEADER SETTINGS page.

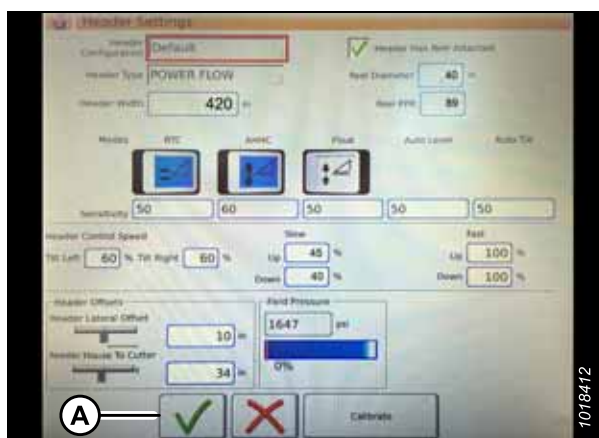


Figure 3.669: Header Settings Page

### 3.13.3 Setting Minimum Reel Speed and Calibrating Reel – IDEAL™ Series

To configure the reel speed on the header to work with the auto header height control system (AHHC) on an IDEAL™ Series combine, the reel operation parameters must be configured and the combine must run an automatic reel calibration procedure.

#### DANGER

Ensure that all bystanders have cleared the area.

#### NOTE:

Changes may have been made to the combine controls or the display since this document was published. Refer to the combine operator's manual for updated information.



## AUTO HEADER HEIGHT CONTROL SYSTEM

1. From the COMBINE MAIN MENU, touch REEL SETTINGS (A) to open the REEL SETTINGS page.

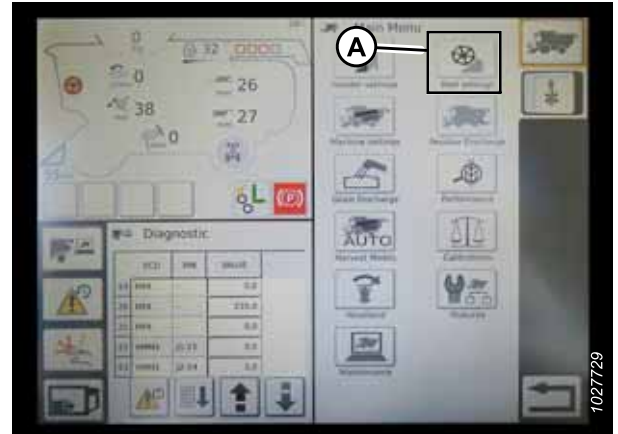


Figure 3.670: Reel Settings on Combine Main Menu

2. To set the minimum reel speed, touch SPEED MINIMUM FIELD (B). The on-screen keyboard appears. Enter the desired value. Select the green check mark to accept the new value, or the red X to cancel. The reel speed is shown in miles per hour (mph) and rotations per minute (rpm).

### NOTE:

The reel diameter and reel pulses per revolution (PPR) are displayed at the bottom of the REEL SETTINGS page. These values have already been set in the HEADER SETTINGS page.

3. Select CALIBRATE button (A) at the top right corner of the REEL SETTINGS page. The CALIBRATION WIZARD appears.
4. Ensure that all of the conditions listed in the CALIBRATION WIZARD warning have been met. Press the green check mark to start the reel calibration procedure. Pressing the red X will cancel the calibration procedure.

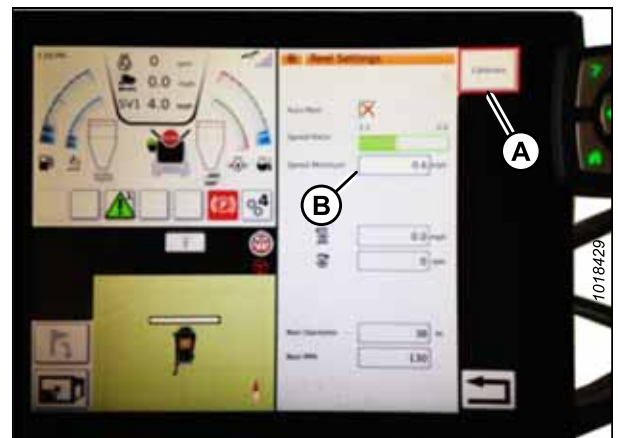


Figure 3.671: Reel Settings Calibration



Figure 3.672: Calibration Wizard

## AUTO HEADER HEIGHT CONTROL SYSTEM

5. A message appears in the CALIBRATION WIZARD stating that the reel calibration procedure has started. The reel will begin turning slowly and its speed will gradually increase. If necessary, select the red X (not shown) to cancel the calibration procedure. Otherwise, wait for the message that the reel calibration procedure has completed successfully. Select the green check mark to save the calibrated settings.



Figure 3.673: Calibration Progress

### 3.13.4 Setting up Automatic Header Controls – IDEAL™ Series

To configure the automatic header height control (AHHC) functions on an IDEAL™ Series combine to work with your header, navigate to the HEADER SETTINGS page on the combine's computer.

#### NOTE:

Changes may have been made to the combine controls or the display since this document was published. For the most up-to-date information, refer to the combine operator's manual.

1. **Automatic Control Functions:** There are toggle (OFF/ON) switches on the HEADER SETTINGS page for the automatic control functions. For MacDon headers, ensure that the following two functions are enabled as shown:

- RTC (return to cut) (A)
- AHHC (automatic header height control) (B)

All other switches should be disabled (not highlighted).

2. **Sensitivity** setting (C) controls how responsive a control (RTC or AHHC) is to a given change in sensor feedback. The setting fields are located directly below the toggle switches. To enter a new sensitivity setting, touch the setting field below the specific toggle switch, and enter the new value in the on-screen keyboard.

- Increase the sensitivity if the combine does not change the feeder position quickly enough when in Auto Mode.
- Decrease the sensitivity if the combine continually hunts for a position in Auto Mode.

#### NOTE:

The following sensitivity settings are recommended for MacDon headers:

- **50** for RTC (A)
- **60** for AHHC (B)

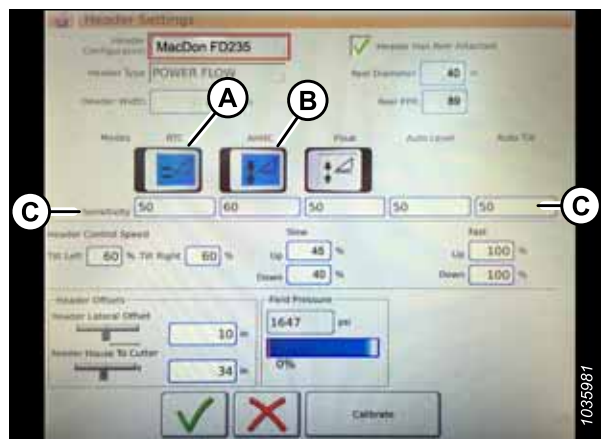


Figure 3.674: Automatic Controls and Sensitivity Settings

## AUTO HEADER HEIGHT CONTROL SYSTEM

3. **Header Speed:** HEADER CONTROL SPEED area (A) on the HEADER SETTINGS page is used to adjust the following speeds:

- Tilt left and right is the lateral tilt of the combine faceplate.
- The header raise/lower function uses a two-detent button: the first detent is a slow raise/lower rate; the second detent is a fast raise/lower rate.

**NOTE:**

The recommended header control speed settings are:

- Slow: Up 45/Down 40
- Fast: Up 100/Down 100

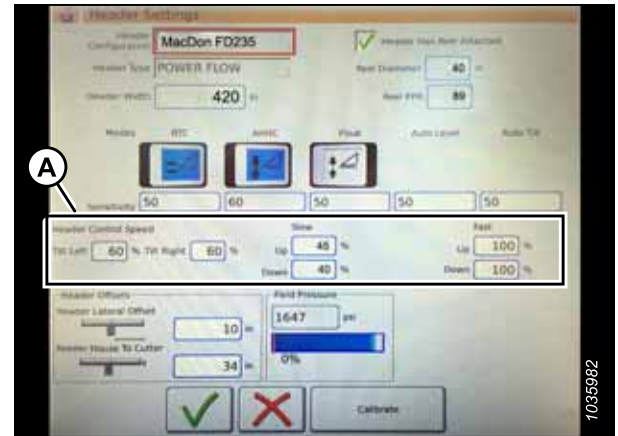


Figure 3.675: Header Speed Control Settings

4. **Header Offsets (A):** Offset distances are important for yield mapping. There are two adjustable dimensions on the HEADER SETTINGS page:

- **HEADER LATERAL OFFSET:** the distance between the centerline of the header and the centerline of the machine. This should be set at **0** for a MacDon header.
- **FEEDER HOUSE TO CUTTER:** the distance from the machine interface to the cutterbar. This should be set at **68** for a MacDon header.

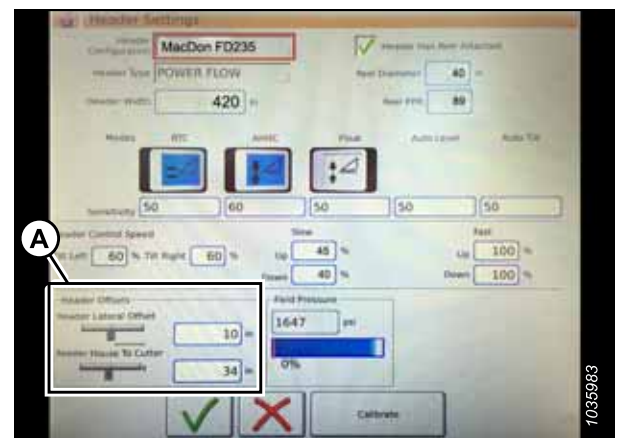


Figure 3.676: Header Offset Settings

### 3.13.5 Calibrating Header – IDEAL™ Series

The auto header height control (AHC) sensor output must be calibrated for the combine.

#### **DANGER**

To prevent bodily injury or death from the unexpected start-up of the machine, always stop the engine and remove the key from the ignition before making adjustments to the machine.

#### **DANGER**

Ensure that all bystanders have cleared the area.

**NOTE:**

Changes may have been made to the combine controls or the display since this document was published. For the most up-to-date information, refer to the combine operator's manual.

**NOTE:**

If the header float is set too light, it can prevent the calibration of the AHC. In order to prevent the header from separating from the float module, it may be necessary to change the float to a heavier setting during calibration.

## AUTO HEADER HEIGHT CONTROL SYSTEM

1. Park the combine on a level surface.
2. Ensure that the header is level with the ground. If adjustment is required:
  - Ensure that the combine is parked on a level surface.
  - If equipped, use the combine's lateral tilt to level the feeder house with the ground.
  - If further adjustment is required, shut the engine off, remove the key from the ignition, and ensure that the combine's tires are inflated to the correct pressure.

### NOTE:

Spirit level (A) is located on top of the float module frame. The header is level if the bubble is in the center of the spirit level.

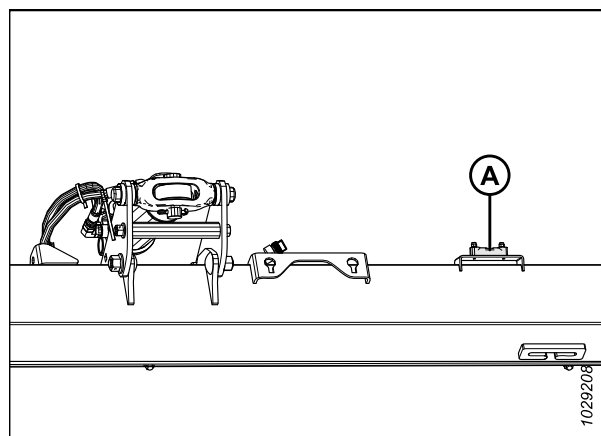


Figure 3.677: Spirit Level

3. Ensure that the center-link is set to **D**.

### NOTE:

When calibration is complete, adjust the center-link back to the desired header angle. For instructions, refer to [3.9.5 Header Angle, page 232](#).

4. Adjust the reel fore-aft position so that the indicator is at position **6**.
5. Position the header so that the cutterbar is 254–356 mm (10–14 in.) off the ground.
6. Shut down the engine, and remove the key from the ignition.

## AUTO HEADER HEIGHT CONTROL SYSTEM

### CAUTION

To prevent cuts, pinches, and other bodily harm to the person checking the down stops, ensure that nobody is manually lifting, bouncing, or moving the header in any way while the down stop washer is being touched and checked for movement.

7. Ensure that the float lock linkage is on the down stops (washer [A] cannot move) at both locations.

#### NOTE:

If the header is **NOT** on the down stops, the voltage may go out of range during operation and cause the AHHC system to malfunction. To fix the problem, make the header heavier by decreasing the float. For instructions, refer to [Checking and Adjusting Header Float, page 210](#).

8. Unlock the header float. For instructions, refer to [Locking / Unlocking Header Float, page 221](#).
9. Lock the header wings. For instructions, refer to [Operating in Rigid Mode, page 224](#).

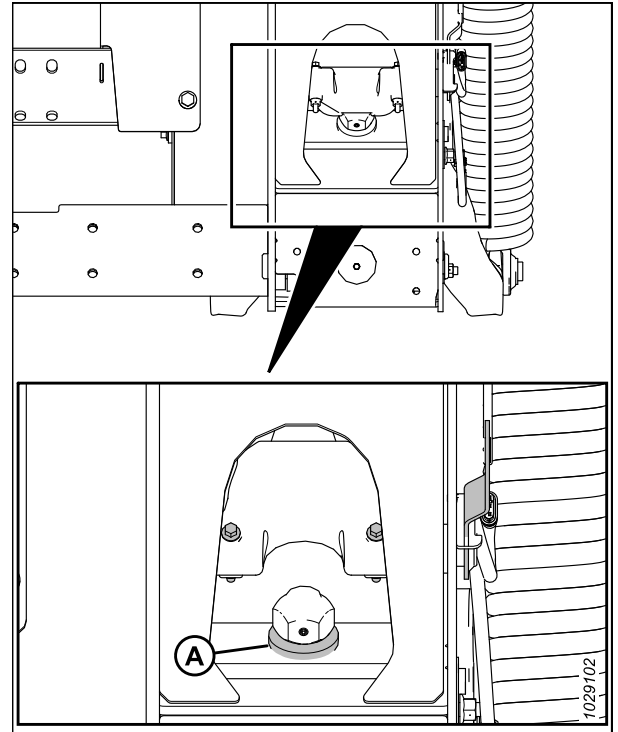


Figure 3.678: Down Stop Washer

10. On the COMBINE MAIN MENU, select HEADER SETTINGS icon (A).

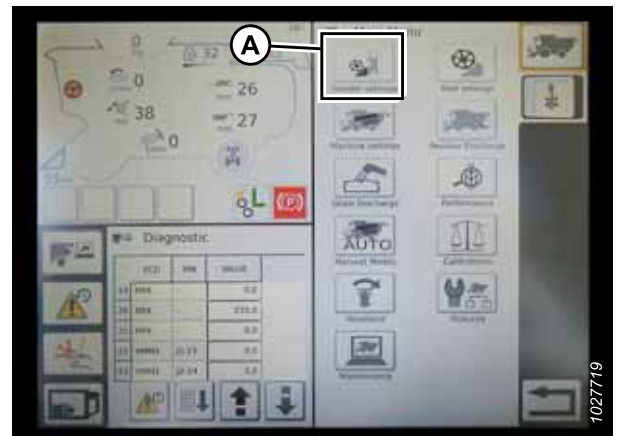


Figure 3.679: Combine Main Menu

## AUTO HEADER HEIGHT CONTROL SYSTEM

11. Select HEADER CALIBRATION icon (A) beside the HEADER SETTINGS CONFIG page.

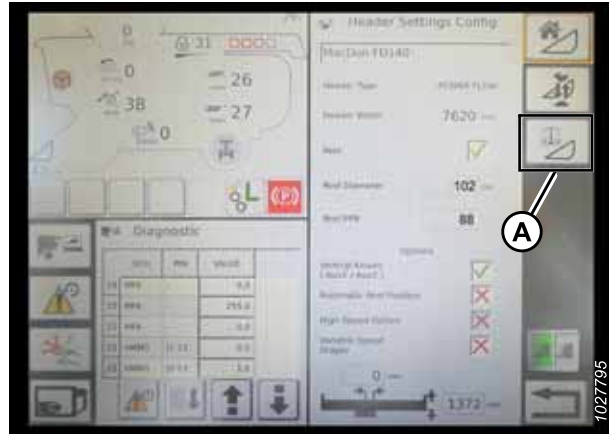


Figure 3.680: Header Settings Page

12. The hazard warning for HEADER CALIBRATION appears. Ensure that all conditions are met.
13. Select the green check mark at the bottom of the page to start the calibration procedure and follow the on-screen commands.



Figure 3.681: Header Calibration Warning

A progress bar is provided; the calibration process can be stopped by selecting the red X. The header moves automatically and erratically during this process.

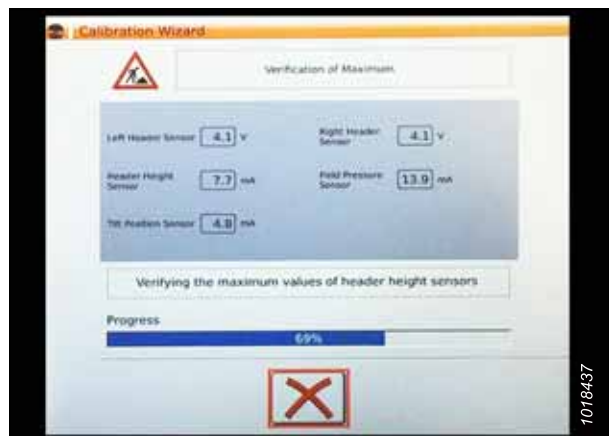


Figure 3.682: Calibration in Progress

## AUTO HEADER HEIGHT CONTROL SYSTEM

14. When the calibration procedure is complete:

- Review summary information (A)
- Ensure that green check marks confirm calibrated functions (B)
- Select check mark (C) to save the calibrated settings

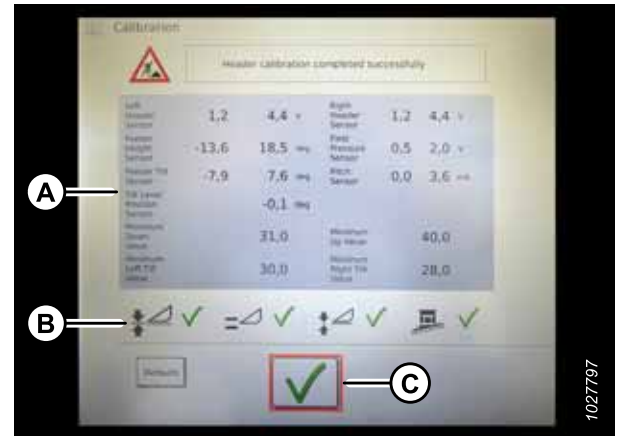


Figure 3.683: Completed Calibration Page

### NOTE:

Select CALIBRATIONS icon (A) on the MAIN MENU page to display the CALIBRATION MENU where you can choose from a variety of calibrations including header and reel calibration.

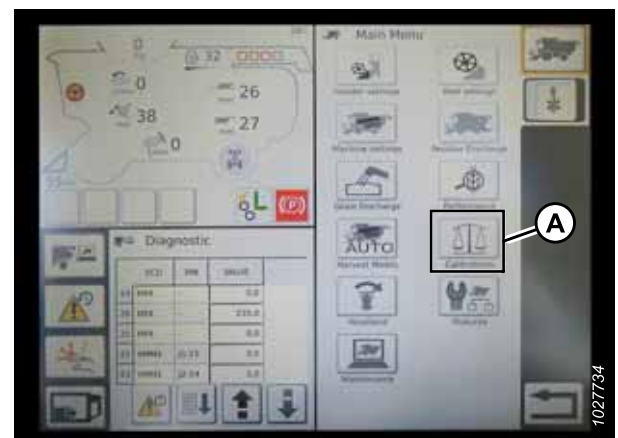


Figure 3.684: Direct Calibration Menu

### 3.13.6 Operating Header – IDEAL™ Series

Once the auto header height control (AHHC) system has been configured on your IDEAL™ Series combine, you can control the AHHC system from the combine cab.

### NOTE:

Changes may have been made to the combine controls or the display since this document was published. For the most up-to-date information, refer to the combine operator's manual.



## AUTO HEADER HEIGHT CONTROL SYSTEM

The following are used to operate the AHHC functions:

- Tyton terminal (A)
- Control handle (B)
- Throttle (C)
- Header control cluster (D)

Refer to the combine operator's manual to familiarize yourself with the combine's controls.



Figure 3.685: Operator's Station

1. With the header running, set the lateral tilt to MANUAL by pressing switch (A). The light above switch (A) should be off.
2. Engage the AHHC by pressing switch (B). The light above switch (B) should be on.



Figure 3.686: Header Control Cluster

3. Press AHHC control switch (A) on the control handle to engage the AHHC. The header moves to the configured set point position.



Figure 3.687: AHHC on Control Handle



## AUTO HEADER HEIGHT CONTROL SYSTEM

4. Use HEADER HEIGHT SETPOINT control dial (A) as necessary to fine-tune the header position.



Figure 3.688: Header Control Cluster

### 3.13.7 Reviewing Header In-Field Settings – IDEAL™ Series

Once the auto header height control (AHHC) system is working correctly with your IDEAL™ Series combine, you can fine-tune these AHHC settings to your liking.

#### NOTE:

Changes may have been made to the combine controls or the display since this document was published. For the most up-to-date information, refer to the combine operator's manual.

1. Select HEADER icon (A) on the right side of the home page to view the following header group settings:
  - CURRENT POSITION of header (B).
  - SETPOINT cut-off position (C) (indicated by the red line)
  - HEADER symbol (D) – select this to adjust the set point cut-off position using the adjustment wheel on the right side of the Tyton terminal.
  - CUT HEIGHT for AHHC (E) – fine-tune this setting with the header height set point control dial on the header control cluster.
  - HEADER WORKING WIDTH (F)
  - HEADER PITCH (G)

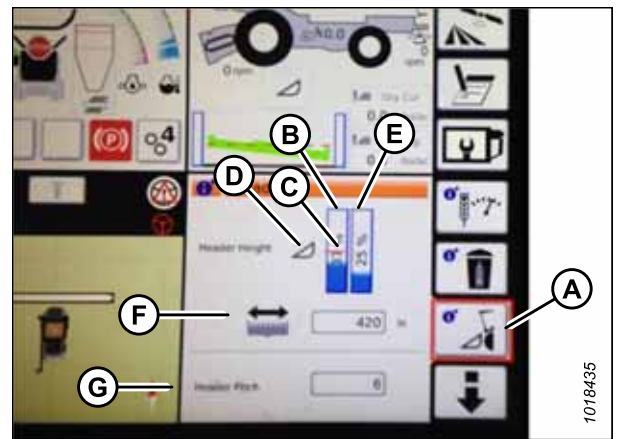


Figure 3.689: Header Groups

## AUTO HEADER HEIGHT CONTROL SYSTEM

2. Selecting a field opens the on-screen keyboard so that the values can be adjusted. Enter the new value and touch the green check mark.

**NOTE:**

Adjustment wheel (A) is located on the right of the Tyton terminal.

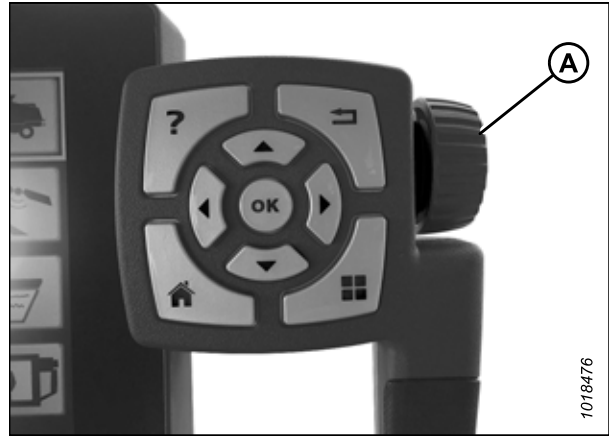


Figure 3.690: Adjustment Wheel on Right of Tyton Terminal

**NOTE:**

HEADER HEIGHT SETPOINT control dial (A) is on the header control cluster.



Figure 3.691: Header Control Cluster

## 3.14 John Deere 60 Series Combines

Follow these steps to set up auto header height control (AHHC) on John Deere 60 series combines.

### 3.14.1 Checking Voltage Range from Combine Cab – John Deere 60 Series

The auto header height control (AHHC) sensor needs to operate in a specific voltage range in order to work properly.

**NOTE:**

Changes may have been made to the combine controls or the display since this document was published. For the most up-to-date information, refer to the combine operator's manual.

**⚠ DANGER**

To prevent bodily injury or death from the unexpected start-up of the machine, always stop the engine and remove the key from the ignition before making adjustments to the machine.

**⚠ DANGER**

Ensure that all bystanders have cleared the area.

1. Position the header so that the cutterbar is 254–356 mm (10–14 in.) off the ground.
2. Shut down the engine, and remove the key from the ignition.
3. Unlock the header float. For instructions, refer to [Locking / Unlocking Header Float, page 221](#).
4. Lock the header wings. For instructions, refer to [Operating in Rigid Mode, page 224](#).

**⚠ CAUTION**

To prevent cuts, pinches, and other bodily harm to the person checking the down stops, ensure that nobody is manually lifting, bouncing, or moving the header in any way while the down stop washer is being touched and checked for movement.

5. Ensure that the float lock linkage is on the down stops (washer [A] cannot move) at both locations.

**NOTE:**

If the header is **NOT** on the down stops, the voltage may go out of range during operation and cause the AHHC system to malfunction. To fix the problem, make the header heavier by decreasing the float. For instructions, refer to [Checking and Adjusting Header Float, page 210](#).

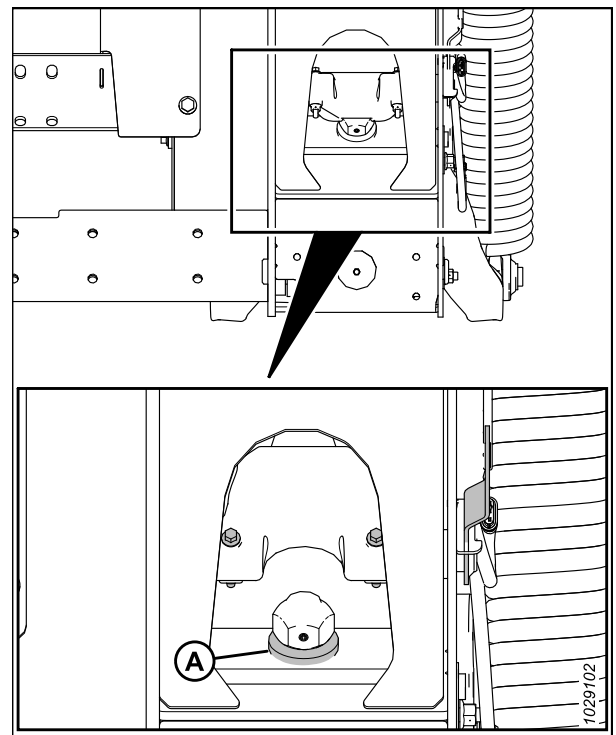


Figure 3.692: Down Stop Washer

## AUTO HEADER HEIGHT CONTROL SYSTEM

- If the pointer is not on zero, loosen bolt (A) and rotate float indicator plate (B) until pointer (C) is on 0 (D). Tighten the nut on bolt (A).

**NOTE:**

Use zero dot (E) above the decal to correctly set the indicator needle.

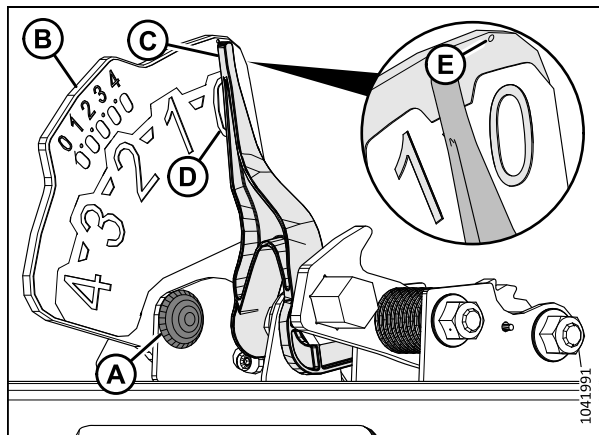


Figure 3.693: Float Indicator

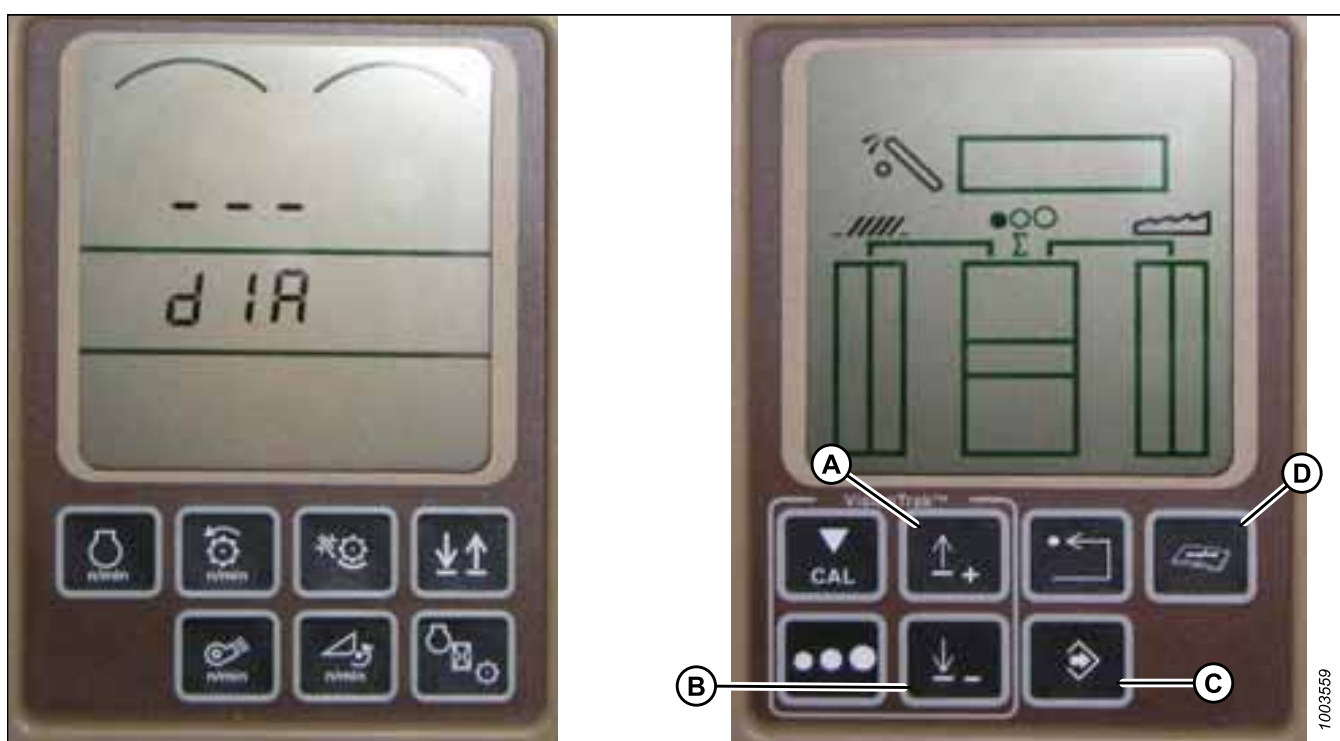


Figure 3.694: John Deere Combine Display

- Press DIAGNOSTIC button (D) on the display—DIA appears on the display.
- Press UP button (A) until EO1 appears on the display—this is the header adjustments.
- Press ENTER button (C).
- Press the UP (A) or DOWN button (B) until 24 is shown on the top portion of the display—this is the voltage reading for the sensor.
- Ensure the header float is unlocked.
- Start the combine, and fully lower the feeder house to the ground.

**NOTE:**

You may need to hold the HEADER DOWN switch for a few seconds to ensure the feeder house is fully lowered.

13. Check the sensor reading on the display. The reading should be above 0.5 V.
14. Raise the header so it is just off the ground. The reading on the display should read below 4.5 V.
15. If the sensor voltage is not within the lower and upper limits, or if the range between the lower and upper limits is insufficient, refer to [3.3 Manually Checking Voltage Limits, page 296](#).

### 3.14.2 Calibrating Auto Header Height Control – John Deere 60 Series

The auto header height control (AHHC) sensor output must be calibrated for each combine, or the AHHC feature will not work properly.

#### DANGER

To prevent bodily injury or death from the unexpected start-up of the machine, always stop the engine and remove the key from the ignition before making adjustments to the machine.

#### DANGER

Ensure that all bystanders have cleared the area.

#### NOTE:

Changes may have been made to the combine controls or the display since this document was published. For the most up-to-date information, refer to the combine operator's manual.

#### NOTE:

If the header float is set too light, it can prevent the calibration of the AHHC. In order to prevent the header from separating from the float module, it may be necessary to change the float to a heavier setting during calibration.

1. Park the combine on a level surface.
2. Ensure that the header is level with the ground. If adjustment is required:
  - Ensure that the combine is parked on a level surface.
  - If equipped, use the combine's lateral tilt to level the feeder house with the ground.
  - If further adjustment is required, shut the engine off, remove the key from the ignition, and ensure that the combine's tires are inflated to the correct pressure.

#### NOTE:

Spirit level (A) is located on top of the float module frame. The header is level if the bubble is in the center of the spirit level.

3. Ensure that the center-link is set to **D**.

#### NOTE:

When calibration is complete, adjust the center-link back to the desired header angle. For instructions, refer to [3.9.5 Header Angle, page 232](#).

4. Adjust the reel fore-aft position so that the indicator is at position **6**.

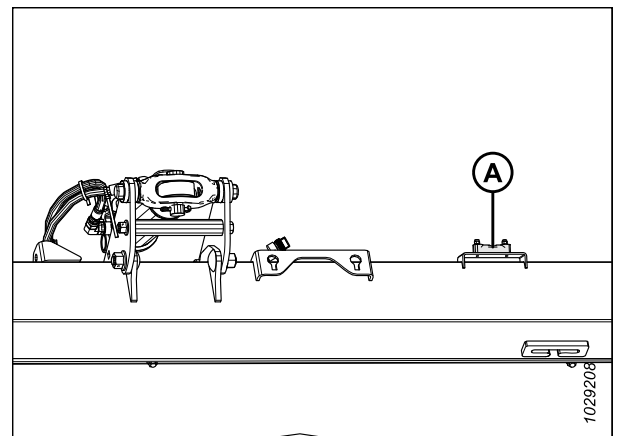


Figure 3.695: Spirit Level

## AUTO HEADER HEIGHT CONTROL SYSTEM

5. Position the header so that the cutterbar is 254–356 mm (10–14 in.) off the ground.
6. Shut down the engine, and remove the key from the ignition.

### CAUTION

To prevent cuts, pinches, and other bodily harm to the person checking the down stops, ensure that nobody is manually lifting, bouncing, or moving the header in any way while the down stop washer is being touched and checked for movement.

7. Ensure that the float lock linkage is on the down stops (washer [A] cannot move) at both locations.

#### NOTE:

If the header is **NOT** on the down stops, the voltage may go out of range during operation and cause the AHHC system to malfunction. To fix the problem, make the header heavier by decreasing the float. For instructions, refer to [Checking and Adjusting Header Float, page 210](#).

8. Unlock the header float. For instructions, refer to [Locking / Unlocking Header Float, page 221](#).
9. Lock the header wings. For instructions, refer to [Operating in Rigid Mode, page 224](#).

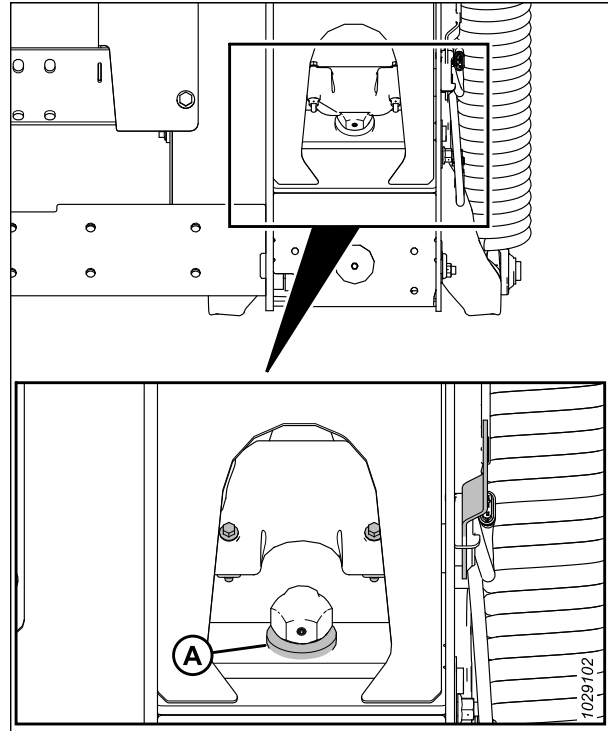


Figure 3.696: Down Stop Washer

## AUTO HEADER HEIGHT CONTROL SYSTEM

10. Press DIAGNOSTIC button (A) on the display. DIA appears on the display.
11. Press CAL button (B). DIA-CAL appears on the display.

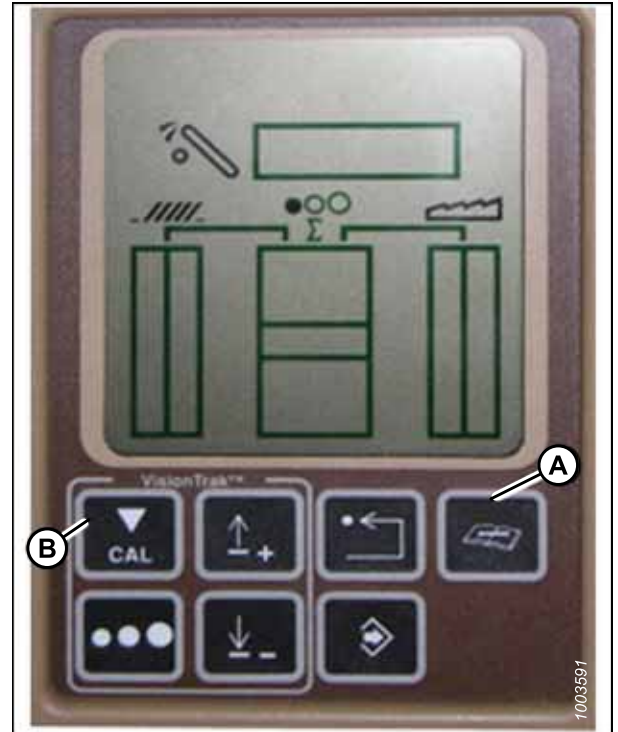


Figure 3.697: John Deere Combine Display

12. Press the UP or DOWN buttons until HDR appears on the display.
13. Press the ENTER button. HDR H-DN appears on the display.
14. Fully lower the feeder house to the ground.

**NOTE:**

You may need to hold the HEADER DOWN switch for a few seconds to ensure the feeder house is fully lowered.

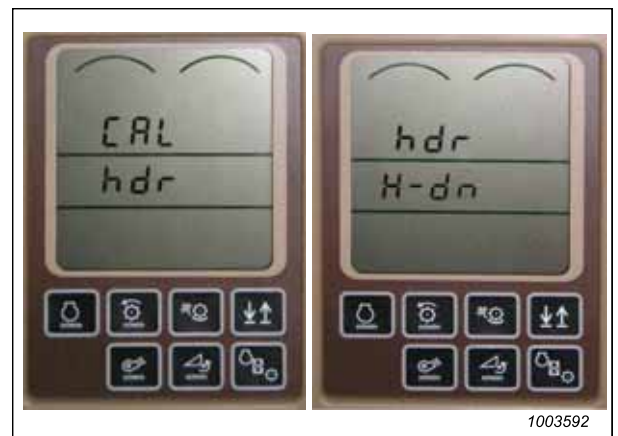


Figure 3.698: John Deere Combine Display



## AUTO HEADER HEIGHT CONTROL SYSTEM

15. Press CAL button (A) to save the calibration of the header. HDR H-UP appears on the display.
16. Raise the header 1 m (3 ft.) off the ground and press CAL button (A). EOC appears on the display.
17. Press ENTER button (B) to save the calibration of the header. The AHHC is now calibrated.

### NOTE:

If an error code appears during calibration, the sensor is out of voltage range and will require adjustment. For instructions, refer to [3.14.1 Checking Voltage Range from Combine Cab – John Deere 60 Series, page 431](#).

### NOTE:

After the calibration is complete, adjust the combine operation settings to ensure proper field operation.

### NOTE:

If the float was set heavier to complete the AHHC calibration procedure, adjust it to the recommended operating float after the calibration is complete.

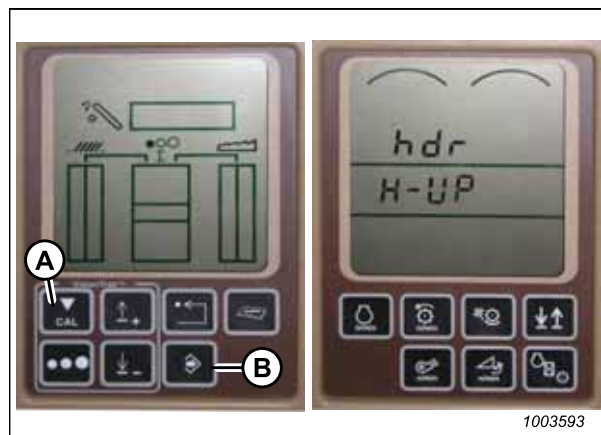


Figure 3.699: John Deere Combine Display

### 3.14.3 Turning Accumulator Off – John Deere 60 Series

The accumulator prevents shocks to the hydraulic system when the combine is operating with a heavy header attached. The accumulator should not be used when operating the combine with a header that has a float module attached.

## DANGER

Ensure that all bystanders have cleared the area.

### NOTE:

Changes may have been made to the combine controls or the display since this document was published. For the most up-to-date information, refer to the combine operator's manual.

1. Press DIAGNOSTIC button (A) on the display. DIA appears on the display.
2. Press UP button (B) until EO1 appears on the display, and press ENTER (D). This is the header adjustment.
3. Press UP (B) or DOWN (C) button until 132 is displayed on the top portion of the display. This is the reading for the accumulator.
4. Press ENTER (D) to select 132 as the accumulator reading (this will allow you to change the display to a three-digit number so it has a 0 in it, for example, x0x).
5. Press UP (B) or DOWN (C) button until the desired number is displayed, and press CAL button (E).
6. Press ENTER (D) to save the changes. The accumulator is now deactivated.

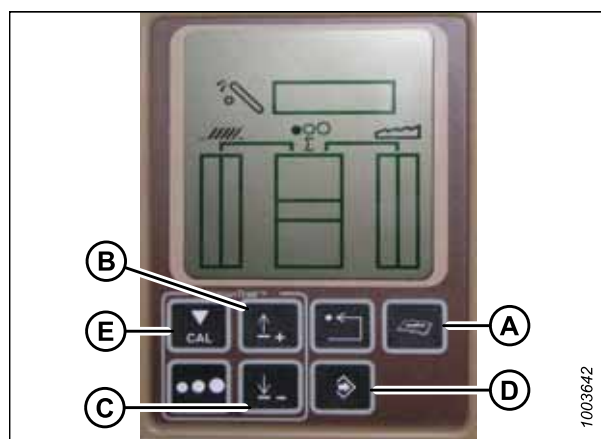


Figure 3.700: John Deere Combine Display



### 3.14.4 Setting Header Height Sensitivity – John Deere 60 Series

In order for a John Deere 60 Series combine to accurately read the output from the height sensors on a MacDon header, the combine's sensitivity setting needs to be set to 50.

#### DANGER

Ensure that all bystanders have cleared the area.

#### NOTE:

Changes may have been made to the combine controls or the display since this document was published. For the most up-to-date information, refer to the combine operator's manual.

1. Press DIAGNOSTIC button (A) on the display. DIA appears on the display.
2. Press UP button (B) until EO1 appears on the display, and press ENTER (D). This is the header adjustment.
3. Press UP (B) or DOWN (C) button until 128 is shown on the top portion of the display. This is the reading for the sensor.
4. Press ENTER (D) to select 128 as the sensor reading (this will allow you to change the display to a three-digit number so it has a 50 in it).
5. Press UP (B) or DOWN (C) button until the desired number is displayed, and press CAL button (E).
6. Press ENTER (D) to save the changes. The height is now set.

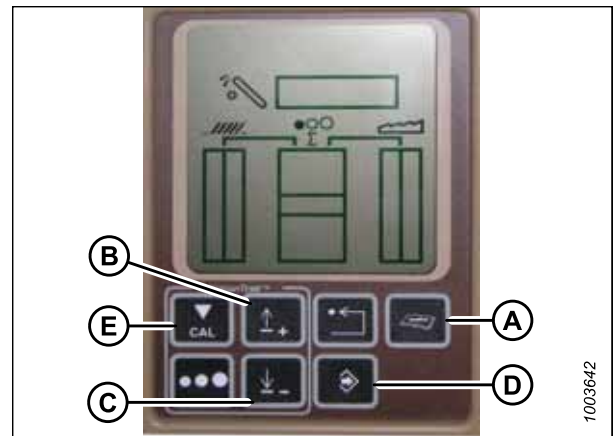


Figure 3.701: John Deere Combine Display

#### NOTE:

Do **NOT** use active header float function (A) in combination with the MacDon auto header height control (AHHC)—the two systems will counteract one another. Header symbol (B) on the display should **NOT** have a wavy line under it and should appear exactly as shown on the Active Header Control Display in Figure 3.702, page 437.

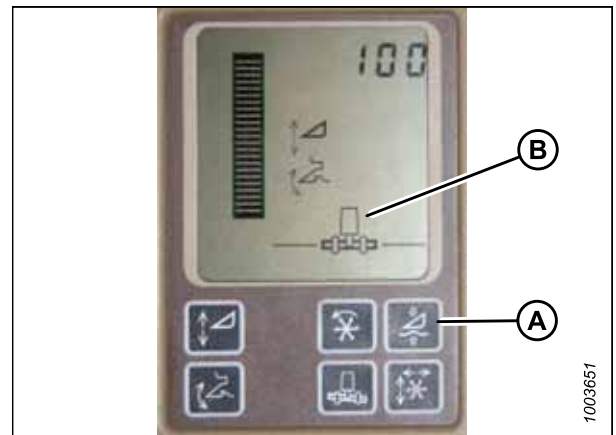


Figure 3.702: John Deere Combine Display

### 3.14.5 Setting Auto Header Height Control Sensitivity – John Deere 60 Series

The sensitivity adjustment controls the distance the cutterbar must travel up or down before the auto header height control (AHHC) reacts and raises or lowers the feeder house.

#### DANGER

Ensure that all bystanders have cleared the area.

## AUTO HEADER HEIGHT CONTROL SYSTEM

When the sensitivity is set to maximum, only small changes in ground height are needed to cause the feeder house to raise or lower. When the sensitivity is set to minimum, large changes in the ground height are needed to cause the feeder house to raise or lower.

### NOTE:

Changes may have been made to the combine controls or the display since this document was published. For the most up-to-date information, refer to the combine operator's manual.

### NOTE:

The numbers shown on the displays in these illustrations are for reference purposes only; they are not intended to represent the specific settings for your equipment.

1. Press DIAGNOSTIC button (A) on the display. DIA appears on the display.
2. Press UP button (B) until EO1 appears on the display, and press ENTER (D). This is the header adjustment.
3. Press UP (B) or DOWN (C) button until 112 is shown on the display. This is your sensitivity setting.

### NOTE:

The lower the reading, the higher the sensitivity. Ideal operating range is typically between 50 and 80.

4. Press ENTER (D) to select 112 as the sensitivity setting (this will allow you to change the first digit of the number sequence).
5. Press UP (B) or DOWN (C) until the desired number is displayed, then press CAL button (E). This will bring you to the second digit. Repeat this procedure until the desired setting is achieved.
6. Press ENTER (D) to save changes.

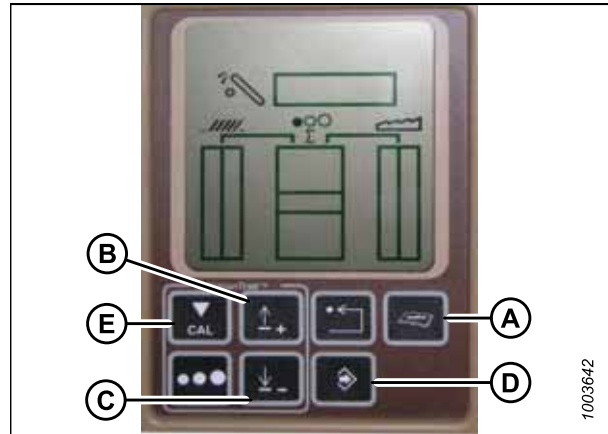


Figure 3.703: John Deere Combine Display

### 3.14.6 Adjusting Drop Rate Valve Threshold – John Deere 60 Series

This procedure details how to adjust the point at which the restrictor valve opens to allow full flow to the lift cylinders.

### DANGER

Ensure that all bystanders have cleared the area.

### NOTE:

Changes may have been made to the combine controls or the display since this document was published. For the most up-to-date information, refer to the combine operator's manual.

### NOTE:

The numbers shown on the displays in these illustrations are for reference purposes only; they are not intended to represent the specific settings for your equipment.

## AUTO HEADER HEIGHT CONTROL SYSTEM

1. Press DIAGNOSTIC button (A) on the display. DIA appears on the display.
2. Press UP button (B) until EO1 appears on the display and press ENTER (C). This is the header adjustment.
3. Press UP (B) or DOWN button until 114 is shown on the top portion of the display. This is the setting that adjusts when the fast drop rate starts with respect to the dead band.

**NOTE:**

The default setting is 100. The ideal operating range is typically between 60 and 85.

4. Press ENTER (C) to select 114 as the fast drop rate (this will allow you to change the first digit of the number sequence).
5. Press UP (A) or DOWN (B) until the desired number is displayed, then press CAL button (C). This will bring you to the second digit. Repeat this procedure until the desired setting is achieved.
6. Press ENTER (D) to save changes.

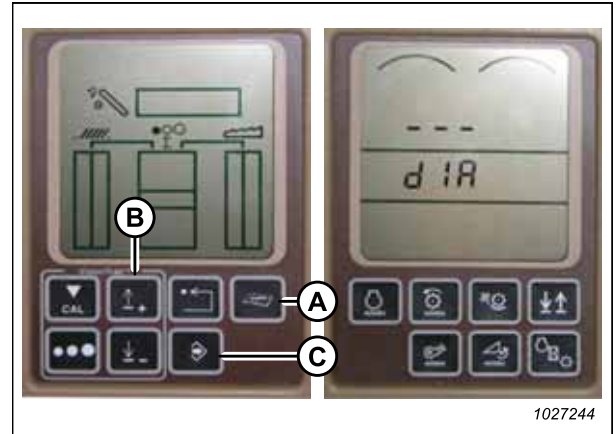


Figure 3.704: John Deere Combine Display

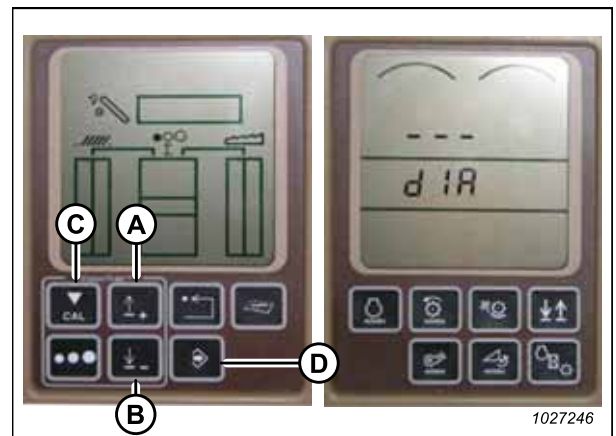


Figure 3.705: John Deere Combine Display

## 3.15 John Deere 70 Series Combines

To make your header's auto header height control (AHHC) system compatible with the combine, you must set your combine's header configuration options for the particular model of header, configure the reel speed settings, set up the AHHC controls, and calibrate the AHHC system to ensure that it is working correctly.

### 3.15.1 Checking Voltage Range from Combine Cab – John Deere 70 Series

The auto header height control (AHHC) sensor needs to operate in a specific voltage range in order to work properly.

**NOTE:**

Changes may have been made to the combine controls or the display since this document was published. For the most up-to-date information, refer to the combine operator's manual.

**! DANGER**

To prevent bodily injury or death from the unexpected start-up of the machine, always stop the engine and remove the key from the ignition before making adjustments to the machine.

**! DANGER**

Ensure that all bystanders have cleared the area.

1. Position the header so that the cutterbar is 254–356 mm (10–14 in.) off the ground.
2. Shut down the engine, and remove the key from the ignition.
3. Unlock the header float. For instructions, refer to [Locking / Unlocking Header Float, page 221](#).
4. Lock the header wings. For instructions, refer to [Operating in Rigid Mode, page 224](#).

**! CAUTION**

To prevent cuts, pinches, and other bodily harm to the person checking the down stops, ensure that nobody is manually lifting, bouncing, or moving the header in any way while the down stop washer is being touched and checked for movement.

5. Ensure that the float lock linkage is on the down stops (washer [A] cannot move) at both locations.

**NOTE:**

If the header is **NOT** on the down stops, the voltage may go out of range during operation and cause the AHHC system to malfunction. To fix the problem, make the header heavier by decreasing the float. For instructions, refer to [Checking and Adjusting Header Float, page 210](#).

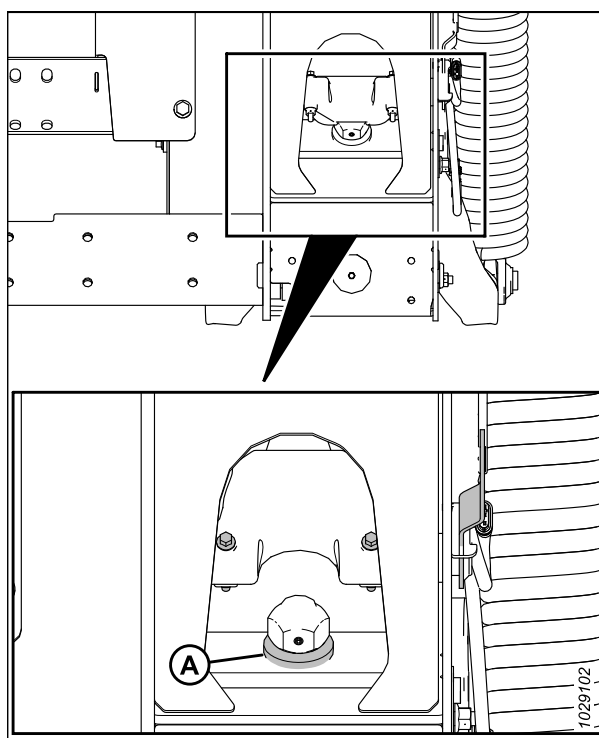


Figure 3.706: Down Stop Washer

## AUTO HEADER HEIGHT CONTROL SYSTEM

- If the pointer is not on zero, loosen bolt (A) and rotate float indicator plate (B) until pointer (C) is on 0 (D). Tighten the nut on bolt (A).

**NOTE:**

Use zero dot (E) above the decal to correctly set the indicator needle.

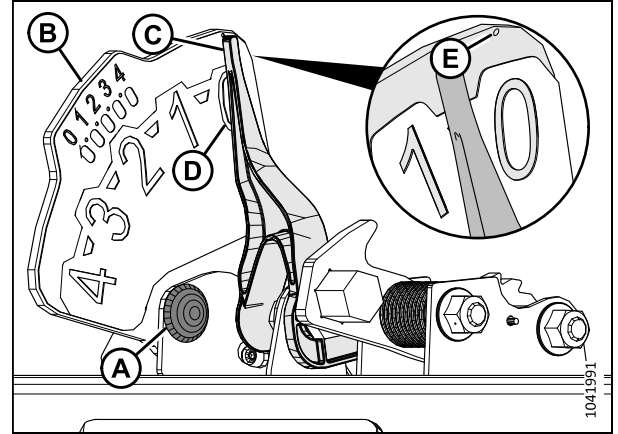


Figure 3.707: Float Indicator

- Press HOME PAGE button (A) on the main page of the display.



Figure 3.708: John Deere Combine Display

- Ensure that three icons (A) appear on the display.



Figure 3.709: John Deere Combine Display

## AUTO HEADER HEIGHT CONTROL SYSTEM

- Use scroll knob (A) to highlight the middle icon (the green i) and press check mark button (B) to select it. The MESSAGE CENTER appears.

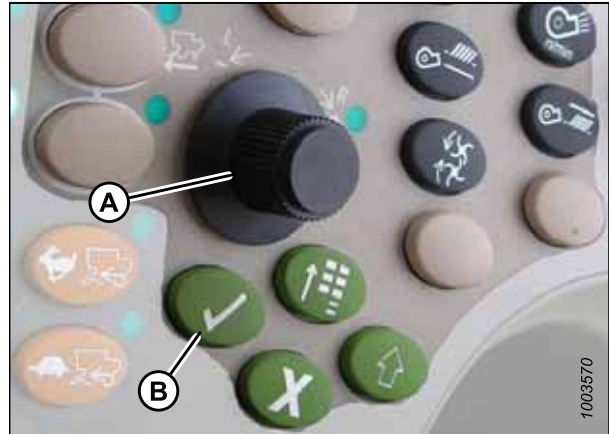


Figure 3.710: John Deere Combine Control Console

- Use the scroll knob to highlight DIAGNOSTIC ADDRESSES (A) from the right column. Select it by pressing the check mark button.
- Use the scroll knob to highlight drop-down box (B). Press the check mark button to select it.

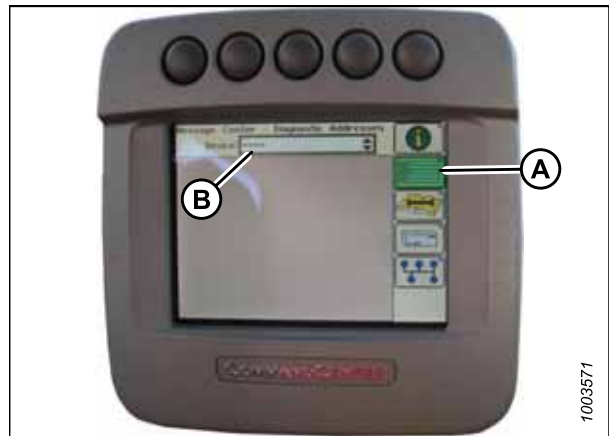


Figure 3.711: John Deere Combine Display

- Use the scroll knob to highlight LC 1.001 VEHICLE (A). Press the check mark button to select it.



Figure 3.712: John Deere Combine Display

## AUTO HEADER HEIGHT CONTROL SYSTEM

- Use the scroll knob to highlight down arrow (A). Press the check mark button to scroll through the list until 029 DATA (B) appears and voltage reading (C) appears on the display.
- Ensure that the header float is unlocked.
- Start the engine.

**NOTE:**

You may need to hold the HEADER DOWN switch for a few seconds to ensure that the feeder house is fully lowered.

- Fully lower the feeder house to the ground.

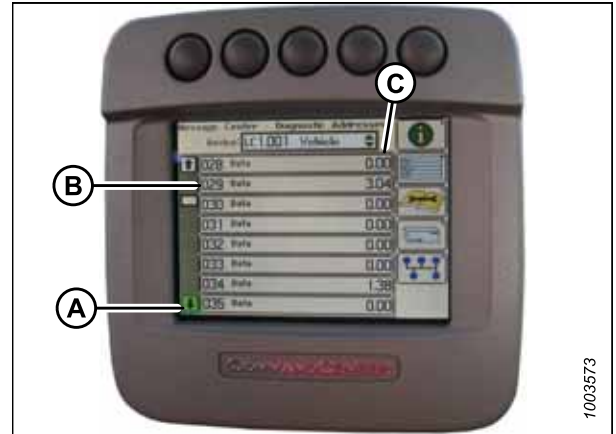


Figure 3.713: John Deere Combine Display

- Check the voltage reading on the display. For information on the appropriate voltage range, refer to [3.2 Recommended Sensor Output Voltages for Combines, page 295](#).
- Raise the header so that it is just off the ground and recheck the sensor reading.
- If the sensor voltage is not within the lower and upper limits, or if the range between the lower and upper limits is insufficient, refer to [3.3 Manually Checking Voltage Limits, page 296](#).

### 3.15.2 Calibrating Feeder House Speed – John Deere 70 Series

The feeder house speed must be calibrated before calibrating the auto header height control (AHHC) system. For instructions, refer to the combine operator's manual.

### 3.15.3 Adjusting Manual Header Raise/Lower Rate – John Deere 70 Series

The rate at which the header can be raised or lowered using the controls in the combine cab can be adjusted using the combine console.

**NOTE:**

Changes may have been made to the combine controls or the display since this document was published. For the most up-to-date information, refer to the combine operator's manual.

- Press button (A) and the current raise/lower rate setting will appear on the display (the lower the reading, the slower the speed at which the header moves).
- Use scroll knob (B) to adjust the rate. The adjustment will be saved automatically.

**NOTE:**

If the display remains idle for a short period of time, it will automatically return to the previous page. Pressing check mark button (C) will also return the display to the previous page.

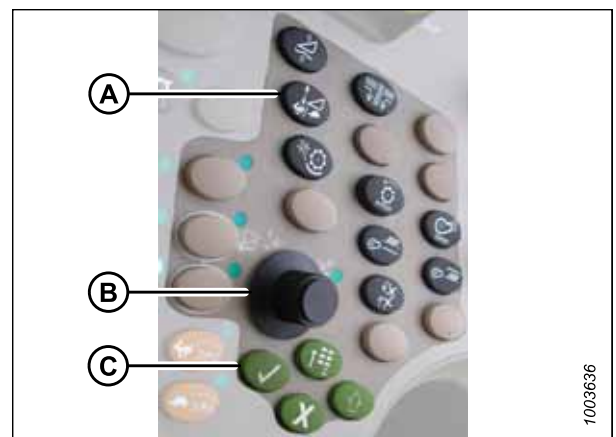


Figure 3.714: John Deere Combine Control Console



## AUTO HEADER HEIGHT CONTROL SYSTEM

### NOTE:

The numbers shown on the displays in these illustrations are for reference purposes only; they are not intended to represent the specific settings for your equipment.



Figure 3.715: John Deere Combine Display

### 3.15.4 Calibrating Auto Header Height Control – John Deere 70 Series

The auto header height control (AHHC) sensor output must be calibrated for each combine.

#### DANGER

To prevent bodily injury or death from the unexpected start-up of the machine, always stop the engine and remove the key from the ignition before making adjustments to the machine.

#### DANGER

Ensure that all bystanders have cleared the area.

### NOTE:

Changes may have been made to the combine controls or the display since this document was published. For the most up-to-date information, refer to the combine operator's manual.

### NOTE:

If the header float is set too light, it can prevent the calibration of the AHHC. In order to prevent the header from separating from the float module, it may be necessary to change the float to a heavier setting during calibration.

1. Park the combine on a level surface.
2. Ensure that the header is level with the ground. If adjustment is required:
  - Ensure that the combine is parked on a level surface.
  - If equipped, use the combine's lateral tilt to level the feeder house with the ground.
  - If further adjustment is required, shut the engine off, remove the key from the ignition, and ensure that the combine's tires are inflated to the correct pressure.

### NOTE:

Spirit level (A) is located on top of the float module frame. The header is level if the bubble is in the center of the spirit level.

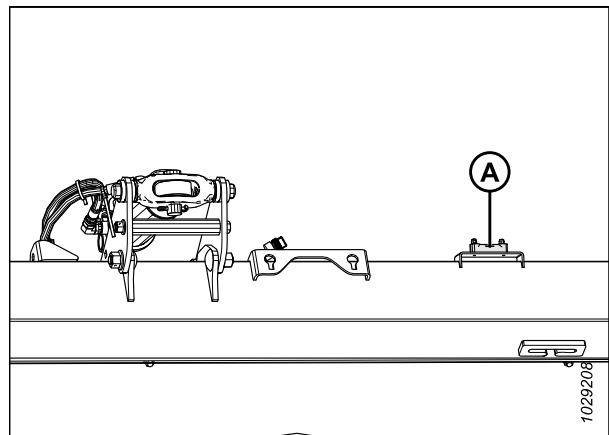


Figure 3.716: Spirit Level



## AUTO HEADER HEIGHT CONTROL SYSTEM

3. Ensure that the center-link is set to **D**.

### NOTE:

When calibration is complete, adjust the center-link back to the desired header angle. For instructions, refer to [3.9.5 Header Angle, page 232](#).

4. Adjust the reel fore-aft position so that the indicator is at position **6**.
5. Position the header so that the cutterbar is 254–356 mm (10–14 in.) off the ground.
6. Shut down the engine, and remove the key from the ignition.



### CAUTION

To prevent cuts, pinches, and other bodily harm to the person checking the down stops, ensure that nobody is manually lifting, bouncing, or moving the header in any way while the down stop washer is being touched and checked for movement.

7. Ensure that the float lock linkage is on the down stops (washer [A] cannot move) at both locations.

### NOTE:

If the header is **NOT** on the down stops, the voltage may go out of range during operation and cause the AHHC system to malfunction. To fix the problem, make the header heavier by decreasing the float. For instructions, refer to [Checking and Adjusting Header Float, page 210](#).

8. Unlock the header float. For instructions, refer to [Locking / Unlocking Header Float, page 221](#).
9. Lock the header wings. For instructions, refer to [Operating in Rigid Mode, page 224](#).

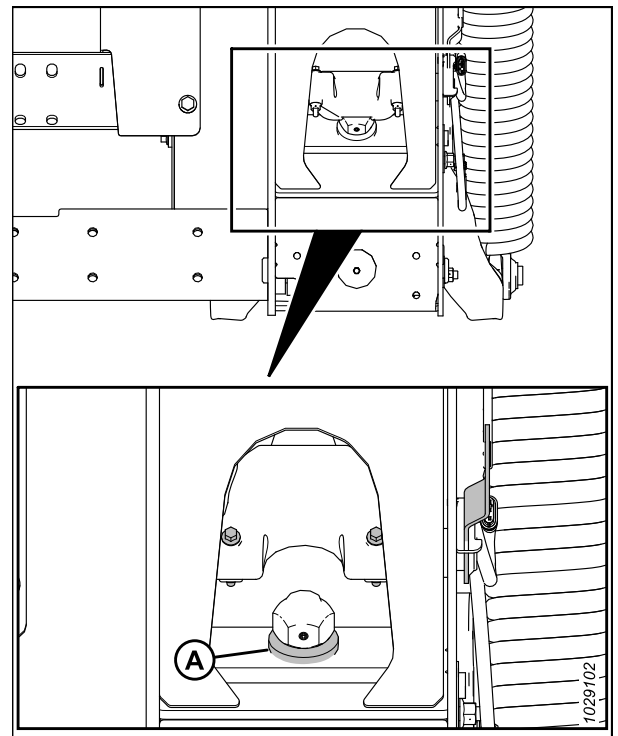


Figure 3.717: Down Stop Washer

## AUTO HEADER HEIGHT CONTROL SYSTEM

10. Press button (A) to select icon (B).
11. Press button (A) a second time to enter diagnostics and calibration mode.

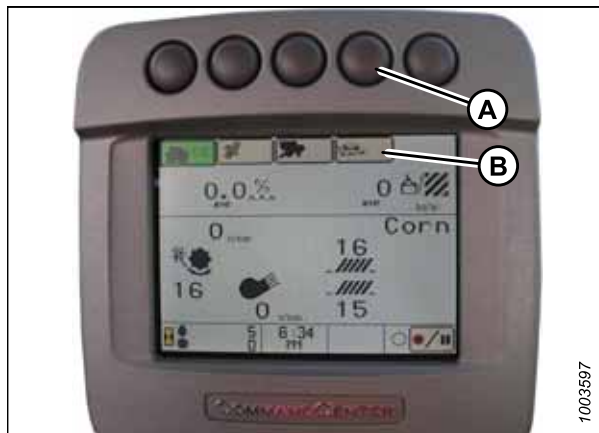


Figure 3.718: John Deere Combine Display

12. Select HEADER in box (A) by scrolling down to the box using the scroll knob, then pressing the check mark button.

**NOTE:**

The knob and button are shown in Figure 3.720, page 446.

13. Scroll down to lower right icon (B) and press the check mark button to select it.
14. Follow the steps listed on the page to perform the calibration.

**NOTE:**

If an error code appears on the display, the sensor is not in the correct working range. Check and adjust the range. For instructions, refer to [3.16.1 Checking Voltage Range from Combine Cab – John Deere S and T Series, page 448](#).

15. If the float was set heavier to complete the AHHC calibration procedure, adjust it to the recommended operating float after the calibration is complete.

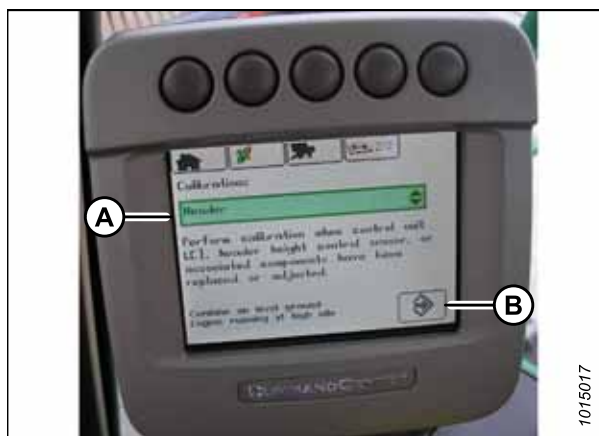


Figure 3.719: John Deere Combine Display

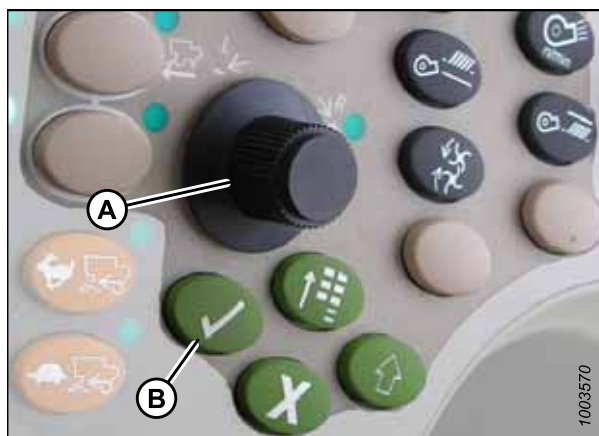


Figure 3.720: John Deere Combine Control Console

A - Scroll Knob

B - Check Mark Button

### 3.15.5 Setting Auto Header Height Control Sensitivity – John Deere 70 Series

The sensitivity adjustment controls the distance the cutterbar must travel up or down before the auto header height control (AHHC) reacts and raises or lowers the feeder house.

When the sensitivity is set to maximum, only small changes in ground height are needed to cause the feeder house to raise or lower. When the sensitivity is set to minimum, large changes in the ground height are needed to cause the feeder house to raise or lower.

**NOTE:**

Changes may have been made to the combine controls or the display since this document was published. For the most up-to-date information, refer to the combine operator’s manual.

1. Press button (A) twice. The current sensitivity setting will appear on the display.
2. Use scroll knob (B) to adjust the sensitivity setting. The adjustment will be saved automatically.

**NOTE:**

If the page remains idle for a short period of time, it will automatically return to the previous page. Pressing green check mark button (C) also will return the display to the previous page.

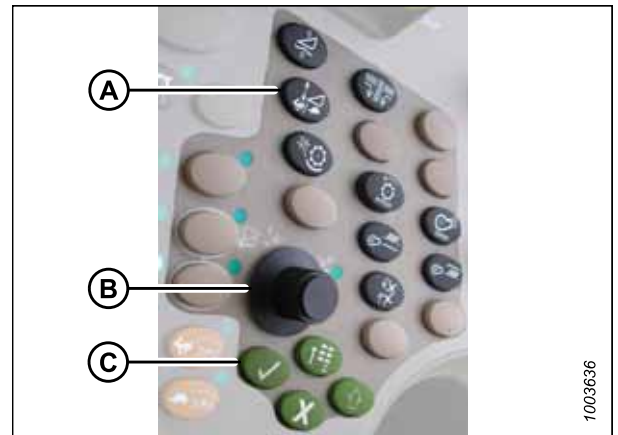


Figure 3.721: John Deere Combine Control Console

**NOTE:**

The numbers shown on the displays in these illustrations are for reference purposes only; they are not intended to represent the specific settings for your equipment.



Figure 3.722: John Deere Combine Display

### 3.16 John Deere S and T Series Combines

To make your header’s auto header height control (AHHC) system compatible with the combine, you must set your combine’s header configuration options for the particular model of header, configure the reel speed settings, set up the AHHC controls, and calibrate the AHHC system to ensure that it is working correctly.

#### 3.16.1 Checking Voltage Range from Combine Cab – John Deere S and T Series

The auto header height control (AHHC) sensor needs to operate in a specific voltage range in order to work properly.

**NOTE:**

Changes may have been made to the combine controls or the display since this document was published. For the most up-to-date information, refer to the combine operator’s manual.

**⚠ DANGER**

To prevent bodily injury or death from the unexpected start-up of the machine, always stop the engine and remove the key from the ignition before making adjustments to the machine.

**⚠ DANGER**

Ensure that all bystanders have cleared the area.

1. Position the header so that the cutterbar is 254–356 mm (10–14 in.) off the ground.
2. Shut down the engine, and remove the key from the ignition.
3. Unlock the header float. For instructions, refer to *Locking / Unlocking Header Float, page 221*.
4. Lock the header wings. For instructions, refer to *Operating in Rigid Mode, page 224*.

**⚠ CAUTION**

To prevent cuts, pinches, and other bodily harm to the person checking the down stops, ensure that nobody is manually lifting, bouncing, or moving the header in any way while the down stop washer is being touched and checked for movement.

5. Ensure that the float lock linkage is on the down stops (washer [A] cannot move) at both locations.

**NOTE:**

If the header is **NOT** on the down stops, the voltage may go out of range during operation and cause the AHHC system to malfunction. To fix the problem, make the header heavier by decreasing the float. For instructions, refer to *Checking and Adjusting Header Float, page 210*.

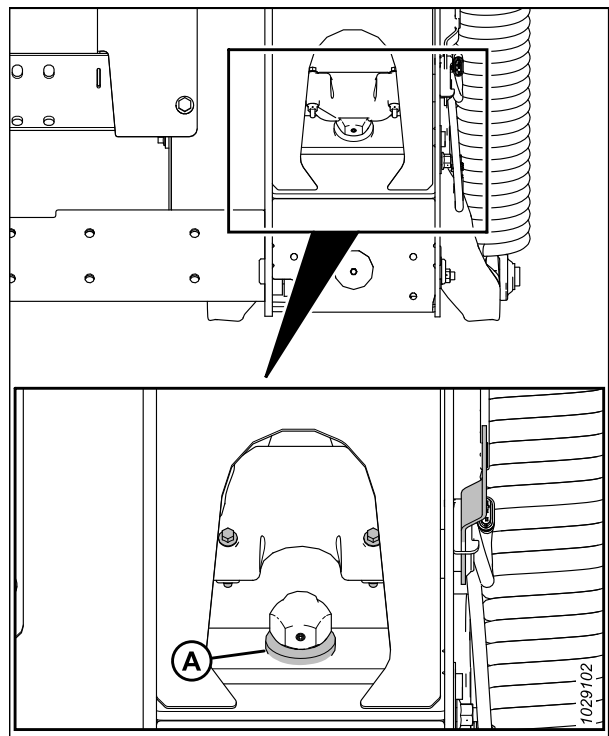


Figure 3.723: Down Stop Washer

## AUTO HEADER HEIGHT CONTROL SYSTEM

- If the pointer is not on zero, loosen bolt (A) and rotate float indicator plate (B) until pointer (C) is on 0 (D). Tighten the nut on bolt (A).

**NOTE:**

Use zero dot (E) above the decal to correctly set the indicator needle.

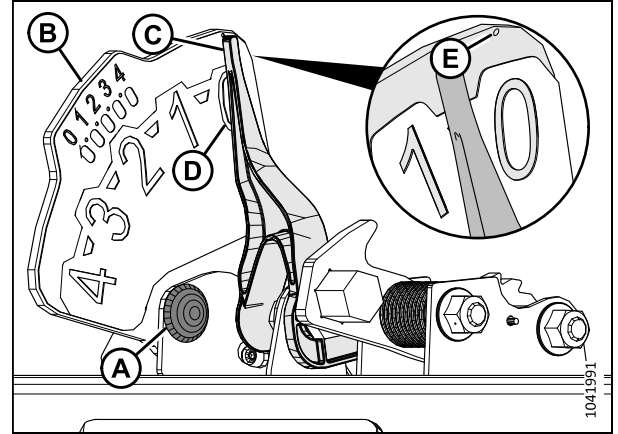


Figure 3.724: Float Indicator

- Select CALIBRATION icon (A) on the main page of the display. The CALIBRATION page appears.



Figure 3.725: John Deere Combine Display

- Select DIAGNOSTIC READINGS icon (A) on the CALIBRATION page. The DIAGNOSTIC READINGS page appears. This page provides access to calibrations, header options, and diagnostic information.

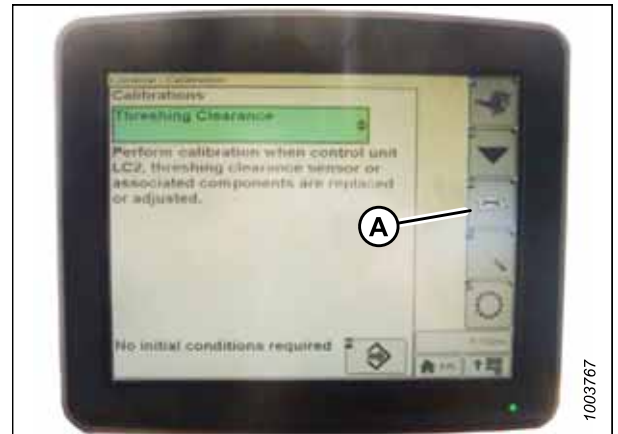


Figure 3.726: John Deere Combine Display

## AUTO HEADER HEIGHT CONTROL SYSTEM

9. Select AHHC RESUME (A) and a list of calibration options appears.



Figure 3.727: John Deere Combine Display

10. Select the AHHC SENSING option.
11. Press icon (A). The AHHC SENSING menu appears and five pages of information appear.



Figure 3.728: John Deere Combine Display

12. Press icon (A) until it reads Page 5 near the top of the page and the following sensor readings appear:

- LEFT HEADER HEIGHT
- CENTER HEADER HEIGHT
- RIGHT HEADER HEIGHT

A reading is displayed for both the left and right sensors.



Figure 3.729: John Deere Combine Display

13. Ensure that the header float is unlocked.
14. Start the engine.

## AUTO HEADER HEIGHT CONTROL SYSTEM

15. Fully lower the feeder house to the ground.

**NOTE:**

You may need to hold the HEADER DOWN switch for a few seconds to fully lower the feeder house.

16. Check the voltage reading on the display. For information on the appropriate voltage range, refer to [3.2 Recommended Sensor Output Voltages for Combines, page 295](#).
17. If the sensor voltage is not within the lower and upper limits, or if the range between the lower and upper limits is insufficient, refer to [3.3 Manually Checking Voltage Limits, page 296](#).

### 3.16.2 Adjusting Manual Header Raise/Lower Rate – John Deere S and T Series

The rate at which the header can be raised or lowered using the combine controls can be changed from the height sensitivity screen in the combine CommandCenter™.

**NOTE:**

Changes may have been made to the combine controls or the display since this document was published. For the most up-to-date information, refer to the combine operator's manual.

1. Put the wings in the locked position.

**NOTE:**

Indicator (A) should be at position 0 (B) with the header 254–356 mm (10–14 in.) off the ground. When the header is on the ground, the indicator should be at position 1 (C) for low ground pressure, and at position 4 (D) for high ground pressure. The crop and soil conditions determine the amount of float to use. The ideal setting is as light as possible without the header bouncing or missing crop. Operating with heavy settings prematurely wears the cutterbar wearplates.

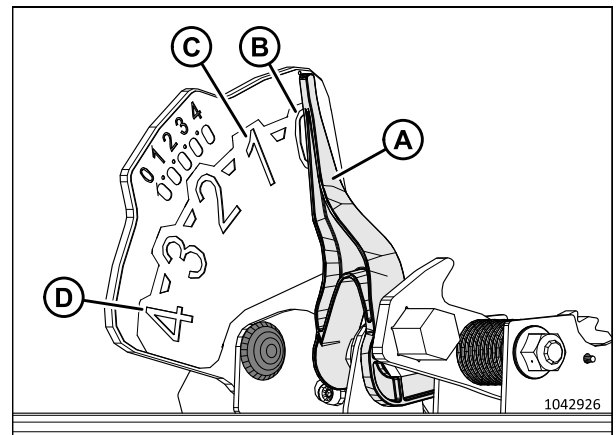


Figure 3.730: Float Indicator

2. Press button (A). The current sensitivity setting will appear on the display.



Figure 3.731: John Deere Combine CommandCenter™



## AUTO HEADER HEIGHT CONTROL SYSTEM

3. Press – or + icons (A) to adjust the rate.

### NOTE:

The numbers shown on the combine display in this illustration are for reference purposes only; they are not intended to represent the specific settings for your equipment.

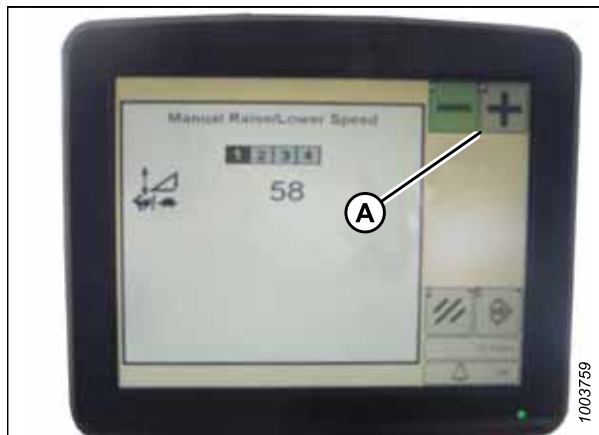


Figure 3.732: John Deere Combine Display

### 3.16.3 Calibrating Auto Header Height Control – John Deere S and T Series

The auto header height control (AHHC) sensor output must be calibrated for each combine, or the AHHC feature will not work properly.

#### DANGER

To prevent bodily injury or death from the unexpected start-up of the machine, always stop the engine and remove the key from the ignition before making adjustments to the machine.

#### DANGER

Ensure that all bystanders have cleared the area.

### NOTE:

Changes may have been made to the combine controls or the display since this document was published. For the most up-to-date information, refer to the combine operator's manual.

### NOTE:

If the header float is set too light, it can prevent the calibration of the AHHC. In order to prevent the header from separating from the float module, it may be necessary to change the float to a heavier setting during calibration.

1. Park the combine on a level surface.
2. Ensure that the header is level with the ground. If adjustment is required:
  - Ensure that the combine is parked on a level surface.
  - If equipped, use the combine's lateral tilt to level the feeder house with the ground.
  - If further adjustment is required, shut the engine off, remove the key from the ignition, and ensure that the combine's tires are inflated to the correct pressure.

### NOTE:

Spirit level (A) is located on top of the float module frame. The header is level if the bubble is in the center of the spirit level.

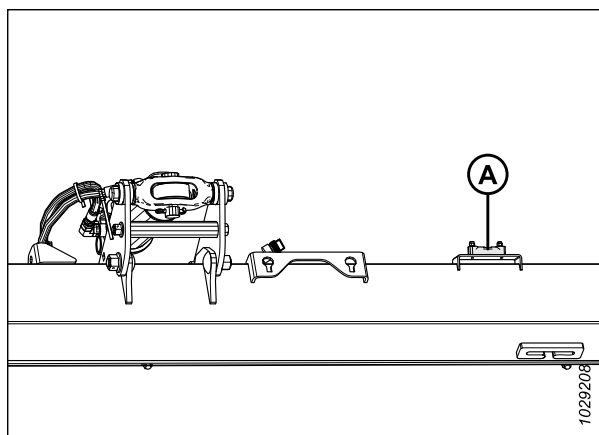


Figure 3.733: Spirit Level



## AUTO HEADER HEIGHT CONTROL SYSTEM

3. Ensure that the center-link is set to **D**.

### NOTE:

When calibration is complete, adjust the center-link back to the desired header angle. For instructions, refer to [3.9.5 Header Angle, page 232](#).

4. Adjust the reel fore-aft position so that the indicator is at position **6**.
5. Position the header so that the cutterbar is 254–356 mm (10–14 in.) off the ground.
6. Shut down the engine, and remove the key from the ignition.



### CAUTION

To prevent cuts, pinches, and other bodily harm to the person checking the down stops, ensure that nobody is manually lifting, bouncing, or moving the header in any way while the down stop washer is being touched and checked for movement.

7. Ensure that the float lock linkage is on the down stops (washer [A] cannot move) at both locations.

### NOTE:

If the header is **NOT** on the down stops, the voltage may go out of range during operation and cause the AHHC system to malfunction. To fix the problem, make the header heavier by decreasing the float. For instructions, refer to [Checking and Adjusting Header Float, page 210](#).

8. Unlock the header float. For instructions, refer to [Locking / Unlocking Header Float, page 221](#).
9. Lock the header wings. For instructions, refer to [Operating in Rigid Mode, page 224](#).

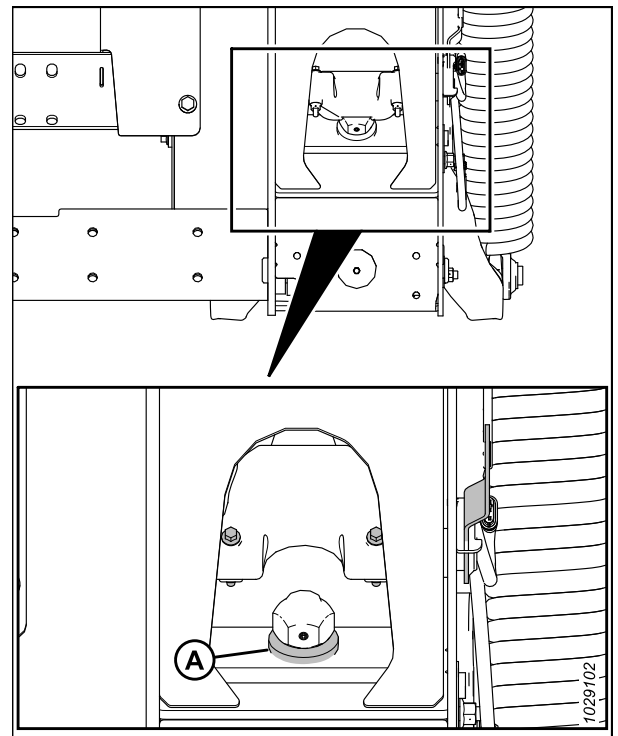


Figure 3.734: Down Stop Washer

## AUTO HEADER HEIGHT CONTROL SYSTEM

10. Select DIAGNOSTIC icon (A) on the main page of the display. The CALIBRATION page appears.



Figure 3.735: John Deere Combine Display

11. Select THRESHING CLEARANCE (A). A list of calibration options appears.

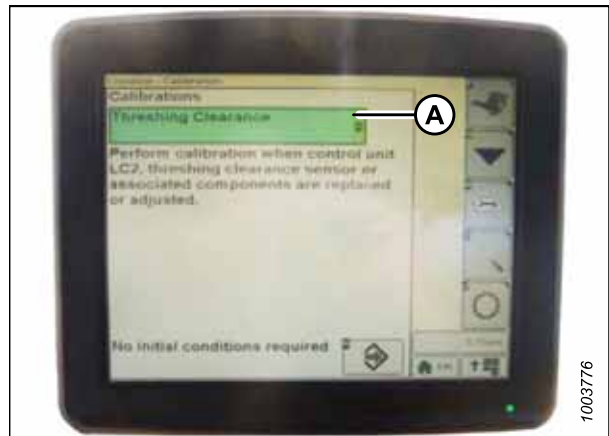


Figure 3.736: John Deere Combine Display

12. Select FEEDER HOUSE SPEED (A) from the list of calibration options.

**NOTE:**

Calibrate the feeder house speed before calibrating the header.

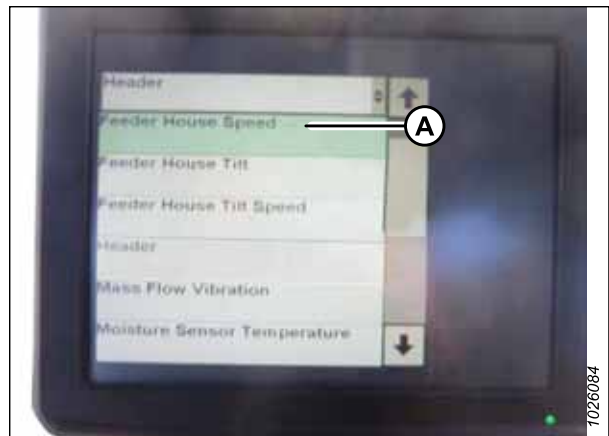


Figure 3.737: John Deere Combine Display

## AUTO HEADER HEIGHT CONTROL SYSTEM

13. With FEEDER HOUSE SPEED selected, select icon (A). The icon turns green.

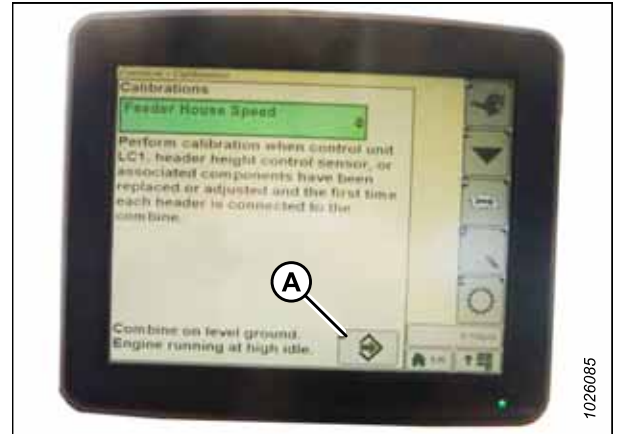


Figure 3.738: John Deere Combine Display

14. Select icon (A). Instructions appear on the screen to guide you through the calibration process.

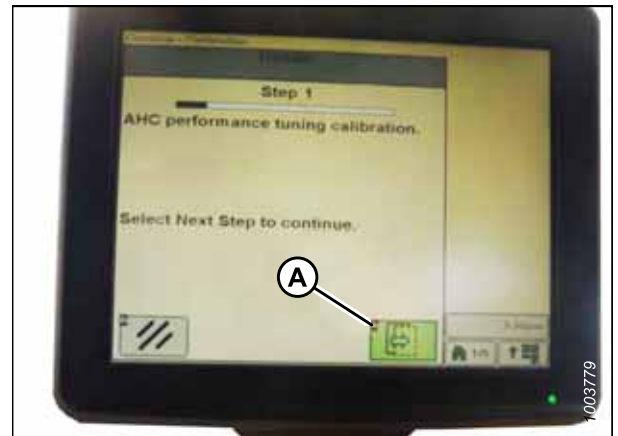


Figure 3.739: John Deere Combine Display

15. Select HEADER (A) from the list of calibration options.

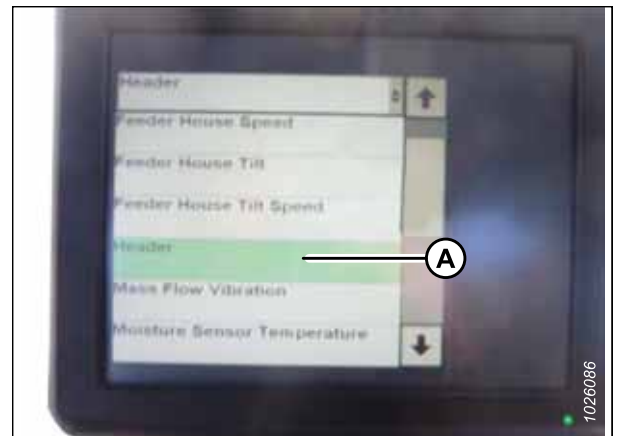


Figure 3.740: John Deere Combine Display

## AUTO HEADER HEIGHT CONTROL SYSTEM

16. With HEADER selected, select icon (A). The icon turns green.

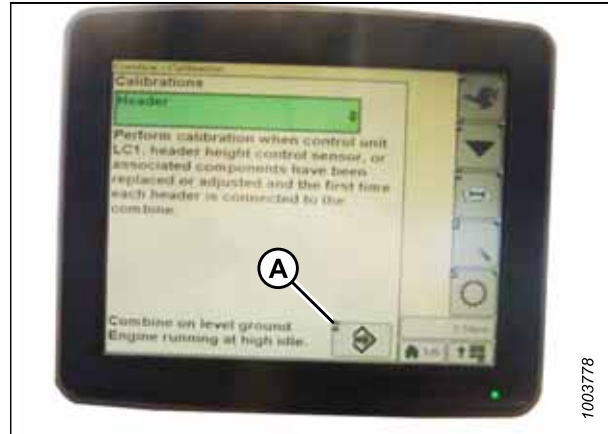


Figure 3.741: John Deere Combine Display

17. Select icon (A). Instructions appear on the screen to guide you through the calibration process.

**NOTE:**

If an error code appears during calibration, the sensor will require adjustment. For instructions, refer to [3.16.1 Checking Voltage Range from Combine Cab – John Deere S and T Series, page 448](#).

**NOTE:**

If the float was set heavier to complete the calibration process, adjust the float to the recommended operating float after calibration is complete.

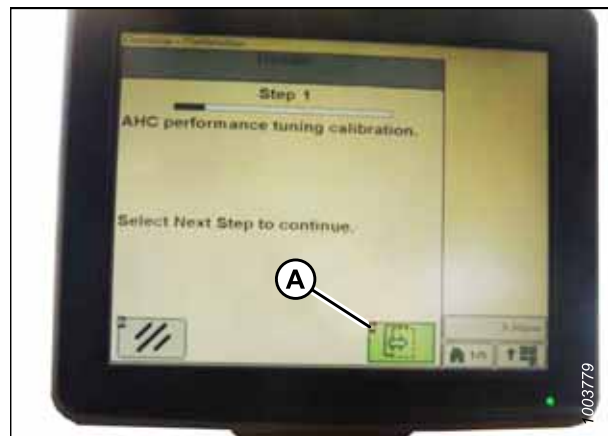


Figure 3.742: John Deere Combine Display

### 3.16.4 Setting Auto Header Height Control Sensitivity – John Deere S and T Series

The sensitivity adjustment controls the distance the cutterbar must travel up or down before the auto header height control (AHHC) reacts and raises or lowers the feeder house.

When the sensitivity is set to maximum, only small changes in ground height raise or lower the feeder house. When the sensitivity is set to minimum, large changes in the ground height will raise or lower the feeder house.

**NOTE:**

Changes may have been made to the combine controls or the display since this document was published. For the most up-to-date information, refer to the combine operator's manual.

## AUTO HEADER HEIGHT CONTROL SYSTEM

1. Press button (A) twice and the current sensitivity setting will appear on the display.



Figure 3.743: John Deere Combine Console

2. Press – or + icons (A) to adjust the rate.

**NOTE:**

The numbers shown on the combine display in this illustration are for reference purposes only; they are not intended to represent the specific settings for your equipment.



Figure 3.744: John Deere Combine Display

### 3.16.5 Setting Preset Cutting Height – John Deere S and T Series

The reel and cut height setting can be stored in the combine's computer as presets. These settings can be set and selected using the combine's control handle.

**NOTE:**

Changes may have been made to the combine controls or the display since this document was published. For the most up-to-date information, refer to the combine operator's manual.

## AUTO HEADER HEIGHT CONTROL SYSTEM

1. Ensure indicator (A) is at position **0** (B) with the header 254–356 mm (10–14 in.) off the ground.

### NOTE:

When the header is on the ground, the indicator should be at position **1** (C) for low ground pressure, and at position **4** (D) for high ground pressure. The crop and soil conditions determine the amount of float to use. The ideal setting is as light as possible without the header bouncing or missing crop. Operating the header with heavy settings prematurely wears the cutterbar wearplates.

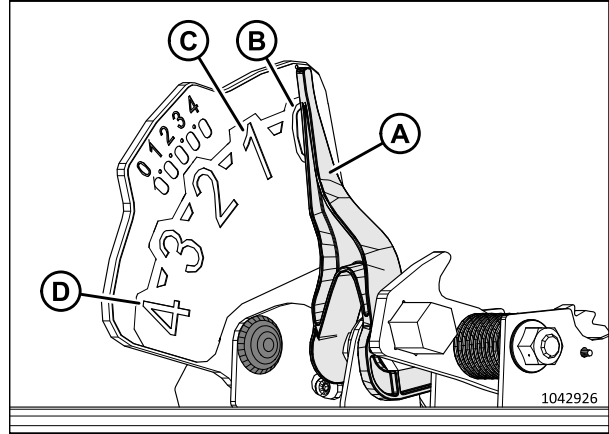


Figure 3.745: Float Indicator

2. Select COMBINE – HEADER SETUP icon (A) on the main page. The COMBINE – HEADER SETUP page appears. This page is used to set various header settings such as reel speed, header width, and height of feeder house for acre counter engagement.



Figure 3.746: Combine Display

3. Select COMBINE – HEADER SETUP AHC icon (A). The COMBINE – HEADER SETUP AHC page appears.



Figure 3.747: Combine Display

## AUTO HEADER HEIGHT CONTROL SYSTEM

4. Select AUTO HEIGHT SENSING (A), RETURN TO CUT (B), and REEL POSITION (C) icons.

**NOTE:**

If REEL POSITION icon (C) cannot be selected (no check mark), the reel height sensor requires calibration. For instructions, refer to [3.16.8 Calibrating Reel Height Sensor and Reel Fore-Aft Sensor – John Deere S and T Series, page 466](#).

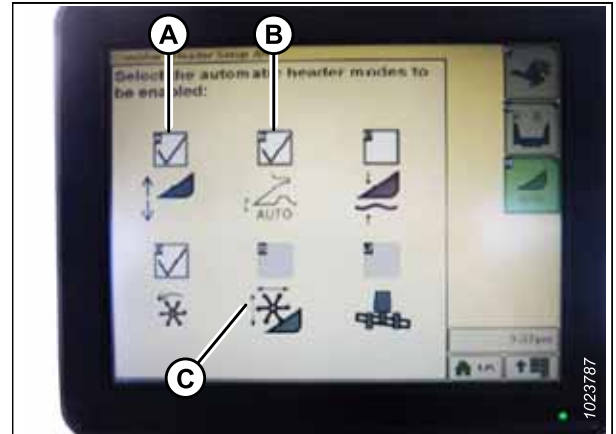


Figure 3.748: Combine Display

5. Engage the header.
6. Move the header to the desired position and use knob (A) to fine tune the position.
7. Move the reel to the desired position.



Figure 3.749: Combine Control Console

8. Press and hold preset switch 2 (B) until the reel height icon flashes on display.
9. Repeat Step 6, page 459 to Step 8, page 459 for preset switch 3 (C).
10. Select an appropriate ground pressure setting. Use preset button 2 (B) on the control handle for a low ground pressure setting in muddy or soft soil conditions, and preset 3 (C) for a high ground pressure setting in firm soil conditions and a higher ground speed.

**NOTE:**

Preset button 1 (A) is reserved for header lift on the headland and is not used for cutting on the ground.



Figure 3.750: Control Handle Buttons



## AUTO HEADER HEIGHT CONTROL SYSTEM

### NOTE:

When the AHHC is engaged, AHHC icon (A) appears on the display and the number indicating which button was pressed (B) is shown on the page.

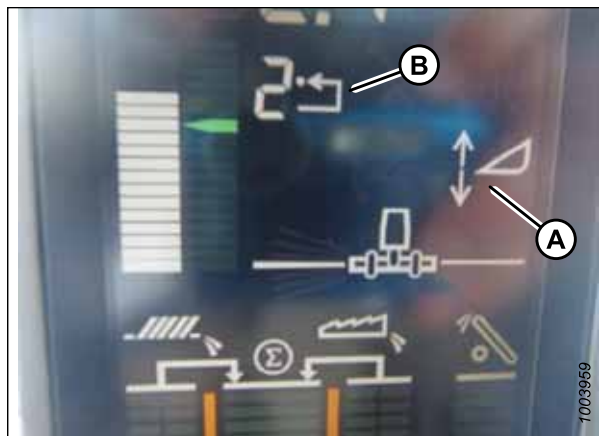


Figure 3.751: Combine Display

### 3.16.6 Calibrating Feeder House Fore-Aft Tilt Range – John Deere S and T Series, Model Year 2015 and Later

Follow this procedure to properly calibrate the combine feeder house fore-aft tilt range.

### NOTE:

Changes may have been made to the combine controls or the display since this document was published. For the most up-to-date information, refer to the combine operator's manual.

### NOTE:

This procedure applies only to model year 2015 and later John Deere S and T Series Combines.

The feeder house fore/aft tilt is controlled by buttons (C) and (D) at the back of the control handle.



Figure 3.752: John Deere Control Handle



## AUTO HEADER HEIGHT CONTROL SYSTEM

### NOTE:

The feeder house fore/aft tilt controls can be changed to work with buttons E and F by selecting control handle icon (A) and then selecting FEEDER HOUSE FORE/AFT TILT from drop-down menu (B).

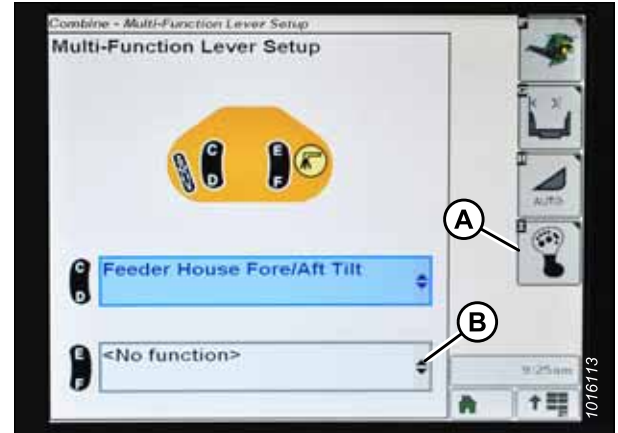


Figure 3.753: John Deere Combine Display

To calibrate the feeder house fore-aft tilt range, follow these steps:

1. Ensure that the center-link is set to **D**.

### NOTE:

When setup and calibration are complete, adjust the center-link back to the desired header angle. For instructions, refer to [3.9.5 Header Angle, page 232](#).

2. Rest the header on the down stops.
3. Unlock the header float. For instructions, refer to [Locking / Unlocking Header Float, page 221](#).
4. Select **DIAGNOSTIC** icon (A) on the main page of the display. The **CALIBRATION** page appears.



Figure 3.754: John Deere Combine Display

## AUTO HEADER HEIGHT CONTROL SYSTEM

5. Select CALIBRATIONS drop-down menu (A) to view the list of calibration options.

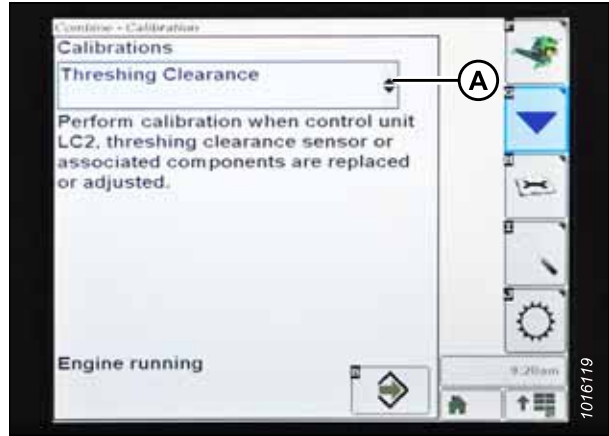


Figure 3.755: John Deere Combine Display

6. Select arrow (A) to cycle up through the calibration options and select FEEDER HOUSE FORE/AFT TILT RANGE.

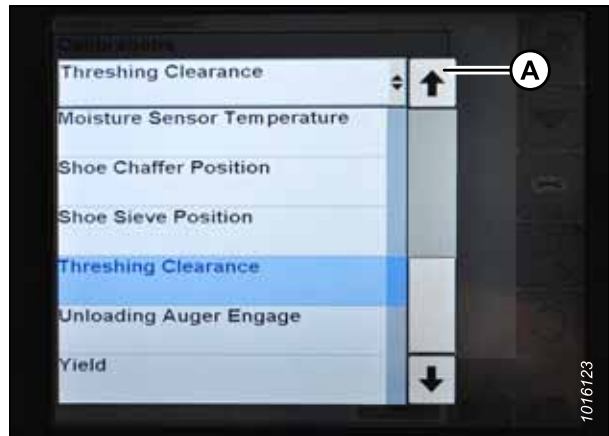


Figure 3.756: John Deere Combine Display

7. Select ENTER icon (A).

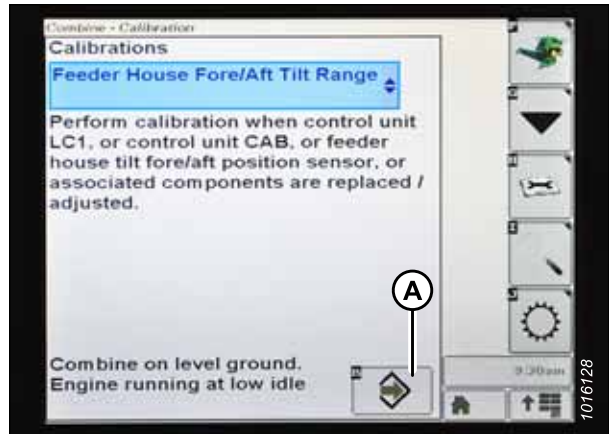


Figure 3.757: John Deere Combine Display

## AUTO HEADER HEIGHT CONTROL SYSTEM

- Follow the instructions on the page. As you proceed through the calibration process, the display automatically updates to show the next step.

**NOTE:**

If an error code appears during calibration, the sensor will require adjustment. For instructions, refer to [3.16.1 Checking Voltage Range from Combine Cab – John Deere S and T Series, page 448](#).

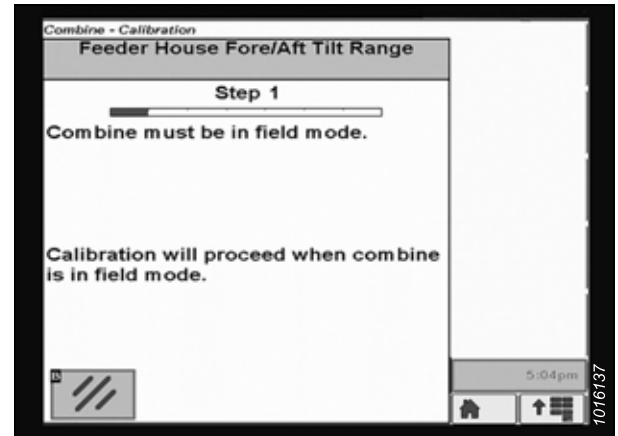


Figure 3.758: John Deere Combine Display

### 3.16.7 Checking Reel Height Sensor Voltages – John Deere S and T Series

Check the reel height sensor voltages to ensure that they are within the required range.

**NOTE:**

Changes may have been made to the combine controls or the display since this document was published. For the most up-to-date information, refer to the combine operator's manual.

- Select CALIBRATION icon (A) on the main page of the display. The CALIBRATION page appears.



Figure 3.759: John Deere Combine Display

## AUTO HEADER HEIGHT CONTROL SYSTEM

2. Select DIAGNOSTIC READINGS icon (A) on the CALIBRATION page. The DIAGNOSTIC READINGS page appears. This page provides access to calibrations, header options, and diagnostic information.

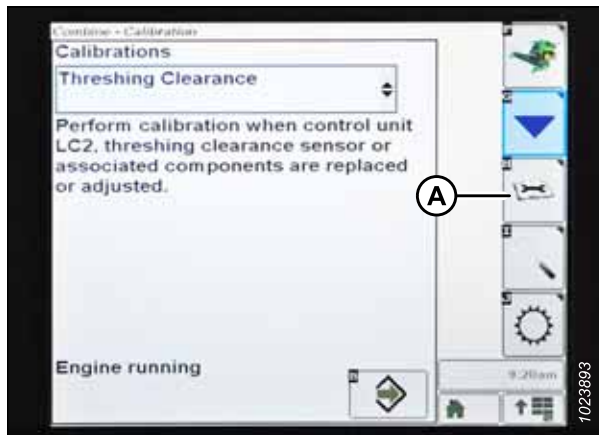


Figure 3.760: John Deere Combine Display

3. Select drop-down menu (A) to view the list of calibration options.

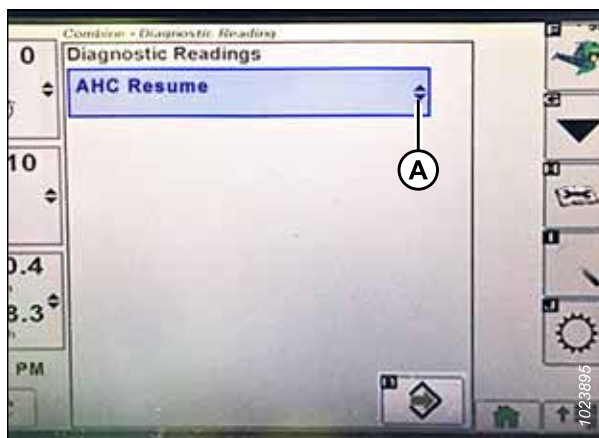


Figure 3.761: John Deere Combine Display

4. Scroll down and select REEL RESUME (A).



Figure 3.762: John Deere Combine Display

## AUTO HEADER HEIGHT CONTROL SYSTEM

5. Select ENTER icon (A). The REEL RESUME page appears.

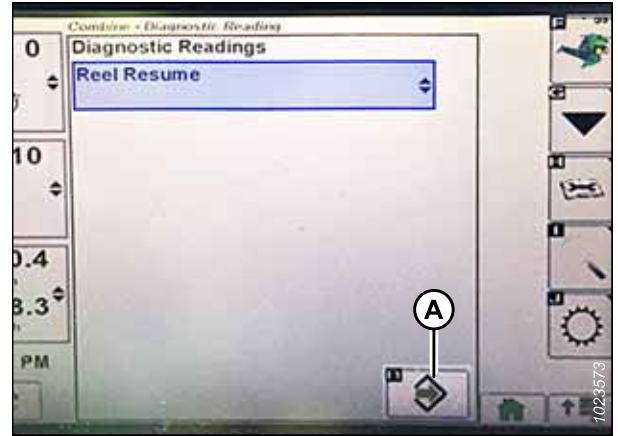


Figure 3.763: John Deere Combine Display

6. Select NEXT PAGE icon (A) to cycle to page 3.
7. Lower the reel to view lower voltage limit (B). The voltage should be within 0.5–0.9 V.

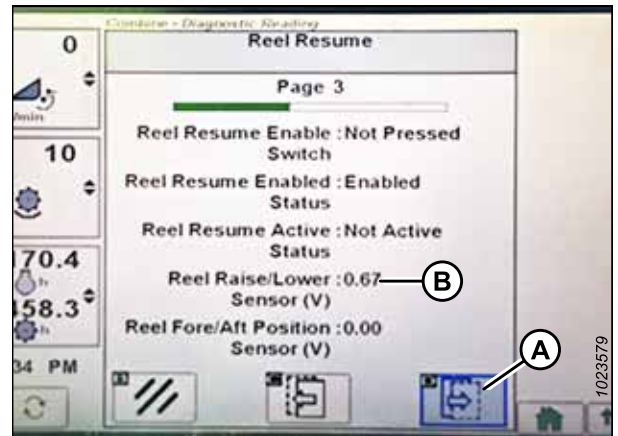


Figure 3.764: John Deere Combine Display

8. Raise the reel to view upper voltage limit (A). The voltage should be within 4.1–4.3 V.
9. If either voltage is not within the correct range, refer to [Checking and Adjusting Reel Height Sensor, page 248](#).

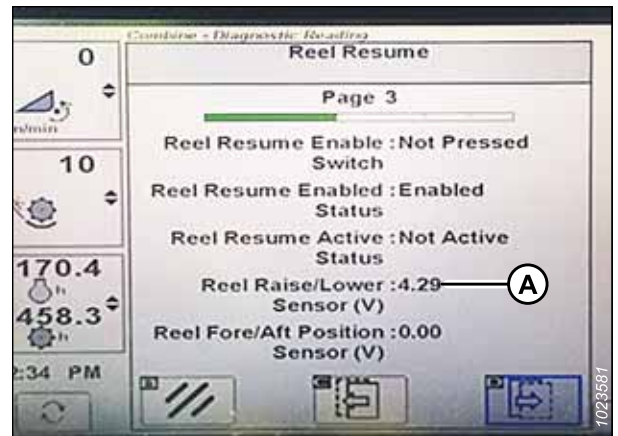


Figure 3.765: John Deere Combine Display

### 3.16.8 Calibrating Reel Height Sensor and Reel Fore-Aft Sensor – John Deere S and T Series

The auto header height control (AHHC) sensor output must be calibrated for each combine, or the reel position feature will not work properly. The following procedure applies only to model year 2015 and later John Deere S and T Series Combines.

**NOTE:**

Changes may have been made to the combine controls or the display since this document was published. For the most up-to-date information, refer to the combine operator’s manual.

**⚠ DANGER**

Ensure that all bystanders have cleared the area.

1. Start the engine.
2. Position the header 254–356 mm (10–14 in.) off the ground.

**IMPORTANT:**

Do **NOT** turn off the engine. The combine has to be at a full idle to properly calibrate the sensors.

3. Select DIAGNOSTIC icon (A) on the main page of the display. The CALIBRATION page is shown.



Figure 3.766: John Deere Combine Display

4. Select CALIBRATIONS drop-down menu (A) to view the list of calibration options.
5. Scroll through the list of options and select REEL POSITION.
6. Select ENTER icon (B).

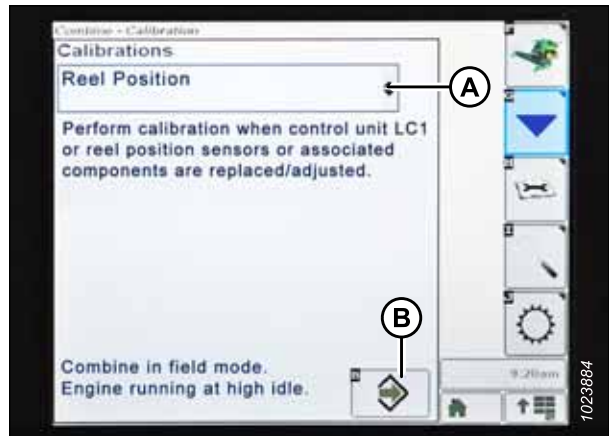


Figure 3.767: John Deere Combine Display



## AUTO HEADER HEIGHT CONTROL SYSTEM

7. Follow the instructions that appear on the page. As you proceed through the calibration process, the display will automatically update to show the next step. This calibration requires you to use reel raise (A) and reel lower (B) switches on the control handle.



Figure 3.768: John Deere Control Handle

8. Press and hold the REEL LOWER switch until the reel is fully lowered. Continue holding the REEL LOWER switch until prompted by the display.



Figure 3.769: John Deere Combine Display

9. Press and hold the REEL RAISE switch until the reel is fully raised. Continue holding the REEL RAISE switch until prompted by the display.



Figure 3.770: John Deere Combine Display

## AUTO HEADER HEIGHT CONTROL SYSTEM

- When all steps have been completed, CALIBRATION COMPLETE message is displayed on the page. Exit the CALIBRATION menu by pressing ENTER icon (A).

**NOTE:**

If an error code appears during calibration, the sensor will require adjustment. For instructions, refer to [3.16.7 Checking Reel Height Sensor Voltages – John Deere S and T Series, page 463](#).



Figure 3.771: John Deere Combine Display



### 3.17 John Deere S7 Series Combines

To make your header’s auto header height control (AHHC) system compatible with John Deere S7 Series combines, you must set your combine’s header configuration options for the particular model of header, configure the reel speed settings, set up the AHHC controls, and calibrate the AHHC system to ensure that it is working correctly.

#### 3.17.1 Setting up Header – John Deere S7 Series

Set these initial configuration options on your combine when setting up the auto header height control (AHHC) system.

**NOTE:**

Changes may have been made to the combine controls or the display since this document was published. For the most up-to-date information, refer to the combine operator’s manual.

1. Press HEADER button (A) on the panel below the display. The HEADER page appears.



Figure 3.772: John Deere S7 Display

2. Select HEADER TYPE field (A). The HEADER DETAILS dialog box opens.

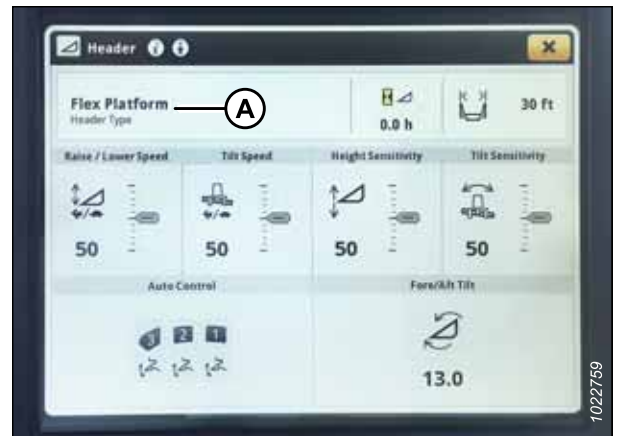


Figure 3.773: John Deere S7 Display – Header Page

## AUTO HEADER HEIGHT CONTROL SYSTEM

3. Verify the correct header width is displayed under WIDTH.
4. To change the header width, select field (A). The WIDTH dialog box opens.



Figure 3.774: John Deere S7 Display – Header Details Window

5. Use the on-screen keypad to enter the correct header width, and then select OK.



Figure 3.775: John Deere S7 Display – Setting Header Width

6. Select close button (A) in the top right corner to return to the HEADER page.



Figure 3.776: John Deere S7 Display – Header Details Dialog Box

## AUTO HEADER HEIGHT CONTROL SYSTEM

7. Raise/lower speed (A), tilt speed (B), height sensitivity (C), and tilt sensitivity (D) can be adjusted from this page. Select the option you would like to adjust. The following example shows the raise/lower speed adjustment.

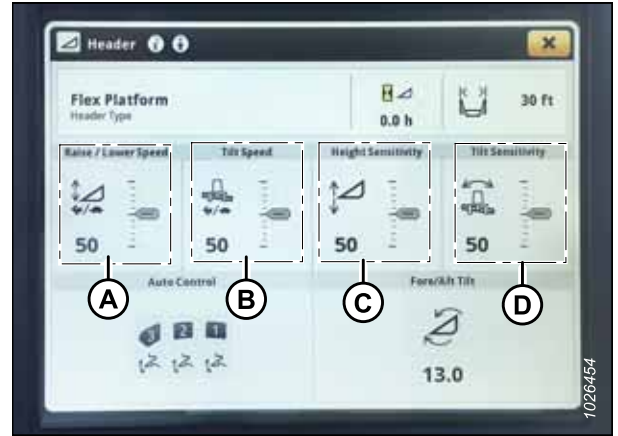


Figure 3.777: John Deere S7 Display – Header Page

8. Use + and – buttons (A) to adjust the setting.
9. Select the X button in the top right corner of the window to return to the HEADER page.

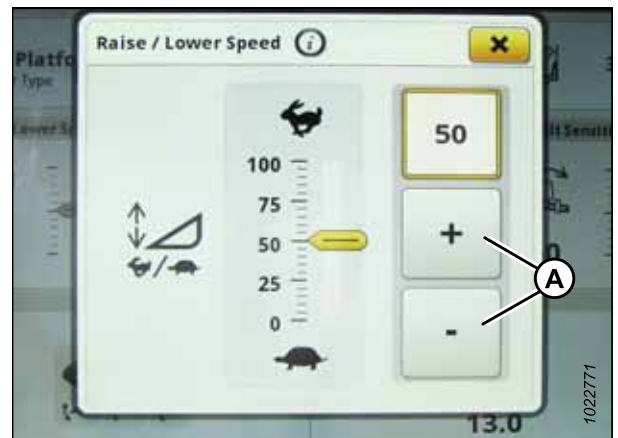


Figure 3.778: John Deere S7 Display – Raise/Lower Speed Adjustment

10. Select AUTO CONTROL icons (A). The AUTO HEADER CONTROLS page opens.



Figure 3.779: John Deere S7 Display – Header Page

## AUTO HEADER HEIGHT CONTROL SYSTEM

11. If the header has not been calibrated yet, an error icon will appear on HEIGHT SENSING button (A). Select button (A) to view the error message.

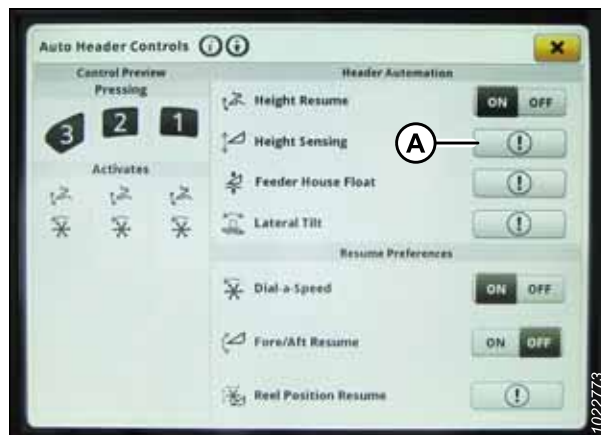


Figure 3.780: John Deere S7 Display – Auto Header Controls

12. Read the error message, then select OK.
13. Proceed to [3.17.2 Checking Voltage Range from Combine Cab – John Deere S7 Series, page 472](#).

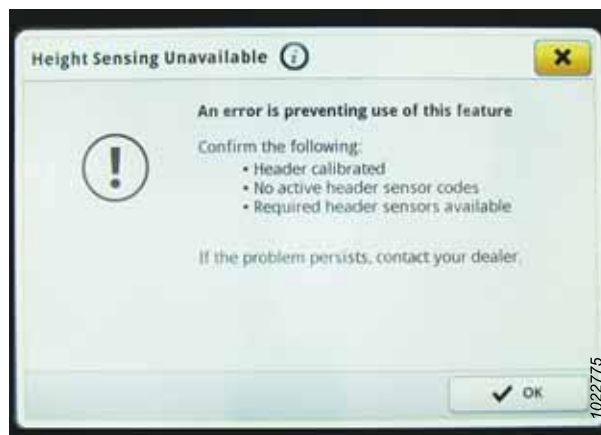


Figure 3.781: John Deere S7 Display – Height Sensing Error Message

### 3.17.2 Checking Voltage Range from Combine Cab – John Deere S7 Series

The auto header height control (AHHC) sensor output must be within a specific range, or the feature will not work properly.

#### NOTE:

Changes may have been made to the combine controls or the display since this document was published. For the most up-to-date information, refer to the combine operator's manual.

#### DANGER

To prevent bodily injury or death from the unexpected start-up of the machine, always stop the engine and remove the key from the ignition before making adjustments to the machine.

#### DANGER

Ensure that all bystanders have cleared the area.

1. Position the header so that the cutterbar is 254–356 mm (10–14 in.) off the ground.
2. Shut down the engine, and remove the key from the ignition.

## AUTO HEADER HEIGHT CONTROL SYSTEM

3. Unlock the header float. For instructions, refer to *Locking / Unlocking Header Float, page 221*.
4. Lock the header wings. For instructions, refer to *Operating in Rigid Mode, page 224*.

### CAUTION

To prevent cuts, pinches, and other bodily harm to the person checking the down stops, ensure that nobody is manually lifting, bouncing, or moving the header in any way while the down stop washer is being touched and checked for movement.

5. Ensure that the float lock linkage is on the down stops (washer [A] cannot move) at both locations.

#### NOTE:

If the header is **NOT** on the down stops, the voltage may go out of range during operation and cause the AHC system to malfunction. To fix the problem, make the header heavier by decreasing the float. For instructions, refer to *Checking and Adjusting Header Float, page 210*.

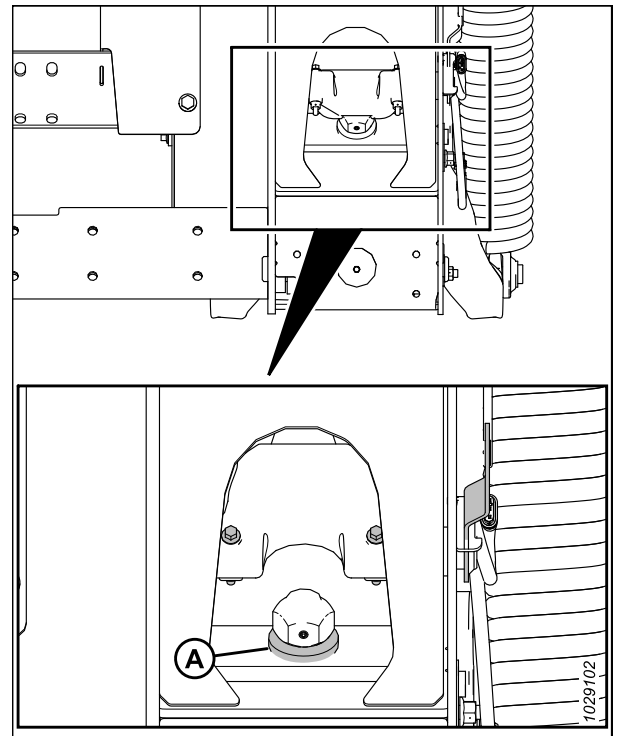


Figure 3.782: Down Stop Washer

6. If the pointer is not on zero, loosen bolt (A) and rotate float indicator plate (B) until pointer (C) is on 0 (D). Tighten the nut on bolt (A).

#### NOTE:

Use zero dot (E) above the decal to correctly set the indicator needle.

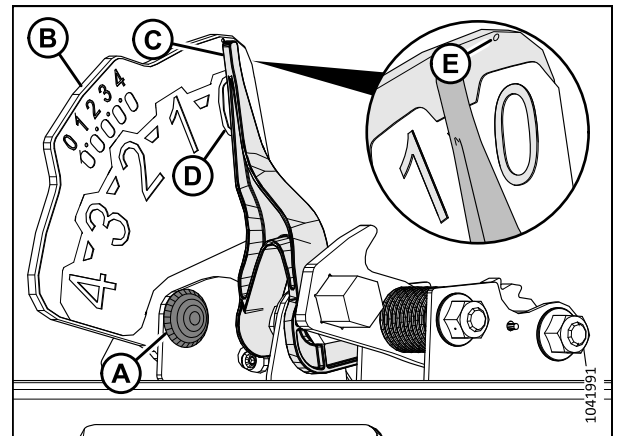


Figure 3.783: Float Indicator

## AUTO HEADER HEIGHT CONTROL SYSTEM

- On the HARVESTING page, select MENU icon (A) in the bottom right corner of the page.



Figure 3.784: John Deere S7 Display – Harvesting Page

- On the MENU page, select SYSTEM tab (A). The MENU opens.
- Select DIAGNOSTICS CENTER icon (B). The DIAGNOSTICS CENTER page opens.

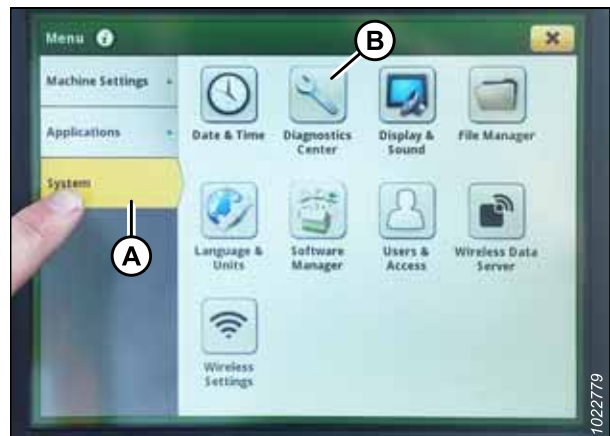


Figure 3.785: John Deere S7 Display – Menu

- Select AHC - SENSING (A). The AHC - SENSING \DIAGNOSTICS page appears.

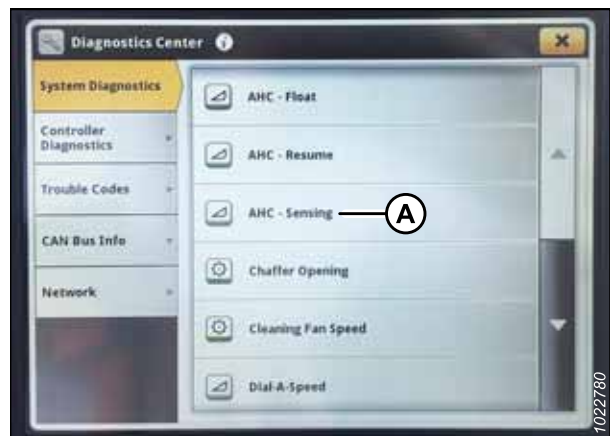


Figure 3.786: John Deere S7 Display – Diagnostics Center

## AUTO HEADER HEIGHT CONTROL SYSTEM

11. Select SENSOR tab (A) to view the sensor voltages. Center header height sensor voltage (B) must be between 0.7 and 4.3 V, with at least 3 V of variation between 0 and 4 on the float indicator box.
12. If the sensor voltage is not within the lower and upper limits, or if the range between the lower and upper limits is insufficient, refer to [3.3 Manually Checking Voltage Limits](#), page 296.

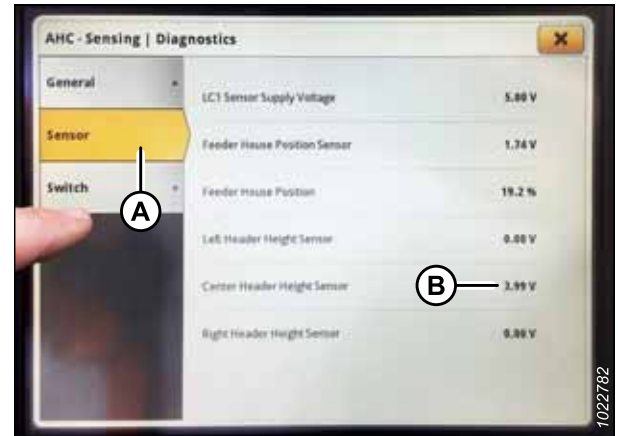


Figure 3.787: John Deere S7 Display – Checking Sensor Voltage

### 3.17.3 Calibrating Feeder House – John Deere S7 Series

The feeder house must be calibrated before calibrating the header.

#### DANGER

Ensure that all bystanders have cleared the area.

#### NOTE:

Changes may have been made to the combine controls or the display since this document was published. For the most up-to-date information, refer to the combine operator's manual.

1. Start the engine.
2. Ensure that the center-link is set to D.

#### NOTE:

When calibration is complete, adjust the center-link back to the desired header angle. For instructions, refer to [3.9.5 Header Angle](#), page 232.

3. Rest the header on the down stops.
4. Unlock the header float. For instructions, refer to [Locking / Unlocking Header Float](#), page 221.
5. Shut down the engine, and remove the key from the ignition.



## AUTO HEADER HEIGHT CONTROL SYSTEM

- On the HARVESTING page, select MENU icon (A) in the bottom right corner of page. The MENU opens.



Figure 3.788: John Deere S7 Display – Harvesting Page

- Select MACHINE SETTINGS tab (A).
- Select CALIBRATIONS & PROCEDURES icon (B). The CALIBRATIONS & PROCEDURES page appears.



Figure 3.789: John Deere S7 Display – Machine Settings

- Select HEADER tab (A).
- Select FEEDER HOUSE RAISE SPEED CALIBRATION (B). The FH RAISE SPEED CALIBRATION page appears.

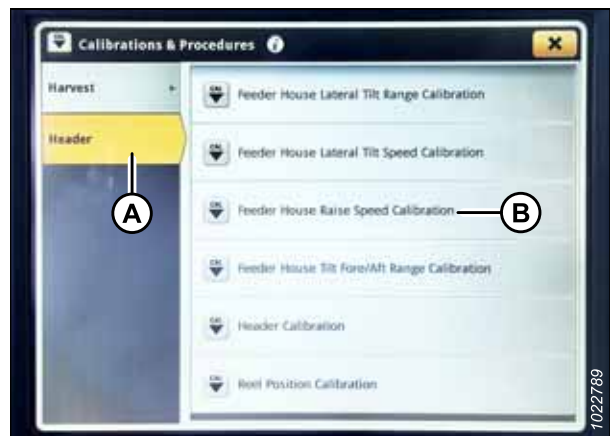


Figure 3.790: John Deere S7 Display – Calibrations and Procedures

## AUTO HEADER HEIGHT CONTROL SYSTEM

11. Select CALIBRATE (A) at the bottom of the page. A calibration overview appears.

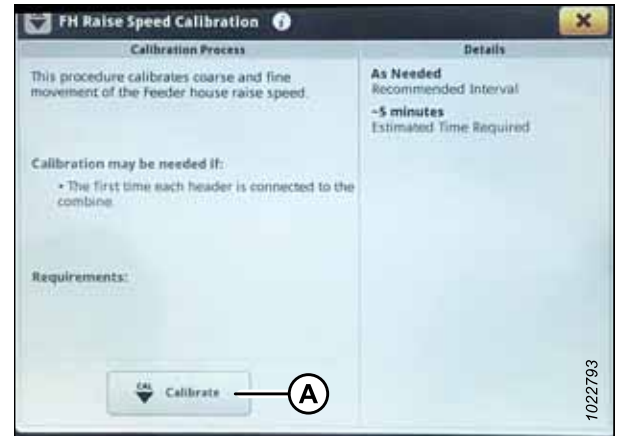


Figure 3.791: John Deere S7 Display – Feeder House Calibration

12. Read the calibration overview, then press START.



Figure 3.792: John Deere S7 Display – Feeder House Calibration

13. Follow the instructions on the page. As you proceed through the calibration process, the display automatically updates to show the next step.



Figure 3.793: John Deere S7 Display – Feeder House Calibration

## AUTO HEADER HEIGHT CONTROL SYSTEM

14. When calibration is complete, select SAVE.



Figure 3.794: John Deere S7 Display – Feeder House Calibration

### 3.17.4 Calibrating Header – John Deere S7 Series

Before the auto header height control (AHHC) system can be used, the header must be calibrated.

The feeder house must be calibrated before calibrating the header. If the feeder house has not yet been calibrated, refer to [3.17.3 Calibrating Feeder House – John Deere S7 Series, page 475](#).

#### DANGER

To prevent bodily injury or death from the unexpected start-up of the machine, always stop the engine and remove the key from the ignition before making adjustments to the machine.

#### DANGER

Ensure that all bystanders have cleared the area.

#### NOTE:

Changes may have been made to the combine controls or the display since this document was published. For the most up-to-date information, refer to the combine operator's manual.

#### NOTE:

If the header float is set too light, it can prevent the calibration of the AHHC. In order to prevent the header from separating from the float module, it may be necessary to change the float to a heavier setting during calibration.

## AUTO HEADER HEIGHT CONTROL SYSTEM

1. Park the combine on a level surface.
2. Ensure that the header is level with the ground. If adjustment is required:
  - Ensure that the combine is parked on a level surface.
  - If equipped, use the combine's lateral tilt to level the feeder house with the ground.
  - If further adjustment is required, shut the engine off, remove the key from the ignition, and ensure that the combine's tires are inflated to the correct pressure.

**NOTE:**

Spirit level (A) is located on top of the float module frame. The header is level if the bubble is in the center of the spirit level.

3. Ensure that the center-link is set to **D**.

**NOTE:**

When calibration is complete, adjust the center-link back to the desired header angle. For instructions, refer to [3.9.5 Header Angle, page 232](#).

4. Adjust the reel fore-aft position so that the indicator is at position **6**.
5. Position the header so that the cutterbar is 254–356 mm (10–14 in.) off the ground.
6. Shut down the engine, and remove the key from the ignition.

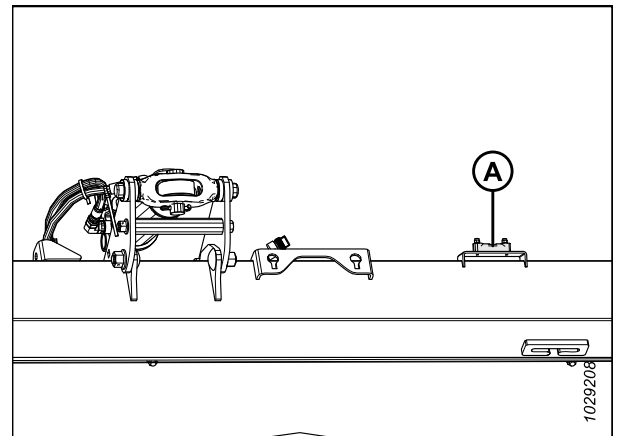


Figure 3.795: Spirit Level

## AUTO HEADER HEIGHT CONTROL SYSTEM

### CAUTION

To prevent cuts, pinches, and other bodily harm to the person checking the down stops, ensure that nobody is manually lifting, bouncing, or moving the header in any way while the down stop washer is being touched and checked for movement.

7. Ensure that the float lock linkage is on the down stops (washer [A] cannot move) at both locations.

#### NOTE:

If the header is **NOT** on the down stops, the voltage may go out of range during operation and cause the AHHC system to malfunction. To fix the problem, make the header heavier by decreasing the float. For instructions, refer to [Checking and Adjusting Header Float, page 210](#).

8. Unlock the header float. For instructions, refer to [Locking / Unlocking Header Float, page 221](#).
9. Lock the header wings. For instructions, refer to [Operating in Rigid Mode, page 224](#).

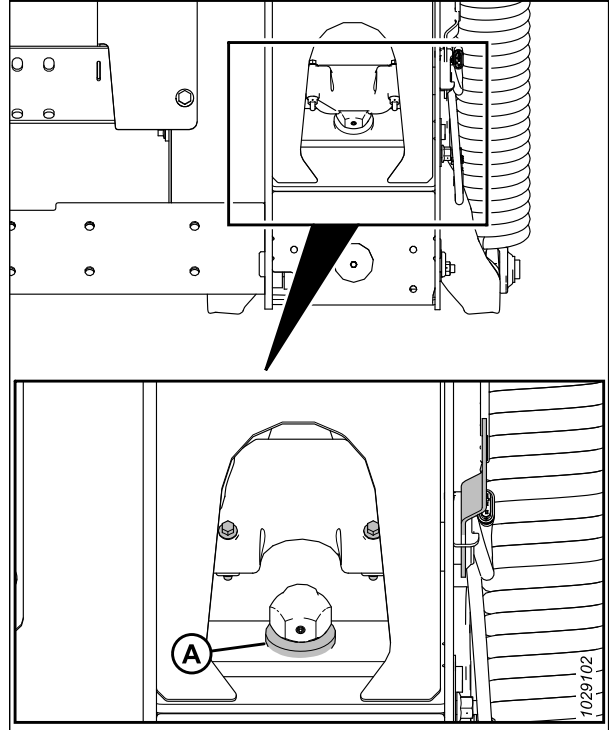


Figure 3.796: Down Stop Washer

10. On the HARVESTING page, select MENU icon (A) in the bottom right corner of screen. The MENU opens.



Figure 3.797: John Deere S7 Display – Harvesting Page

## AUTO HEADER HEIGHT CONTROL SYSTEM

11. Select MACHINE SETTINGS tab (A).
12. Select CALIBRATIONS & PROCEDURES icon (B). The CALIBRATIONS & PROCEDURES page appears.

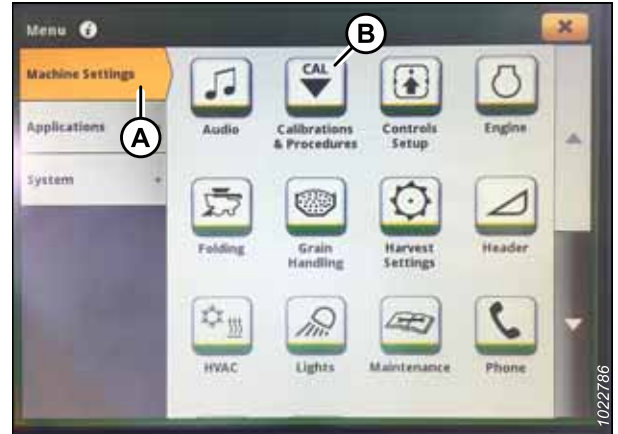


Figure 3.798: John Deere S7 Display – Machine Settings

13. Select HEADER tab (A).
14. Select HEADER CALIBRATION (B). The HEADER CALIBRATION page appears.

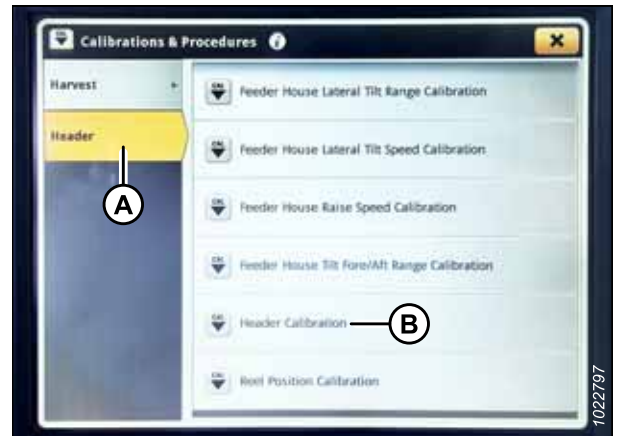


Figure 3.799: John Deere S7 Display – Calibrations and Procedures

15. Select CALIBRATE (A) at the bottom of the page. The calibration overview window opens.

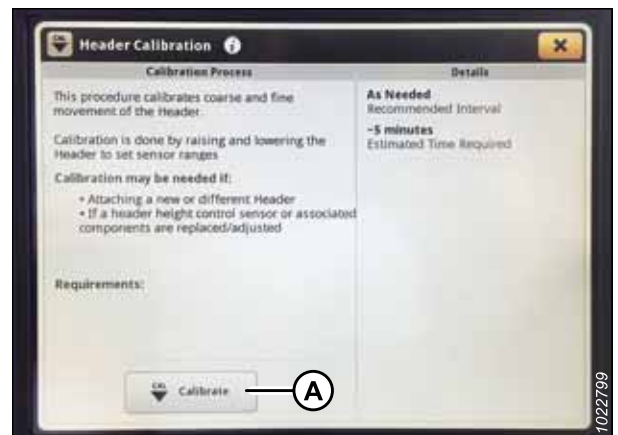


Figure 3.800: John Deere S7 Display – Header Calibration

## AUTO HEADER HEIGHT CONTROL SYSTEM

16. Press button (A) on the console to set the engine to full throttle.



Figure 3.801: John Deere S7 Console

17. Select START on the CALIBRATION OVERVIEW page.
18. Follow the instructions that appear on the combine display. As you proceed through the calibration process, the display automatically updates to show the next step.



Figure 3.802: John Deere S7 Display – Header Calibration

19. When the calibration is complete, select SAVE.



Figure 3.803: John Deere S7 Display – Header Calibration



## 3.18 John Deere X9 Series Combines

To make your header's auto header height control (AHHC) system compatible with the combine, you must set your combine's header configuration options for the particular model of header, configure the touch screen settings, set up the AHHC controls, and calibrate the AHHC system to ensure that it is working correctly.

**NOTE:**

Some John Deere X9 combines require an auto-tilt calibration before an auto header height control (AHHC) calibration.

### 3.18.1 Setting up Header in CommandCenter™ Display – John Deere X9 Series

The main header auto header height control (AHHC) settings can be configured in the CommandCenter™ Display in the combine cab.

**NOTE:**

Changes may have been made to the combine controls or the display since this document was published. For the most up-to-date information, refer to the combine operator's manual.

**NOTE:**

Certain models may need to have an auto-tilt calibration completed prior to the AHHC calibration.

 **DANGER**

Ensure that all bystanders have cleared the area.

1. Start the engine.
2. Press HEADER button (A) on the panel below the display. The HEADER page opens.



Figure 3.804: CommandCenter™ Display

## AUTO HEADER HEIGHT CONTROL SYSTEM

3. Ensure that header type (A) and size (B) are correct.

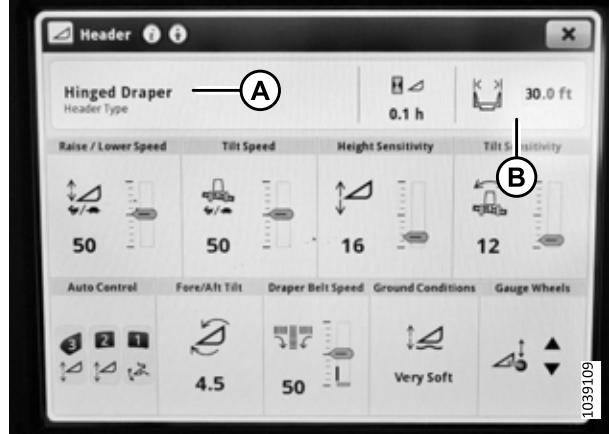


Figure 3.805: CommandCenter™ Display – Header Page

4. Select AUTO CONTROL (A). The AUTO HEADER CONTROLS page opens.

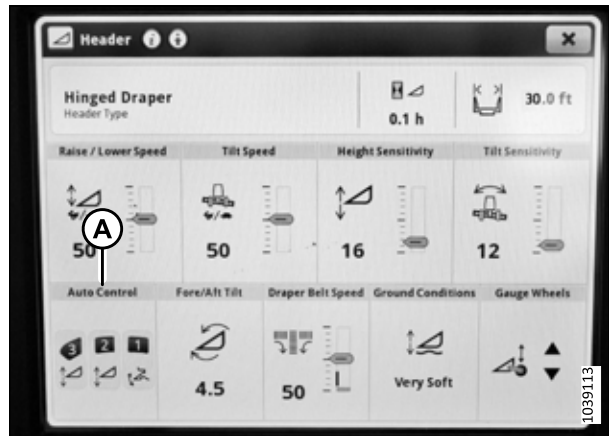


Figure 3.806: CommandCenter™ Display – Auto Header Controls Page

5. On the AUTO HEADER CONTROLS page, ensure that the following HEADER AUTOMATION OPTIONS are set to ON:

- HEIGHT RESUME
- HEIGHT SENSING
- LATERAL TILT

6. Ensure the following RESUME PREFERENCES are set to ON:

- AUTO REEL SPEED
- FORE/AFT RESUME
- REEL POSITION RESUME

7. Set any other settings in the AUTO HEADER CONTROLS PAGE not referred to in the previous two steps to OFF. Press the X in the corner of the window to exit the page.

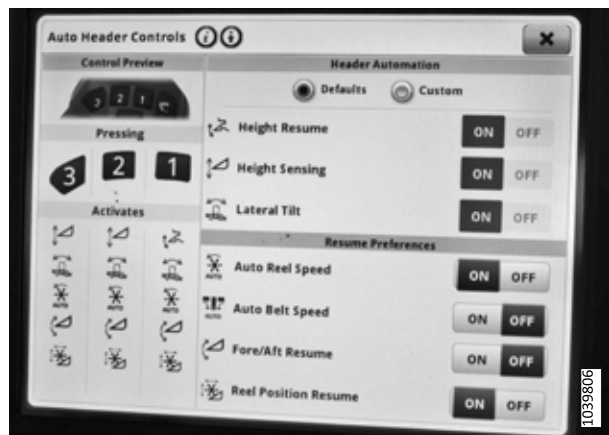


Figure 3.807: CommandCenter™ Display – Auto Header Controls Page

## AUTO HEADER HEIGHT CONTROL SYSTEM

- On the HEADER page, select HEIGHT SENSITIVITY (A). Change the setting to 10.
- Select TILT SENSITIVITY (B). Change the setting to 10.
- Press X (C) to exit the HEADER page.



Figure 3.808: CommandCenter™ Display – Header Page

### 3.18.2 Calibrating Auto Header Height Control – John Deere X9 Series

The auto header height control (AHHC) sensor output must be calibrated for each combine, or the AHHC feature will not work properly.

#### DANGER

To prevent bodily injury or death from the unexpected start-up of the machine, always stop the engine and remove the key from the ignition before making adjustments to the machine.

#### DANGER

Ensure that all bystanders have cleared the area.

#### NOTE:

Changes may have been made to the combine controls or the display since this document was published. For the most up-to-date information, refer to the combine operator's manual.

#### NOTE:

If the header float is set too light, it can prevent the calibration of the AHHC. In order to prevent the header from separating from the float module, it may be necessary to change the float to a heavier setting during calibration.

- Park the combine on a level surface.
- If the combine requires an auto-tilt calibration before an auto header height (AHHC) calibration, then perform an auto-tilt calibration now. For instructions, refer to the combine operator's manual.

## AUTO HEADER HEIGHT CONTROL SYSTEM

3. Ensure that the header is level with the ground. If adjustment is required:
  - Ensure that the combine is parked on a level surface.
  - If equipped, use the combine's lateral tilt to level the feeder house with the ground.
  - If further adjustment is required, shut the engine off, remove the key from the ignition, and ensure that the combine's tires are inflated to the correct pressure.

### NOTE:

Spirit level (A) is located on top of the float module frame. The header is level if the bubble is in the center of the spirit level.

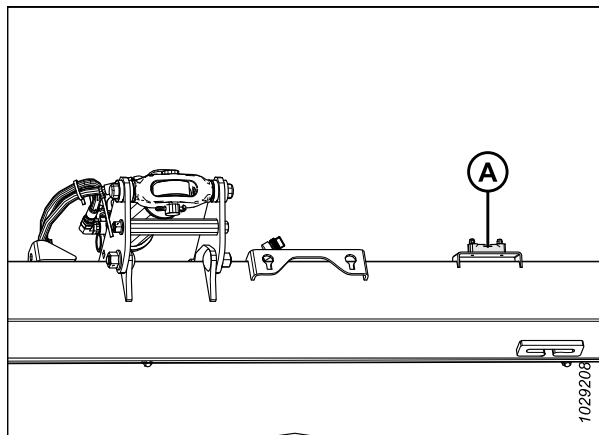


Figure 3.809: Spirit Level

4. Ensure that the center-link is set to **D**.

### NOTE:

When calibration is complete, adjust the center-link back to the desired header angle. For instructions, refer to [3.9.5 Header Angle, page 232](#).

5. Adjust the reel fore-aft position so that the indicator is at position **6**.
6. Position the header so that the cutterbar is 254–356 mm (10–14 in.) off the ground.
7. Shut down the engine, and remove the key from the ignition.

## CAUTION

To prevent cuts, pinches, and other bodily harm to the person checking the down stops, ensure that nobody is manually lifting, bouncing, or moving the header in any way while the down stop washer is being touched and checked for movement.

8. Ensure that the float lock linkage is on the down stops (washer [A] cannot move) at both locations.

### NOTE:

If the header is **NOT** on the down stops, the voltage may go out of range during operation and cause the AHHC system to malfunction. To fix the problem, make the header heavier by decreasing the float. For instructions, refer to [Checking and Adjusting Header Float, page 210](#).

9. Unlock the header float. For instructions, refer to [Locking / Unlocking Header Float, page 221](#).
10. Lock the header wings. For instructions, refer to [Operating in Rigid Mode, page 224](#).

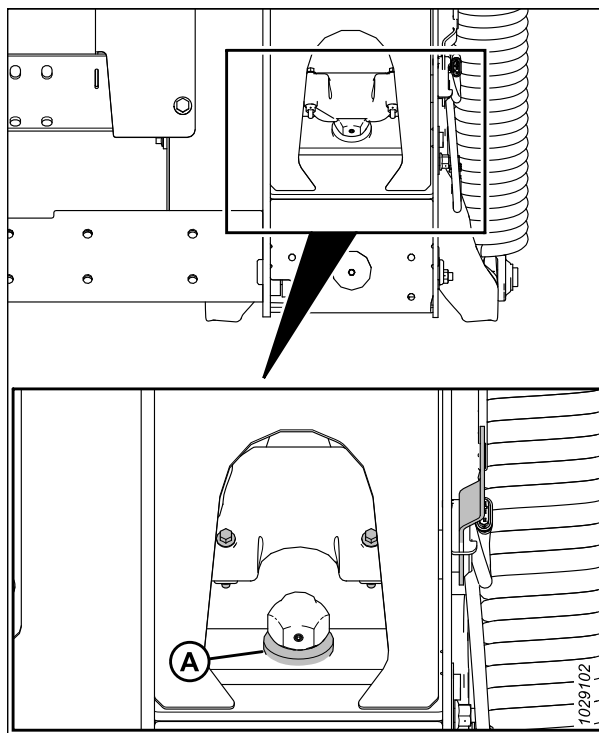


Figure 3.810: Down Stop Washer

## AUTO HEADER HEIGHT CONTROL SYSTEM

11. Move the reel to fore-aft position 6.
12. On the CommandCenter™ display, select MENU icon (A) in the bottom right corner of the HARVESTING page. The MENU appears.



Figure 3.811: John Deere X9 Display – Harvesting Page

13. Select MACHINE SETTINGS tab (A).
14. Select CALIBRATIONS & PROCEDURES icon (B). The CALIBRATIONS & PROCEDURES page appears.



Figure 3.812: John Deere X9 Display – Machine Settings

15. Select HEADER tab (A).
16. Select GAUGE WHEEL RANGE CALIBRATION (B). The GAUGE WHEEL RANGE CALIBRATION page appears.
17. Follow the instructions on the page. As you proceed through the calibration process, the display will automatically update to show the next step.
18. Select SAVE to confirm the calibration.

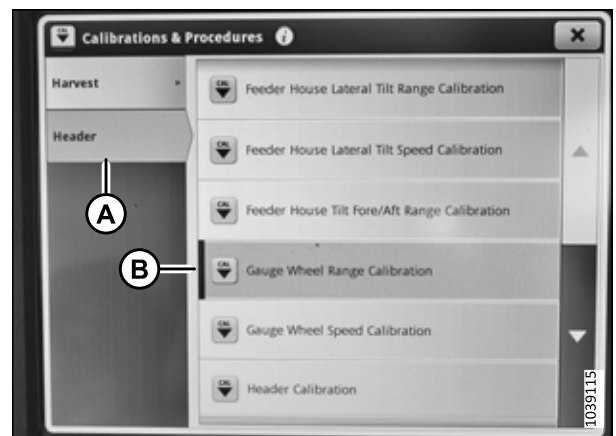


Figure 3.813: John Deere X9 Display – Gauge Wheel Range Calibration

## AUTO HEADER HEIGHT CONTROL SYSTEM

19. Select HEADER CALIBRATION (A). The HEADER CALIBRATION page appears.

### NOTE:

Unlock the mechanical float locks before calibrating the header.

20. Raise the header to the top of the feeder house range and ensure that both of the float indicators reach 0. Wait until the indicators stop moving before proceeding.
21. Lower the header until the float indicator reaches 4 and can go no further.
22. Raise the header again to the top of the feeder house range and ensure that both of the float indicators reach 0. Wait until the indicators stop moving before proceeding.
23. Select SAVE to confirm the calibration.
24. Select REEL AND CUTTERBAR POSITION CALIBRATION (A). The REEL AND CUTTERBAR POSITION CALIBRATION page appears.
25. Follow the instructions on the page. As you proceed through the calibration process, the display will automatically update to show the next step.
26. Select SAVE.
27. Press the X in the top right corner to exit the CALIBRATION & PROCEDURES page.

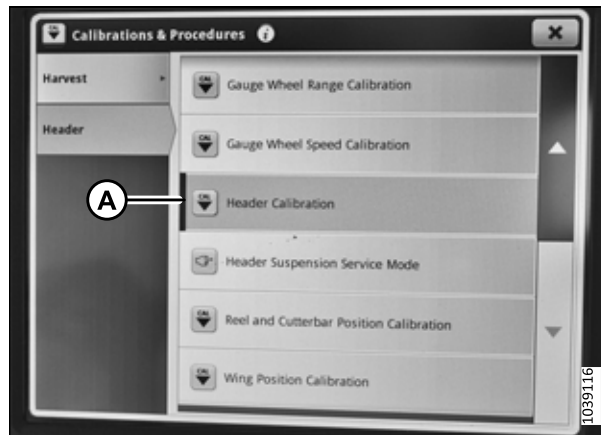


Figure 3.814: John Deere X9 Display – Header Calibration

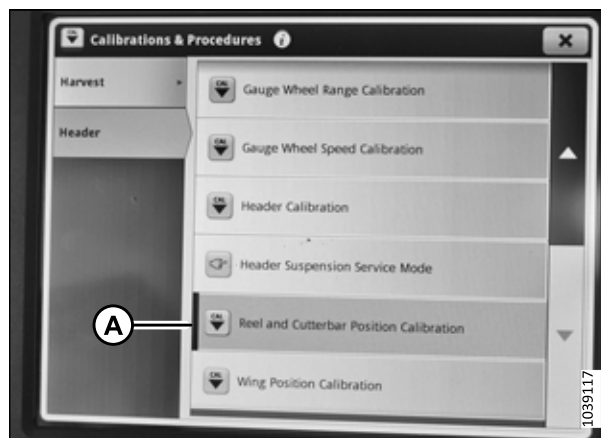


Figure 3.815: John Deere X9 Display – Reel and Cutterbar Position Calibration

### 3.18.3 Checking Voltage Range from Combine Cab – John Deere X9 Series

The voltage of the auto header height control (AHHC) sensors will need to be verified to ensure the proper operation of the system.

### NOTE:

Changes may have been made to the combine controls or the display since this document was published. For the most up-to-date information, refer to the combine operator's manual.

### DANGER

To prevent bodily injury or death from the unexpected start-up of the machine, always stop the engine and remove the key from the ignition before making adjustments to the machine.

### DANGER

Ensure that all bystanders have cleared the area.

## AUTO HEADER HEIGHT CONTROL SYSTEM

1. Position the header so that the cutterbar is 254–356 mm (10–14 in.) off the ground.
2. Shut down the engine, and remove the key from the ignition.
3. Unlock the header float. For instructions, refer to *Locking / Unlocking Header Float, page 221*.
4. Lock the header wings. For instructions, refer to *Operating in Rigid Mode, page 224*.

### CAUTION

To prevent cuts, pinches, and other bodily harm to the person checking the down stops, ensure that nobody is manually lifting, bouncing, or moving the header in any way while the down stop washer is being touched and checked for movement.

5. Ensure that the float lock linkage is on the down stops (washer [A] cannot move) at both locations.

#### NOTE:

If the header is **NOT** on the down stops, the voltage may go out of range during operation and cause the AHHC system to malfunction. To fix the problem, make the header heavier by decreasing the float. For instructions, refer to *Checking and Adjusting Header Float, page 210*.

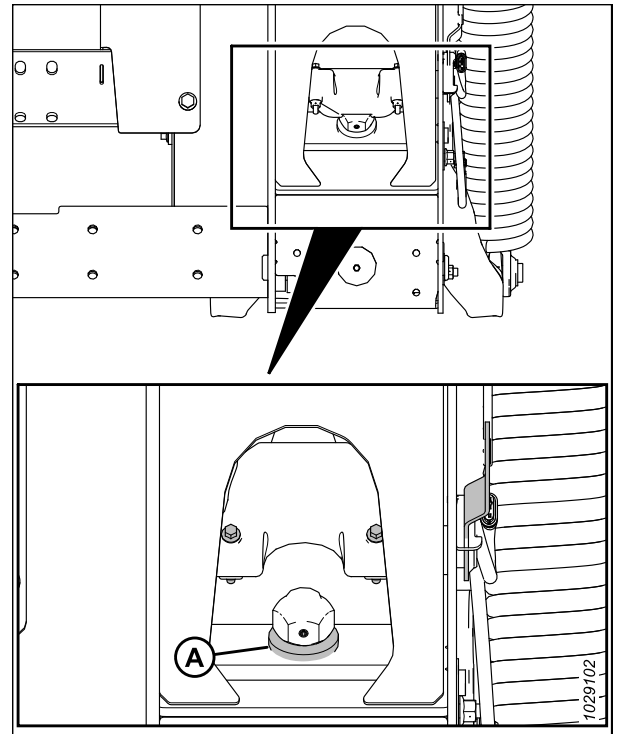


Figure 3.816: Down Stop Washer

6. If the pointer is not on zero, loosen bolt (A) and rotate float indicator plate (B) until pointer (C) is on 0 (D). Tighten the nut on bolt (A).

#### NOTE:

Use zero dot (E) above the decal to correctly set the indicator needle.

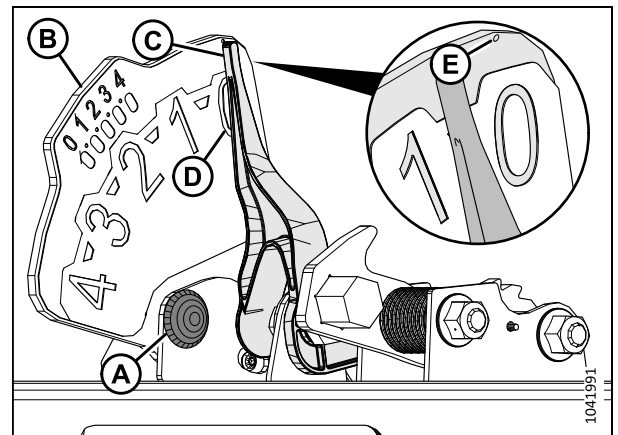


Figure 3.817: Float Indicator



## AUTO HEADER HEIGHT CONTROL SYSTEM

7. On the HARVESTING page, select MENU icon (A) in the bottom right corner of the page. The MENU appears.



Figure 3.818: John Deere X9 Display – Harvesting Page

8. Select SYSTEM tab (A), and then select DIAGNOSTICS CENTER (B).



Figure 3.819: John Deere X9 Display – System

9. Select CONTROLLERS tab (A).
10. Select HEADER/HITCH CONTROLLER (B).

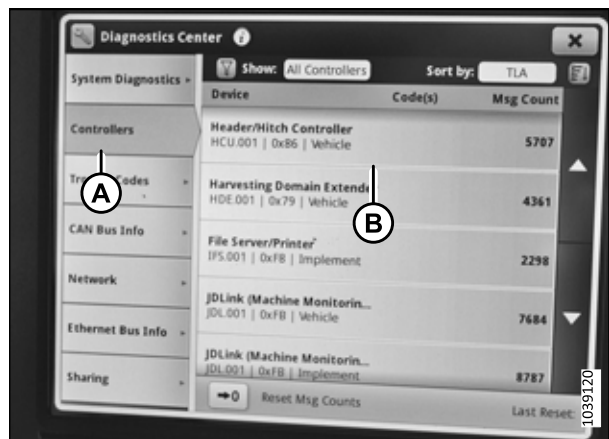


Figure 3.820: John Deere X9 Display – Diagnostics Center

## AUTO HEADER HEIGHT CONTROL SYSTEM

11. Select READINGS (A) on the display and scroll through list (B) to find the desired voltage reading. For information on the appropriate voltage range, refer to [3.2 Recommended Sensor Output Voltages for Combines, page 295](#).
12. Press the X in the top right corner to exit the HEADER/HITCH CONTROLLER page.
13. If the sensor voltage is not within the lower and upper limits, or if the range between the lower and upper limits is insufficient, refer to [3.3 Manually Checking Voltage Limits, page 296](#).

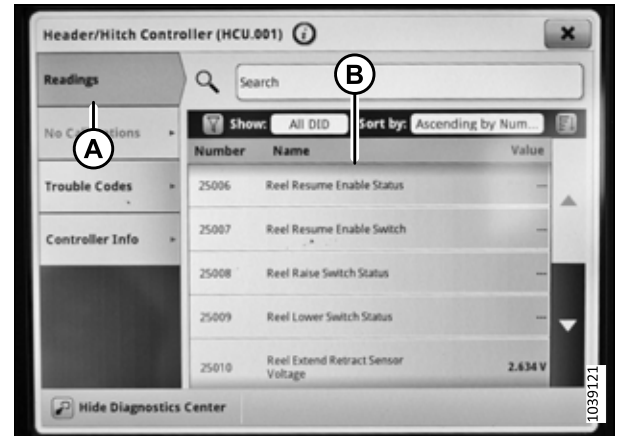


Figure 3.821: John Deere X9 Display – Header/Hitch Controller

### 3.18.4 Using Auto Header Height Control – John Deere X9 Series

The ground speed lever in the cab of the combine has three buttons which can be used to control the auto header height control (AHHC) system.

#### DANGER

Ensure that all bystanders have cleared the area.

#### NOTE:

Changes may have been made to the combine controls or the display since this document was published. For the most up-to-date information, refer to the combine operator's manual.

1. Start the engine.
2. Press HEADER button (A) on the panel below the display. The HEADER page opens.



Figure 3.822: CommandCenter™ Display

## AUTO HEADER HEIGHT CONTROL SYSTEM

3. Select AUTO CONTROL (A). The AUTO HEADER CONTROLS page opens.

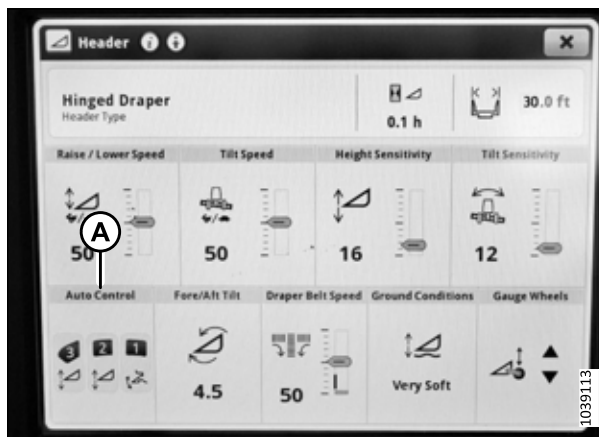


Figure 3.823: CommandCenter™ Display – Auto Header Controls Page

4. On the AUTO HEADER CONTROLS page, locate CONTROL PREVIEW (A).

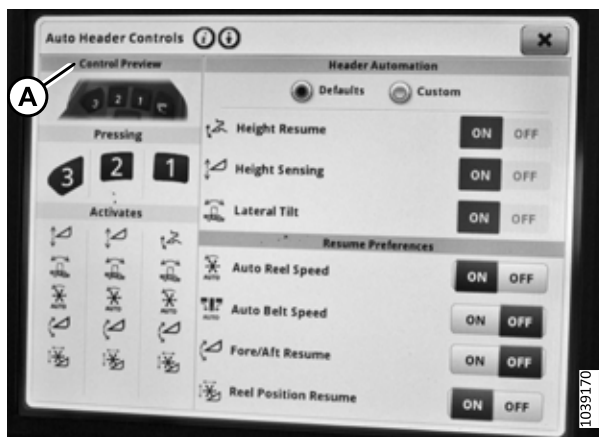


Figure 3.824: John Deere X9 Display – Auto Header Controls Page

### NOTE:

When buttons 2 or 3 (A) on the multifunction lever are pressed, the system automatically moves the header to the preset setting. The preset setting can be set by the Operator.

### NOTE:

Below each button on the display is a list of functions that the button will operate.

### NOTE:

Button 1 is used for the RETURN TO HEIGHT function.



Figure 3.825: John Deere X9 – Multifunction Lever

## AUTO HEADER HEIGHT CONTROL SYSTEM

- Press button 2 or 3 (B) on the multifunction lever to set the reel position.
- Press button (A) to adjust the reel fore-aft and reel height positions. Hold the button for 3 seconds to save the setting. This will become the preset reel setting for button 2 or 3.

**NOTE:**

Buttons 2 and 3 can have different settings.



Figure 3.826: John Deere X9 – Multifunction Lever

- If the header is equipped with the ContourMax™ option, the GAUGE WHEELS setting will need to be configured, depending on the desired cutting height. Proceed to the relevant topic:
  - [Cutting Above Ground Level – Headers Equipped with ContourMax™, page 493](#)
  - [Cutting at Ground Level – Headers Equipped with ContourMax™, page 495](#)

### *Cutting Above Ground Level – Headers Equipped with ContourMax™*

On John Deere X9 Series Combines, the auto header height control (AHC) system works only when cutting above ground level if the ContourMax™ option is installed on the header. The header float will need to be configured for headers cutting off of the ground which have the ContourMax™ option installed.

## DANGER

Ensure that all bystanders have cleared the area.

**NOTE:**

Changes may have been made to the combine controls or the display since this document was published. For the most up-to-date information, refer to the combine operator's manual.

- Start the engine.
- Press HEADER button (A) on the panel below the display. The HEADER page opens.



Figure 3.827: CommandCenter™ Display

## AUTO HEADER HEIGHT CONTROL SYSTEM

- On the HEADER page, select GAUGE WHEELS (A).

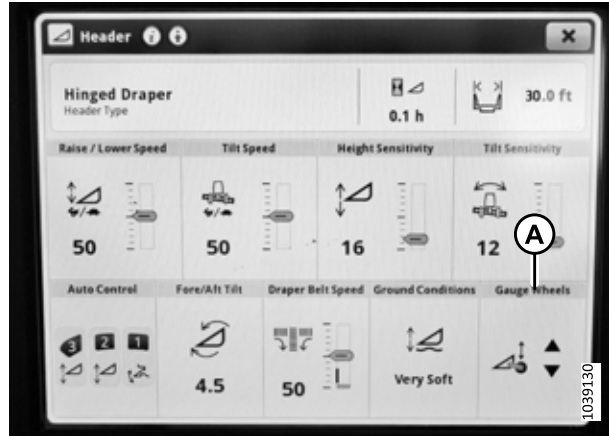


Figure 3.828: John Deere X9 Display – Header Page

- Adjust the height using the controls on the display or using dial (A) on the console. The setting will be saved automatically to multifunction lever button 2 or 3.



Figure 3.829: John Deere X9 Display – Header Page

- On the HEADER page, locate GROUND CONDITIONS (A).

**NOTE:**

This setting can be changed only when height sensing mode is enabled.

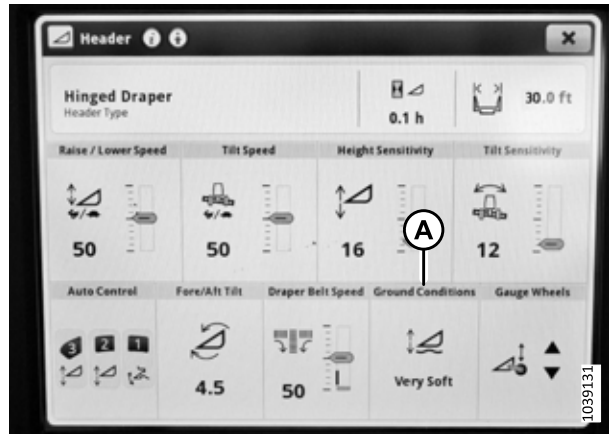


Figure 3.830: John Deere X9 Display – Header Page

## AUTO HEADER HEIGHT CONTROL SYSTEM

6. Choose one of the following header ground pressure settings:
  - VERY FIRM (1 on the float indicator)
  - FIRM (1.5 on the float indicator)
  - TYPICAL (2 on the float indicator)
  - SOFT (2.5 on the float indicator)
  - VERY SOFT (3 on the float indicator)

**NOTE:**

The firmer the setting, the more ground pressure is applied to the header.

**NOTE:**

These settings are automatically saved to button 2 or 3 on the multifunction handle, depending on which one is selected. The selected button is displayed on the corner display post.

### *Cutting at Ground Level – Headers Equipped with ContourMax™*

The header's auto header height control (AHC) system allows it to follow the contours of the ground during harvesting. If the header is equipped with the ContourMax™ option, the GAUGE WHEELS setting in the HEADER page on the CommandCenter™ in the combine cab will need to be adjusted.

### **DANGER**

Ensure that all bystanders have cleared the area.

**NOTE:**

Changes may have been made to the combine controls or the display since this document was published. For the most up-to-date information, refer to the combine operator's manual.

1. Start the engine.
2. Press HEADER button (A) on the panel below the display. The HEADER page opens.



Figure 3.831: CommandCenter™ Display



## AUTO HEADER HEIGHT CONTROL SYSTEM

3. On the HEADER page, select GAUGE WHEELS (A).

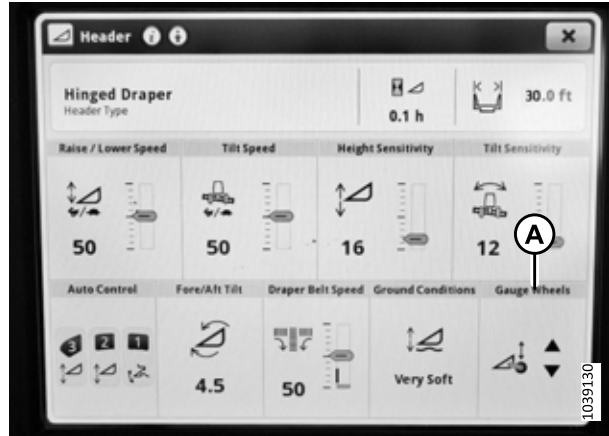


Figure 3.832: John Deere X9 Display – Header Page

4. Fully retract the wheels using the height adjustment on the display or use dial (A) on the console. The setting will be saved automatically to the active multifunction lever button (2 or 3).
5. Engage the header.



Figure 3.833: John Deere X9 Display – Header Page

6. On the HEADER page, locate GROUND CONDITIONS (A).

**NOTE:**

This setting can be changed only when sensing mode is enabled.

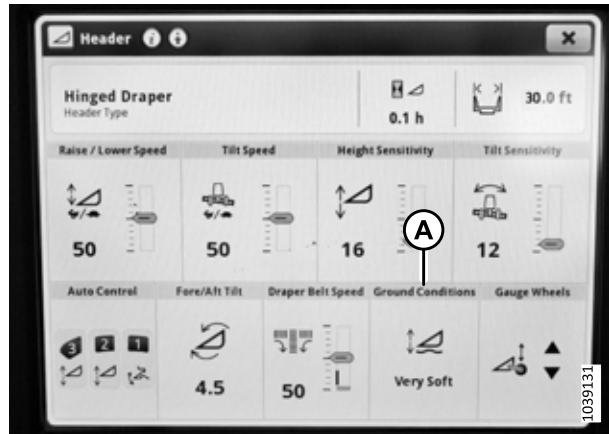


Figure 3.834: John Deere X9 Display – Header Page



## AUTO HEADER HEIGHT CONTROL SYSTEM

7. Choose one of the following header ground pressure settings:
  - VERY FIRM (1 on the float indicator)
  - FIRM (1.5 on the float indicator)
  - TYPICAL (2 on the float indicator)
  - SOFT (2.5 on the float indicator)
  - VERY SOFT (3 on the float indicator)

**NOTE:**

The firmer the setting, the more ground pressure is applied to the header.

**NOTE:**

These settings are automatically saved to button 2 or 3 on the multifunction handle, depending on which one is selected. The selected button is displayed on the corner display post.

### 3.18.5 Checking Error Codes on Header Controller – John Deere X9 Series

If errors occur while the auto header height control (AHHC) system is operating, the resulting error codes can be viewed in the combine computer's DIAGNOSTICS CENTER.

 **DANGER**

Ensure that all bystanders have cleared the area.

**NOTE:**

Changes may have been made to the combine controls or the display since this document was published. For the most up-to-date information, refer to the combine operator's manual.

1. Start the engine.
2. On the HARVESTING page, select MENU icon (A) in the bottom right corner of the page. The MENU appears.



Figure 3.835: John Deere X9 Display – Harvesting Page

## AUTO HEADER HEIGHT CONTROL SYSTEM

3. Select SYSTEM tab (A), and then select DIAGNOSTICS CENTER (B).



Figure 3.836: John Deere X9 Display – System

4. Select CONTROLLERS tab (A).
5. Select HEADER/HITCH CONTROLLER (B).

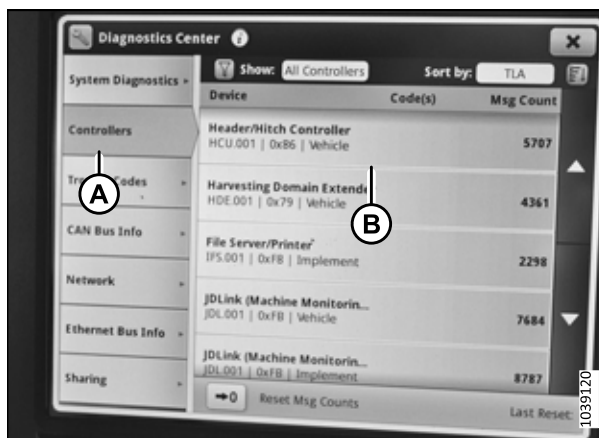


Figure 3.837: John Deere X9 Display – Diagnostics Center

6. Select TROUBLE CODES (A). Trouble codes appear on right side (B) of the display.
7. Press the X in the top right corner to exit the HEADER/HITCH CONTROLLER page.

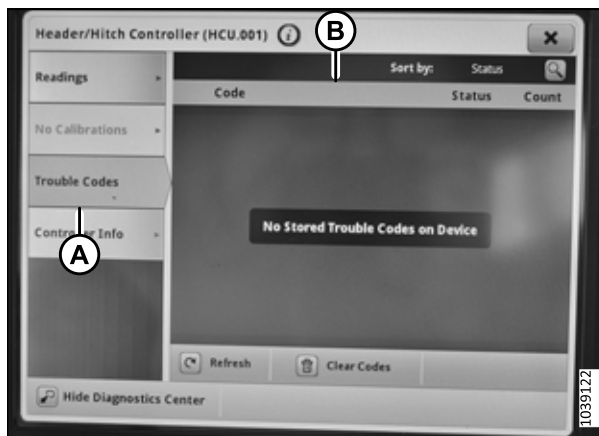


Figure 3.838: John Deere X9 Display – Header/Hitch Controller

### 3.18.6 Reel Reverse Function – John Deere X9 Series

You can allow the reel to reverse with the feeder house on the combine.

**⚠ DANGER**

Ensure that all bystanders have cleared the area.

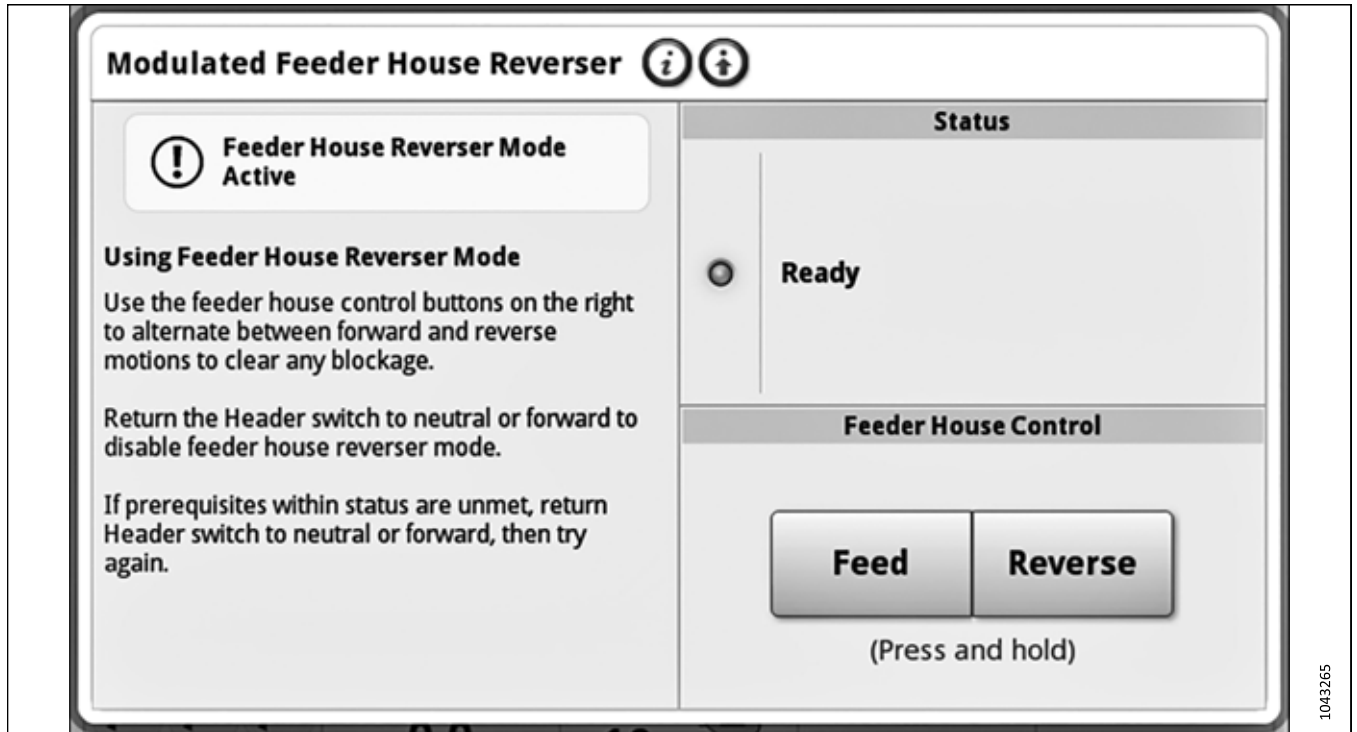


Figure 3.839: John Deere X9 Series Display

The reel can be operated in reverse using the feeder house reverser controls. For instructions and the most up-to-date information, refer to the combine operator’s manual.

**NOTE:**

The feeder house reverser controls can operate any float module from model year 2024 and later out-of-factory. Float modules from model year 2023 and prior require Reel Reverse Kit (B7543) before the feeder house reverser controls can be used.

## 3.19 New Holland CR and CX Series Combines – 2014 and Earlier

To make your header's auto header height control (AHHC) system compatible with the combine, you must set your combine's header configuration options for the particular model of header, configure the reel speed settings, set up the AHHC controls, and calibrate the AHHC system to ensure that it is working correctly.

### 3.19.1 Checking Voltage Range from Combine Cab – New Holland CR and CX Series

The auto header height control (AHHC) sensor needs to operate in a specific voltage range in order to work properly.

**NOTE:**

For New Holland CR models 6.80, 6.90, 7.90, 8.90, 9.90, and 10.90, refer to [3.20 New Holland Combines – CR Series \(2015 and Later\) and CH, page 513](#).

**NOTE:**

Changes may have been made to the combine controls or the display since this document was published. For the most up-to-date information, refer to the combine operator's manual.



**DANGER**

To prevent bodily injury or death from the unexpected start-up of the machine, always stop the engine and remove the key from the ignition before making adjustments to the machine.



**DANGER**

Ensure that all bystanders have cleared the area.

1. Position the header so that the cutterbar is 254–356 mm (10–14 in.) off the ground.
2. Shut down the engine, and remove the key from the ignition.
3. Unlock the header float. For instructions, refer to [Locking / Unlocking Header Float, page 221](#).
4. Lock the header wings. For instructions, refer to [Operating in Rigid Mode, page 224](#).

## AUTO HEADER HEIGHT CONTROL SYSTEM

### CAUTION

To prevent cuts, pinches, and other bodily harm to the person checking the down stops, ensure that nobody is manually lifting, bouncing, or moving the header in any way while the down stop washer is being touched and checked for movement.

5. Ensure that the float lock linkage is on the down stops (washer [A] cannot move) at both locations.

#### NOTE:

If the header is **NOT** on the down stops, the voltage may go out of range during operation and cause the AHHC system to malfunction. To fix the problem, make the header heavier by decreasing the float. For instructions, refer to [Checking and Adjusting Header Float, page 210](#).

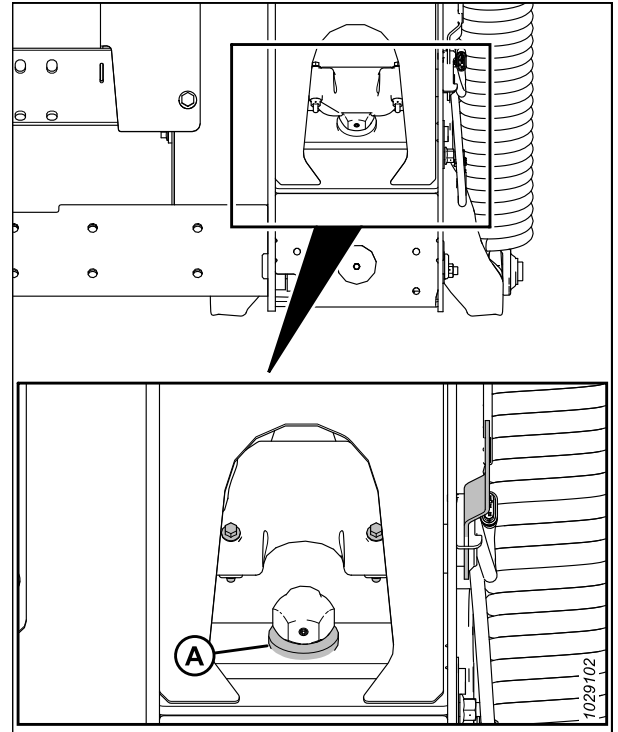


Figure 3.840: Down Stop Washer

6. If the pointer is not on zero, loosen bolt (A) and rotate float indicator plate (B) until pointer (C) is on 0 (D). Tighten the nut on bolt (A).

#### NOTE:

Use zero dot (E) above the decal to correctly set the indicator needle.

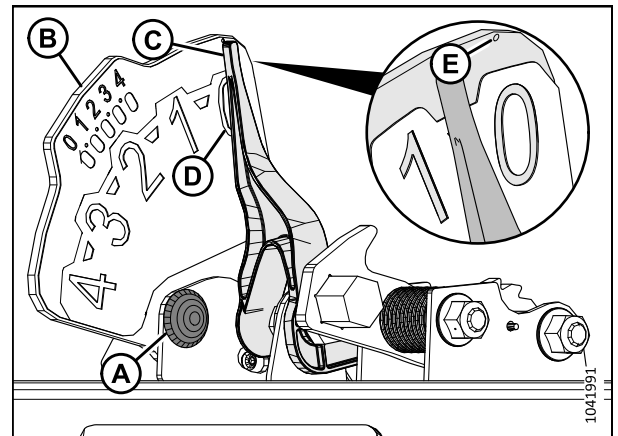


Figure 3.841: Float Indicator

## AUTO HEADER HEIGHT CONTROL SYSTEM

7. Ensure that the header float is unlocked.
8. Select DIAGNOSTICS (A) on the main page. The DIAGNOSTICS page appears.
9. Select SETTINGS. The SETTINGS page appears.

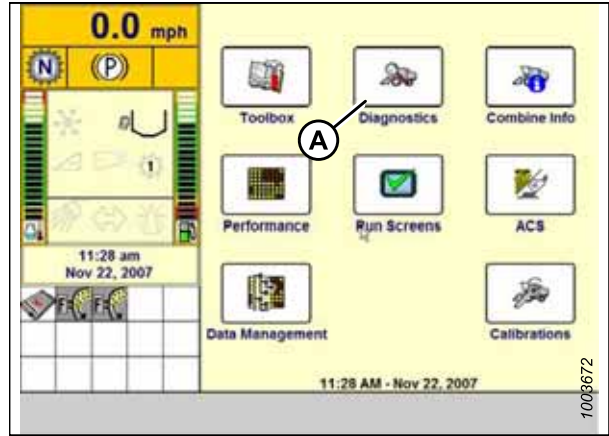


Figure 3.842: New Holland Combine Display

10. Select GROUP drop-down menu (A). The GROUP dialog box appears.

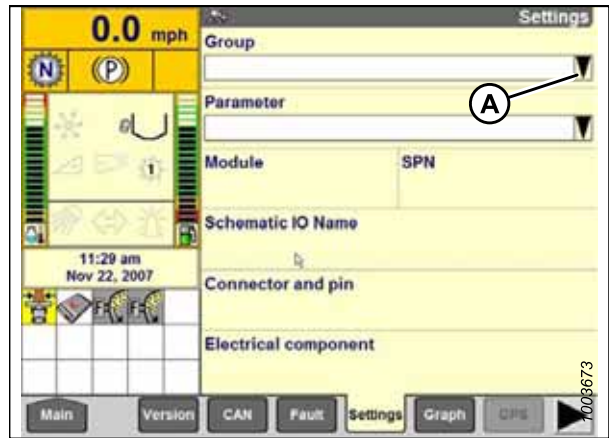


Figure 3.843: New Holland Combine Display

11. Select HEADER HEIGHT/TILT (A). The PARAMETER page appears.

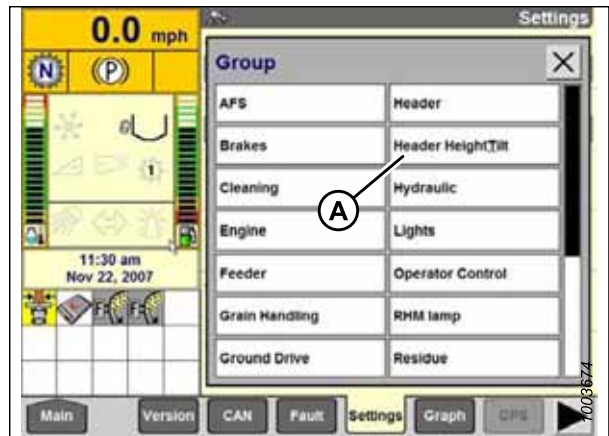


Figure 3.844: New Holland Combine Display

## AUTO HEADER HEIGHT CONTROL SYSTEM

12. Select LEFT HEADER HEIGHT SEN (A), then select GRAPH button (B). The voltage reading appears at the top of the page.
13. Raise and lower the header to see the full range of voltage readings.
14. Compare the voltage readings on the display to voltage ranges specified in [3.2 Recommended Sensor Output Voltages for Combines, page 295](#).
15. If the sensor voltage is not within the lower and upper limits, or if the range between the lower and upper limits is insufficient, refer to [3.3 Manually Checking Voltage Limits, page 296](#).

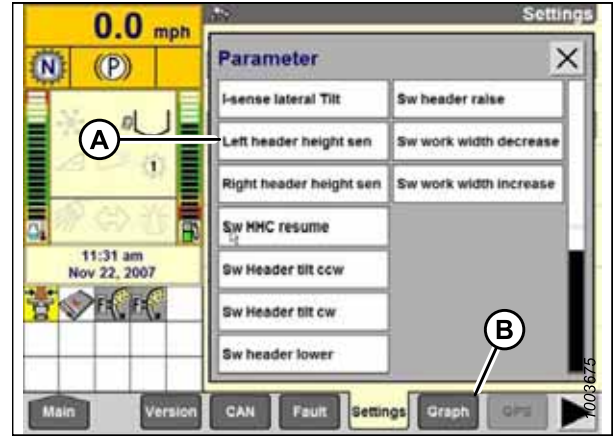


Figure 3.845: New Holland Combine Display

### 3.19.2 Header Settings Quick Reference – New Holland CR Series

Use the information in the following table to quickly reference the recommended settings for a header paired with a New Holland CR Series combine.

**NOTE:**

Changes may have been made to the combine controls or the display since this document was published. For the most up-to-date information, refer to the combine operator’s manual.

**Table 3.45 Header Settings – New Holland CR Series**

Setup Parameter	Suggested Setting
Cutting type	Platform
Header sub type	80/90
Autofloat	Installed
Auto header lift	Installed
Manual HHC raise/lower rate	Set for best performance
HHC height sensitivity	Set for best performance
HHC tilt sensitivity	Set for best performance
Reel height sensor	Yes

### 3.19.3 Setting up Auto Header Height Control – New Holland CR and CX Series

Use the combine display to set up the auto header height control (AHHC) system.

**NOTE:**

Changes may have been made to the combine controls or the display since this document was published. For the most up-to-date information, refer to the combine operator’s manual.

**NOTE:**

For New Holland CR models 6.80, 6.90, 7.90, 8.90, 9.90, and 10.90, refer to [3.20 New Holland Combines – CR Series \(2015 and Later\) and CH, page 513](#).



## AUTO HEADER HEIGHT CONTROL SYSTEM

1. Select HEADER LATERAL FLOAT on the combine display, and press ENTER.
2. Use the up and down navigation keys to select INSTALLED.



Figure 3.846: New Holland Combine Display

3. Select HEADER AUTOFLOAT, and press ENTER.
4. Use the up and down navigation keys to move between options, and select INSTALLED.



Figure 3.847: New Holland Combine Display

### 3.19.4 Calibrating Auto Header Height Control – New Holland CR and CX Series

The auto header height control (AHHC) sensor output must be calibrated for each combine.

#### NOTE:

For New Holland CR models 6.80, 6.90, 7.90, 8.90, 9.90, and 10.90, refer to [3.20 New Holland Combines – CR Series \(2015 and Later\) and CH, page 513](#).

#### DANGER

To prevent bodily injury or death from the unexpected start-up of the machine, always stop the engine and remove the key from the ignition before making adjustments to the machine.

#### DANGER

Ensure that all bystanders have cleared the area.

#### NOTE:

Changes may have been made to the combine controls or the display since this document was published. For the most up-to-date information, refer to the combine operator's manual.

## AUTO HEADER HEIGHT CONTROL SYSTEM

### NOTE:

If the header float is set too light, it can prevent the calibration of the AHHC. In order to prevent the header from separating from the float module, it may be necessary to change the float to a heavier setting during calibration.

1. Park the combine on a level surface.
2. Ensure that the header is level with the ground. If adjustment is required:
  - Ensure that the combine is parked on a level surface.
  - If equipped, use the combine's lateral tilt to level the feeder house with the ground.
  - If further adjustment is required, shut the engine off, remove the key from the ignition, and ensure that the combine's tires are inflated to the correct pressure.

### NOTE:

Spirit level (A) is located on top of the float module frame. The header is level if the bubble is in the center of the spirit level.

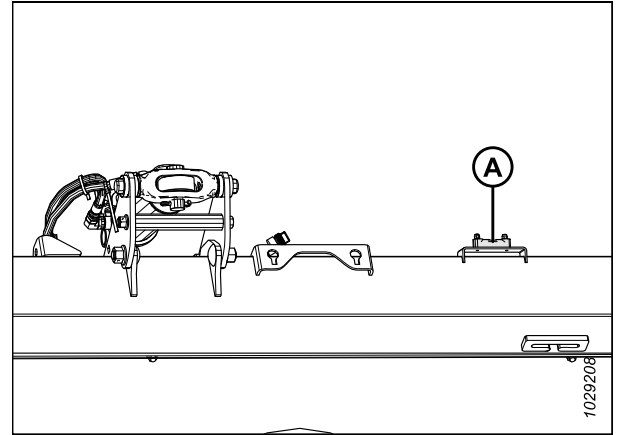


Figure 3.848: Spirit Level

3. Ensure that the center-link is set to **D**.

### NOTE:

When calibration is complete, adjust the center-link back to the desired header angle. For instructions, refer to [3.9.5 Header Angle, page 232](#).

4. Adjust the reel fore-aft position so that the indicator is at position **6**.
5. Position the header so that the cutterbar is 254–356 mm (10–14 in.) off the ground.
6. Shut down the engine, and remove the key from the ignition.

## AUTO HEADER HEIGHT CONTROL SYSTEM

### CAUTION

To prevent cuts, pinches, and other bodily harm to the person checking the down stops, ensure that nobody is manually lifting, bouncing, or moving the header in any way while the down stop washer is being touched and checked for movement.

7. Ensure that the float lock linkage is on the down stops (washer [A] cannot move) at both locations.

#### NOTE:

If the header is **NOT** on the down stops, the voltage may go out of range during operation and cause the AHHC system to malfunction. To fix the problem, make the header heavier by decreasing the float. For instructions, refer to [Checking and Adjusting Header Float, page 210](#).

8. Unlock the header float. For instructions, refer to [Locking / Unlocking Header Float, page 221](#).
9. Lock the header wings. For instructions, refer to [Operating in Rigid Mode, page 224](#).

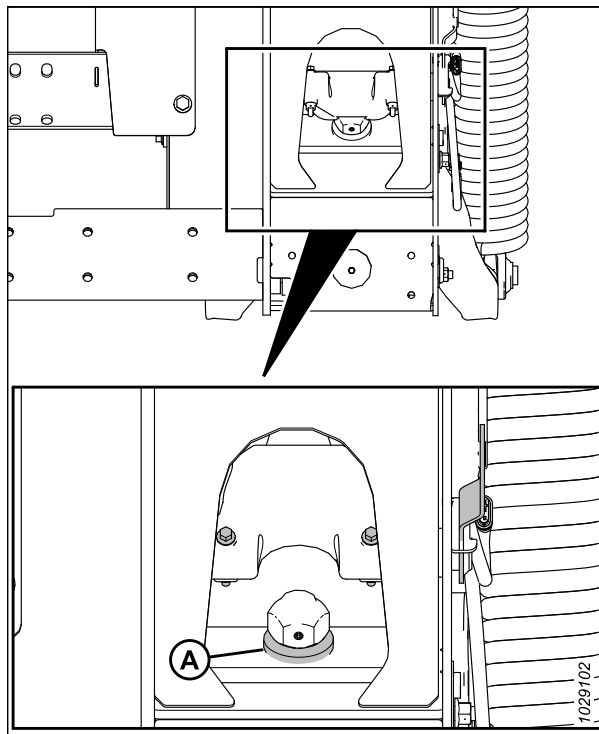


Figure 3.849: Down Stop Washer

**To calibrate the AHHC, follow these steps:**

10. Select CALIBRATION on the combine display, and press the RIGHT ARROW navigation key to enter the information box.
11. Select HEADER (A), and press ENTER. The CALIBRATION window opens.

#### NOTE:

You can use the up and down navigation keys to move between the options.



Figure 3.850: New Holland Combine Display

## AUTO HEADER HEIGHT CONTROL SYSTEM

12. Follow the steps in the order in which they appear in the window. As you proceed through the calibration process, the display will automatically update to show the next step.

**NOTE:**

Pressing the ESC key during any of the steps or letting the system sit idle for more than 3 minutes will stop the calibration procedure.

**NOTE:**

Refer to your combine operator's manual for an explanation of any error codes.



Figure 3.851: New Holland Combine Display

13. When all of the steps have been completed, a CALIBRATION SUCCESSFUL message will appear on the screen. Exit the CALIBRATION menu by pressing the ENTER or ESC key.

**NOTE:**

If the float was set heavier to complete the AHHC calibration procedure, adjust it to the recommended operating float after the calibration is complete.

14. If the unit does not function properly, conduct the maximum stubble height calibration. For instructions, refer to [3.19.5 Calibrating Maximum Stubble Height – New Holland CR and CX Series, page 507](#).

### 3.19.5 Calibrating Maximum Stubble Height – New Holland CR and CX Series

This procedure details how to set the height at which the harvest area counter will start and stop counting harvested area.

**NOTE:**

Changes may have been made to the combine controls or the display since this document was published. For the most up-to-date information, refer to the combine operator's manual.

**IMPORTANT:**

- If the value is set too low, the area counter may **NOT** be accurate since the header is sometimes raised above this threshold although the combine is still cutting.
- If the value is set too high, the area counter will keep counting even when the header is raised (but below this threshold) and the combine is no longer cutting crop.



**DANGER**

Ensure that all bystanders have cleared the area.

## AUTO HEADER HEIGHT CONTROL SYSTEM

1. Select the MAXIMUM STUBBLE HEIGHT calibration dialog box. As you proceed through the calibration process, the display automatically updates to show the next step.

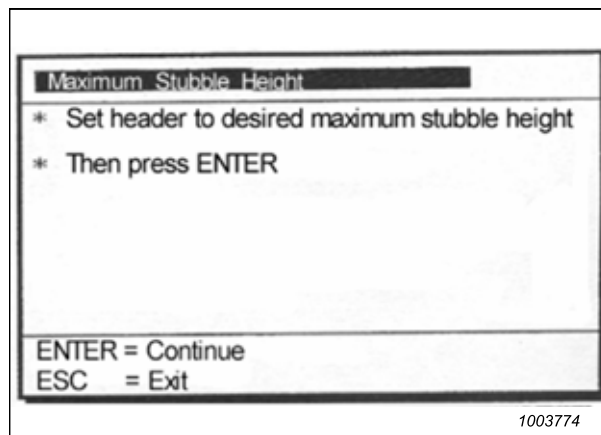


Figure 3.852: New Holland Calibration Dialog Box

2. Move the header to the desired maximum stubble height by using the control switch on the multifunction handle.
3. Press ENTER to continue. As you proceed through the calibration process, the display automatically updates to show the next step.
4. Press ENTER or ESC to close the calibration screen. The calibration is now complete.

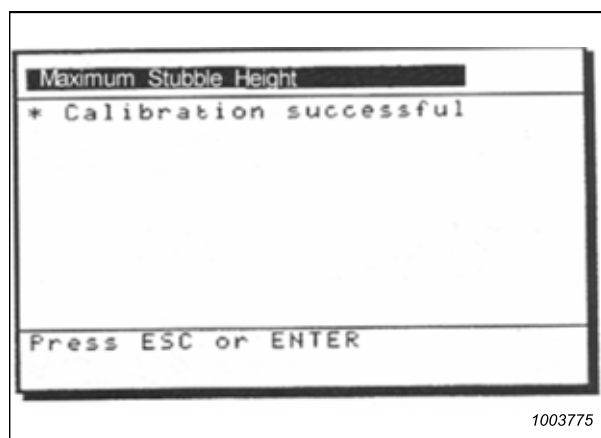


Figure 3.853: New Holland Calibration Dialog Box

### 3.19.6 Adjusting Header Raise Rate – New Holland CR and CX Series

If necessary, the header raise rate (the first speed on the HEADER HEIGHT rocker switch of the multifunction handle) can be adjusted.

#### NOTE:

Changes may have been made to the combine controls or the display since this document was published. For the most up-to-date information, refer to the combine operator's manual.

#### DANGER

Ensure that all bystanders have cleared the area.

#### NOTE:

For New Holland CR models 6.80, 6.90, 7.90, 8.90, 9.90, and 10.90, refer to [3.20 New Holland Combines – CR Series \(2015 and Later\)](#) and [CH, page 513](#).

## AUTO HEADER HEIGHT CONTROL SYSTEM

1. Select HEADER RAISE RATE on the combine display.
2. Use the + or – buttons to change the setting.
3. Press ENTER to save the new setting.

**NOTE:**

The raise rate can be changed from 32–236 in increments of 34. The factory setting is 100.

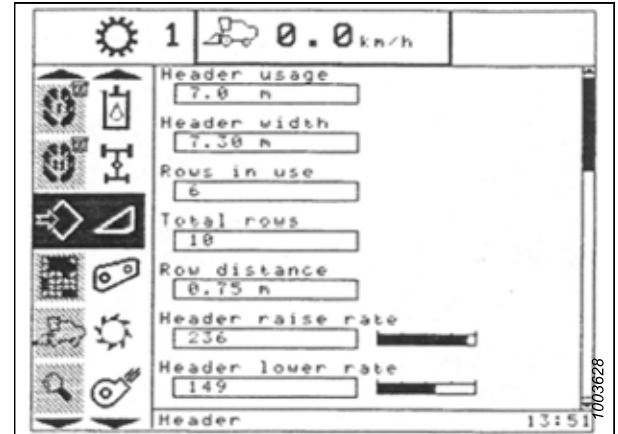


Figure 3.854: New Holland Combine Display

### 3.19.7 Adjusting Header Lower Rate – New Holland CR and CX Series

If necessary, the header lower rate (the automatic header height control button or second speed on the header height rocker switch of the multifunction handle) can be adjusted.

**NOTE:**

Changes may have been made to the combine controls or the display since this document was published. For the most up-to-date information, refer to the combine operator's manual.



### DANGER

Ensure that all bystanders have cleared the area.

**NOTE:**

For New Holland CR models 6.80, 6.90, 7.90, 8.90, 9.90, and 10.90, refer to [3.20 New Holland Combines – CR Series \(2015 and Later\) and CH, page 513](#).

1. Select HEADER LOWER RATE on the combine display.
2. Use the + or – buttons to change the setting to 50.
3. Press ENTER to save the new setting.

**NOTE:**

The header lower rate can be changed from 2–247 in increments of 7. It is factory-set to 100.

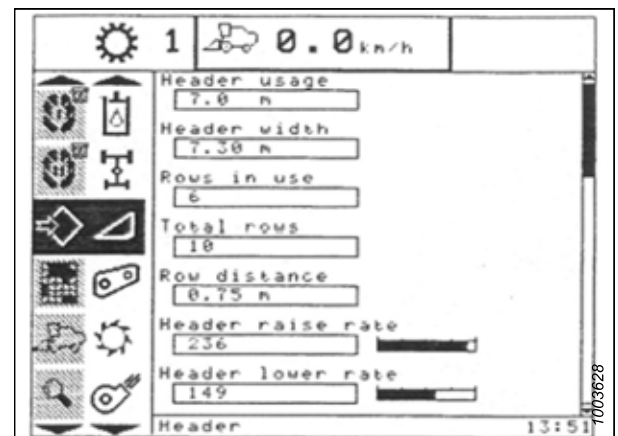


Figure 3.855: New Holland Combine Display

### 3.19.8 Setting Auto Header Height Control Sensitivity – New Holland CR and CX Series

The sensitivity adjustment controls the distance the cutterbar must travel up or down before the auto header height control (AHHC) reacts and raises or lowers the feeder house.

When the sensitivity is set to maximum, only small changes in ground height raise or lower the feeder house. When the sensitivity is set to minimum, large changes in the ground height are needed to raise or lower the feeder house.

**NOTE:**

Changes may have been made to the combine controls or the display since this document was published. For the most up-to-date information, refer to the combine operator’s manual.

**NOTE:**

For New Holland CR models 6.80, 6.90, 7.90, 8.90, 9.90, and 10.90, refer to [3.20 New Holland Combines – CR Series \(2015 and Later\) and CH, page 513](#).

**⚠ DANGER**

Ensure that all bystanders have cleared the area.

1. Engage the threshing mechanism and the feeder house.
2. Select HEIGHT SENSITIVITY on the combine display.
3. Use the + or – buttons to change the setting to 200.
4. Press ENTER to save the new setting.

**NOTE:**

The sensitivity can be changed from 10–250 in increments of 10. It is factory-set to 100.



Figure 3.856: New Holland Combine Display

### 3.19.9 Setting Preset Cutting Height – New Holland CR and CX Series

The reel and cut height setting can be stored in the combine’s computer as presets. These settings can be set and selected using the combine’s control console.

**NOTE:**

Changes may have been made to the combine controls or the display since this document was published. For the most up-to-date information, refer to the combine operator’s manual.

**NOTE:**

For New Holland CR models 6.80, 6.90, 7.90, 8.90, 9.90, and 10.90, refer to [3.20 New Holland Combines – CR Series \(2015 and Later\) and CH, page 513](#).



## AUTO HEADER HEIGHT CONTROL SYSTEM

### NOTE:

Indicator (A) should be at position 0 (B) with the header 254–356 mm (10–14 in.) off the ground. When the header is on the ground, the indicator should be at position 1 (C) for low ground pressure, and at position 4 (D) for high ground pressure. Crop and soil conditions determine the amount of float to use. The ideal setting is as light as possible without header bouncing or missing crop. Operating with heavy settings prematurely wears the cutterbar wearplates.

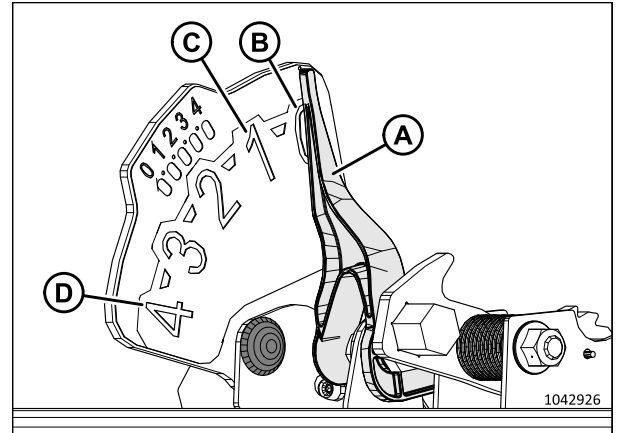


Figure 3.857: Float Indicator

1. Engage the threshing mechanism and the feeder house with switches (A) and (B).
2. Set HEADER MEMORY rocker switch (D) in STUBBLE HEIGHT/AUTOFLOAT mode position (A) or (B).
3. Raise or lower the header to the desired cutting height using HEADER HEIGHT momentary switch (C).
4. Lightly press AUTOMATIC HEADER HEIGHT CONTROL button (E) for a minimum of 2 seconds to store the height position. A beep confirms the setting.

### NOTE:

It is possible to store two different header height values by using HEADER MEMORY rocker switch (D) in STUBBLE HEIGHT/AUTOFLOAT mode position (A) or (B).

5. Raise or lower the reel to the desired working height using the REEL HEIGHT momentary switch.
6. Lightly press AUTOMATIC HEADER HEIGHT CONTROL button (E) for a minimum of 2 seconds to store the height position. A beep confirms the setting.

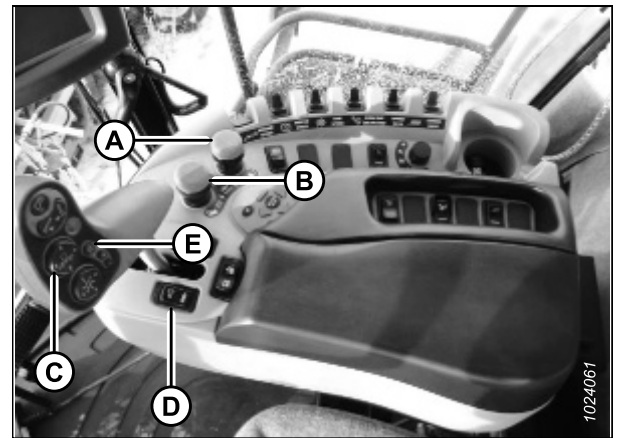


Figure 3.858: New Holland Combine Controls

## AUTO HEADER HEIGHT CONTROL SYSTEM

- To change one of the memorized header height set points while the combine is in use, use HEADER HEIGHT AND HEADER LATERAL FLOAT rocker switch (A) (slow up/down) to raise or lower header to the desired value. Lightly press AUTOMATIC HEADER HEIGHT CONTROL button (B) for a minimum of 2 seconds to store the new height position. A beep confirms setting.

**NOTE:**

Fully pressing AUTOMATIC HEADER HEIGHT CONTROL button (B) will disengage float mode.

**NOTE:**

It is not necessary to press rocker switch (C) again after changing header height set point.

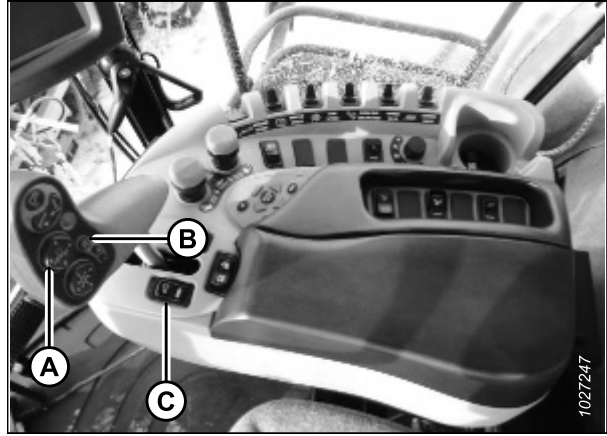


Figure 3.859: New Holland Combine Controls

## 3.20 New Holland Combines – CR Series (2015 and Later) and CH

To make your header's auto header height control (AHHC) system compatible with the combine, you must set your combine's header configuration options for the particular model of header, configure the reel speed settings, set up the AHHC controls, and calibrate the AHHC system to ensure that it is working correctly.

This section only applies to 2015 and later CR models (6.80, 6.90, 7.90, 8.90, 9.90, and 10.90).

### 3.20.1 Checking Voltage Range from Combine Cab – New Holland CR Series and CH

The auto header height control (AHHC) sensor needs to operate in a specific voltage range in order to work properly.

**NOTE:**

**CR Series:** This section applies only to 2015 and later CR models (6.80, 6.90, 7.90, 8.90, 9.90, and 10.90). For pre-2015 New Holland combine models, refer to [3.19 New Holland CR and CX Series Combines – 2014 and Earlier, page 500](#).

**NOTE:**

Changes may have been made to the combine controls or the display since this document was published. For the most up-to-date information, refer to the combine operator's manual.



**DANGER**

To prevent bodily injury or death from the unexpected start-up of the machine, always stop the engine and remove the key from the ignition before making adjustments to the machine.



**DANGER**

Ensure that all bystanders have cleared the area.

1. Position the header so that the cutterbar is 254–356 mm (10–14 in.) off the ground.
2. Shut down the engine, and remove the key from the ignition.
3. Unlock the header float. For instructions, refer to [Locking / Unlocking Header Float, page 221](#).
4. Lock the header wings. For instructions, refer to [Operating in Rigid Mode, page 224](#).

## AUTO HEADER HEIGHT CONTROL SYSTEM

### CAUTION

To prevent cuts, pinches, and other bodily harm to the person checking the down stops, ensure that nobody is manually lifting, bouncing, or moving the header in any way while the down stop washer is being touched and checked for movement.

5. Ensure that the float lock linkage is on the down stops (washer [A] cannot move) at both locations.

#### NOTE:

If the header is **NOT** on the down stops, the voltage may go out of range during operation and cause the AHHC system to malfunction. To fix the problem, make the header heavier by decreasing the float. For instructions, refer to [Checking and Adjusting Header Float, page 210](#).

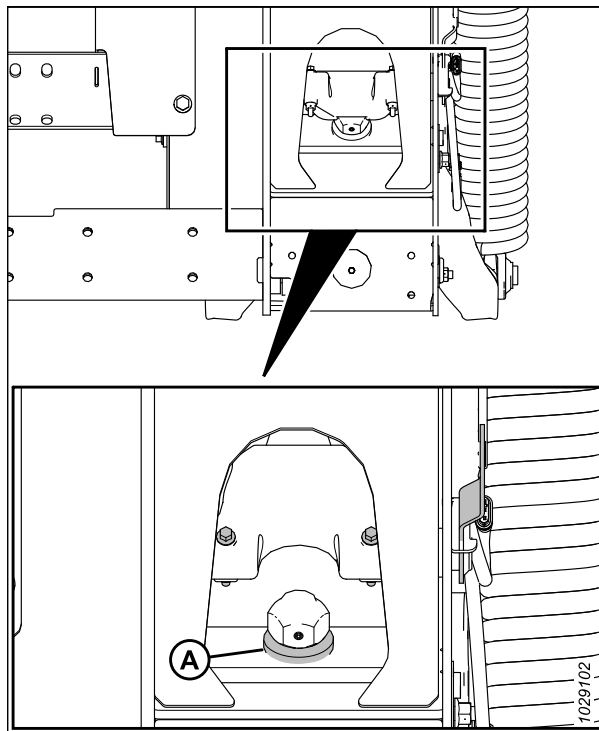


Figure 3.860: Down Stop Washer

6. If the pointer is not on zero, loosen bolt (A) and rotate float indicator plate (B) until pointer (C) is on 0 (D). Tighten the nut on bolt (A).

#### NOTE:

Use zero dot (E) above the decal to correctly set the indicator needle.

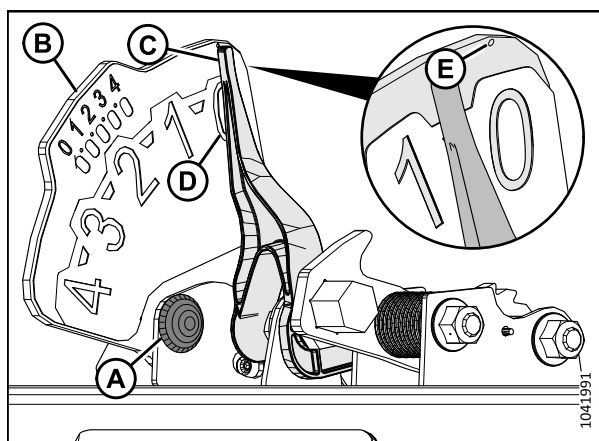


Figure 3.861: Float Indicator

## AUTO HEADER HEIGHT CONTROL SYSTEM

7. Select DIAGNOSTICS icon (A) on the main page. The DIAGNOSTICS page appears.



Figure 3.862: New Holland Combine Display

8. Select SETTINGS tab (A). The SETTINGS page appears.



Figure 3.863: New Holland Combine Display

9. Select HEADER HEIGHT/TILT (A) from the GROUP drop-down menu.
10. Select HEADER HEIGHT SENS. L (B) from the PARAMETER drop-down menu.

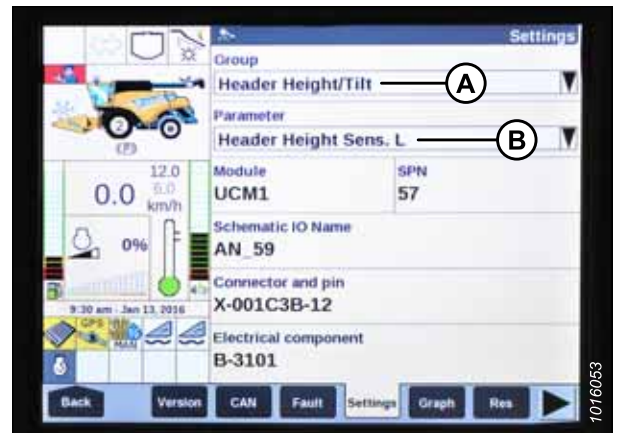


Figure 3.864: New Holland Combine Display

## AUTO HEADER HEIGHT CONTROL SYSTEM

11. Select GRAPH tab (A). The exact voltage (B) is displayed at the top of the page.
12. Raise and lower the header to see the full range of voltage readings.
13. If the sensor voltage is not within the lower and upper limits, or if the range between the lower and upper limits is insufficient, refer to [3.3 Manually Checking Voltage Limits](#), page 296.



Figure 3.865: New Holland Combine Display

### 3.20.2 Setting up Auto Header Height Control – New Holland CR Series and CH

Auto header height control (AHHC) is set up using the combine display and the control handle.

To ensure the best performance of the AHHC system, perform these procedures with the center-link set to **D**. When setup and calibration are complete, adjust the center-link back to the desired header angle.

#### NOTE:

Changes may have been made to the combine controls or the display since this document was published. For the most up-to-date information, refer to the combine operator's manual.

#### NOTE:

**CR models:** This section applies only to 2015 and later CR models (6.80, 6.90, 7.90, 8.90, 9.90, and 10.90). For other pre-2015 New Holland combine models, refer to [3.19 New Holland CR and CX Series Combines – 2014 and Earlier](#), page 500.

### DANGER

Ensure that all bystanders have cleared the area.

1. Ensure that the center-link is set to **D**.
2. Shut down the engine.
3. Turn the ignition key to the RUN position.

## AUTO HEADER HEIGHT CONTROL SYSTEM

4. Select TOOLBOX (A) on the main page. The TOOLBOX page appears.

### IMPORTANT:

Some New Holland combines will not allow you to change the header settings from the main menu. This is now a dealer setting. If you cannot change the header settings from the main menu, contact your Dealer.



Figure 3.866: New Holland Combine Display

5. Select HEAD 1 (A). The HEADER SETUP 1 page displays.
6. Select CUTTING TYPE drop-down arrow (B) and change the CUTTING TYPE to PLATFORM (C).

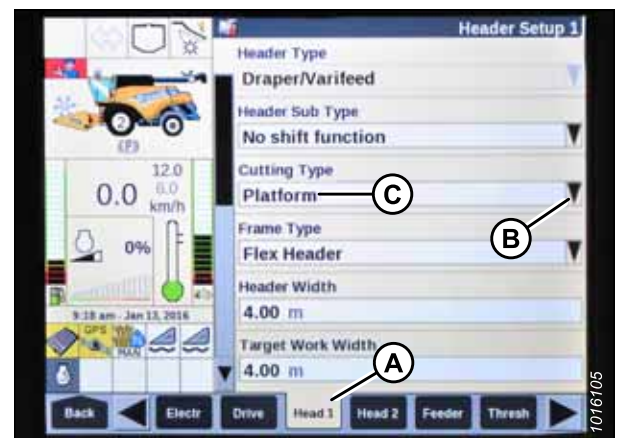


Figure 3.867: New Holland Combine Display

7. Select HEADER SUB TYPE drop-down arrow, and set HEADER SUB TYPE to 80/90 (A).



Figure 3.868: New Holland Combine Display



## AUTO HEADER HEIGHT CONTROL SYSTEM

8. Select HEAD 2 (A). The HEADER SETUP 2 page displays.



Figure 3.869: New Holland Combine Display

9. Select the AUTOFLOAT drop-down menu and set AUTOFLOAT to INSTALLED (A).
10. Select the AUTO HEADER LIFT drop-down menu and set AUTO HEADER LIFT to INSTALLED (B).

**NOTE:**

With AUTO HEADER LIFT installed and AHHC engaged, the header will lift up automatically when you pull back on the control handle.

11. Set the values for MANUAL HHC RAISE RATE (C) and MANUAL HHC LOWER RATE (D) for best performance according to ground conditions.



Figure 3.870: New Holland Combine Display

12. Set the values for HHC HEIGHT SENSITIVITY (A) and HHC TILT SENSITIVITY (B) for best performance according to ground conditions.



Figure 3.871: New Holland Combine Display

## AUTO HEADER HEIGHT CONTROL SYSTEM

- From REEL HEIGHT SENSOR menu (A), select YES.



Figure 3.872: New Holland Combine Display

### 3.20.3 Setting up Reel Speed – New Holland CR Series and CH

The reel diameter and the reel displacement settings will need to be entered into the combine's computer before the reel can be operated.

**NOTE:**

Changes may have been made to the combine controls or the display since this document was published. For the most up-to-date information, refer to the combine operator's manual.

**NOTE:**

**CR models:** This section applies only to 2015 and later CR models (6.80, 6.90, 7.90, 8.90, 9.90, and 10.90). For other pre-2015 New Holland combine models, refer to [3.19 New Holland CR and CX Series Combines – 2014 and Earlier, page 500](#).

- Shut down the engine.
- Turn the ignition key to the RUN position.
- Ensure that the combine display software is updated to the relevant version specified below or later:
  - Combines from model years 2015–2018: UCM v38.10.0.0
  - Combines from model year 2019 or later: UCM v1.4.0.0
- Ensure that the center-link is set to **D**.
- Select TOOLBOX (A) on the main page. The TOOLBOX page appears.

**IMPORTANT:**

Some New Holland combines will not allow you to change the header settings from the main menu. This is now a dealer setting. If you cannot change the header settings from the main menu, contact your Dealer.

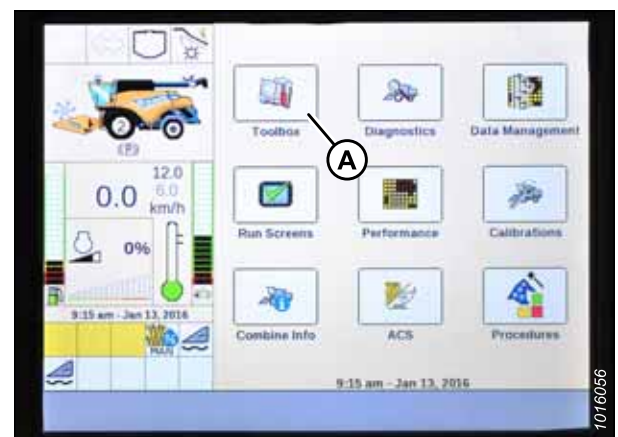


Figure 3.873: New Holland Combine Display

## AUTO HEADER HEIGHT CONTROL SYSTEM

6. Select HEAD 2 (A). The HEADER SETUP 2 page appears.
7. Select REEL DIAMETER (B) and enter 102 cm (40.16 in).
8. Select REEL DISPLACEMENT PER REVOLUTION (C) and enter the appropriate value according to the specific combination of drive and driven sprocket sizes detailed in Table 3.46, page 520.

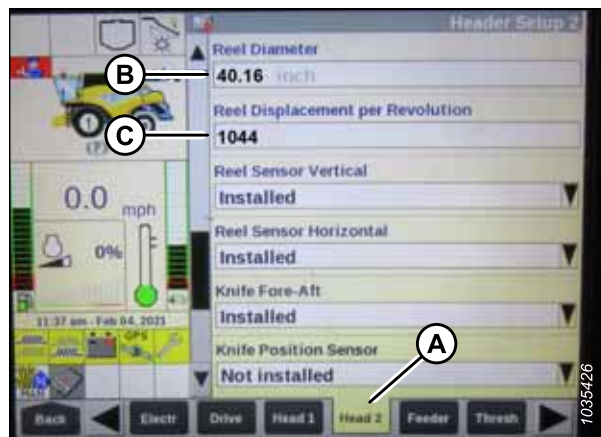


Figure 3.874: New Holland Combine Display

Table 3.46 Reel Displacement per Revolution Chart

Drive Sprocket Size (Number of Teeth)	Driven Sprocket Size (Number of Teeth)	Reel Displacement Per Revolution
19 (standard)	56	769
14 (high torque / low speed) <sup>82</sup>	56	1044
20 (low torque / high speed) <sup>83</sup>	52	679

### 3.20.4 Calibrating Auto Header Height Control – New Holland CR Series and CH

The auto header height control (AHHC) sensor output must be calibrated for each combine, or the AHHC feature will not work properly.

**NOTE:**

**CR models:** This section applies only to 2015 and later CR models (6.80, 6.90, 7.90, 8.90, 9.90, and 10.90). For other pre-2015 New Holland combine models, refer to [3.19 New Holland CR and CX Series Combines – 2014 and Earlier, page 500](#).

**! DANGER**

To prevent bodily injury or death from the unexpected start-up of the machine, always stop the engine and remove the key from the ignition before making adjustments to the machine.

**! DANGER**

Ensure that all bystanders have cleared the area.

**NOTE:**

Changes may have been made to the combine controls or the display since this document was published. For the most up-to-date information, refer to the combine operator's manual.

**NOTE:**

If the header float is set too light, it can prevent the calibration of the AHHC. In order to prevent the header from separating from the float module, it may be necessary to change the float to a heavier setting during calibration.

82. Two speed kit with chain on inner sprockets.

83. Two speed kit with chain on outer sprockets.

## AUTO HEADER HEIGHT CONTROL SYSTEM

1. Park the combine on a level surface.
2. Ensure that the header is level with the ground. If adjustment is required:
  - Ensure that the combine is parked on a level surface.
  - If equipped, use the combine's lateral tilt to level the feeder house with the ground.
  - If further adjustment is required, shut the engine off, remove the key from the ignition, and ensure that the combine's tires are inflated to the correct pressure.

**NOTE:**

Spirit level (A) is located on top of the float module frame. The header is level if the bubble is in the center of the spirit level.

3. Ensure that the center-link is set to **D**.

**NOTE:**

When calibration is complete, adjust the center-link back to the desired header angle. For instructions, refer to [3.9.5 Header Angle, page 232](#).

4. Adjust the reel fore-aft position so that the indicator is at position **6**.
5. Position the header so that the cutterbar is 254–356 mm (10–14 in.) off the ground.
6. Shut down the engine, and remove the key from the ignition.

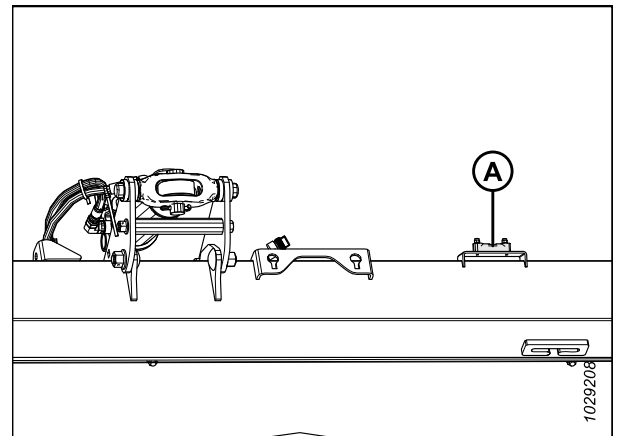


Figure 3.875: Spirit Level

## AUTO HEADER HEIGHT CONTROL SYSTEM

### CAUTION

To prevent cuts, pinches, and other bodily harm to the person checking the down stops, ensure that nobody is manually lifting, bouncing, or moving the header in any way while the down stop washer is being touched and checked for movement.

7. Ensure that the float lock linkage is on the down stops (washer [A] cannot move) at both locations.

#### NOTE:

If the header is **NOT** on the down stops, the voltage may go out of range during operation and cause the AHHC system to malfunction. To fix the problem, make the header heavier by decreasing the float. For instructions, refer to [Checking and Adjusting Header Float, page 210](#).

8. Unlock the header float. For instructions, refer to [Locking / Unlocking Header Float, page 221](#).
9. Lock the header wings. For instructions, refer to [Operating in Rigid Mode, page 224](#).

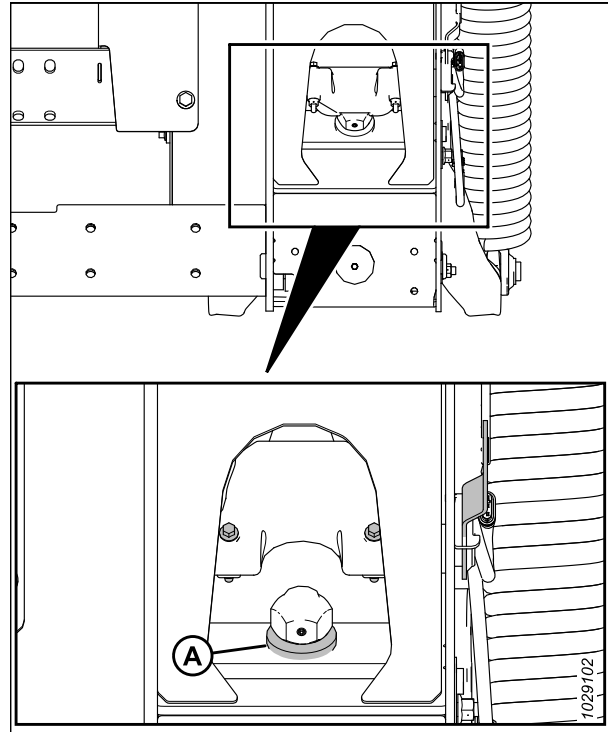


Figure 3.876: Down Stop Washer

To calibrate the AHHC, follow these steps:

10. Select CALIBRATIONS (A) on the main page. The CALIBRATION page appears.

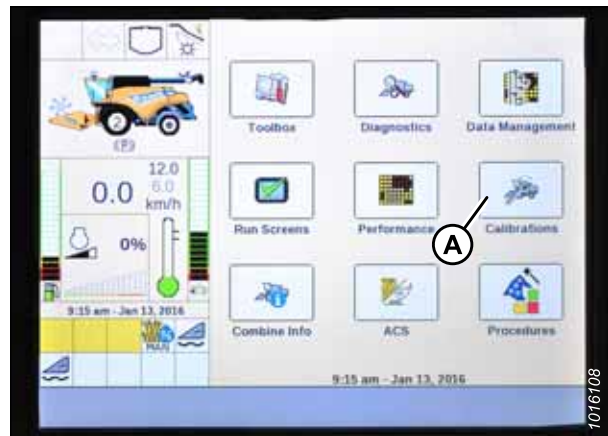


Figure 3.877: New Holland Combine Display

## AUTO HEADER HEIGHT CONTROL SYSTEM

11. Select CALIBRATION drop-down menu (A).



Figure 3.878: New Holland Combine Display

12. Select HEADER (A) from the list of calibration options.



Figure 3.879: New Holland Combine Display

13. Follow the calibration steps in the order in which they appear on the page. As you proceed through the calibration process, the display updates to show the next step.

**NOTE:**

Pressing the ESC key during any of the steps or letting the system sit idle for more than 3 minutes stops the calibration procedure.

**NOTE:**

Refer to your combine operator's manual for an explanation of any error codes.



Figure 3.880: New Holland Combine Display



## AUTO HEADER HEIGHT CONTROL SYSTEM

- When all steps have been completed, the CALIBRATION COMPLETED message appears on the page.

### NOTE:

If the float was set heavier to complete AHHC calibration procedure, adjust it to the recommended operating float after the calibration is complete.



Figure 3.881: New Holland Combine Display

### 3.20.5 Calibrating Reel Height Sensor and Reel Fore-Aft Sensor – New Holland CR Series and CH

The reel height sensor and reel fore-aft sensor will need to be calibrated before the auto header height control (AHHC) system can be used. Calibrating the reel position calibrates the reel height sensor and the reel fore-aft sensor.

### DANGER

Ensure that all bystanders have cleared the area.

### NOTE:

Changes may have been made to the combine controls or the display since this document was published. For the most up-to-date information, refer to the combine operator's manual.

### NOTE:

**CR models:** This section applies only to 2015 and later CR models (6.80, 6.90, 7.90, 8.90, 9.90, and 10.90). For other pre-2015 New Holland combine models, refer to [3.19 New Holland CR and CX Series Combines – 2014 and Earlier, page 500](#).

To calibrate the reel position, follow these steps:

- Start the engine.
- Position the header 254–356 mm (10–14 in.) off the ground.

### IMPORTANT:

Do **NOT** turn off the engine. The combine must be at a full idle to properly calibrate the sensors.



## AUTO HEADER HEIGHT CONTROL SYSTEM

3. Select CALIBRATIONS (A) on the main page.  
The CALIBRATION page appears.



Figure 3.882: New Holland Combine Display

4. Select CALIBRATION drop-down menu (A).



Figure 3.883: New Holland Combine Display

5. Select REEL POSITION (A) from the list of calibration options.

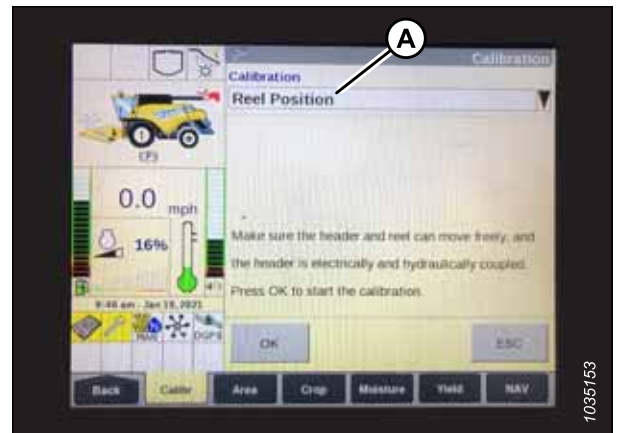


Figure 3.884: New Holland Combine Display

## AUTO HEADER HEIGHT CONTROL SYSTEM

6. CAUTION statement (A) appears. Select ENTER.

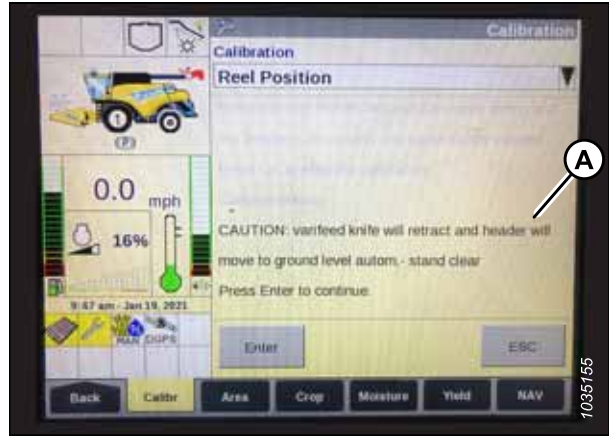


Figure 3.885: New Holland Combine Display

7. If the statement “Confirm varifeed knife is completely retracted” (A) appears, select ENTER.

**NOTE:**

The varifeed knife is not applicable to MacDon headers.

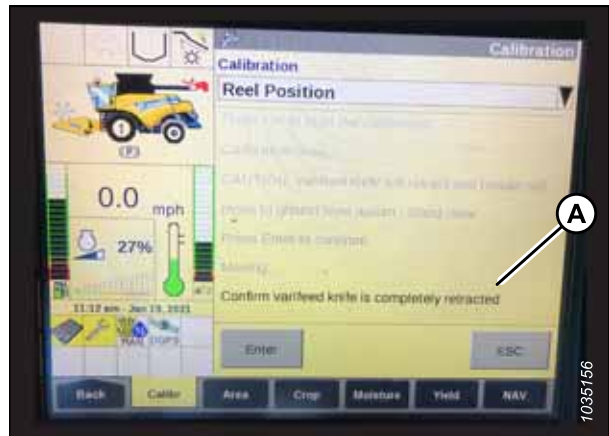


Figure 3.886: New Holland Combine Display

8. Follow calibration steps (A) as they appear on the page. As you proceed through the calibration process, the display automatically updates to show the next step.

**NOTE:**

Pressing the ESC key during any of the steps or letting the system sit idle for more than 3 minutes will stop the calibration procedure.

**NOTE:**

Refer to your combine operator’s manual for an explanation of any error codes.

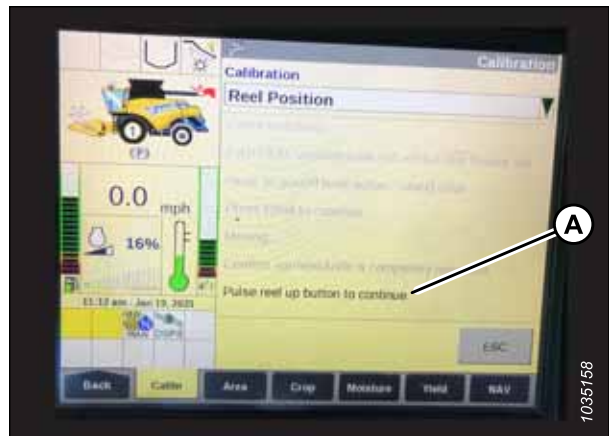


Figure 3.887: New Holland Combine Display

### 3.20.6 Checking Reel Height Sensor Voltages – New Holland CR Series and CH

Check the reel height sensor voltages to ensure that they are within the required range.

**NOTE:**

Changes may have been made to the combine controls or the display since this document was published. For the most up-to-date information, refer to the combine operator’s manual.

1. On the main page of the combine display, select DIAGNOSTICS (A). The DIAGNOSTICS page appears.



Figure 3.888: New Holland Combine Display

2. Select SETTINGS tab (A). The SETTINGS page appears.
3. From GROUP menu (B), select HEADER.
4. From PARAMETER menu (C), select REEL VERTICAL POSITION.

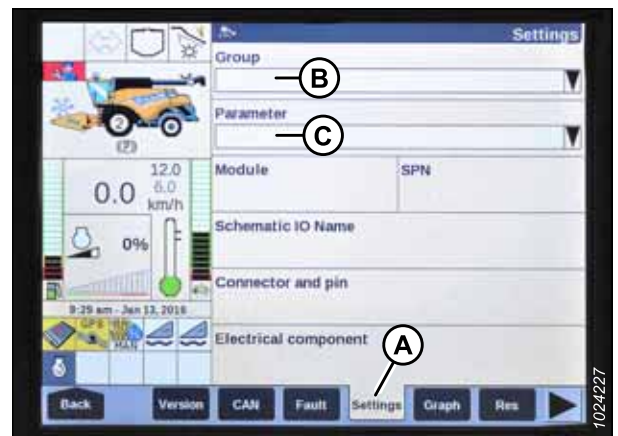


Figure 3.889: New Holland Combine Display

## AUTO HEADER HEIGHT CONTROL SYSTEM

5. Select GRAPH tab (A). The REEL VERTICAL POSITION graph displays.
6. Raise the reel to view low voltage (C). The voltage should be within 0.7–1.1 V.
7. Lower the reel to view high voltage (B). The voltage should be within 3.9–4.3 V.
8. If either voltage is out of range, refer to *Checking and Adjusting Reel Height Sensor*, page 248.

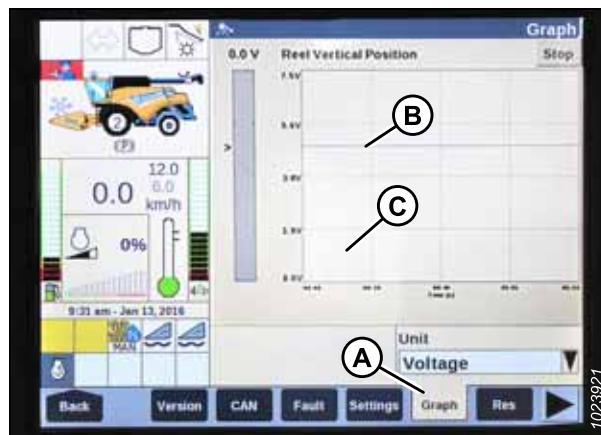


Figure 3.890: New Holland Combine Display

### 3.20.7 Setting Preset Cutting Height – New Holland CR Series and CH

The cut height setting can be stored in the combine. When harvesting, the setting can be selected from the control handle.

#### NOTE:

Changes may have been made to the combine controls or the display since this document was published. For the most up-to-date information, refer to the combine operator's manual.

#### NOTE:

**CR models:** This section applies only to 2015 and later CR models (6.80, 6.90, 7.90, 8.90, 9.90, and 10.90). For other pre-2015 New Holland combine models, refer to *3.19 New Holland CR and CX Series Combines – 2014 and Earlier*, page 500.

The console has two buttons used for auto height presets. The toggle switch that was present on previous models is now configured as shown at right. MacDon headers only require first two buttons (A) and (B). Third button (C) is not configured.



Figure 3.891: New Holland Combine Controls

To set a preset cutting height, follow these steps:

#### DANGER

Ensure that all bystanders have cleared the area.

## AUTO HEADER HEIGHT CONTROL SYSTEM

1. Engage the separator and the header.
2. Press preset button 1 (A). A yellow light on the button lights up.
3. Move the header to the desired cutting height.



Figure 3.892: New Holland Combine Controls

4. To set the preset, hold RESUME button (C) on the multifunction handle until the monitor beeps.

**NOTE:**

When setting presets, always set the header position before setting the reel position. If the header and the reel are set at the same time, the reel setting will not save.

5. Move the reel to the desired working position.
6. Hold RESUME button (C) on the multifunction handle to set the preset.
7. Repeat Step 2, [page 529](#) to Step 6, [page 529](#), using preset button 2.



Figure 3.893: New Holland Combine Multifunction Handle

8. Lower the header to the ground.
9. Select RUN SCREENS (A) on the main page.



Figure 3.894: New Holland Combine Display



## AUTO HEADER HEIGHT CONTROL SYSTEM

10. Select the RUN tab that shows MANUAL HEIGHT.

**NOTE:**

The MANUAL HEIGHT field may appear on any of the RUN tabs. When an auto height preset button is pressed, the display changes to AUTO HEIGHT (A).

11. Press one of the auto height preset buttons to select a preset cutting height.



Figure 3.895: New Holland Combine Display

### 3.20.8 Setting Maximum Work Height – New Holland CR Series and CH

The maximum work height can be set using the combine display.

**NOTE:**

Changes may have been made to the combine controls or the display since this document was published. For the most up-to-date information, refer to the combine operator's manual.

**NOTE:**

**CR models:** This section applies only to 2015 and later CR models (6.80, 6.90, 7.90, 8.90, 9.90, and 10.90). For other pre-2015 New Holland combine models, refer to [3.19 New Holland CR and CX Series Combines – 2014 and Earlier, page 500](#).

1. Select TOOLBOX (A) on the main page. The TOOLBOX page appears.

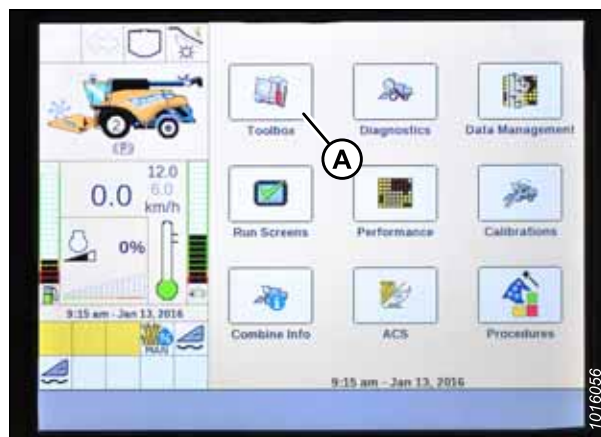


Figure 3.896: New Holland Combine Display

## AUTO HEADER HEIGHT CONTROL SYSTEM

2. Select FEEDER (A). The FEEDER SETUP page appears.
3. Select MAXIMUM WORK HEIGHT field (B).

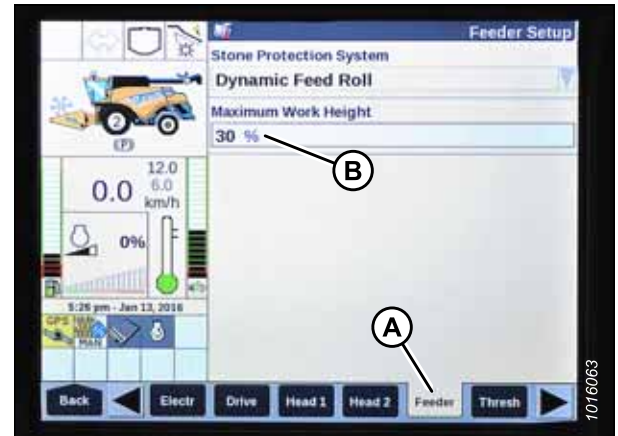


Figure 3.897: New Holland Combine Display

4. Set MAXIMUM WORK HEIGHT to the desired value.
5. Select SET and then press ENTER.



Figure 3.898: New Holland Combine Display

### 3.20.9 Configuring Reel Fore-Aft, Header Tilt, and Header Type – New Holland CR Series and CH

The reel fore-aft, header tilt, and header type settings for the auto header height control (AHHC) system can be changed by accessing the HEAD menus.

#### NOTE:

**CR models:** This procedure applies only to 2016 New Holland CR models 6.90, 7.90, 8.90, and 9.90.

#### NOTE:

Changes may have been made to the combine controls or the display since this document was published. For the most up-to-date information, refer to the combine operator's manual.

#### NOTE:

Some New Holland combines will not allow you to change the header settings from the main menu. This is now a dealer setting. If you cannot change the header settings from the main menu, contact your Dealer.

### DANGER

Ensure that all bystanders have cleared the area.

1. Turn the ignition key to the RUN position.



## AUTO HEADER HEIGHT CONTROL SYSTEM

- On the HEAD 1 page, change CUTTING TYPE (A) from FLEX to PLATFORM.



Figure 3.899: New Holland Combine Display

- On the HEAD 2 page, change HEADER SUB TYPE (A) from DEFAULT to 80/90.



Figure 3.900: New Holland Combine Display

There are now two different buttons for the ON GROUND presets. The toggle switch that was present on previous models is now configured as shown at right. MacDon headers only require first two buttons (A) and (B). Third button down (C) is not configured.



Figure 3.901: New Holland Combine Controls

### 3.20.10 Reel Reverse Function – New Holland CR Series and CH

You can allow the reel to reverse with the feeder house on New Holland CR Series and CH combines.

**⚠ DANGER**

Ensure that all bystanders have cleared the area.

**NOTE:**

Changes may have been made to the combine controls or the display since this document was published. For the most up-to-date information, refer to the combine operator’s manual.

1. Select TOOLBOX (A) on the MAIN page.



Figure 3.902: New Holland Combine Display

2. Select HEAD 1 tab (A).

**NOTE:**

To locate the HEAD 1 tab, you may need to use side arrows (B).

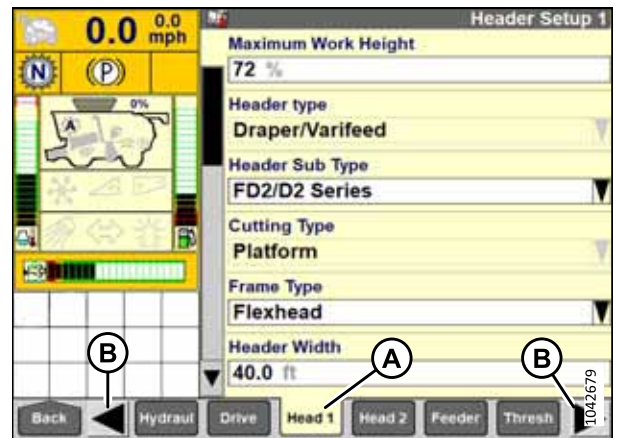


Figure 3.903: New Holland Combine Display

## AUTO HEADER HEIGHT CONTROL SYSTEM

3. Locate the HEADER SUB TYPE field.
4. Select the following value from the HEADER SUB TYPE window:
  - If software version 36.4.X.X or later is installed, select FD2/D2 SERIES (A).

**NOTE:**

Selecting FD2/D2 SERIES will optimize AHHC performance on FD2 Series FlexDraper® Headers.

- If software version prior to 36.4.X.X is installed, select 80/90.

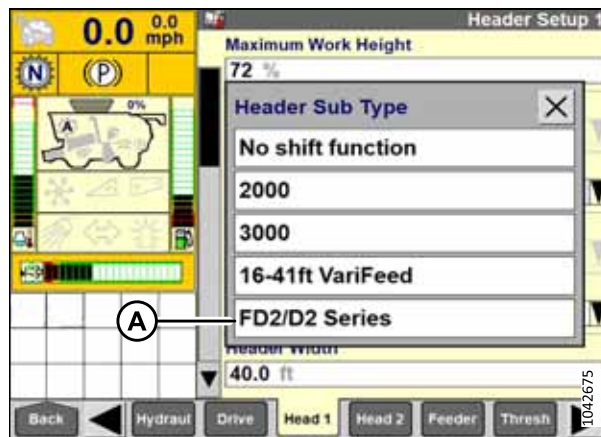


Figure 3.904: New Holland Combine Display

5. Return to the HEAD 1 page and choose FLEXHEAD from FRAME TYPE drop-down menu (A).



Figure 3.905: New Holland Combine Display

6. Select HEAD 2 tab (A).
7. In HEADER SENSORS field (B), select ENABLE.
8. In HEADER PRESSURE FLOAT field (C), select NO.
9. In HEIGHT/TILT RESPONSE field (D), select FAST.

**NOTE:**

AUTO HEADER LIFT field (E) can be set to the user's preference.

10. Press down arrow (F) to go to the next page.

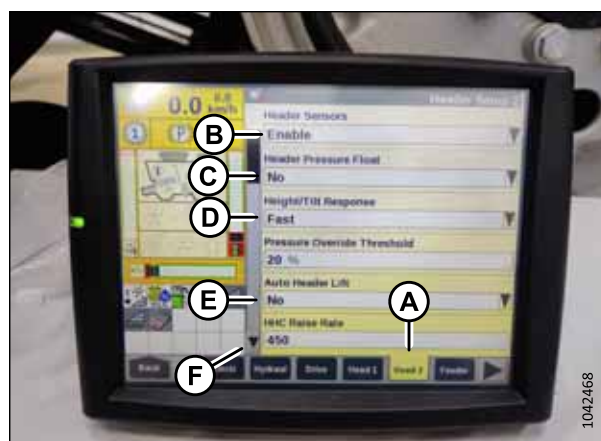


Figure 3.906: New Holland Combine Display

## AUTO HEADER HEIGHT CONTROL SYSTEM

11. In HYDRAULIC REEL field (A), select YES.
12. In HYDRAULIC REEL REVERSE field (B), select YES.



Figure 3.907: New Holland Combine Display

13. In OVERLAP MODE field (A), select MANUAL.
14. In WORK WIDTH RESET field (B), select MANUAL.

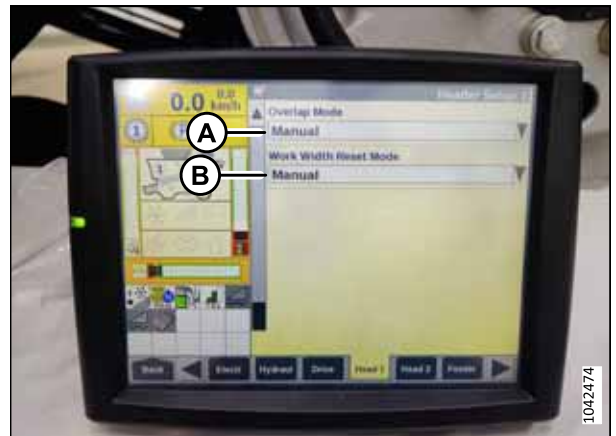


Figure 3.908: New Holland Combine Display

## 3.21 Rostselmash Combines – RSM 161, T500, and TORUM 785

Instructions on using the header's auto header height control (AHHC) system with Rostselmash combines are provided.

### 3.21.1 Calibrating Auto Header Height Control – Rostselmash RSM 161, T500, and TORUM 785

The auto header height control (AHHC) sensor output must be calibrated for each combine, or the AHHC feature will not work properly. The AHHC feature on Rostselmash combines can be calibrated using the automatic calibration procedure.

#### DANGER

Ensure that all bystanders have cleared the area.

#### NOTE:

Changes may have been made to the combine controls or the display since this document was published. For the most up-to-date information, refer to the combine operator's manual.

1. Ensure that the center-link is set to **D**.

#### NOTE:

When calibration is complete, adjust the center-link back to the desired header angle. For instructions, refer to [3.9.5 Header Angle, page 232](#).

2. Set the engine throttle to operating speed.
3. Park the combine on a level surface.
4. Allow the engine to reach normal operating temperature.
5. Lower the header to the ground.
6. Ensure that needle (A) on the float module's float indicator is pointing to 4 (B), as shown.

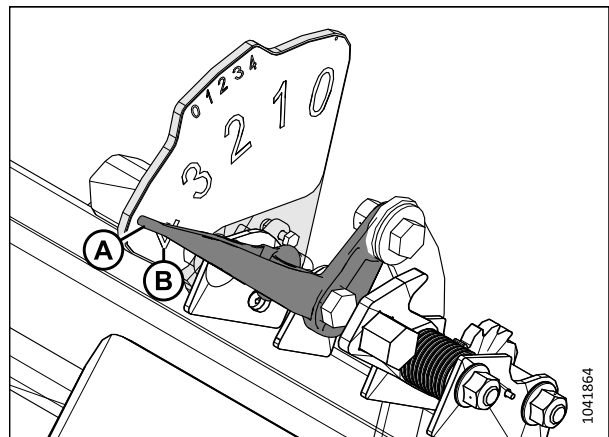


Figure 3.909: Float Indicator

## AUTO HEADER HEIGHT CONTROL SYSTEM

7. Select WRENCH icon (A). SETTINGS window (B) appears.



Figure 3.910: Settings Menu

8. Select CALIBRATIONS icon (A). The CALIBRATION SETTINGS menu appears.



Figure 3.911: Settings Menu – Calibration Button

9. Select GCFS (A).

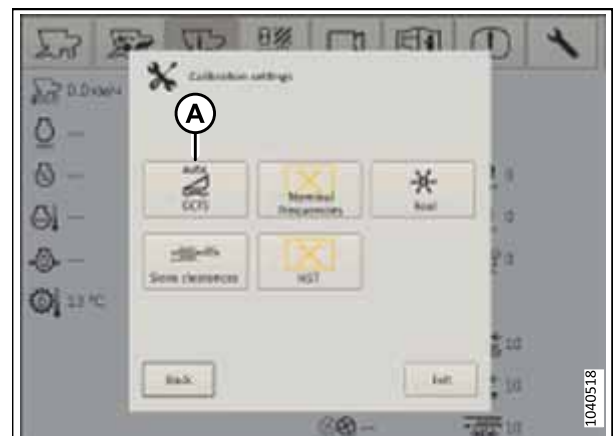


Figure 3.912: Calibration Settings Menu



## AUTO HEADER HEIGHT CONTROL SYSTEM

10. Press START CALIBRATION (A). The header will rise to its maximum height, then fall to the lowest possible position.

**NOTE:**

If the system reports sensor voltages that are out of the acceptable range (0.7–4.3 V), the calibration will fail. The voltage range should be measured at the sensors. For instructions on inspecting the voltage range of the header height sensors, refer to [3.3 Manually Checking Voltage Limits](#), page 296.

11. Adjust the center-link to the desired setting. For instructions, refer to [3.9.5 Header Angle](#), page 232.

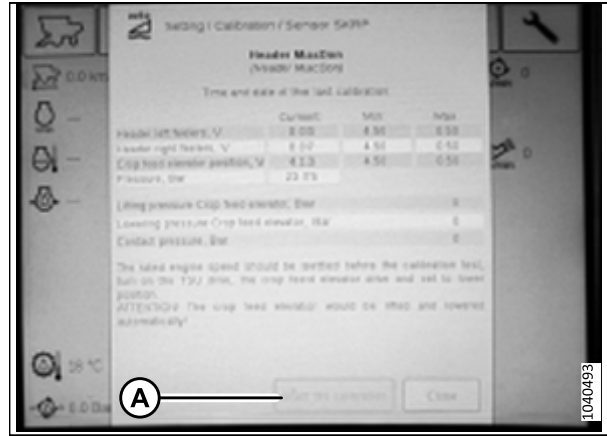


Figure 3.913: Calibration Screen

### 3.21.2 Engaging Auto Header Height Control – Rostselmash RSM 161, T500, and TORUM 785

Once the auto header height control (AHHC) system has been configured on the combine, the AHHC system will need to be activated in the combine’s computer.

**NOTE:**

Changes may have been made to the combine controls or the display since this document was published. For the most up-to-date information, refer to the combine operator’s manual.

**⚠ DANGER**

Ensure that all bystanders have cleared the area.

1. Select WRENCH icon (A). SETTINGS window (B) will appear.
2. Select GCFS (C). The GCFS SETTINGS page will appear.

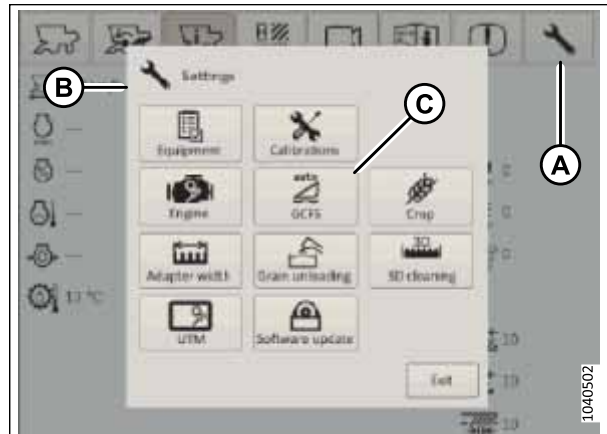


Figure 3.914: Settings Menu



## AUTO HEADER HEIGHT CONTROL SYSTEM

3. Ensure that MODE 1 (A) and MODE 2 (B) are set to CUTTING HEIGHT MAINTAINING MODE.
4. Select OK button (C) to confirm the changes.

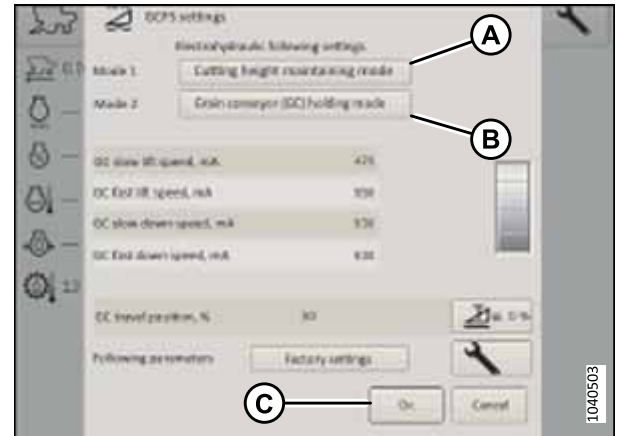


Figure 3.915: Settings Menu

### 3.21.3 Calibrating Reel Speed – Rostselmash RSM 161, T500, and TORUM 785

The reel speed will need to be calibrated before the automatic reel speed feature of the auto header height control (AHC) system on Rostselmash combines can be used.

#### DANGER

Ensure that all bystanders have cleared the area.

#### NOTE:

Changes may have been made to the combine controls or the display since this document was published. For the most up-to-date information, refer to the combine operator's manual.

1. Start the engine.
2. Park the combine on a level surface.
3. Allow the engine to reach normal operating temperature.
4. Select WRENCH icon (A). SETTINGS window (B) appears.



Figure 3.916: Settings Menu

## AUTO HEADER HEIGHT CONTROL SYSTEM

5. Select CALIBRATIONS icon (A). The CALIBRATION SETTINGS window appears.



Figure 3.917: Settings Menu – Calibration Button

6. Select REEL icon (A). The REEL CALIBRATION page appears.

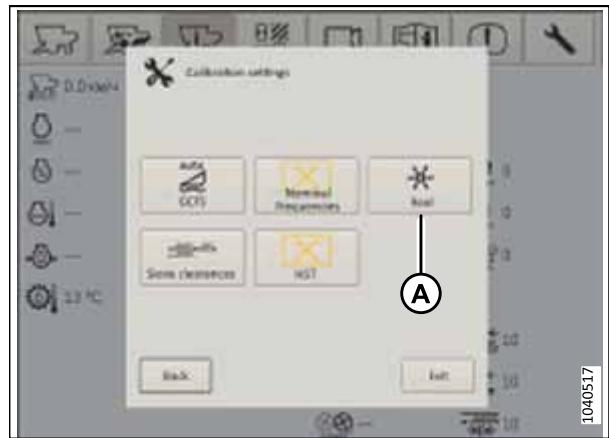


Figure 3.918: Calibration Settings Menu

7. Select START CALIBRATION (A). The display will emit a beep to indicate that the procedure has begun. The reel will begin rotating and will stop when calibration is complete. This procedure may take several minutes to complete.

8. Select OK button (B).

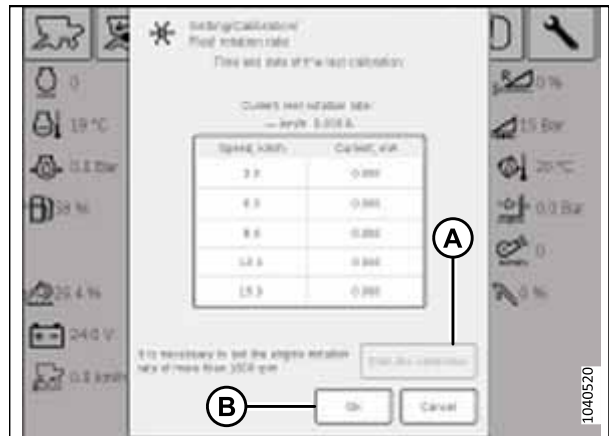


Figure 3.919: Reel Calibration Page

### 3.21.4 Operating Header – Rostselmash RSM 161, T500, and TORUM 785

Once the auto header height control (AHHC) system has been calibrated, the header settings can be optimized using the controls in the combine's cab.

**⚠ DANGER**

Ensure that all bystanders have cleared the area.

**NOTE:**

Changes may have been made to the combine controls or the display since this document was published. For the most up-to-date information, refer to the combine operator's manual.

1. Engage the combine's feeder house. For instructions, refer to the combine operator's manual.
2. Engage the header. For instructions, refer to the combine operator's manual.
3. On the combine control handle, use raise/lower header button (A) to move the header to the desired height.



Figure 3.920: Combine Control Handle

**NOTE:**

Preset height settings should be between 10 and 50% ground pressure, as indicated on GROUND PRESSURE BAR (A).



Figure 3.921: Combine Operating Page

## AUTO HEADER HEIGHT CONTROL SYSTEM

4. Press and hold button (B) for 3 seconds to save the height preset. Press and release button (B) again to cause the header to move to the preset height.
5. If you wish to set another preset on button (C):
  - a. Use raise/lower header button (A) to move the header to another desired height.
  - b. Press and hold button (C) for 3 seconds to save the second height preset. Press and release button (C) again to move the header to the second preset height.

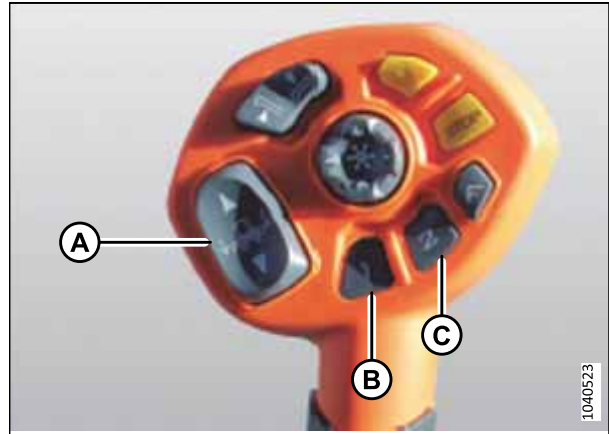


Figure 3.922: Combine Control Handle

## 3.10 Unplugging Cutterbar

If the cutterbar is not working correctly, clear the cutterbar of any obstructions.

### DANGER

To prevent bodily injury or death from the unexpected start-up or fall of a raised machine, always stop the engine and remove the key before leaving the operator's seat, and always engage the safety props before going under the machine for any reason.

### DANGER

Ensure that all bystanders have cleared the area.

### WARNING

Wear heavy gloves when working around or handling knives.

#### IMPORTANT:

Lowering a rotating reel on a plugged cutterbar will damage the reel components.

1. Stop the forward movement of the machine and disengage the header drives.
2. Raise the header to prevent it from filling with dirt.
3. Reverse the combine feeder house and the header drive. If the cutterbar is still plugged, proceed to the next step.
4. If the plug does **NOT** clear, disengage header and raise the header fully.
5. Shut down the engine, and remove the key from the ignition.
6. Engage the header safety props. For instructions, refer to the combine operator's manual.
7. Clean the cutterbar.

### 3.11 Unplugging Float Module Feed Draper

Crop sometimes gets wedged between the feed draper and the feed deck. Follow this procedure to safely clear any obstructions in the float module's feed draper.

 **DANGER**

**Ensure that all bystanders have cleared the area.**

1. Stop the forward movement of the machine and disengage the header drives.
2. Raise the header slightly off the ground, and raise the reel.
3. Turn the side draper speed down to 0.
4. Reverse the combine feed according to the manufacturer specifications (the reverse feed varies among different combine models) and engage the header drive.
5. Slowly increase the side draper speed to the previous settings once the plug has been cleared.

## 3.12 Transport

There are two ways to transport the header: you can attach it to the front of a combine or tow it behind a combine or an agricultural tractor.

For more information, refer to:

- [3.12.1 Transporting Header on Combine, page 545](#)
- [3.12.2 Towing, page 545](#)

### 3.12.1 Transporting Header on Combine

In conditions with good visibility, you can transport the header while it is attached to a combine.



#### WARNING

Do **NOT** drive the combine with the header attached at night, or in conditions which reduce visibility, such as fog or rain. The width of the header may not be apparent under these conditions.



#### CAUTION

- Check the local laws for width regulations and any lighting or marking requirements before transporting on roads.
- Follow all of the recommended procedures in your combine operator's manual for transporting, towing, etc.
- Disengage the header drive clutch when travelling to and from the field.
- Before driving on a roadway, ensure that the lights are clean and working properly. Pivot the amber lamps so that they can be seen by approaching traffic. Always use lamps when travelling on roads.
- Do **NOT** use field lamps on roads—they may confuse other drivers.
- Before driving on a roadway, clean vehicle signs and reflectors, adjust the rear view mirrors, and clean the windows.
- Lower the reel fully and raise the header (unless you are transporting the header across hills).
- Watch out for roadside obstructions, oncoming traffic, and bridges.
- When travelling downhill, reduce your speed and keep the header at a minimum height to provide maximum stability in case you stop for any reason. At the bottom of the hill, raise the header completely to avoid contacting the ground.

### 3.12.2 Towing

Headers with the EasyMove™ Transport option can be towed behind a combine or an agricultural tractor at a maximum speed of 32 km/h (20 mph).

For instructions, refer to the towing vehicle's operator's manual.



### *Attaching Header to Towing Vehicle*

The header can be towed using a properly configured windrower, a combine, or an agricultural tractor.

#### **CAUTION**

Follow the instructions below to prevent loss of control leading to bodily injury and/or machine damage:

- The weight of the towing vehicle must exceed the weight of the header to ensure adequate control and braking performance.
- Only use a combine or an agricultural tractor to tow the header.
- Ensure that the reel is fully lowered and back on the support arms to stabilize the header during transport. For headers with hydraulic reel fore-aft, never connect the fore-aft couplers to each other or the circuit will be complete and the reel could creep forward during transport.
- Ensure that all of the pins are properly secured in the transport position at the wheel supports, at the cutterbar support, and at the hitch.
- Check the condition of the tires and the tire pressure before transporting the header.
- Connect the hitch to the towing vehicle using a proper hitch pin with a spring locking pin or another suitable fastener.
- Attach the hitch safety chain to the towing vehicle. Adjust the safety chain length to provide only enough slack to permit turning.
- Connect the header seven-pole plug wiring harness to the mating receptacle on towing vehicle. (The seven-pole receptacle is available from your Dealer parts department.)
- Ensure that the lights are functioning properly and clean the slow moving vehicle sign and other reflectors. Use the flashing warning lights unless prohibited by law.

### *Precautions for Towing Header*

Review this list of precautions before attaching and towing a header behind a combine or an agricultural tractor.

#### **CAUTION**

Adhere to the following instructions to prevent loss of control leading to bodily injury and/or machine damage:

- Do NOT exceed 32 km/h (20 mph).
- For slippery or rough conditions, reduce the transport speed to less than 8 km/h (5 mph).
- Turn corners at only very low speeds (8 km/h [5 mph] or less) as the header is less stable when turning corners. Do NOT accelerate when making or coming out of a turn.
- Obey all of the highway traffic regulations in your area when transporting the header on public roads. Use flashing amber lights unless prohibited by law.

### 3.12.3 Converting from Transport to Field Position (Option)

Convert the header back to field position after you have towed it to a new location.

#### *Moving Left Outboard Wheel From Transport to Working Position – ContourMax™ Option*

The left outboard wheel need to be repositioned to the working position after being in the transport position.

#### DANGER

To avoid bodily injury or death from unexpected startup or fall of raised header, stop the engine, remove the key, and engage the safety props before going under the header. If you are using a lifting device to support the header, be sure that the header is secure before proceeding.

#### DANGER

Ensure that all bystanders have cleared the area.

1. Raise the header fully.
2. Shut down the engine, and remove the key from the ignition.
3. Engage the header safety props or support the header on blocks on level ground. If you are using blocks to support the header, ensure that the header is approximately 914 mm (36 in.) off the ground.
4. Remove lynch pin (A).
5. Remove locking pin (B).
6. Slide wheel assembly (C) out of storage bracket (D).

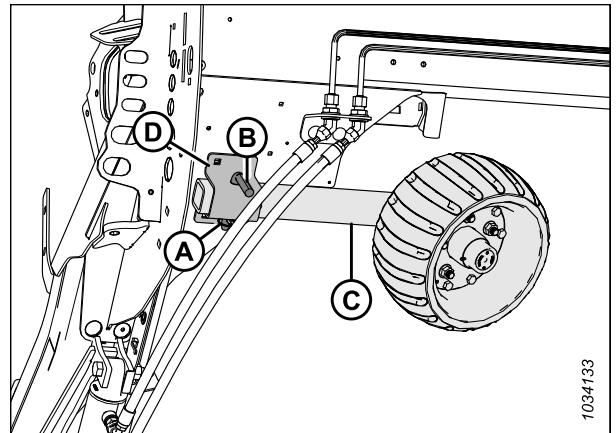


Figure 3.923: Left Wheel Assembly

7. With the wheel facing inboard, align wheel assembly (C) with the isolator assembly and slide it toward the front of the header until the pin holes line up.
8. Install locking pin (B).
9. Install lynch pin (A).

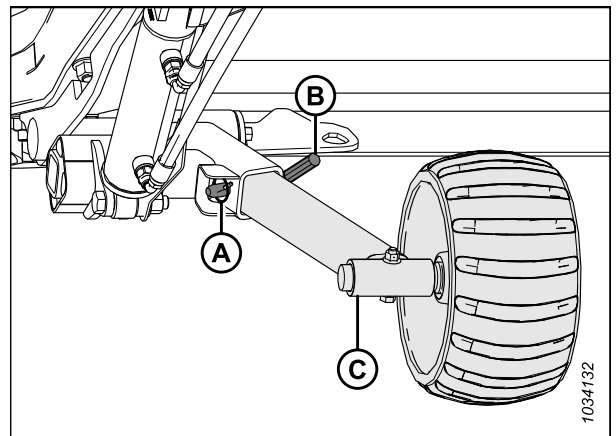


Figure 3.924: Left Wheel Assembly

## AUTO HEADER HEIGHT CONTROL SYSTEM

### Removing Tow-Bar

Remove the tow bar from the transport location when converting the header from the transport position.

1. Block the header tires with wheel chocks (A) to prevent the header from rolling.



Figure 3.925: Tire Blocking

2. Disconnect electrical connector (A) and safety chain (B) from the towing vehicle and store it as shown.
3. If removing a tow-bar with an extension, proceed to Step 4, [page 548](#). If removing a tow-bar without an extension, proceed to Step 16, [page 550](#).

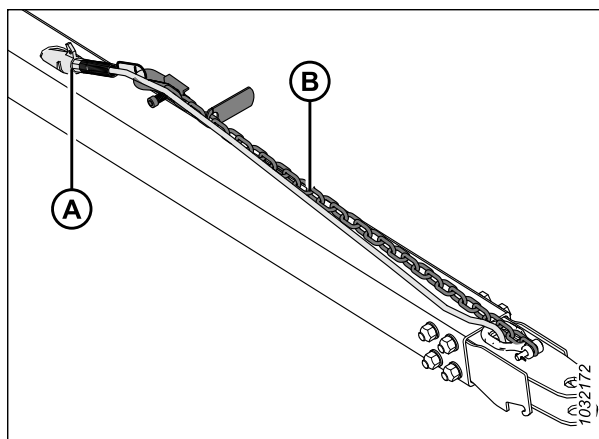


Figure 3.926: Tow-Bar Assembly

### Removing tow-bar installed with an extension:

4. Disconnect tow-bar harness (A) from extension harness (B).
5. Remove lynch pin (C) from the latch.

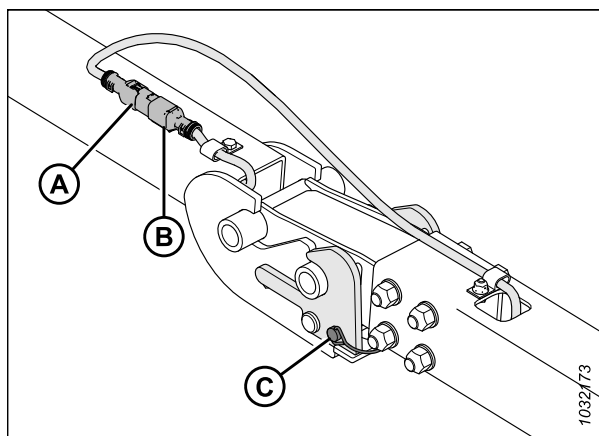


Figure 3.927: Tow-Bar / Extension Harness

## AUTO HEADER HEIGHT CONTROL SYSTEM

6. Secure tow-bar harness (A) in storage location.
7. Lift up on the hitch near the latch connection to take weight off of the latch. While lifting, pull up on latch handle (B) to clear the tow-bar lug, then slowly lower the assembly to the ground.
8. Lift the end of tow-bar (C) and pull it away from extension (D).

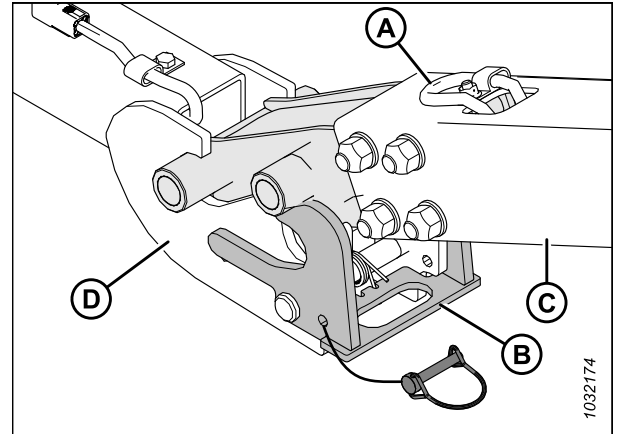


Figure 3.928: Tow-Bar / Extension Joint

9. Unplug tow-bar extension electrical harness (A) from left transport pivot harness (B).

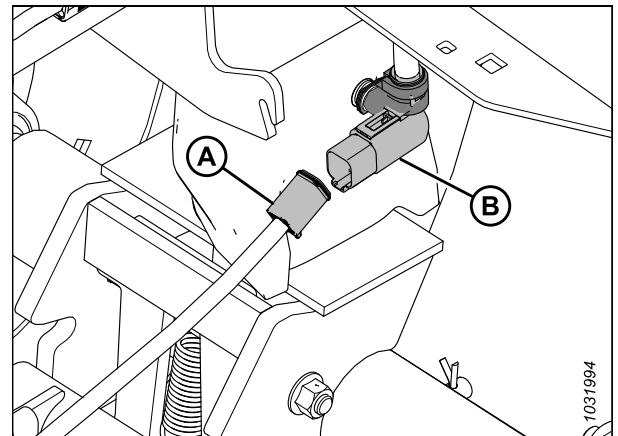


Figure 3.929: Tow-Bar Electrical Connection

10. Remove lynch pin (A) from transport pivot (B).
11. Push back on latch (C) to free extension (D).

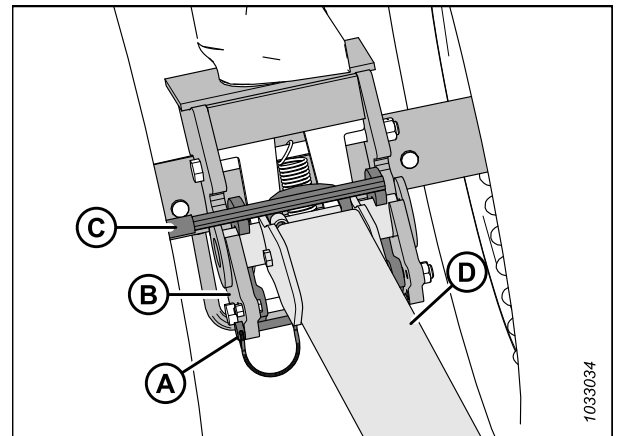


Figure 3.930: Tow-Bar Extension and Transport Pivot

## AUTO HEADER HEIGHT CONTROL SYSTEM

12. Lift extension (A) and pull it away from transport pivot (B).
13. Secure extension harness (C) inside tow-bar extension tube (A).
14. Reinstall the lynch pin in the left transport pivot for safe keeping.
15. For tow-bar storage, refer to [Storing Tow-Bar, page 551](#).

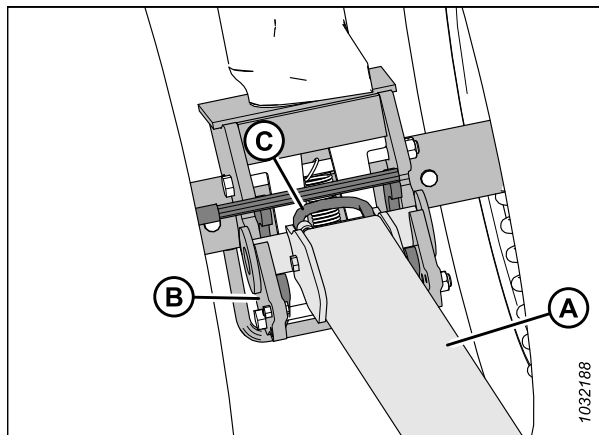


Figure 3.931: Latch Disengaged from Extension

### **Removing tow-bar installed without an extension:**

16. Unplug tow-bar extension electrical harness (A) from left transport pivot harness (B).

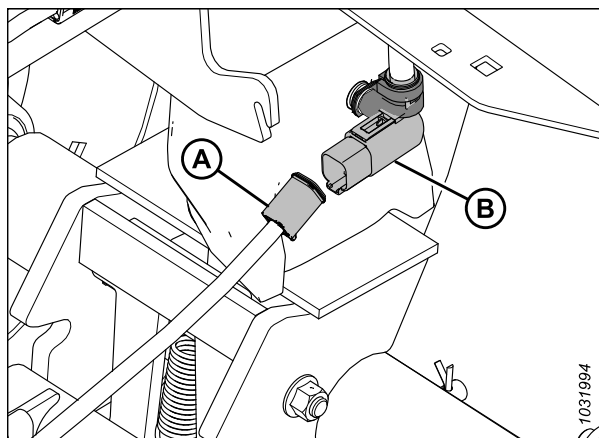


Figure 3.932: Tow-Bar Electrical Connection

17. Remove lynch pin (A), then push back on latch (B) to free the tow-bar.

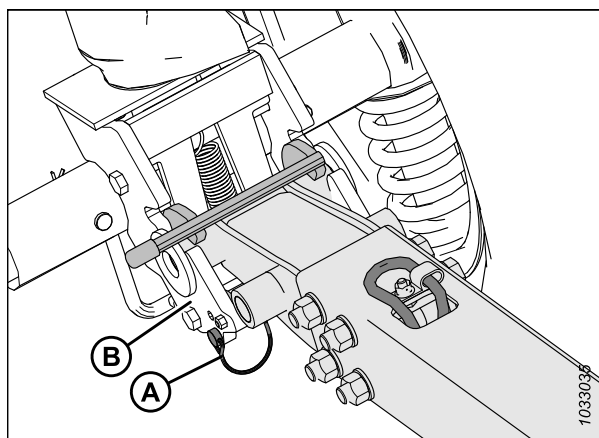


Figure 3.933: Tow-Bar and Left Transport Pivot

## AUTO HEADER HEIGHT CONTROL SYSTEM

18. Lift tow-bar (A) and pull it away from transport pivot (B).
19. Reinstall the lynch pin in the left transport pivot for safe keeping.
20. For tow-bar storage, refer to *Storing Tow-Bar, page 551*.

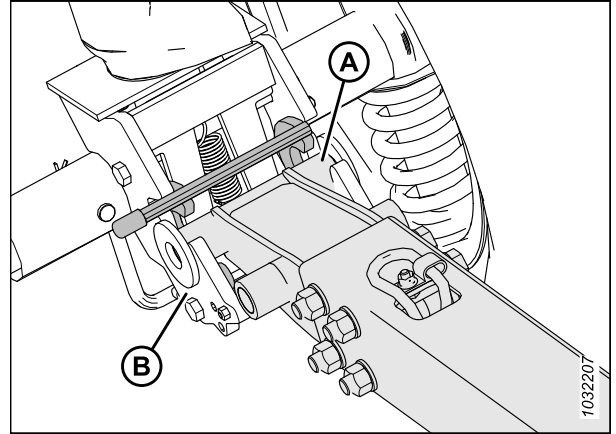


Figure 3.934: Tow-Bar and Left Transport Pivot

### Storing Tow-Bar

Store the tow bar in the backtube when it is not in use.

#### Tow-bar Extension

1. Insert tube end (B) of tow-bar extension (A) onto pin (C).
2. Rotate the tow-bar extension to cradle (D).

**NOTE:**

To prevent the tow-bar extension from shaking loose, ensure that the extension bar engages the groove in bracket (E).

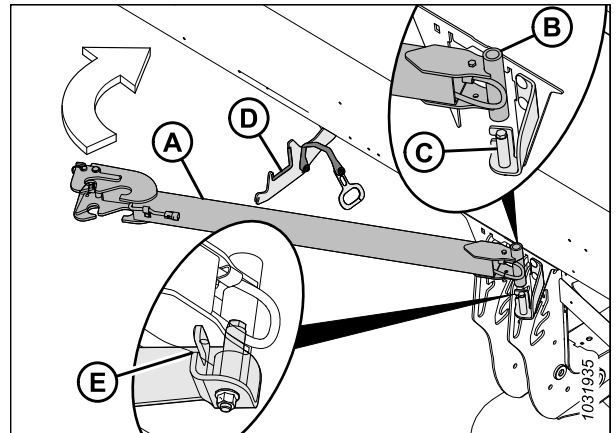


Figure 3.935: Tow-Bar Extension Storage

3. Secure the tow-bar extension by hooking strap handle (A) onto the notch in cradle (B).

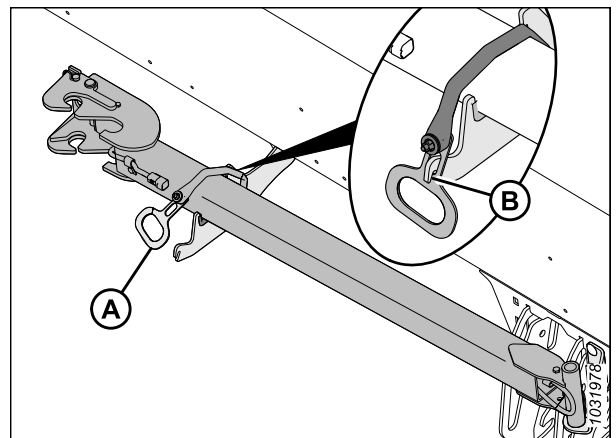


Figure 3.936: Tow-Bar Extension Storage

## AUTO HEADER HEIGHT CONTROL SYSTEM

### Tow-bar

4. Open the left endshield. For instructions, refer to [Opening Header Endshields, page 41](#).
5. With the tow chain and harness (A) facing up, insert hitch end (B) of the tow-bar into the left backtube.

#### IMPORTANT:

The header endshield has been removed from the illustration for clarity.

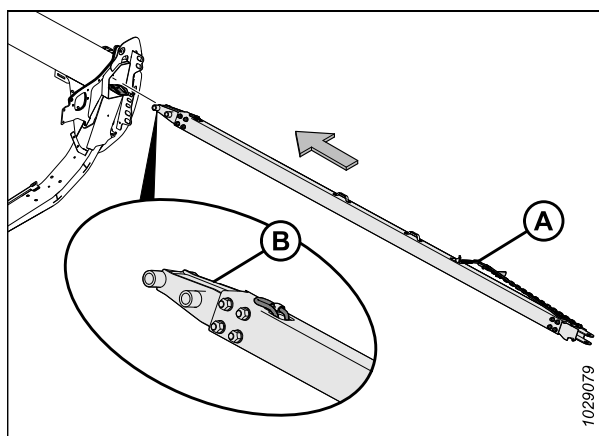


Figure 3.937: Hitch End

6. Slide the tow-bar inside the backtube until hooks (A) engage the slots of support angle (B).
7. Close the header endshield. For instructions, refer to [Closing Header Endshields, page 42](#).

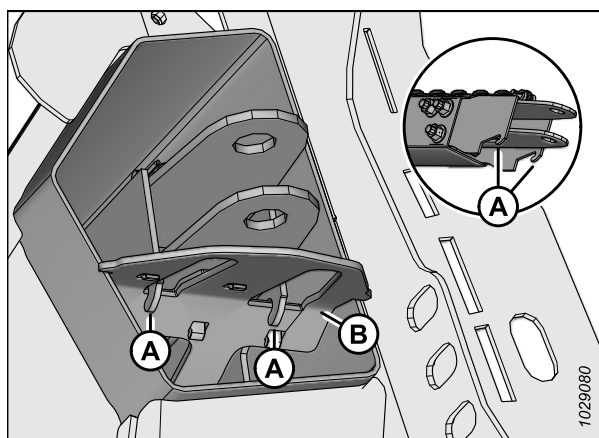


Figure 3.938: Clevis End Retainer Hooks

### Moving Front (Left) Wheels into Field Position

This procedure explains how to move the wheels to the highest storage position, but you may want to use a lower position, depending on whether or not you want the wheels to support the header during field operations.

#### NOTE:

This procedure assumes that the tow-bar has been removed. For instructions on removing the tow-bar, refer to [Removing Tow-Bar, page 548](#).

#### DANGER

To prevent bodily injury or death from the unexpected start-up or fall of a raised machine, always stop the engine, remove the key, and engage the safety props before going under the header for any reason.

#### DANGER

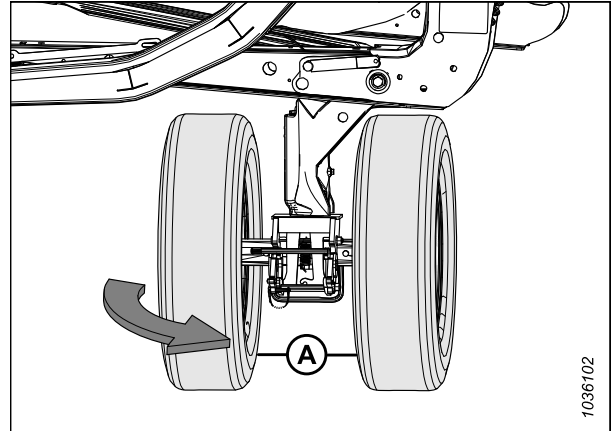
Ensure that all bystanders have cleared the area.

1. Raise the header until the transport wheels are 51–102 mm (2–4 in.) off the ground.
2. Shut down the engine, and remove the key from the ignition.



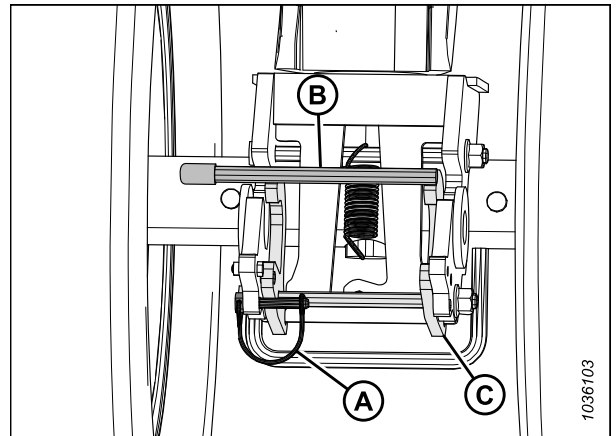
## AUTO HEADER HEIGHT CONTROL SYSTEM

- Engage the header safety props. For instructions, refer to the combine operator's manual.
- Turn left transport wheel assembly (A) 90° in the direction shown.



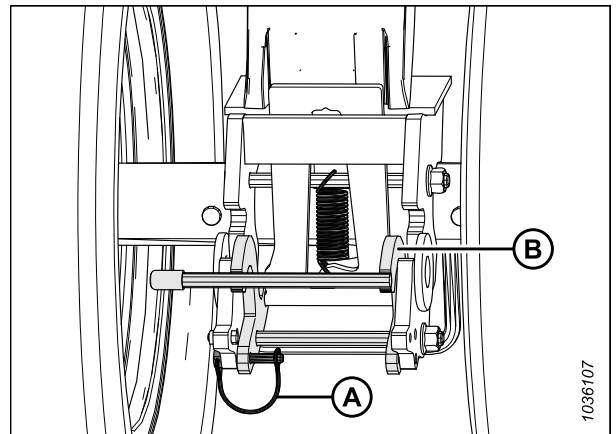
**Figure 3.939: Left Transport Wheels in Transport Mode**

- Remove lynch pin (A). Pull handle (B) to engage latch (C)—this will prevent the transport wheel assembly from rotating.



**Figure 3.940: Left Transport Wheels – Rotation Lock Latch Disengaged**

- Secure latch (B) with lynch pin (A).



**Figure 3.941: Left Transport Wheels – Rotation Lock Latch Engaged**

## AUTO HEADER HEIGHT CONTROL SYSTEM

7. To unlock the pivot, use your foot to apply pressure to bolt (B) while pushing handle (A) downward.

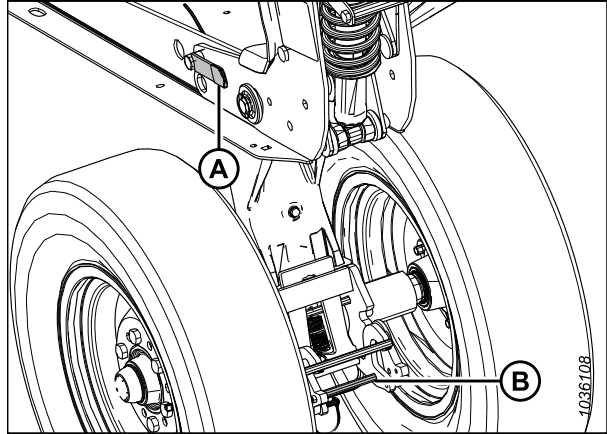


Figure 3.942: Left Transport Wheels – Pivot Released

8. Lift up on handle (A) while pulling back on handle (B) to lift the left wheel assembly into the highest storage position.

**NOTE:**

Parts have been removed from the illustration for clarity.

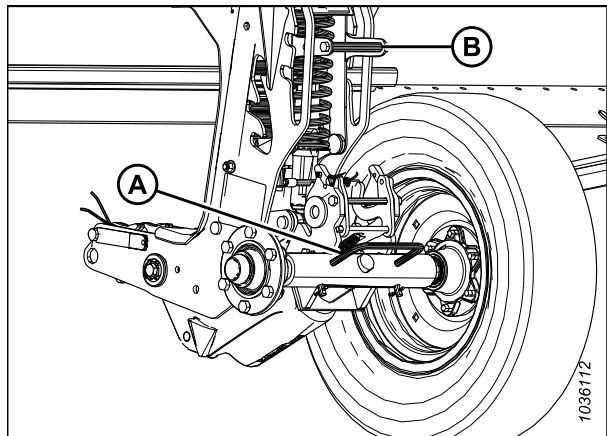


Figure 3.943: Left Transport Wheels in Highest Storage Position

9. Ensure that pin (A) is visible at the highest storage position in plate (B).

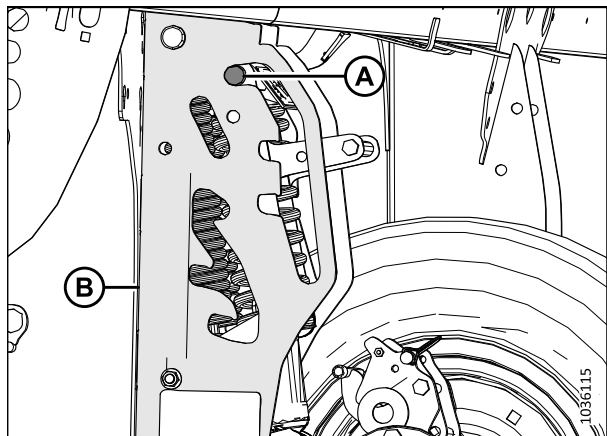


Figure 3.944: Left Transport Wheel Pivot Pin in Highest Storage Position

## AUTO HEADER HEIGHT CONTROL SYSTEM

### *Moving Rear (Right) Wheels into Field Position*

This procedure explains how to move the wheels to the highest storage position, but you may want to use a lower position, depending on whether or not you want the wheels to support the header during field operations.

#### **DANGER**

To prevent bodily injury or death from the unexpected start-up or fall of a raised machine, always stop the engine, remove the key, and engage the safety props before going under the header for any reason.

#### **DANGER**

Ensure that all bystanders have cleared the area.

1. Raise the header until the transport wheels are 51–102 mm (2–4 in.) off the ground.

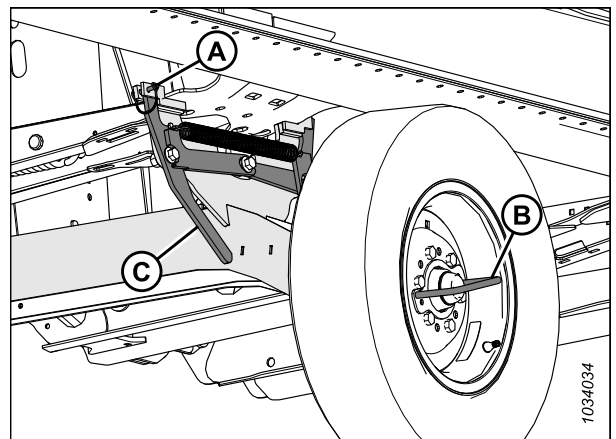
#### **NOTE:**

Raise the header high enough to engage the safety props—you will need to work under the header to complete this procedure.

#### **NOTE:**

If engaging the safety props requires raising the header to a height where it is inconvenient to work on, use blocks to support the header so that the transport wheels are 51–102 mm (2–4 in.) off the ground.

2. Shut down the engine, and remove the key from the ignition.
3. Engage the header safety props. For instructions, refer to the combine operator's manual.
4. On the right transport axle, remove lynch pin (A) from the right transport axle latch.
5. Support the right transport axle using wheel handle (B), then push handle (C) to release the right transport axle from the header frame.
6. Lower the right transport axle to the ground using wheel handle (B).
7. Reinstall lynch pin (A) into the latch.



**Figure 3.945: Right Transport Axle Latched in Transport Position**

## AUTO HEADER HEIGHT CONTROL SYSTEM

- Lift and rotate right transport axle (A) in the direction shown using the wheel handle.

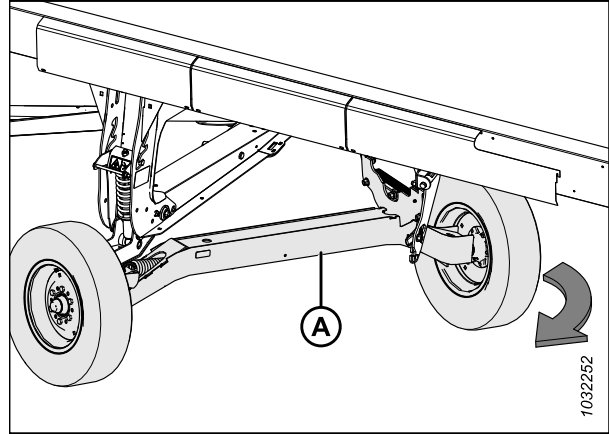


Figure 3.946: Right Transport Axle Rotation

- Using wheel handle (A), lift and position right transport axle (B) to field support (C) to engage latch (D).

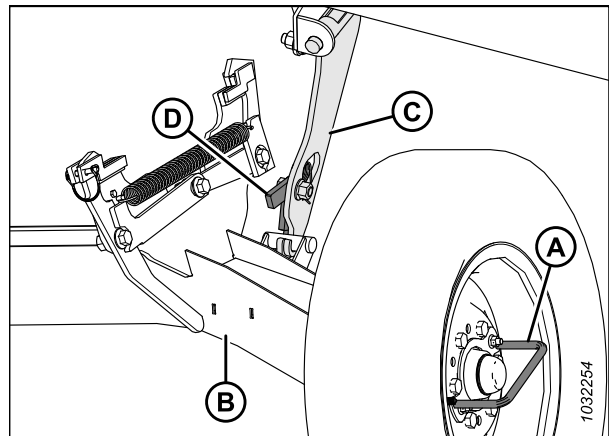


Figure 3.947: Right Transport Axle Latched in Field Position

- Pull transport height adjustment handle (A) and lift axle pivot handle (B) to move the axle to the highest storage position. Ensure that pin (C) is visible at the highest storage position as shown.
- Adjust the skid shoe position at the right transport leg to match the other skid shoes. For instructions, refer to [Adjusting Inner Skid Shoes, page 207](#).

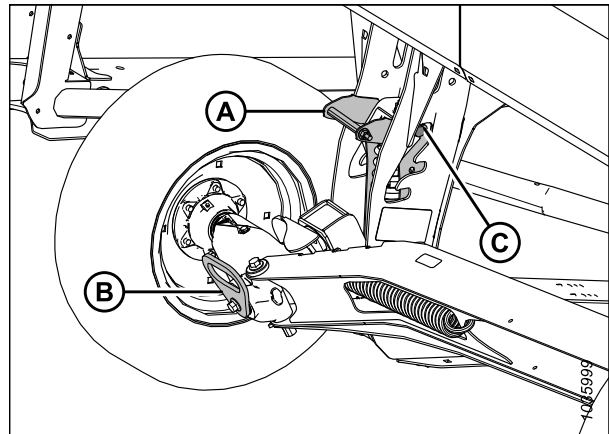


Figure 3.948: Right Transport Wheels in Highest Storage Position

### 3.12.4 Converting from Field to Transport Position (Option)

Convert the header to the transport position before towing it to a new location.

#### *Moving Left Outboard Wheel From Working to Transport Position*

The left outboard wheel need to be moved to the transport position before you can tow the header.

**⚠ DANGER**

To avoid bodily injury or death from unexpected startup or fall of raised header, stop the engine, remove the key, and engage the safety props before going under the header. If you are using a lifting device to support the header, be sure that the header is secure before proceeding.

**⚠ DANGER**

Ensure that all bystanders have cleared the area.

1. Raise the header fully.
2. Shut down the engine, and remove the key from the ignition.
3. Engage the header safety props or support the header on blocks on level ground. If you are using blocks to support the header, ensure that the header is approximately 914 mm (36 in.) off the ground.
4. Remove lynch pin (A).
5. Remove locking pins (B).
6. Slide left wheel assembly (C) towards the back of the header.

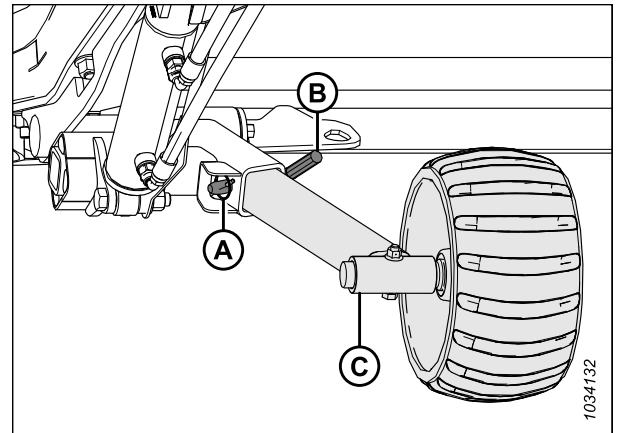


Figure 3.949: Left Wheel Assembly

7. With the wheel facing out, slide left wheel assembly (C) into storage bracket (D).
8. Install locking pin (B).
9. Install lynch pin (A).

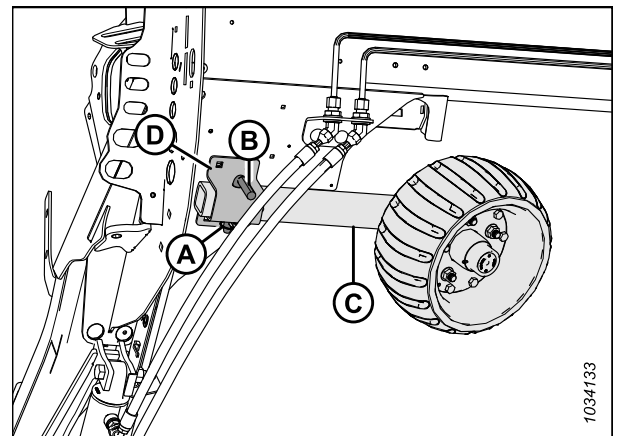


Figure 3.950: Left Wheel Assembly

## AUTO HEADER HEIGHT CONTROL SYSTEM

### *Moving Front (Left) Wheels into Transport Position*

The front (left) wheels are located closest to the towing vehicle. To prepare the header for transport, lower the wheels to the ground and rotate them to face the direction of travel.

#### **DANGER**

To prevent bodily injury or death from the unexpected start-up or fall of a raised machine, always stop the engine, remove the key, and engage the safety props before going under the header for any reason.

#### **DANGER**

Ensure that all bystanders have cleared the area.

#### **CAUTION**

Stand clear of the wheels and release the linkage carefully; the wheels will drop suddenly once the mechanism is released.

1. Raise the header fully.
2. Shut down the engine, and remove the key from the ignition.
3. Engage the header safety props or support the header on blocks on level ground. If you are using blocks to support the header, ensure that the header is approximately 914 mm (36 in.) off of the ground.
4. Adjust the gauge wheel height to transport position (lowest slot). Pull suspension handle (A) outward and push down on axle pivot handle (B) until transport position is reached.

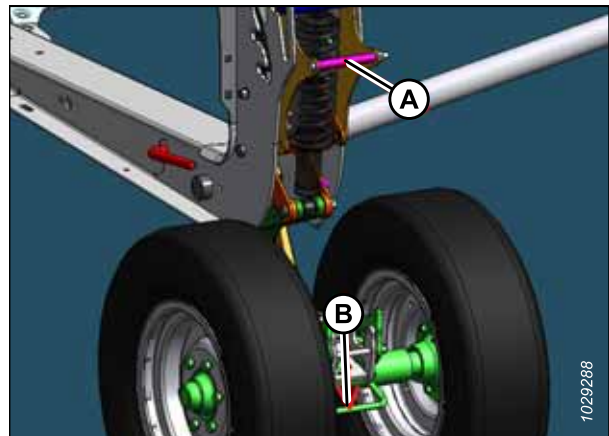


Figure 3.951: Front Transport Wheels

5. Secure the left transport pivot by pushing pivot handle (A) forward until the latch is engaged.
6. Pull back on the pivot handle to ensure that the latch is fully engaged.



Figure 3.952: Front Transport Wheels

## AUTO HEADER HEIGHT CONTROL SYSTEM

7. Remove clevis pin (A) securing the latch.
8. Push pivot handle (B) up to unlock the wheel assembly.

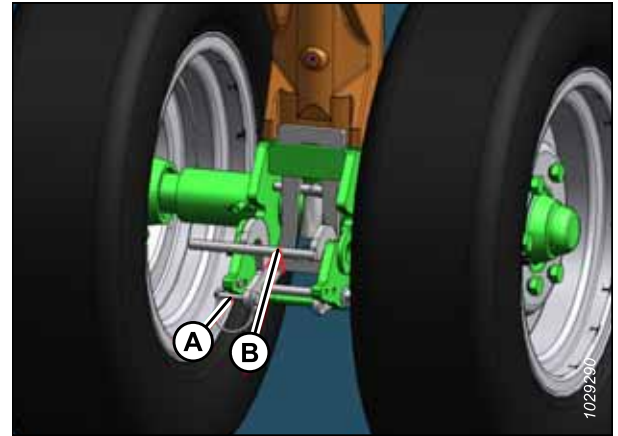


Figure 3.953: Front Transport Wheels

9. Turn front wheel assembly (A) 90° clockwise.

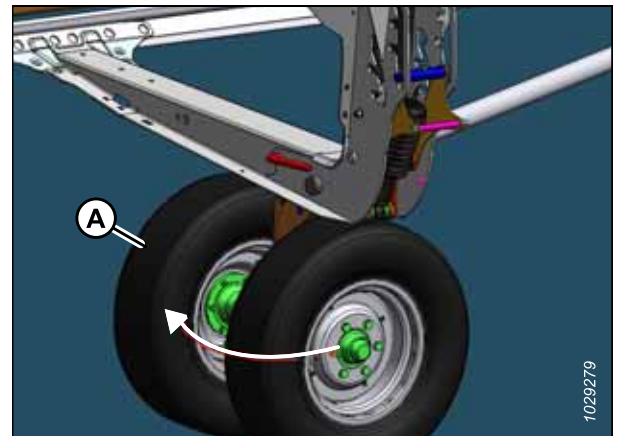


Figure 3.954: Front Transport Wheels

### *Moving Rear (Right) Wheels into Transport Position*

The header must be converted into transport position before towing the header.

#### **DANGER**

To prevent bodily injury or death from the unexpected start-up or fall of a raised machine, always stop the engine, remove the key, and engage the safety props before going under the header for any reason.

#### **CAUTION**

Stand clear of the wheels and release the linkage carefully; the wheels will drop suddenly once the mechanism is released.

1. Fully raise the skid shoe at the right transport axle. For instructions, refer to [Adjusting Inner Skid Shoes, page 207](#).



## AUTO HEADER HEIGHT CONTROL SYSTEM

2. Adjust the gauge wheel height to transport position (lowest slot) as follows:
  - If in the top slot, push on handle (A) to release it.
  - If in the mid slot, pull on handle (A) to release it.
3. Pull suspension handle (A) outward and push down on axle pivot handle (B).

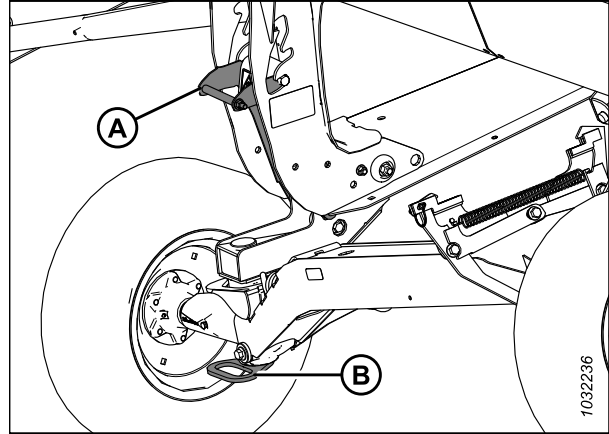


Figure 3.955: Gauge Wheels

4. Push down on latch (A) at right field support (B) to unlock it.

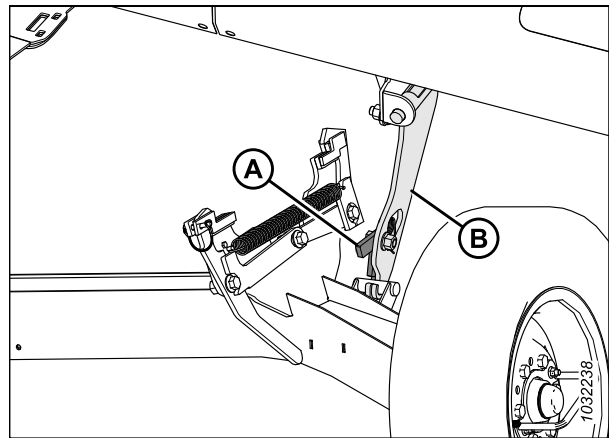


Figure 3.956: Right Field Support

5. Lift wheel handle (A) to remove right transport axle (B) from right field support (C), then lower the right transport axle to the ground.

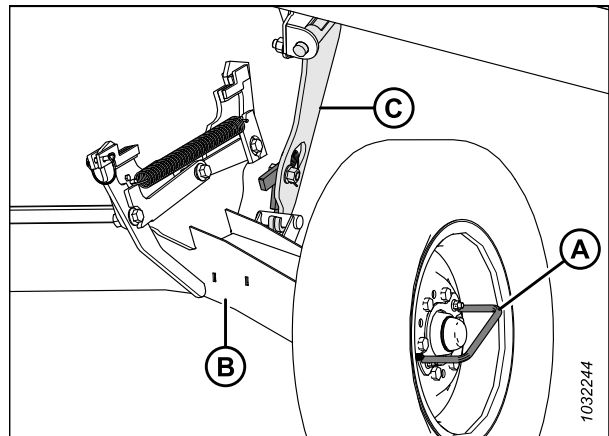


Figure 3.957: Right Field Support

## AUTO HEADER HEIGHT CONTROL SYSTEM

6. Use the wheel handle and rotate right transport axle (A) under the header frame.

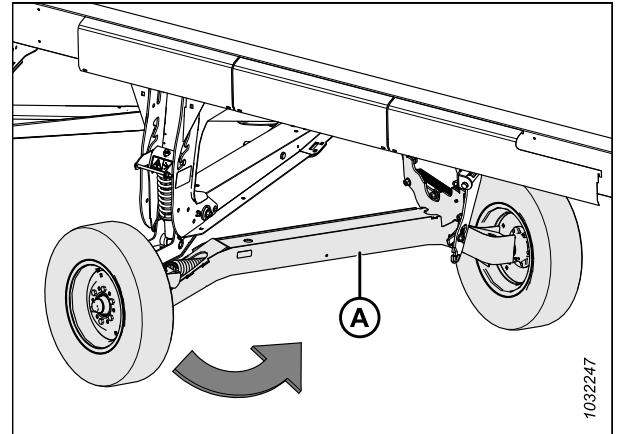


Figure 3.958: Right Transport Axle

7. Remove clevis pin (A) from the right transport axle latch.
8. Lift the right transport axle with wheel handle (B) until the latch engages.
9. Push down on wheel handle (B) to ensure that the latch is engaged.
10. Secure the latch by reinstalling clevis pin (A).

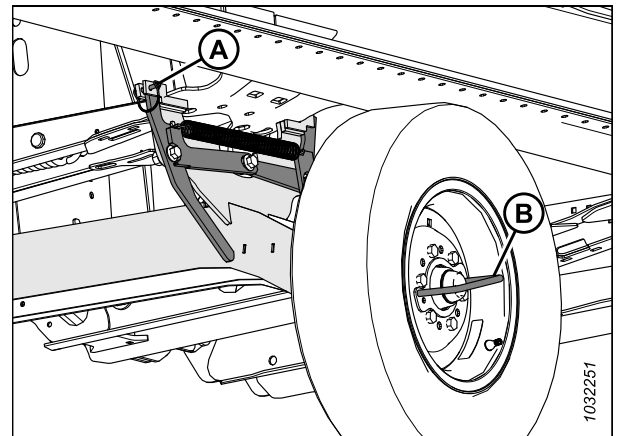


Figure 3.959: Right Transport Axle

### *Removing Tow-Bar from Storage*

When you are converting the header to the transport position, you must remove the tow-bar from its backtube storage location.

#### ***Tow-Bar Extension***

1. Remove strap (A) from cradle (B) to release tow-bar extension (C).
2. Rotate the tow-bar extension to unlock it from pin (D).
3. Lift tow-bar extension (C) away from pin (D).

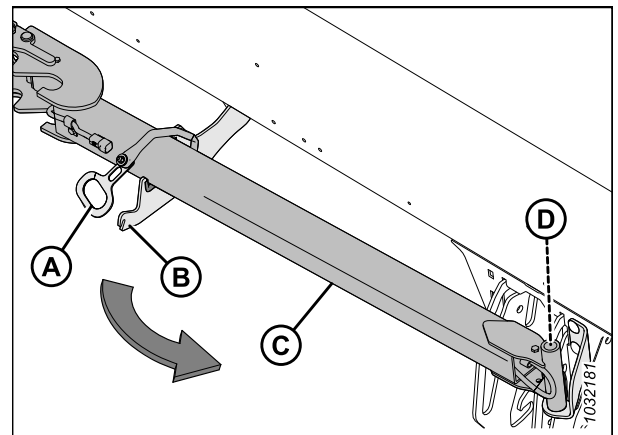


Figure 3.960: Tow-Bar Extension in Storage

## AUTO HEADER HEIGHT CONTROL SYSTEM

### Tow-Bar

4. Open the left endshield. For instructions, refer to [Opening Header Endshields, page 41](#).
5. Pull the tow-bar forward until it hits the stop. Lift the tow-bar to release clevis stop (C) and hook (A) from support angle (B), then pull it out of the tube.

**NOTE:**

The backtube is transparent in the illustration.

6. Slide the tow-bar out from the header backtube.

**IMPORTANT:**

Avoid contact with any nearby hydraulic or electrical hoses and lines.

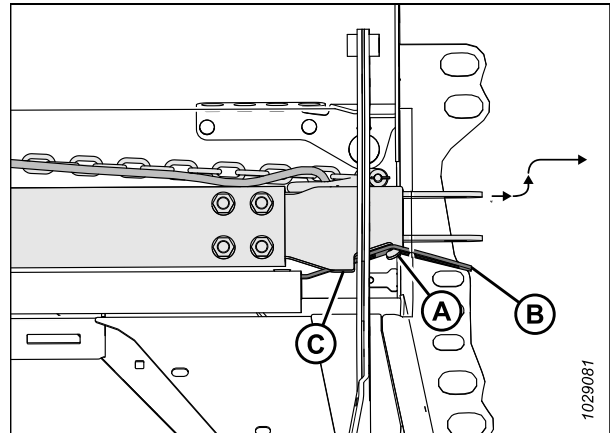


Figure 3.961: Tow-Bar in Storage

### Attaching Tow-Bar

The tow-bar consists of two sections which make storage and handling easier.

1. Block the header tires with wheel chocks (A) to prevent the header from rolling.
2. Remove the tow-bar from storage. For instructions, refer to [Removing Tow-Bar from Storage, page 561](#).
3. If you are installing a tow-bar and extension, proceed to Step 4, [page 563](#). If you are installing a tow-bar only, proceed to Step 18, [page 564](#).

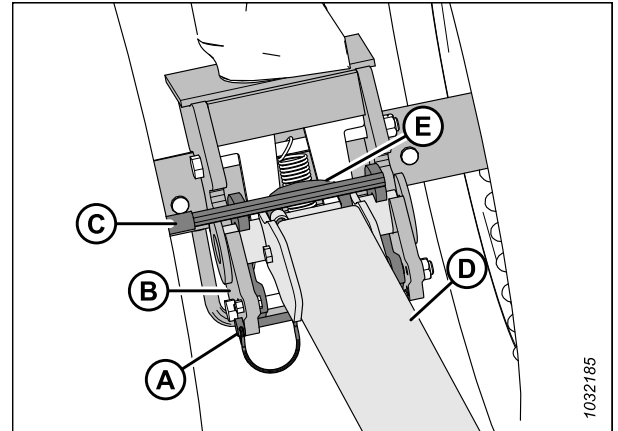


Figure 3.962: Tire Blocking

## AUTO HEADER HEIGHT CONTROL SYSTEM

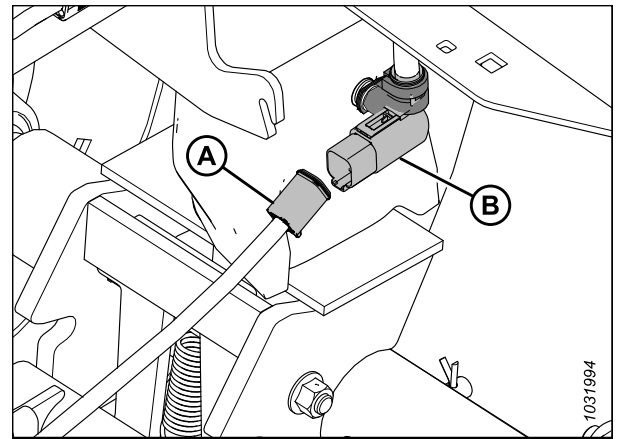
### *Installing tow-bar and extension:*

4. Remove lynch pin (A) from left transport pivot (B).
5. Push extension (D) into the lugs of left transport pivot (B) until latch (C) engages.
6. Reinstall lynch pin (A) onto the transport pivot to secure the extension.
7. Retrieve the end of extension harness (E) from inside of the extension tube.



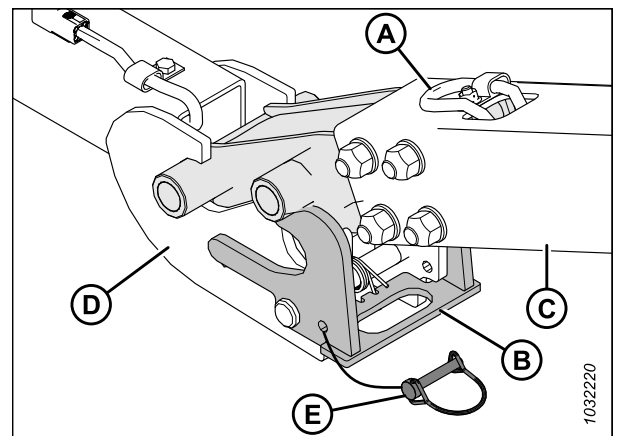
**Figure 3.963: Tow-Bar Extension to Left Transport Pivot**

8. Connect extension wiring harness (A) to left transport pivot harness (B).



**Figure 3.964: Tow-Bar Electrical Connection**

9. Remove lynch pin (E) from latch (B).
10. Position end of tow-bar (C) on the extension lugs, then lower the tow-bar to the ground.
11. Lift extension (D) to engage latch (B) to tow-bar (C).
12. Retrieve the end of tow-bar harness (A) from its storage location.



**Figure 3.965: Tow-Bar to Extension**

## AUTO HEADER HEIGHT CONTROL SYSTEM

13. Connect tow-bar harness (A) to extension harness (B).
14. Reinstall lynch pin (C) onto the latch to secure the tow-bar.

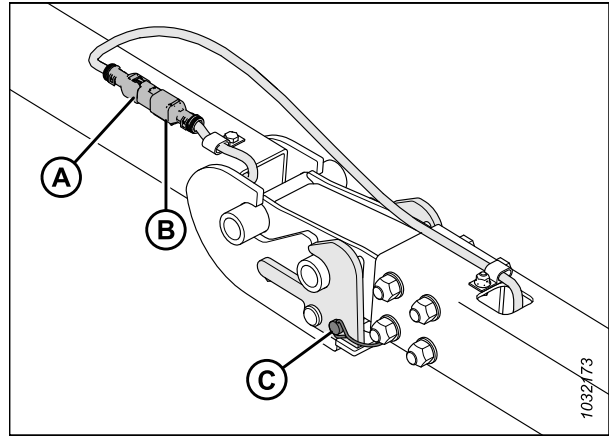


Figure 3.966: Tow-Bar / Extension Harness

15. Retrieve tow-bar wiring harness (A) and safety chain (B) from its storage location.
16. Connect the tow-bar wiring harness to the vehicle, and secure the safety chain from the tow-bar to the tow vehicle.
17. Turn on the tow vehicle's 4-way flashers and check that all of the lights on the header are working.

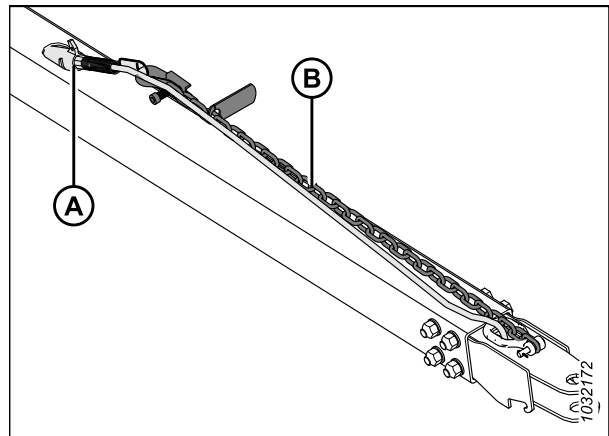


Figure 3.967: Tow-Bar Wiring Harness

### ***Installing tow-bar only:***

18. Remove lynch pin (A) from left transport pivot (B).
19. Push tow-bar (C) into the lugs of left transport pivot (B) until latch (D) engages.
20. Reinstall lynch pin (A) onto the transport pivot to secure the tow-bar.
21. Retrieve the end of tow-bar harness (E).

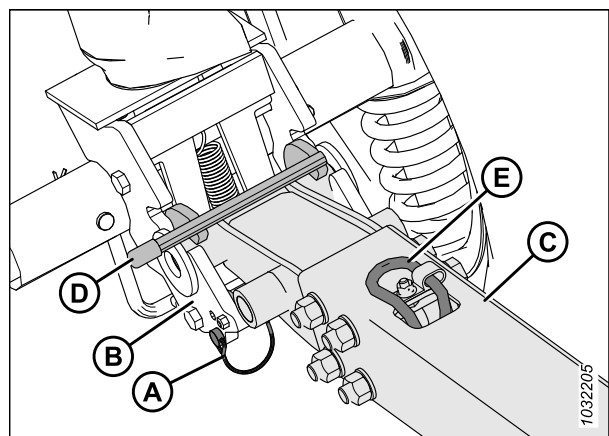


Figure 3.968: Tow-Bar and Left Transport Pivot

## AUTO HEADER HEIGHT CONTROL SYSTEM

22. Connect extension wiring harness (A) to left transport pivot harness (B).

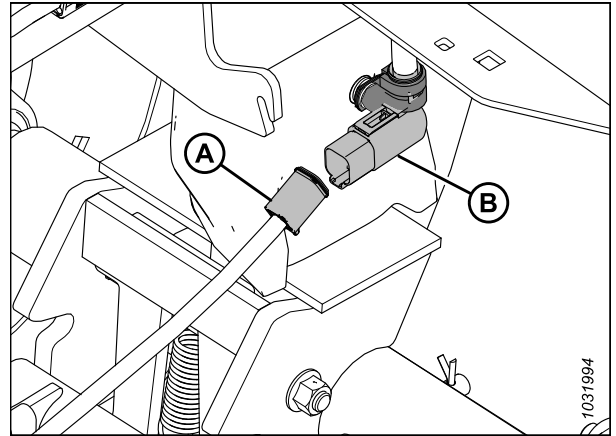


Figure 3.969: Tow-Bar Electrical Connection

23. Retrieve tow-bar wiring harness (A) and safety chain (B) from its storage location.
24. Connect the tow-bar wiring harness to the vehicle, and secure the safety chain from the tow-bar to the tow vehicle.
25. Turn on the tow vehicle's 4-way flashers and check that all of the lights on the header are working.

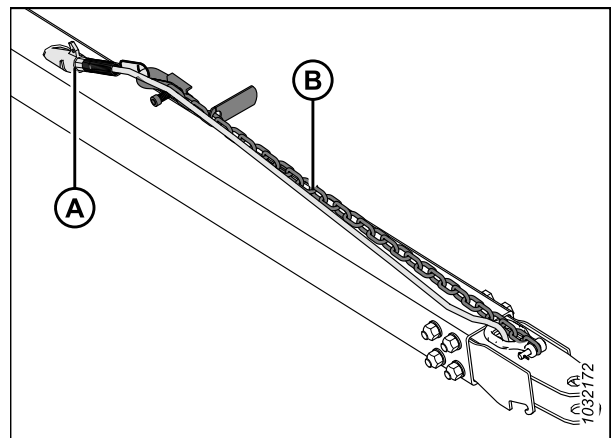


Figure 3.970: Tow-Bar Wiring Harness





## Chapter 4: Maintenance and Servicing

This chapter contains the information necessary to perform routine maintenance and occasional servicing tasks on your machine. The word “maintenance” refers to scheduled tasks that help your machine operate safely and effectively; “Service” refers to tasks that must be performed when a part needs to be repaired or replaced. For advanced service procedures, contact your Dealer.

A parts catalog is provided in the plastic manual case at the rear by the right header leg.

Log hours of operation and use the maintenance record provided (refer to [4.2.1 Maintenance Schedule/Record, page 568](#)) to keep track of your scheduled maintenance.

### 4.1 Preparing Machine for Servicing

Observe all safety precautions before beginning service on the machine.

#### DANGER

To prevent bodily injury or death from the unexpected start-up or fall of a raised machine, always stop the engine and remove the key before leaving the operator’s seat, and always engage the safety props before going under the machine for any reason.

#### CAUTION

To avoid personal injury, follow all the safety precautions listed before servicing header or opening drive covers.

#### DANGER

Ensure that all bystanders have cleared the area.

Before servicing the machine, follow these steps:

1. Lower the header fully.
2. Shut down the engine, and remove the key from the ignition.
3. Engage the park brake.
4. Wait for all of the moving parts to stop.

## 4.2 Maintenance Requirements

Regular maintenance is the best insurance against early wear and untimely breakdowns. Following the maintenance schedule will increase your machine’s life. Log hours of operation, use the maintenance record, and keep copies of your maintenance records (refer to [4.2.1 Maintenance Schedule/Record, page 568](#)).

Periodic maintenance requirements are organized according to service intervals. If a service interval specifies more than one timeframe, (e.g., 100 hours or annually), service the machine at whichever interval is reached first.

**IMPORTANT:**

The recommended intervals are for average conditions. Service the machine more often if you are operating the machine under adverse conditions (severe dust, extra heavy loads, etc.).




When servicing the machine, refer to the appropriate section in this chapter and use only the specified fluids and lubricants. Refer to the inside back cover for the recommended fluids and lubricants.

 **CAUTION**

Follow all safety messages. For instructions, refer to [1 Safety, page 1](#) and [4.1 Preparing Machine for Servicing, page 567](#).

### 4.2.1 Maintenance Schedule/Record

Recording maintenance allows the user to keep track of when maintenance is performed.

Action:		✓ – Check				◆ – Lubricate				▲ – Change			
	Hour meter reading												
	Service date												
	Serviced by												
<b>First Use</b>		Refer to <a href="#">4.2.2 Break-in Inspection, page 570</a> .											
<b>End of Season</b>		Refer to <a href="#">4.2.4 Equipment Servicing – End-of-Season, page 571</a> .											
<b>10 Hours or Daily (Whichever Occurs First)</b>													
✓	Hydraulic hoses and lines; refer to <a href="#">4.2.5 Checking Hydraulic Hoses and Lines, page 572</a> <sup>84</sup>												
✓	Knife sections, guards, and hold-downs; refer to <a href="#">4.8 Knife, page 629</a> <sup>84</sup>												
✓	Tire pressure; refer to <a href="#">4.16.3 Checking Tire Pressure, page 772</a> <sup>84</sup>												
◆	Feed draper rollers; refer to <a href="#">Every 10 Hours, page 574</a>												
✓	Link holder hooks; refer to <a href="#">4.10.7 Checking Link Holder Hooks, page 694</a> <sup>84</sup>												
✓	Axle bolt torque; refer to <a href="#">4.16.2 Checking Transport Assembly Bolt Torque, page 770</a>												
<b>25 Hours</b>													
✓	Hydraulic oil level at reservoir; refer to <a href="#">4.4.1 Checking Oil Level in Hydraulic Reservoir, page 595</a> <sup>84</sup>												
◆	Knifeheads; refer to <a href="#">Every 25 Hours, page 575</a> <sup>84</sup>												
<b>50 Hours or Annually</b>													
◆	Driveline and driveline universals; refer to <a href="#">Every 50 Hours, page 576</a>												
◆	Upper cross auger right bearing; refer to <a href="#">Every 50 Hours, page 576</a>												
◆	Upper cross auger sliding hubs; refer to <a href="#">Every 50 Hours, page 576</a>												

84. MacDon recommends keeping a record of daily maintenance as evidence of a properly maintained machine.





## MAINTENANCE AND SERVICING

Inspection Interval	Item	Refer to
10 Hours	Grease the feed draper bearings.	<i>Every 10 Hours, page 574</i>
50 Hours	Change the float module gearbox oil.	<i>Changing Oil in Header Drive Main Gearbox, page 590</i>
50 Hours	Change the float module hydraulic oil filter.	<i>4.4.4 Changing Oil Filter, page 597</i>
50 Hours	Change the knife drive box lubricant.	<i>Changing Oil in Knife Drive Box, page 667</i>
50 Hours	Check the gearbox chain tension.	<i>4.6.5 Adjusting Chain Tension – Main Gearbox, page 609 and 4.6.6 Adjusting Chain Tension – Completion Gearbox, page 610</i>

### 4.2.3 Equipment Servicing – Preseason

Equipment should be inspected and serviced at the beginning of each operating season.

#### CAUTION

- Review this manual to refresh your memory on the safety and operating recommendations.
  - Review all of the safety decals and the other decals on the header. Note the hazard areas.
  - Be sure all of the shields and guards are properly installed and secured. Never alter or remove safety equipment.
  - Be sure you understand and have practiced the safe use of all controls. Know the capacity and operating characteristics of the machine.
  - Ensure that you have a first aid kit and fire extinguisher. Know where they are and how to use them.
1. Lubricate the machine completely. For instructions, refer to *4.3 Lubrication, page 574*.
  2. Perform all annual maintenance tasks. For instructions, refer to *4.2.1 Maintenance Schedule/Record, page 568*.

### 4.2.4 Equipment Servicing – End-of-Season

Inspect and service the necessary equipment at the end of each operating season.

#### DANGER

Ensure that all bystanders have cleared the area.

#### WARNING

Never use gasoline, naphtha, or any volatile material for cleaning purposes. These materials may be toxic and/or flammable.

#### CAUTION

Cover the cutterbar and the knife guards to prevent injury from accidental contact.

## MAINTENANCE AND SERVICING

1. Clean the header thoroughly.
2. Store the header in a dry, protected place, if possible. If storing the header outdoors, cover the header with a waterproof canvas or another protective material.

### NOTE:

If you are storing the header outdoors, remove the drapers and store them in a dark, dry place. If you are **NOT** removing the drapers, lower the cutterbar so that water and snow cannot accumulate on the drapers. The weight of water and snow accumulating on the header puts significant stress on the drapers and the header frame.

3. Lower the header onto blocks to keep the cutterbar off of the ground.
4. Lower the reel completely. If you are storing the header outdoors, tie the reel to the frame to keep wind from rotating the wheel.
5. To prevent rust from forming on the header, repaint all worn or chipped painted surfaces.
6. Loosen the drive belts.
7. Lubricate the header thoroughly. Leave excess grease on the fittings to keep moisture out of the bearings.
8. Apply grease to the exposed threads, cylinder rods, and the sliding surfaces of components.
9. Lubricate the knife. Refer to the inside back cover for the recommended lubricants.
10. Check the header for broken components and order replacements from your Dealer. Immediately repairing these items will save time and effort at the beginning of the next season.
11. Tighten any loose hardware. For torque specifications, refer to Chapter *7.1 Torque Specifications, page 823*.

### 4.2.5 Checking Hydraulic Hoses and Lines

Check the hydraulic hoses and lines daily for signs of leaks.

#### DANGER

Ensure that all bystanders have cleared the area.

#### DANGER

To prevent bodily injury or death from the unexpected start-up of the machine, always stop the engine and remove the key from the ignition before making adjustments to the machine.

#### WARNING

- Avoid high-pressure fluids. Escaping fluid can penetrate the skin and cause serious injury.
- Before disconnecting hydraulic lines, relieve the pressure in the hydraulic system. Before adding pressure to the hydraulic system, tighten all of the system's connections.
- Keep your body away from pin holes and nozzles which can eject fluids under high pressure.
- If any fluid is injected into the skin, it must be surgically removed within a few hours by an experienced doctor or gangrene may develop.



Figure 4.1: Hydraulic Pressure Hazard

## MAINTENANCE AND SERVICING

- Use a piece of cardboard or paper to search for leaks.

### IMPORTANT:

Keep hydraulic coupler tips and connectors clean. Allowing dust, dirt, water, or foreign material to enter the hydraulic system is the major cause of hydraulic system damage. Do **NOT** attempt to service hydraulic systems in the field. Precise fits require a perfectly clean connection during overhaul.

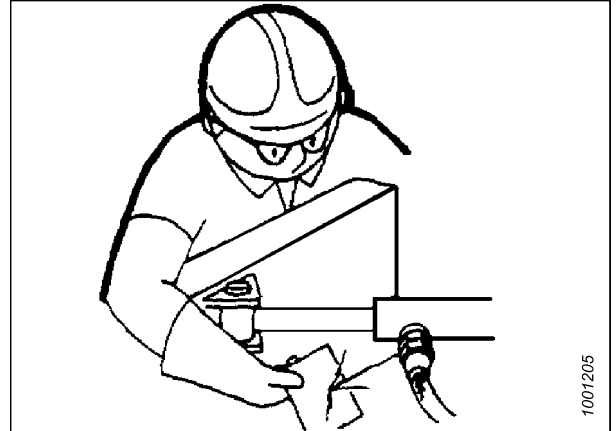


Figure 4.2: Testing for Hydraulic Leaks

1. Start the engine.
2. Engage the header. While it is running, raise and lower the header and the reel. Extend and retract the reel. Run it for 10 minutes.
3. Shut down the engine, and remove the key from the ignition.
4. Once the machine has been sitting still for several hours, walk around it and check for hoses, lines, or fittings that are visibly leaking oil.



## 4.3 Lubrication

Grease zerk locations are marked on the machine by decals showing a grease gun and the greasing interval, which will be specified in terms of hours of header operation.

Refer to the inside back cover for information on the recommended lubricants.

Log the header's hours of operation. Use the maintenance record provided in this manual to keep track of what maintenance procedures have been performed on the header, and when. For more information, refer to [4.2.1 Maintenance Schedule/Record, page 568](#).

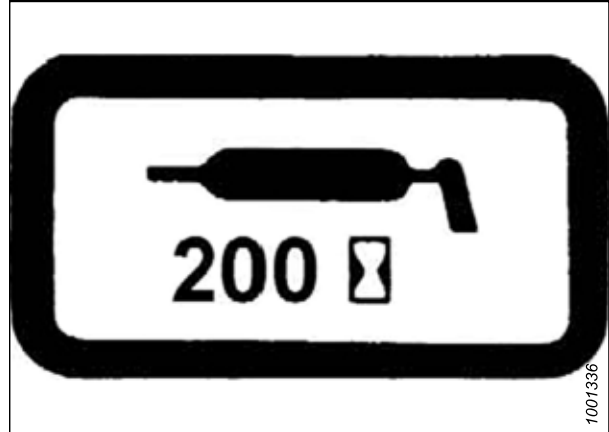


Figure 4.3: Grease Interval Decal

### 4.3.1 Lubrication Intervals

The lubrication intervals are specified in terms of hours of header operation. Maintaining accurate maintenance records is the best way to ensure that these procedures are performed in a timely fashion.

#### *Every 10 Hours*

Daily maintenance is required to keep your machine operating at peak performance. It also allows you to inspect the machine so that you can identify issues early.

Use high-temperature extreme-pressure (EP2) performance grease with 1% max. molybdenum disulphide (NLGI Grade 2) lithium base unless otherwise specified.

#### **IMPORTANT:**

When lubricating bearing (A), clear any debris and excess lubricant from around the bearing. Inspect the condition of the bearing and the bearing housing. Lubricate the bearing until grease comes out of the seal. Wipe any excess grease from the area after greasing.

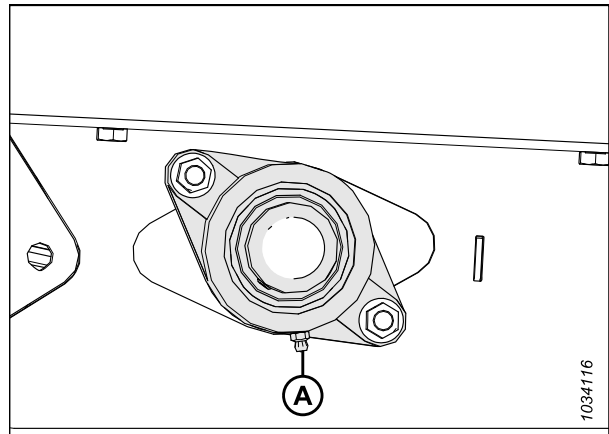


Figure 4.4: Feed Draper Drive Roller

## MAINTENANCE AND SERVICING

### IMPORTANT:

When lubricating bearing (A), clear any debris and excess grease from around the bearing housing. Inspect the condition of the roller and the bearing housing. Lubricate the bearing until grease comes out of the seal. The initial greasing on a new header may require an additional 5-10 pumps of grease. Wipe any excess grease from the area after greasing.

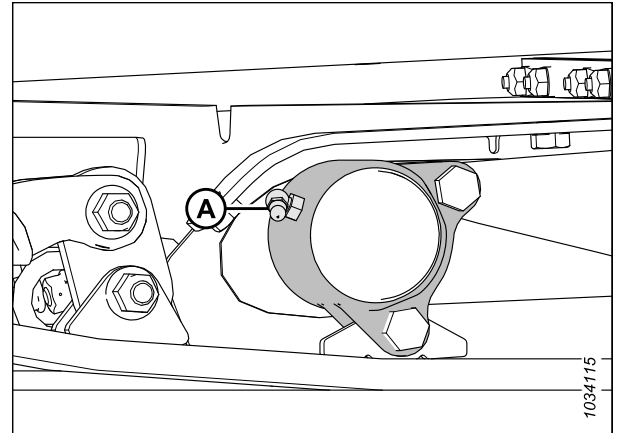


Figure 4.5: Feed Draper Idler Roller

### Every 25 Hours

Regular maintenance is required to keep your machine operating at peak performance. It also allows you to inspect the machine so that you can identify issues early.

Use high-temperature extreme-pressure (EP2) performance grease with 1% max. molybdenum disulphide (NLGI Grade 2) lithium base unless otherwise specified.

Lubricate knifehead (A) every 25 hours. After lubricating the knifehead, check for any signs of excessive heating on the first few guards. If it is required, relieve pressure on the knifehead by pressing the check-ball in the grease fitting.

### IMPORTANT:

Do **NOT** overgrease the knifehead. Overgreasing the knifehead puts pressure on the knife, causing it to rub against the guards, resulting in excessive wear from binding. Apply only one to two pumps of grease using a mechanical grease gun (do **NOT** use an electrical grease gun). If you require more than six to eight pumps of grease to fill the cavity, replace the seal in the knifehead. For instructions, refer to .

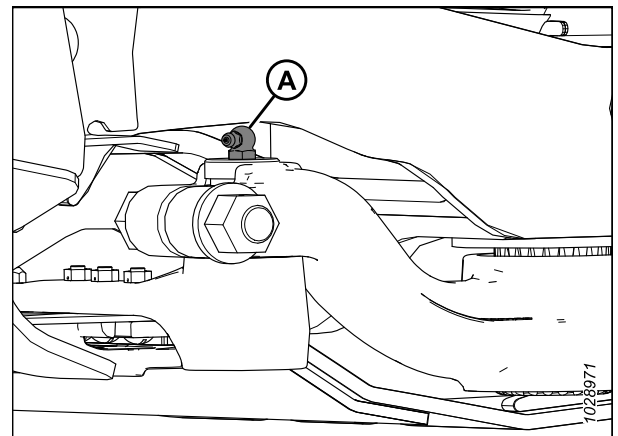
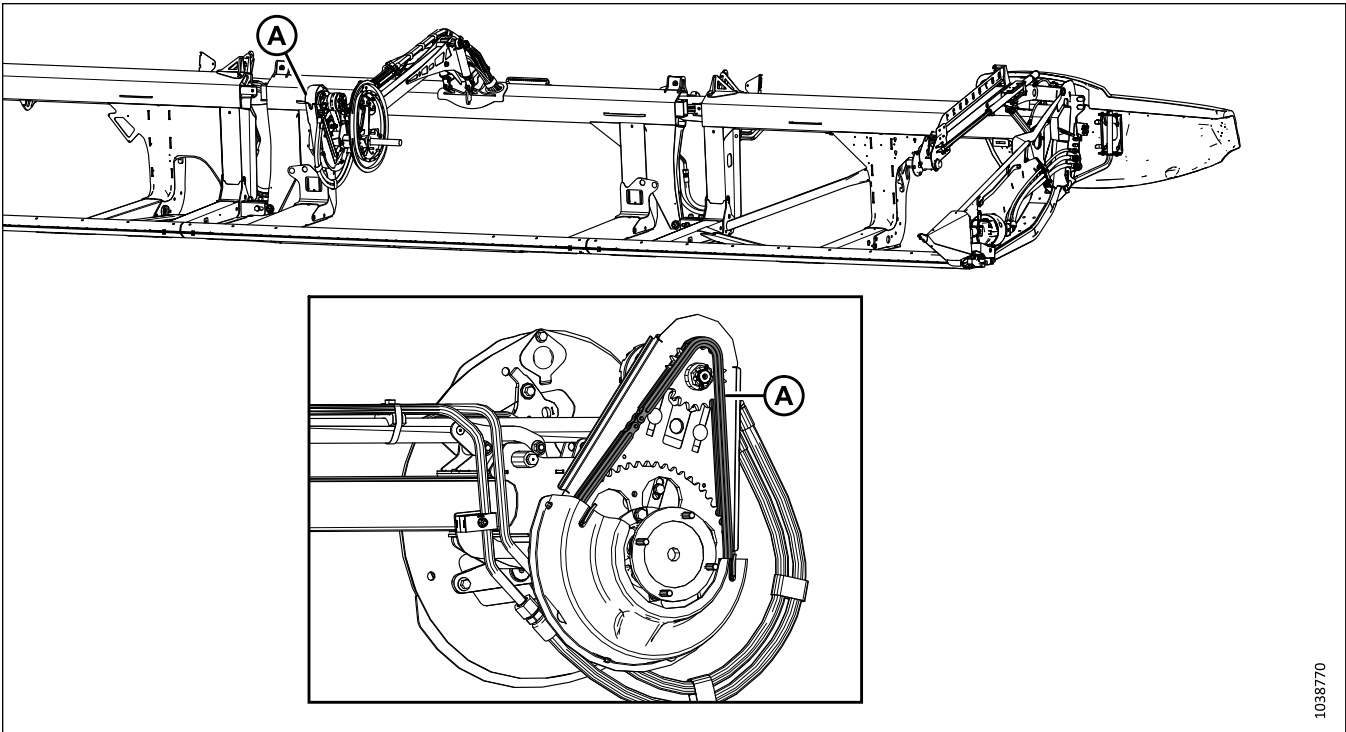


Figure 4.6: Knifehead

*Every 50 Hours*

Maintenance is required to keep your machine operating at peak performance. It also allows you to inspect the machine so that you can identify issues early.



**Figure 4.7: Reel**

A - Reel Drive Chain. To lubricate the chain, refer to [4.3.3 Lubricating Reel Drive Chain, page 587](#).

**IMPORTANT:**

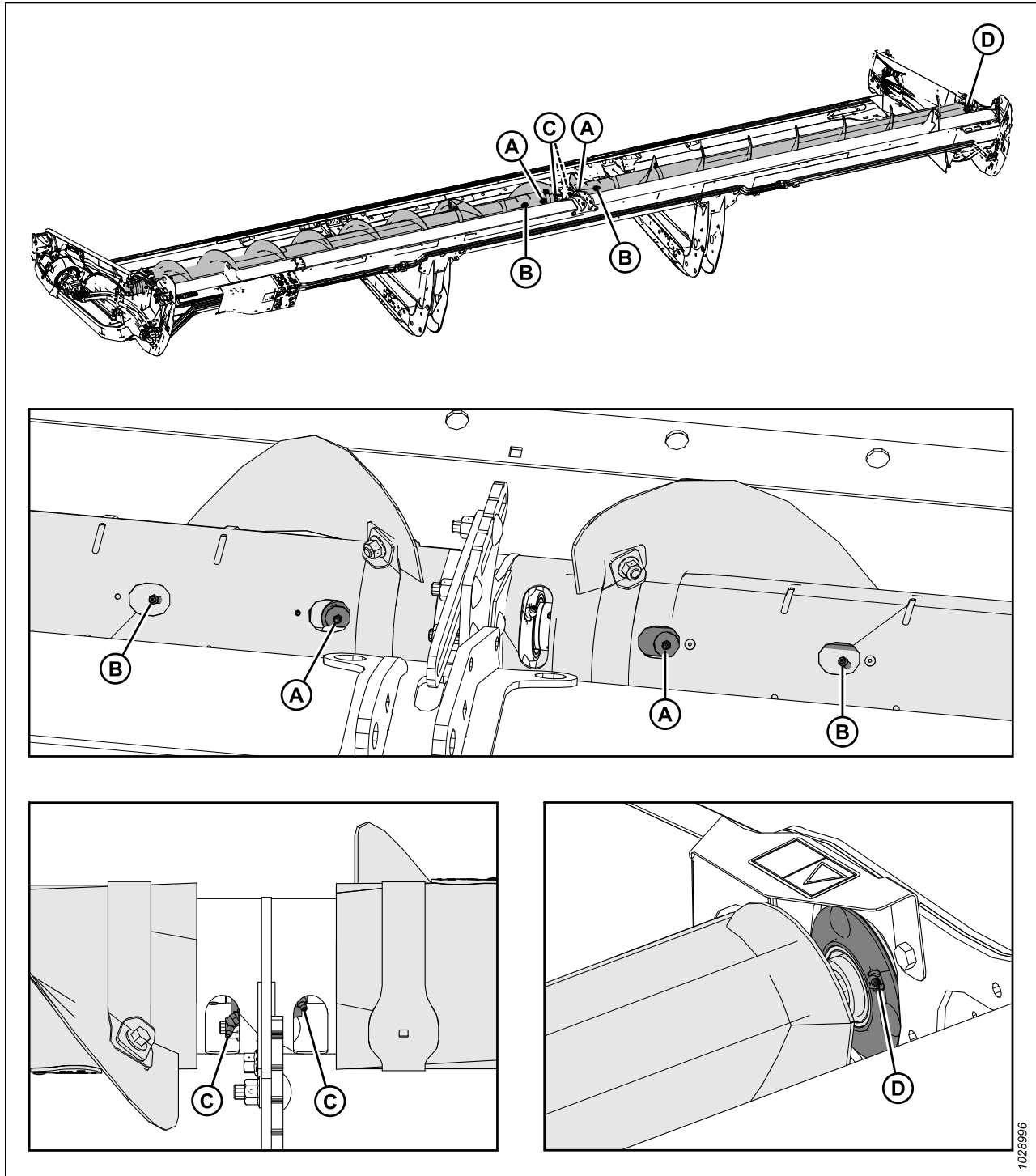
Use chain oil that has a viscosity of 100–150 cSt at 40°C (typically medium to heavy chain oil) or mineral oil Sae 20W50 that has no detergents or solvents.

**NOTE:**

If the chain is dry by the next oiling interval, lubricate it more often.

## MAINTENANCE AND SERVICING

Use high-temperature extreme-pressure (EP2) performance grease with 1% max. molybdenum disulphide (NLGI Grade 2) lithium base unless otherwise specified.



**Figure 4.8: Two-Piece Upper Cross Auger**

A - Upper Cross Auger U-joints (Two Places)

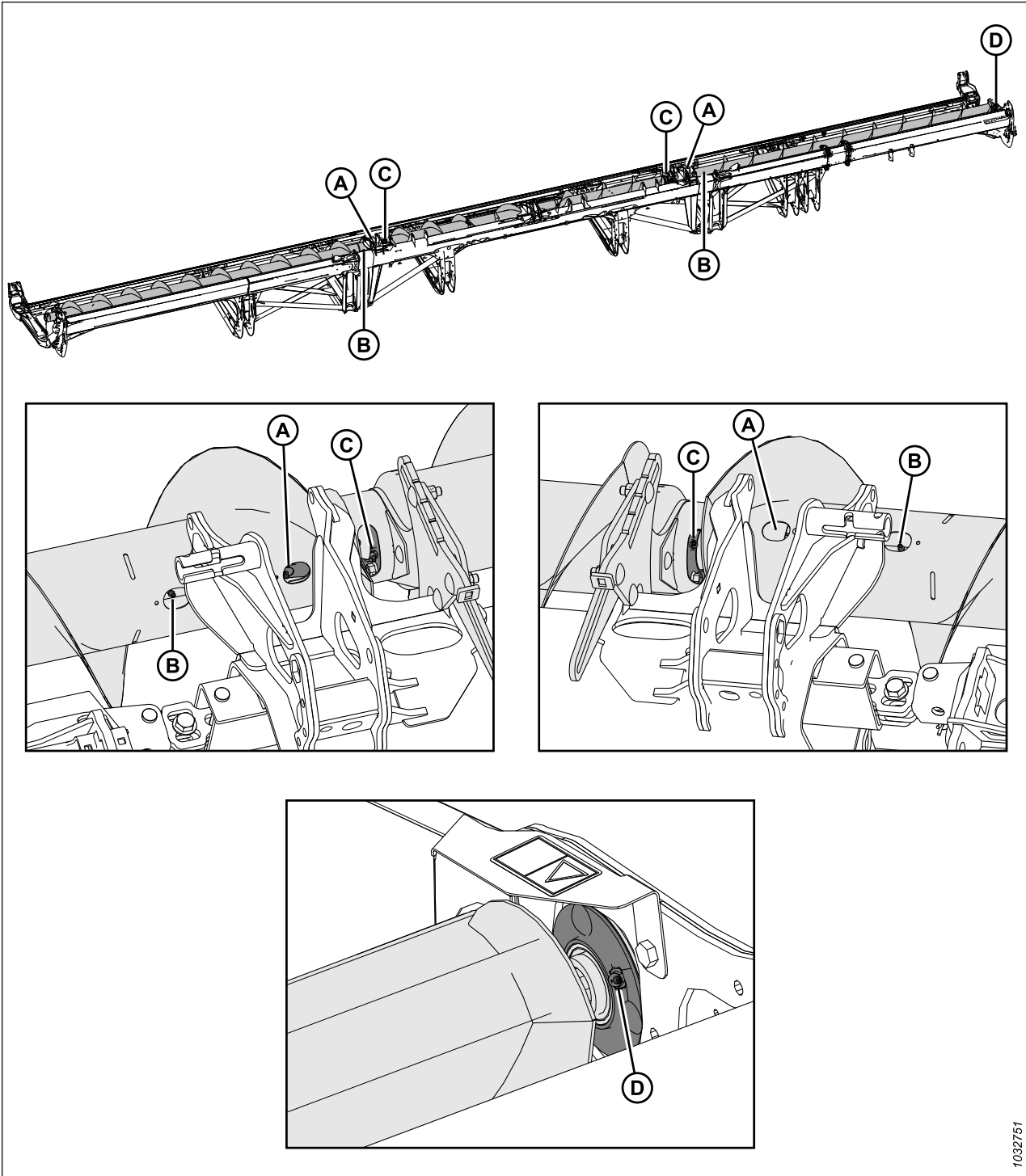
C - Upper Cross Auger Center Bearings (Two Places)

B - Upper Cross Auger Sliding Hubs (Two Places)

D - Right End Bearing

### IMPORTANT:

The upper cross auger (UCA) must be greased regularly even when it is turned off as components of the UCA move when the header flexes, regardless of whether the auger is turning or not.



1032751

**Figure 4.9: Three-Piece Upper Cross Auger**

A - Upper Cross Auger U-joints (Two Places)

C - Upper Cross Auger Center Bearings (Two Places)

B - Upper Cross Auger Sliding Hubs (Two Places)

D - Right End Bearing

**IMPORTANT:**

The upper cross auger (UCA) must be greased regularly even when it is turned off as components of the UCA move when the header flexes, regardless of whether the auger is turning or not.

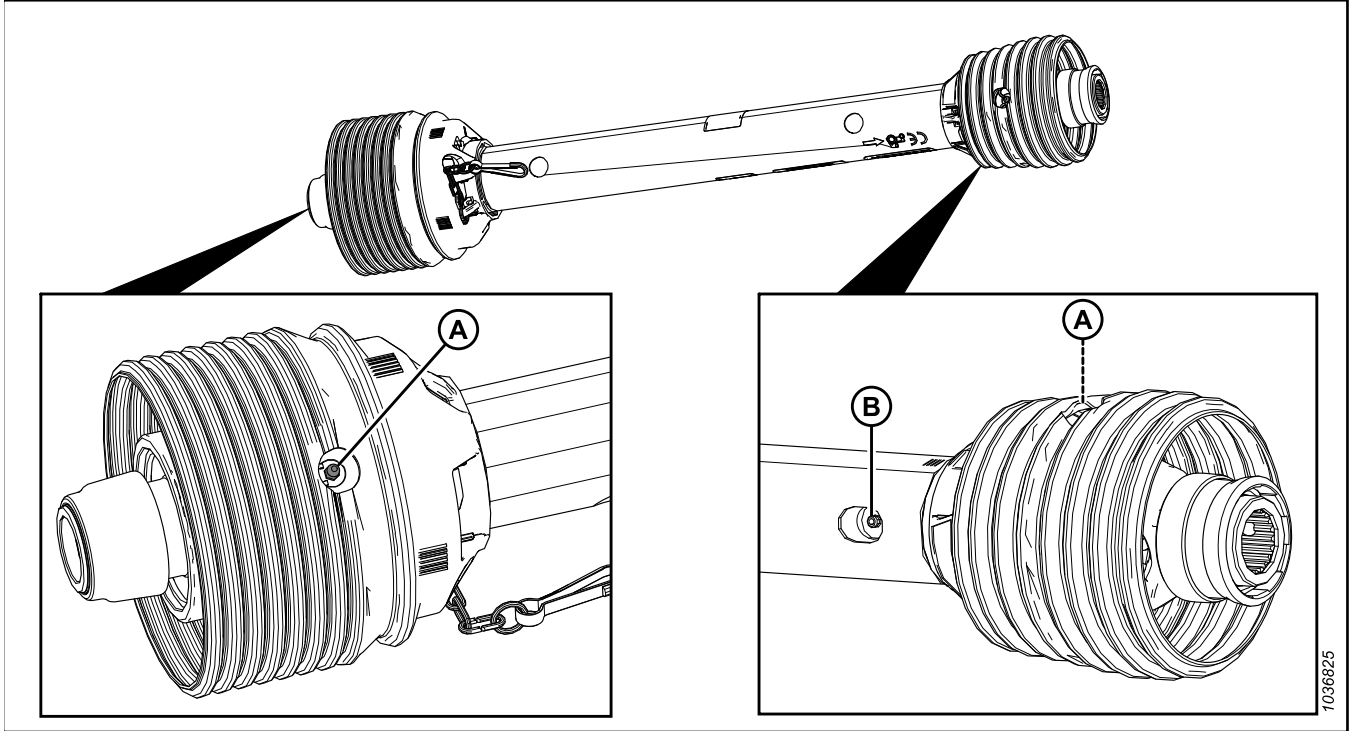


Figure 4.10: FM200

A - Driveline Universal (Two Places)

B - Driveline Slip Joint<sup>85</sup>

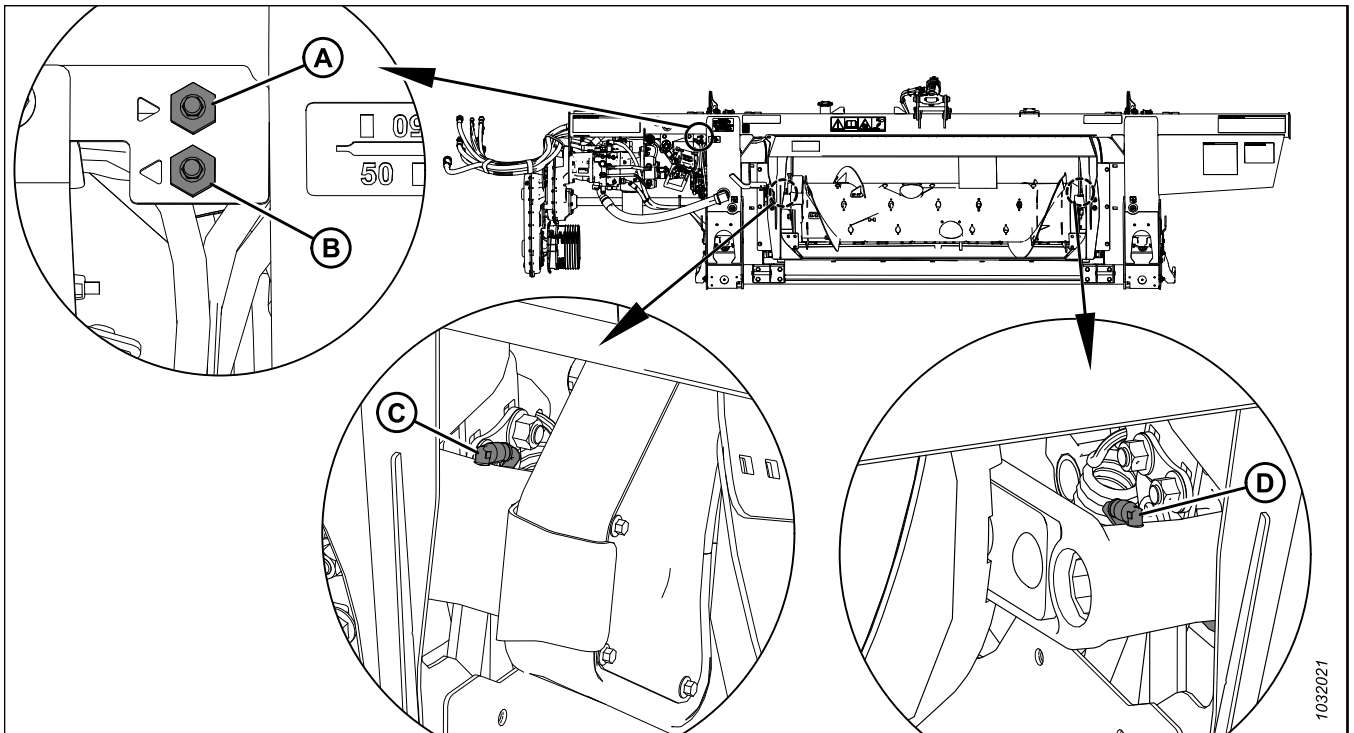


Figure 4.11: FM200

A - Remote Grease Line for Auger Pivot (Right Side)

B - Remote Grease Line for Auger Pivot (Left Side)

C - Auger Pivot (Left Side)

D - Auger Pivot (Right Side)

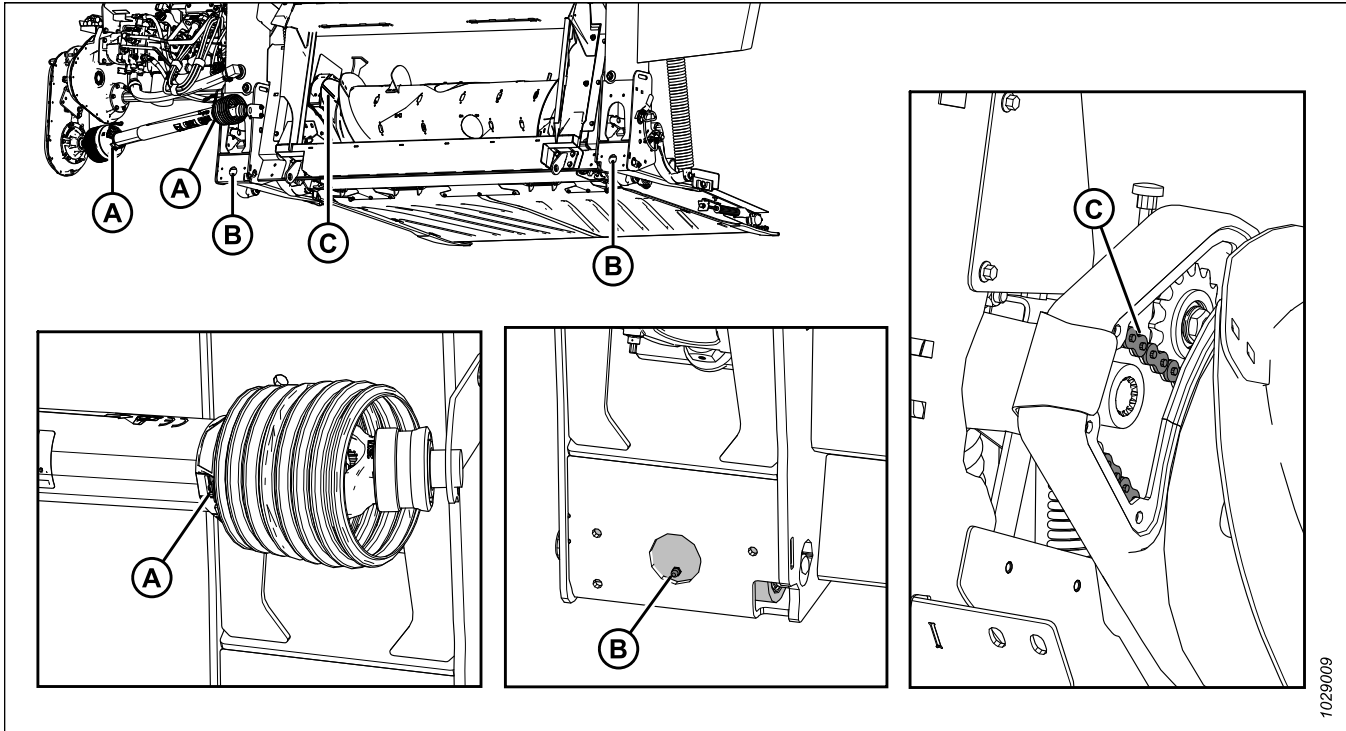
85. Use high-temperature extreme-pressure (EP2) performance grease with 10% max molybdenum disulphide (NLGI Grade 2) lithium base.

## MAINTENANCE AND SERVICING

### Every 100 Hours

Maintenance is required to keep your machine operating at peak performance. It also allows you to inspect the machine so that you can identify issues early.

Use high-temperature extreme-pressure (EP2) performance grease with 1% max. molybdenum disulphide (NLGI Grade 2) lithium base unless otherwise specified.



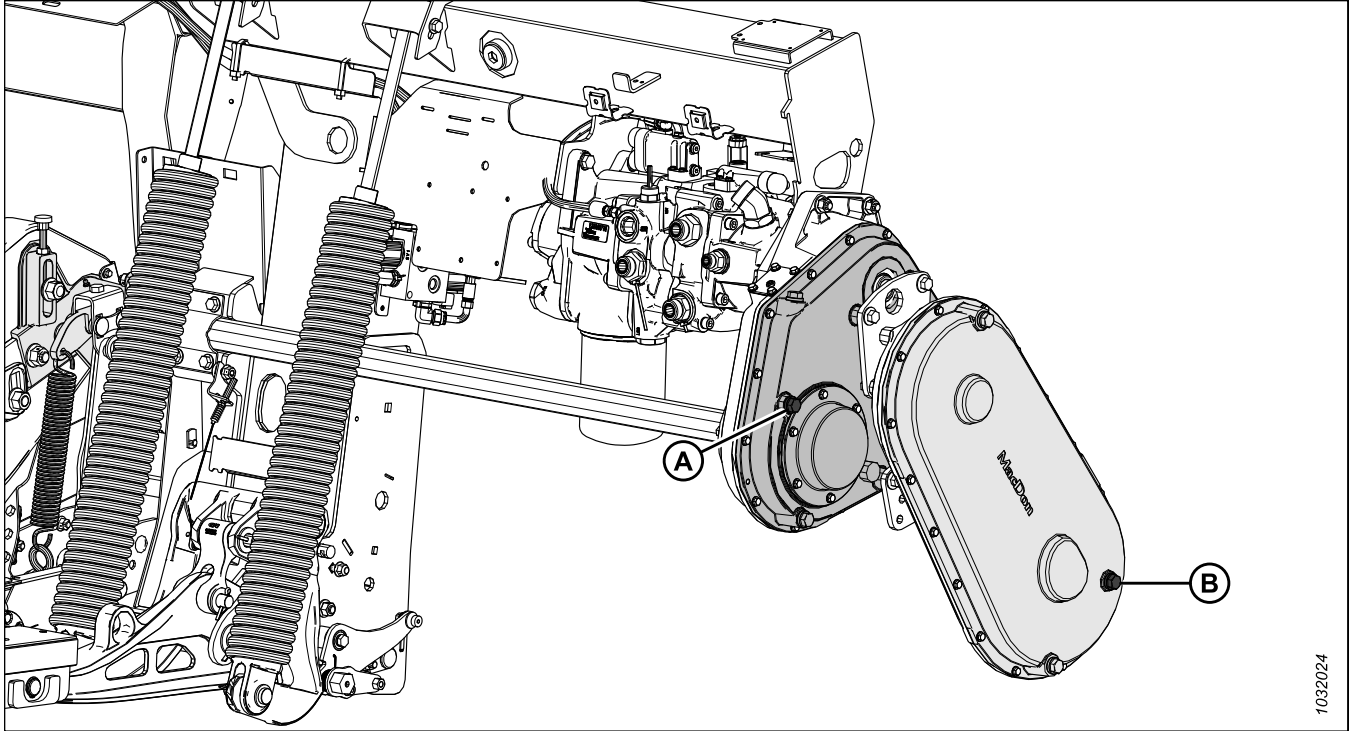
**Figure 4.12: FM200**

A - Driveline Guards (Both Ends)

B - Float Pivots (Right and Left)

C - Auger Drive Chain. To lubricate the chain, refer to [4.3.4 Lubricating Auger Drive Chain, page 587](#).



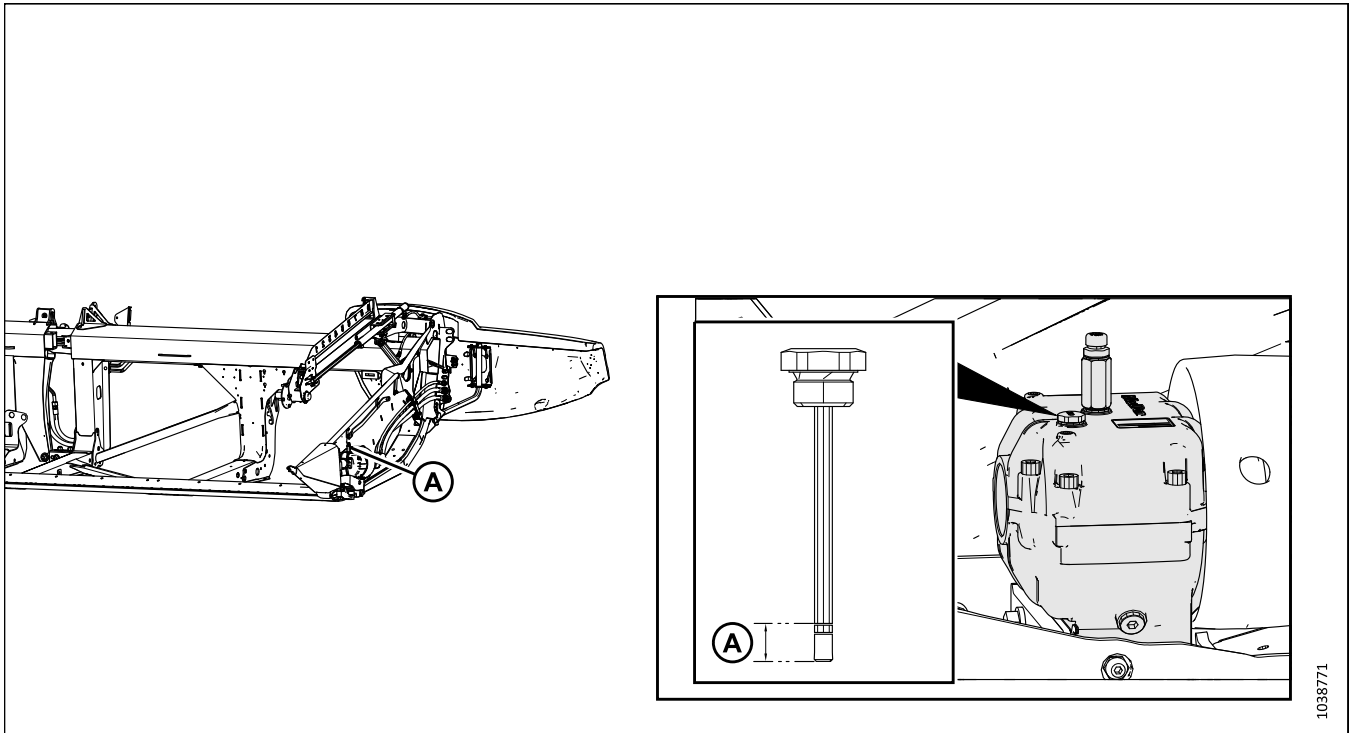


1032024

Figure 4.13: FM200

A - Main Gearbox Oil Level. To lubricate the main gearbox, refer to [4.3.5 Lubricating Header Drive Main Gearbox, page 589](#).

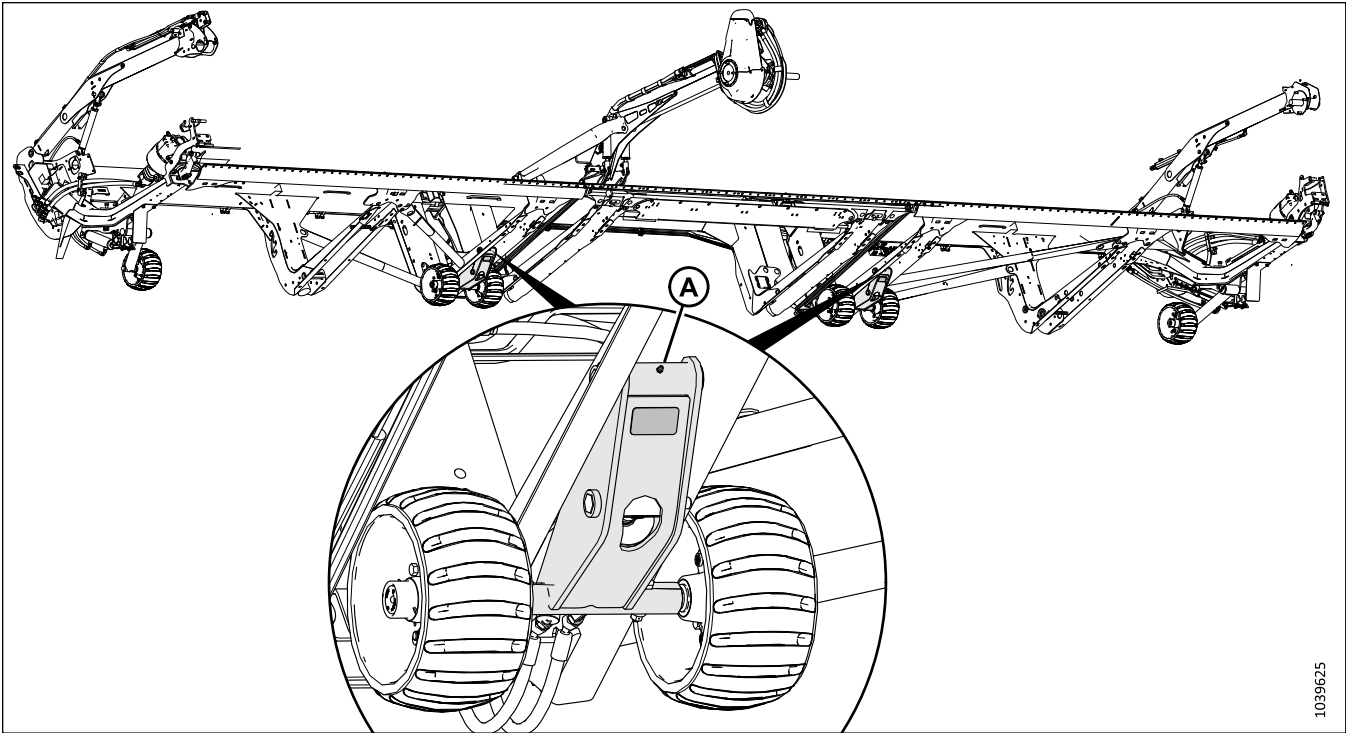
B - Completion Gearbox Oil Level. To lubricate the completion gearbox, refer to [4.3.6 Lubricating Header Drive Completion Gearbox, page 591](#).



1038771

Figure 4.14: Knife Drive Box

A - Knife Drive Box Oil Level. To lubricate the knife drive box, refer to [Checking Oil Level in Knife Drive Box, page 666](#).



1039625

**Figure 4.15: Inner Contour Wheel Assemblies**

A - Inner Wheel Assemblies (Two Places)

### *Every 250 Hours*

Maintenance is required to keep your machine operating at peak performance. It also allows you to inspect the machine so that you can identify issues early.

Use high-temperature extreme-pressure (EP2) performance grease with 1% max. molybdenum disulphide (NLGI Grade 2) lithium base unless otherwise specified.

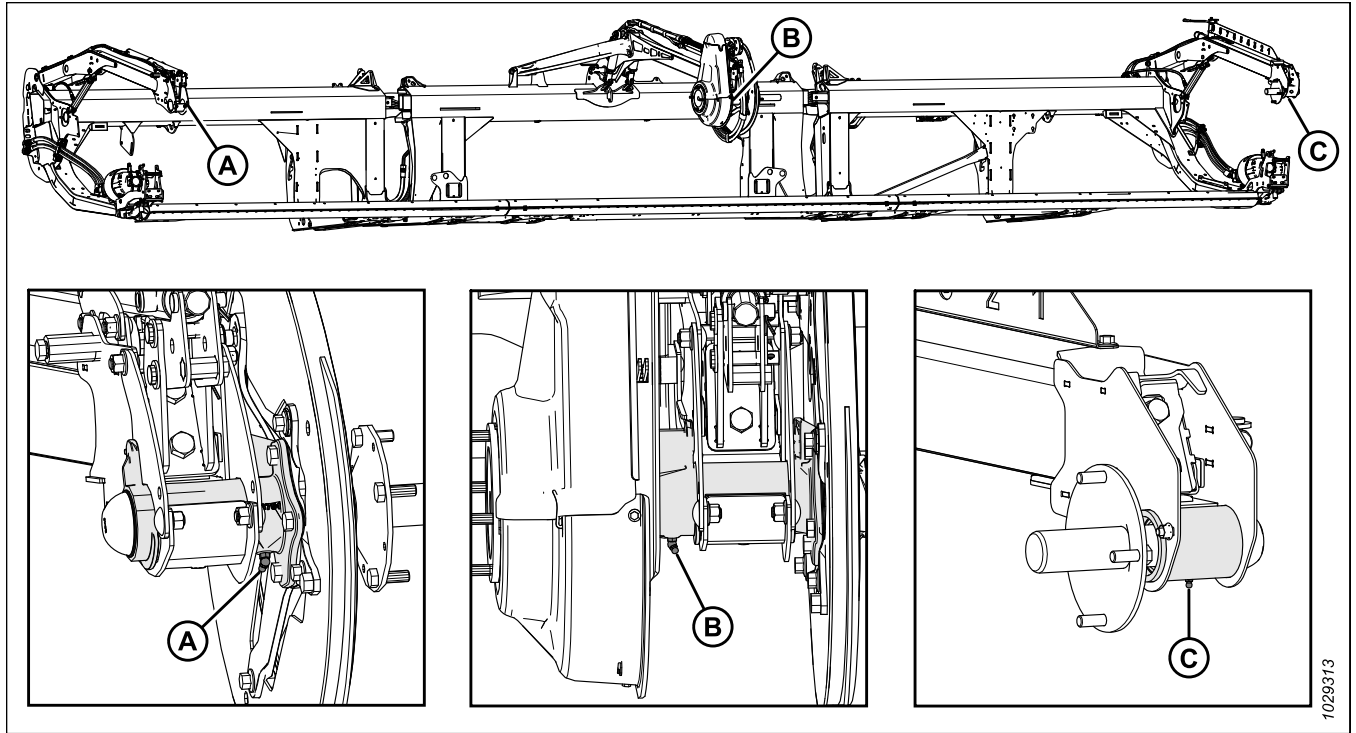


Figure 4.16: Reel

A - Reel Right Bearing (One Place)

B - Reel Center Bearing (One Place)

C - Reel Left Bearing (One Place)

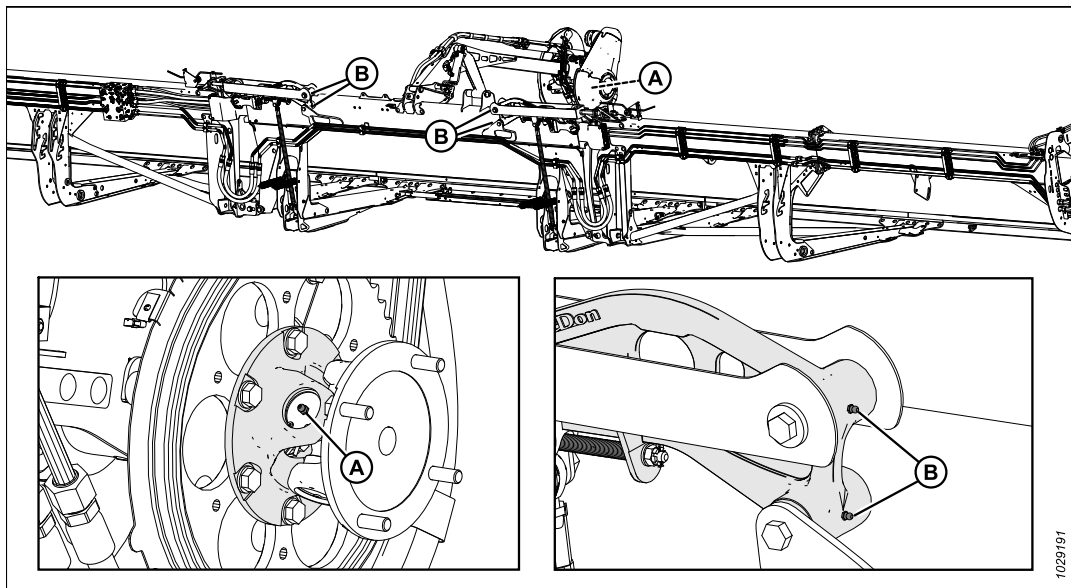


Figure 4.17: Reel

A - Reel U-joint (One Place)<sup>86</sup>

B - Flex Linkage (Two Places) – Both Sides

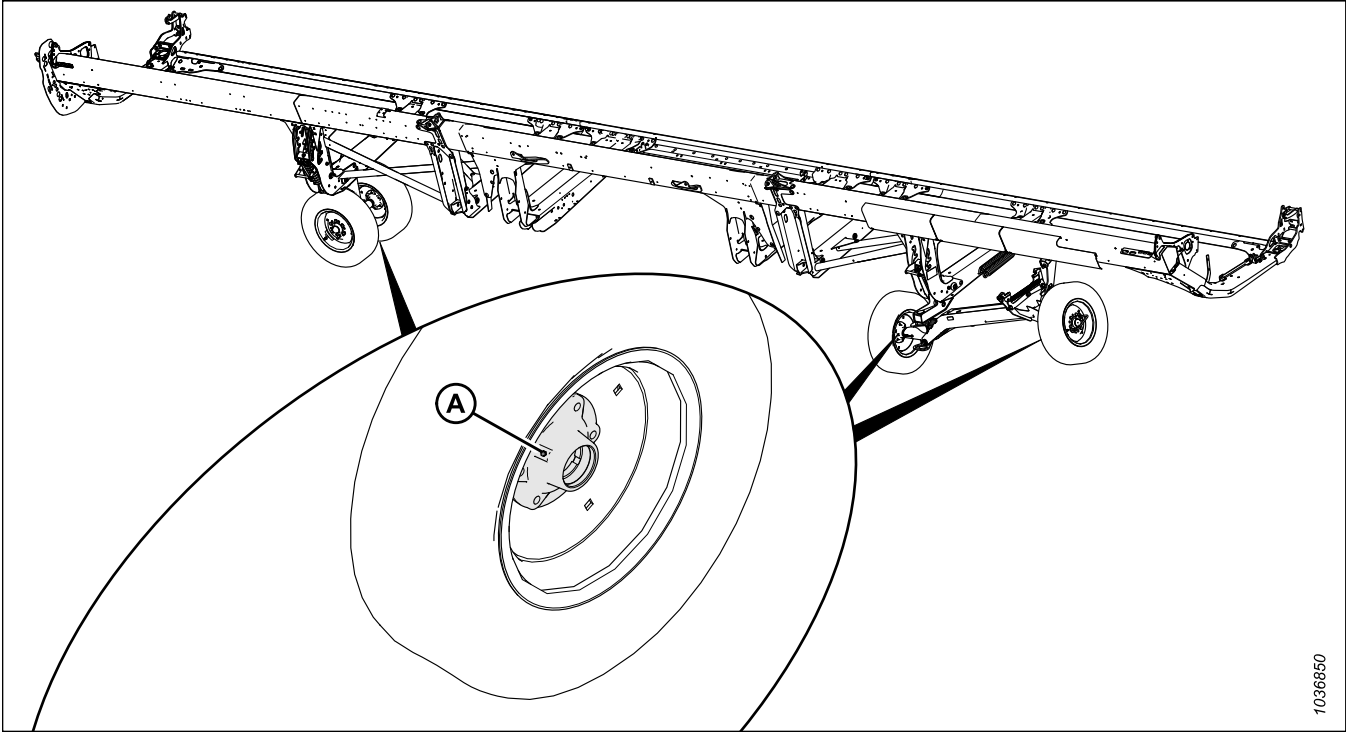
86. The U-joint has an extended lubrication cross and bearing kit. Stop greasing the U-joint when greasing becomes difficult or if it stops taking grease. Overgreasing the U-joint will damage it. Six to eight pumps are sufficient for the first greasing. Grease the U-joint more frequently as it wears down and requires more than six pumps.

## MAINTENANCE AND SERVICING

### *Every 500 Hours*

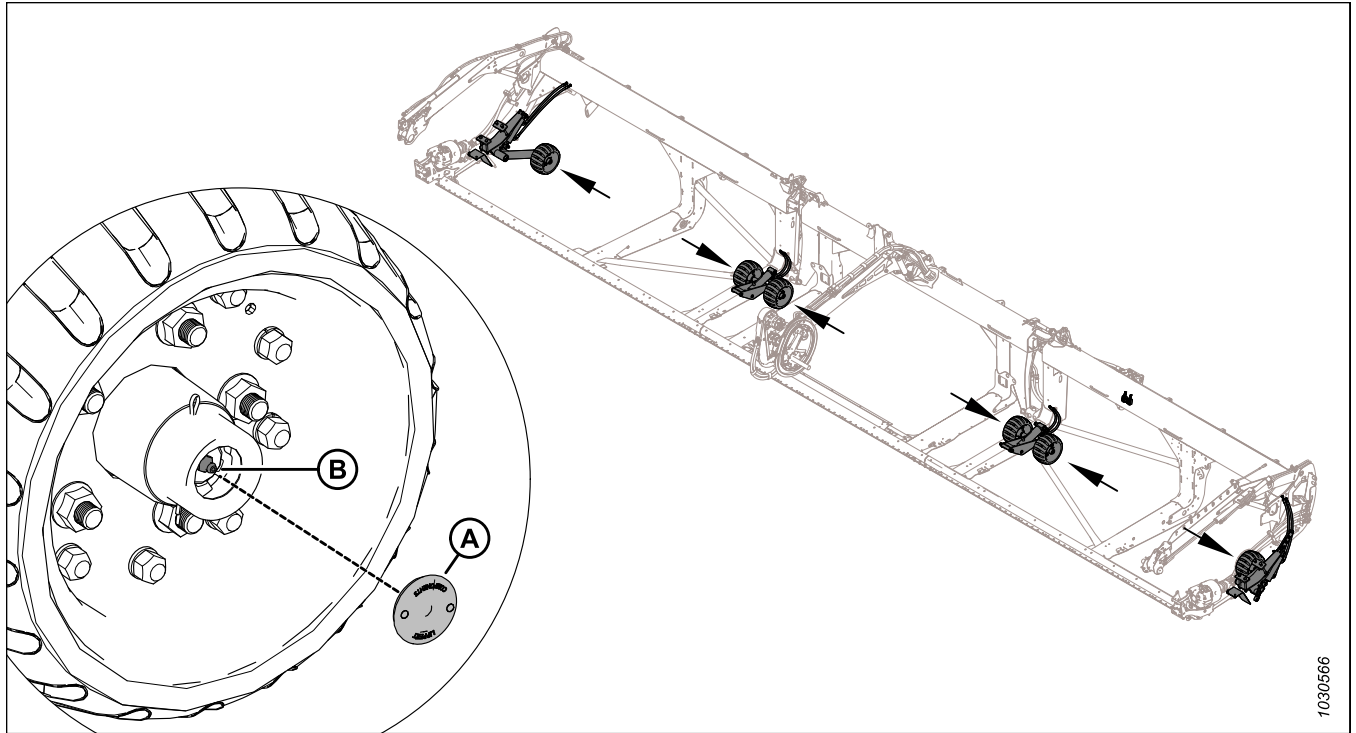
Maintenance is required to keep your machine operating at peak performance. It also allows you to inspect the machine so that you can identify issues early.

Use high temperature extreme pressure (EP2) performance grease with 1% max. molybdenum disulphide (NLGI Grade 2) lithium base unless otherwise specified.



**Figure 4.18: Wheel Bearings**

A - Wheel Bearings (Four Places)



**Figure 4.19: Contour Wheel Bearings**

**B - Wheel Bearings (Six Places)**

Lubricate the bearings on all six contour wheels as follows:

1. Remove rubber plug (A) from the contour wheel hub. Retain the plug for reinstallation.
2. Apply grease at lubrication point (B), and allow the excess grease to flow out the front of the axle hub.

**IMPORTANT:**

Grease the lubrication point **SLOWLY**. Rapid greasing may force the rear seal to move.

3. Reinstall rubber plug (A).

### 4.3.2 Greasing Procedure

Greasing points are identified on the machine by decals showing a grease gun and grease interval in hours of operation. Grease point layout decals are located on the header and on the right side of the float module.

**⚠ DANGER**

To prevent injury or death from the unexpected start-up of the machine, always stop the engine and remove the key from the ignition before leaving the operator's seat for any reason.

## MAINTENANCE AND SERVICING

Refer to the inside back cover for the recommended lubricants.

Log hours of operation and use the Maintenance Record provided to keep a record of scheduled maintenance; refer to [4.2.1 Maintenance Schedule/Record, page 568](#).

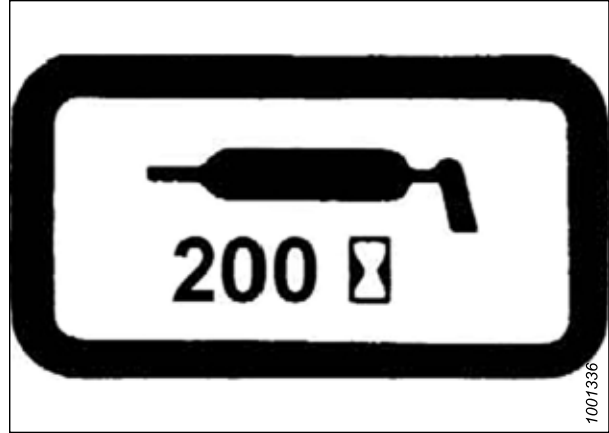


Figure 4.20: Greasing Interval Decal

1. Before lubricating a grease fitting, wipe it with a clean cloth to avoid injecting dirt and grit into the fitting.

**IMPORTANT:**

Use clean, high-temperature, extreme-pressure grease only.

2. Inject the grease through the fitting with a grease gun until the grease overflows the fitting (except where noted).
3. Leave the excess grease on the fitting to keep the dirt out.
4. Replace any loose or broken grease fittings immediately.
5. Remove and thoroughly clean any fitting that will not take grease. Clean the lubricant passageway. Replace the fitting if necessary.

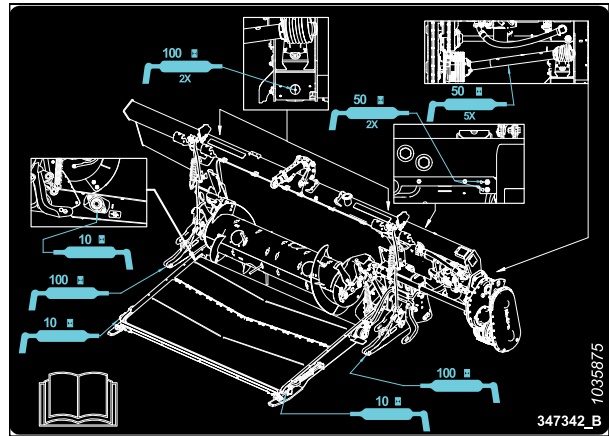


Figure 4.21: FM200 Grease Point Layout Decal

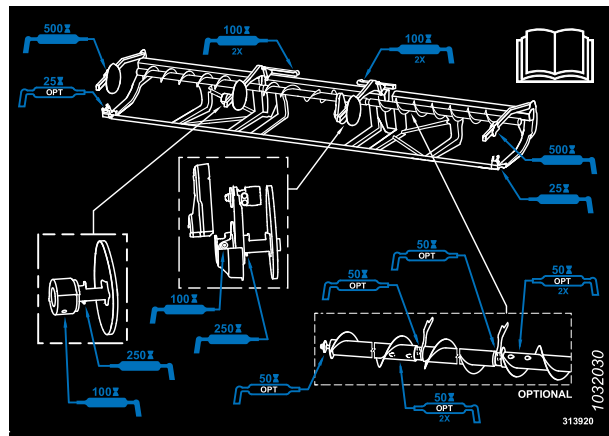


Figure 4.22: FD2 Series Grease Point Layout Decal

### 4.3.3 Lubricating Reel Drive Chain

Lubrication protects the chain and the drive sprockets against wear.

#### DANGER

To prevent injury or death from the unexpected start-up of the machine, always stop the engine and remove the key from the ignition before leaving the operator's seat for any reason.

#### DANGER

Ensure that all bystanders have cleared the area.

#### IMPORTANT:

Do **NOT** use grease or motor oils to lubricate the reel drive chain.

1. Remove the reel drive cover. For instructions, refer to [Removing Reel Drive Cover, page 49](#).

#### IMPORTANT:

Use a chain oil with a viscosity of 100–150 cSt at 40°C (104°F) (typically medium to heavy chain oil) or a mineral oil (SAE 20W50) that has no detergents or solvents.

2. Apply a liberal amount of chain oil to inside of chain (A) with an oil can, brush, or aerosol. Manually rotate the reel to lubricate the chain.
3. Reinstall the reel drive cover. For instructions, refer to [Installing Reel Drive Cover, page 51](#).
4. Start the engine. For instructions, refer to the combine operator's manual.
5. Run the header and the reel for a few minutes so that the oil spreads into the chain.

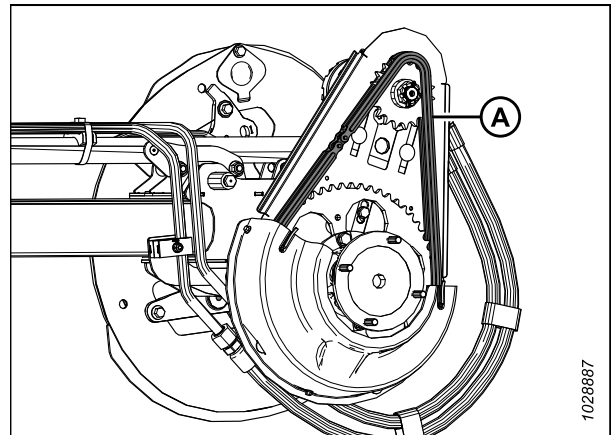


Figure 4.23: Drive Chain

### 4.3.4 Lubricating Auger Drive Chain

Lubricate the auger drive chain according to the interval specified in the maintenance schedule.

#### NOTE:

You can lubricate the auger drive chain with the float module attached to the combine, but this procedure is easier to perform when the float module is detached from the header.

#### DANGER

To prevent injury or death from the unexpected start-up of the machine, always stop the engine and remove the key from the ignition before leaving the operator's seat for any reason.

The auger drive cover consists of an upper cover, a lower cover, and a metal inspection panel. Only the metal inspection panel needs to be removed to perform this procedure.

1. Shut down the engine, and remove the key from the ignition.



## MAINTENANCE AND SERVICING

2. Remove four bolts (A) and metal inspection panel (B). Retain the bolts.

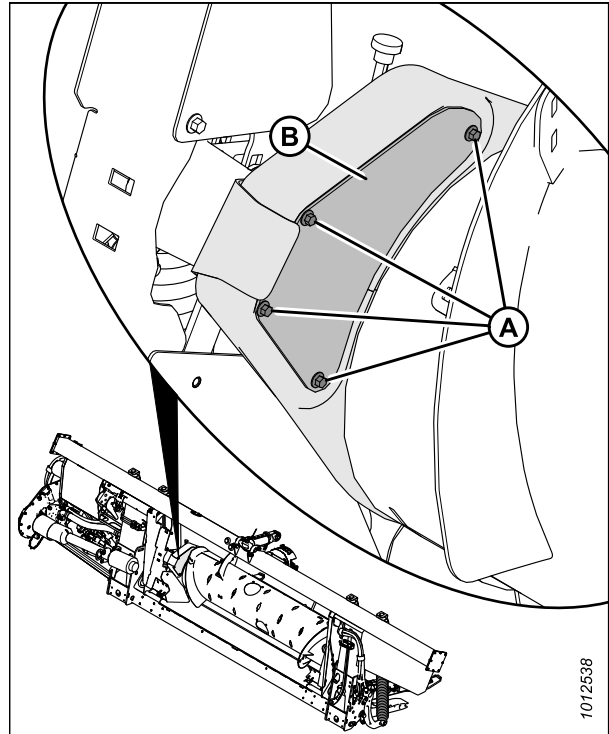


Figure 4.24: Auger Drive Inspection Panel

3. Apply a liberal amount of grease to chain (A), drive sprocket (B), and idler sprocket (C).
4. Rotate the auger and apply grease to more areas of the chain, if necessary.

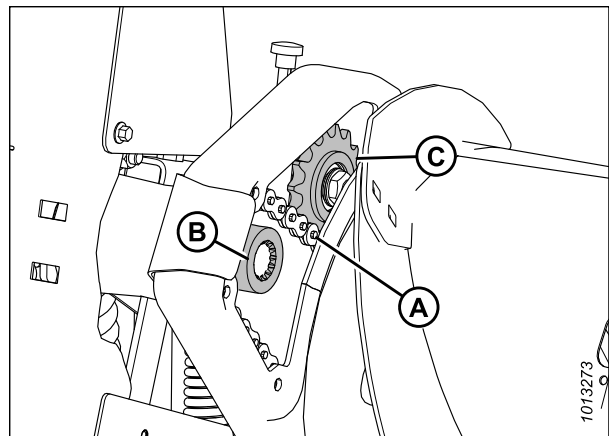


Figure 4.25: Auger Drive Chain

5. Reinstall metal inspection panel (B). Secure the panel with four bolts (A).

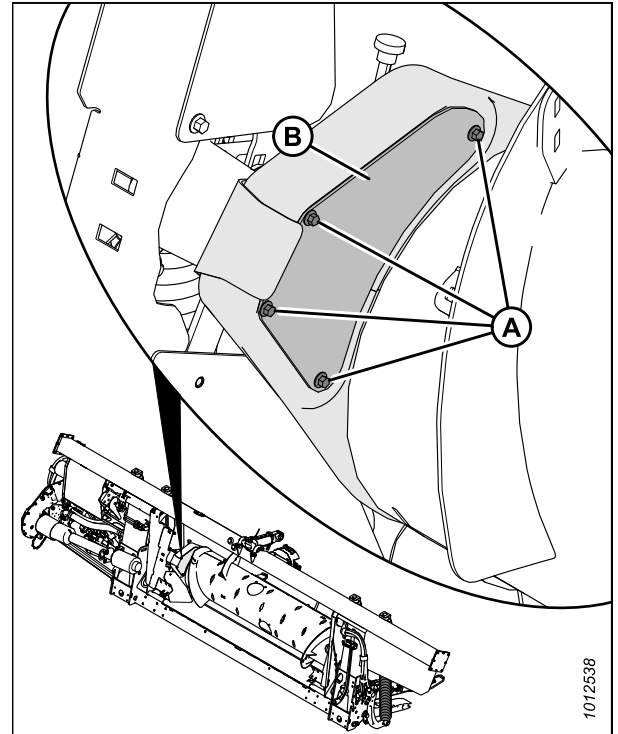


Figure 4.26: Auger Drive Inspection Panel

### 4.3.5 Lubricating Header Drive Main Gearbox

#### *Checking Oil Level in Header Drive Main Gearbox*

Check the header drive gearbox oil level every 100 hours.

 **DANGER**

To prevent injury or death from the unexpected start-up of the machine, always stop the engine and remove the key from the ignition before leaving the operator's seat for any reason.

 **DANGER**

Ensure that all bystanders have cleared the area.

1. Lower the header fully.
2. Shut down the engine, and remove the key from the ignition.

## MAINTENANCE AND SERVICING

3. Remove oil level plug (A) from main gearbox (B) and ensure that the oil level is up to the bottom of the hole.
4. Add oil if required. For instructions, refer to [Adding Oil to Header Drive Main Gearbox, page 590](#).
5. Reinstall oil level plug (A).

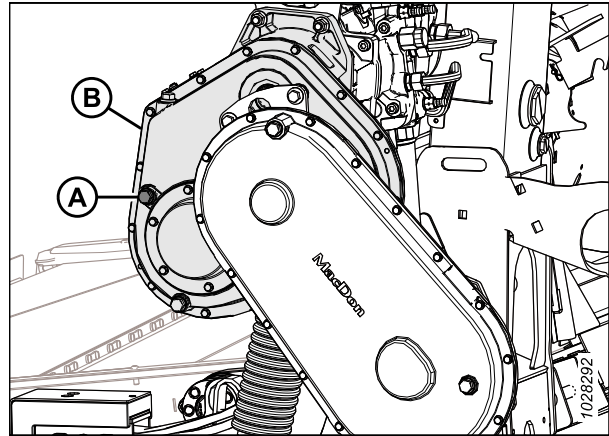


Figure 4.27: Header Drive Main Gearbox

### *Adding Oil to Header Drive Main Gearbox*

The main gearbox includes fill, check, and drain plugs for quickly checking and servicing the gear lubricant while it is mounted to the float module.

#### **DANGER**

To prevent injury or death from the unexpected start-up of the machine, always stop the engine and remove the key from the ignition before leaving the operator's seat for any reason.

1. Shut down the engine, and remove the key from the ignition.
2. Remove filler plug (B) and oil level plug (A) from the main gearbox.
3. Add oil into filler plug hole (B) until it runs out of oil level plug hole (A). Refer to the inside back cover for recommended fluids and lubricants.
4. Replace oil level plug (A) and filler plug (B).

#### **NOTE:**

The oil drain plug is magnetic. Ensure that the magnetic plug is installed in the oil drain position.

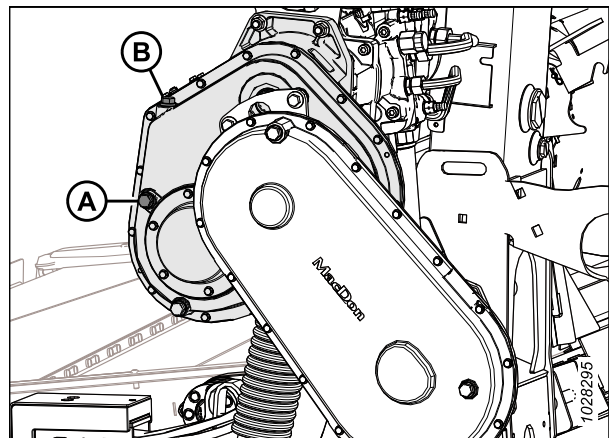


Figure 4.28: Header Drive Main Gearbox

### *Changing Oil in Header Drive Main Gearbox*

Change the header drive gearbox oil after the first 50 hours of operation and every 1000 hours (or 3 years) thereafter.

#### **DANGER**

To prevent injury or death from the unexpected start-up of the machine, always stop the engine and remove the key from the ignition before leaving the operator's seat for any reason.

#### **WARNING**

Ensure that all bystanders have cleared the area.

## MAINTENANCE AND SERVICING

1. Start the engine.
2. Engage the header to warm up the oil.
3. Raise or lower the header to position oil drain plug (A) at its lowest point.
4. Shut down the engine, and remove the key from the ignition.
5. Place a suitable container (approximately 4 liters [1 US gal]) underneath the gearbox drain to collect the oil.
6. Remove oil drain plug (A) and filler plug (C).
7. Let the oil drain.
8. Replace oil drain plug (A) and remove oil level plug (B).
9. Add the oil through filler plug hole (C) until the oil runs out of oil level hole (B). Refer to the inside back cover for the recommended lubricants.

### NOTE:

The main gearbox holds approximately 2.75 liters (2.9 quarts) of oil.

10. Replace oil level plug (B) and filler plug (C).

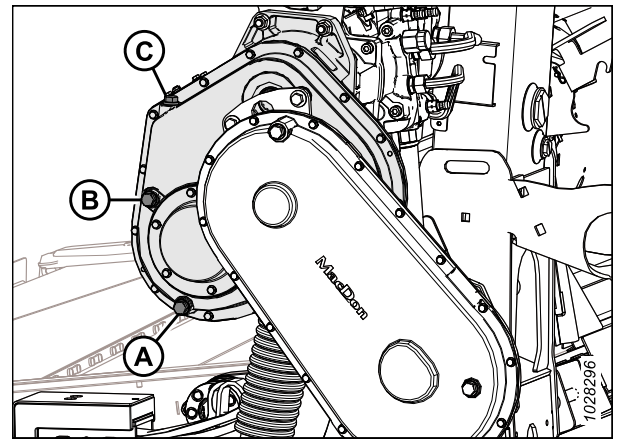


Figure 4.29: Header Drive Main Gearbox

### 4.3.6 Lubricating Header Drive Completion Gearbox

#### *Checking Oil Level in Header Drive Completion Gearbox*

Check the header drive gearbox oil level every 100 hours.

### DANGER

To prevent injury or death from the unexpected start-up of the machine, always stop the engine and remove the key from the ignition before leaving the operator's seat for any reason.

### DANGER

Ensure that all bystanders have cleared the area.

1. Lower the header fully.
2. Shut down the engine, and remove the key from the ignition.

## MAINTENANCE AND SERVICING

3. Remove oil level plug (A) from the completion gearbox. The oil should be at the level of the port.
4. If there is an insufficient amount of oil in the completion gearbox, remove filler plug (B) and add oil. For instructions, refer to [Adding Oil to Header Drive Completion Gearbox](#), page 592.
5. Reinstall oil level plug (A).

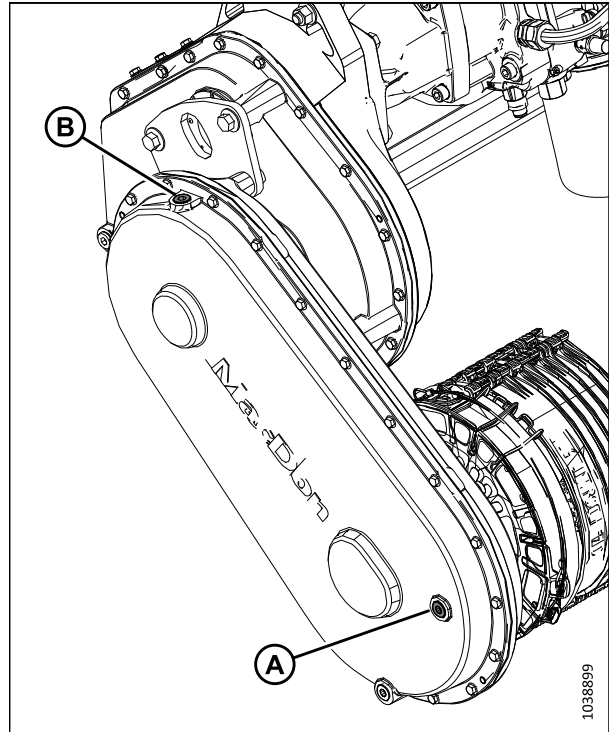


Figure 4.30: Header Drive Completion Gearbox

### *Adding Oil to Header Drive Completion Gearbox*

The completion gearbox includes fill, check, and drain plugs for quickly checking and servicing the gear lubricant while it is mounted to the float module.

#### **DANGER**

To prevent injury or death from the unexpected start-up of the machine, always stop the engine and remove the key from the ignition before leaving the operator's seat for any reason.

#### **DANGER**

Ensure that all bystanders have cleared the area.

1. Lower the cutterbar to the ground and ensure that the completion gearbox is in working position.
2. Shut down the engine, and remove the key from the ignition.

## MAINTENANCE AND SERVICING

3. Remove filler plug (B) and oil level plug (A).
4. Add oil into filler hole (B) until the oil runs out of hole (A). Refer to the inside back cover for the recommended fluids and lubricants.
5. Reinstall oil level plug (A) and filler plug (B). Torque the plugs to 30–40 Nm (22–30 lbf·ft).

**NOTE:**

The oil drain plug is magnetic. Ensure that the magnetic plug is installed in the oil drain position.

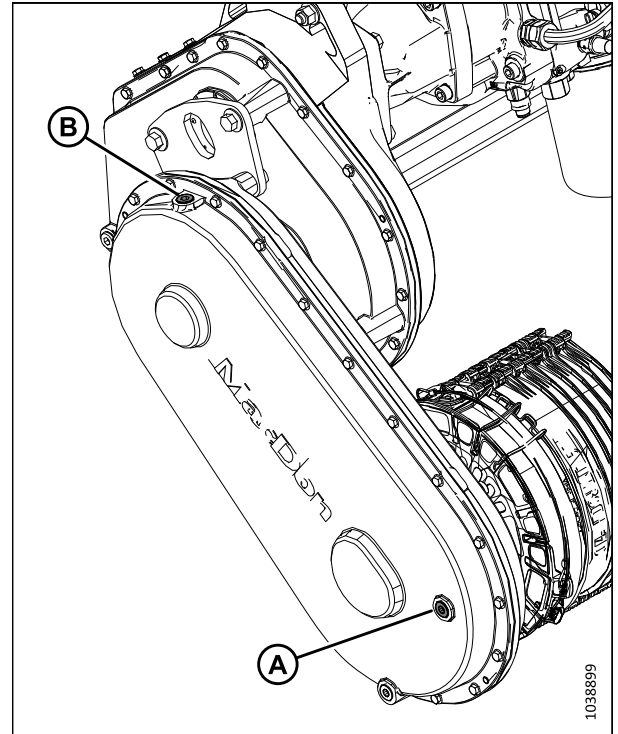


Figure 4.31: Header Drive Completion Gearbox

### *Changing Oil in Header Drive Completion Gearbox*

Change the header drive gearbox oil after the first 50 hours of operation and every 1000 hours (or 3 years) thereafter.

**⚠ DANGER**

To prevent injury or death from the unexpected start-up of the machine, always stop the engine and remove the key from the ignition before leaving the operator's seat for any reason.

**⚠ DANGER**

Ensure that all bystanders have cleared the area.

1. Engage the header to warm up the oil.

## MAINTENANCE AND SERVICING

2. Raise or lower the header to position oil drain plug (A) at its lowest point.
3. Shut down the engine, and remove the key from the ignition.
4. Place a suitable container (approximately 4 liters [1 US gal]) underneath the gearbox drain to collect the oil.
5. Remove oil drain plug (A) and filler plug (C).
6. Let the oil drain.
7. Reinstall oil drain plug (A).

### IMPORTANT:

The oil drain plug is magnetic. Ensure that the magnetic plug is installed in oil drain position (A).

8. Remove oil level plug (B).
9. Add the oil through filler plug hole (C) until the oil runs out of oil level hole (B). Refer to the inside back cover for the recommended lubricants.

### NOTE:

The header drive gearbox holds approximately 2.25 liters (2.4 quarts) of oil.

10. Reinstall oil level plug (B) and filler plug (C).

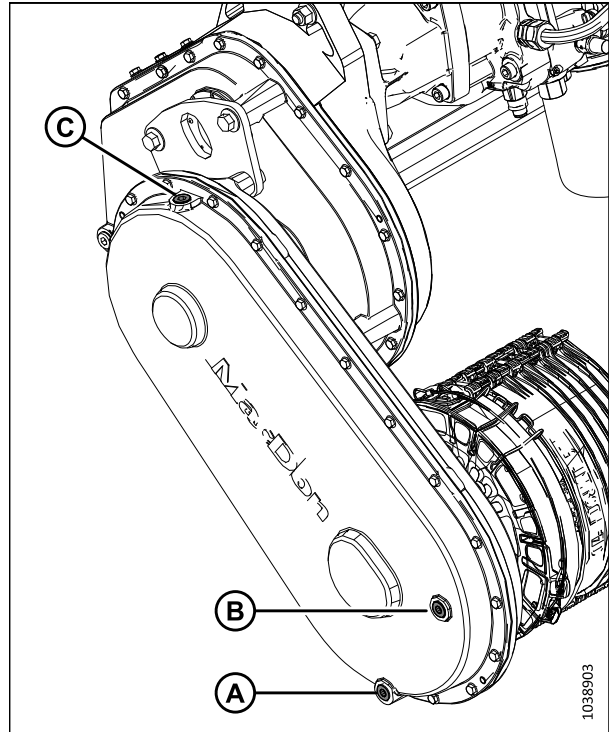


Figure 4.32: Header Drive Completion Gearbox



## 4.4 Hydraulics

The float module frame acts as an oil reservoir. Refer to the inside back cover for more information on the float module's oil requirements.

### 4.4.1 Checking Oil Level in Hydraulic Reservoir

You can inspect the oil level in the header's hydraulic oil reservoir via the sight glass on the float module.

#### DANGER

To prevent injury or death from the unexpected start-up of the machine, always stop the engine and remove the key from the ignition before leaving the operator's seat for any reason.

#### DANGER

Ensure that all bystanders have cleared the area.

#### NOTE:

Inspect the hydraulic oil level when the hydraulic oil is cold.

1. Lower the header to the ground.
2. Fully retract the center-link.
3. Shut down the engine, and remove the key from the ignition.
4. Ensure that the oil level is at the full line (A) at all times.

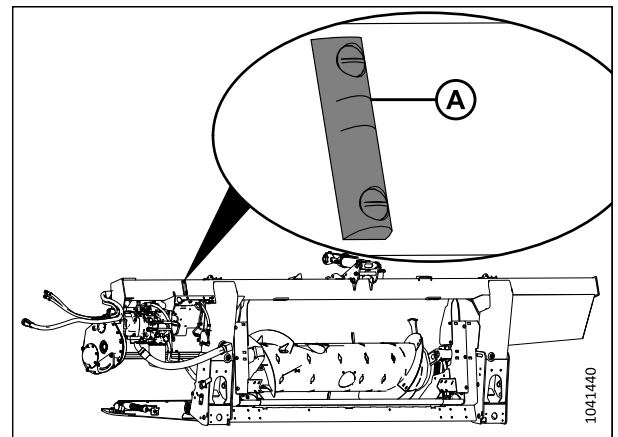


Figure 4.33: Oil Level Sight Gauge

### 4.4.2 Adding Oil to Hydraulic Reservoir

If the oil level in the hydraulic reservoir is low, or if the oil has been drained, you will need to add more oil.

#### DANGER

To prevent injury or death from the unexpected start-up of the machine, always stop the engine and remove the key from the ignition before leaving the operator's seat for any reason.

#### DANGER

Ensure that all bystanders have cleared the area.

1. Start the engine.
2. Engage the header to warm the oil.
3. Shut down the engine, and remove the key from the ignition.
4. Clean any dirt or debris from filler cap (A).

**CAUTION**

The oil reservoir may be under pressure; remove the cap slowly.

5. Turn filler cap (A) counterclockwise to remove it.
6. Fill the hydraulic oil reservoir with warm oil (approximately 21°C [70°F]) until the appropriate fill level is reached. Refer to [4.4.1 Checking Oil Level in Hydraulic Reservoir, page 595](#) for information on how to check the hydraulic oil level.

**IMPORTANT:**

Warm oil will flow through the mesh filler screen better than cold oil. Do **NOT** remove the screen.

**NOTE:**

The hydraulic oil tank capacity is approximately 95 L (25 gal).

7. Reinstall filler cap (A).
8. Recheck the oil level.

### 4.4.3 Changing Oil in Hydraulic Reservoir

Change the hydraulic oil in the reservoir every 1000 hours or 3 years (whichever comes first).

**DANGER**

To prevent injury or death from the unexpected start-up of the machine, always stop the engine and remove the key from the ignition before leaving the operator's seat for any reason.

**DANGER**

Ensure that all bystanders have cleared the area.

1. Start the engine.
2. Engage the header to warm up the oil.
3. Shut down the engine, and remove the key from the ignition.

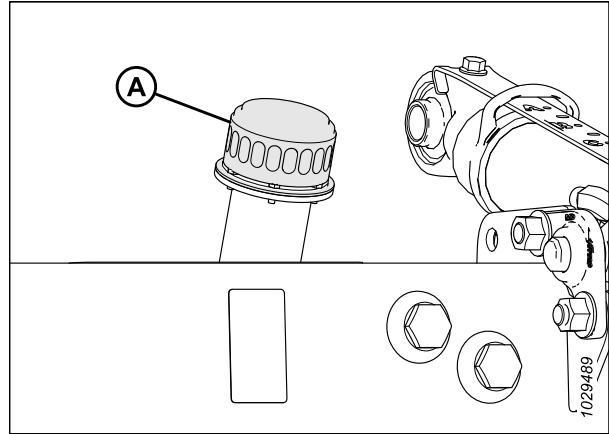


Figure 4.34: Oil Reservoir Filler Cap

## MAINTENANCE AND SERVICING

- Place a container with a capacity of at least 50 L (13 gal) under both oil drain plugs (A).
- Remove oil drain plugs (A) with a 7/8 in. hex socket. Allow the oil to drain completely.
- Reinstall oil drain plugs (A).
- If necessary, change the oil filter. For instructions, refer to [4.4.4 Changing Oil Filter, page 597](#).
- Add oil to the reservoir. For instructions, refer to [4.4.2 Adding Oil to Hydraulic Reservoir, page 595](#).

### NOTE:

The hydraulic oil tank capacity is approximately 95 L (25 gal).

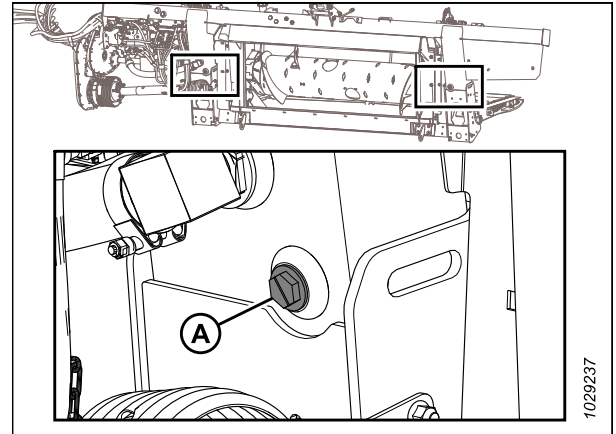


Figure 4.35: Reservoir Drain

### 4.4.4 Changing Oil Filter

The hydraulic oil filter removes solid contaminants that may interfere with the operation of the header's hydraulic system. The oil filter will need to be changed periodically.

Use filter kit (MD #320360) to replace the filter.

### DANGER

To prevent injury or death from the unexpected start-up of the machine, always stop the engine and remove the key from the ignition before leaving the operator's seat for any reason.

- Shut down the engine, and remove the key from the ignition.
- To change the oil filter on an FM200 IHS, do the following:
  - Clean around the mating surfaces of filter (A) and integrated pump (B).
  - Place a suitably sized container (approximately 1 liter [0.26 gallons]) under the filter to collect oil runoff.
  - Twist off filter (A) and clean the exposed filter port in the integrated pump.
  - Apply a thin film of clean oil to the O-ring provided with the new filter.
  - Fill filter (A) with oil before installing. For oil specifications refer to [Recommended Fluids and Lubricants, page](#) inside the back cover of the manual.
  - Turn the new filter onto integrated pump (B) until the O-ring contacts the mating surface. Tighten the filter an additional 1/2 to 3/4 turn by hand.

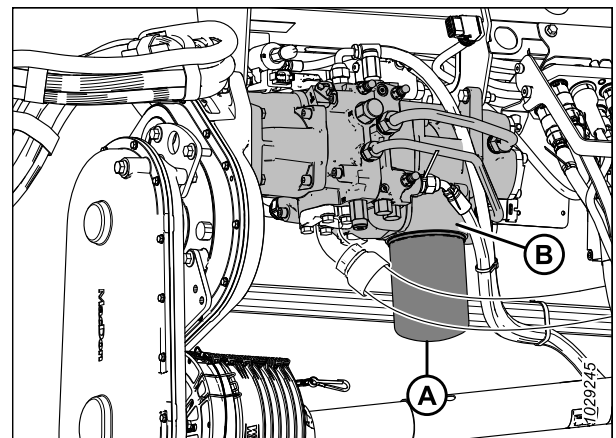


Figure 4.36: FM200 Integrated Hydraulic System (IHS)

### IMPORTANT:

Do **NOT** use a filter wrench to install the new filter. Overtightening can damage the O-ring and filter.

## MAINTENANCE AND SERVICING

3. To change the oil filter on an FM200 MHS, do the following:
  - a. Clean around the mating surfaces of filter (A) and modular manifold (B).
  - b. Place a suitably sized container (of a capacity of at least 1 liter [0.26 gallons]) under oil drain spout (C).
  - c. Remove the spin-off filter (A) and clean the exposed filter port on modular manifold (B).
  - d. Apply a thin film of clean oil to the O-ring provided with the new filter.
  - e. Place the new filter onto the threaded spindle on modular manifold (B). Tighten the filter until the O-ring contacts the mating surface. Tighten the filter an additional 1/2 to 3/4 turn by hand.

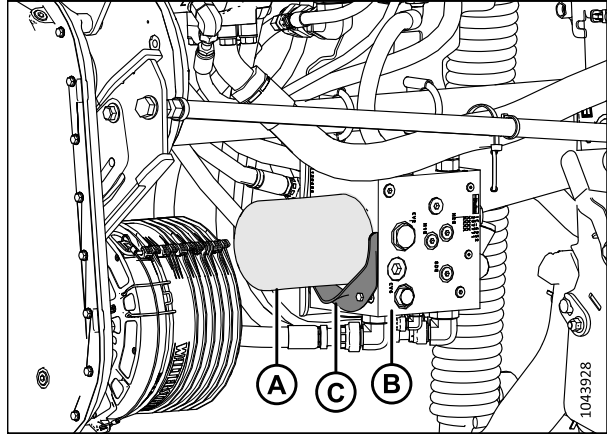


Figure 4.37: FM200 Modular Hydraulic System (MHS)

### IMPORTANT:

Do NOT use a filter wrench to install the new filter. Overtightening can damage the O-ring and the new filter.

## 4.5 Electrical System

The electrical system for the header is powered by the combine. The header has various lights and sensors that require power.

### 4.5.1 Replacing Light Bulbs

Lights are an important safety feature. Replace damaged or malfunctioning bulbs or lamps immediately.

#### DANGER

To prevent bodily injury or death from the unexpected start-up of the machine, always stop the engine and remove the key from the ignition before making adjustments to the machine.

Use bulb trade #1156 for amber transport lights and #1157 for the red tail light (transport option).

#### *Clearance lights (North America only)*

1. Shut down the engine, and remove the key from the ignition.
2. Use a Phillips screwdriver to remove three screws (A) from the fixture, and remove the plastic lens. Retain the screws.
3. Replace the bulb and reinstall the plastic lens and screws.

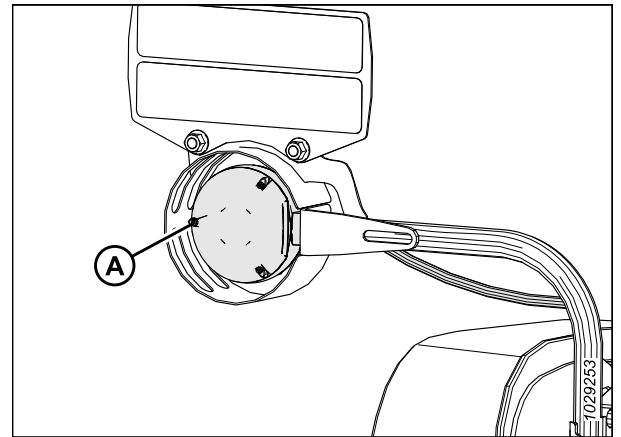


Figure 4.38: Left Clearance Light

#### *Transport lights*

4. Use a Phillips screwdriver to remove screws (A) from the fixture, and remove the plastic lens. Retain the screws.
5. Replace the bulb and reinstall the plastic lens and screws.

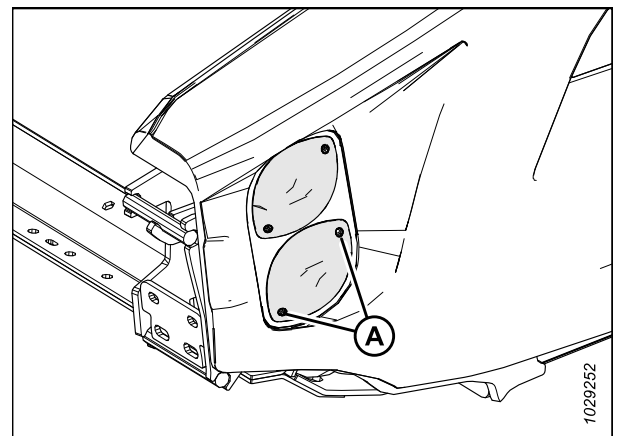


Figure 4.39: Transport Option – Red and Amber Lights

## 4.6 Header Drive

The header drive consists of a driveline from the combine to the FM200 Float Module gearbox that drives the feed auger and hydraulic pumps. The pumps provide hydraulic power to the drapers, knives, and optional equipment.

### 4.6.1 Removing Driveline

The driveline transfers power from the combine power take-off (PTO) to the header float module completion gearbox. A quick release collar allows the driveline to be removed when disconnecting the header float module from the combine.

#### DANGER

To prevent injury or death from the unexpected start-up of the machine, always stop the engine and remove the key from the ignition before leaving the operator's seat for any reason.

#### DANGER

Ensure that all bystanders have cleared the area.

1. Lower the reel fully.
2. Lower the header fully.
3. Shut down the engine, and remove the key from the ignition.
4. Disconnect driveline safety chain (A) from the slot on the aluminum plate.

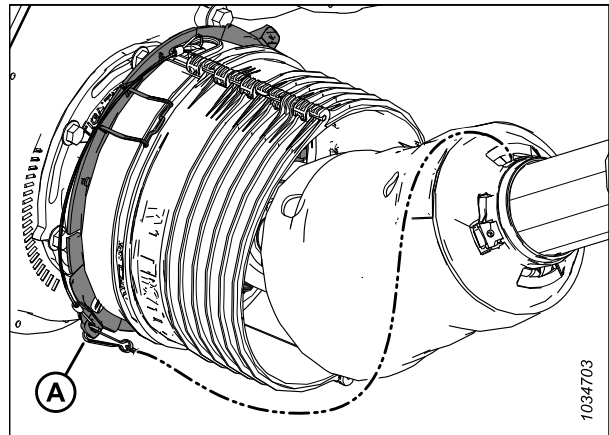


Figure 4.40: Driveline Shield

5. Pry clips (A) up to release shield (B).

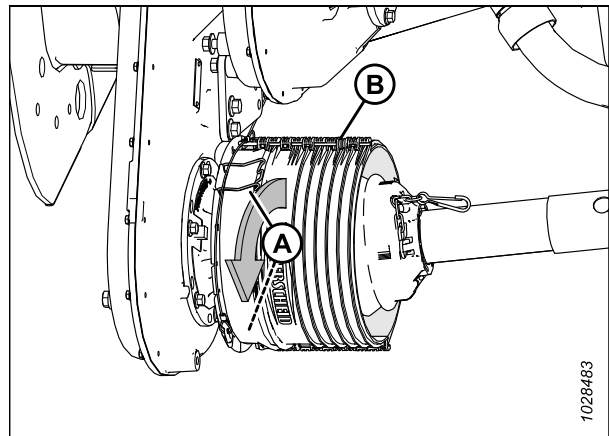


Figure 4.41: Driveline Shield

## MAINTENANCE AND SERVICING

- Slide shield (A) along the driveline to access quick disconnect collar (B).

**NOTE:**

If the shield does not slide, use a prying tool.

- Pull back quick disconnect collar (B) to release the driveline yoke. Slide the driveline off of the gearbox shaft.
- Slide the driveline through the shield, then lower it to the ground.

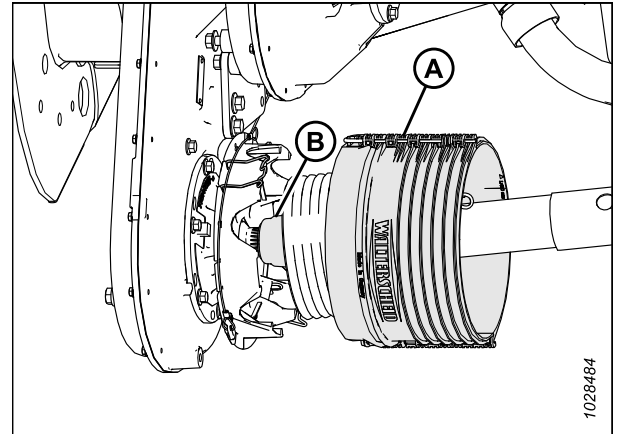


Figure 4.42: Driveline Shield

- Disconnect chain (D) from support bracket (B).
- On the opposite end of driveline (C), pull back quick disconnect collar (A) to release the driveline yoke.
- Slide the yoke off of support bracket (B).
- Remove driveline (C).

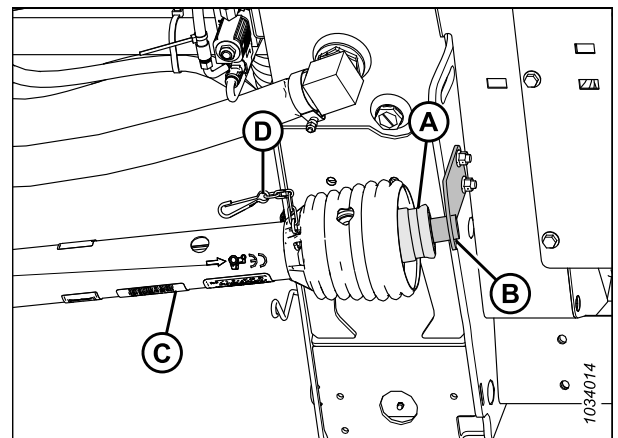


Figure 4.43: Driveline Shield

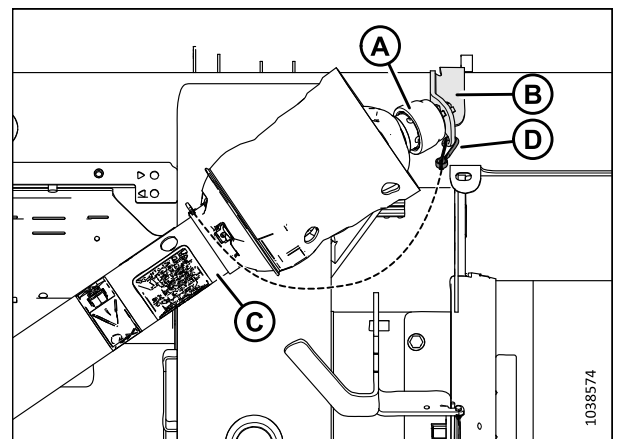


Figure 4.44: Optional Side-Hill Driveline Shield



## 4.6.2 Installing Driveline

The driveline transfers power from the combine power take-off (PTO) to the header's float module completion gearbox. It will need to be installed on the float module.

### DANGER

To prevent injury or death from the unexpected start-up of the machine, always stop the engine and remove the key from the ignition before leaving the operator's seat for any reason.

### DANGER

Ensure that all bystanders have cleared the area.

#### IMPORTANT:

If the driveline has been disassembled, ensure that the two halves are in phase before the driveline is installed on the header and combine. The image illustrates correct phasing (A) and incorrect phasing (B).

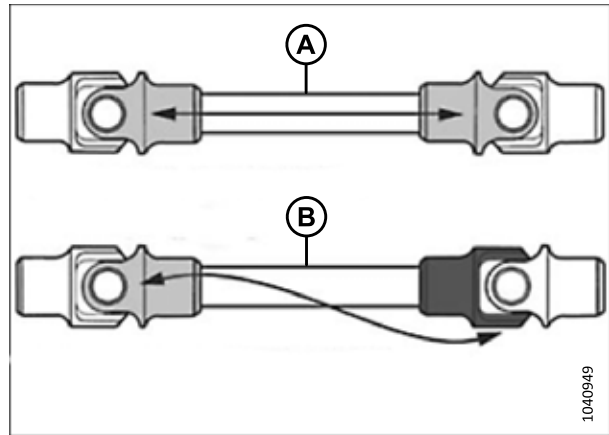


Figure 4.45: Determining Driveline Phase

1. Lower the reel fully.
2. Lower the header fully.
3. Shut down the engine, and remove the key from the ignition.
4. Position driveline support bracket (A) (supplied with the driveline) on the left inside of the float module as shown.
5. Secure the bracket with two M10 x 30 mm bolts and flange nuts (B).

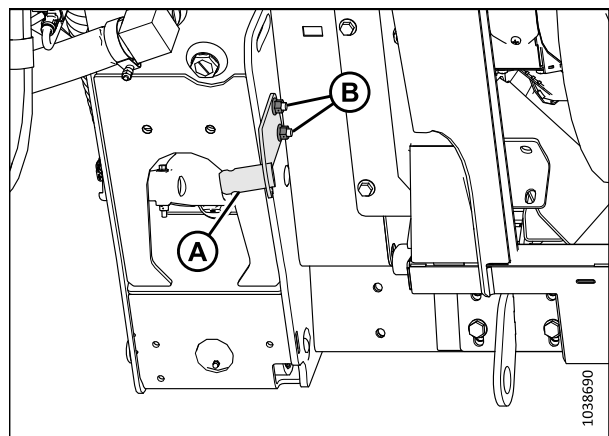


Figure 4.46: Driveline Support Bracket

## MAINTENANCE AND SERVICING

6. On the end of driveline (D) which has arrow (C) pointing toward the collar, pull back quick disconnect collar (A).
7. Slide the yoke onto support bracket (B).
8. Connect safety chain (E) to the support bracket.

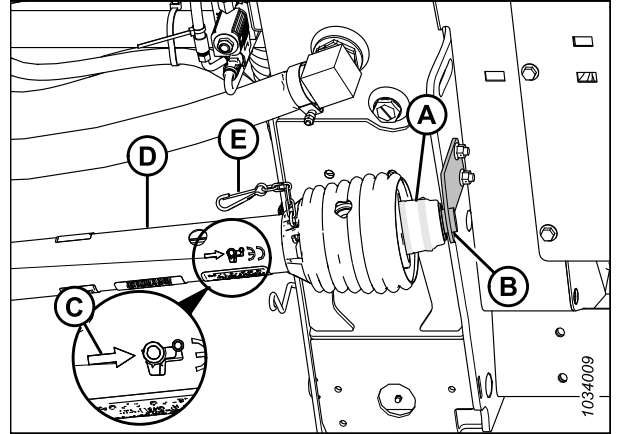


Figure 4.47: Driveline Shield

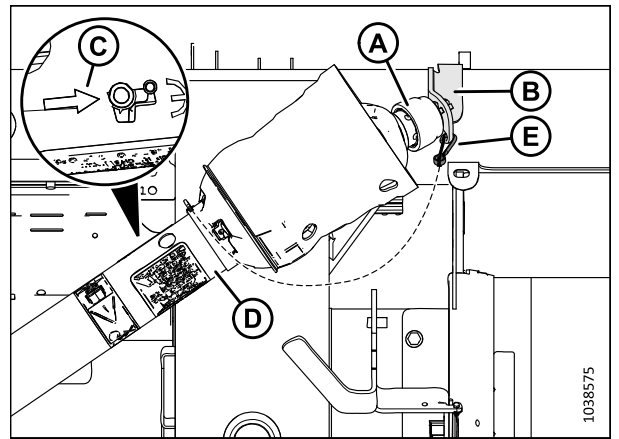


Figure 4.48: Optional Side-Hill Driveline Shield

9. Pry clips (A) up to release shield (B).

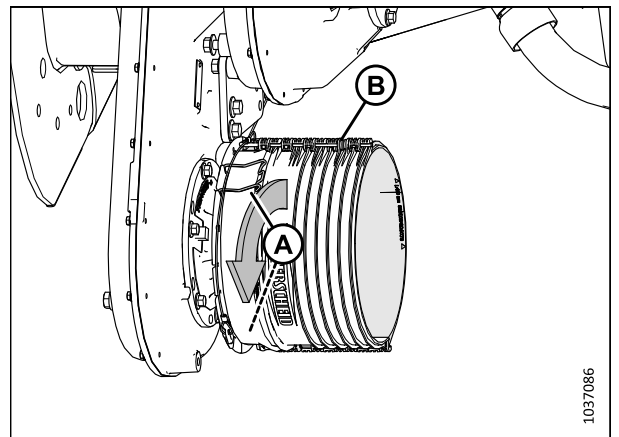


Figure 4.49: Driveline Shield

## MAINTENANCE AND SERVICING

- Slide the driveline through shield (A). Pull back quick disconnect collar (B) to release the driveline yoke.
- Slide the driveline onto the gearbox shaft until it locks onto the shaft.

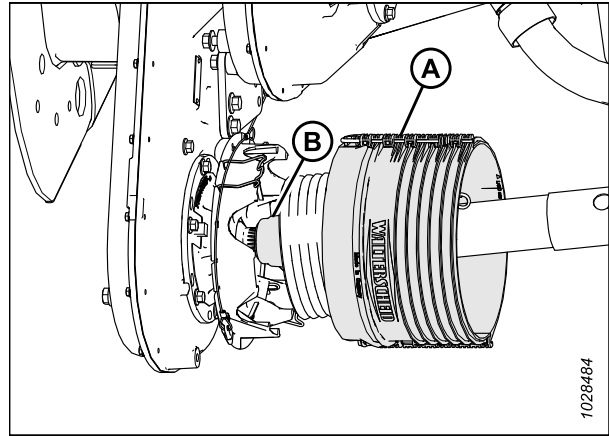


Figure 4.50: Driveline Shield

- Slide the shield toward the gearbox until clips (A) secure shield (B).

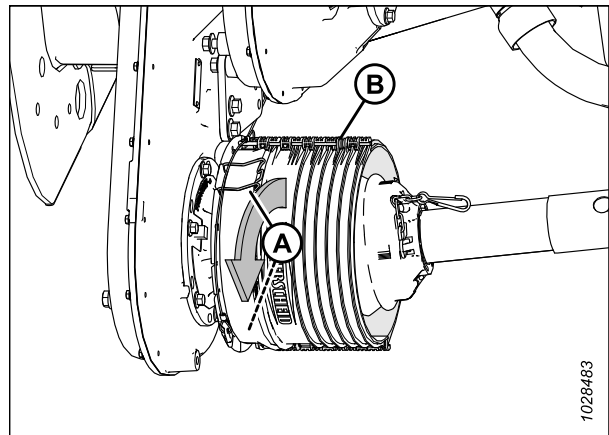


Figure 4.51: Driveline Shield

- Attach driveline safety chain (A) to the slot on the aluminum plate.

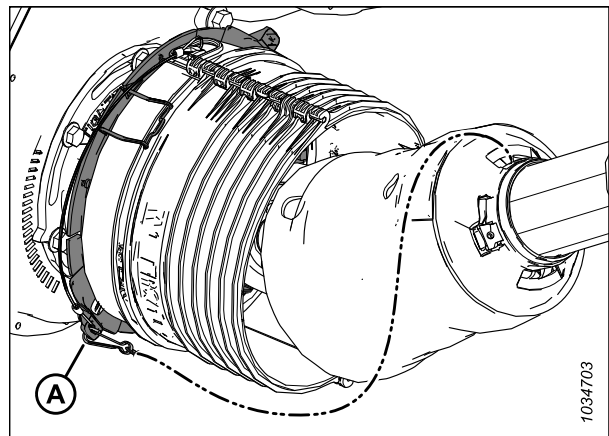


Figure 4.52: Driveline Shield

### 4.6.3 Removing Driveline Guard

The main driveline guard must remain attached to the driveline during operation, but you can remove it for maintenance purposes.

#### DANGER

To prevent injury or death from the unexpected start-up of the machine, always stop the engine and remove the key from the ignition before leaving the operator's seat for any reason.

#### NOTE:

The driveline does **NOT** need to be removed from the float module in order to remove the driveline guard.

1. Shut down the combine, and remove the key from the ignition.
2. Detach tether (D) and pull driveline collar (A) away from power take-off (PTO) support (B).
3. Slide yoke (C) off of support (B), and release collar (A).

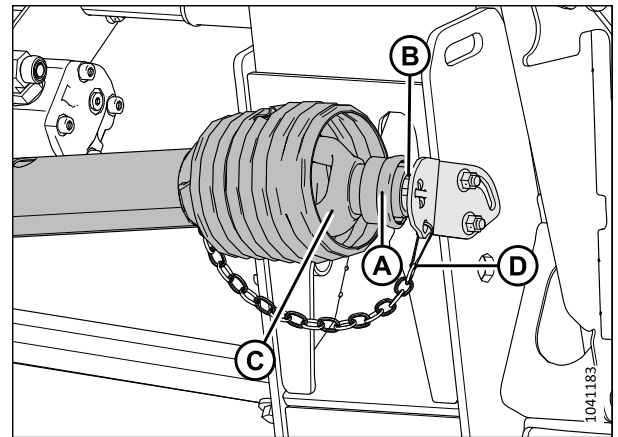


Figure 4.53: Combine End of Driveline

4. Lift the combine end of driveline (A) from the hook, and extend the driveline until it separates.

#### NOTE:

Hold the float module end of driveline (B) to prevent it from dropping and hitting the ground.



Figure 4.54: Separated Driveline

## MAINTENANCE AND SERVICING

5. Use a slotted screwdriver to release grease fitting/lock (A).



Figure 4.55: Driveline Guard

6. Rotate driveline guard locking ring (A) counterclockwise using a screwdriver until lugs (B) line up with the slots in the guard.
7. Pull the guard off the driveline.



Figure 4.56: Driveline Guard

#### 4.6.4 Installing Driveline Guard

Install the driveline guard before operating the header.

1. Slide the guard onto the driveline, and line up the slotted lug on locking ring (A) with arrow (B) on the guard.

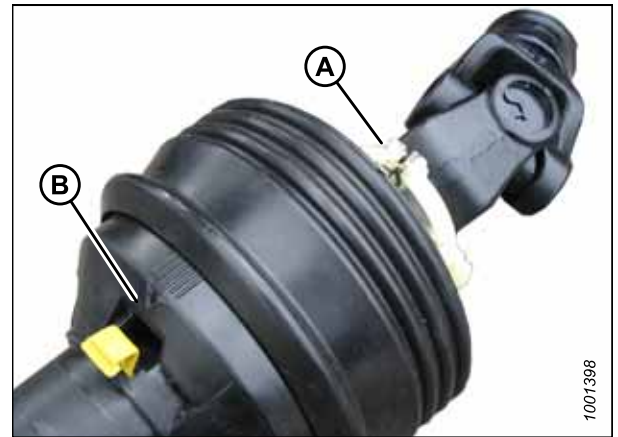


Figure 4.57: Driveline Guard

2. Push the guard onto the ring until the locking ring is visible in slots (A).



Figure 4.58: Driveline Guard

3. Use a slotted screwdriver to rotate ring (A) clockwise.



Figure 4.59: Driveline Guard

## MAINTENANCE AND SERVICING

4. Push grease fitting (A) back into the guard.



Figure 4.60: Driveline Guard

5. Assemble the driveline.

**IMPORTANT:**

The splines are keyed to align the universals. Align weld (A) with missing spline (B) when assembling. Failing to align the halves of the shaft can cause excessive vibration and feed auger/gearbox failures.

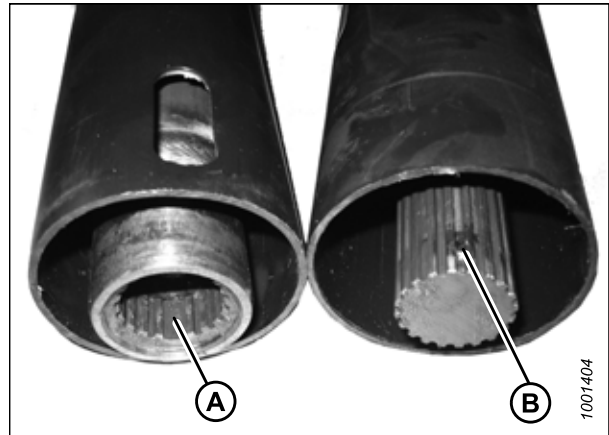


Figure 4.61: Driveline

6. Position the combine end of the driveline on power take-off (PTO) storage support (B).
7. Pull back collar (A) on the driveline and slide the driveline onto the support until driveline yoke (C) locks onto the support.
8. Release collar (A) and attach tether (D).

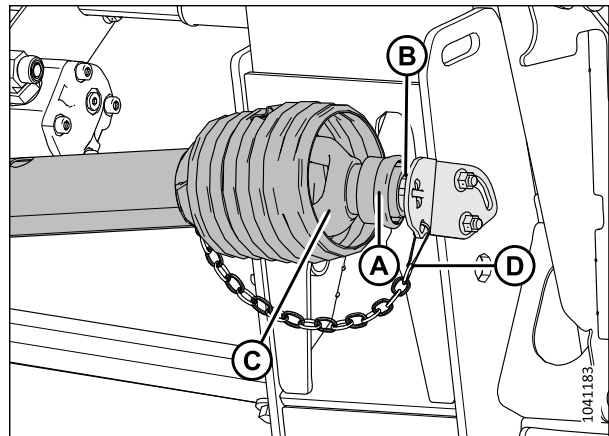


Figure 4.62: Combine End of Driveline



### 4.6.5 Adjusting Chain Tension – Main Gearbox

The tension of the gearbox drive chain is set at the factory, but adjustment is required after the first 50 hours, then every 500 hours or annually (whichever comes first). With the exception of oil changes, the gearbox drive chain requires no other regular maintenance.

**⚠ DANGER**

To prevent injury or death from the unexpected start-up of the machine, always stop the engine and remove the key from the ignition before leaving the operator's seat for any reason.

**⚠ DANGER**

Ensure that all bystanders have cleared the area.

1. Extend the hydraulic center-link fully.
2. Lower the header fully.
3. Shut down the engine, and remove the key from the ignition.
4. Remove four bolts (A), cover (B), and gasket (C) from the main gearbox. Retain the bolts.

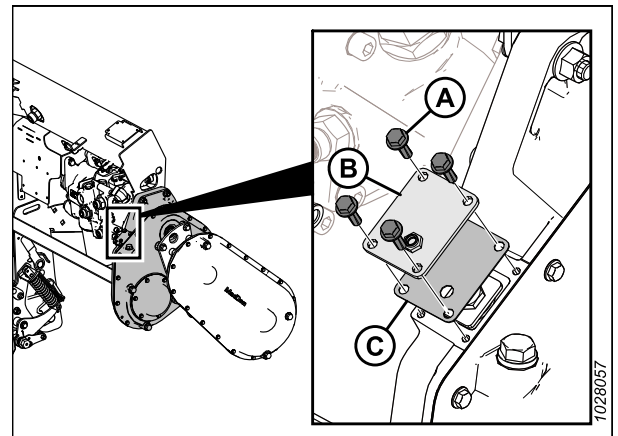


Figure 4.63: Main Gearbox Chain Tensioner Cover

5. Remove retainer plate (A).
6. Tighten bolt (B) to 2.5 Nm (1.8 lbf·ft [22 lbf·in]).
7. Loosen bolt (B) by 3 flats (1/2 turn).

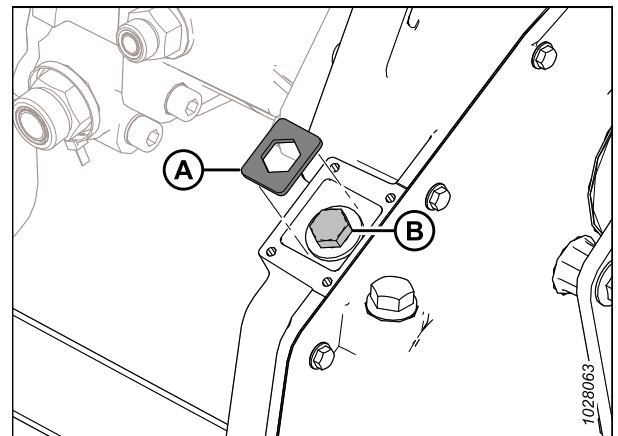


Figure 4.64: Main Gearbox Chain Tensioner

8. If necessary, turn bolt (B) slightly until retainer plate (A) can be installed.

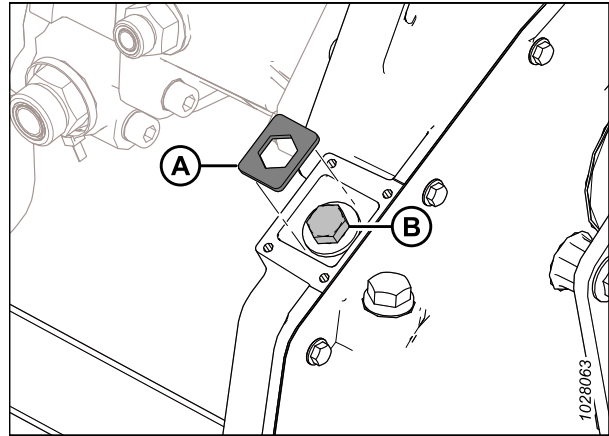


Figure 4.65: Main Gearbox Chain Tensioner

9. Reinstall chain adjusting cover (B) and gasket (C).
10. Install four bolts (A). Torque the bolts to 9.5 Nm (7 lbf·ft [84 lbf·in]).

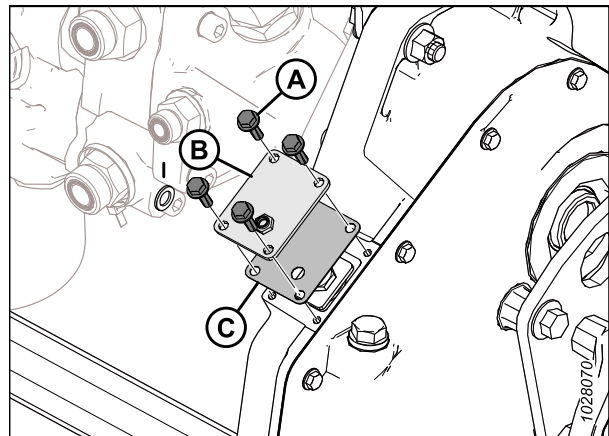


Figure 4.66: Main Gearbox Chain Tensioner Cover

#### 4.6.6 Adjusting Chain Tension – Completion Gearbox

The tension of the gearbox drive chain is set at the factory, but adjustment is required after the first 50 hours, then every 500 hours or annually (whichever interval comes first). With the exception of oil changes, the gearbox drive chain requires no other regular maintenance.

#### DANGER

To prevent injury or death from the unexpected start-up of the machine, always stop the engine and remove the key from the ignition before leaving the operator's seat for any reason.

#### DANGER

Ensure that all bystanders have cleared the area.

1. Lower the header fully.
2. Shut down the engine, and remove the key from the ignition.
3. Remove the driveline. For instructions, refer to [4.6.1 Removing Driveline, page 600](#).

## MAINTENANCE AND SERVICING

4. Remove three bolts (A) securing input driveline guard base (B).

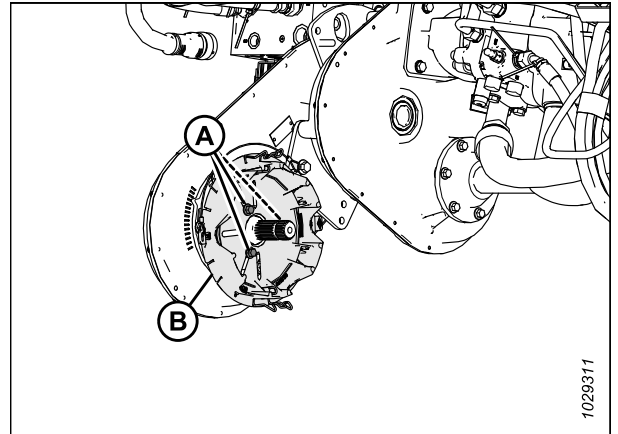


Figure 4.67: Completion Gearbox Chain Tensioner Cover

5. Loosen six bolts (B) securing chain tension hub (A) to the gearbox.
6. Locate machined feature (C). Using a wrench, turn hub (A) clockwise to tighten the chain.
7. With light pressure on the wrench, determine which mark (D) on the gearbox housing aligns with the indicator pointer on the hub.
8. Set the proper chain tension by slightly turning hub (A) back one mark.
9. On cover (A), tighten six bolts (B) to 25 Nm (18.4 lbf-ft [221 lbf-in]).

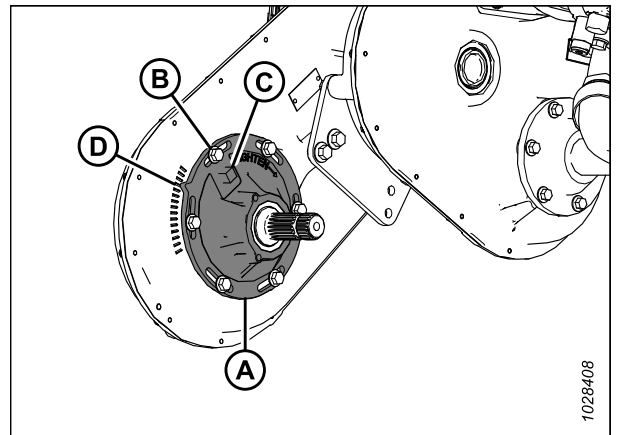


Figure 4.68: Completion Gearbox Chain Tensioner Cover

10. Install driveline guard base (B).
11. Secure the base with three bolts (A).
12. Install the driveline. For instructions, refer to [4.6.2 Installing Driveline](#), page 602.

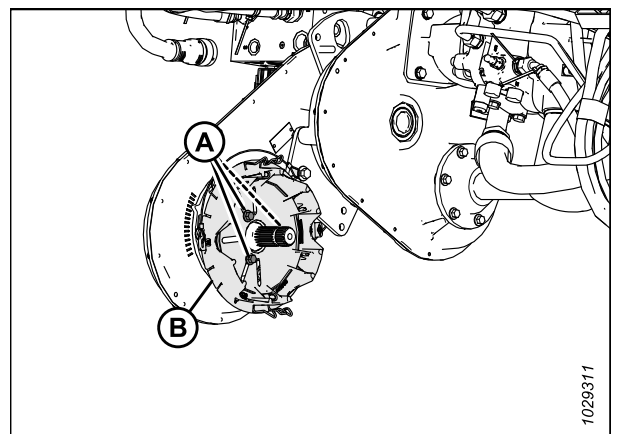


Figure 4.69: Completion Gearbox Chain Tensioner Cover

## 4.7 Feed Auger

The FM200 Float Module feed auger feeds the cut crop from the draper decks into the combine feeder house.

### 4.7.1 Adjusting Feed-Auger-to-Pan Clearance

There must be an adequate clearance between the feed auger and the pan on the float module to ensure that the crop feeds smoothly.

#### DANGER

To prevent injury or death from the unexpected start-up of the machine, always stop the engine and remove the key from the ignition before leaving the operator's seat for any reason.

#### DANGER

Ensure that all bystanders have cleared the area.

#### IMPORTANT:

Maintain an appropriate distance between the feed auger and the feed auger pan. Too little of a clearance may result in the fingers or the flighting contacting and damaging the feed draper or the pan when operating the header at certain angles. Look for any evidence of contact when greasing the float module.

1. Extend the center-link to the steepest header angle (setting E), and position the header 254–356 mm (10–14 in.) off the ground.
2. Shut down the engine, and remove the key from the ignition.
3. Lock the header wings. For instructions, refer to *Operating in Rigid Mode*, page 224.

#### CAUTION

To prevent cuts, pinches, and other bodily harm to the person checking the down stops, ensure that nobody is manually lifting, bouncing, or moving the header in any way while the down stop washer is being touched and checked for movement.

4. Ensure that the float lock linkage is on the down stops (washer [A] cannot move) at both locations.

#### NOTE:

If the header is **NOT** on the down stops, the voltage may go out of range during operation and cause the AHHC system to malfunction. To fix the problem, make the header heavier by decreasing the float. For instructions, refer to *Checking and Adjusting Header Float*, page 210.

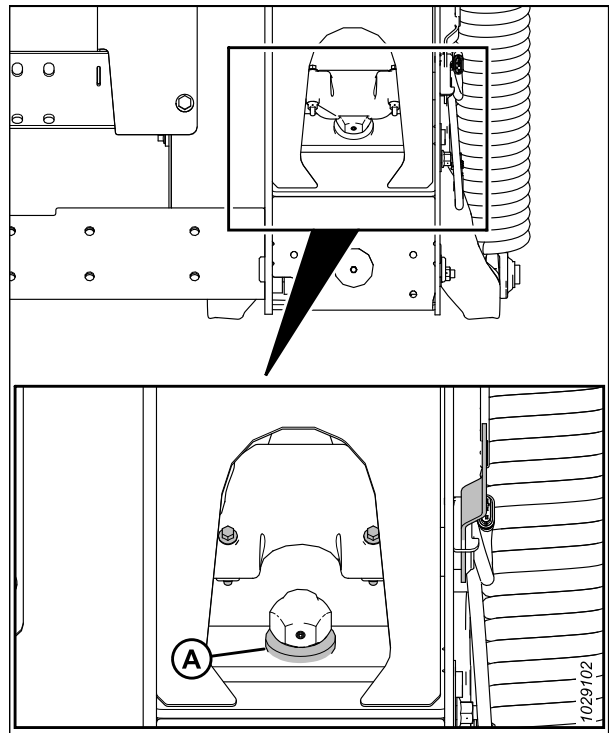


Figure 4.70: Down Stop Washer

## MAINTENANCE AND SERVICING

5. Before adjusting the auger-to-pan clearance, check the auger float position to determine how much of a clearance is required:

**IMPORTANT:**

Ensure that bolts (A) are set at the same location on both ends of the header to prevent damage to the machine during operation.

- If bolt head (A) is closest to floating symbol (B), the auger is in the floating position.

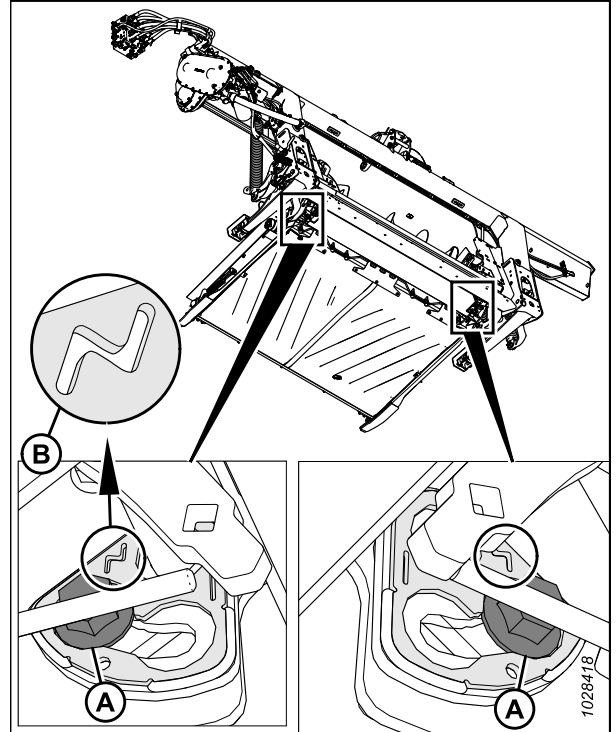


Figure 4.71: Floating Position

- If bolt head (A) is closest to fixed symbol (B), the auger is in the fixed position.

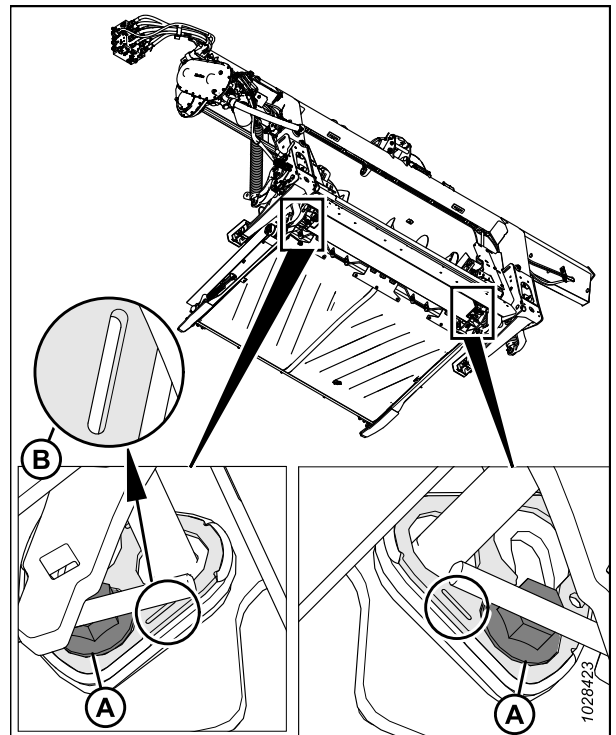


Figure 4.72: Fixed Position

## MAINTENANCE AND SERVICING

6. Check clearance (C) between the feed auger flighting and the pan.
  - If the feed auger is in the fixed position, the clearance should be 24–28 mm (15/16–1 1/8 in.).
  - If the feed auger is in the floating position, the clearance should be 11.5–15.5 mm (7/16–5/8 in.).
7. If the clearance requires adjustment, loosen two nuts (B) and rotate the auger to position the flighting over the feed pan.
8. Turn bolt (A) clockwise to increase clearance (C); turn bolt (A) counterclockwise to decrease clearance (C).
  - If the feed auger is in the fixed position, set the clearance to 24–28 mm (15/16–1 1/8 in.).
  - If the feed auger is in the floating position, set the clearance to 11.5–15.5 mm (7/16–5/8 in.).

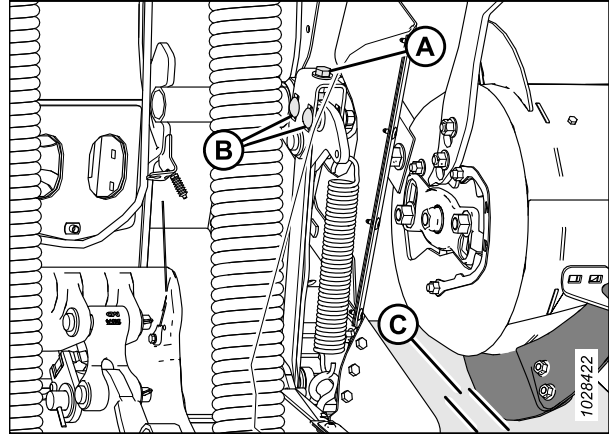


Figure 4.73: Auger Clearance

### NOTE:

The clearance increases between 25–40 mm (1–1 1/2 in.) when the center-link is fully retracted.

9. Repeat Step 6, page 614 to Step 8, page 614 on the opposite end of the auger.

### IMPORTANT:

Adjusting one side of the auger can affect the other side. Always double-check both sides of the auger after making final adjustments.

10. Tighten nuts (B) on both ends of the feed auger. Torque the nuts to 96 Nm (70 lbf-ft).
11. Rotate the feed auger and double-check the clearances.

## 4.7.2 Checking Feed Auger Chain Tension

The feed auger is chain-driven by the float module drive system sprocket attached to the side of the auger.

There are two methods for checking the feed auger drive chain tension: the quick method is intended for frequent checks; the thorough method is more accurate and should be used when replacing or reinstalling the chain.

Refer to the appropriate procedure for checking the feed auger chain tension:

- [Checking Feed Auger Drive Chain Tension – Quick Method, page 614](#)
- [Checking Feed Auger Drive Chain Tension – Thorough Method, page 616](#)

### Checking Feed Auger Drive Chain Tension – Quick Method

The auger is chain-driven by the float module drive system sprocket attached to the side of the auger.



## DANGER

To prevent injury or death from the unexpected start-up of the machine, always stop the engine and remove the key from the ignition before leaving the operator's seat for any reason.

**⚠ WARNING**

To prevent bodily injury from the fall of a raised reel, always engage the reel safety props before going under the raised reel for any reason.

**⚠ WARNING**

Ensure that all bystanders have cleared the area.

**NOTE:**

There are two methods for checking the auger drive chain tension: the quick method is intended for frequent checks; the thorough method (refer to [Checking Feed Auger Drive Chain Tension – Thorough Method, page 616](#)) is more accurate and should be used when the auger drive chain is reinstalled or replaced.

1. Lower the header fully.
2. Raise the reel fully.
3. Shut down the engine, and remove the key from the ignition.
4. Engage the reel safety props. For instructions, refer to [Engaging Reel Safety Props, page 39](#).
5. Rotate auger (A) by hand in the reverse direction until it cannot turn anymore.
6. Mark a line (B) across the drum and bottom cover.

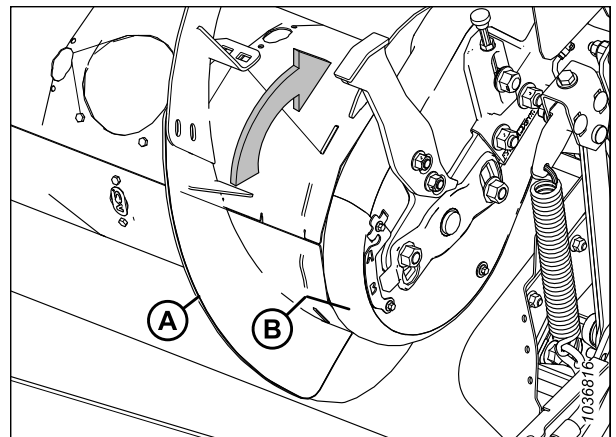


Figure 4.74: Feed Auger Drive

7. Rotate auger (A) by hand in the forward direction until it cannot turn anymore. The marked line will split.

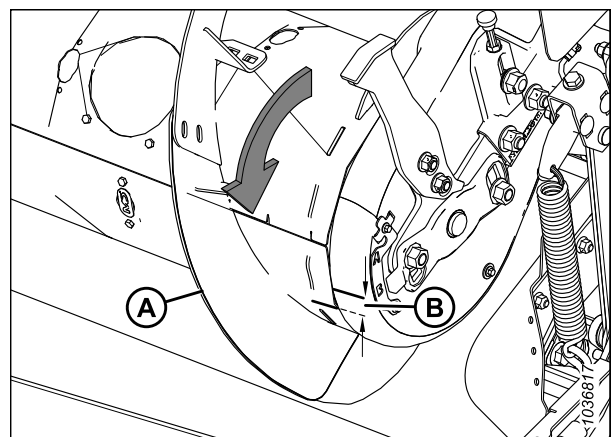


Figure 4.75: Feed Auger Drive



## MAINTENANCE AND SERVICING

8. Measure the distance between two lines (B).

For a new chain:

- If distance (B) is 1–4 mm (0.04–0.16 in.), no adjustment is required.
- If distance (B) is greater than 4 mm (0.16 in.), the auger drive chain tension needs adjusting. For instructions, refer to [4.7.3 Adjusting Feed Auger Drive Chain Tension, page 618](#).

For a used chain:

- If distance (B) is 3–8 mm (0.12–0.31 in.), no adjustment is required.
- If distance (B) is greater than 8 mm (0.31 in.), the auger drive chain tension needs adjusting. For instructions, refer to [4.7.3 Adjusting Feed Auger Drive Chain Tension, page 618](#).

### *Checking Feed Auger Drive Chain Tension – Thorough Method*

The auger is chain-driven by the float module drive system sprocket attached to the side of the auger.

#### **DANGER**

To prevent injury or death from the unexpected start-up of the machine, always stop the engine and remove the key from the ignition before leaving the operator's seat for any reason.

#### **WARNING**

To prevent bodily injury from the fall of a raised reel, always engage the reel safety props before going under the raised reel for any reason.

#### **WARNING**

Ensure that all bystanders have cleared the area.

#### **NOTE:**

There are two methods for checking the auger drive chain tension: the thorough method is more accurate and should be used when reinstalling or replacing the chain; the quick method (refer to [Checking Feed Auger Drive Chain Tension – Quick Method, page 614](#)) is intended for frequent checks.

1. Lower the header fully.
2. Raise the reel fully.
3. Engage the reel safety props. For instructions, refer to [Engaging Reel Safety Props, page 39](#).
4. Detach the header from the combine. For instructions, refer to [3.6 Header Attachment/Detachment, page 74](#).
5. Shut down the engine, and remove the key from the ignition.

## MAINTENANCE AND SERVICING

6. On the left side of the feed auger, remove four bolts (A) and inspection panel (B).
7. Remove bolts (C) and remove indicator/clamp (D) holding the two covers together.
8. Remove bolt (E).
9. Remove bolt and washer (H) securing bottom cover (F).
10. Rotate bottom cover (F) forward to remove it.

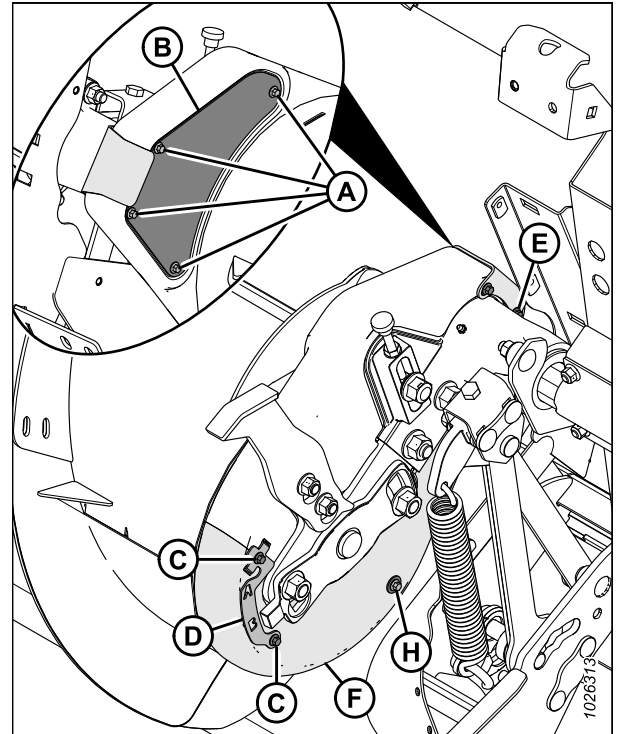


Figure 4.76: Feed Auger Drive – Rear View

11. Check the chain at midspan (A). There should be 4 mm (1/8 in.) of deflection. If adjustment is required, refer to [4.7.3 Adjusting Feed Auger Drive Chain Tension, page 618](#).

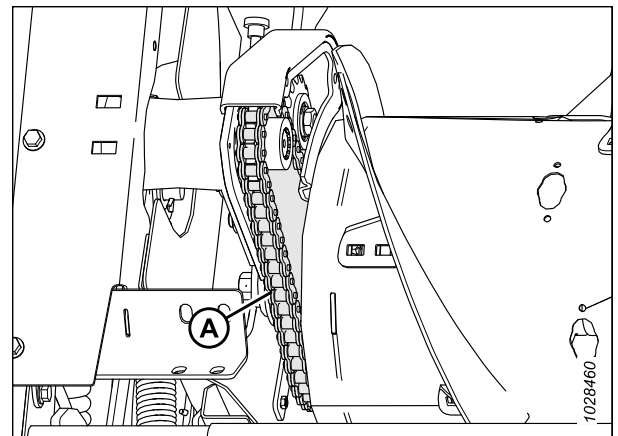


Figure 4.77: Feed Auger Chain – Rear View

12. Position bottom cover (F) and secure the cover with bolt and washer (H).
13. Install bolt (E).
14. Secure the bottom cover to the top cover with clamp/indicator (D) and bolts (C).
15. Install inspection panel (B) and secure it with four bolts (A). Tighten bolts (A) to 3.5 Nm (2.6 lbf·ft [30 lbf·in]).

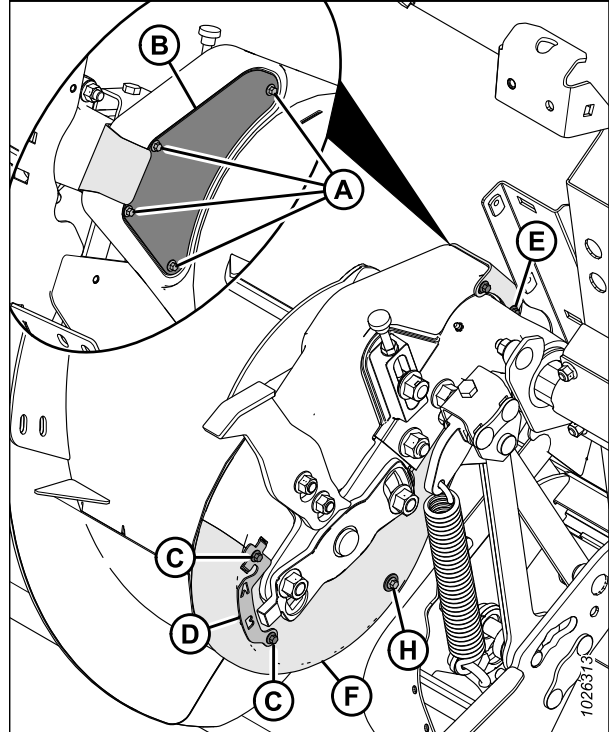


Figure 4.78: Feed Auger Drive – Rear View

### 4.7.3 Adjusting Feed Auger Drive Chain Tension

The auger is chain-driven by the float module drive system sprocket attached to the side of the auger. An insufficient tension on the chain can prematurely wear the sprockets or damage the chain.

#### DANGER

To prevent injury or death from the unexpected start-up of the machine, always stop the engine and remove the key from the ignition before leaving the operator's seat for any reason.

#### WARNING

To prevent bodily injury from the fall of a raised reel, always engage the reel safety props before going under the raised reel for any reason.

#### WARNING

Ensure that all bystanders have cleared the area.

1. Lower the header fully.
2. Raise the reel fully.
3. Engage the reel safety props. For instructions, refer to [Engaging Reel Safety Props, page 39](#).
4. Detach the header from the combine. For instructions, refer to [3.6 Header Attachment/Detachment, page 74](#).
5. Shut down the engine, and remove the key from the ignition.

## MAINTENANCE AND SERVICING

6. Remove four bolts (A) and inspection panel (B) to view the chain.

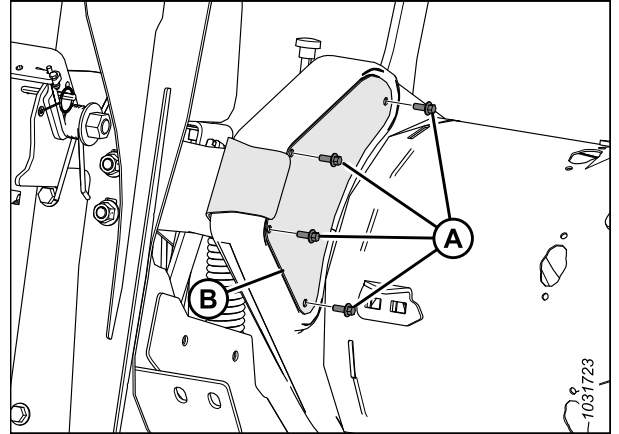


Figure 4.79: Left Side of Auger Drive – Rear View

7. Loosen jam nut (B).
8. Loosen idler nut (A) slightly to allow the idler to move by turning adjuster (C).
9. Rotate the auger in reverse to take up slack in the upper strand of the chain.

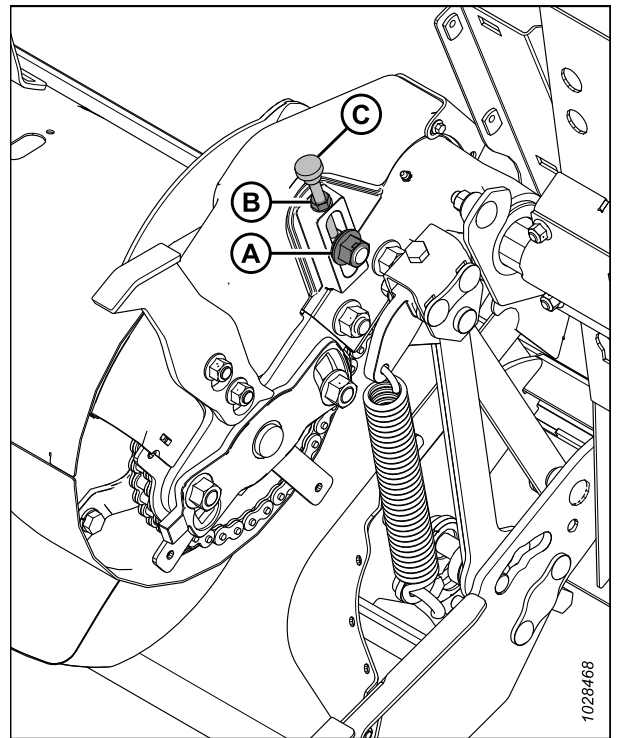


Figure 4.80: Left Side of Auger Drive – Front View

## MAINTENANCE AND SERVICING

- Turn adjuster thumbscrew (A) clockwise to increase the tension until chain deflection (B) is 4 mm (1/8 in.) at the midspan.

### IMPORTANT:

Do **NOT** overtighten the chain.

### NOTE:

The covers have been removed from the illustration for clarity.

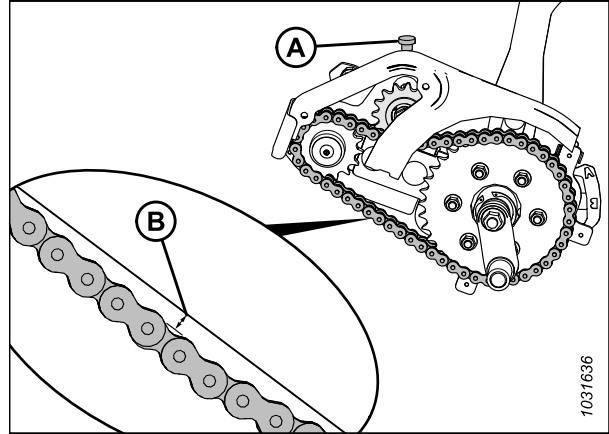


Figure 4.81: Feed Auger Chain Deflection

- After adjusting the tension, tighten jam nut (A).
- Tighten idler nut (B) and torque it to 265 Nm (195 lbf·ft).
- Recheck the midspan chain deflection after tightening the idler and jam nut.

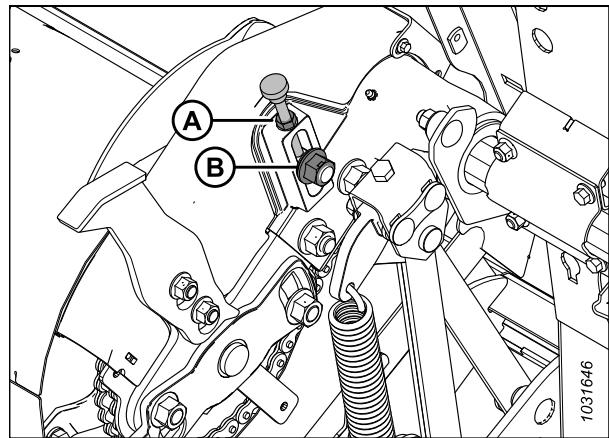


Figure 4.82: Feed Auger Chain – Front View

- Install inspection panel (B) and secure it with four bolts (A).
- Torque bolts (A) to 3.5 Nm (2.6 lbf·ft [30 lbf·in]).

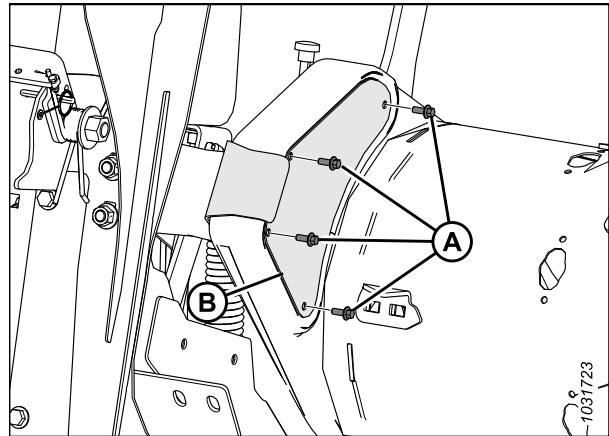


Figure 4.83: Left Side of Auger Drive – Rear View

### 4.7.4 Auger Flighting

The auger flighting on the FM200 can be configured for particular harvesting and crop conditions.

For instructions, refer to [3.8.1 FM200 Feed Auger Performance Configurations, page 158](#) for combine/crop specific configurations.

## 4.7.5 Auger Fingers

The FM200 feed auger uses retracting tines to feed the crop into the combine feeder house. Some conditions may require removing or installing the fingers for optimal crop feeding. Replace any worn or damaged fingers.

### *Removing Feed Auger Fingers*

The feed auger has fingers that extend and retract to pull crop into the feeder house on the combine. Remove fingers from the auger drum to change its configuration profile.

#### **DANGER**

To prevent bodily injury or death from the unexpected start-up of the machine, always stop the engine and remove the key from the ignition before making adjustments to the machine.

#### **WARNING**

Ensure that all bystanders have cleared the area.

#### **WARNING**

To prevent bodily injury from the fall of a raised reel, always engage the reel safety props before going under the raised reel for any reason.

#### **IMPORTANT:**

When removing auger fingers, work from the outside inward. Make sure there is an equal number of fingers on both sides of the auger when complete.

1. Raise the reel fully.
2. Shut down the engine, and remove the key from the ignition.
3. Engage the reel safety props. For instructions, refer to [Engaging Reel Safety Props, page 39](#).
4. Locate the access cover closest to the finger to be removed.
5. Remove and retain bolts (A) and access cover (B).

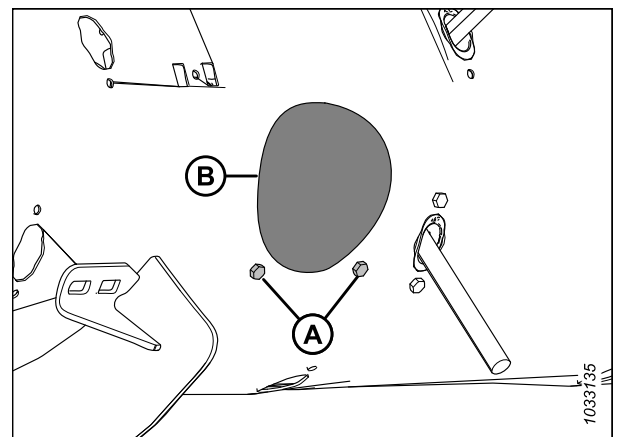


Figure 4.84: Auger Access Hole Cover

## MAINTENANCE AND SERVICING

6. Remove hairpin (A). Pull finger (B) out of finger holder (C).
7. If the finger is broken, remove any remnants from holder (C) and from inside the drum.

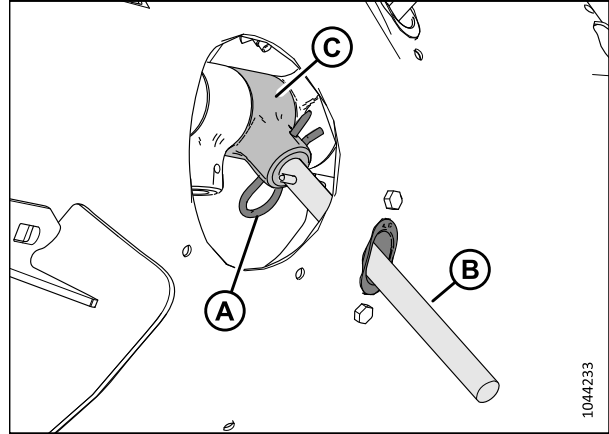


Figure 4.85: Auger Finger

8. Remove and retain two bolts (A) and the tee nuts (not shown) securing finger guide (B) to the auger.
9. Remove guide (B).

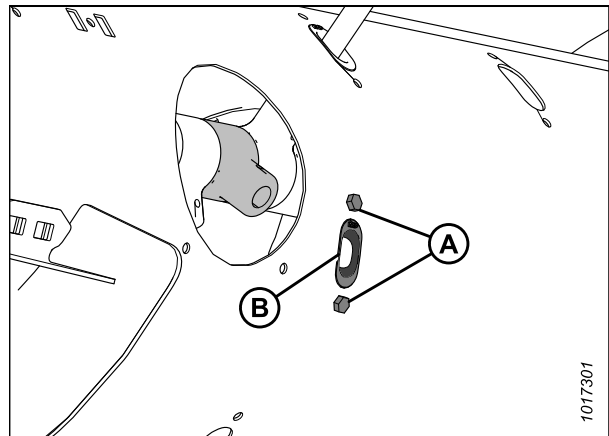


Figure 4.86: Auger Finger Hole

10. Place plug (A) in the hole from inside the auger.
11. Secure the plug with two M6 hex head bolts (B) and tee nuts. Torque the bolts to 9 Nm (6.63 lbf·ft [80 lbf·in]).

**NOTE:**

Bolts (B) come with a threadlocker patch that will wear off if the bolts are removed. If you are reinstalling bolts (B), apply medium-strength threadlocker (Loctite® 243 or equivalent) to the threads of the bolts before reinstallation.

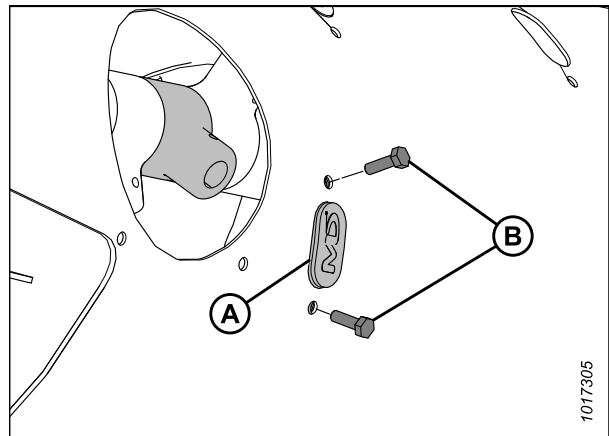


Figure 4.87: Plug Installed in Auger



## MAINTENANCE AND SERVICING

- Secure access cover (B) with bolts (A).
- Torque the bolts to 9 Nm (6.63 lbf-ft [80 lbf-in]).

### NOTE:

Bolts (A) come with a threadlocker patch that will wear off if the bolts are removed. If you are reinstalling bolts (A), apply medium-strength threadlocker (Loctite® 243 or equivalent) to the threads of the bolts before reinstallation.

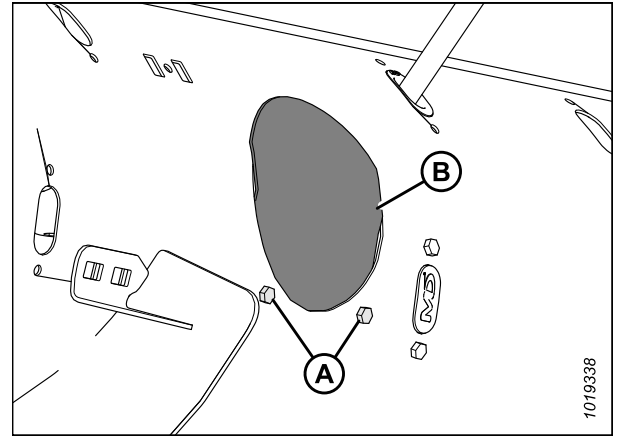


Figure 4.88: Auger Access Hole Cover

### Installing Feed Auger Fingers

The feed auger has fingers that extend and retract to pull crop into the feeder house on the combine. Install fingers onto the auger drum to change its configuration profile.

#### DANGER

To prevent bodily injury or death from the unexpected start-up of the machine, always stop the engine and remove the key from the ignition before making adjustments to the machine.

#### WARNING

Ensure that all bystanders have cleared the area.

#### WARNING

To prevent bodily injury from the fall of a raised reel, always engage the reel safety props before going under the raised reel for any reason.

### IMPORTANT:

When installing additional fingers, ensure that you install an equal number on each side of the auger.

- Start the engine.
- Raise the reel fully.
- Shut down the engine, and remove the key from the ignition.
- Engage the reel safety props. For instructions, refer to [Engaging Reel Safety Props, page 39](#).

## MAINTENANCE AND SERVICING

- Remove bolts (A) and access cover (B) closest to the finger you are removing. Retain the parts for reinstallation.

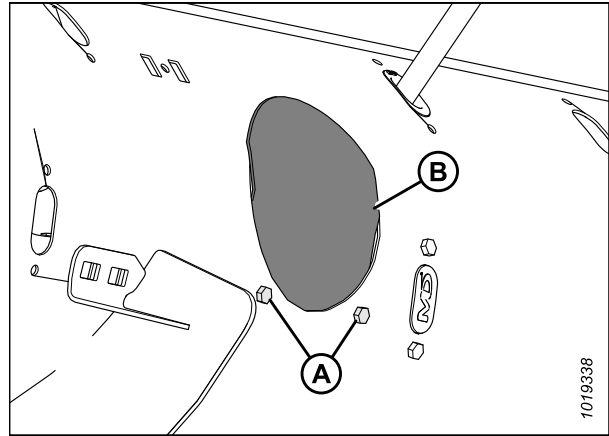


Figure 4.89: Auger Access Hole Cover

- Remove two bolts (B), tee nuts (not shown), and plug (A).

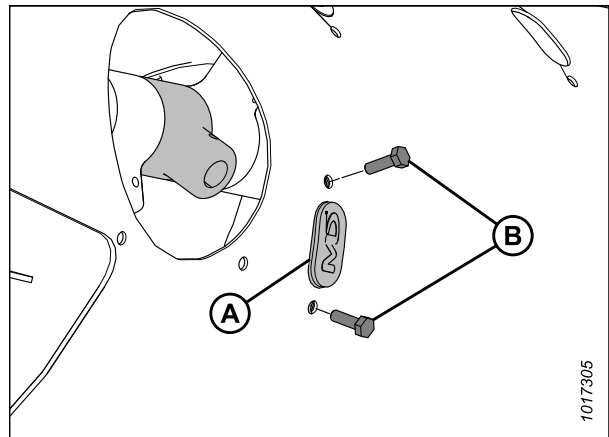


Figure 4.90: Auger Finger Hole

- Insert guide (B) from inside the auger and secure it with bolts (A) and tee nuts (not shown).

### IMPORTANT:

Always install a new guide when replacing a solid finger.

### NOTE:

Bolts (A) come with a threadlocker patch that will wear off if the bolts are removed. If you are reinstalling bolts (A), apply medium-strength threadlocker (Loctite® 243 or equivalent) to the threads of the bolts before reinstallation.

- Torque bolts (A) to 9 Nm (6.63 lbf·ft [80 lbf·in]).

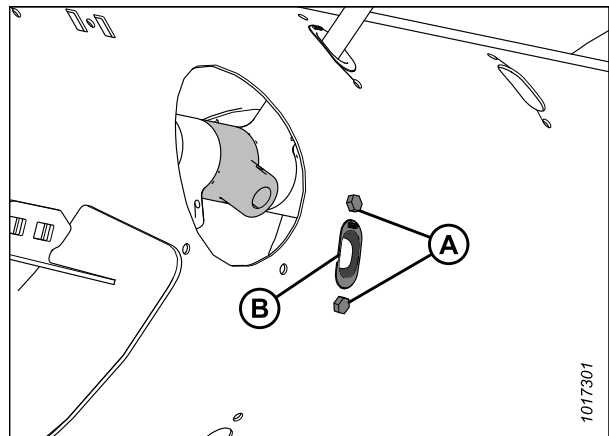


Figure 4.91: Auger Finger Hole

## MAINTENANCE AND SERVICING

- Place auger finger (A) from inside of the drum. Insert auger finger (A) up through the bottom of guide (B) and insert the other end into holder (C).
- Secure the finger by inserting hairpin (D) into the holder. Ensure that the round end (the S-shaped side) of the hairpin faces the chain drive side of the auger.

### IMPORTANT:

Position the hairpin as described in this step to prevent the hairpin from falling out during operation. If fingers are lost, the header might not be able to feed crop into the combine properly. Furthermore, fingers that fall into the drum might damage internal components.

### NOTE:

Make sure the closed end of the hairpin points in the direction in which the auger rotates.

- Secure access cover (B) in place with bolts (A). Torque the bolts to 9 Nm (6.63 lbf-ft [80 lbf-in]).

### NOTE:

Bolts (A) come with a threadlocker patch that will wear off if the bolts are removed. If you are reinstalling bolts (A), apply medium-strength threadlocker (Loctite® 243 or equivalent) to the threads of the bolts before reinstallation.

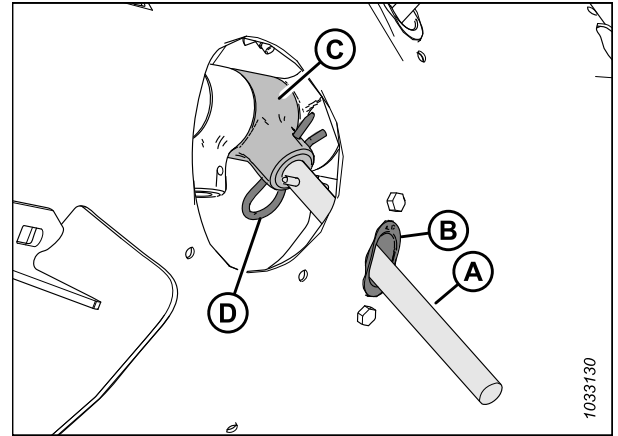


Figure 4.92: Auger Finger

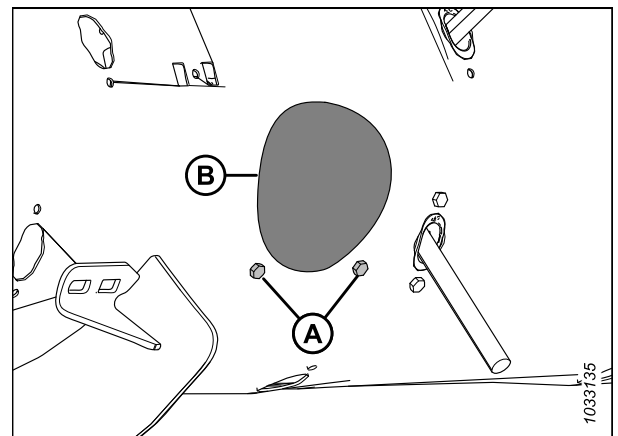


Figure 4.93: Auger Access Hole Cover

### Checking Auger Finger Timing

The feed auger has fingers that extend and retract to pull crop into the feeder house on the combine. This procedure determines where the fingers are when they are fully extended from the auger.

### DANGER

To prevent bodily injury or death from the unexpected start-up or fall of a raised machine, always stop the engine and remove the key before leaving the operator's seat, and always engage the safety props before going under the machine for any reason.

### WARNING

Ensure that all bystanders have cleared the area.

- Raise the reel fully.
- Engage the reel safety props. For instructions, refer to *Engaging Reel Safety Props*, page 39.
- Shut down the engine, and remove the key from the ignition.

## MAINTENANCE AND SERVICING

4. Check that indicator (C) is set to the same position at each end of the auger.

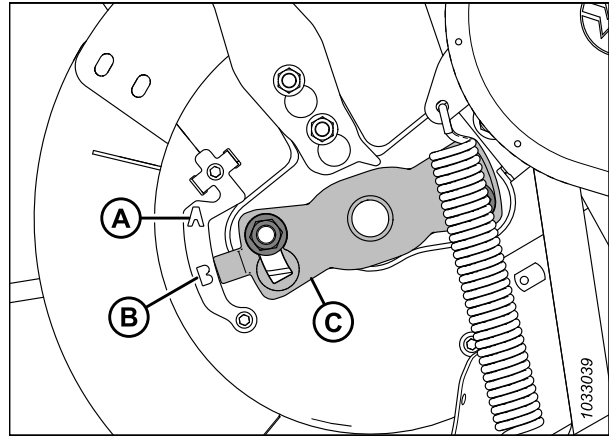
### NOTE:

There are two different auger tine extension positions: **A** and **B**. Position **A** is used for canola and position **B** is used for grains. The factory setting for the indicator is position **B**.

### IMPORTANT:

Both finger timing indicators **MUST** be set to the same position; if not, the auger will be damaged beyond repair.

5. To adjust the indicator position, refer to [Adjusting Auger Finger Timing, page 626](#).
6. Disengage the reel safety props. For instructions, refer to [Disengaging Reel Safety Props, page 40](#).



**Figure 4.94: Auger Tine Timing – Left Side of Auger Shown**

### Adjusting Auger Finger Timing

The feed auger fingers extend and retract to pull crop into the feeder house on the combine. This procedure determines where the fingers are when they are fully extended from the auger.

### NOTE:

The illustrations show only the left side of the auger; however, this procedure applies to both sides.

### DANGER

To prevent injury or death from the unexpected start-up of the machine, always stop the engine and remove the key from the ignition before leaving the operator's seat for any reason.

### WARNING

To prevent bodily injury from the fall of a raised reel, always engage the reel safety props before going under the raised reel for any reason.

### WARNING

Ensure that all bystanders have cleared the area.

1. Raise the reel fully.
2. Engage the reel safety props. For instructions, refer to [Engaging Reel Safety Props, page 39](#).
3. Shut down the engine, and remove the key from the ignition.

## MAINTENANCE AND SERVICING

4. Locate finger timing indicator (C) at the end of the auger. There are two auger tine extension positions: Position **A** and position **B**.
5. Loosen nuts (D) and adjust finger timing indicator (C) to the desired position.

### IMPORTANT:

Both finger timing indicators **MUST** be set to the same position; if not, the auger will be damaged beyond repair.

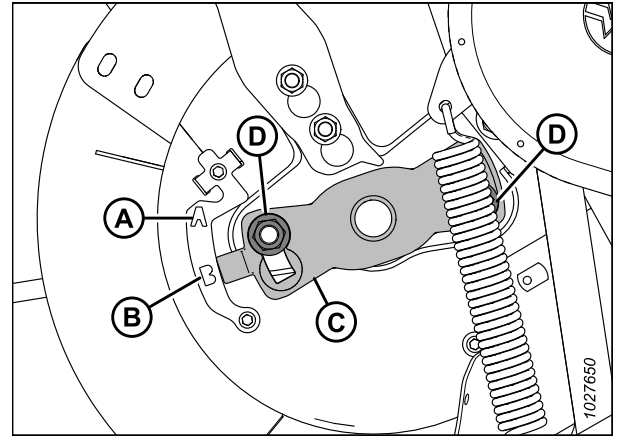


Figure 4.95: Auger Tine Timing Indicator

### NOTE:

If the finger timing indicator is pointing at position **A**, it indicates that the auger fingers will be fully extended at this point. This allows the crop to be engaged and released earlier before it enters the feeder house. This setting is best used for canola or bushy crops.

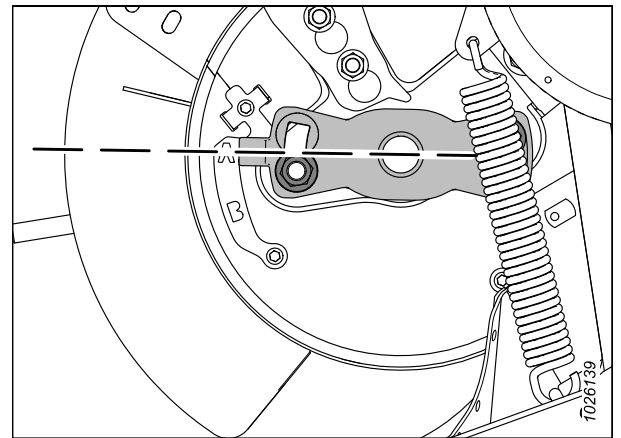


Figure 4.96: Auger Position A

### NOTE:

If the indicator is pointing at position **B**, it indicates that the auger fingers will be fully extended at that point. This allows the crop to be engaged and released later before it enters the feeder house. This setting is best used for grains or beans.

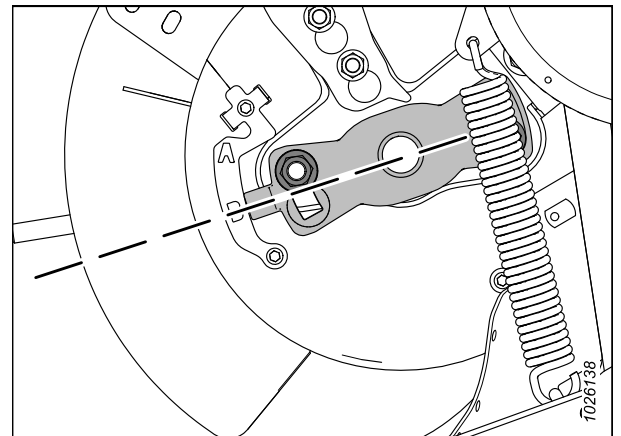


Figure 4.97: Auger Position B

## MAINTENANCE AND SERVICING

6. Once adjustment is complete, torque nuts (A) to 115 Nm (85 lbf-ft).
7. Disengage the reel safety props. For instructions, refer to [Disengaging Reel Safety Props, page 40](#).

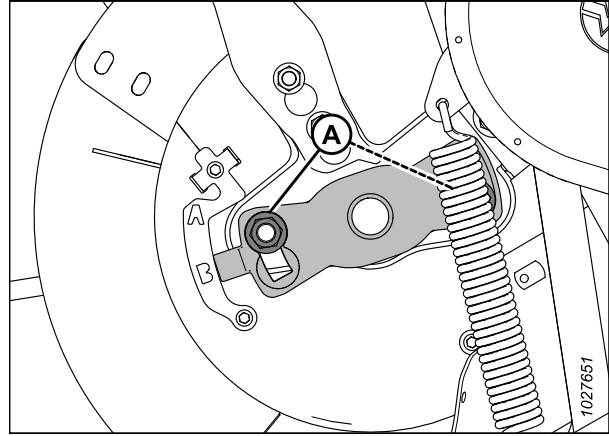


Figure 4.98: Auger Tine Timing Indicator

## 4.8 Knife

The knives on the cutterbar cut the crop. The knives, guards, and knifehead will require maintenance from time to time.

### WARNING

Keep hands clear of the area between the guards and the knife at all times.

### WARNING

Wear heavy gloves when working around or handling knives.

### CAUTION

Refer to [4.1 Preparing Machine for Servicing, page 567](#) before servicing the machine or opening the drive covers.

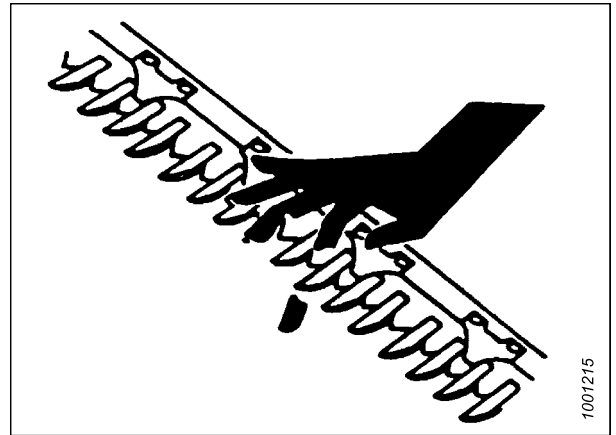


Figure 4.99: Cutterbar Hazard

### 4.8.1 Replacing Knife Section

Individual worn or damaged sections on a knife can be replaced without removing the knife from the cutterbar.

### DANGER

To prevent bodily injury or death from the unexpected start-up of the machine, always stop the engine and remove the key from the ignition before making adjustments to the machine.

### DANGER

Ensure that all bystanders have cleared the area.

### WARNING

To prevent bodily injury from the fall of a raised reel, always engage the reel safety props before going under the raised reel for any reason.

### WARNING

Wear heavy gloves when working around or handling knives.

1. Raise the reel fully.
2. Shut down the engine, and remove the key from the ignition.
3. Engage the reel safety props. For instructions, refer to [Engaging Reel Safety Props, page 39](#).



## MAINTENANCE AND SERVICING

- Identify the damaged knife section. If there is a hold-down, loosen nuts (A) securing hold-down (B) to access the damaged knife section.

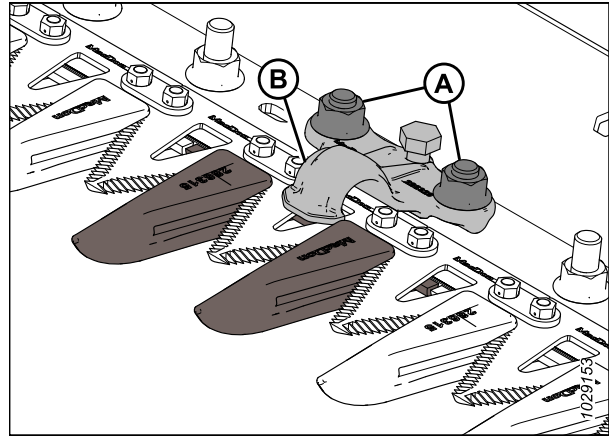


Figure 4.100: Cutterbar

- Remove bolts and nuts (B). Retain the hardware.

**NOTE:**

If the knife hardware is under a hold-down, rotate the knife flywheel to reposition the knife.

- For knife sections near the drive end, remove bars (C) and lift knife section (A) off of the knife back bar.
- Clean the knife back bar, and position the new knife section onto the back bar.

**NOTE:**

The cut quality may be affected if both fine and coarsely serrated knife sections are used on the same knife.

- For knife sections near the drive end, reposition bars (C).
- If a hold-down was removed earlier, reinstall it along with bolts and nuts (B).

**NOTE:**

Ensure that the bolt heads fully engage into the oblong holes on the knife back bar.

- Torque nuts (B) to 12 Nm (8.9 lbf-ft [106 lbf-in]).
- To check the hold-down adjustment, refer to *Checking Hold-Down – Pointed Knife Guards, page 645* or *Checking Hold-Down – Short Knife Guards, page 658*.

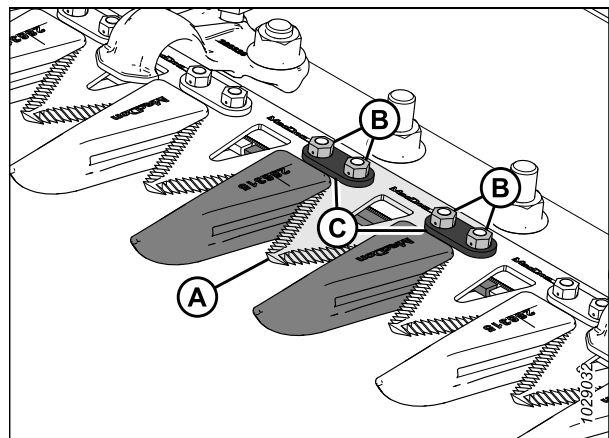


Figure 4.101: Cutterbar

### 4.8.2 Removing Knife

If the knife is damaged, it will need to be removed.

**⚠ DANGER**

To prevent bodily injury or death from the unexpected start-up of the machine, always stop the engine and remove the key from the ignition before making adjustments to the machine.

**⚠ WARNING**

Stand to the rear of the knife during removal to reduce the risk of injury from cutting edges. Wear heavy gloves when handling the knife.

**NOTE:**

On single-knife headers, the knifehead is located on the left side of the knife. On double-knife headers, there are two knifeheads located on the right and left sides of the knife. For double-knife headers, check which knife needs to be removed before starting the procedure.

1. Shut down the engine, and remove the key from the ignition.
2. Open the endshield. For instructions, refer to *Opening Header Endshields, page 41*.
3. Position the knife to the middle of its stroke range by rotating the flywheel attached to the knife drive box.
4. Clean the area around the knifehead.
5. Remove grease fitting (A) from the pin.

**NOTE:**

Removing the grease fitting will make it easier to reinstall the knifehead pin later.

6. Remove bolt and nut (B).
7. Use a screwdriver or a chisel in slot (C) to release the load on the knifehead pin.
8. Use a screwdriver or a chisel to pry the knifehead pin upward in the pin groove until the pin is clear of the knifehead.

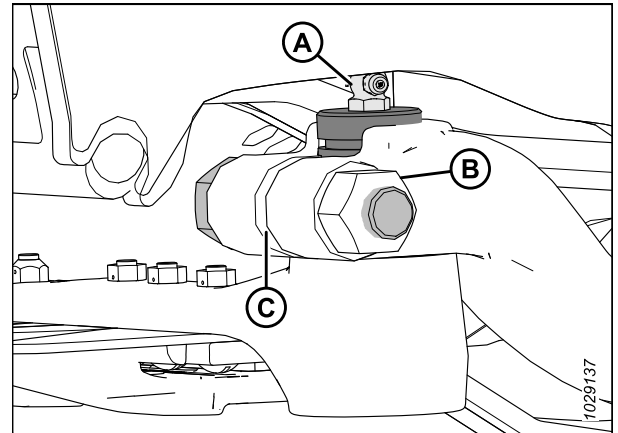


Figure 4.102: Knifehead

9. Push knife assembly (A) inboard until it is clear of drive arm (B).

**NOTE:**

The frame and the endshield parts have been removed from the illustration to reveal the knifehead components.

10. Unless it is being replaced, seal knifehead bearing (C) with plastic or tape to keep out dirt and debris.
11. Pull knife drive arm (B) to the outside position to give clearance for the knife.

**NOTE:**

If the knifehead or the knifehead bearing is being removed, pull the knife out far enough to access these parts.

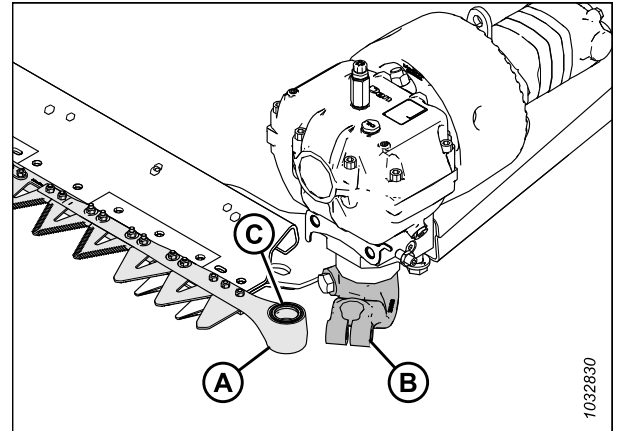


Figure 4.103: Left Knifehead

12. Remove knife (A).

### 4.8.3 Installing Knife

If the knife has been removed, follow this procedure to install it.

**! DANGER**

To prevent bodily injury or death from the unexpected start-up of the machine, always stop the engine and remove the key from the ignition before making adjustments to the machine.

**WARNING**

Stand to the rear of the knife during removal to reduce the risk of injury from cutting edges. Wear heavy gloves when handling the knife.

1. Shut down the engine, and remove the key from the ignition.
2. Open the endshield. For instructions, refer to *Opening Header Endshields, page 41*.

**NOTE:**

The installation illustrations show the left knife being installed. The procedure is the same for installing the right knife.

3. Lubricate knifehead bearing (A), then install the knife assembly onto the header.

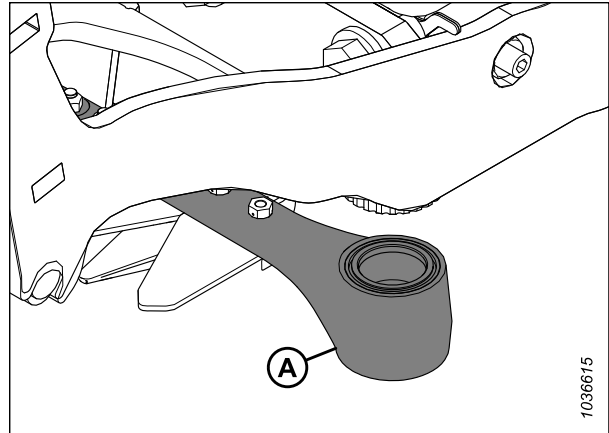


Figure 4.104: Knifehead

4. Install knifehead pin (A) through the drive arm and into the knifehead.
5. Position knifehead pin (A) so that groove (B) is 2 mm (0.08 in.) above the drive arm.

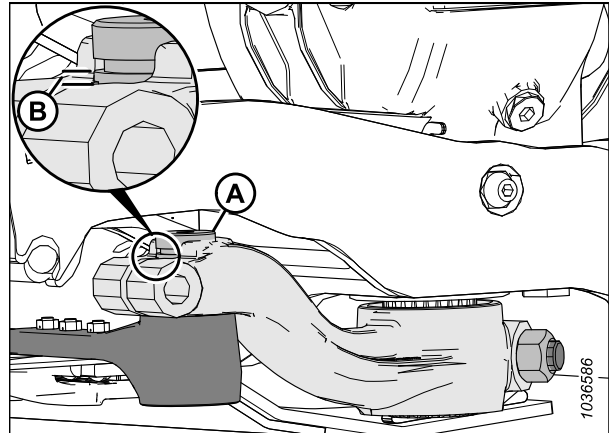


Figure 4.105: Knifehead

## MAINTENANCE AND SERVICING

- Secure the knifehead pin with M16 x 85 mm bolt (A) and nut (B). Install the bolt from the inboard side of the arm. Torque the bolt to 220 Nm (162 lbf·ft).
- Rotate the flywheel attached to the knife drive box to position knife arm (A) to the inside limit of travel. Ensure that there is still 0.2–1.2 mm (0.02–0.05 in.) of clearance (C) between the drive arm and the knifehead.
- If the drive arm does not need adjustment, proceed to Step 9, [page 633](#). If adjustment is needed, contact your Dealer.

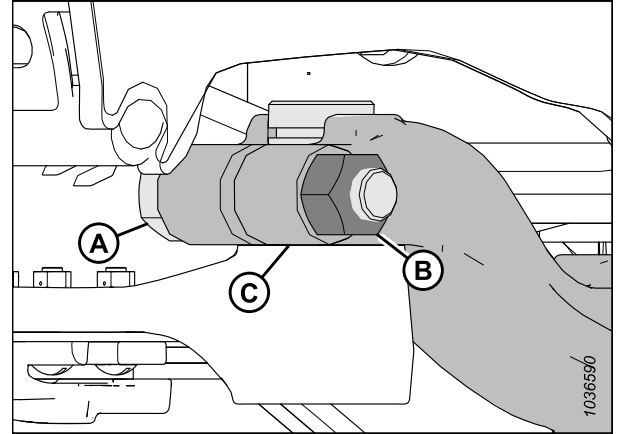


Figure 4.106: Knifehead

- Reinstall grease fitting (A). Apply grease to the fitting until the knifehead has a slight downward movement.

### IMPORTANT:

Do **NOT** overgrease the knifehead. Overgreasing the knifehead can misalign the knives, causing the guards to overheat and strain the knife drive motor. If you have applied too much grease to the fitting, remove the grease fitting to release the pressure.

### NOTE:

If air is trapped in the bearing cavity, the knifehead will begin to move down before it has filled with grease.

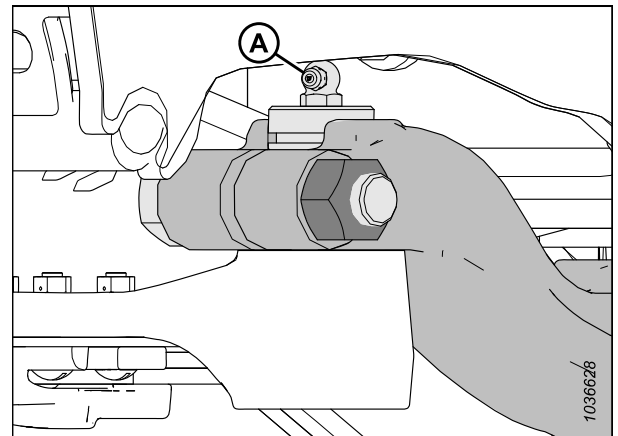


Figure 4.107: Knifehead

- Close the endshield. For instructions, refer to [Closing Header Endshields, page 42](#).

### 4.8.4 Spare Knives

Two spare knives (A) can be stored in the header backtube at the right end of the header. Ensure that the spare knives are secured in place with latch (B) and hairpin (C).

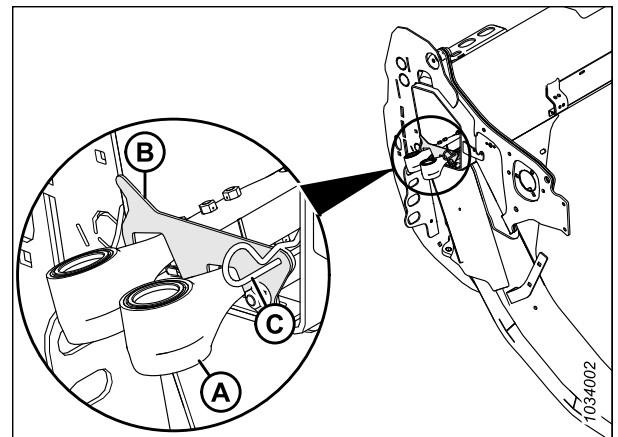


Figure 4.108: Spare Knives

### 4.8.5 Pointed Knife Guards and Hold-Downs

Knife guards help align the knife bar. Hold-downs hold the sections on the knife bar down against the knife guards to ensure proper cutting.

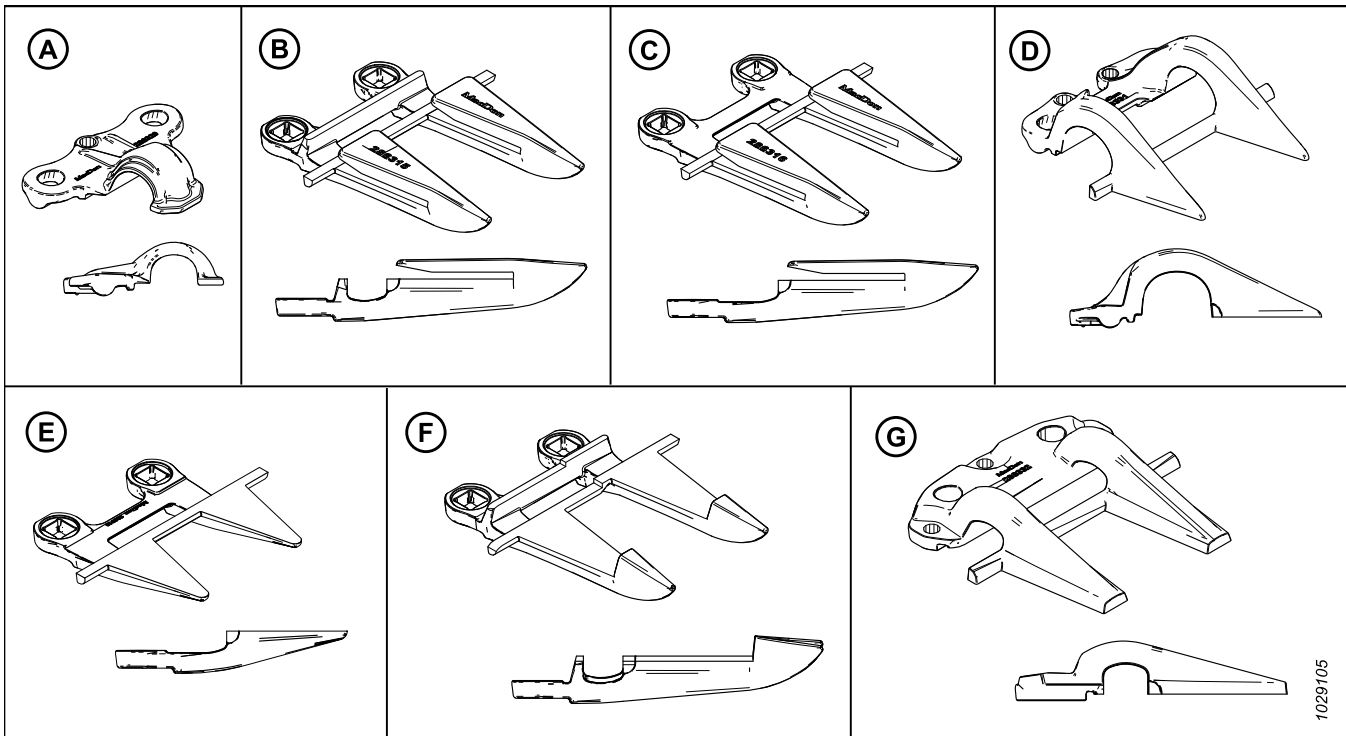
The following knife guards and hold-downs are used in pointed guard configurations:

**NOTE:**

Pointed knife guard configurations require two short knife guards, one at each end of the cutterbar.

**NOTE:**

A Four-Point Guard kit can be used to replace the knife guards. Four point guards are ideal for use in rocky conditions or for harvesting shatter-prone crops such as lentils. For more information, refer to the header parts catalog.



**Figure 4.109: Guard and Hold-Down Types Used in Pointed Knife Guard Configurations**

A - Pointed Hold-Down (MD #286329)

C - Pointed-End Knife Guard (without Wear Bar) (MD #286316)<sup>87</sup>

E - PlugFree™ End Knife Guard (without Wear Bar) (MD #286319)<sup>88</sup>

G - Pointed Center Hold-Down (MD #286332)<sup>89</sup>

B - Pointed Knife Guard (MD #286315)

D - PlugFree™ End Hold-Down (MD #286331)

F - Pointed Center Knife Guard (MD #286317)<sup>89</sup>

The guards are configured differently on different headers. When replacing pointed guards and hold-downs, ensure that you follow the correct replacement sequence for your header. Refer to the relevant topic:

- [Pointed Knife Guard Configuration on Single-Knife Headers, page 635](#)
- [Pointed Knife Guard Configuration on Double-Knife Header – FD235, page 636](#)
- [Pointed Knife Guard Configuration on Double-Knife Header – FD240, page 637](#)
- [Pointed Knife Guard Configuration on Double-Knife Header – FD241, page 638](#)

87. Installed in positions 2, 3, and 4 on the drive side(s). Refer to [Replacing Pointed Knife Guards, page 643](#).

88. Installed in position 1 on the drive side(s). Single-knife headers use a standard guard on the right end.

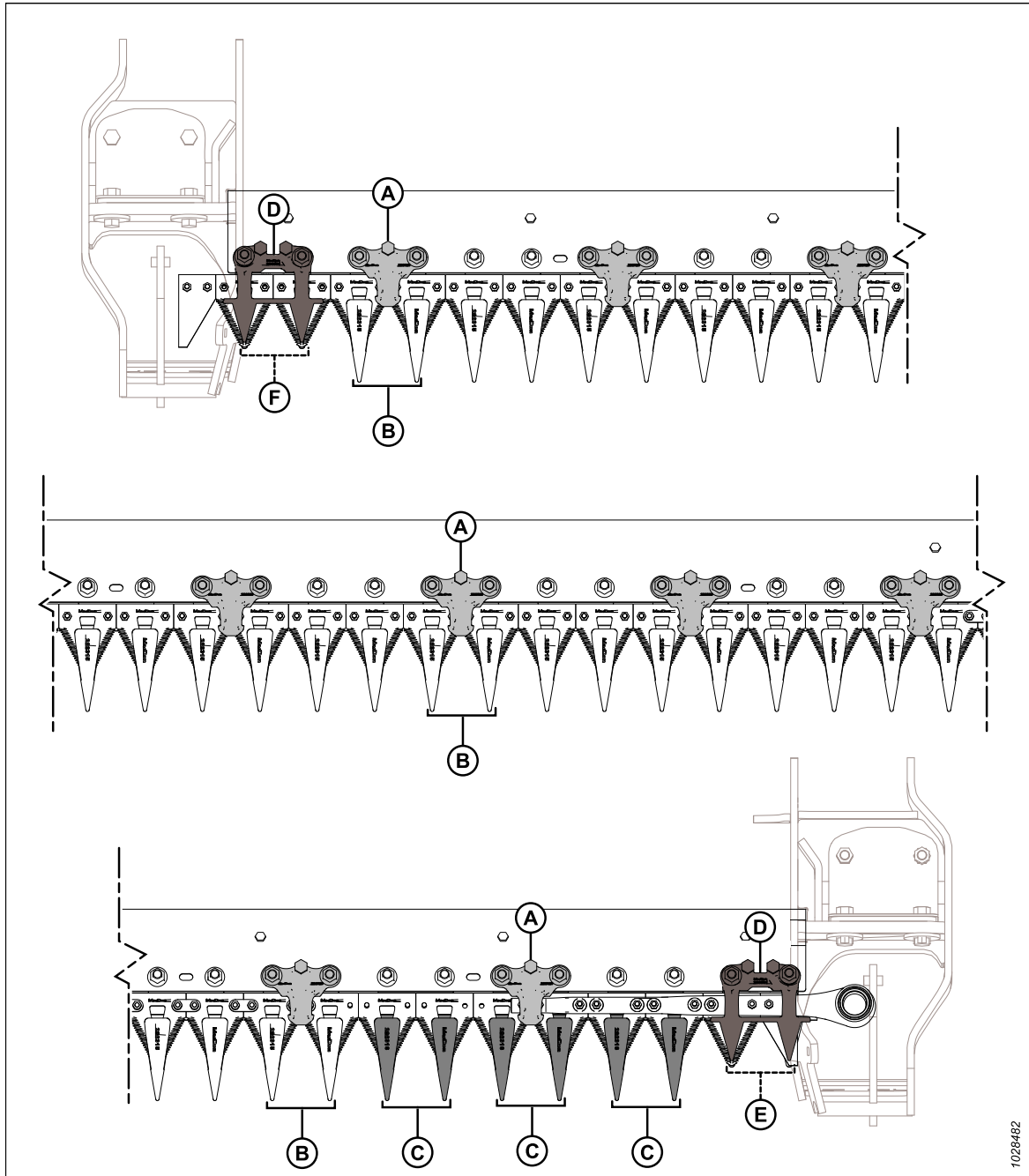
89. Double-knife headers only.

## MAINTENANCE AND SERVICING

- *Pointed Knife Guard Configuration on Double-Knife Header – FD245, page 639*
- *Pointed Knife Guards Configuration on Double-Knife Header – FD250, page 640*

### Pointed Knife Guard Configuration on Single-Knife Headers

Guards are configured differently on different sized headers. The illustration provided here shows pointed knife guards installed on single-knife headers.



**Figure 4.110: Pointed Knife Guard and Hold-Down Locations – Single-Knife Headers**

A - Pointed Hold-Down (MD #286329)

C - Pointed End Knife Guard (without Wear Bar) (MD #286316)

E - PlugFree™ Guard (without Wear Bar) (MD #286319)

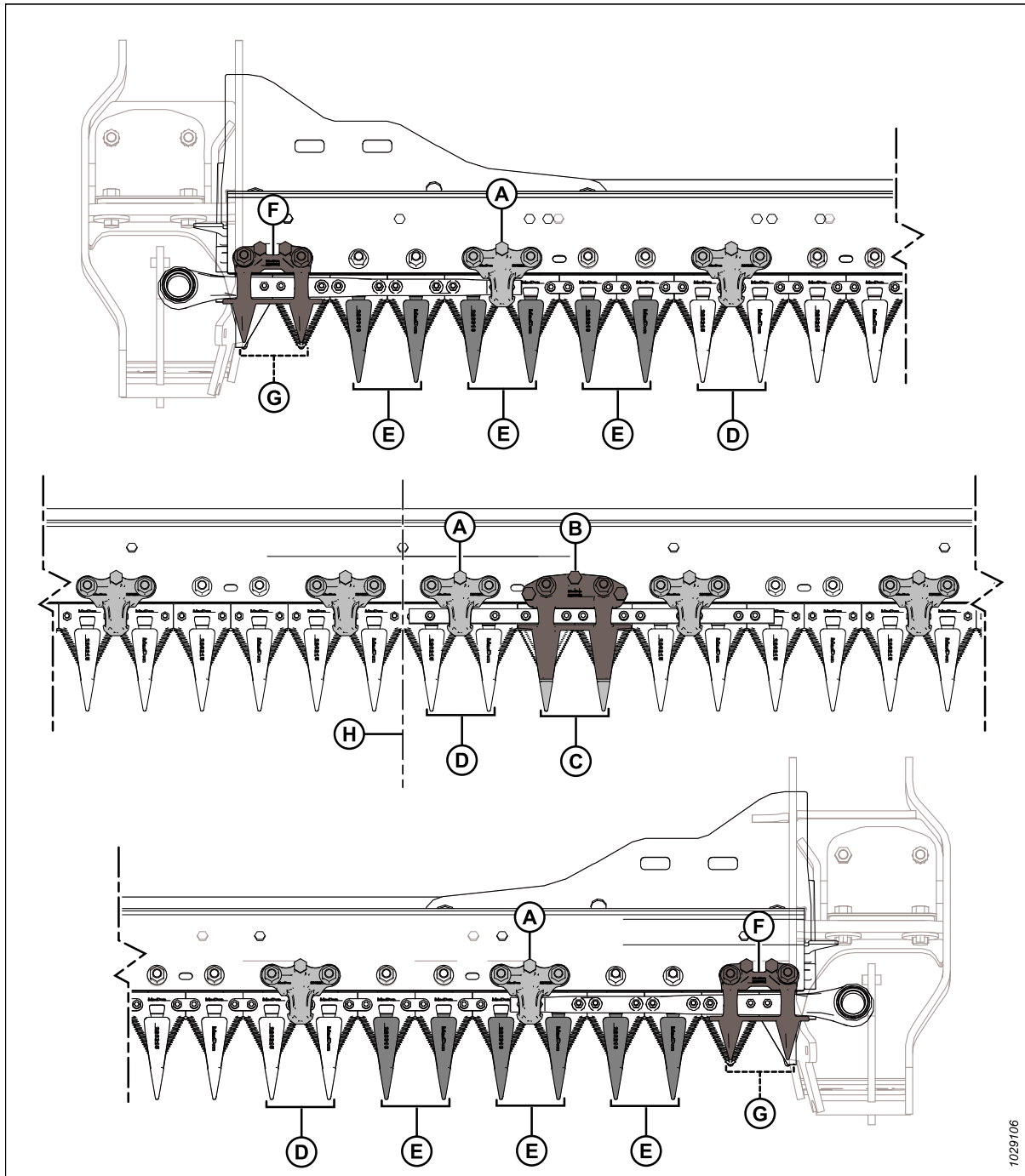
B - Pointed Knife Guard (MD #286315)

D - PlugFree™ Hold-Down (MD #286331)

F - Short Knife Guard (MD #286318)

*Pointed Knife Guard Configuration on Double-Knife Header – FD235*

Guards are configured differently on different headers. The illustration provided here shows pointed knife guards installed on double-knife headers.



**Figure 4.111: Pointed Knife Guard and Hold-Down Locations – FD235**

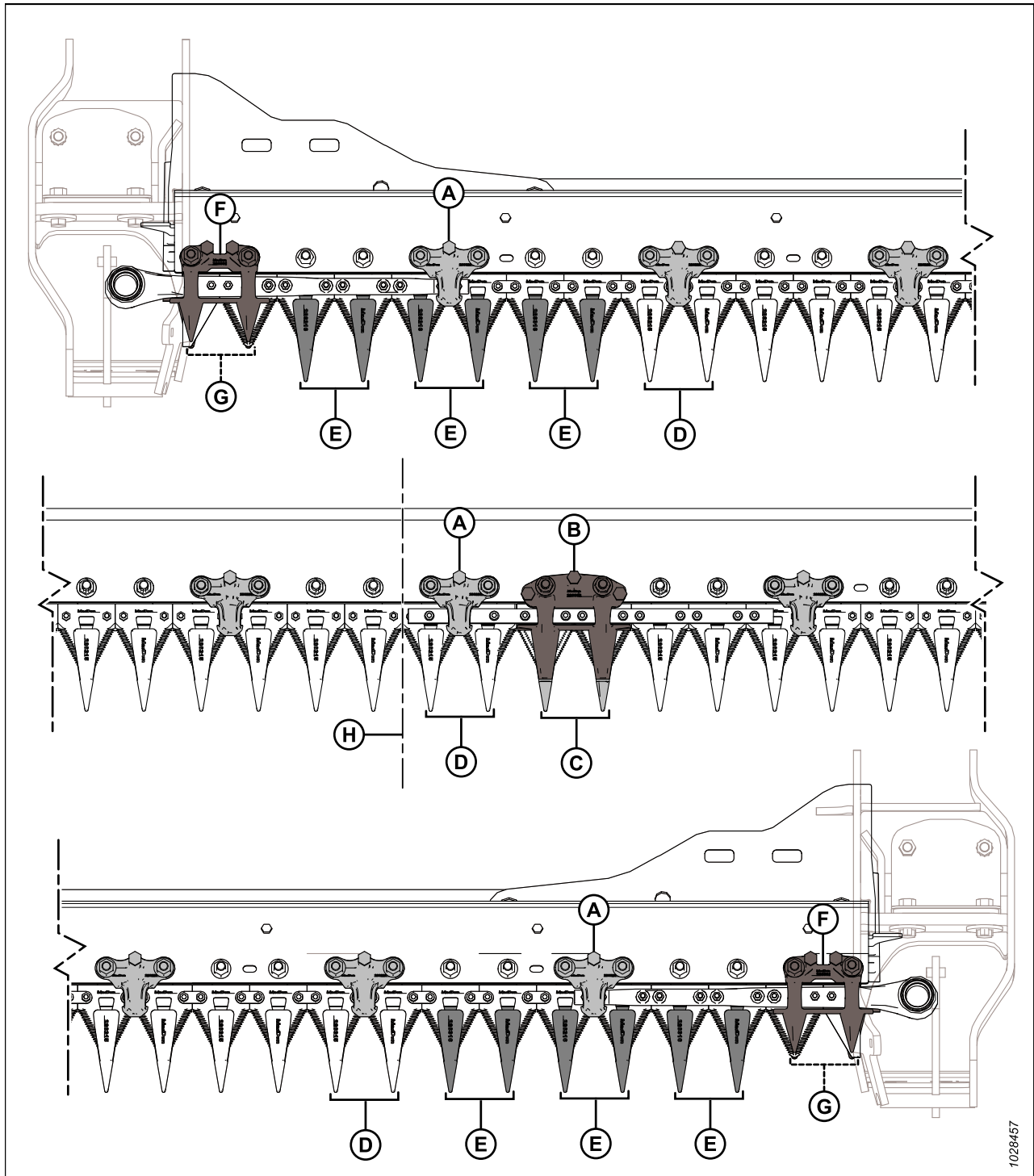
- |   |   |
|---|---|
| A - Pointed Hold-Down (MD #286329) <sup>90</sup>            | B - Pointed Center Hold-Down (MD #286332) |
| C - Pointed Center Knife Guard (MD #286317)                 | D - Pointed Knife Guard (MD #286315)      |
| E - Pointed End Knife Guard (without Wear Bar) (MD #286316) | F - PlugFree™ Hold-Down (MD #286331)      |
| G - PlugFree™ Guard (without Wear Bar) (MD #286319)         | H - Center of Header                      |

90. There should always be a hold-down on the guard to the right of the center guard, regardless of the configuration.



*Pointed Knife Guard Configuration on Double-Knife Header – FD240*

Knife guards help align the knife bar. Hold-downs hold the sections on the knife bar down against the knife guards to ensure proper cutting.



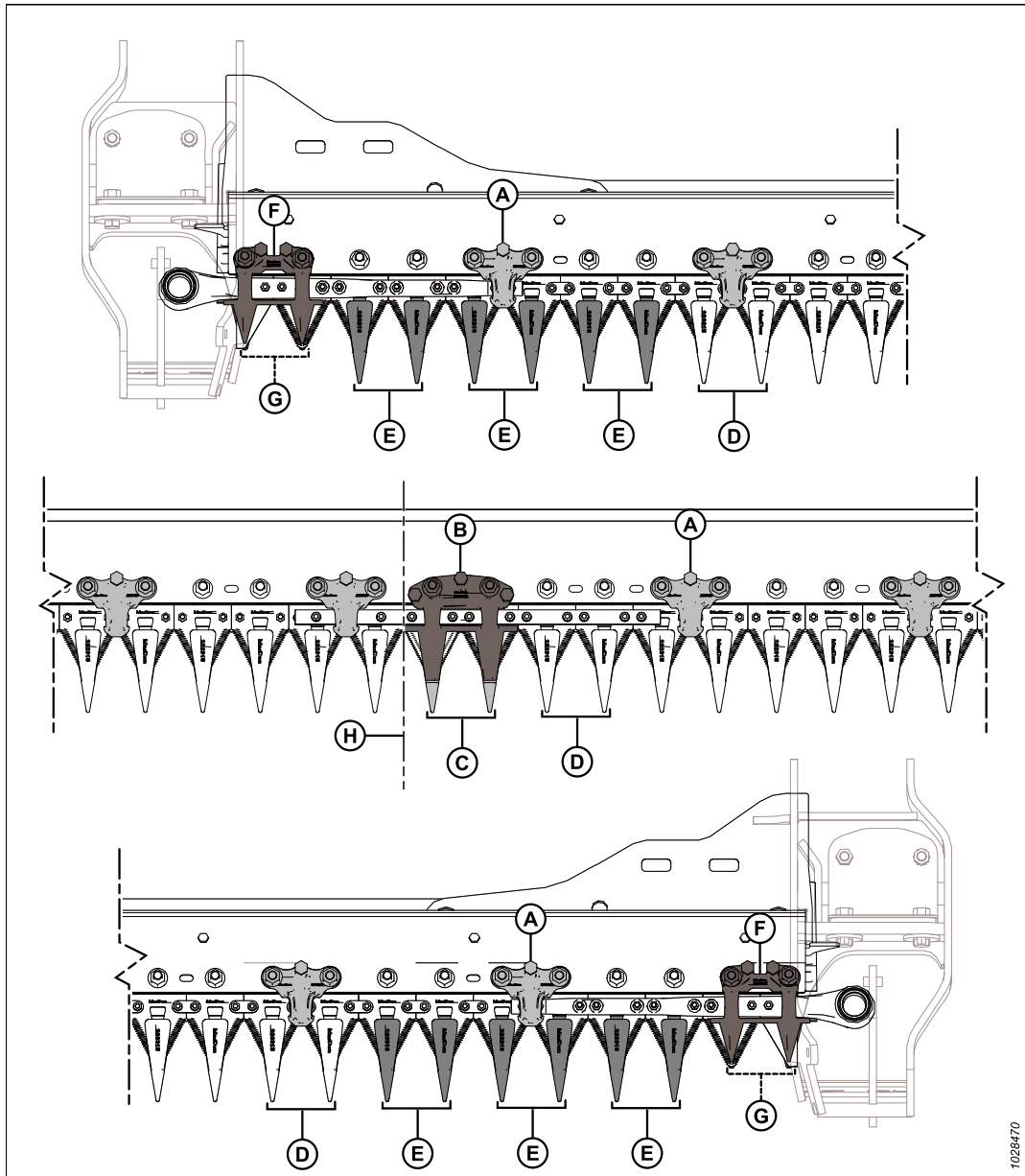
**Figure 4.112: Pointed Knife Guard and Hold-Down Locations – FD240 Double-Knife Header**

- A - Pointed Hold-Down (MD #286329)
- C - Pointed Center Knife Guard (MD #286317)
- E - Pointed End Knife Guard (without Wear Bar) (MD #286316)
- G - Short Knife Guard (without Wear Bar) (MD #286319)

- B - Pointed Center Hold-Down (MD #286332)
- D - Pointed Knife Guard (MD #286315)
- F - Short Knife Hold-Down (MD #286331)
- H - Center of Header

*Pointed Knife Guard Configuration on Double-Knife Header – FD241*

Guards are configured differently on different sized headers. The illustration provided here shows pointed knife guards installed on double-knife headers.



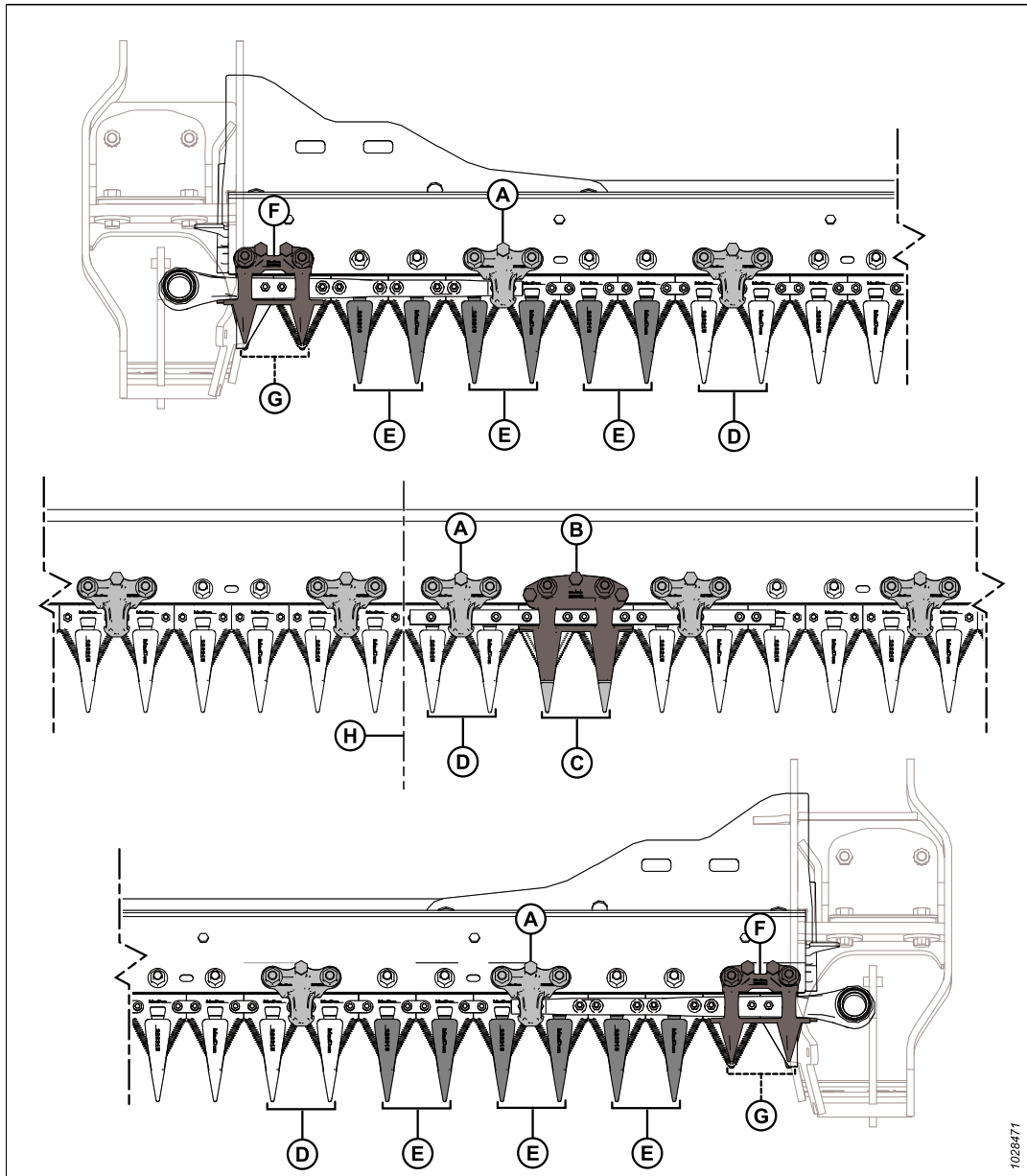
**Figure 4.113: Pointed Knife Guard and Hold-Down Locations**

- |   |   |
|---|---|
| A - Pointed Hold-Down (MD #286329) <sup>91</sup>            | B - Pointed Center Hold-Down (MD #286332) |
| C - Pointed Center Knife Guard (MD #286317)                 | D - Pointed Knife Guard (MD #286315)      |
| E - Pointed End Knife Guard (without Wear Bar) (MD #286316) | F - PlugFree™ Hold-Down (MD #286331)      |
| G - PlugFree™ Guard (without Wear Bar) (MD #286319)         | H - Center of Header                      |

91. There should always be a hold-down on the guard to the right of the center guard, regardless of the configuration.

*Pointed Knife Guard Configuration on Double-Knife Header – FD245*

Guards are configured differently on different sized headers. The illustration provided here shows pointed knife guards installed on double-knife headers.



**Figure 4.114: Pointed Knife Guard and Hold-Down Locations – FD245 Double-Knife Header**

A - Pointed Hold-Down (MD #286329)<sup>92</sup>

C - Pointed Center Knife Guard (MD #286317)

E - Pointed End Knife Guard (without Wear Bar) (MD #286316)

G - PlugFree™ Guard (without Wear Bar) (MD #286319)

B - Pointed Center Hold-Down (MD #286332)

D - Pointed Knife Guard (MD #286315)

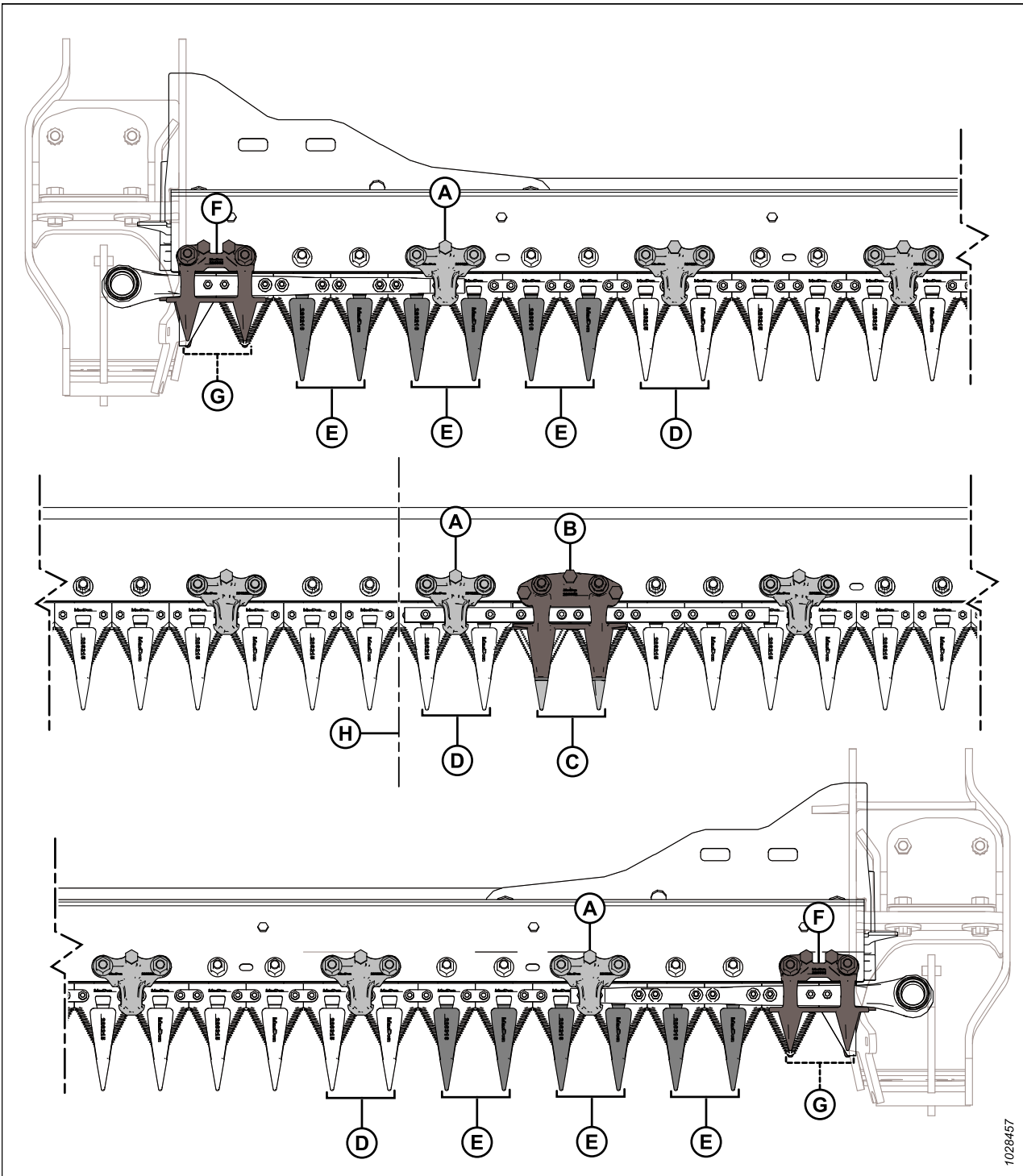
F - PlugFree™ Hold-Down (MD #286331)

H - Center of Header

92. There should always be a hold down on the guard to the right of the center guard, regardless of the pattern.

*Pointed Knife Guards Configuration on Double-Knife Header – FD250*

Guards are configured differently on different sized headers. The illustration provided here shows pointed knife guards installed on double-knife headers.



1028457

**Figure 4.115: Pointed Knife Guard and Hold-Down Locations – FD250 Double-Knife Header**

- |   |   |
|---|---|
| A - Pointed Hold-Down (MD #286329)                    | B - Pointed Center Hold-Down (MD #286332) |
| C - Pointed Center Knife Guard (MD #286317)           | D - Pointed Knife Guard (MD #286315)      |
| E - Pointed End Guard (without Wear Bar) (MD #286316) | F - Short Knife Hold-Down (MD #286331)    |
| G - Short Knife Guard (without Wear Bar) (MD #286319) | H - Center of Header                      |

### *Adjusting Knife Guards and Guard Bar*

If a knife guard or the guard bar is misaligned due to contact with a rock or obstruction, use the guard straightening tool to correct the alignment.

 **DANGER**

Ensure that all bystanders have cleared the area.

 **DANGER**

To prevent bodily injury or death from the unexpected start-up of the machine, always stop the engine and remove the key from the ignition before making adjustments to the machine.

 **WARNING**

To prevent bodily injury from the fall of a raised reel, always engage the reel safety props before going under the raised reel for any reason.

 **WARNING**

Wear heavy gloves when working around or handling knives.

1. Raise the reel fully.
2. Shut down the engine, and remove the key from the ignition.
3. Engage the reel safety props. For instructions, refer to [Engaging Reel Safety Props, page 39](#).

## MAINTENANCE AND SERVICING

4. To adjust the guard tips upward, position the guard straightening tool as shown and pull the tool up.

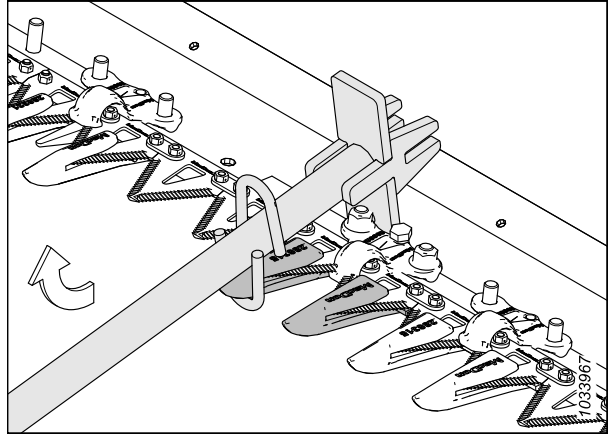


Figure 4.116: Upward Adjustment – Pointed Guard

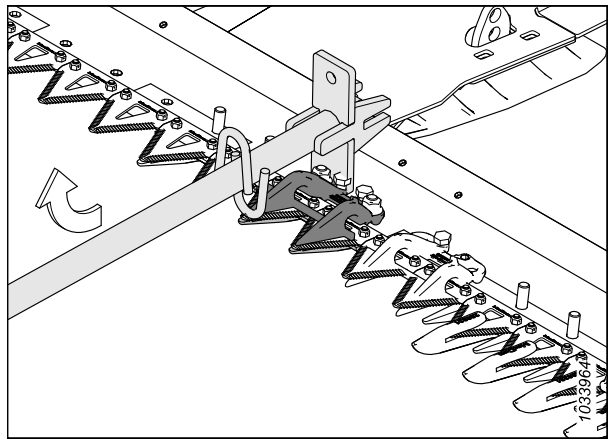


Figure 4.117: Upward Adjustment – Short Knife Guard

5. To adjust the guard tips downward, position the guard straightening tool as shown and push the tool down.

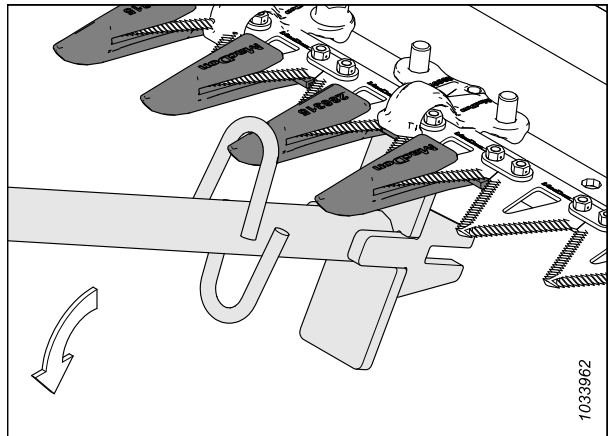


Figure 4.118: Downward Adjustment – Pointed Guard

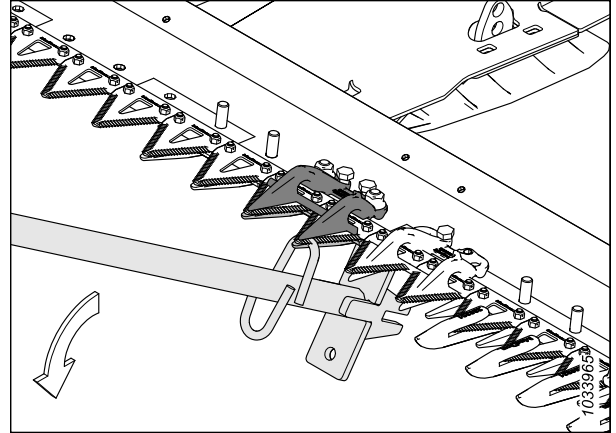


Figure 4.119: Downward Adjustment – Short Knife Guard

6. To adjust the guard bar, position the guard straightening tool as shown, then push down or pull up on the tool accordingly.

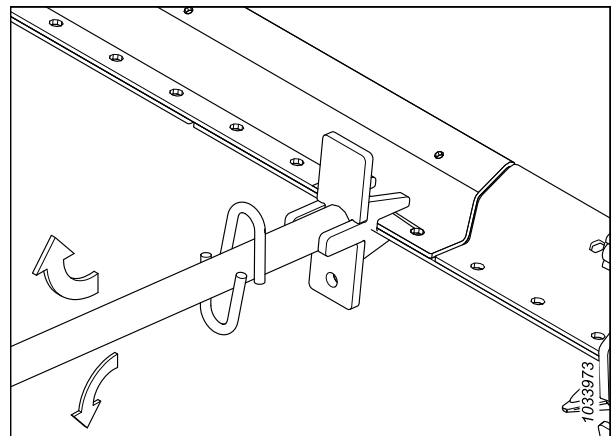


Figure 4.120: Guard Bar Adjustment – No Guards

### Replacing Pointed Knife Guards

The guards eventually become dull and need to be replaced. This procedure is for replacing standard guards and the special (drive side) guards closest to the knife drive motor.

#### **DANGER**

To prevent bodily injury or death from the unexpected start-up of the machine, always stop the engine and remove the key from the ignition before making adjustments to the machine.

#### **DANGER**

Ensure that all bystanders have cleared the area.

#### **WARNING**

To prevent bodily injury from the fall of a raised reel, always engage the reel safety props before going under the raised reel for any reason.

#### **WARNING**

Wear heavy gloves when working around or handling knives.



## MAINTENANCE AND SERVICING

### IMPORTANT:

When replacing the pointed knife guards, ensure that the hold-down sequence is correct for your header type and width. For more information, refer to [4.8.5 Pointed Knife Guards and Hold-Downs](#), page 634.

### NOTE:

A Four-Point Guard kit can be used to replace the knife guards. The four-point guard is ideal for use in rocky conditions, or for harvesting shatter-prone crops such as lentils. For more information, refer to the header parts catalog.

### IMPORTANT:

**Single- and double-knife headers:** On both ends of the header, position 1 (outboard guard) is a short knife guard. On the drive side(s) of the header, positions 2, 3, and 4 are pointed end knife guards (without wear bars). Starting at position 5, the remaining guards are pointed knife guards. Ensure that the proper replacement guards are installed at these locations.

### IMPORTANT:

**Double-knife headers:** A pointed center knife guard is installed where the two knives overlap. The pointed center knife guard has a slightly different replacement procedure. For instructions, refer to [Replacing Pointed Center Knife Guard – Double-Knife Header](#), page 647.

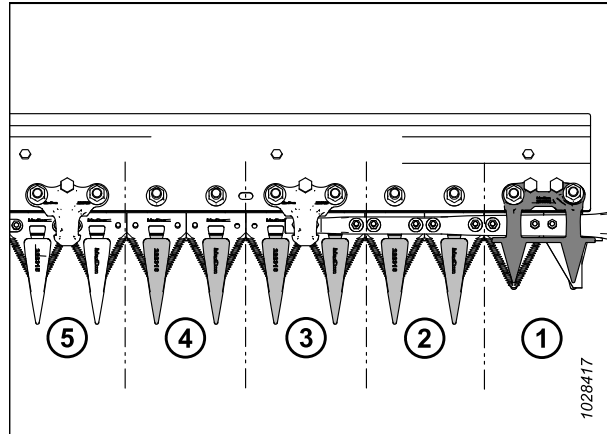


Figure 4.121: Drive Side Pointed Knife Guards

1. Raise the reel fully.
2. Shut down the engine, and remove the key from the ignition.
3. Engage the reel safety props. For instructions, refer to [Engaging Reel Safety Props](#), page 39.
4. Open the endshield. For instructions, refer to [Opening Header Endshields](#), page 41.
5. Rotate the flywheel attached to the knife drive box to adjust the knife position until the knife sections are spaced midway between the guards.
6. Close the endshield. For instructions, refer to [Closing Header Endshields](#), page 42.
7. Remove two nuts and bolts (B) securing pointed knife guard (A) and hold-down (C) (if applicable) to the cutterbar.
8. Remove pointed knife guard (A), hold-down (C), and the plastic wearplate. Discard the pointed knife guard.

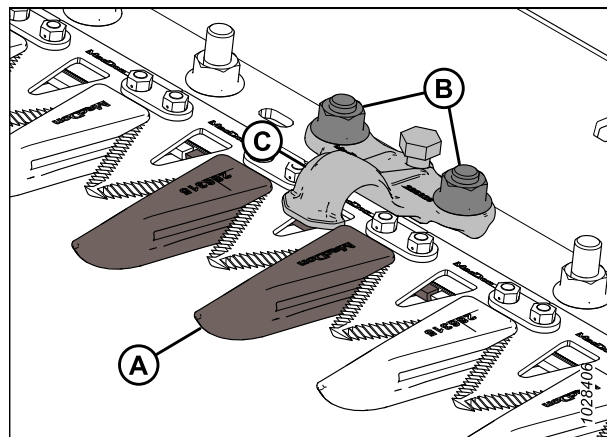


Figure 4.122: Pointed Knife Guards

9. Position plastic wearplate (A) and replacement pointed knife guard (B) under the cutterbar.

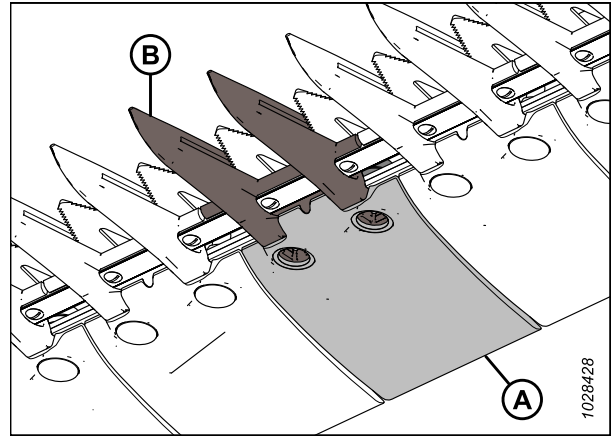


Figure 4.123: Pointed Knife Guard and Wearplate

10. Position hold-down (A) (if applicable), then loosen adjustment bolt (C) so that it does not protrude from the bottom of the hold-down.
11. Secure the pointed knife guard, the wearplate, and the hold-down (if applicable) with two bolts and nuts (B). Torque the nuts to 85 Nm (63 lbf-ft).
12. If there is a hold-down at this location, refer to [Adjusting Hold-Down – Pointed Knife Guards, page 646](#).

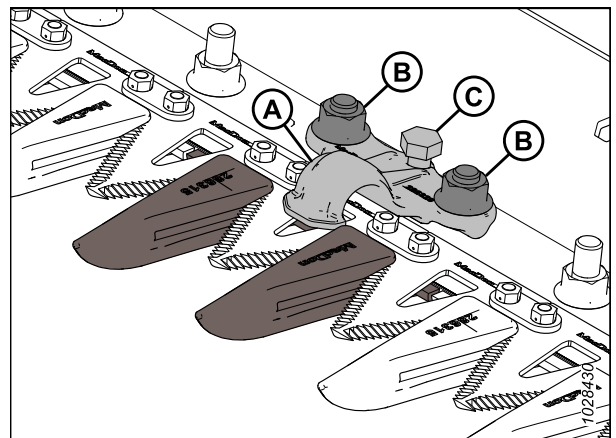


Figure 4.124: Pointed Knife Guards

### Checking Hold-Down – Pointed Knife Guards

The pointed knife guard hold-downs prevent the knife sections on the cutterbar from lifting off of the guards, while still allowing the knife to slide. Inspect the hold-downs to ensure that there is an adequate clearance between the hold-downs and knife sections.

This procedure is for standard hold-downs. To check the center hold-down on double-knife headers, refer to [Checking Center Hold-Down on Double-Knife Header – Pointed Knife Guards, page 650](#).

#### NOTE:

Align the guards before adjusting the hold-down. For instructions, refer to [Adjusting Knife Guards and Guard Bar, page 641](#).

#### DANGER

To prevent bodily injury or death from the unexpected start-up of the machine, always stop the engine and remove the key from the ignition before making adjustments to the machine.

#### DANGER

Ensure that all bystanders have cleared the area.

**WARNING**

To prevent bodily injury from the fall of a raised reel, always engage the reel safety props before going under the raised reel for any reason.

**WARNING**

Wear heavy gloves when working around or handling knives.

1. Raise the reel fully.
2. Shut down the engine, and remove the key from the ignition.
3. Engage the reel safety props. For instructions, refer to *Engaging Reel Safety Props, page 39*.
4. Open the endshield. For instructions, refer to *Opening Header Endshields, page 41*.
5. Rotate the flywheel attached to the knife drive box to position knife section (A) under hold-down (B), and between guard (C).
6. Push down on knife section (A) with approximately 44 N (10 lbf) of force, and use a feeler gauge to measure the clearance between hold-down (B) and the knife section. Ensure the clearance is 0.1–0.5 mm (0.004–0.020 in.).
7. If adjustment is necessary, refer to *Adjusting Hold-Down – Pointed Knife Guards, page 646*.
8. Close the endshield. For instructions, refer to *Closing Header Endshields, page 42*.

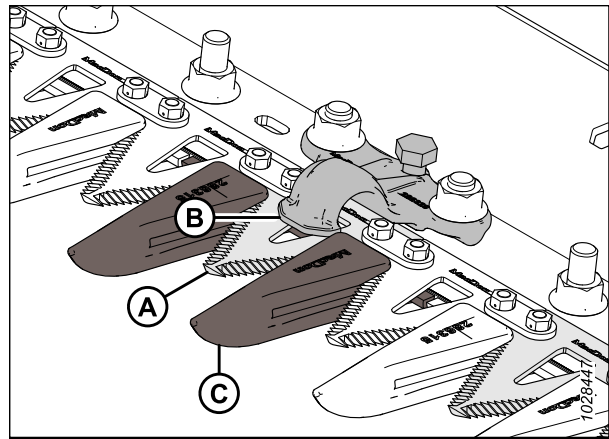


Figure 4.125: Pointed Guard Hold-Down

*Adjusting Hold-Down – Pointed Knife Guards*

If a pointed or four-point knife guard hold-down is binding the knife, adjust the hold-down.

This procedure applies to standard hold-downs. To adjust the center hold-down on double-knife headers, refer to *Adjusting Center Hold-Down on Double-Knife Header – Pointed Knife Guards, page 651*.

**DANGER**

To prevent bodily injury or death from the unexpected start-up of the machine, always stop the engine and remove the key from the ignition before making adjustments to the machine.

**DANGER**

Ensure that all bystanders have cleared the area.

**WARNING**

To prevent bodily injury from the fall of a raised reel, always engage the reel safety props before going under the raised reel for any reason.

**WARNING**

Wear heavy gloves when working around or handling knives.

## MAINTENANCE AND SERVICING

1. Align the guards. For instructions, refer to [Adjusting Knife Guards and Guard Bar, page 641](#).
2. Raise the reel fully.
3. Shut down the engine, and remove the key from the ignition.
4. Engage the reel safety props. For instructions, refer to [Engaging Reel Safety Props, page 39](#).
5. Adjust the hold-down clearance as follows:
  - To lower the front of hold-down (A) and decrease the clearance, rotate adjuster bolt (B) clockwise.
  - To raise the front of hold-down (A) and increase the clearance, rotate adjuster bolt (B) counterclockwise.

### NOTE:

For larger adjustments, it may be necessary to loosen nuts (C) before rotating adjuster bolt (B). After adjustment, retighten the nuts to 85 Nm (63 lbf-ft).

6. Check the hold-down clearance. For instructions, refer to [Checking Hold-Down – Pointed Knife Guards, page 645](#).

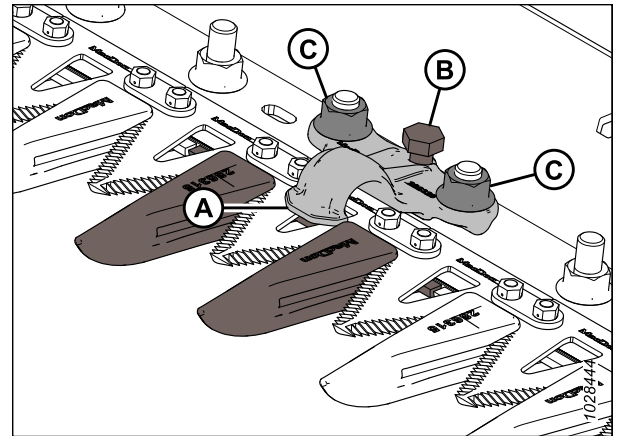


Figure 4.126: Pointed Hold-Down

7. Run the engine at a low idle and listen for noise caused by insufficient clearance. Repeat Step 5, [page 647](#) to Step 6, [page 647](#) if necessary.

### IMPORTANT:

An insufficient hold-down clearance will cause the knife and the guards to overheat.

### Replacing Pointed Center Knife Guard – Double-Knife Header

The guard at the center of a double-knife header (where the two knives overlap) requires a different replacement procedure than a pointed knife guard.

### DANGER

To prevent bodily injury or death from the unexpected start-up of the machine, always stop the engine and remove the key from the ignition before making adjustments to the machine.

### DANGER

Ensure that all bystanders have cleared the area.

### WARNING

To prevent bodily injury from the fall of a raised reel, always engage the reel safety props before going under the raised reel for any reason.

### WARNING

Wear heavy gloves when working around or handling knives.

1. Raise the reel fully.
2. Shut down the engine, and remove the key from the ignition.
3. Engage the reel safety props. For instructions, refer to [Engaging Reel Safety Props, page 39](#).

## MAINTENANCE AND SERVICING

4. Remove two nuts and bolts (C) securing guard (A) and hold-down (B) to the cutterbar.
5. Remove guard (A), plastic wearplate, and hold-down (B).

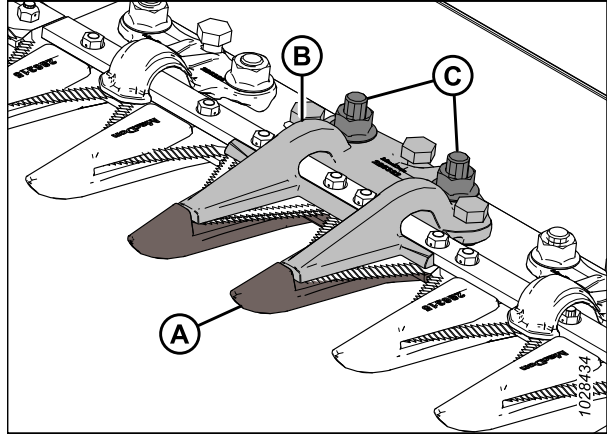


Figure 4.127: Pointed Center Knife Guard

### IMPORTANT:

Ensure that the replacement guard is the correct guard with offset cutting surfaces (A).

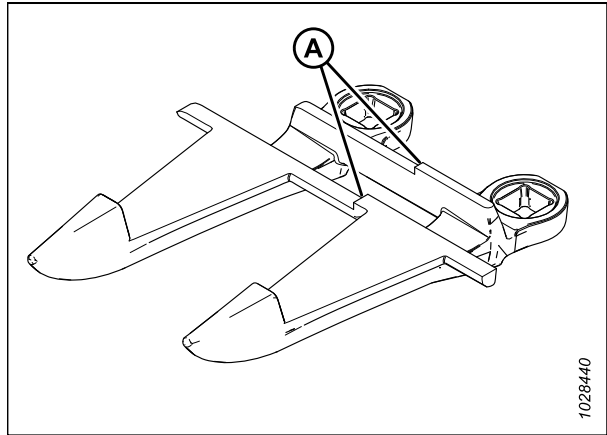


Figure 4.128: Pointed Center Knife Guard

6. Before installing the new pointed center knife guard, ensure that overlap shim (A) is present under the cutterbar, and that the thick end of the shim is positioned under the center guard.

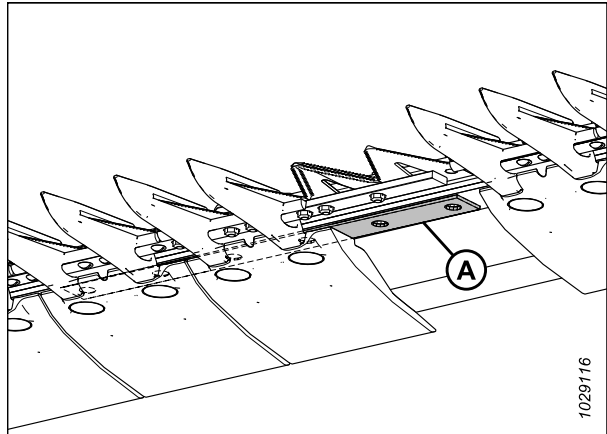


Figure 4.129: Cutterbar

## MAINTENANCE AND SERVICING

7. Position plastic wearplate (A) and new guard (B) under the cutterbar.

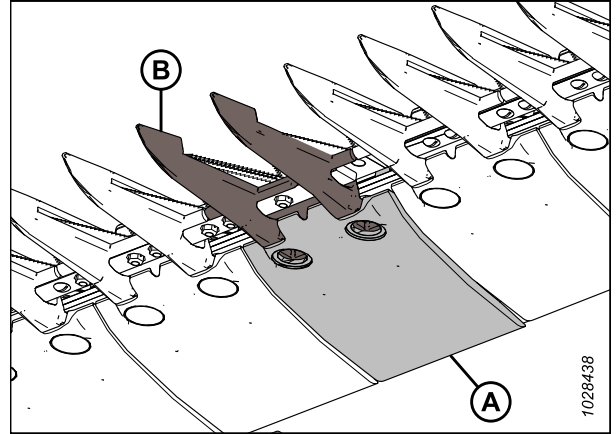


Figure 4.130: Pointed Center Knife Guard and Wearplate

8. Install three adjustment bolts (A) so that they are protruding 4 mm (5/32 in.) from the bottom of pointed center hold-down (B).
9. Position center hold-down (B) onto the cutterbar.

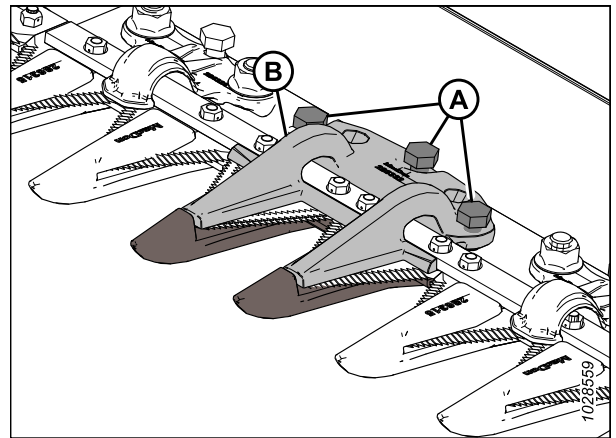


Figure 4.131: Pointed Center Knife Guard

10. Secure pointed center hold-down (A) with two bolts and nuts (B), but do **NOT** tighten the hardware at this time.

### IMPORTANT:

Hold-down (A) must accommodate two overlapping knives at the center guard location. Ensure that the proper replacement guard is installed at this location.

11. Adjust the hold-down until the clearance is acceptable.
  - For adjustment instructions, refer to [Adjusting Center Hold-Down on Double-Knife Header – Pointed Knife Guards](#), page 651.
  - For clearance specifications, refer to [Checking Center Hold-Down on Double-Knife Header – Pointed Knife Guards](#), page 650.

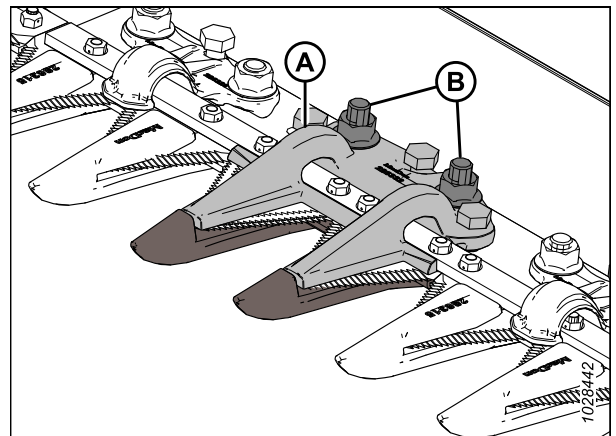


Figure 4.132: Pointed Center Knife Guard

12. Torque nuts (B) to 85 Nm (63 lbf-ft).

### Checking Center Hold-Down on Double-Knife Header – Pointed Knife Guards

The pointed center knife guard hold-down prevents the center knife section on the cutterbar from lifting off of the guard while still allowing the knives to slide. Inspect the center hold-down to ensure that there is adequate clearance between the hold-down and the center knife section.

#### DANGER

To prevent bodily injury or death from the unexpected start-up of the machine, always stop the engine and remove the key from the ignition before making adjustments to the machine.

#### DANGER

Ensure that all bystanders have cleared the area.

#### WARNING

To prevent bodily injury from the fall of a raised reel, always engage the reel safety props before going under the raised reel for any reason.

#### WARNING

Wear heavy gloves when working around or handling knives.

1. Raise the reel fully.
2. Shut down the engine, and remove the key from the ignition.
3. Engage the reel safety props. For instructions, refer to *Engaging Reel Safety Props, page 39*.
4. Open the endshield. For instructions, refer to *Opening Header Endshields, page 41*.
5. Rotate the flywheel attached to the knife drive box to position the knife fully inboard until the knife sections are under hold-down (A). Repeat this step to move the other knife.
6. Push down on the knife section with approximately 44 N (10 lbf) of force, and use a feeler gauge to measure the clearance between hold-down (A) and the knife section. Ensure that the clearance is as follows:
  - At tip (B) of hold-down: 0.1–0.5 mm (0.004–0.020 in.)
  - At rear (C) of hold-down: 0.1–1.0 mm (0.004–0.040 in.)
7. If adjustment is required, refer to *Adjusting Center Hold-Down on Double-Knife Header – Pointed Knife Guards, page 651*.
8. After tightening nuts (D), recheck the clearance and adjust if necessary.
9. Close the endshield. For instructions, refer to *Closing Header Endshields, page 42*.

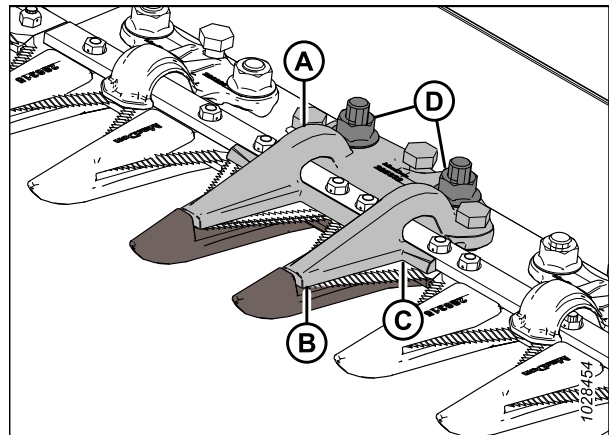


Figure 4.133: Pointed Center Hold-Down



*Adjusting Center Hold-Down on Double-Knife Header – Pointed Knife Guards*

If the pointed center knife guard hold-down is binding the knife, adjust it.

**⚠ DANGER**

To prevent bodily injury or death from the unexpected start-up of the machine, always stop the engine and remove the key from the ignition before making adjustments to the machine.

**⚠ DANGER**

Ensure that all bystanders have cleared the area.

**⚠ WARNING**

To prevent bodily injury from the fall of a raised reel, always engage the reel safety props before going under the raised reel for any reason.

**⚠ WARNING**

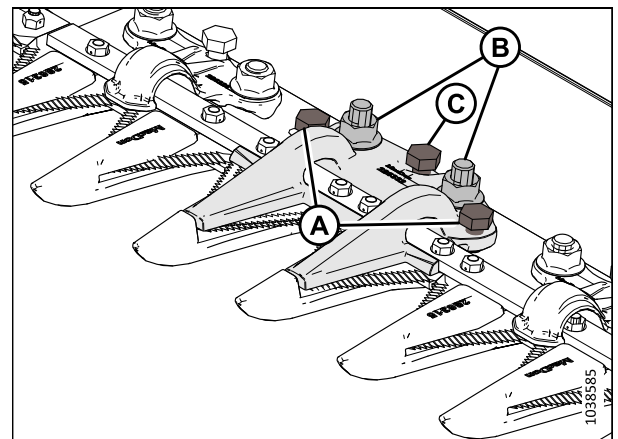
Wear heavy gloves when working around or handling knives.

1. Raise the reel fully.
2. Shut down the engine, and remove the key from the ignition.
3. Engage the reel safety props. For instructions, refer to *Engaging Reel Safety Props, page 39*.
4. Loosen mounting hardware (B).
5. Adjust the hold-down clearance as follows:
  - To increase the clearance, rotate adjuster bolts (A) clockwise (tighten the bolts).
  - To decrease the clearance, rotate adjuster bolts (A) counterclockwise (loosen the bolts).
6. To adjust the clearance at the hold-down tip only, use adjustment bolt (C) as follows:
  - To increase the clearance, rotate adjuster bolt (C) counterclockwise (loosen the bolts).
  - To decrease the clearance, rotate adjuster bolt (C) clockwise (tighten the bolts).
7. Tighten nuts (B) to 85 Nm (63 lbf-ft).
8. Run the engine at a low idle, and listen for noise caused by insufficient clearance.

**IMPORTANT:**

An insufficient hold-down clearance will cause the knife and the guards to overheat.

9. Check the center guard clearance. For more information, refer to *Checking Center Hold-Down on Double-Knife Header – Pointed Knife Guards, page 650*.

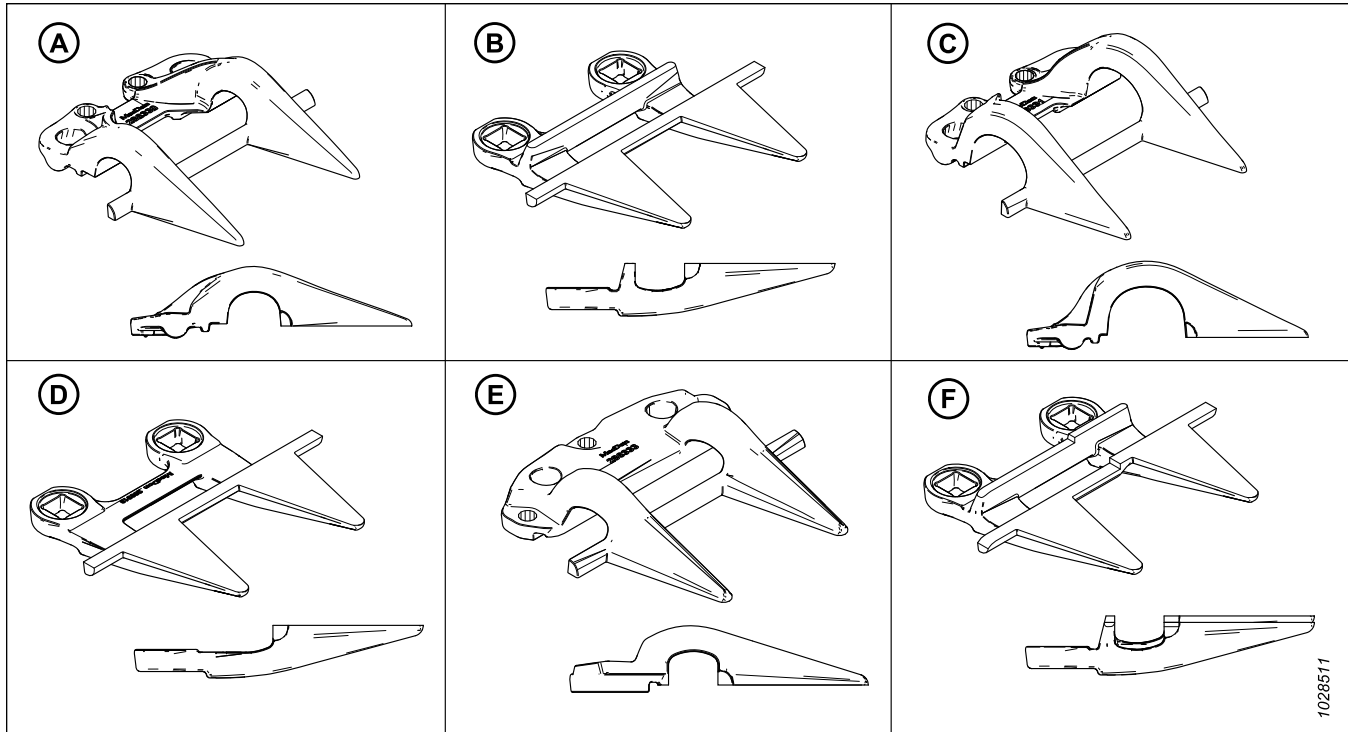


**Figure 4.134: Pointed Center Hold-Down**

### 4.8.6 Short Knife Guards and Hold-Downs

Short knife guards make the knife less likely to plug in wet or muddy conditions and in tough crops such as grasses and canola.

The following knife guards and hold-downs are used in short knife guard configurations:



**Figure 4.135: Guard and Hold-Down Types used in Short Knife Guard Configurations**

- A - PlugFree™ Hold-Down (MD #286330)
- C - PlugFree™ End Hold-Down (MD #286331)<sup>93</sup>
- E - PlugFree™ Center Hold-Down (MD #286333)<sup>95</sup>

- B - PlugFree™ Knife Guard (MD #286318)
- D - PlugFree™ End Knife Guard (without Wear Bar) (MD #286319)<sup>94</sup>
- F - PlugFree™ Center Knife Guard (MD #286320)<sup>95</sup>

The guards are configured differently on different headers. When replacing the short knife guards and the hold-downs, ensure that you use the correct sequence for your header. The following list will guide you to the different guard configurations:

- [Short Knife Guard Configuration on Single-Knife Headers, page 653](#)
- [Short Knife Guard Configuration on Double-Knife Headers – All Sizes Except D241, page 654](#)
- [Short Knife Guard Configuration on Double-Knife Headers – FD241, page 655](#)

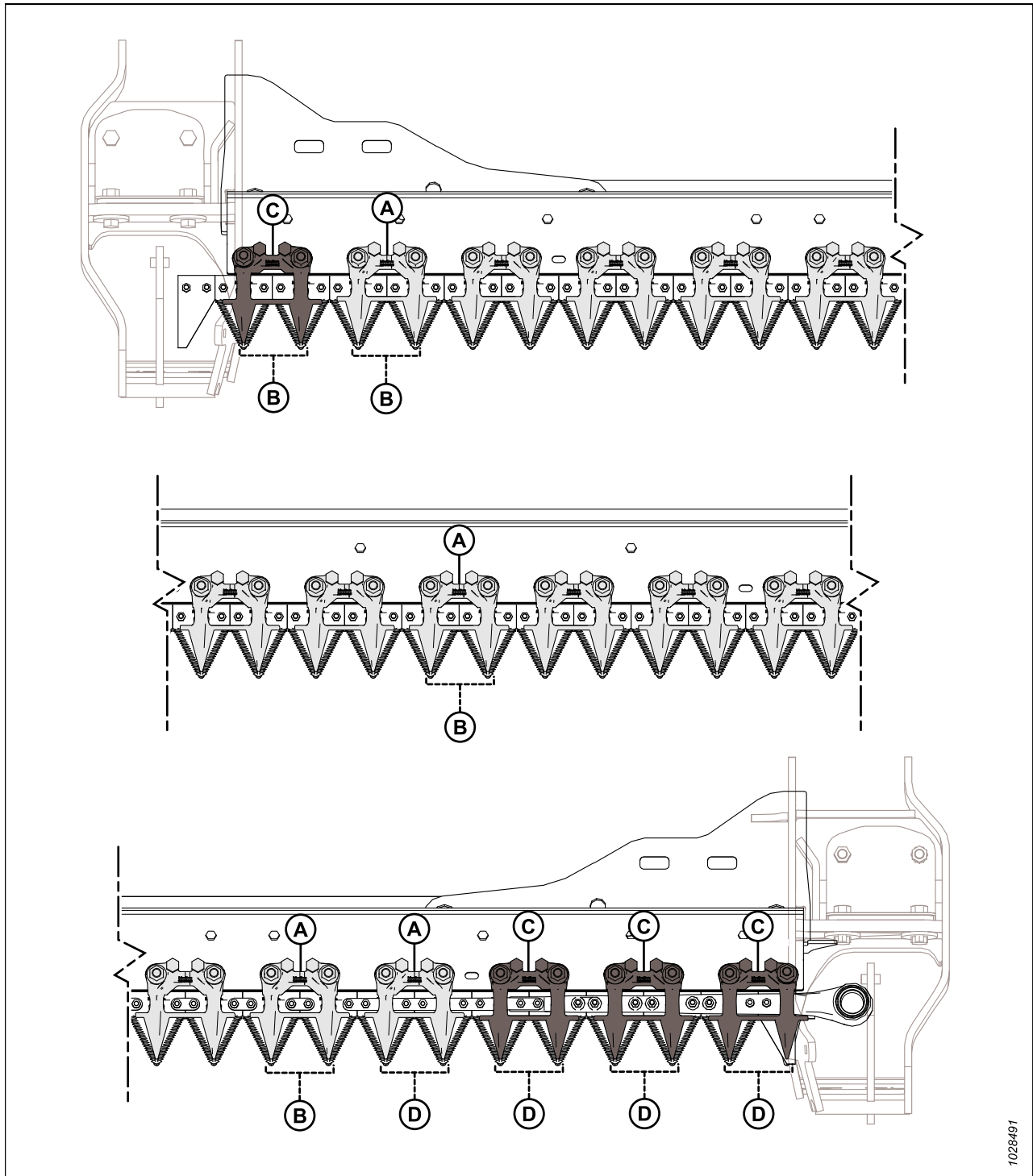
93. Installed in positions 1–3 on the drive side(s); installed in position 1 at the right end of single-knife headers.

94. Installed in positions 1–4 on the drive side(s). Single-knife headers use a standard guard on the right end of the header.

95. Double-knife headers only.

*Short Knife Guard Configuration on Single-Knife Headers*

The guards are configured differently on different sized headers. The illustration provided here shows short knife guards installed on single-knife headers.



**Figure 4.136: Short Knife Guard and Hold-Down Locations – Single-Knife Headers**

A - PlugFree™ Hold-Down (MD #286330)

C - PlugFree™ End Hold-Down (x4) (MD #286331)

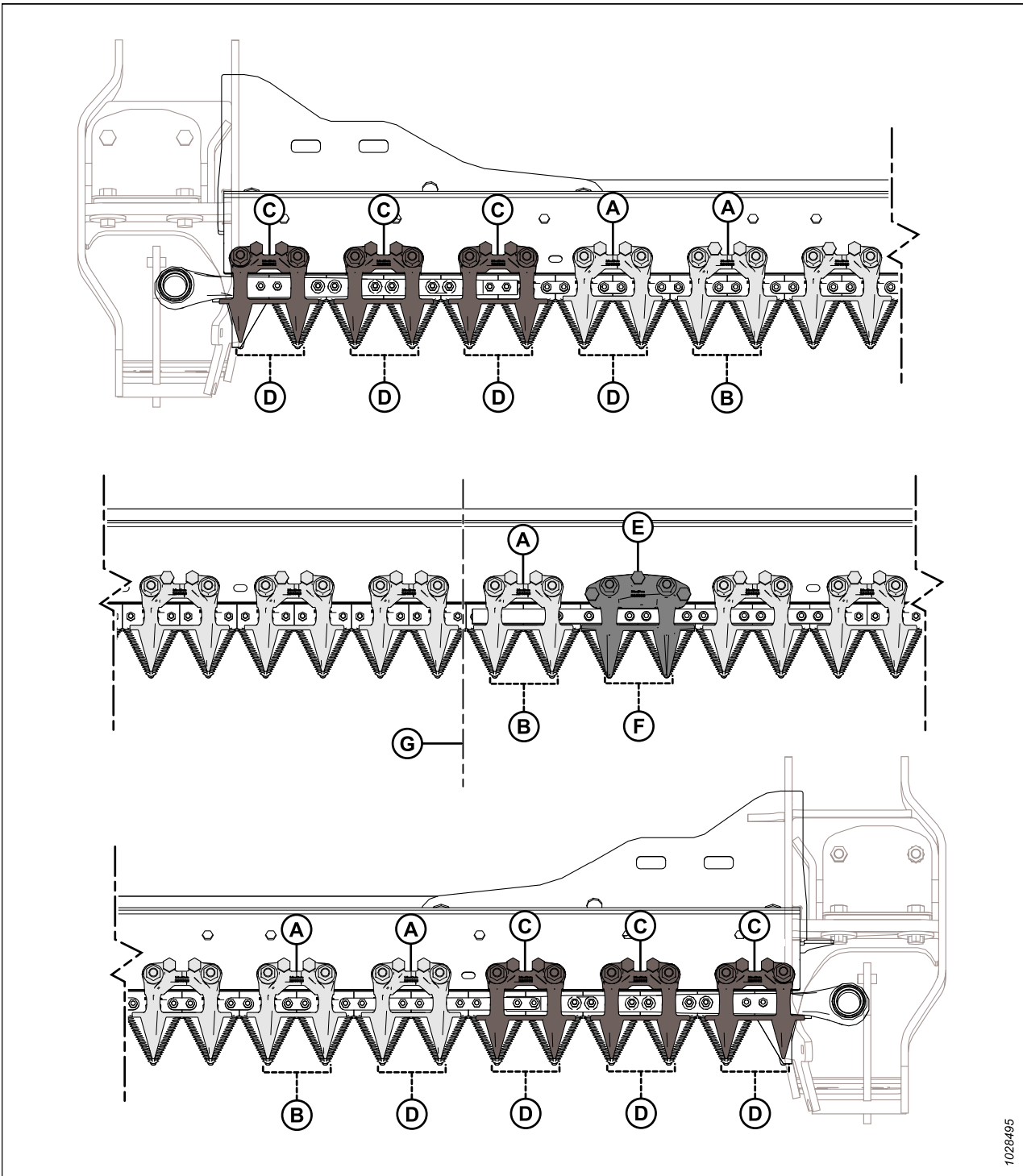
B - PlugFree™ Guard (MD #286318)

D - PlugFree™ End Knife Guard (without Wear Bar) (x5) (MD #286319)

1028491

*Short Knife Guard Configuration on Double-Knife Headers – All Sizes Except D241*

The guards are configured differently on different sized headers. The illustration provided here shows short knife guards installed on double-knife headers.



1028495

**Figure 4.137: Short Knife Guard and Hold-Down Locations – Double-Knife Headers**

- |   |  |
|---|--|
| A - PlugFree™ Hold-Down (MD #286330)          | B - PlugFree™ Guard (MD #286318)                                   |
| C - PlugFree™ End Hold-Down (x6) (MD #286331) | D - PlugFree™ End Knife Guard (without Wear Bar) (x8) (MD #286319) |
| E - PlugFree™ Center Hold-Down (MD #286333)   | F - PlugFree™ Center Knife Guard (MD #286320)                      |
| G - Center of Header                          |  |

Short Knife Guard Configuration on Double-Knife Headers – FD241

The guards are configured differently on different sized headers. The illustration provided here shows short knife guards installed on double-knife headers.

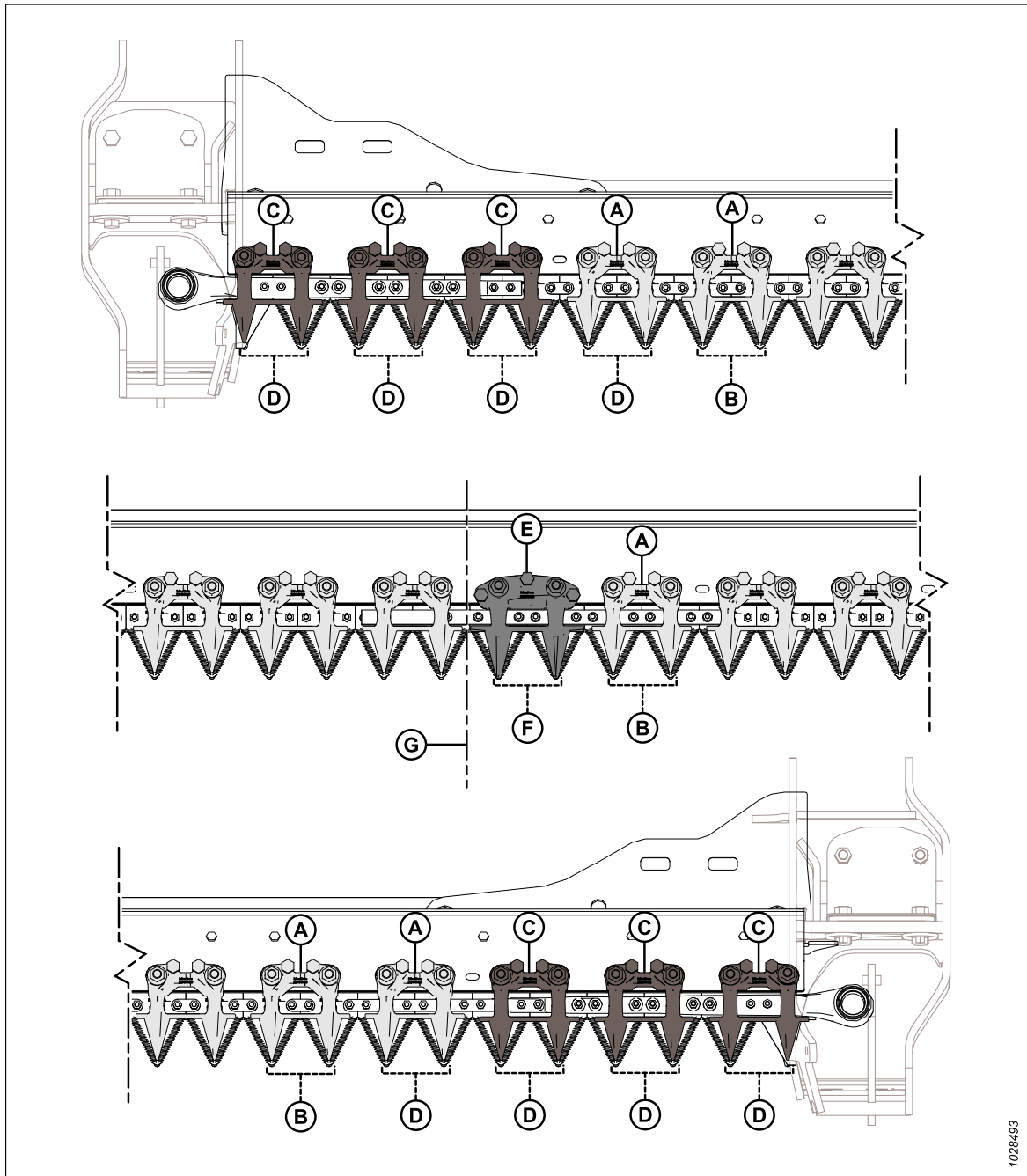


Figure 4.138: Short Knife Guard and Hold-Down Locations

- A - PlugFree™ Hold-Down (MD #286330)
- C - PlugFree™ End Hold-Down (x6) (MD #286331)
- E - PlugFree™ Center Hold-Down (MD #286333)
- G - Center of Header

- B - PlugFree™ Guard (MD #286318)
- D - PlugFree™ End Knife Guard (without Wear Bar) (x8) (MD #286319)
- F - PlugFree™ Center Knife Guard (MD #286320)

### *Replacing Short Knife Guards or End Knife Guards*

Short knife guards or end knife guards are installed at the factory and make the knife less likely to plug in wet or muddy conditions or in tough crops such as grasses and canola.

#### **DANGER**

To prevent bodily injury or death from the unexpected start-up of the machine, always stop the engine and remove the key from the ignition before making adjustments to the machine.

#### **DANGER**

Ensure that all bystanders have cleared the area.

#### **WARNING**

To prevent bodily injury from the fall of a raised reel, always engage the reel safety props before going under the raised reel for any reason.

#### **WARNING**

Wear heavy gloves when working around or handling knives.

#### **IMPORTANT:**

The center knife guard for a double-knife header has a slightly different replacement procedure. For instructions, refer to [Replacing Center Knife Guard – Double-Knife Headers, page 660](#).

To replace a short knife guard or an end knife guard, follow these steps:

1. Raise the reel fully.
2. Shut down the engine, and remove the key from the ignition.
3. Engage the reel safety props. For instructions, refer to [Engaging Reel Safety Props, page 39](#).
4. Remove nuts and bolts (A) securing short knife guard (B) and hold-down (C) to the cutterbar.
5. Remove short knife guard (B), hold-down (C), and the plastic wearplate.

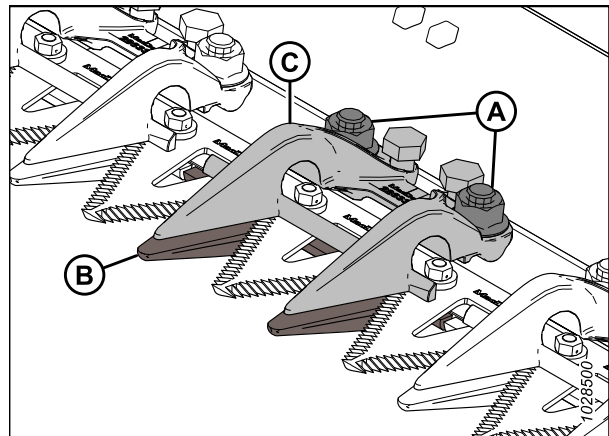
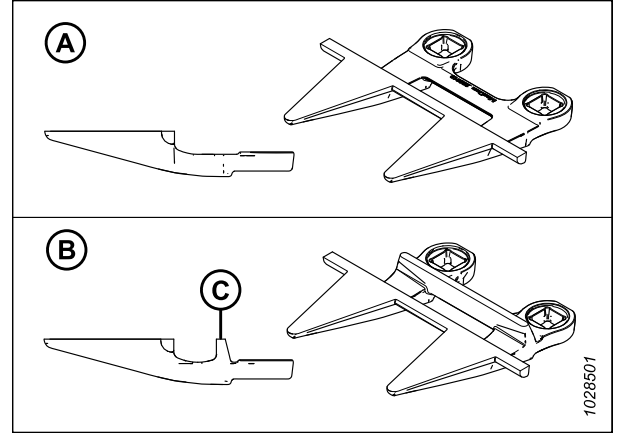


Figure 4.139: Short Knife Guards

**IMPORTANT:**

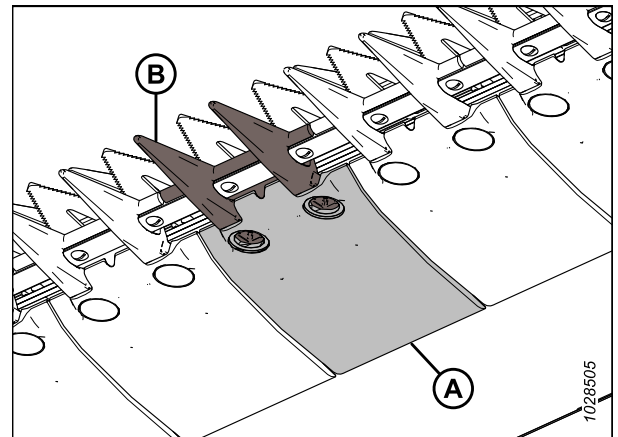
The end knife guards are the first four knife guards (A) on the drive sides of the header and they do **NOT** have wear bars. Install the proper replacement knife guards at these locations.



**Figure 4.140: End Knife Guard and Short Knife Guards**

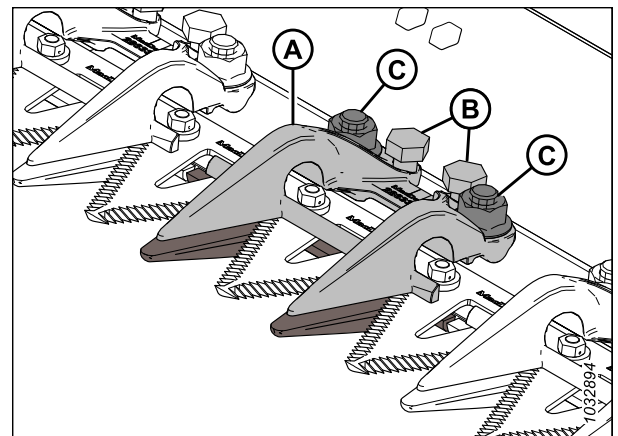
A - Plug Free™ End Knife Guard (MD #286319)  
 B - Plug Free™ Guard (with Wear Bar [C]) (MD #286318)

6. Position plastic wearplate (A) and replacement short knife guard (B) under the cutterbar.



**Figure 4.141: Short Knife Guard and Wearplate**

7. Position hold-down (A) and loosen adjustment bolts (B) so that they do not protrude below the hold-down.
8. Secure the short knife guard, the wearplate, and the hold-down with bolts and nuts (C). Do **NOT** tighten the nuts.
9. Adjust the hold-down until the clearance is acceptable.
  - For adjustment instructions, refer to [Adjusting Hold-Down – Short Knife Guards, page 659](#).
  - For clearance specifications, refer to [Checking Hold-Down – Short Knife Guards, page 658](#).
10. Tighten nuts (C) to 85 Nm (63 lbf-ft).



**Figure 4.142: Short Knife Guard**



## MAINTENANCE AND SERVICING

11. Check the clearance.
  - If the clearance is acceptable, the installation of the hold-down is complete.
  - If the clearance is unacceptable, repeat Step 9, page 657 to Step 11, page 658.
12. Disengage the reel safety props. For instructions, refer to *Disengaging Reel Safety Props, page 40*.

### Checking Hold-Down – Short Knife Guards

The short knife guard hold-downs prevent the knife sections on the cutterbar from lifting off of the guards while still allowing the knife to slide. Inspect the hold-downs to ensure that there is adequate clearance between the hold-downs and knife sections.

To check the center hold-down on double-knife headers, refer to *Checking Center Hold-Down on Double-Knife Headers – Short Knife Guards, page 662*.

### DANGER

To prevent bodily injury or death from the unexpected start-up of the machine, always stop the engine and remove the key from the ignition before making adjustments to the machine.

### DANGER

Ensure that all bystanders have cleared the area.

### WARNING

To prevent bodily injury from the fall of a raised reel, always engage the reel safety props before going under the raised reel for any reason.

### WARNING

Wear heavy gloves when working around or handling knives.

1. Raise the reel fully.
2. Shut down the engine, and remove the key from the ignition.
3. Engage the reel safety props. For instructions, refer to *Engaging Reel Safety Props, page 39*.
4. Rotate the flywheel attached to the knife drive box to position the knife inboard until the knife sections are under hold-down (A).
5. Push down on the knife section with approximately 44 N (10 lbf) of force and use a feeler gauge to measure the clearance between the tip of hold-down (B) and the knife section. Ensure that the clearance is 0.1–0.5 mm (0.004–0.020 in.).
6. If adjustment is required, refer to *Adjusting Hold-Down – Short Knife Guards, page 659*.

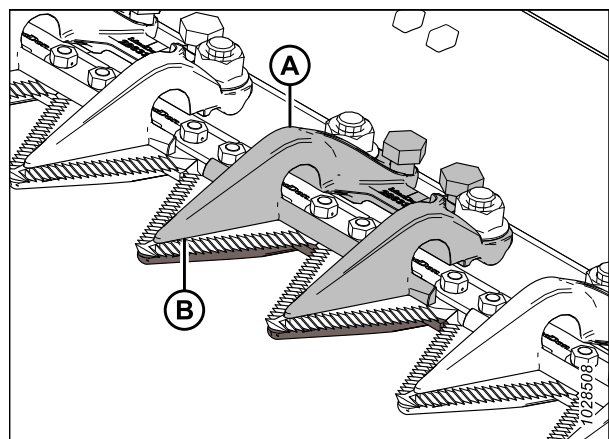


Figure 4.143: Short Knife Guards

### Adjusting Hold-Down – Short Knife Guards

If a short knife guard hold-down is binding its knife, adjust the hold-down.

To adjust the center hold-down on double-knife headers, refer to [Adjusting Center Hold-Down – Short Knife Guards, page 663](#).

#### DANGER

To prevent bodily injury or death from the unexpected start-up of the machine, always stop the engine and remove the key from the ignition before making adjustments to the machine.

#### DANGER

Ensure that all bystanders have cleared the area.

#### WARNING

To prevent bodily injury from the fall of a raised reel, always engage the reel safety props before going under the raised reel for any reason.

#### WARNING

Wear heavy gloves when working around or handling knives.

1. Raise the reel fully.
2. Shut down the engine, and remove the key from the ignition.
3. Engage the reel safety props. For instructions, refer to [Engaging Reel Safety Props, page 39](#).
4. Adjust the hold-down clearance as follows:
  - To decrease the clearance, rotate adjuster bolts (A) clockwise.
  - To increase the clearance, rotate adjuster bolts (A) counterclockwise.

**NOTE:**

For larger adjustments, loosen nuts (B) before rotating adjuster bolts (A). After adjustment, retighten the nuts to 85 Nm (63 lbf·ft).

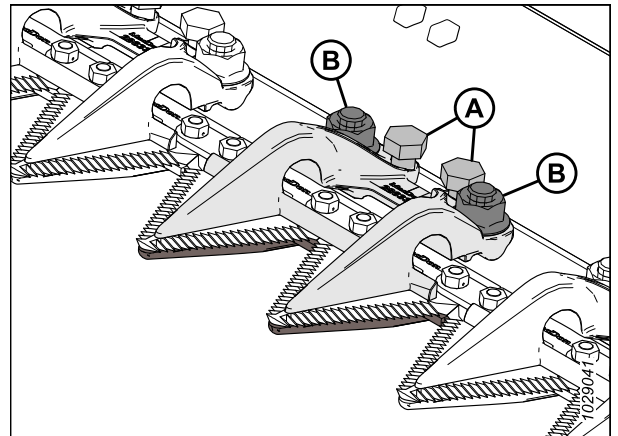


Figure 4.144: Short Knife Guard Hold-Down

5. Run the header at a low idle, and listen for noise caused by insufficient clearance. Adjust the header as necessary.

**IMPORTANT:**

An insufficient hold-down clearance will cause the knife and the guards to overheat.

6. Disengage the reel safety props. For instructions, refer to [Disengaging Reel Safety Props, page 40](#).

### Replacing Center Knife Guard – Double-Knife Headers

The offset guard at the center of a double-knife header (where the two knives overlap) requires a slightly different replacement procedure than a standard guard.

**⚠ DANGER**

To prevent bodily injury or death from the unexpected start-up of the machine, always stop the engine and remove the key from the ignition before making adjustments to the machine.

**⚠ DANGER**

Ensure that all bystanders have cleared the area.

**⚠ WARNING**

To prevent bodily injury from the fall of a raised reel, always engage the reel safety props before going under the raised reel for any reason.

**⚠ WARNING**

Wear heavy gloves when working around or handling knives.

1. Raise the reel fully.
2. Shut down the engine, and remove the key from the ignition.
3. Engage the reel safety props. For instructions, refer to [Engaging Reel Safety Props, page 39](#).
4. Remove two nuts and bolts (C) securing center knife guard (A) and hold-down (B) to the cutterbar.
5. Remove center knife guard (A), plastic wearplate, and hold-down (B).

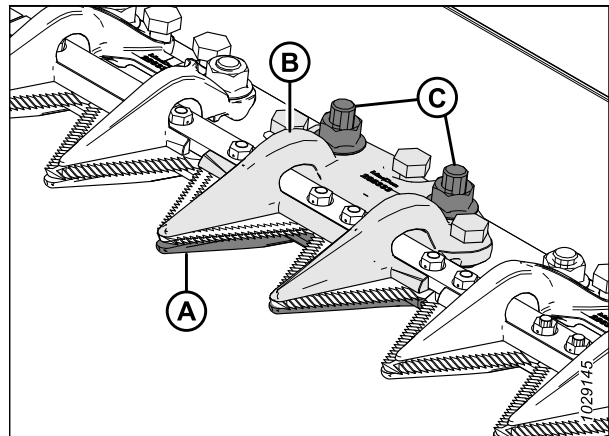


Figure 4.145: Center Knife Guard

## MAINTENANCE AND SERVICING

### IMPORTANT:

Ensure that the replacement center knife guard is the correct guard with offset cutting surfaces (A).

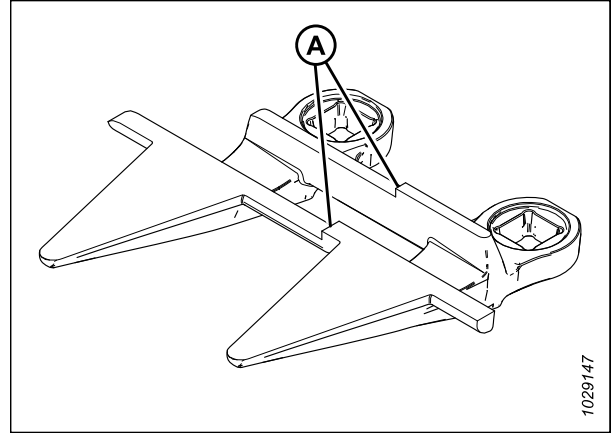


Figure 4.146: Center Knife Guard

6. Before installing the new center knife guard, ensure that overlap shim (A) is under the cutterbar, and that the thick end of the shim is positioned under the center knife guard.

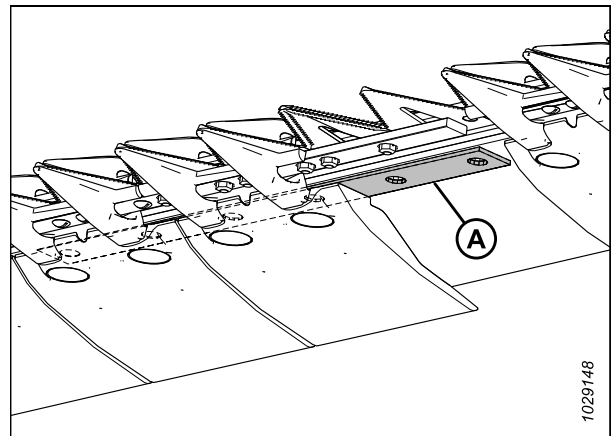


Figure 4.147: Cutterbar

7. Position plastic wearplate (A) and new center knife guard (B) under the cutterbar.

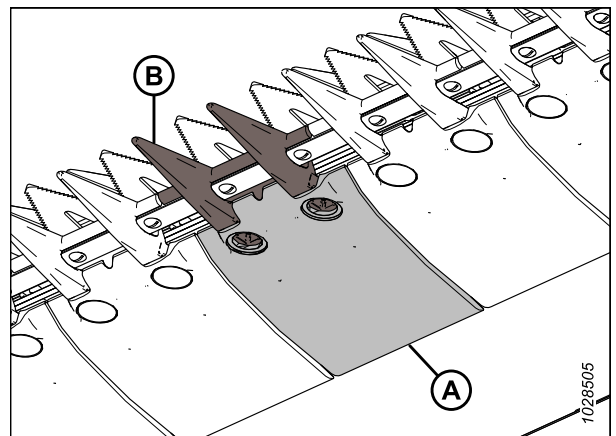


Figure 4.148: Center Knife Guard and Wearplate

## MAINTENANCE AND SERVICING

8. Thread three adjustment bolts (A) so that they protrude 4 mm (5/32 in.) from the bottom of center hold-down (B).
9. Position center hold-down (B) onto the cutterbar.

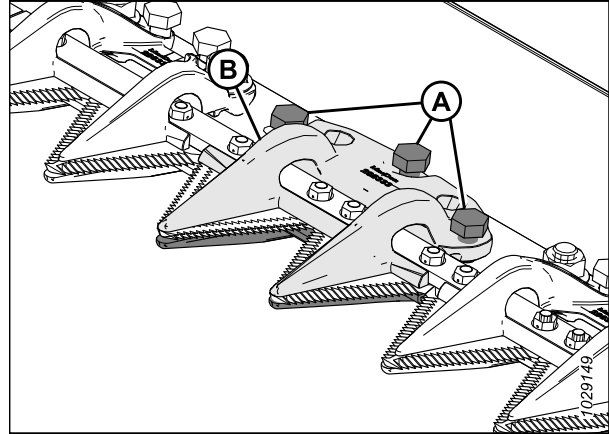


Figure 4.149: Center Knife Guard

10. Secure center hold-down (A) with two bolts and nuts (B), but do **NOT** tighten the nuts at this time.

### IMPORTANT:

Hold-down (A) must accommodate two overlapping knives at the center knife guard location. Install the proper replacement center knife guard at this location.

11. Adjust the hold-down until the clearance is acceptable.
  - For adjustment instructions, refer to [Adjusting Center Hold-Down – Short Knife Guards](#), page 663.
  - For clearance specifications, refer to [Checking Center Hold-Down on Double-Knife Headers – Short Knife Guards](#), page 662.

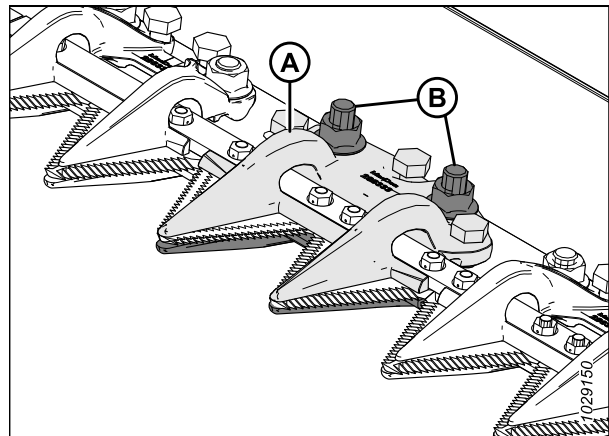


Figure 4.150: Center Knife Guard

12. Tighten nuts (B) to 85 Nm (63 lbf-ft).

### Checking Center Hold-Down on Double-Knife Headers – Short Knife Guards

The short center knife guard hold-down prevents the center knife sections on the cutterbar from lifting off of the guard while still allowing the knife to slide. Inspect the center hold-down to ensure that there is adequate clearance between the hold-down and the center knife sections.

### DANGER

To prevent bodily injury or death from the unexpected start-up of the machine, always stop the engine and remove the key from the ignition before making adjustments to the machine.

### DANGER

Ensure that all bystanders have cleared the area.

### WARNING

To prevent bodily injury from the fall of a raised reel, always engage the reel safety props before going under the raised reel for any reason.

### WARNING

Wear heavy gloves when working around or handling knives.

## MAINTENANCE AND SERVICING

1. Raise the reel fully.
2. Shut down the engine, and remove the key from the ignition.
3. Engage the reel safety props. For instructions, refer to *Engaging Reel Safety Props, page 39*.
4. Open the endshield. For instructions, refer to *Opening Header Endshields, page 41*.
5. Rotate the flywheel attached to the knife drive box to position the knife inboard until the knife section is under hold-down (A). Repeat this step to move the other knife.
6. Push down on the knife section with approximately 44 N (10 lbf) of force. Use a feeler gauge to measure the clearance between hold-down (A) and the knife section. Ensure that the clearance is as follows:
  - At tip (B) of hold-down: 0.1–0.5 mm (0.004–0.020 in.)
  - At rear (C) of hold-down: 0.1–1.0 mm (0.004–0.040 in.)
7. If adjustment is required, refer to *Adjusting Center Hold-Down – Short Knife Guards, page 663*.
8. Tighten nuts (D), recheck the clearance, and adjust if necessary.
9. Close the endshield. For instructions, refer to *Closing Header Endshields, page 42*.

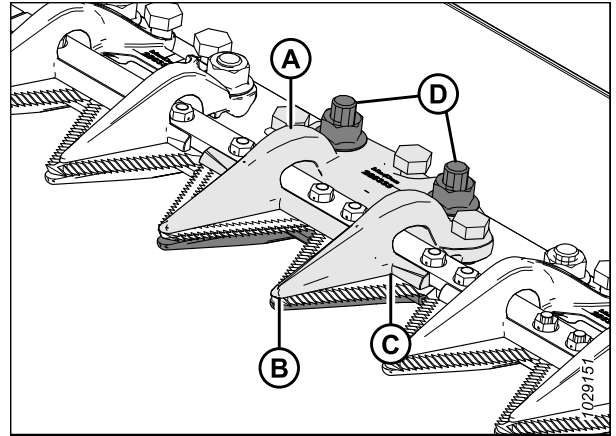


Figure 4.151: Center Knife Guard Hold-Down

### *Adjusting Center Hold-Down – Short Knife Guards*

If a short knife guard hold-down is binding the knife, adjust the hold-down.

#### **DANGER**

To prevent bodily injury or death from the unexpected start-up of the machine, always stop the engine and remove the key from the ignition before making adjustments to the machine.

#### **DANGER**

Ensure that all bystanders have cleared the area.

#### **WARNING**

To prevent bodily injury from the fall of a raised reel, always engage the reel safety props before going under the raised reel for any reason.

#### **WARNING**

Wear heavy gloves when working around or handling knives.

1. Raise the reel fully.
2. Shut down the engine, and remove the key from the ignition.
3. Engage the reel safety props. For instructions, refer to *Engaging Reel Safety Props, page 39*.

4. Loosen mounting hardware (B).
5. Adjust the hold-down clearance as follows:
  - To increase the clearance, rotate adjuster bolts (A) clockwise (tighten the bolts).
  - To decrease the clearance, rotate adjuster bolts (A) counterclockwise (loosen the bolts).
6. To adjust the clearance at the tip of the hold-down, turn adjustment bolt (C) as follows:
  - To increase the clearance, turn adjuster bolt (C) counterclockwise (loosen the bolts).
  - To decrease the clearance, turn adjuster bolt (C) clockwise (tighten the bolts).
7. Torque nuts (B) to 85 Nm (63 lbf-ft).
8. Run the engine at a low idle while listening for noise caused by insufficient clearance. Adjust the knives as necessary.

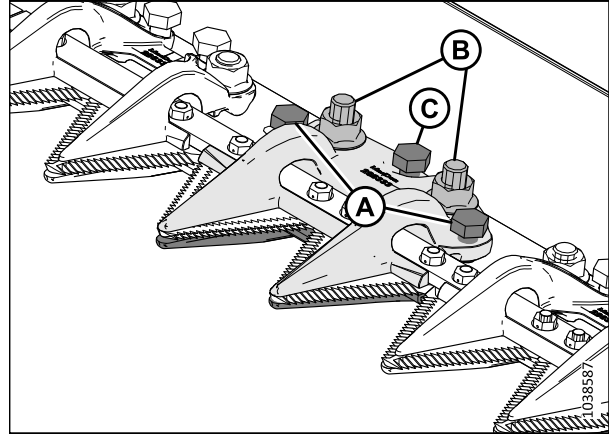


Figure 4.152: Center Hold-Down

**IMPORTANT:**

An insufficient hold-down clearance will cause the knife and the guards to overheat.

### 4.8.7 Knifehead Shield

The knifehead shield attaches to the endsheet and reduces the knifehead opening to prevent cut crop from accumulating in the knifehead cutout.

**IMPORTANT:**

Remove the shields when using the cutterbar on the ground in muddy conditions. The mud may pack into the cavity behind the shield, resulting in knife drive box failure.

#### *Installing Knifehead Shield*

The knifehead shield is primarily used in rice and fine grasses to keep the crop from getting caught in the delivery opening. The knifehead shield is not recommended in all conditions.

**! DANGER**

To prevent bodily injury or death from the unexpected start-up or fall of a raised machine, always stop the engine, remove the key, and engage the safety props before going under the header for any reason.

**! WARNING**

To prevent bodily injury from the fall of a raised reel, always engage the reel safety props before going under the raised reel for any reason.

**! DANGER**

Ensure that all bystanders have cleared the area.

**! WARNING**

Wear heavy gloves when working around or handling knives.



## MAINTENANCE AND SERVICING

### IMPORTANT:

If the shields are required in muddy conditions, check the cavity behind the shield frequently and remove any mud that packs behind the shield.

1. Raise the reel fully.
2. Lower the header fully.
3. Shut down the engine, and remove the key from the ignition.
4. Engage the reel safety props. For instructions, refer to *Engaging Reel Safety Props, page 39*.
5. Retrieve the knifehead shields from the manual storage case.
6. Place knifehead shield (A) against the endsheet as shown. Align the shield so that the cutout matches the profile of the knifehead and/or the hold-downs.
7. Align the mounting holes and secure the shield with two M10 x 30 hex head bolts, washers (B), and nuts.
8. Tighten bolts (B) just enough to hold knifehead shield (A) in place while allowing the shield to be as close to the knifehead as possible.
9. Manually rotate the knife drive box pulley to move the knife and check for interference between the knifehead and knifehead shield (A). Adjust the knifehead shield to eliminate any interference with the knife.
10. Torque bolts (B) to 11 Nm (8.11 lbf·ft [97 lbf·in]).

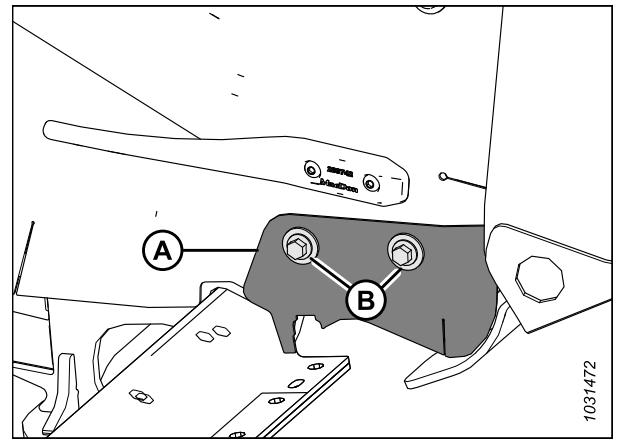


Figure 4.153: Knifehead Shield

## 4.9 Knife Drive System

The knife drive system transforms pumped hydraulic pressure into a mechanical motion that strokes a series of serrated knife blades at the front of the header to cut a variety of crops.

### 4.9.1 Knife Drive Box

The knife drive box is driven by a hydraulic motor and converts rotational motion into the reciprocating motion of the knife.

Single-knife headers have a knife drive box (A) and motor (B) on the left side of the header; double-knife headers have a knife drive box and motor at each end of the header.

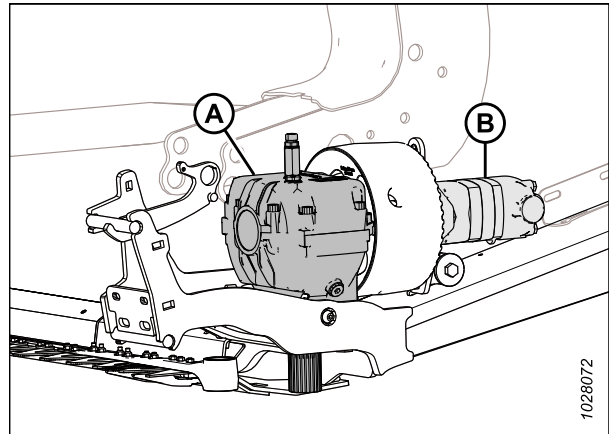


Figure 4.154: Left Knife Drive Box Shown – Right Similar

#### *Checking Oil Level in Knife Drive Box*

There must be a sufficient level of oil in each knife drive box for the knife drive to work correctly. You can inspect the oil level using the dipstick installed in each knife drive.

#### **⚠ DANGER**

To prevent bodily injury or death from the unexpected start-up of the machine, always stop the engine and remove the key from the ignition before making adjustments to the machine.

#### **⚠ DANGER**

Ensure that all bystanders have cleared the area.

1. Ensure that the header is level.
2. Lower the header fully.
3. Adjust the header angle so that the top of the knife drive box is level with the ground.
4. Shut down the engine, and remove the key from the ignition.
5. Open the endshield. For instructions, refer to [Opening Header Endshields, page 41](#).

## MAINTENANCE AND SERVICING

6. Remove oil level dipstick (A), wipe it, and then reinstall it. Tighten it until it is finger-tight.
7. Remove the dipstick again to check the oil level. The oil level must be within range (B), between the lines near the bottom of the dipstick.
8. Reinstall dipstick (A). Tighten the dipstick to 23 Nm (17 lbf-ft [204 lbf-in]).
9. If the header has two knife drives, repeat Step 5, page 666 to Step 8, page 667 to check the oil level for the other knife drive.

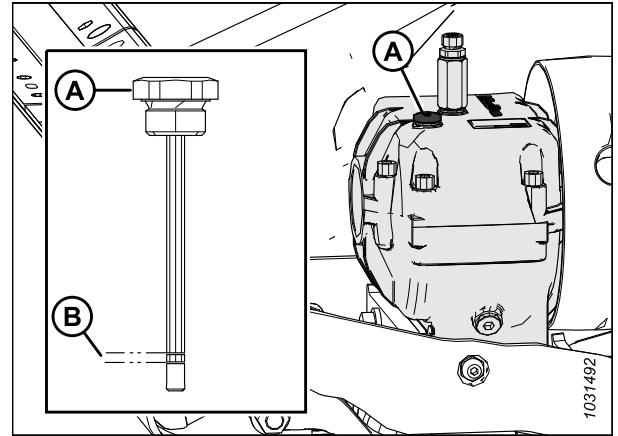


Figure 4.155: Knife Drive Box

### Checking Mounting Bolts

After the first 10 hours of operation, check the torque on the four knife drive box mounting bolts (A) and (B) and every 100 hours thereafter.

1. Ensure that all bolts are torqued to 343 Nm (253 lbf-ft). Torque side bolts (A) first, then bottom bolts (B).

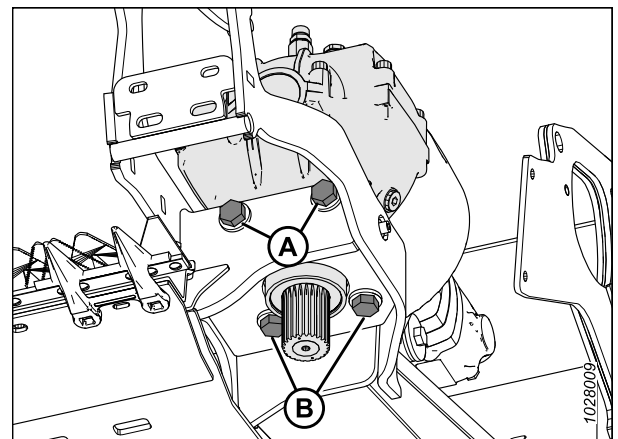


Figure 4.156: Knife Drive Box – View from Below

### Changing Oil in Knife Drive Box

After the first 50 hours of operation, change the knife drive box lubricant and every 1000 hours (or 3 years) thereafter.

#### DANGER

To prevent bodily injury or death from the unexpected start-up of the machine, always stop the engine and remove the key from the ignition before making adjustments to the machine.

#### DANGER

Ensure that all bystanders have cleared the area.

1. Raise the header fully.
2. Shut down the engine, and remove the key from the ignition.
3. Open the endshield. For instructions, refer to *Opening Header Endshields*, page 41.

## MAINTENANCE AND SERVICING

4. Under the knife drive box, place a container large enough to hold approximately 1.5 L (0.4 US gal) of oil.
5. Remove dipstick (A) and drain plug (C).
6. Allow the oil to drain from the knife drive box and into the container below it.
7. Reinstall drain plug (C).
8. Add 1.5 L (0.4 US gal) of oil to the knife drive box. Refer to the inside back cover for recommended fluids and lubricants.

**NOTE:**

Check the oil level with the top of the knife drive box horizontal and with oil level dipstick (A) screwed in.

9. Check that the oil level is within range (B).
10. Close the endshield. For instructions, refer to [Closing Header Endshields, page 42](#).

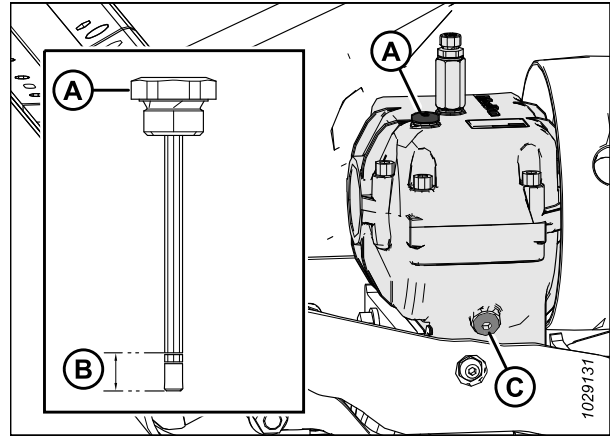


Figure 4.157: Knife Drive Box

## 4.10 Feed Deck

The feed deck is located on the FM200 Float Module. It uses a feed draper which conveys the cut crop to the feed auger.

### 4.10.1 Replacing Feed Draper

The feed draper on the float module delivers harvested crop into the combine's feeder house. If the feed draper is torn, cracked, or missing slats, replace it.

#### DANGER

To prevent bodily injury or death from the unexpected start-up or fall of a raised machine, always stop the engine and remove the key before leaving the operator's seat, and always engage the safety props before going under the machine for any reason.

#### DANGER

Ensure that all bystanders have cleared the area.

#### WARNING

To prevent bodily injury from the fall of a raised reel, always engage the reel safety props before going under the raised reel for any reason.

1. On the underside of the feed deck, rotate latch (A) to unlock handle (B).
2. Repeat the previous step on the other side of the feed deck.

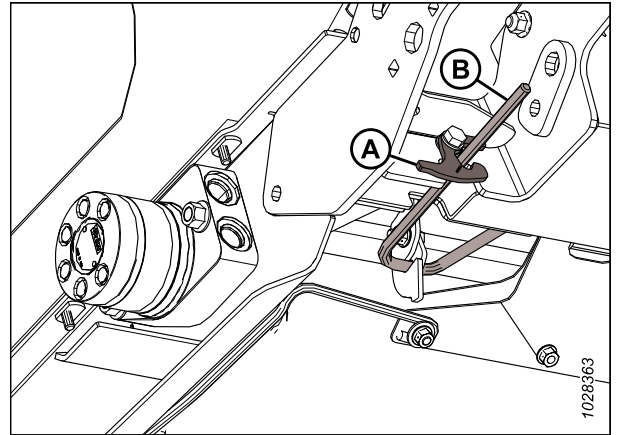


Figure 4.158: Underside of Feed Deck

3. Hold pan (A) and rotate handle (B) downward to release the pan.

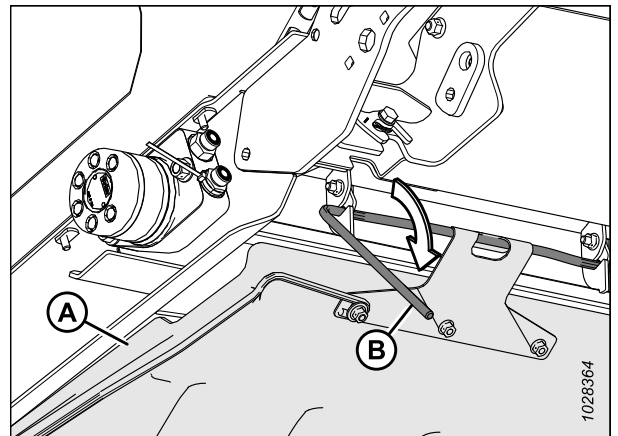


Figure 4.159: Underside of Feed Deck

## MAINTENANCE AND SERVICING

- Lower feed deck pan (A).

**NOTE:**

Lowering the feed deck pan improves access to the hardware securing the feed draper.

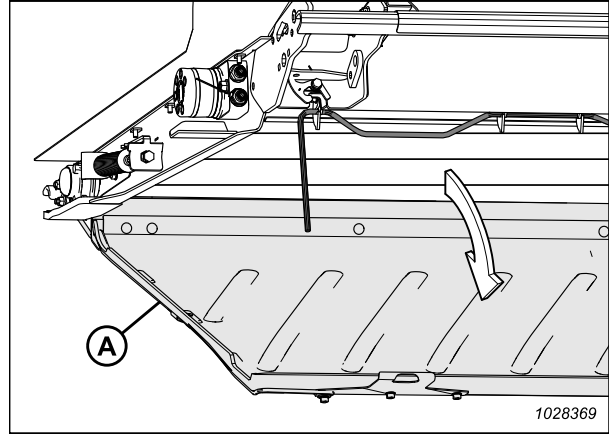


Figure 4.160: Feed Deck Pan

- Start the engine.
- Raise the header fully.
- Raise the reel fully.
- Shut down the engine, and remove the key from the ignition.
- Engage the header safety props. For instructions, refer to the combine operator's manual.
- Engage the reel safety props. For instructions, refer to *Engaging Reel Safety Props, page 39*.
- Remove five countersunk screws (A) and retainer (B).
- Remove one button head screw and washer (C).
- Flip mid-filler (D) over.
- Repeat Steps 11, page 670 to 13, page 670 on the other side of the feed deck.

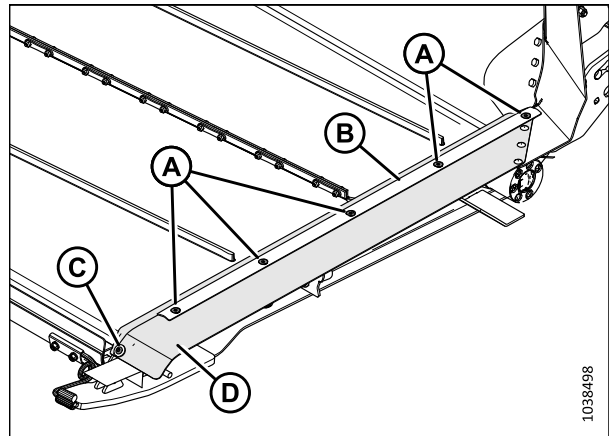


Figure 4.161: Feed Draper Seal

## MAINTENANCE AND SERVICING

15. Locate the feed draper tensioner. Loosen jam nut (A). Turn bolt (B) counterclockwise to relieve the tension on the draper.

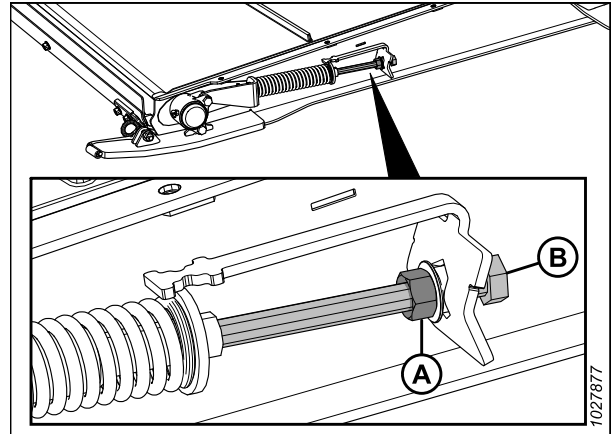


Figure 4.162: Feed Draper Tensioner

16. On the left side of the deck, remove hardware (A) from idler roller casting (B).

**NOTE:**

Note whether the idler casting drops down or moves upward when the hardware is removed. It will be easier to start reinstalling the casting hardware on the side where the idler casting drops down.

17. Repeat the previous step on the right side of the deck.
18. Move the idler roller back inside of the cutout in the frame.

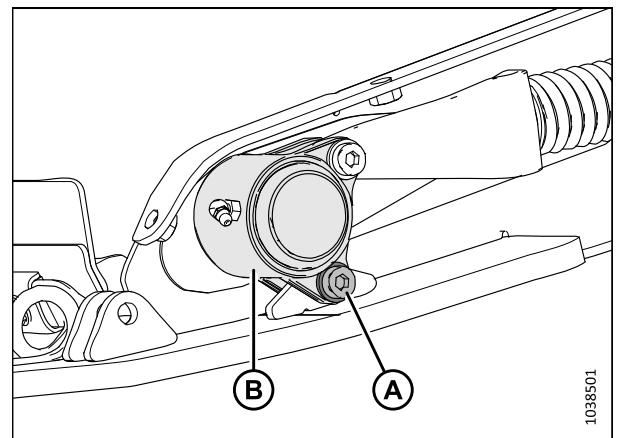


Figure 4.163: Idler Roller Bearing Casting

19. Remove nuts and screws (A). Remove draper connector straps (B).
20. Pull the draper from the deck.

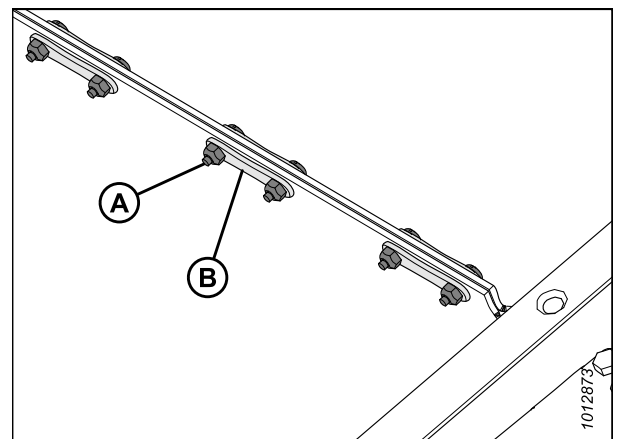


Figure 4.164: Draper Connector



## MAINTENANCE AND SERVICING

21. Install the new draper over drive roller (A). Ensure that the draper guides fit into drive roller grooves (B).
22. Pull the draper along the bottom of the feed deck and over idler roller (C).

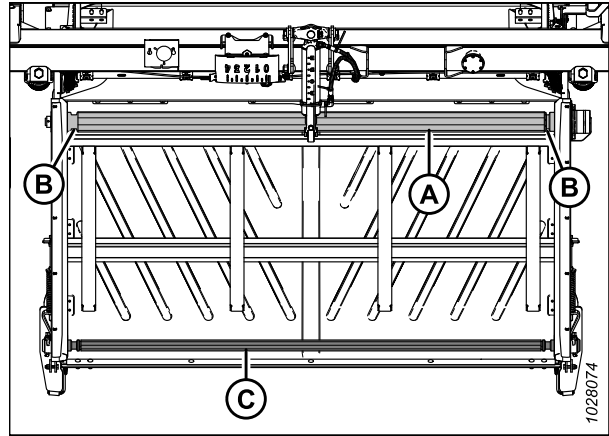


Figure 4.165: Float Module Feed Draper

23. Connect the draper joint with connector straps (B). Secure the straps with nuts and screws (A).

### IMPORTANT:

Ensure that the screw heads face the rear of the deck. Tighten the screws **only** until the ends of the screws are flush with the nuts.

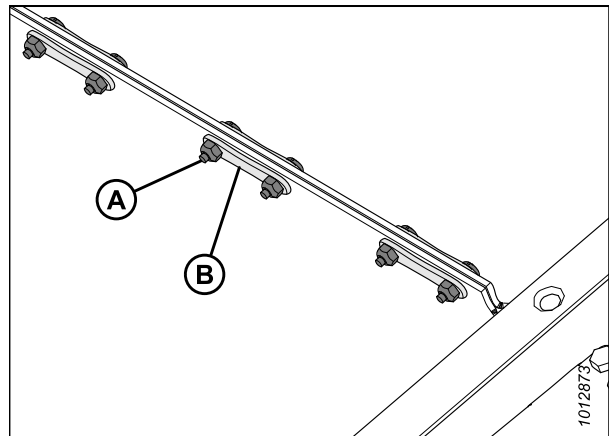


Figure 4.166: Draper Connector Straps

24. Move the idler roller back to the operating position.
25. Apply medium-strength threadlocker (Loctite® 243 or equivalent) to the threads of hardware (A).
26. On the side of the feed deck where the casting dropped when the hardware was removed, reinstall hardware (A) to secure idler roller casting (B) to the frame.
27. Repeat the previous two steps on the opposite side of the feed deck.
28. Tighten bolt (A) to 12 Nm (8.85 lbf-ft [106 lbf-in]).

### IMPORTANT:

Do **NOT** fully tighten bolt (A).

29. Adjust the draper tension. For instructions, refer to [4.10.2 Checking and Adjusting Feed Draper Tension](#), page 674.

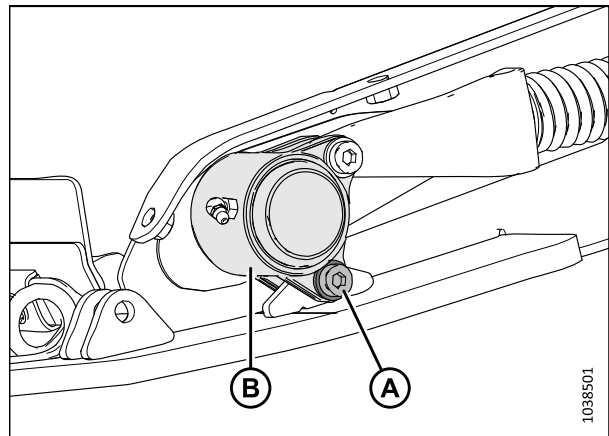


Figure 4.167: Idler Roller Bearing Casting

## MAINTENANCE AND SERVICING

30. Position mid-filler (D) as shown. Reinstall retainer (B).
31. Secure the retainer and the mid-filler with one button head screw and washer (C) and five countersunk screws (A).
32. Repeat the previous two steps on the opposite side of the feed deck.

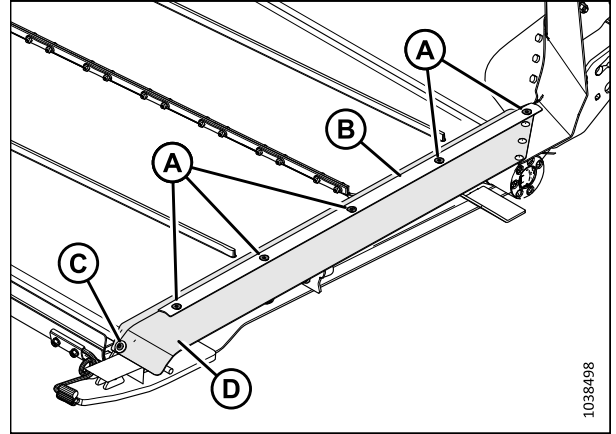


Figure 4.168: Feed Draper Seal

33. Raise feed deck pan (A).

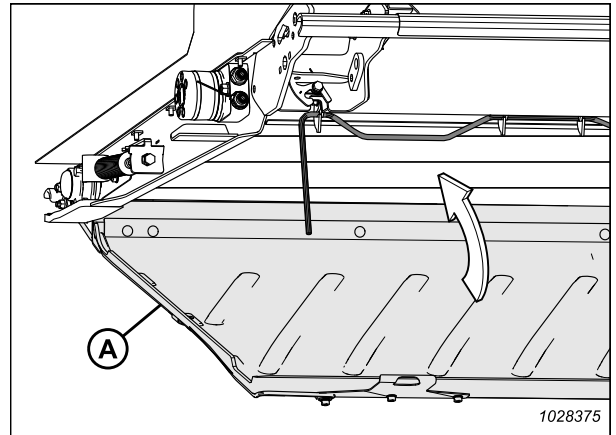


Figure 4.169: Feed Deck Pan

34. Engage lock handle (A) in three feed deck pan hooks (B).

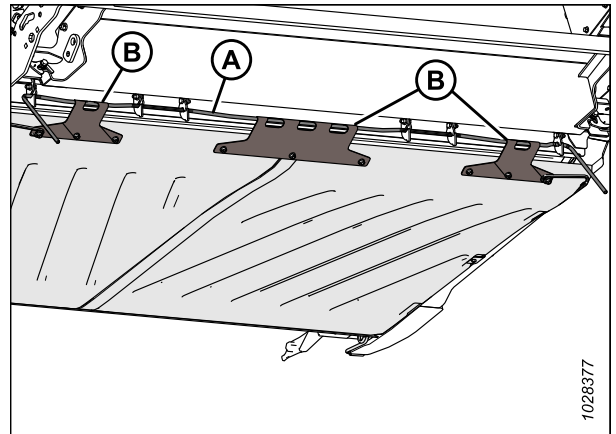


Figure 4.170: Underside of Feed Deck Pan

35. Rotate handles (A) upward to bring the feed deck pan into the locked position.

**NOTE:**

Ensure that all three deck pan hooks (B) are secured on the lock handle.

36. Hold the feed deck pan in place and rotate latch (C) to lock handle (A).

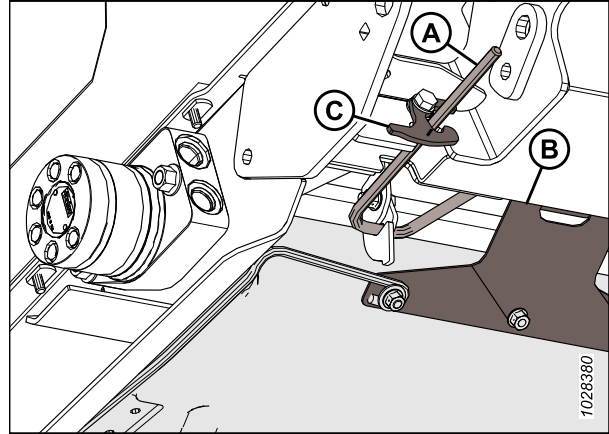


Figure 4.171: Underside of Feed Deck Pan

### 4.10.2 Checking and Adjusting Feed Draper Tension

In order for the draper to operate correctly, it must be tensioned properly. Inspect the tension on the draper and if necessary, adjust it.

**⚠ DANGER**

To prevent bodily injury or death from the unexpected start-up or fall of a raised machine, always stop the engine and remove the key before leaving the operator's seat, and always engage the safety props before going under the machine for any reason.

**⚠ DANGER**

Ensure that all bystanders have cleared the area.

**NOTE:**

The illustrations in this procedure show the left side of the header; the right side of the header is similar.

1. Raise the header fully.
2. Shut down the engine, and remove the key from the ignition.
3. Engage the header safety props. For instructions, refer to the combine operator's manual.

***Checking the feed draper tension***

4. Ensure that the draper guide (the rubber track on the underside of the draper) is properly engaged in the groove on the drive roller and that the idler roller is between the guides.

## MAINTENANCE AND SERVICING

5. Check the position of spring retainer disc (A). If the feed draper tracks properly and the spring retainers on both sides of the draper are correctly positioned, then no adjustment is necessary.

### NOTE:

The starting position of spring retainer disc (A) is centered within the U shape on indicator (B); however, the position of disc (A) will vary after the draper tracking is adjusted.

6. If adjustment is necessary, proceed to Step 7, page 675.

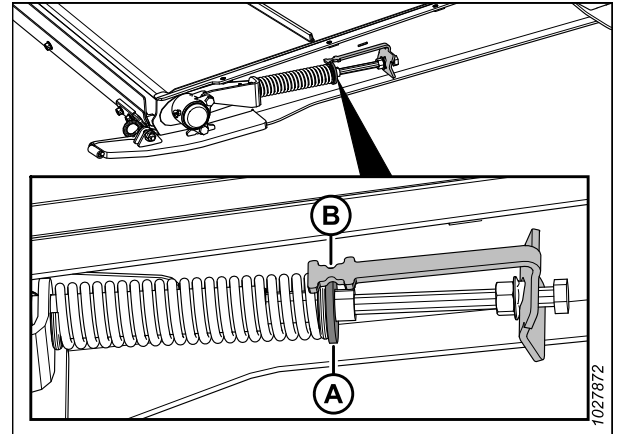


Figure 4.172: Feed Draper Tensioner

### Adjusting the feed draper tension

7. Adjust the draper tension by loosening jam nut (A) and turning bolt (B) clockwise to increase the tension on the draper (or counterclockwise to decrease the tension on the draper). Retainer disc (C) should be in the middle of indicator (D).

### IMPORTANT:

For small tension adjustments, only one side of the draper needs to be adjusted. To prevent uneven draper tracking for larger tension adjustments, both sides of the draper will need to be adjusted.

8. If the draper is not tracking properly, adjust retainer disc (C) so that it is **NOT** in the middle of indicator (D), but within the following range:
  - When loosened to 3 mm (1/8 in.), retainer disc (C) will move toward the front of the deck from center of indicator (D).
  - When tightened to 6 mm (1/4 in.), retainer disc (C) will move toward the back of the deck from the center of indicator (D).
9. Tighten jam nut (A). Ensure that flange nut (E) is tight against the indicator bracket.

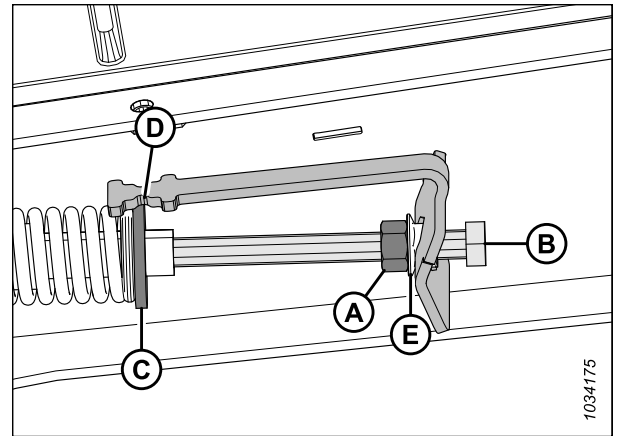


Figure 4.173: Feed Draper Tensioner – Left Side

### 4.10.3 Feed Draper Drive Roller

The feed draper drive roller is hydraulically driven to rotate the feed draper and convey the crop toward the feed auger.

#### *Removing Feed Draper Drive Roller*

The feed draper drive roller needs to be removed when repairing or replacing it.

#### DANGER

To prevent bodily injury or death from the unexpected start-up or fall of a raised machine, always stop the engine and remove the key before leaving the operator's seat, and always engage the safety props before going under the machine for any reason.

#### WARNING

To prevent bodily injury from the fall of a raised reel, always engage the reel safety props before going under the raised reel for any reason.

#### DANGER

Ensure that all bystanders have cleared the area.

1. Raise the reel fully.
2. Raise the header fully.
3. Shut down the engine, and remove the key from the ignition.
4. Engage the reel safety props. For instructions, refer to *Engaging Reel Safety Props, page 39*.
5. Engage the header safety props. For instructions, refer to the combine operator's manual.
6. Locate the feed draper tensioner. Loosen jam nut (A). Turn bolt (B) counterclockwise to relieve the tension on the draper.

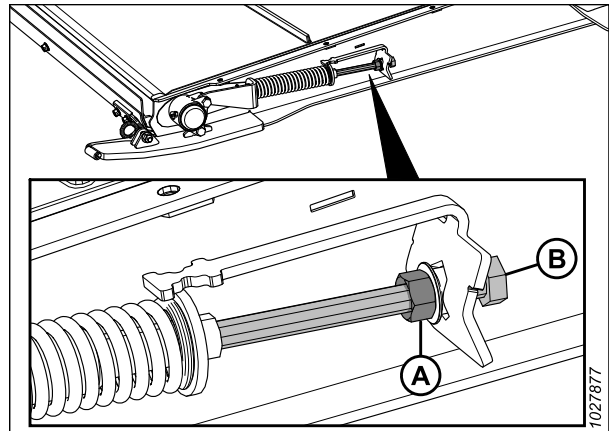


Figure 4.174: Feed Draper Tensioner

## MAINTENANCE AND SERVICING

7. Remove nuts and screws (A). Remove draper connector straps (B).
8. Lift the sides of the draper to expose the rollers.

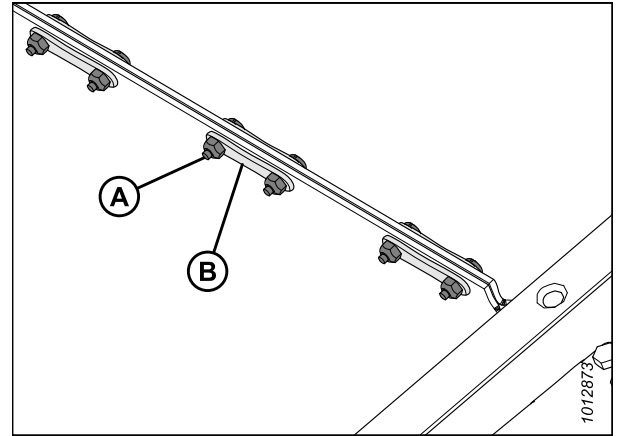


Figure 4.175: Draper Connector

9. On the right side of the deck, remove two nuts (A) and bolts from drive roller bearing housing (B).

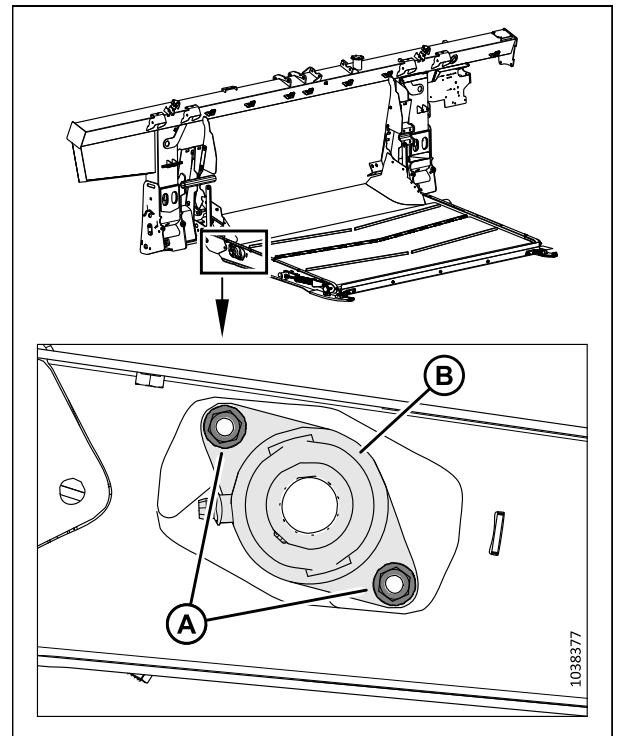


Figure 4.176: Drive Roller Bearing

## MAINTENANCE AND SERVICING

- Slide the drive roller with bearing assembly (A) to the right until the left end comes off of the motor spline.
- Remove both covers (B).

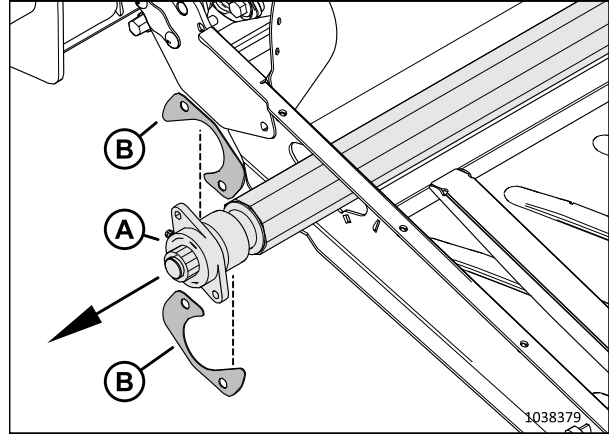


Figure 4.177: Drive Roller

- Lift the left end out of the frame.
- Slide assembly (A) to the left, guiding bearing housing (B) through frame opening (C).
- Remove roller (A).

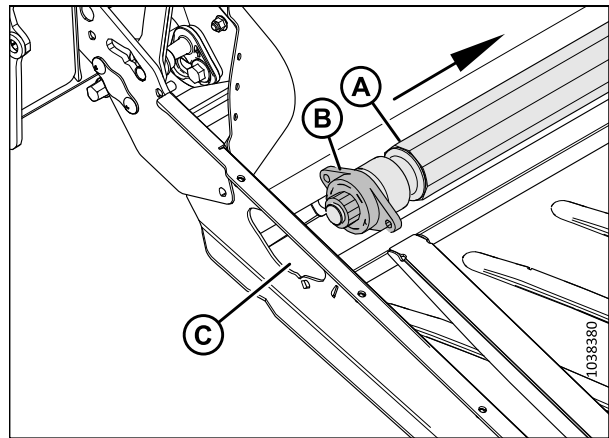


Figure 4.178: Drive Roller

### *Installing Feed Draper Drive Roller*

The feed draper drive roller needs to be installed after it has been repaired or replaced.

- Apply grease to the motor spline.
- Guide bearing end (A) of the drive roller through frame opening (B).

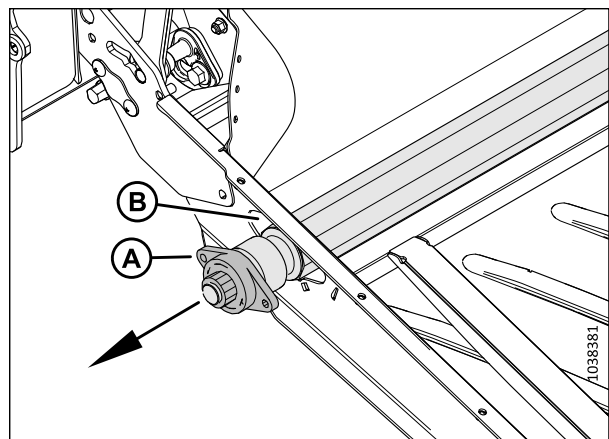


Figure 4.179: Drive Roller – Bearing End



## MAINTENANCE AND SERVICING

- Slide the left end of drive roller (A) onto spline of motor (B).

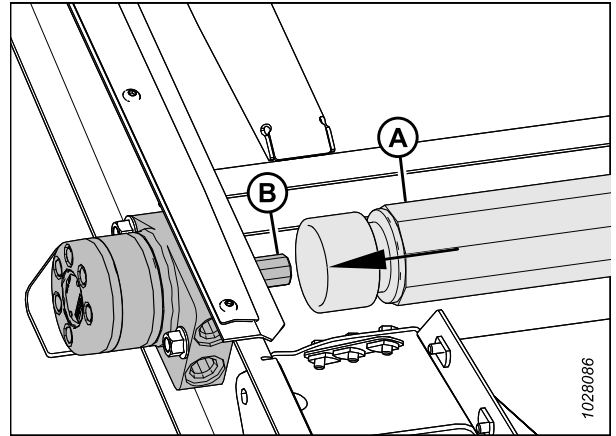


Figure 4.180: Feed Draper Motor

- Install two bolts (A) into the feed deck.
- Install both covers (B) onto the two bolts.  
**IMPORTANT:**  
Position the covers in the order shown.
- Secure the drive roller bearing housing using two nuts (C).
- Install the feed deck draper. For instructions, refer to [4.10.1 Replacing Feed Draper, page 669](#).
- Tension the feed draper. For instructions, refer to [4.10.2 Checking and Adjusting Feed Draper Tension, page 674](#).

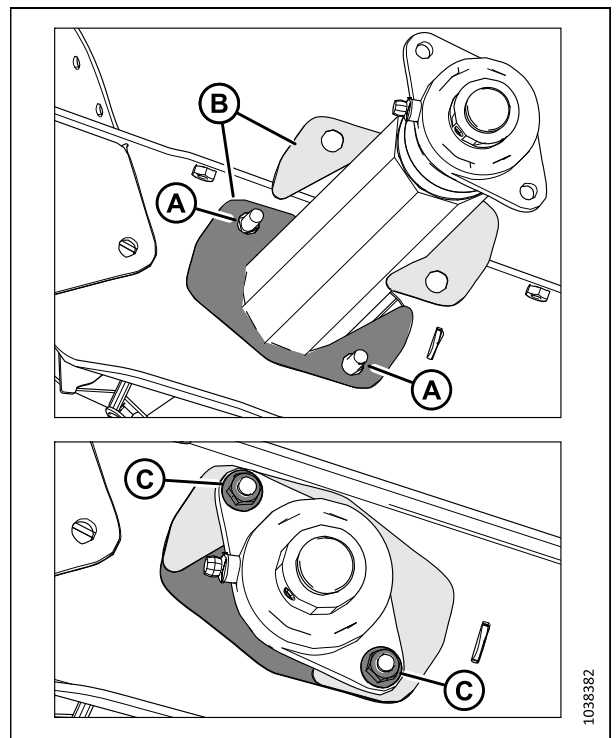


Figure 4.181: Drive Roller – Bearing End

### Removing Feed Draper Drive Roller Bearing

The feed draper drive roller bearing helps the roller turn. The bearing needs to be removed when replacing it.

### DANGER

To prevent bodily injury or death from the unexpected start-up or fall of a raised machine, always stop the engine and remove the key before leaving the operator's seat, and always engage the safety props before going under the machine for any reason.

**WARNING**

To prevent bodily injury from the fall of a raised reel, always engage the reel safety props before going under the raised reel for any reason.

1. Raise the reel fully.
2. Raise the header fully.
3. Shut down the engine, and remove the key from the ignition.
4. Engage the reel safety props. For instructions, refer to *Engaging Reel Safety Props, page 39*.
5. Engage the header safety props. For instructions, refer to the combine operator's manual.
6. Locate the feed draper tensioner. Loosen jam nut (A). Turn bolt (B) counterclockwise to relieve the tension on the draper.

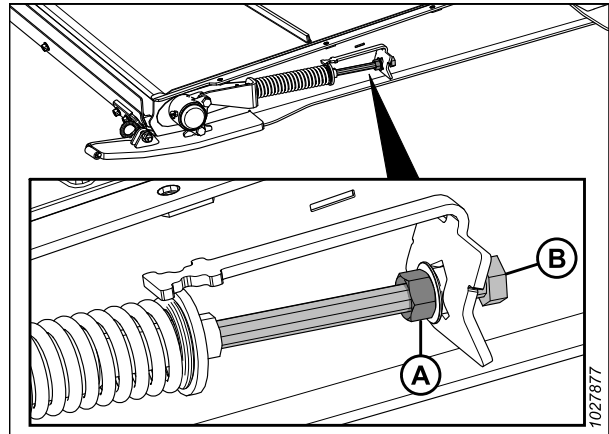


Figure 4.182: Feed Draper Tensioner

7. Loosen set screw (A) on bearing lock (B).
8. Using a hammer and punch, tap bearing lock (B) in the direction opposite of the auger's rotation to release the lock.

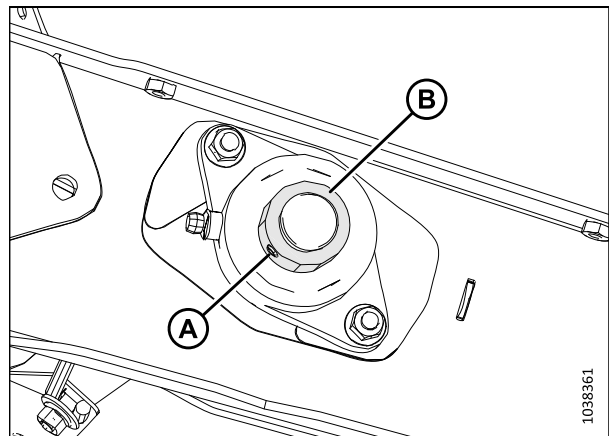


Figure 4.183: Feed Draper Drive Roller Bearing

## MAINTENANCE AND SERVICING

9. Remove two nuts (A).

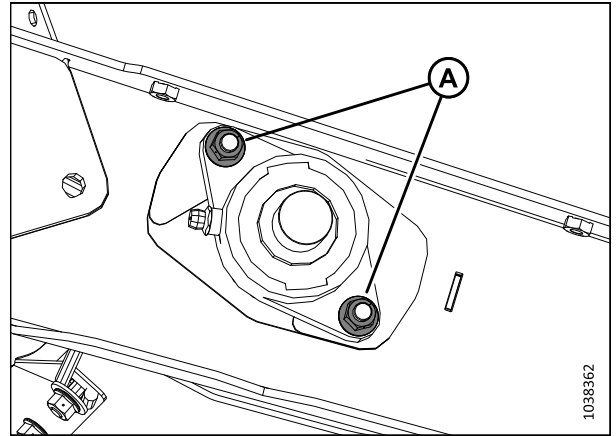


Figure 4.184: Feed Draper Drive Roller Bearing

10. Remove bearing housing (A).

**NOTE:**

If the bearing is seized on the shaft, it may be easier to remove the drive roller assembly. For instructions, refer to [Removing Feed Draper Drive Roller, page 676](#).

11. Inspect both covers (B) for damage. If they are damaged, replace them with the parts in kit MD #347553.

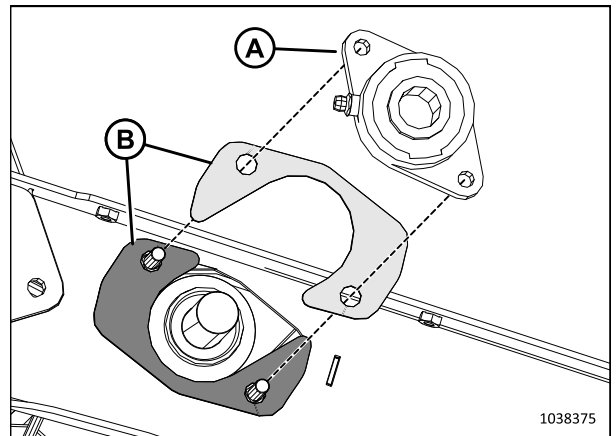


Figure 4.185: Feed Draper Drive Roller Bearing

### Installing Feed Draper Drive Roller Bearing

The bearing is held in place with bolts and a lock collar.

1. Install two bolts (A) into the feed deck.
  2. Install both covers (B) onto the two bolts.
- IMPORTANT:**  
Position the covers in the order shown.
3. Install drive roller bearing housing (C) onto the shaft.
  4. Secure the housing using two nuts (D).
  5. Install bearing lock collar (E) onto the shaft.
  6. Using a hammer and punch, tap the bearing lock in the direction of the auger's rotation to lock it.
  7. Tighten bearing lock set screw (F).
  8. Tension the feed draper. For instructions, refer to [4.10.2 Checking and Adjusting Feed Draper Tension](#), page 674.

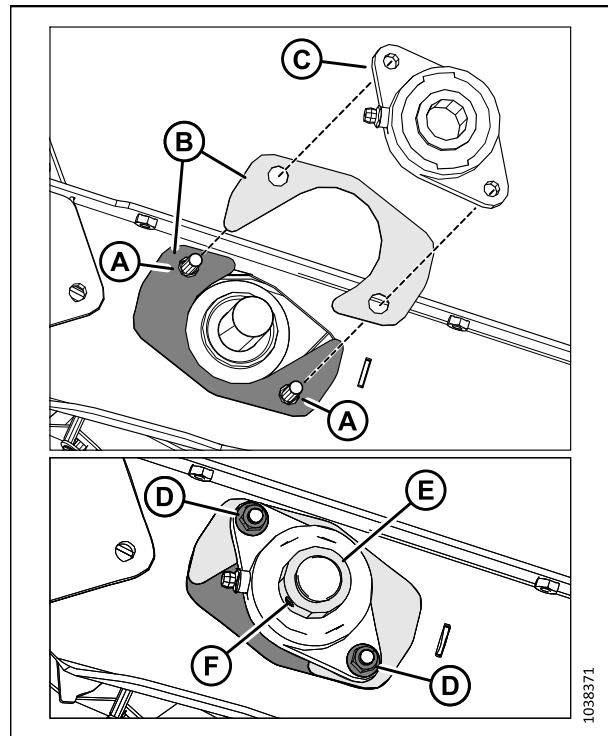


Figure 4.186: Feed Draper Drive Roller Bearing

### 4.10.4 Feed Draper Idler Roller

The feed draper idler roller is driven by the friction of the feed draper being turned by the drive roller. Like the drive roller, the idler roller helps the feed draper convey the crop to the auger.

#### Removing Feed Draper Idler Roller

The feed draper idler roller needs to be removed when it is being repaired or replaced.

#### DANGER

To prevent bodily injury or death from the unexpected start-up or fall of a raised machine, always stop the engine and remove the key before leaving the operator's seat, and always engage the safety props before going under the machine for any reason.

1. Raise the reel fully.
2. Raise the header fully.
3. Shut down the engine, and remove the key from the ignition.
4. Engage the reel safety props. For instructions, refer to [Engaging Reel Safety Props](#), page 39.
5. Engage the header safety props. For instructions, refer to the combine operator's manual.

## MAINTENANCE AND SERVICING

6. Locate the feed draper tensioner. Loosen jam nut (A). Turn bolt (B) counterclockwise to relieve the tension on the draper.

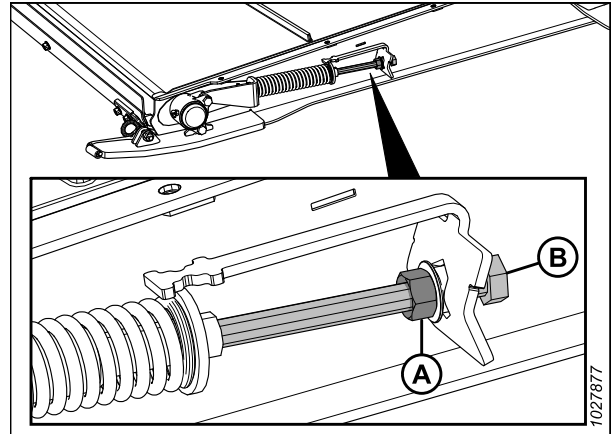


Figure 4.187: Feed Draper Tensioner

7. Remove nuts and screws (A). Remove draper connector straps (B).
8. Separate the draper.
9. Lower the front of the feed deck.

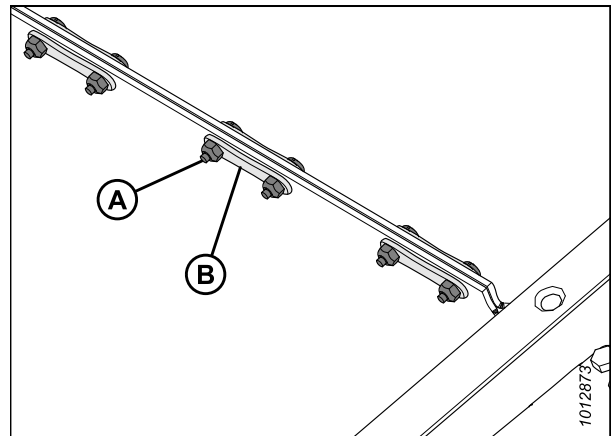


Figure 4.188: Draper Connector

10. Remove dust cap (A) and nut (B) from bearing housing (C).

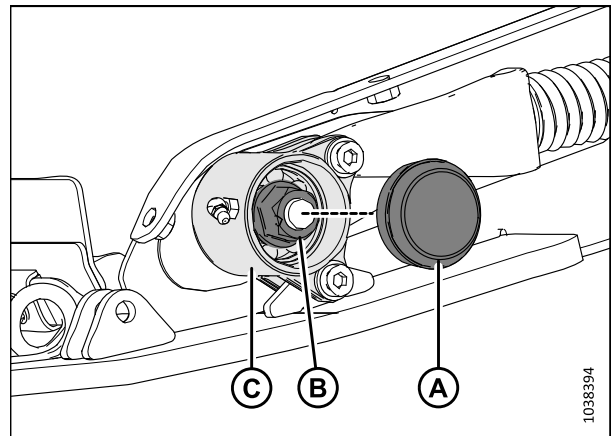


Figure 4.189: Idler Roller Bearing Housing

## MAINTENANCE AND SERVICING

11. Remove the hardware that secures the bearing housing to the deck skid and the tensioner from locations (A).
12. Remove bearing housing (B) from the idler roller.
13. Repeat Step 10, page 683 to Step 12, page 684 on the opposite side of the feed deck.

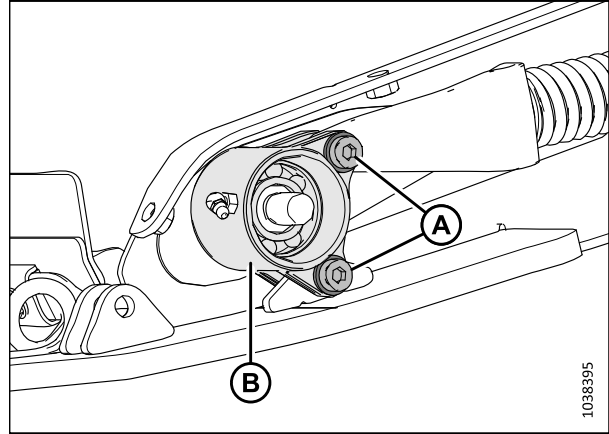


Figure 4.190: Idler Roller Bearing Housing

14. On one side of the deck frame, remove nut (A) and cover (B).

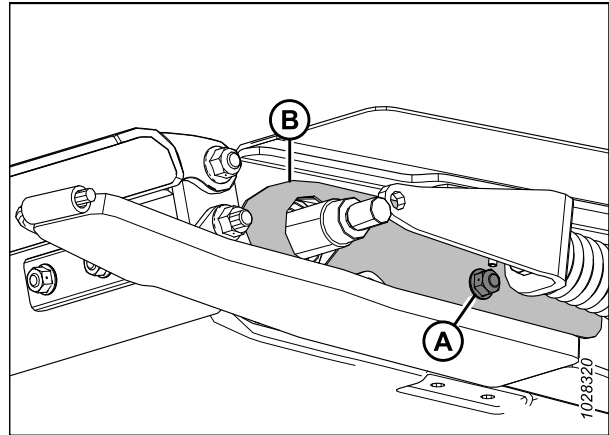


Figure 4.191: Idler Roller Cover

15. Slide idler roller (A) out through the other side of the deck frame.

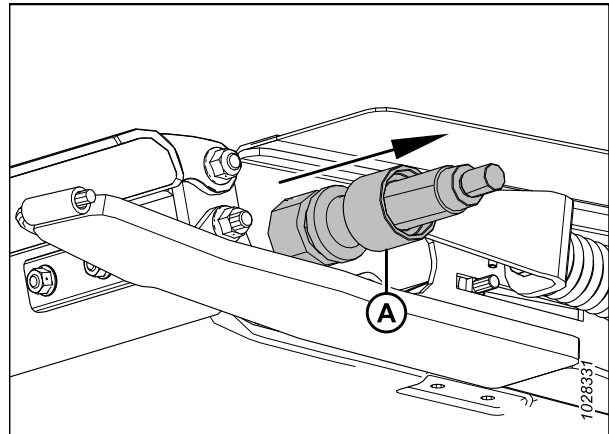


Figure 4.192: Idler Roller

*Installing Feed Draper Idler Roller*

The feed draper idler roller needs to be installed after it has been repaired or replaced.

1. Slide cover (A) over one end of the idler roller.
2. Brush idler roller shaft (B) with oil.
3. Carefully rotate bearing assembly (C) onto the shaft by hand to prevent damage to the seal.

**IMPORTANT:**

Ensure that the bearing assembly is square to the shaft to prevent damage to the seal during installation.

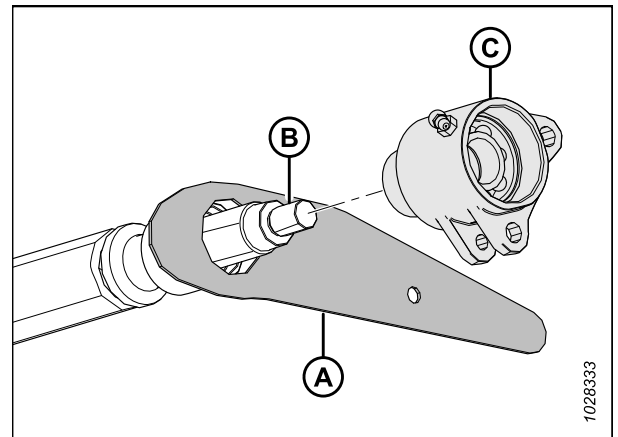


Figure 4.193: Idler Roller

4. After the bearing and both of the seals are seated around the shaft, install nut (A).
5. Torque the nut to 81 Nm (60 lbf-ft).

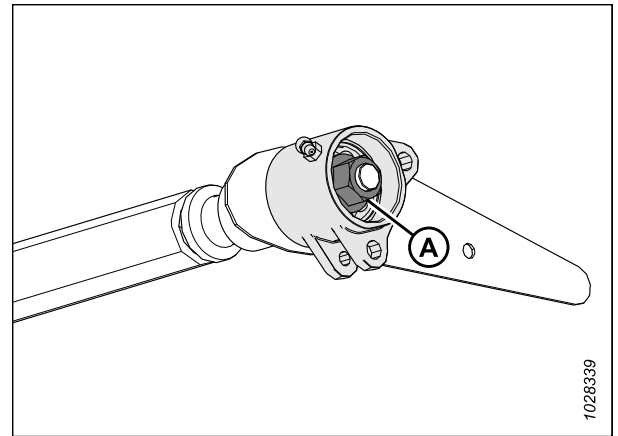


Figure 4.194: Left Idler Roller Bearing

6. Slide idler roller (A) through the cutout in the deck frame.

**NOTE:**

The right end of the idler roller should protrude from the right deck frame.

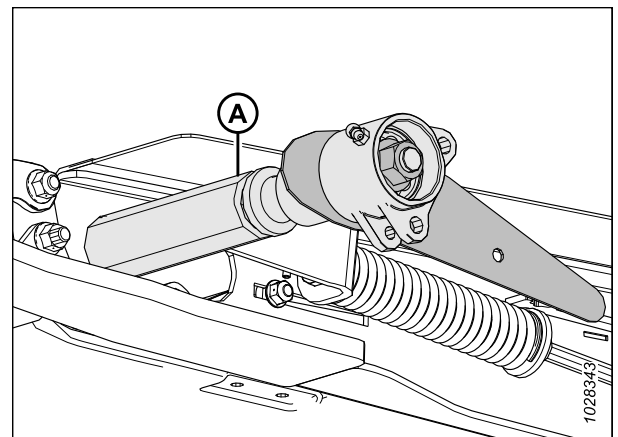


Figure 4.195: Feed Deck – Left Side

## MAINTENANCE AND SERVICING

7. Install the bolt from inside of the feed deck to secure idler cover (A).
8. Install nut (B). Do **NOT** overtighten the nut. The nut should hold the idler cover in place and move with the idler roller.

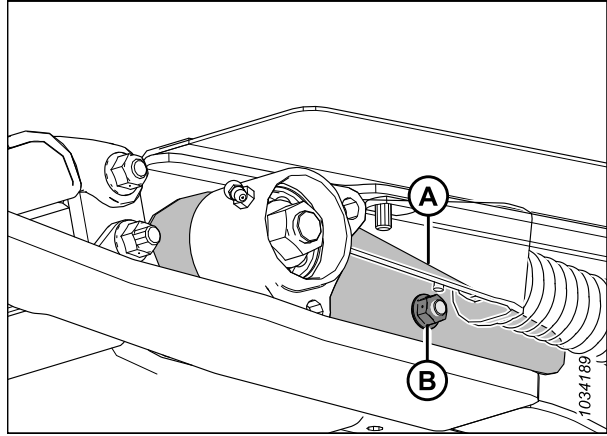


Figure 4.196: Idler Cover – Left Side

9. On the right side of the deck frame, brush the opposite end of the idler roller shaft (A) with oil.
10. Carefully rotate bearing assembly (B) onto shaft (A) by hand to prevent damage to the seal.

### IMPORTANT:

Ensure that the bearing assembly is square to the shaft to prevent damage to the seal during installation.

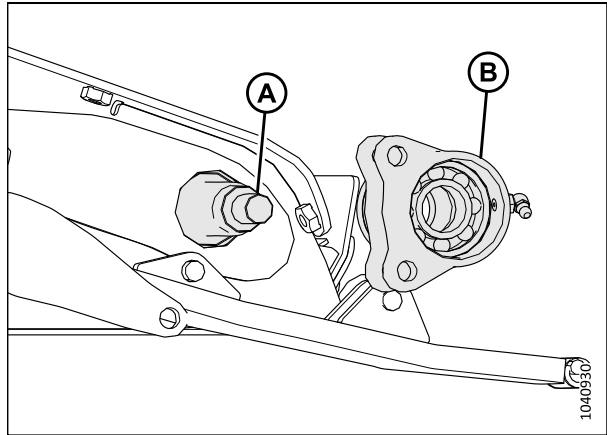


Figure 4.197: Feed Deck – Right Side

11. After the bearing and both of the seals are seated around the right side of the shaft, install nut (A).
12. Torque the nut to 81 Nm (60 lbf-ft).

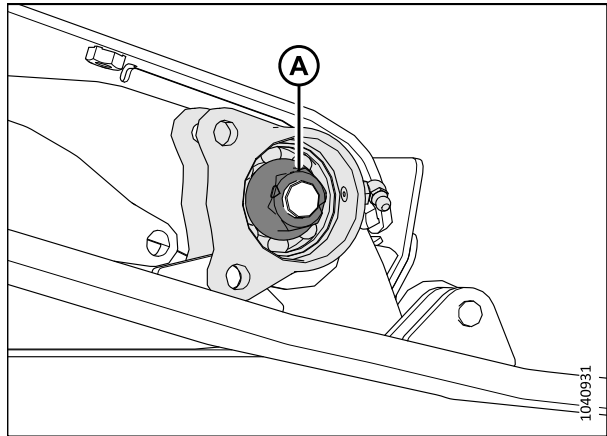


Figure 4.198: Feed Deck – Right Side



## MAINTENANCE AND SERVICING

13. Rotate idler roller housing (A) until the holes in the lower tabs align with the hole in welded tab (B).
14. Apply medium-strength threadlocker (Loctite® 243 or equivalent) to the threads of the socket head bolt, then secure the roller housing to the welded tab with the bolt, the washer, and the nut at location (C).
15. Align the hole in cast support (D) with the holes in the upper tab on idler roller housing (A).
16. Apply medium-strength threadlocker (Loctite® 243 or equivalent) to the threads of the socket head bolt, then secure the cast support to the roller housing with the bolt, the washer, and the nut at location (E).
17. Tighten bolts (C) and (E) to 12 Nm (8.85 lbf-ft [106 lbf-in]).

### IMPORTANT:

Do **NOT** overtighten bolts (C) and (E).

18. Lubricate the bearing cavity with grease, then install dust cap (A).
19. Ensure that the grease fitting is working. Grease the feed draper idler roller bearing until grease comes out of the seal. Wipe any excess grease from the area after greasing.
20. Repeat Step [13, page 687](#) to Step [19, page 687](#) on the right side of the feed draper idler roller.

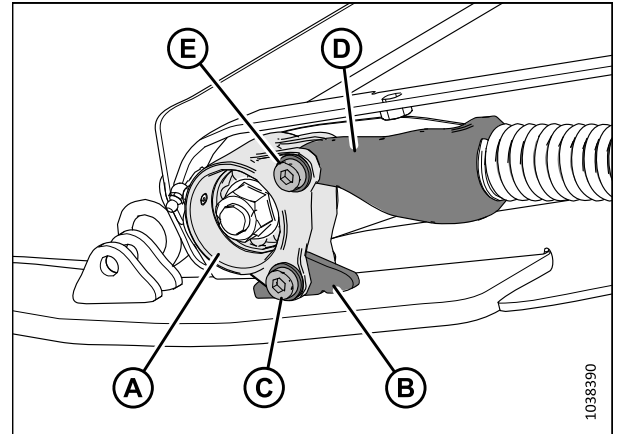


Figure 4.199: Left Idler Roller Bearing

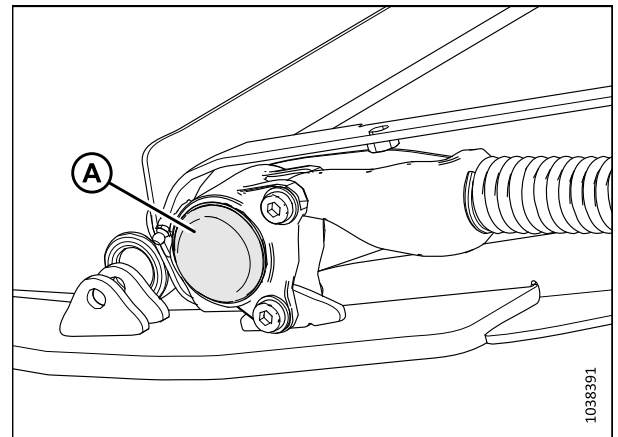


Figure 4.200: Feed Deck – Left Side

21. Close the feed draper and secure it with screws (A), connector straps (B), and nuts.
22. Tension the feed draper. For instructions, refer to [4.10.2 Checking and Adjusting Feed Draper Tension, page 674](#).

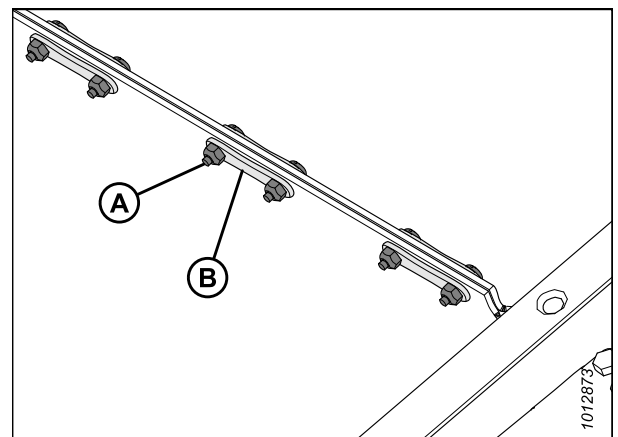


Figure 4.201: Draper Connector

### Replacing Feed Draper Idler Roller Bearing

The feed draper idler roller bearing helps the roller turn. The bearing needs to be removed when replacing it.

**NOTE:**

The procedure is the same for both sides of the feed draper idler roller. The left side of the roller is shown in the illustrations below.

**⚠ DANGER**

To prevent bodily injury or death from the unexpected start-up or fall of a raised machine, always stop the engine and remove the key before leaving the operator's seat, and always engage the safety props before going under the machine for any reason.

**⚠ WARNING**

To prevent bodily injury from the fall of a raised reel, always engage the reel safety props before going under the raised reel for any reason.

**⚠ DANGER**

Ensure that all bystanders have cleared the area.

1. Raise the reel fully.
2. Raise the header fully.
3. Shut down the engine, and remove the key from the ignition.
4. Engage the reel safety props. For instructions, refer to [Engaging Reel Safety Props, page 39](#).
5. Engage the header safety props. For instructions, refer to the combine operator's manual.
6. Locate the feed draper tensioner. Loosen jam nut (A). Turn bolt (B) counterclockwise to relieve the tension on the draper.

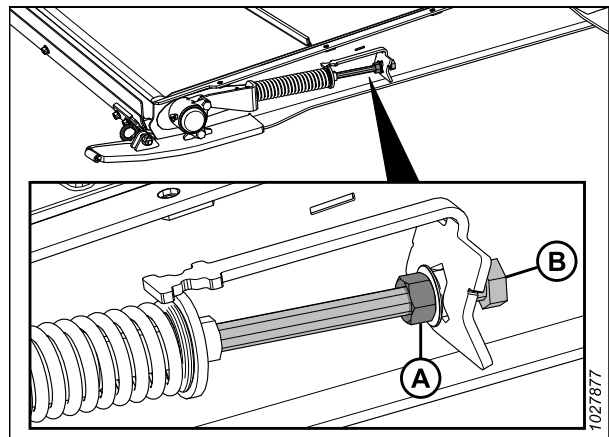


Figure 4.202: Feed Draper Tensioner

## MAINTENANCE AND SERVICING

7. Remove the socket head bolts, washers, and nuts (A) that secure the bearing housing to the deck skid and tensioner.
8. Remove dust cap (B).

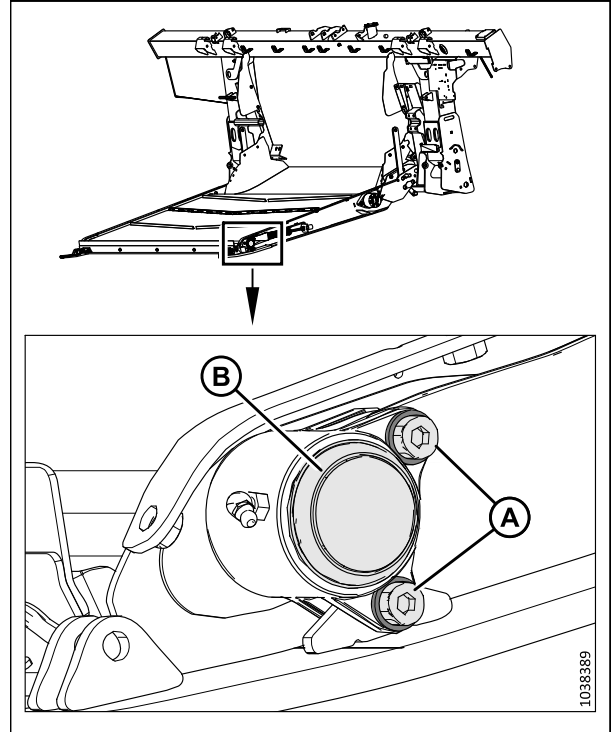


Figure 4.203: Left Idler Roller Bearing

9. Remove nut (A), then remove bearing housing (B) from the deck. Retain the nut and the bearing housing.

**NOTE:**

If the bearing is seized on the shaft, it may be easier to remove the idler roller assembly. For instructions, refer to [Removing Feed Draper Idler Roller, page 682](#).

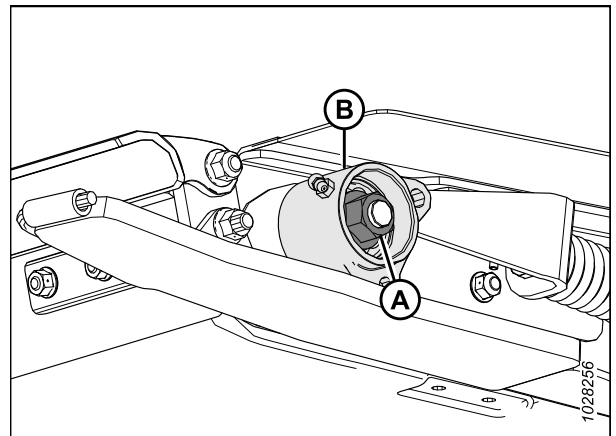


Figure 4.204: Idler Roller Bearing – Left Side

## MAINTENANCE AND SERVICING

10. Remove retaining ring (A), bearing (B), and seals (C) from bearing housing (D).

11. Apply oil to the bore before assembling the parts.

12. Install seals (C) into bearing housing (D).

**NOTE:**

Ensure that the flat side of the seal is facing inward.

13. Lubricate bearing (B) with grease, then install the bearing as shown.

14. Install retaining ring (A).

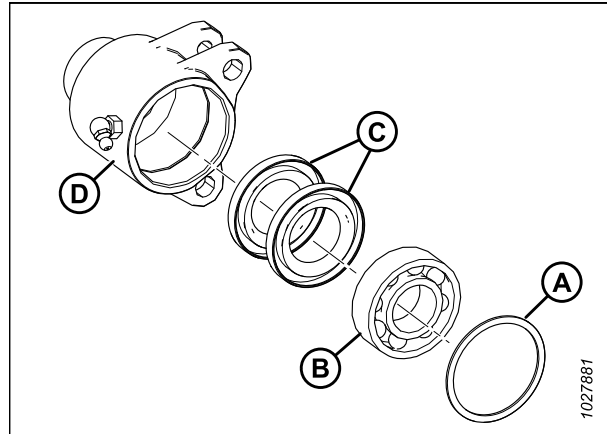


Figure 4.205: Bearing Assembly

15. Brush idler roller shaft (A) with oil.

16. Carefully rotate bearing assembly (B) onto shaft (A) by hand to prevent damage to the seal.

**IMPORTANT:**

Ensure that the bearing assembly is square to the shaft to prevent damage to the seal during installation.

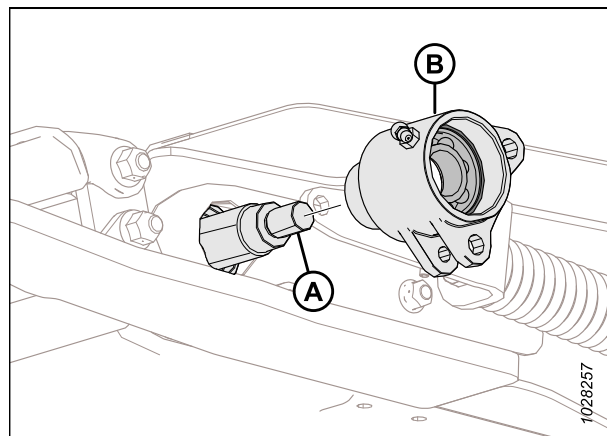


Figure 4.206: Idler Roller Bearing – Left Side

17. After installing the bearing and both of the seals around the shaft, install nut (A) and torque the nut to 81 Nm (60 lbf-ft).

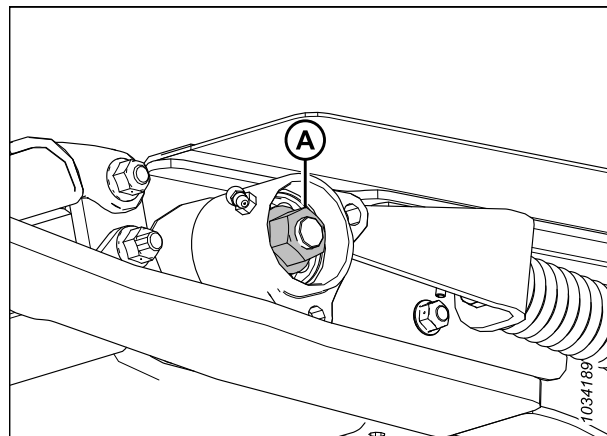


Figure 4.207: Idler Roller Bearing – Left Side

18. Rotate idler roller housing (A) until the holes in the lower tabs align with the hole in welded tab (B).
19. Apply medium-strength threadlocker (Loctite® 243 or equivalent) to the threads of the socket head bolt, then install the bolt, the washer, and the nut at location (C).
20. Align the hole in cast support (D) with the holes in the upper tab on idler roller housing (A).
21. Apply medium-strength threadlocker (Loctite® 243 or equivalent) to the threads of the socket head bolt, then install the bolt, the washer, and the nut at location (E).
22. Tighten bolts (C) and (E) to 12 Nm (8.85 lbf-ft [106 lbf-in]).

**IMPORTANT:**

Do **NOT** overtighten bolts (C) and (E).

23. Repeat Step 7, [page 689](#) to Step 22, [page 691](#) on the opposite side.
24. Fill the bearing cavity with grease, then install dust cap (A) on both ends of the idler roller.
25. Ensure that the grease fitting is working.
26. Repeat Step 24, [page 691](#) to Step 25, [page 691](#) on the opposite side.
27. Tension the feed draper. For instructions, refer to [4.10.2 Checking and Adjusting Feed Draper Tension, page 674](#).

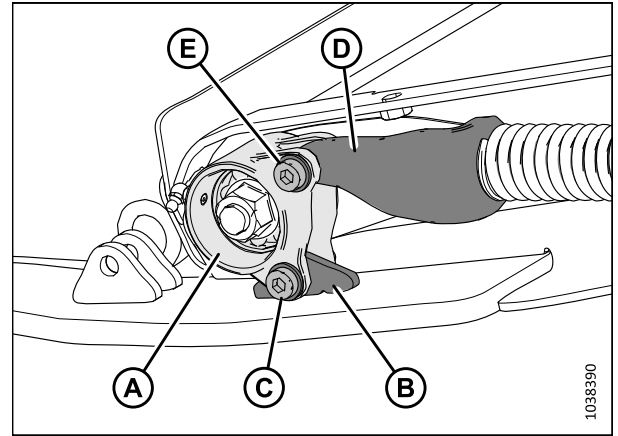


Figure 4.208: Idler Roller Bearing – Left Side

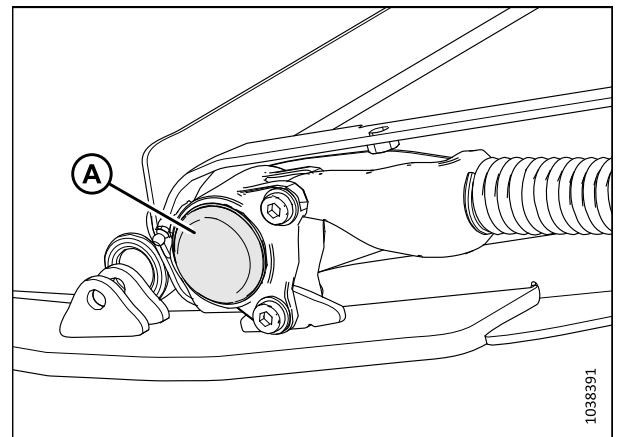


Figure 4.209: Feed Deck – Left Side

### 4.10.5 Lowering Feed Deck Pan

The feed deck pan protects the feed draper from items on the ground. It can be opened and closed to access the feed draper.

**⚠ DANGER**

To prevent bodily injury or death from the unexpected start-up or fall of a raised machine, always stop the engine and remove the key before leaving the operator's seat, and always engage the safety props before going under the machine for any reason.

**⚠ DANGER**

Ensure that all bystanders have cleared the area.

1. Raise the header fully.
2. Shut down the engine, and remove the key from the ignition.

## MAINTENANCE AND SERVICING

3. Engage the header safety props. For instructions, refer to the combine operator's manual.
4. On the underside of the feed deck, rotate latch (A) to unlock handle (B). Repeat this step on the opposite end of the feed deck.

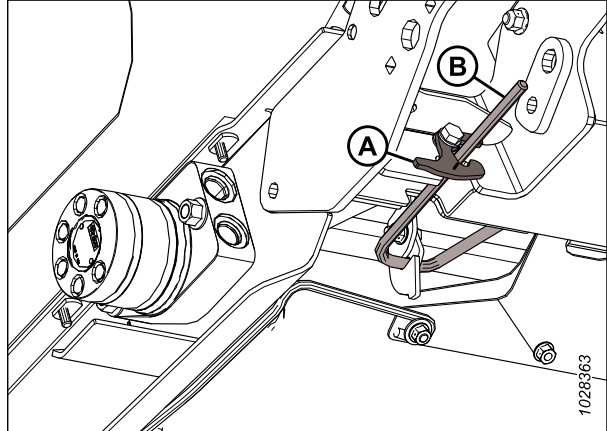


Figure 4.210: Underside of Feed Deck

5. Hold pan (A) and rotate handle (B) downward to release the pan.

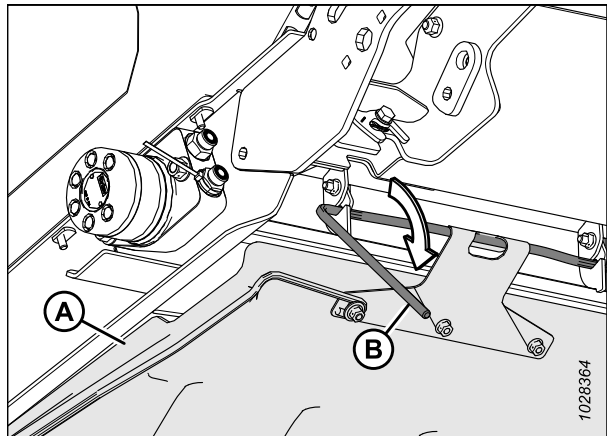


Figure 4.211: Underside of Feed Deck

6. Lower feed deck pan (A).

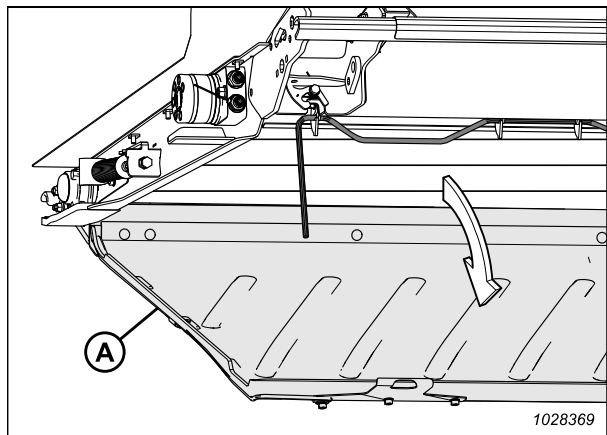


Figure 4.212: Feed Deck Pan

### 4.10.6 Raising Feed Deck Pan

The feed deck pan protects the feed draper from items on the ground. It can be opened and closed to access the feed draper.

**⚠ DANGER**

To prevent bodily injury or death from the unexpected start-up or fall of a raised machine, always stop the engine and remove the key before leaving the operator's seat, and always engage the safety props before going under the machine for any reason.

1. Raise feed deck pan (A).

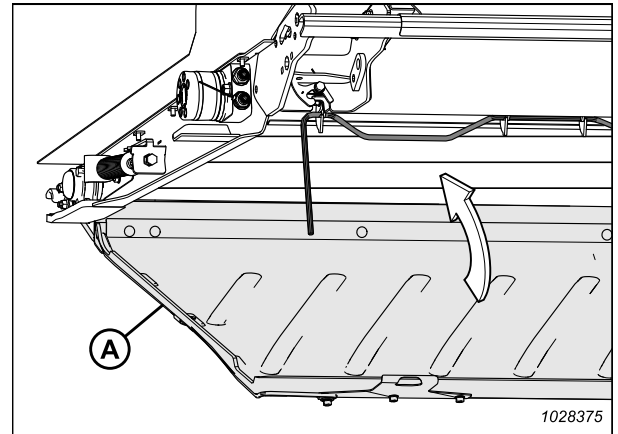


Figure 4.213: Feed Deck Pan

2. Engage lock handle (A) in three feed deck pan hooks (B).

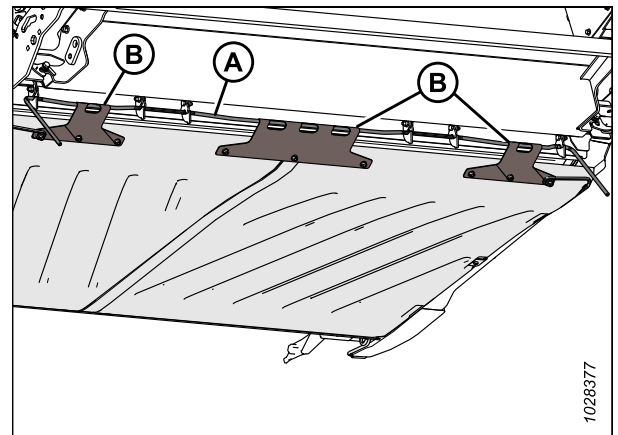


Figure 4.214: Underside of Feed Deck Pan

3. Rotate handles (A) upwards, bringing the feed deck pan into the locked position.

**NOTE:**

Ensure that all three deck pan hooks (B) are secured on the lock handle.

4. Hold the feed deck pan in place, and rotate latch (C) to lock handle (A).

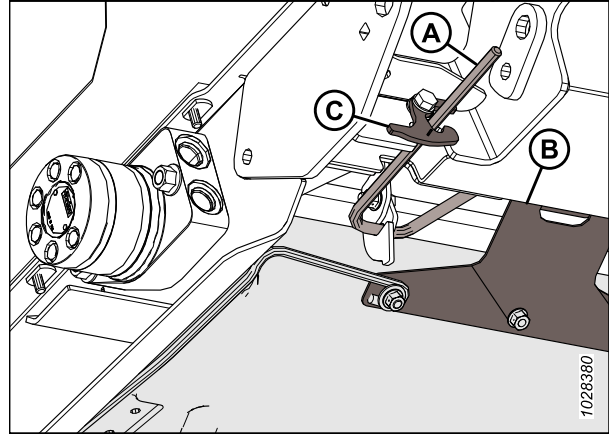


Figure 4.215: Underside of Feed Deck Pan

### 4.10.7 Checking Link Holder Hooks

Check the left and the right link holder hooks **DAILY** to ensure that they are not cracked or broken.

**! DANGER**

To prevent bodily injury or death from the unexpected start-up or fall of a raised machine, always stop the engine, remove the key, and engage the safety props before going under the header for any reason.

**! DANGER**

Ensure that all bystanders have cleared the area.

1. Raise the header fully.
2. Shut down the engine, and remove the key from the ignition.
3. Engage the header safety props. For instructions, refer to the combine operator's manual.
4. Before operation, ensure that both link holder hooks (A) are engaged on the float module under the feed deck.

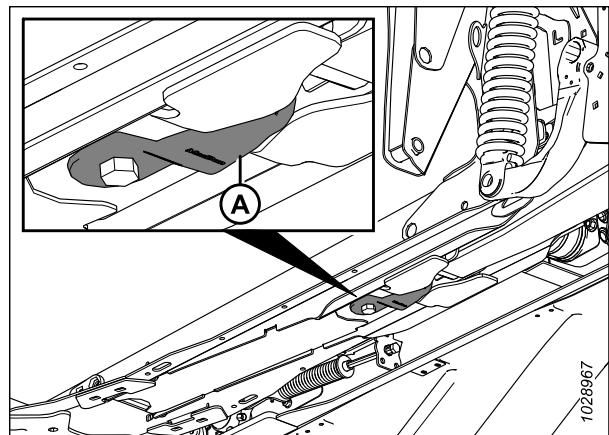


Figure 4.216: Feed Deck – View from Below



## MAINTENANCE AND SERVICING

### NOTE:

Figure 4.217, page 695 shows an undamaged link holder hook (A) and a damaged link holder hook (B). A stretched link holder hook is not shown.

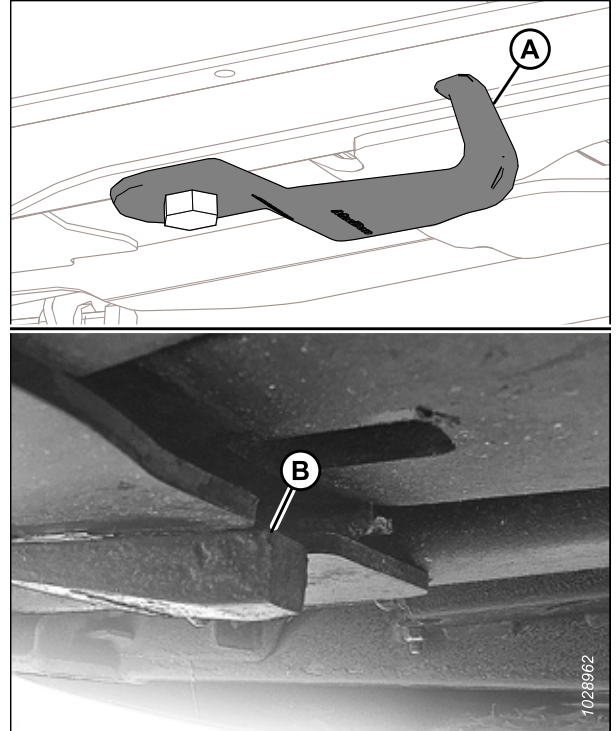


Figure 4.217: Link Holder Hooks

### NOTE:

To move hook (A) to the storage position, loosen bolt (B) and rotate the hook by 90°.

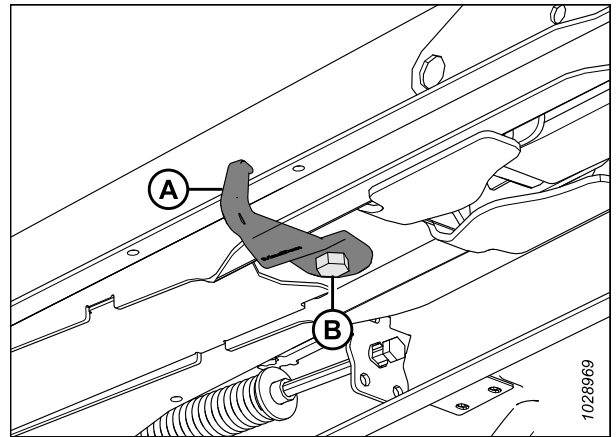


Figure 4.218: Link Holder Hook in Storage Position

## 4.11 Stripper Bars

Stripper bars are installed into the float module opening to improve feeding in crops such as rice. They may need to be removed depending on the desired float module configuration.

### 4.11.1 Removing Stripper Bars

The stripper bars are secured to the float module frame with four bolts and nuts.

1. Detach the header from the combine. For instructions, refer to [3.6 Header Attachment/Detachment, page 74](#).
2. Remove four bolts and nuts (A) securing stripper bar (B) to the float module frame, and remove the stripper bar.

**NOTE:**

There may only be two upper bolts on stripper bar (B).

3. Repeat the previous step on the opposite side of the float module.

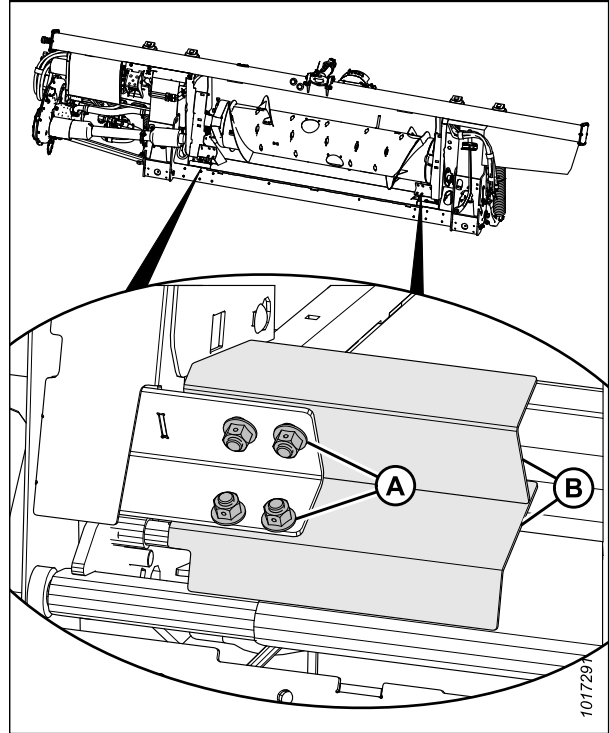


Figure 4.219: Stripper Bars

### 4.11.2 Installing Stripper Bars

The stripper bars are installed in the lower corners of the float module opening.

1. Detach the header from the combine. For instructions, refer to [3.6 Header Attachment/Detachment, page 74](#).

## MAINTENANCE AND SERVICING

2. Position stripper bar (B) as shown so the notch is at the corner of the frame.
3. Secure stripper bar (B) to the float module with four bolts and nuts (A). Ensure that the nuts face the combine.

**NOTE:**

If the lower bolts and nuts are too difficult to install, install the upper two bolts only.

4. Repeat Step 2, [page 697](#) and Step 3, [page 697](#) on the opposite side of the float module.

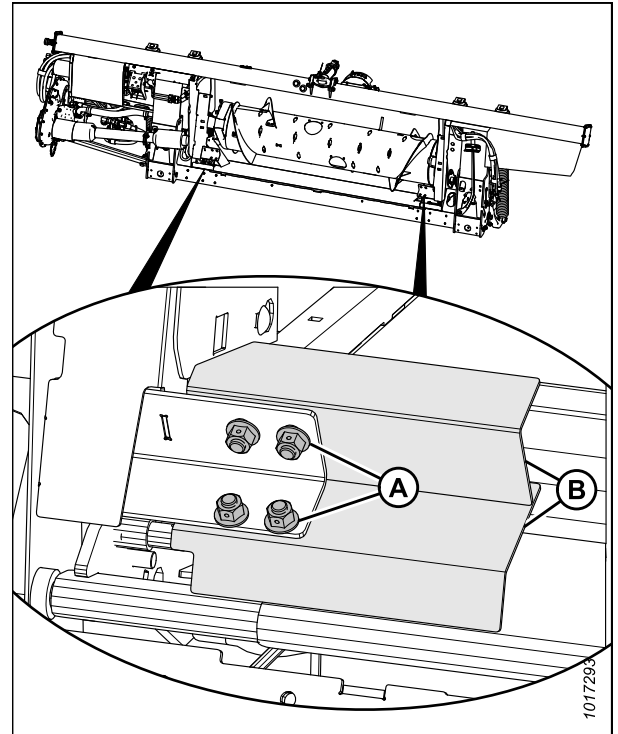


Figure 4.220: Stripper Bars

## 4.12 Header Side Drapers

There are two drapers, one on each side of the header. They convey cut crop to the float module feed draper and auger. Replace the drapers if they are torn, cracked, or missing slats.

### 4.12.1 Removing Side Drapers

Replace the drapers if they are torn, cracked, or missing slats.

#### DANGER

To prevent bodily injury or death from the unexpected start-up or fall of a raised machine, always stop the engine and remove the key before leaving the operator's seat, and always engage the safety props before going under the machine for any reason.

#### DANGER

Ensure that all bystanders have cleared the area.

#### WARNING

To prevent bodily injury from the fall of a raised reel, always engage the reel safety props before going under the raised reel for any reason.

1. Raise the reel fully.
2. Raise the header fully.
3. Shut down the engine, and remove the key from the ignition.
4. Engage the header safety props. For instructions, refer to the combine operator's manual.
5. Engage the reel safety props. For instructions, refer to [Engaging Reel Safety Props, page 39](#).
6. Rotate the draper until you can access the draper joint.

## MAINTENANCE AND SERVICING

7. Locate draper tension adjuster (A).
8. Turn bolt (B) counterclockwise to decrease the tension on the draper. Tension indicator (C) will move outboard to show that the draper is loosening.

**IMPORTANT:**

To avoid premature failure of the draper, draper rollers, and/or tightener components, do **NOT** operate the header when the tension indicator is not visible.

**IMPORTANT:**

Do **NOT** adjust nut (D). This nut is used for draper alignment only.

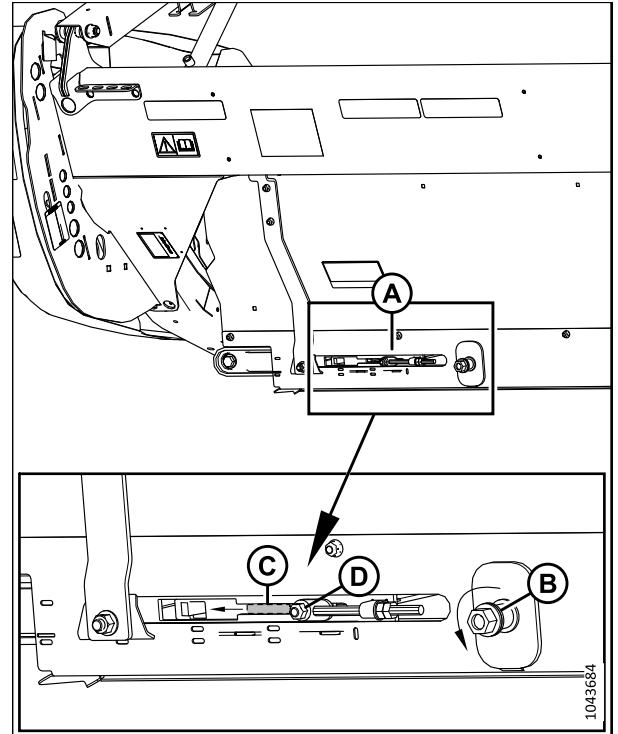


Figure 4.221: Adjusting Left Tensioner

9. Remove nuts and screws (A), and tube connectors (B) from the draper joint.
10. Remove screws (C), bridge connector (D), and nuts from the front end of the draper joint.
11. Pull the draper from the deck.

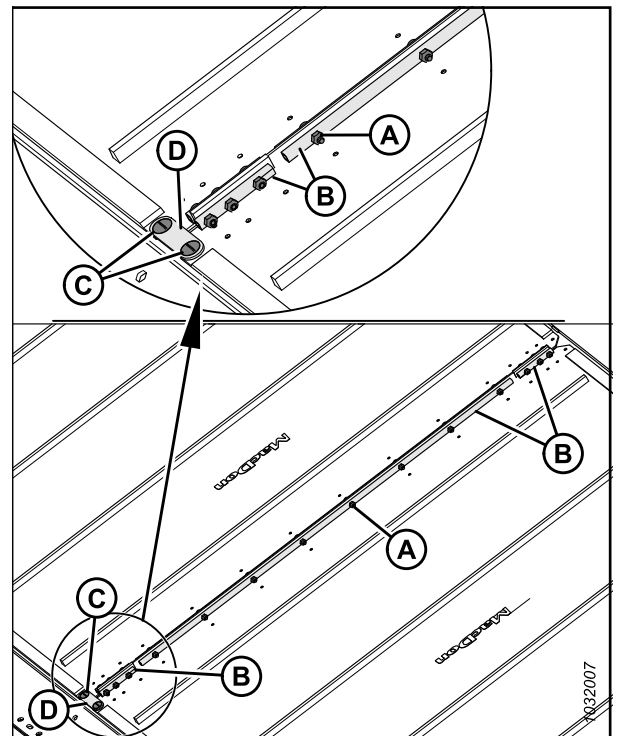


Figure 4.222: Draper Connectors

## 4.12.2 Installing Side Drapers

The side drapers bring cut crop to the center of the header.

### DANGER

To prevent bodily injury or death from the unexpected start-up or fall of a raised machine, always stop the engine and remove the key before leaving the operator's seat, and always engage the safety props before going under the machine for any reason.

### DANGER

Ensure that all bystanders have cleared the area.

### WARNING

To prevent bodily injury from the fall of a raised reel, always engage the reel safety props before going under the raised reel for any reason.

1. Raise the reel fully.
2. Raise the header fully.
3. Shut down the engine, and remove the key from the ignition.
4. Engage the header safety props. For instructions, refer to the combine operator's manual.
5. Engage the reel safety props. For instructions, refer to *Engaging Reel Safety Props, page 39*.
6. Apply talcum powder to the underside of the draper guides and to the draper surface that forms the seal with the cutterbar.
7. Remove first inboard seal.
8. Place draper on feed draper deck and insert it into inboard end of side deck under drive roller. Pull draper into the deck while feeding it.
9. Feed in the draper until it can be wrapped around the drive roller.

#### NOTE:

If you are performing this job alone, it will be easier to feed the draper into the side deck if you lower the front of the feed deck to increase the vertical gap between the side deck and the feed deck.

10. Insert the ends of the draper into the top of the deck, under the seals, and over the rollers.
11. Reinstall the first inboard seal removed in Step 7, *page 700*.

- Attach the ends of the draper with tube connectors (B), screws (A) (with the heads facing the center opening), and nuts.

**NOTE:**

The two short tube connectors are attached at the front and the rear of the draper.

- Install bridge connector (D) using screws (C) and the nuts at the front end of the draper joint.

**NOTE:**

Hold screws (C) at a 90° angle to bridge connector (D) while tightening the nuts. Holding the screws will prevent the bridge connector from bowing up.

- Torque the nuts to 9.5 Nm (7 lbf·ft [84 lbf·in]).
- Adjust the draper tension. For instructions, refer to [4.12.4 Adjusting Side Draper Tension, page 703](#).
- Operate the drapers with the engine at an idle so that the talcum powder adheres to the draper seal surfaces.

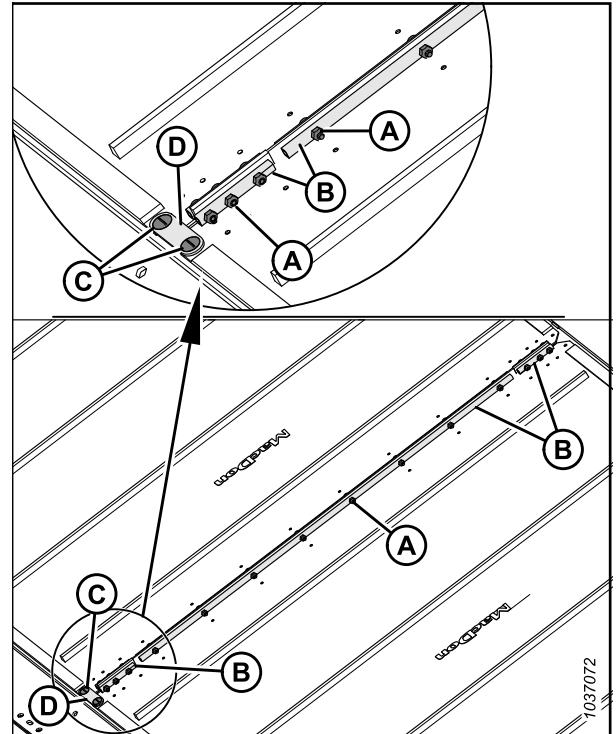


Figure 4.223: Draper Connectors

### 4.12.3 Adjusting Side Draper Deck Height

A properly adjusted deck height will prevent material from entering into the side drapers and stalling them.

**! DANGER**

To prevent bodily injury or death from the unexpected start-up or fall of a raised machine, always stop the engine, remove the key, and engage the safety props before going under the header for any reason.

**IMPORTANT:**

New factory-installed drapers are pressure and heat checked at the factory. The gap between the draper and the cutterbar is set to 1–3 mm (0.04–0.12 in.).

- Lower the header onto four blocks (A) (305–356 mm [12–14 in.]).

**NOTE:**

Place one block at each end of the header, and one block at each wing hinge point.

- Shut down the engine, and remove the key from the ignition.

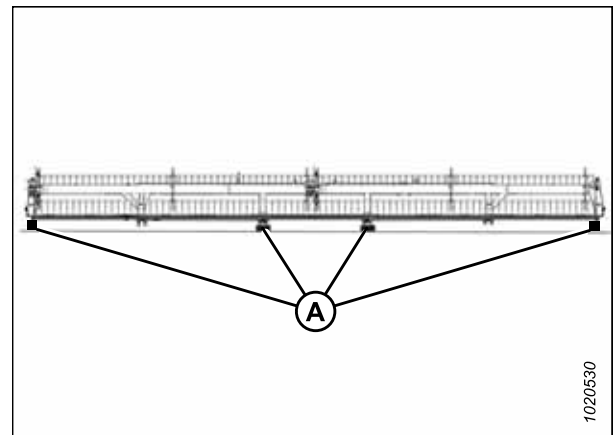


Figure 4.224: Header on Blocks

## MAINTENANCE AND SERVICING

### NOTE:

Take measurements at deck supports (A), refer to illustration at right, when the header is in the working position. Depending on the size of the header, there will be up to seven supports per deck.

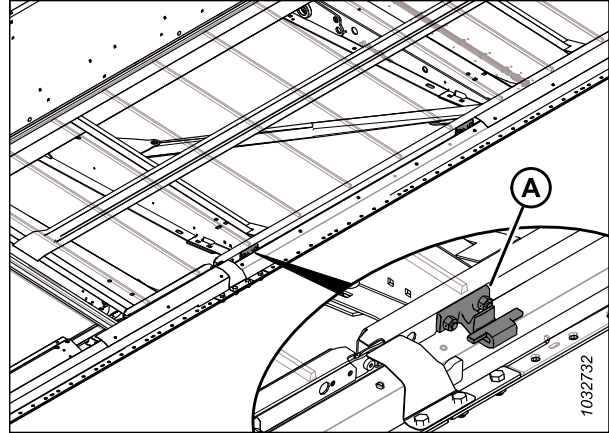


Figure 4.225: Draper Deck Supports

3. Ensure that clearance (A) between draper (B) and metal seal (C) is 1–4 mm (0.04–0.16 in.).
4. Relieve the tension on the draper. For instructions, refer to [4.12.4 Adjusting Side Draper Tension, page 703](#).

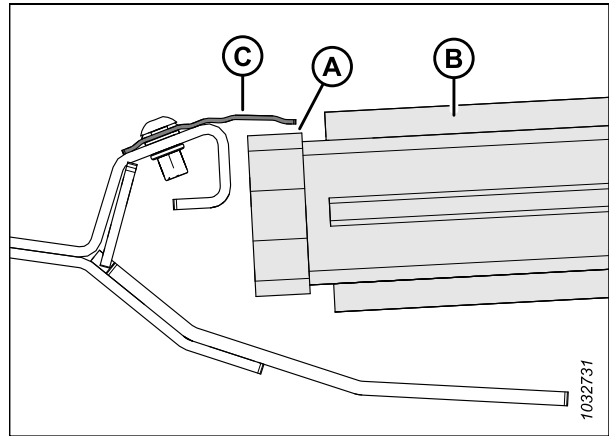


Figure 4.226: Draper Seal

5. Lift front edge of draper (A) past cutterbar (B) to expose the deck support.
6. Measure and note the thickness of the draper belt.

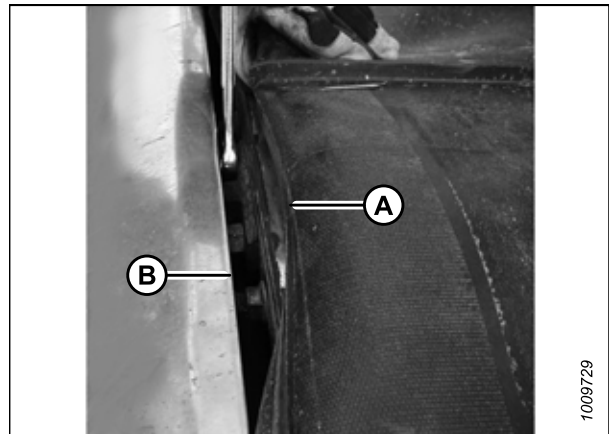


Figure 4.227: Deck Support



**NOTE:**

The draper has been removed in the image to show the deck.

7. Loosen two lock nuts (A) on deck support (B) by one half-turn **ONLY**.
8. Tap deck (C) with a hammer and a block of wood to lower the deck relative to the deck supports. Tap deck support (B) using a punch to raise the deck relative to the deck supports.

**Table 4.1 Total Number of Deck Supports (B)**

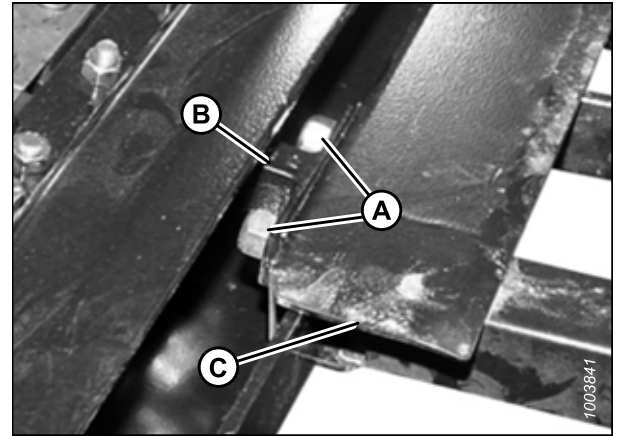
Model	Quantity
FD225	6
FD230	8
FD235, FD240, FD241	10
FD245	12
FD250	14

9. Use a feeler gauge that is the same thickness as the draper belt, plus 1 mm (0.04 in.). Slide the gauge along deck (A) under metal seal (C) to properly set the gap.
10. To create a seal, adjust deck (A) so that clearance (B) between metal seal (C) and the deck is the same thickness as the draper belt plus 1 mm (0.04 in.).

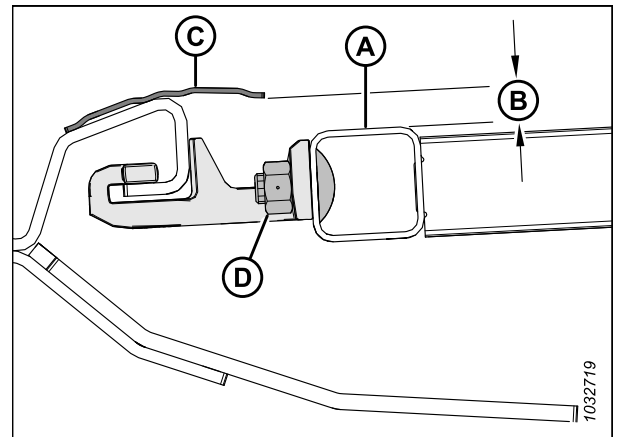
**NOTE:**

To check the clearance at a draper roller, begin measuring from the roller tube, **NOT** the deck.

11. Tighten deck support hardware (D).
12. Recheck gap (B) with the feeler gauge. For instructions, refer to Step 9, page 703.



**Figure 4.228: Deck Support**



**Figure 4.229: Deck Support**

### 4.12.4 Adjusting Side Draper Tension

The tension on the drapers can be adjusted from the end of each draper.

**⚠ DANGER**

To prevent bodily injury or death from the unexpected start-up or fall of a raised machine, always stop the engine, remove the key, and engage the vehicle's safety props before going under the machine for any reason.

**⚠ DANGER**

Ensure that all bystanders have cleared the area.

**IMPORTANT:**

The draper tension is set at the factory, and should not require adjustment. If adjustment is necessary, ensure that the tension is set so that the draper does not slip or sag below the cutterbar. Excessive tension on the draper can damage the draper drive and rollers.

## MAINTENANCE AND SERVICING

1. Ensure that tension indicator (A) covers the inboard half of the window.
2. Raise the header fully.
3. Shut down the engine, and remove the key from the ignition.
4. Engage the header safety props. For instructions, refer to the combine operator's manual.

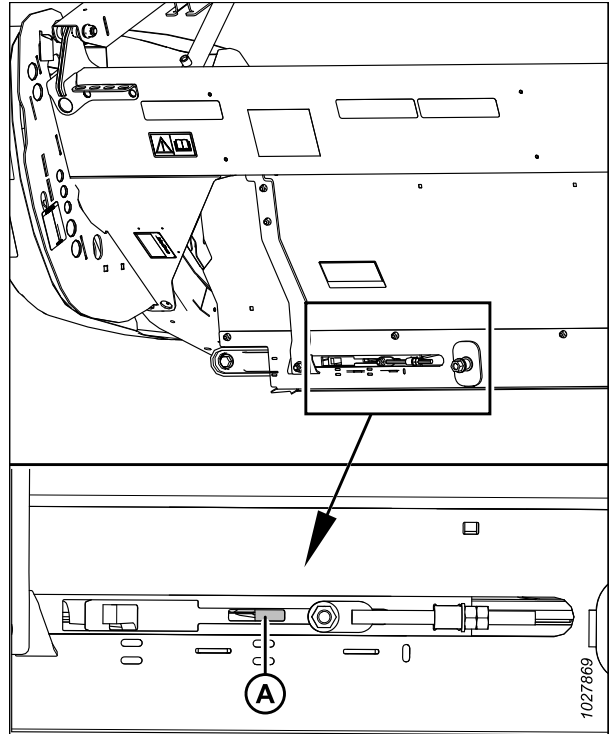


Figure 4.230: Checking Left Tension Adjuster

5. Ensure that the draper guide (the rubber track on the underside of the draper) is engaged in groove (A) of the drive roller.

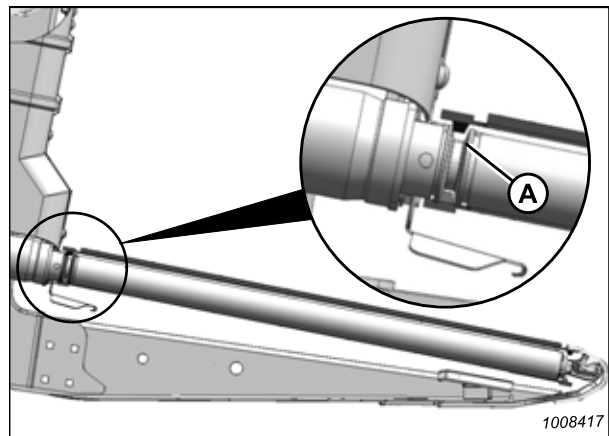


Figure 4.231: Drive Roller

## MAINTENANCE AND SERVICING

6. Ensure that idler roller (A) is between guides (B).

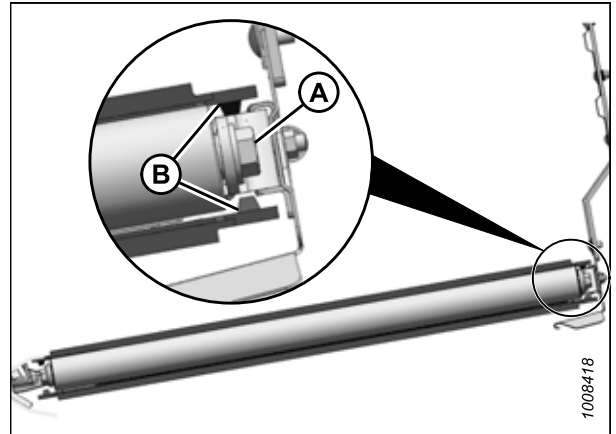


Figure 4.232: Idler Roller

7. Tighten adjuster bolt (A) until the tensioner indicator covers the inboard half of the window. Tensioner indicator (B) will move inboard to show that the draper is tightening.

**IMPORTANT:**

To avoid premature failure of the draper, draper rollers, and/or the tightener components, do **NOT** operate the header when the tension indicator is not visible.

**IMPORTANT:**

Do **NOT** adjust nut (C). This nut is used for draper alignment only.

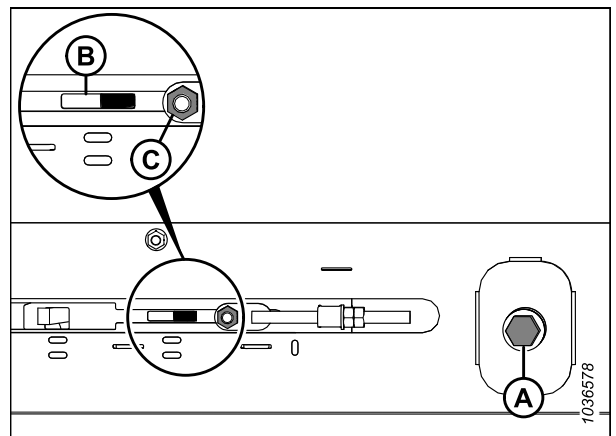


Figure 4.233: Adjusting Left Tensioner

### 4.12.5 Adjusting Side Draper Tracking

If the side drapers rub the header frame during operation, the draper tracking may need to be adjusted.

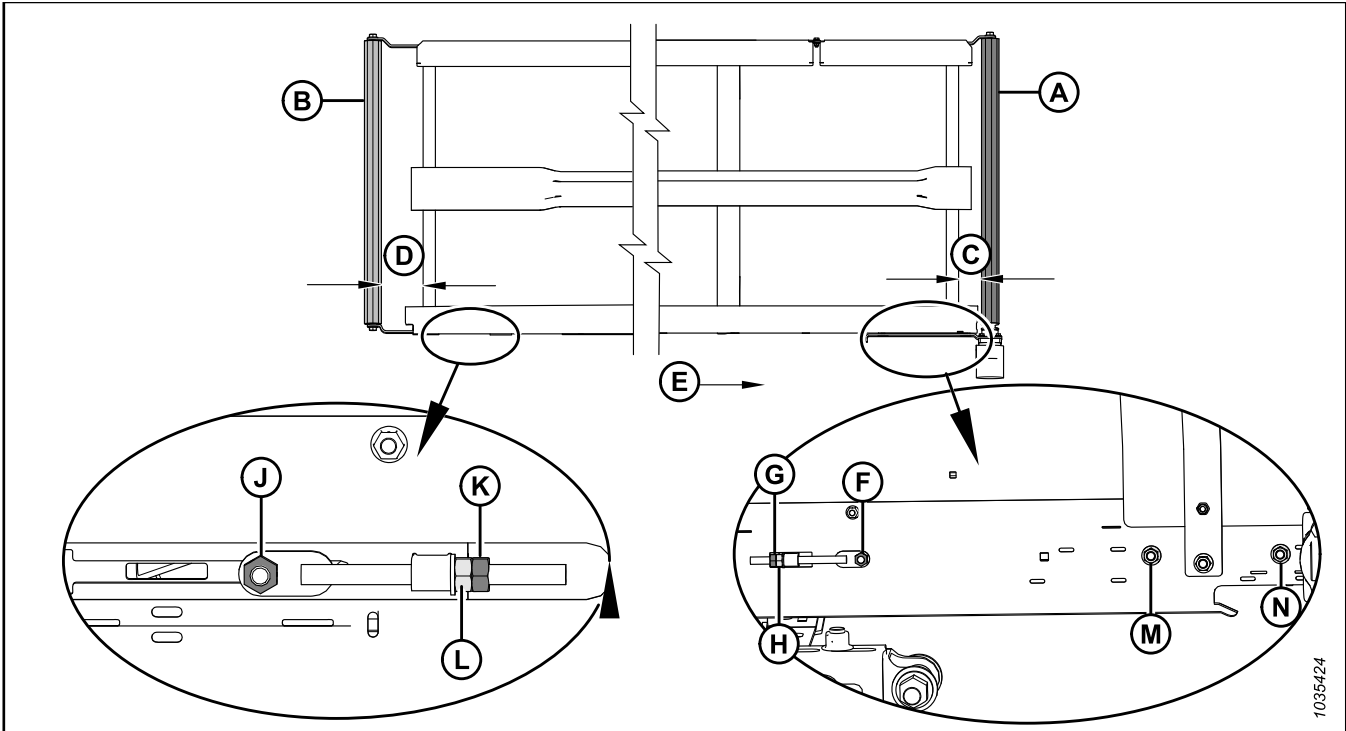


Figure 4.234: Draper Tracking Adjustments – Left Draper

- A - Drive Roller
- B - Idler Roller
- C - Drive Roller Adjust
- D - Idler Roller Adjust
- E - Draper Direction
- F - Nut on Drive Roller Side
- G - Jam Nut for Drive Roller
- H - Adjuster Nut for Drive Roller
- J - Nut on Idler Roller Side
- K - Jam Nut for Idler Roller
- L - Adjuster Nut for Idler Roller
- M - Nut on Drive Roller Side
- N - Nut on Drive Roller Side

1. To determine which roller requires adjustment and which adjustments are necessary, refer to the following table:

Table 4.2 Draper Tracking

If tracking towards	Location	Adjustment	Method
Backsheet	Drive roller	Increase C	Tighten adjuster nut (H)
Cutterbar	Drive roller	Decrease C	Loosen adjuster nut (H)
Backsheet	Idler roller	Increase D	Tighten adjuster nut (L)
Cutterbar	Idler roller	Decrease D	Loosen adjuster nut (L)

## MAINTENANCE AND SERVICING

2. Adjust drive roller (A) to change **C** (refer to Table 4.2, page 706 and Figure 4.234, page 706) as follows:
  - a. Loosen nuts (F), (M), and (N), and jam nut (G).
  - b. Turn adjuster nut (H).
  - c. Tighten nuts (F), (M), and (N), and jam nut (G).
3. Adjust idler roller (B) to change **D** (refer to Table 4.2, page 706 and Figure 4.234, page 706) as follows:
  - a. Loosen nut (J) and jam nut (K).
  - b. Turn adjuster nut (L).

### NOTE:

If the draper does not track at the idler roller end after the idler roller has been adjusted, the drive roller is likely not in line with the deck. Adjust the drive roller, and then readjust the idler roller.

- c. Tighten nut (J) and jam nut (K).

### 4.12.6 Inspecting Draper Roller Bearing

The draper rollers have non-greaseable bearings; however, the external seal should be checked every 200 hours (more frequently in sandy conditions) to achieve maximum bearing life.

Using an infrared thermometer, check for faulty draper roller bearings as follows:

1. Engage the header and run the drapers for approximately 3 minutes.
2. Check the temperature of the draper roller bearings at each of roller arms (A), (B), and (C) on each deck. Ensure that the temperature does not exceed 44°C (80°F) above the ambient temperature.

Replace roller bearings that exceed the maximum recommended temperature. For instructions, refer to:

- [4.12.8 Replacing Side Draper Deck Idler Roller Bearing, page 709](#)
- [4.12.11 Replacing Side Draper Drive Roller Bearing, page 716](#)

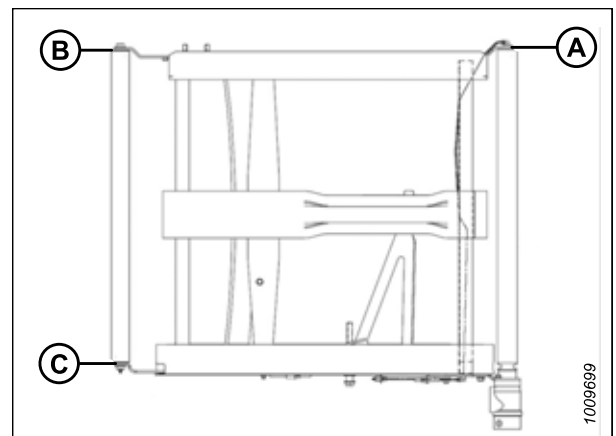


Figure 4.235: Roller Arms

### 4.12.7 Removing Side Draper Deck Idler Roller

The side draper deck has a roller on either end of the deck. One is the idler roller and one is the drive roller.

#### DANGER

To prevent bodily injury or death from the unexpected start-up or fall of a raised machine, always stop the engine and remove the key before leaving the operator's seat, and always engage the safety props before going under the machine for any reason.

#### DANGER

Ensure that all bystanders have cleared the area.

**WARNING**

To prevent bodily injury from the fall of a raised reel, always engage the reel safety props before going under the raised reel for any reason.

1. Engage the header until you can access the side draper connector from the outboard end of the deck.
2. Raise the header fully.
3. Raise the reel fully.
4. Shut down the engine, and remove the key from the ignition.
5. Engage the header safety props. For instructions, refer to the combine operator's manual.
6. Engage the reel safety props. For instructions, refer to *Engaging Reel Safety Props, page 39*.
7. Loosen the draper by turning adjuster bolt (A) counterclockwise until the adjuster bolt hits a hard stop.

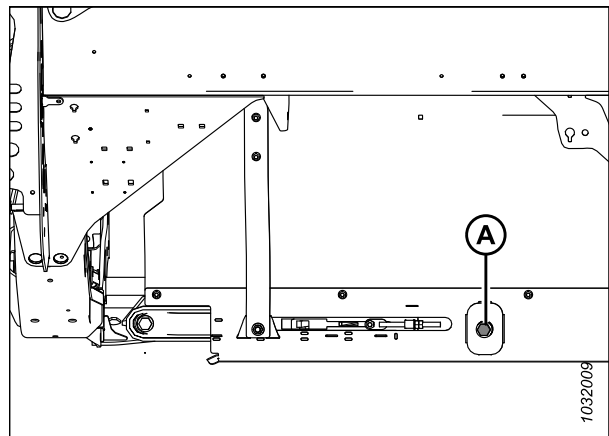


Figure 4.236: Tensioner – Left Side Shown

## MAINTENANCE AND SERVICING

8. Remove screws (C), bridge connector (D), and the nuts from the front end of the draper joint.
9. Remove nuts and screws (A) and tube connectors (B) from the draper joint.
10. Pull the draper off the idler roller.

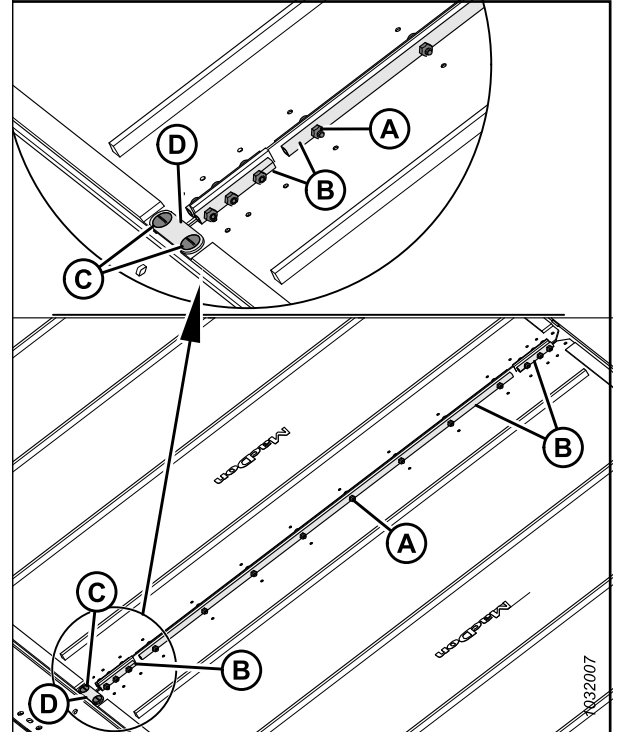


Figure 4.237: Draper Connectors

11. Remove bolt (A) and washer from the idler roller at the back of the header deck.
12. Remove bolt (B) and washer from the idler roller at the front of the header deck.
13. Spread roller arms (C) and (D), and remove the idler roller.

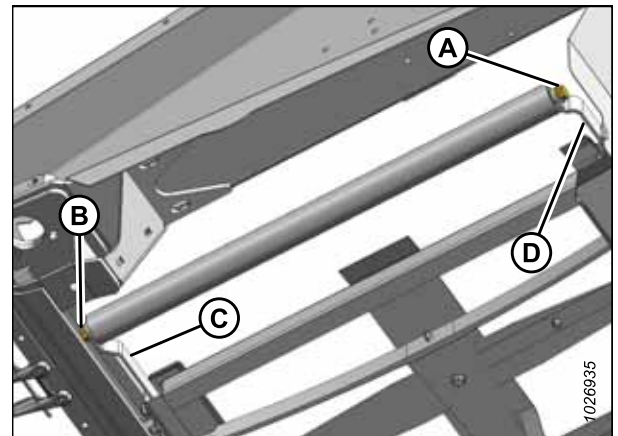


Figure 4.238: Idler Roller

### 4.12.8 Replacing Side Draper Deck Idler Roller Bearing

The side draper deck idler rollers have bearings installed to allow the roller to turn.

1. Remove the draper deck idler roller. For instructions, refer to [4.12.7 Removing Side Draper Deck Idler Roller, page 707](#).

## MAINTENANCE AND SERVICING

2. Clamp idler roller tube (C) in a vise with a cloth wrapped around the roller to prevent damage to the roller.
3. Remove bearing assembly (A) and seal (B) from roller tube (C) as follows:
  - a. Attach slide hammer (D) to threaded shaft (E) in the bearing assembly.
  - b. Tap out bearing assembly (A) and seal (B).
4. Clean the inside of roller tube (C) and check the tube for signs of wear or damage. Replace the tube if necessary.

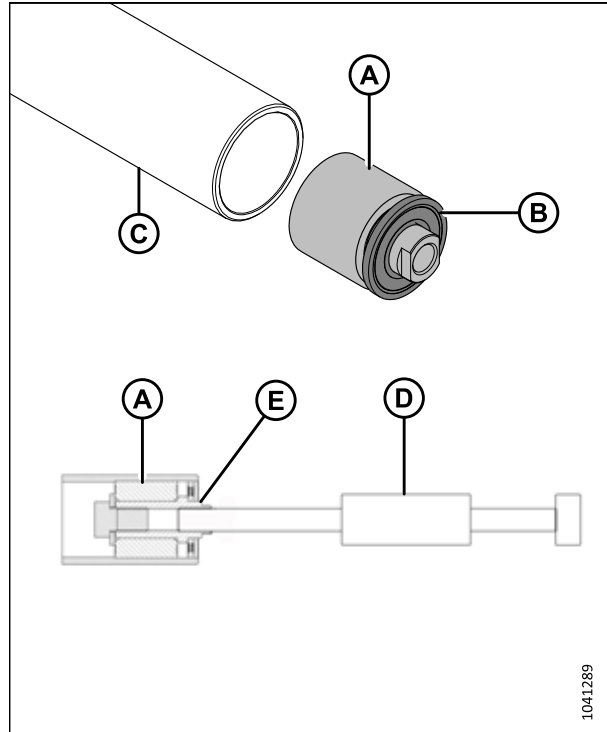


Figure 4.239: Idler Roller Bearing and Seal

### IMPORTANT:

When installing the new bearing, do **NOT** place the end of the roller directly onto the ground. Bearing assembly (A) protrudes past roller tube (B) and placing the end of the roller on the ground will push the bearing farther into the tube.

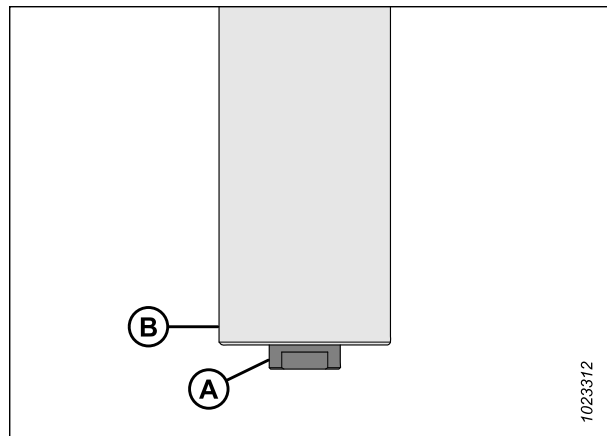


Figure 4.240: Idler Roller



## MAINTENANCE AND SERVICING

5. Cut relief (A) into a block of wood.
6. Place the end of idler roller (B) onto the block of wood, with the protruding bearing assembly inside of relief (A).

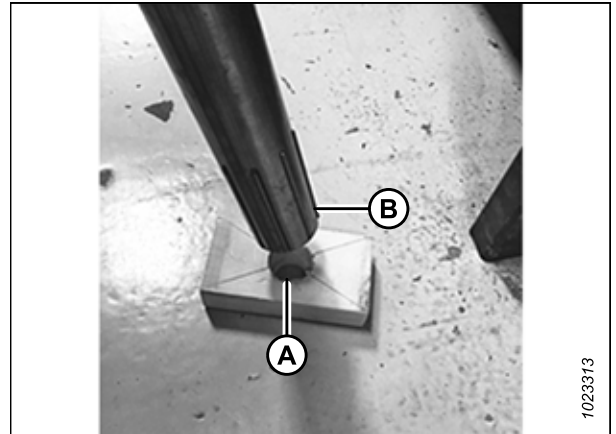


Figure 4.241: Idler Roller

7. Install new bearing assembly (C) by pressing the outer race of the bearing into the tube until it is 14–15 mm (9/16–19/32 in.) (B) from the outside edge of the tube.

**NOTE:**

Before installing a new seal, fill area (A) with approximately 8 pumps of grease.

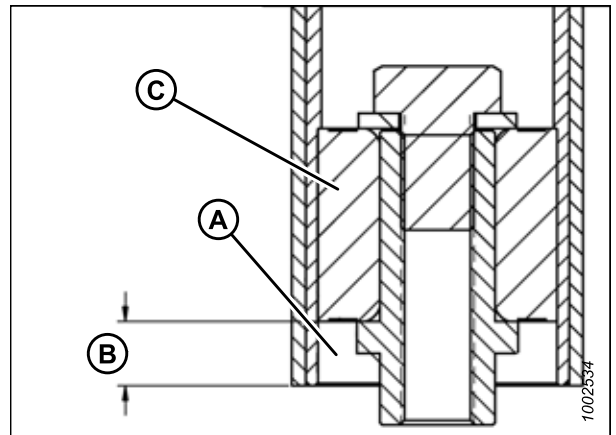


Figure 4.242: Idler Roller Bearing

8. Install new seal (A) by pressing on the inner and outer race of the seal until it is 3–4 mm (1/8–3/16 in.) (B) from the outside edge of the tube.

**NOTE:**

The seal can be oriented in either direction.

9. Reinstall the idler roller. For instructions, refer to [4.12.9 Installing Side Draper Deck Idler Roller, page 712](#).

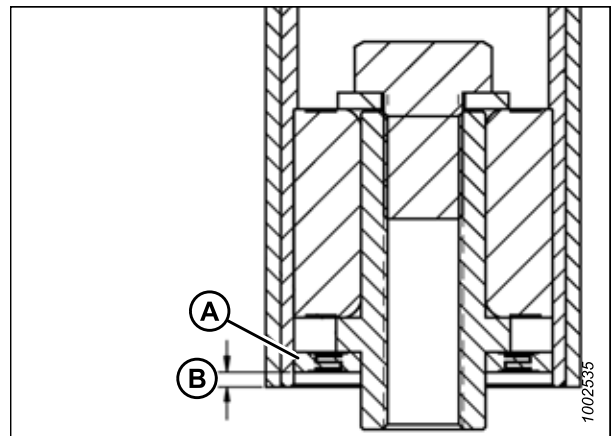


Figure 4.243: Idler Roller Bearing

### 4.12.9 Installing Side Draper Deck Idler Roller

The side draper deck has a roller on each end of the deck. One roller is the idler roller and one roller is the drive roller. If the idler roller is worn or damaged, it will need to be replaced.

**⚠ DANGER**

Ensure that all bystanders have cleared the area.

**⚠ DANGER**

To prevent bodily injury or death from the unexpected start-up or fall of a raised machine, always stop the engine and remove the key before leaving the operator's seat, and always engage the safety props before going under the machine for any reason.

**⚠ WARNING**

To prevent bodily injury from the fall of a raised reel, always engage the reel safety props before going under the raised reel for any reason.

1. Raise the header and the reel.
2. Engage the reel safety props.
3. Engage the header safety props For instructions, refer to the combine operator's manual.
4. Install idler roller (A) between idler arms (B).
5. Secure the idler roller with two bolts and washers (C). Tighten the bolts to 95 Nm (70 lbf·ft).

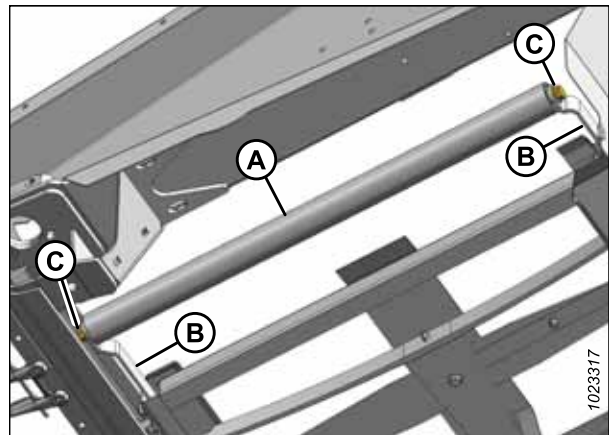


Figure 4.244: Idler Roller

## MAINTENANCE AND SERVICING

- Secure the ends of the draper with tube connectors (B) and screws and nuts (A).

**IMPORTANT:**

Install the screws so that the heads face inboard.

**NOTE:**

The two short tube connectors are attached at the front and rear of the draper.

- Install bridge connector (D) using screws (C) and the nuts at the front end of the draper joint.

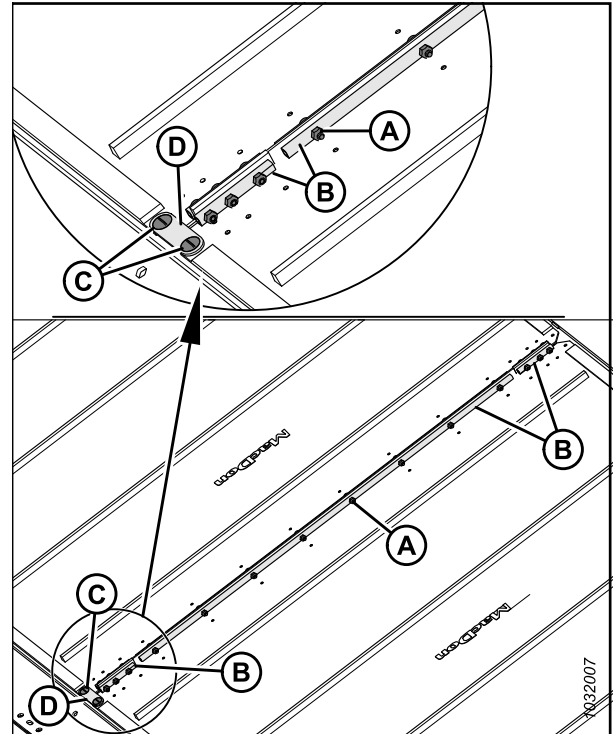


Figure 4.245: Draper Connector

- Tighten the draper by turning adjuster bolt (A) clockwise. For instructions, refer to [4.12.4 Adjusting Side Draper Tension, page 703](#).

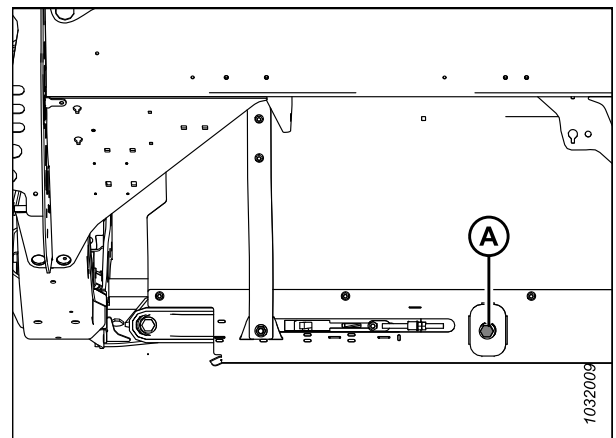


Figure 4.246: Draper Tensioner

- Disengage the reel and the header safety props.
- Start the engine.
- Fully lower the header and the reel.
- Engage the header. Ensure that the side drapers track correctly. For instructions, refer to [4.12.4 Adjusting Side Draper Tension, page 703](#).

### 4.12.10 Removing Side Draper Drive Roller

The side draper deck has a roller on both ends of the deck. One roller is the idler roller and the other roller is the drive roller.

**⚠ DANGER**

To prevent bodily injury or death from the unexpected start-up or fall of a raised machine, always stop the engine and remove the key before leaving the operator's seat, and always engage the safety props before going under the machine for any reason.

**⚠ DANGER**

Ensure that all bystanders have cleared the area.

**⚠ WARNING**

To prevent bodily injury from the fall of a raised reel, always engage the reel safety props before going under the raised reel for any reason.

1. Raise the header fully.
2. Raise the reel fully.
3. If the draper connector is not visible, engage the header until you can access the connector from the outboard end of the deck.
4. Shut down the engine, and remove the key from the ignition.
5. Engage the reel safety props. For instructions, refer to *Engaging Reel Safety Props, page 39*.
6. Engage the header safety props. For instructions, refer to the combine operator's manual.
7. Loosen the draper by turning adjuster bolt (A) counterclockwise until the adjuster bolt hits a hard stop.

**IMPORTANT:**

Do **NOT** adjust nut (B). This nut is used for draper alignment only.

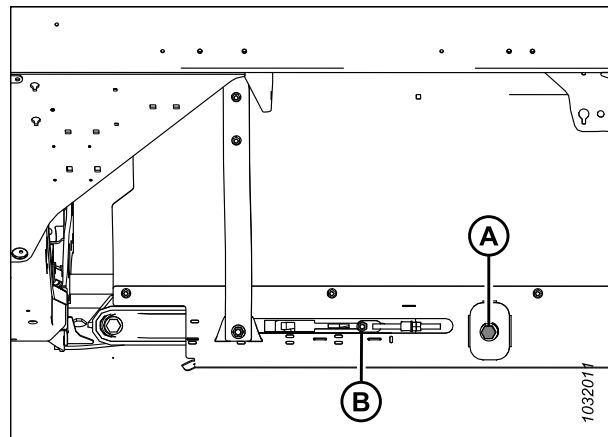


Figure 4.247: Draper Tensioner

## MAINTENANCE AND SERVICING

8. Remove nuts and screws (A), and tube connectors (B) from the draper joint.
9. Remove screws (C), bridge connector (D), and the nuts from the front end of the draper joint.
10. Pull the draper off the drive roller.

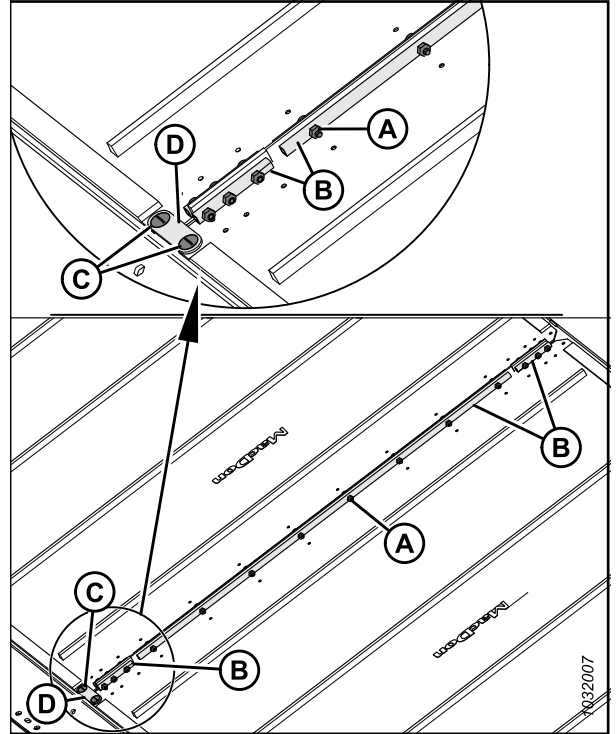


Figure 4.248: Draper Connectors

11. Align the set screws with guard hole (A). Remove the two set screws securing the motor to the drive roller.

**NOTE:**

The set screws are a 1/4 turn apart.

12. Loosen two bolts (B) securing the motor to the drive roller arm.

**NOTE:**

It may be necessary to remove plastic shield (C) to gain access to the top bolt.

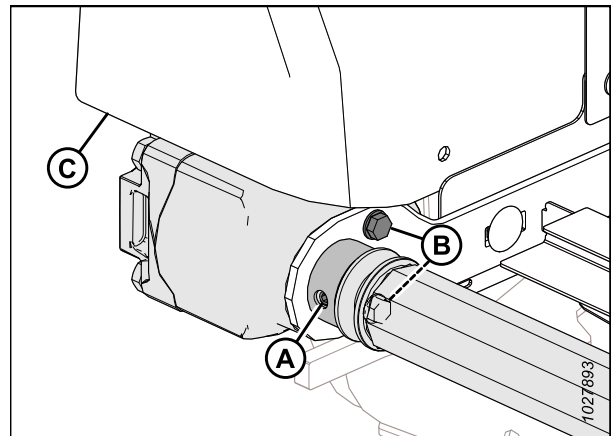


Figure 4.249: Drive Roller

**NOTE:**

It may be necessary to pry between the roller and bracket (A) to remove the roller from shaft. Retain the straight key.

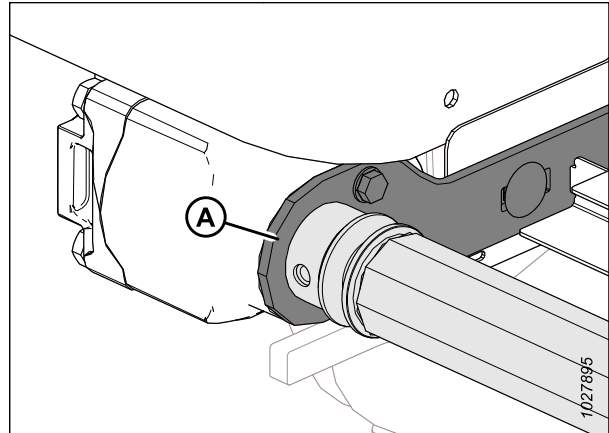


Figure 4.250: Drive Roller

13. Loosen two bolts (A) securing support arm (B).
14. Remove bolt (C) and the washer securing the opposite end of the drive roller to support arm (B).
15. Remove drive roller (D).

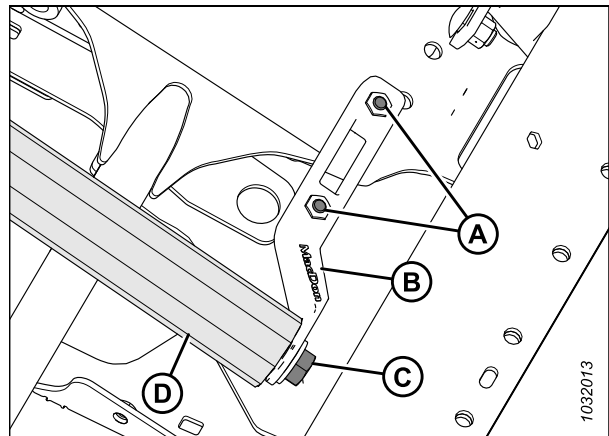


Figure 4.251: Drive Roller

### 4.12.11 Replacing Side Draper Drive Roller Bearing

You will need a slide hammer to replace the bearing on a drive roller.

1. Remove the draper idler roller assembly. For instructions, refer to [4.12.10 Removing Side Draper Drive Roller, page 714](#).
2. Clamp the drive roller in a vise with a cloth wrapped around the roller to prevent damage to the roller.

## MAINTENANCE AND SERVICING

3. Remove bearing assembly (A) and seal (B) from roller tube (C) as follows:
  - a. Attach slide hammer (D) to threaded shaft (E) in the bearing assembly.
  - b. Tap out bearing assembly (A) and seal (B).
4. Clean the inside of roller tube (C), check the tube for signs of wear or damage, and replace it if necessary.

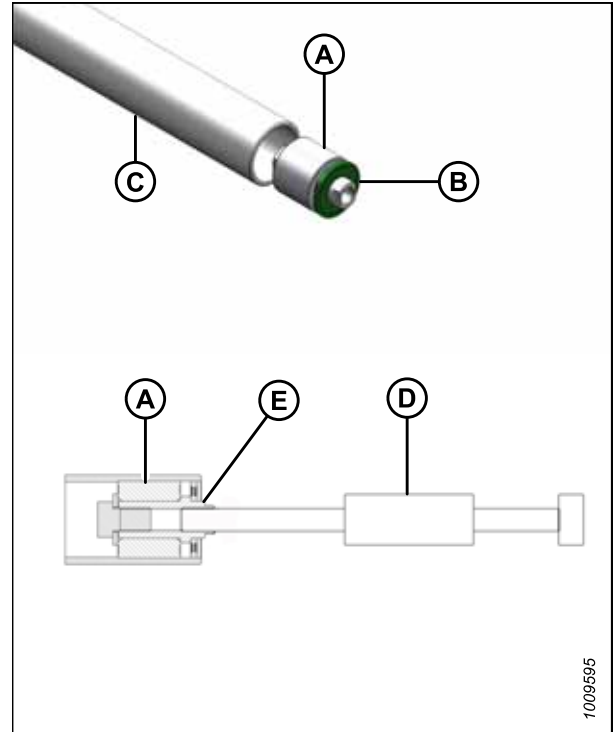


Figure 4.252: Roller Bearing

5. Install new bearing assembly (A) by pressing the outer race of the bearing into the tube until it is 14–15 mm (9/16–19/32 in.) (B) from the outside edge of the tube.
6. Apply grease in front of bearing assembly (A). Refer to the inside back cover of this manual for grease specifications.
7. Install new seal (C) at the roller opening, and install a flat washer (1.0 in. I.D. x 2.0 in. O.D.) on the seal.
8. Tap seal (C) into the roller opening with a suitably sized socket. Tap the washer and bearing assembly (A) until the seal is 3–4 mm (1/8–3/16 in.) (D) from the outside edge of the tube.

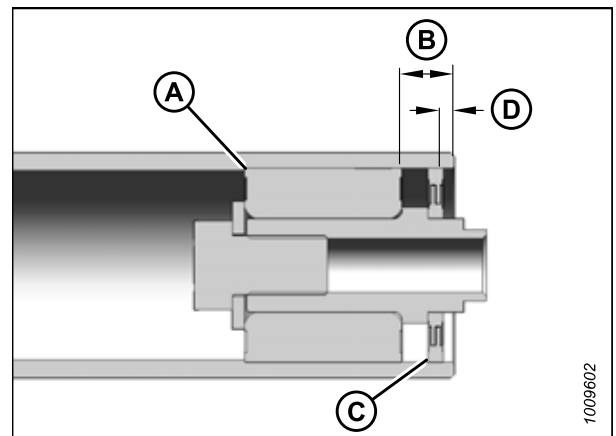


Figure 4.253: Roller Bearing

### 4.12.12 Installing Side Draper Drive Roller

The side draper deck has a roller on either end of the deck. One roller is the idler roller and one roller is the drive roller.

#### DANGER

Ensure that all bystanders have cleared the area.

#### DANGER

To prevent bodily injury or death from the unexpected start-up or fall of a raised machine, always stop the engine and remove the key before leaving the operator's seat, and always engage the safety props before going under the machine for any reason.

**WARNING**

To prevent bodily injury from the fall of a raised reel, always engage the reel safety props before going under the raised reel for any reason.

1. Raise the header and the reel.
2. Engage the reel safety props.
3. Engage the header safety props. For instructions, refer to the combine operator's manual.
4. Position drive roller (A) between the roller support arms.
5. Secure the drive roller with a washer and bolt (B).
6. Tighten bolts (C) on the support arm.
7. Torque bolt (B) to 95 Nm (70 lbf-ft).
8. Lubricate the motor shaft and insert it into the end of drive roller (A).

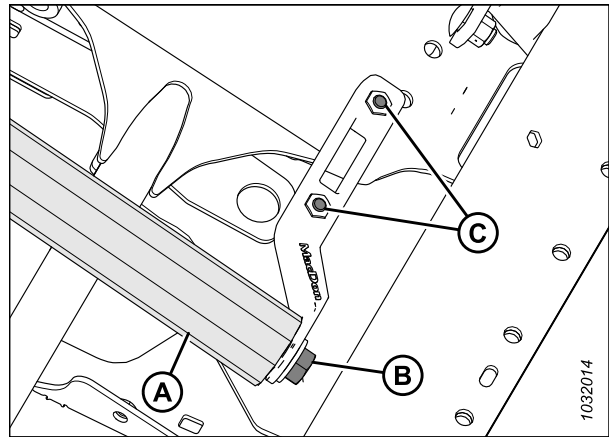


Figure 4.254: Drive Roller

9. Secure the motor to the roller support with two bolts (B). Torque the bolts to 27 Nm (19.9 lbf-ft [239 lbf-in]).
10. Ensure that the straight key is in place on the motor shaft, then insert the motor shaft all the way into the roller.
11. Using a hex key, tighten the two set screws (not shown) through access hole (A).

**NOTE:**

Tighten any loosened bolts and reinstall plastic shield (C), if it was previously removed.

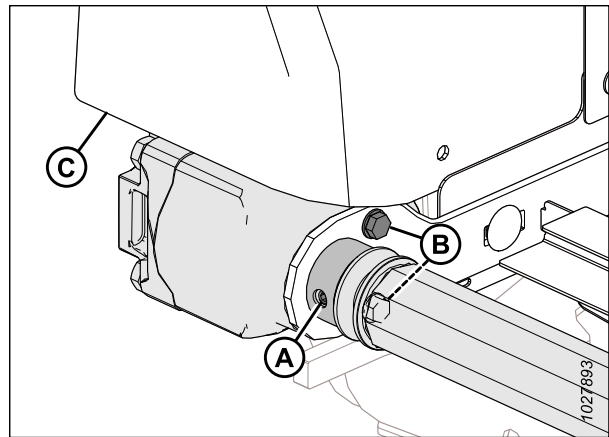


Figure 4.255: Drive Roller



## MAINTENANCE AND SERVICING

12. Wrap the draper over the drive roller and attach the ends of the draper with tube connectors (B), screws (A) (with the heads facing the center opening), and nuts.

**NOTE:**

The two short tube connectors are attached at the front and the rear of the draper.

13. Install bridge connector (D) using screws (C) and the nuts at the front end of the draper joint.

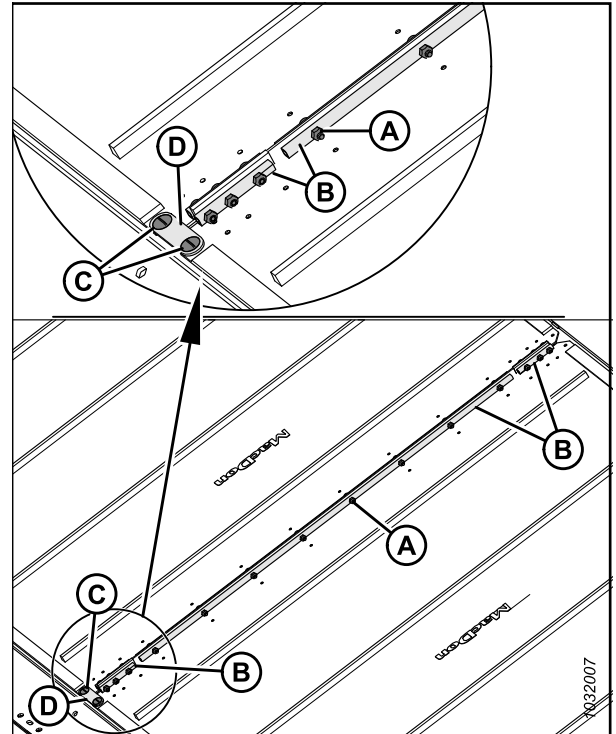


Figure 4.256: Draper Connector

14. Tighten the draper by turning adjuster bolt (A) clockwise. For instructions, refer to [4.12.4 Adjusting Side Draper Tension, page 703](#).

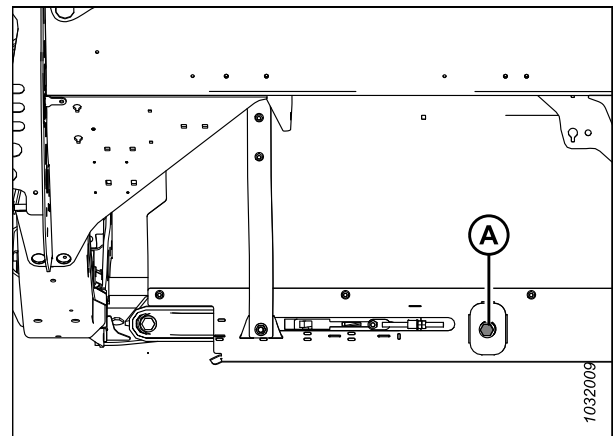


Figure 4.257: Draper Tensioner – Left Side Shown

15. Disengage the reel and the header safety props.
16. Start the engine.
17. Lower the header and the reel.
18. Engage the header. Ensure that the draper tracks correctly. For instructions, refer to [4.12.5 Adjusting Side Draper Tracking, page 706](#).

## 4.13 Reel

The reel features a uniquely shaped cam, which allows the fingers to get underneath lodged crop and pick it up before it is cut.

### CAUTION

To avoid personal injury, before servicing the machine or opening the drive covers, refer to [4.1 Preparing Machine for Servicing, page 567](#).

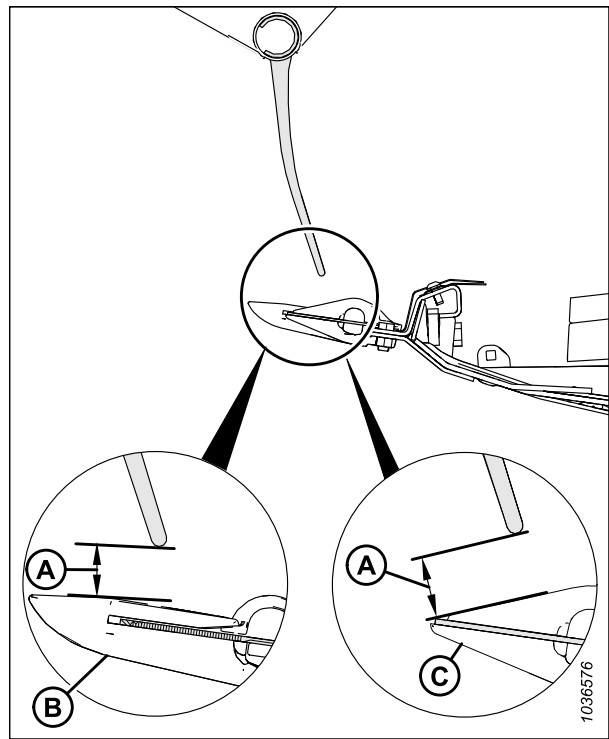
#### 4.13.1 Reel-to-Cutterbar Clearance

There must be a sufficient clearance between the reel fingers and the cutterbar to ensure that the reel fingers do not contact the cutterbar during operation. The clearance is set at the factory, but some adjustment may be necessary before operating the header.

Measure clearance (A) between the tip of the reel finger and the guard (pointed guard [B] or short guard [C], depending on the configuration of the header). Compare the measurement to the specifications listed in the table below:

**Table 4.3 Finger to Guard Clearance**

Header Model	End Panels	At Hinge Point
FD225	40 mm (1.58 in.)	No hinge point
All models except FD225	25 mm (1 in.)	25 mm (1 in.)



**Figure 4.258: Finger Clearance**

#### *Measuring Reel-to-Cutterbar Clearance*

The reel-to-cutterbar clearance refers to the gap between the ends of the reel fingers and the cutterbar. Depending on the configuration of the header, the reel-to-cutterbar clearance can vary across the length of the header. To determine if the clearance is acceptable, it must be measured.

**NOTE:**

This procedure can be performed with the reel fore-aft cylinders in either the standard position or the canola-harvesting position, as long as the fore-aft cylinders remain in the same position for the duration of the procedure.

### DANGER

To prevent injury or death from the unexpected start-up of the machine, always stop the engine and remove the key from the ignition before leaving the operator's seat for any reason.

**⚠ DANGER**

Ensure that all bystanders have cleared the area.

1. Park the combine on a level surface.
2. Adjust the reel fore-aft position until the **7** on fore-aft indicator (A) is hidden by sensor support (B).

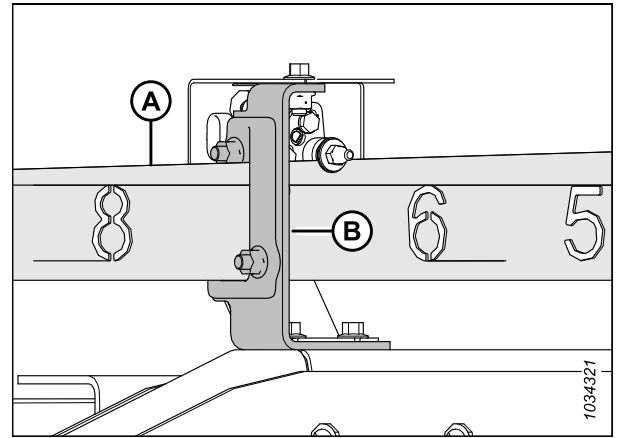


Figure 4.259: Reel Fore-Aft Position

3. **Single-reel headers:** Raise the header high enough to place two 254 mm (10 in.) high blocks (A) under the cutterbar, just inboard of the wing flex points.

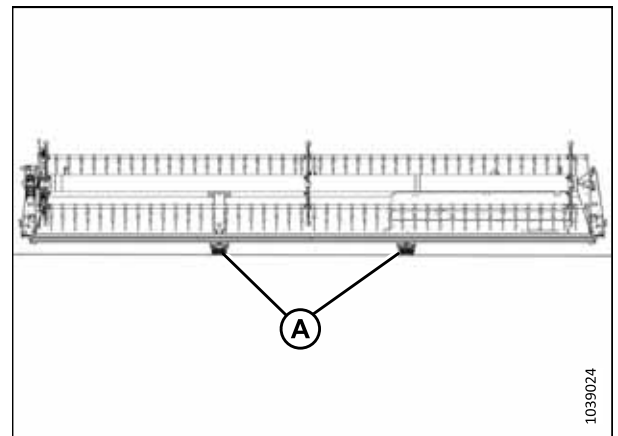


Figure 4.260: FlexDraper® Block Locations – Single Reel

4. **Double-reel headers:** Raise the header high enough to place two 254 mm (10 in.) high blocks (A) under the cutterbar, just inboard of the wing flex points.

**NOTE:**

You do not need blocks to support the wings of triple-reel headers.

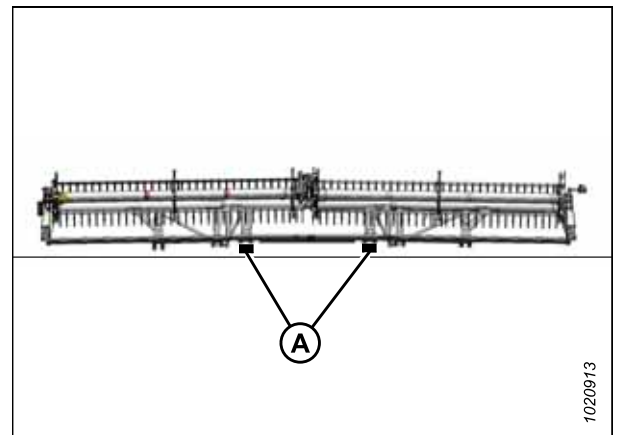


Figure 4.261: FlexDraper® Block Locations – Double-Reel Headers

## MAINTENANCE AND SERVICING

5. **Single-reel and double-reel headers:** Move wing lock spring handles (A) down to the UNLOCK position.

### NOTE:

The reel clearance of triple-reel headers must be measured while the wings are locked.

6. Lower the header until the float indicator is at either position 2 or 3. The wings on single-reel and double-reel headers should be in a full frown position; the wings of triple-reel headers should be level with the center deck.

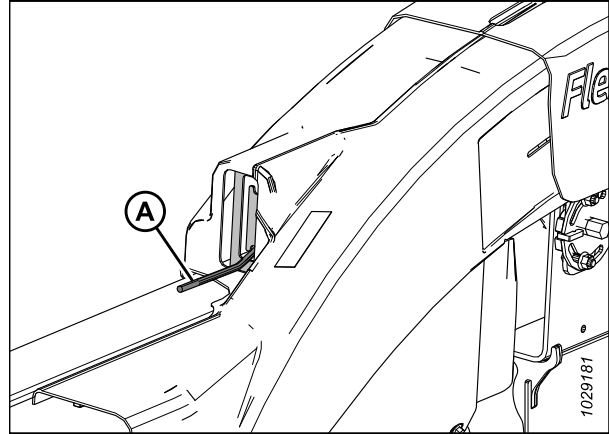


Figure 4.262: Wing Lock in UNLOCK Position

7. Rotate the reel by hand until a tine tube is directly above the cutterbar.
8. Measure and record clearance (A) between the tip of the fingers and one of the guards at the end of the reels, either pointed guard (B) or short guard (C). For the clearance specifications, refer to [4.13.1 Reel-to-Cutterbar Clearance](#), page 720.

For the measurement locations, refer to the relevant figure:

- Single-reel headers: Figure 4.264, page 723
- Double-reel headers: Figure 4.265, page 723
- Triple-reel headers: Figure 4.266, page 723

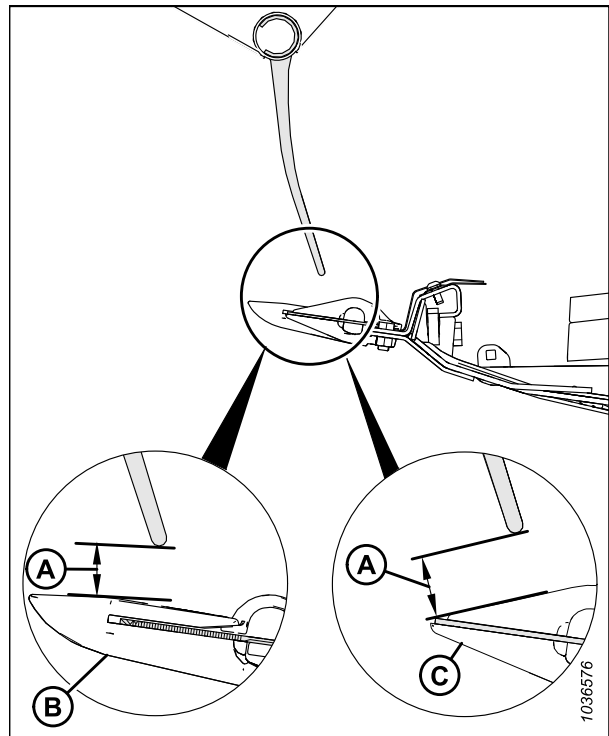


Figure 4.263: Finger Clearance

**Single-reel measurement locations (A):** Outer ends of the reel (two places).

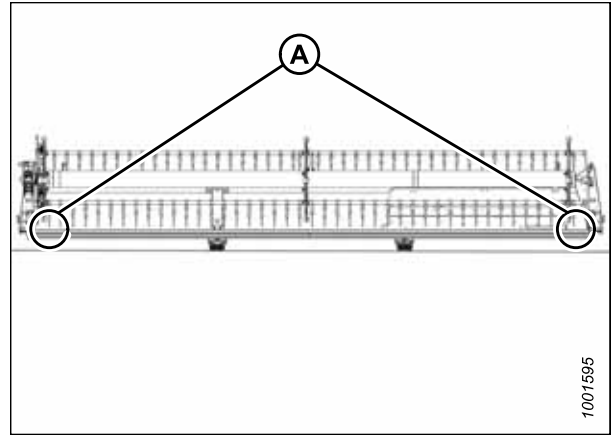


Figure 4.264: FlexDraper® Measurement Locations – Single Reel

**Double-reel measurement locations (A):** Outer ends of the reels and at both hinge points (four places).

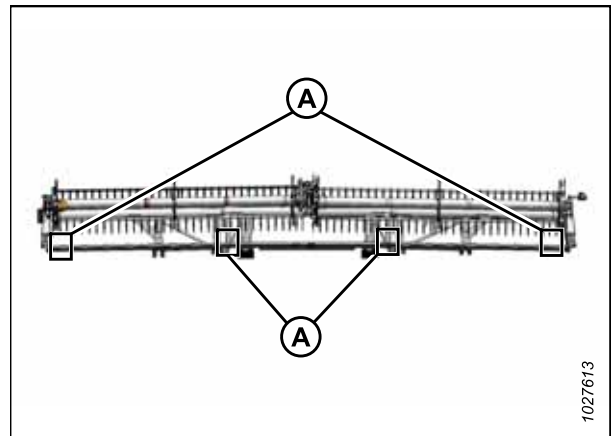


Figure 4.265: FlexDraper® Measurement Locations – Double Reel

**Triple-reel measurement locations (A):** Both ends of three reels (six places).

9. Adjust the reel-to-cutterbar clearance, if necessary. For instructions, refer to [Adjusting Reel-to-Cutterbar Clearance](#), page 724.

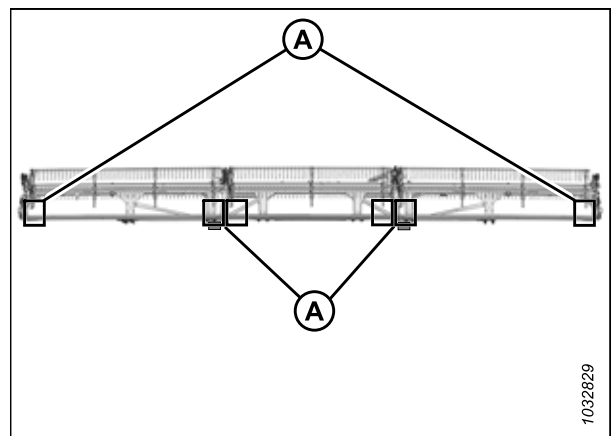


Figure 4.266: FlexDraper® Measurement Locations – Triple Reel

### Adjusting Reel-to-Cutterbar Clearance

If the clearance between the reel fingers and the cutterbar is insufficient, it will need to be adjusted to prevent the equipment from being damaged.

**NOTE:**

This procedure can be performed with the reel fore-aft cylinders in either the standard position or the canola-harvesting position, as long as the fore-aft cylinders remain in the same position for the duration of the procedure.

**⚠ DANGER**

To prevent injury or death from the unexpected start-up of the machine, always stop the engine and remove the key from the ignition before leaving the operator's seat for any reason.

**⚠ DANGER**

Ensure that all bystanders have cleared the area.

1. Measure the reel-to-cutterbar clearance. For instructions, refer to *Measuring Reel-to-Cutterbar Clearance, page 720*.
2. Adjust the reel fore-aft position until the 7 on fore-aft indicator (A) is hidden by sensor support (B).

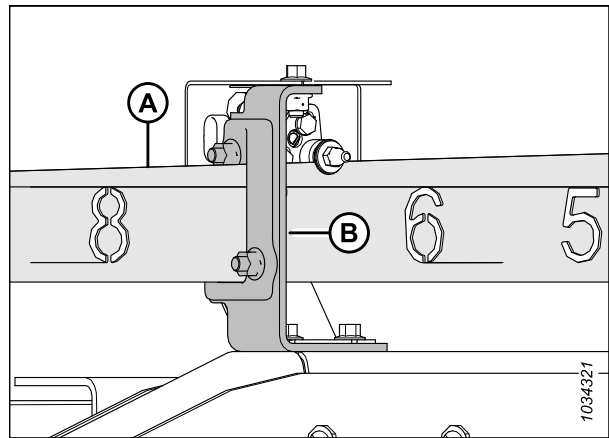


Figure 4.267: Fore-Aft Position

3. Raise the header high enough to place two 254 mm (10 in.) high blocks (A) under the cutterbar, just inboard of the wing flex points.

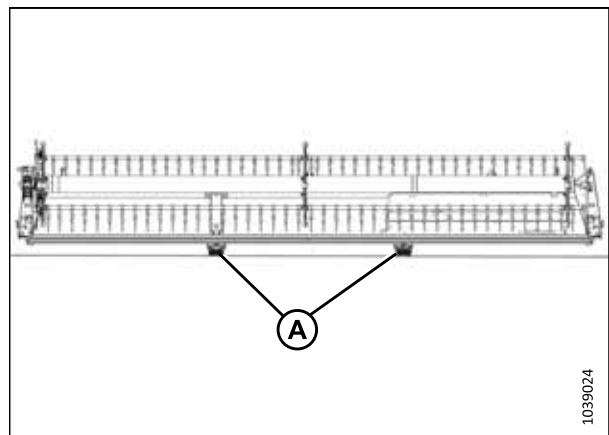


Figure 4.268: FlexDraper® Block Locations – Single Reel

## MAINTENANCE AND SERVICING

4. Raise the header high enough to place two 254 mm (10 in.) high blocks (A) under the cutterbar, just inboard of the wing flex points.

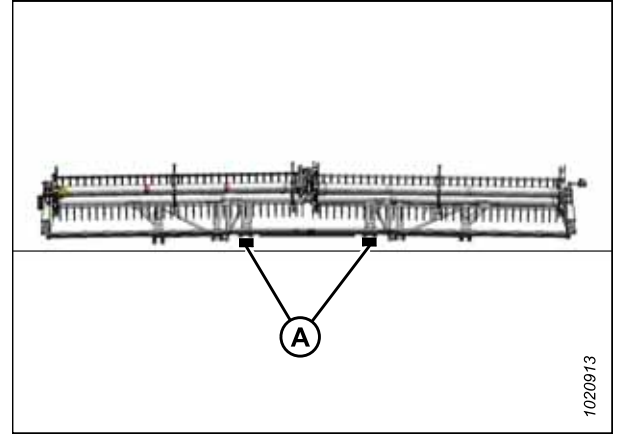


Figure 4.269: FlexDraper® Block Locations – Double Reel

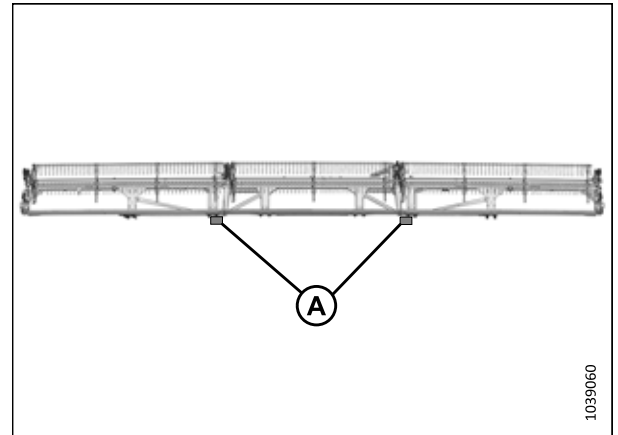


Figure 4.270: FlexDraper® Block Locations – Triple Reel

5. Lower the reel fully and continue holding the control button down to phase the cylinders.
6. Shut down the engine, and remove the key from the ignition.
7. Adjust the clearance at the outboard ends of the reel as follows:
  - a. Loosen bolt (A) on the outer arm cylinder.
  - b. Adjust cylinder rod (B) as needed:
    - To increase the clearance between the reel fingers and the cutterbar, turn cylinder rod (B) out of the clevis.
    - To decrease the clearance between the reel fingers and the cutterbar, turn cylinder rod (B) into the clevis.
  - c. Tighten bolt (A).
8. Repeat Step 7, page 725 on the opposite side of the header.

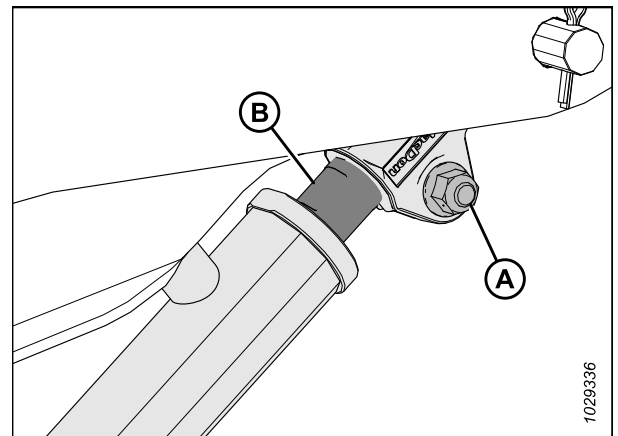


Figure 4.271: Outside Arm Cylinder

## MAINTENANCE AND SERVICING

9. Loosen bolts (A) on both center arm cylinders.

10. Adjust the clearance as follows:

**IMPORTANT:**

Adjust both cylinder rods equally.

- To increase the clearance between the reel fingers and the cutterbar, turn cylinder rods (D) out of the clevis.
- To decrease the clearance between the reel fingers and the cutterbar, turn cylinder rods (D) into the clevis.

11. Ensure that measurement (B) is identical on both cylinders.

**NOTE:**

Measurement (B) runs from the center of mounting pins (C) to the tops of the notches in cylinder rods (D).

12. Ensure that both mounting pins (C) **CANNOT** be rotated by hand. If one of the mounting pins can be rotated, adjust cylinder rods (D) as needed:

- Turn the cylinder rod out of the clevis to increase the load on the cylinder rod.
- Turn the cylinder rod into the clevis to decrease the load on the cylinder rod.

13. Tighten bolts (A).

14. **Triple-reel headers:** Repeat Step 9, page 726 to Step 13, page 726 to set the reel-to-cutterbar clearance on the other center reel arm.

15. Start the engine.

16. Raise the reel fully.

17. Lower the reel fully and continue holding the control button down to phase the cylinders.

18. Shut down the engine, and remove the key from the ignition.

19. Check the reel-to-cutterbar clearance measurements again. If necessary, repeat the adjustment procedures.

20. Move the reel back to ensure that the reel fingers do not contact the deflector shields.

21. If the reel fingers contact the deflector shields, adjust the reel upward to maintain the clearance at all reel fore-aft positions. If contact still occurs after the reel is adjusted, trim the fingers as needed.

22. Periodically check for evidence of contact during operation. Adjust the reel-to-cutterbar clearance as needed.

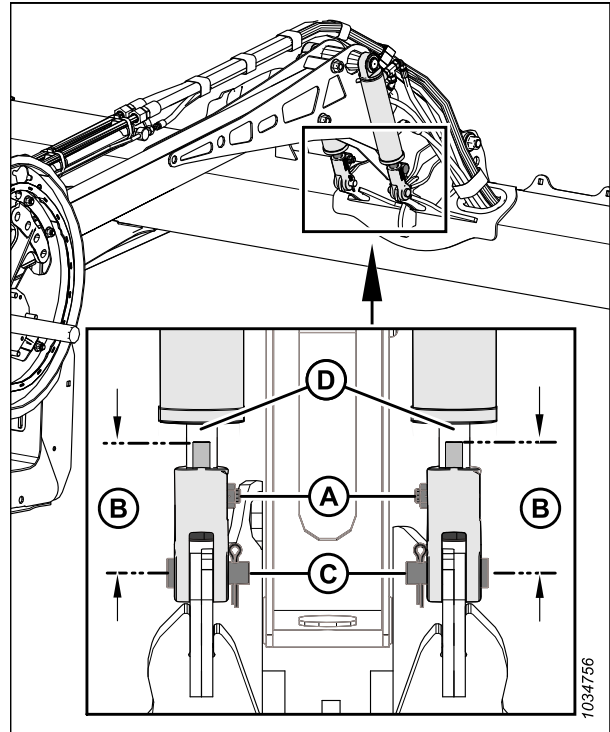


Figure 4.272: Center Arm Cylinders



### 4.13.2 Reel Frown

The reel must be set up to frown (providing more clearance at the center of the reel than at the ends) to compensate for reel flexing.

#### Adjusting Reel Shape

The reel tine tubes must be set up to frown (provide more clearance at the center of the reel than at the ends) to compensate for reel flexing.

#### DANGER

To prevent bodily injury or death from the unexpected start-up of the machine, always stop the engine and remove the key from the ignition before making adjustments to the machine.

1. Position the reel over the cutterbar (between 4 and 5 on fore-aft position indicator [A]) to provide adequate clearance at all reel fore-aft positions. Bracket (B) is the position marker.
2. Shut down the engine, and remove the key from the ignition.
3. Record the measurement at each reel disc location for each reel tube.

#### NOTE:

Measure the frown profile before disassembling the reel for servicing so the profile can be maintained during reassembly.

4. Start with the reel disc closest to the center of the header and proceed outward towards the ends, adjusting the header profile as follows:
  - a. Remove bolts (A).
  - b. Loosen bolt (B) and adjust arm (C) until the desired measurement is obtained between the reel tube and cutterbar.

#### NOTE:

Allow the reel tubes to curve naturally and position the hardware accordingly.

- c. Reinstall bolts (A) in the aligned holes and tighten them.

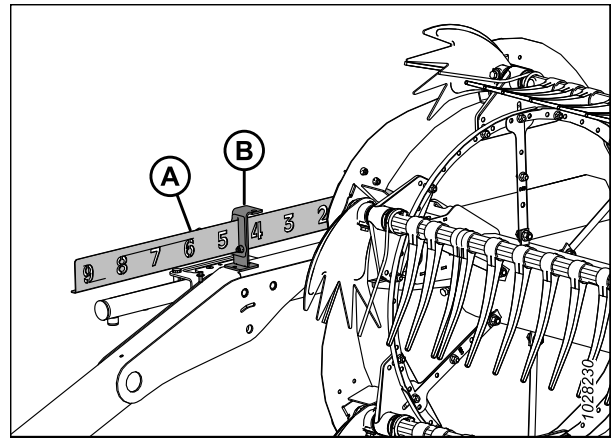


Figure 4.273: Fore-Aft Position Indicator

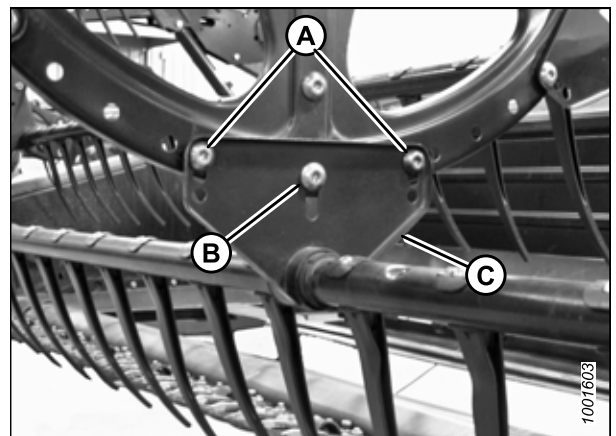


Figure 4.274: Center Reel Disc

### 4.13.3 Centering Reel

The reel needs to be centered on the header to avoid any contact with the end panels.

#### DANGER

To prevent bodily injury or death from the unexpected startup of the machine, always stop the engine and remove the key before adjusting the machine.

**⚠ DANGER**

Ensure that all bystanders have cleared the area.

1. Lower the reel fully.
2. Lower the header fully.
3. Shut down the engine, and remove the key from the ignition.
4. Measure clearance (A) at locations (B) between the reel tine tube and the endsheet at both ends of the header. The clearances should be the same if the reel is centered.

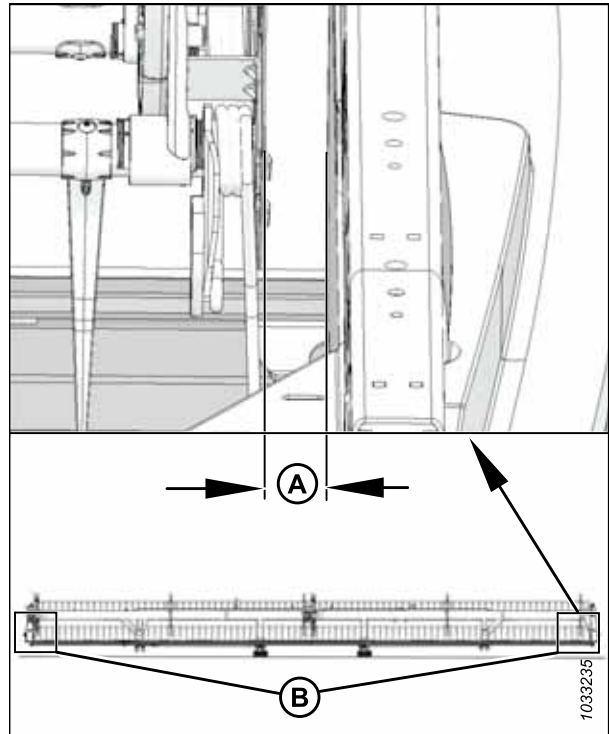


Figure 4.275: Clearance between Reel and Endsheet

5. Loosen bolt (A) on brace (B) on the center support arm.
6. Move the forward end of reel support arm (C) laterally as needed to center the reel.
7. Torque bolt (A) to 457 Nm (337 lbf-ft).

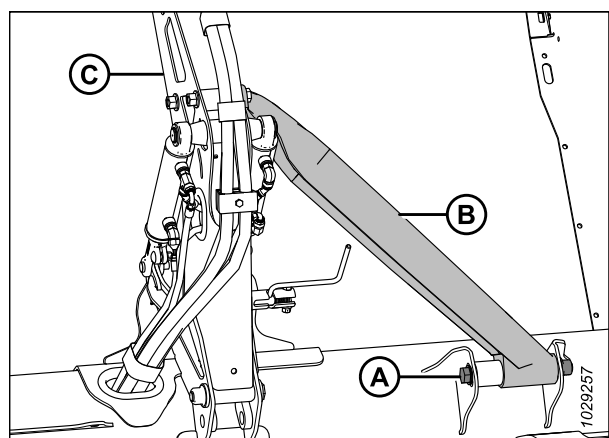


Figure 4.276: Center Support Arm

### 4.13.4 Reel Fingers

If a reel finger is damaged or worn, it will need to be removed so it can be replaced. Reel fingers are either steel or plastic.

**IMPORTANT:**

Keep the reel fingers in good condition and straighten or replace them as necessary.

#### *Removing Steel Reel Fingers*

Damaged steel fingers will need to be cut off of the reel tine tube.

**⚠ DANGER**

To prevent injury or death from the unexpected start-up of the machine, always stop the engine and remove the key from the ignition before leaving the operator's seat for any reason.

**⚠ DANGER**

Ensure that all bystanders have cleared the area.

**⚠ WARNING**

To prevent bodily injury from the fall of a raised reel, always engage the reel safety props before going under the raised reel for any reason.

**IMPORTANT:**

Support the tine tube at all times to avoid damaging it and other components.

1. Lower the header fully.
2. Raise the reel fully.
3. Shut down the engine, and remove the key from the ignition.
4. Engage the reel safety props. For instructions, refer to *Engaging Reel Safety Props, page 39*.
5. Remove the tine tube bushings from the applicable tine tube at the center and left reel discs. For instructions, refer to *Removing Bushings from Reels, page 732*.
6. Attach tine tube arms (B) to the reel disc at original attachment locations (A).
7. Cut the damaged finger to remove it from the tine tube.
8. Remove the bolts from the fingers that were beside the original finger and slide the fingers over to replace the finger that was cut off. Remove tine tube arms [B] from the tine tubes as necessary.

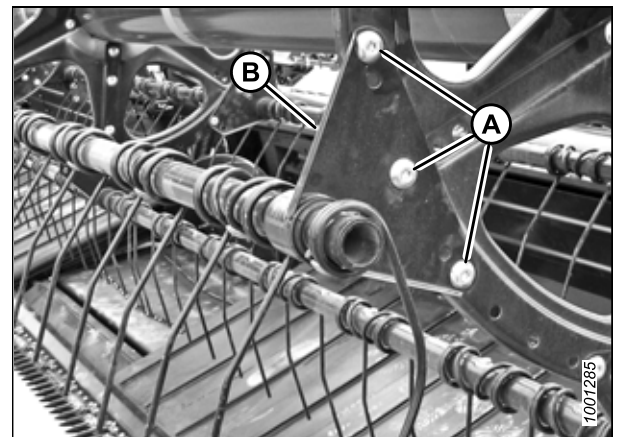


Figure 4.277: Tine Tube Arm

### *Installing Steel Reel Fingers*

Once the old steel finger has been removed, a new finger can be pushed onto the tine tube.

**NOTE:**

This procedure assumes a finger has been removed from the machine. For instructions about removing fingers, refer to [Removing Steel Reel Fingers, page 729](#).

**⚠ DANGER**

To prevent injury or death from the unexpected start-up of the machine, always stop the engine and remove the key from the ignition before leaving the operator's seat for any reason.

**⚠ WARNING**

To prevent bodily injury from the fall of a raised reel, always engage the reel safety props before going under the raised reel for any reason.

**IMPORTANT:**

Support the tine tube at all times to prevent damage to the tube and other components.

1. Slide the new finger and tine tube arm (A) onto the end of the tube.
2. Install the tine tube bushings. For instructions, refer to [Installing Bushings onto Reels, page 735](#).
3. Attach the fingers to the tine tube with bolts and nuts (B).

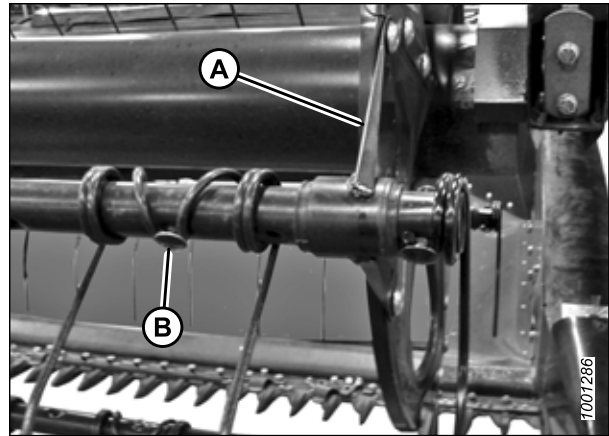


Figure 4.278: Tine Tube

### *Removing Plastic Reel Fingers*

Plastic reel fingers are secured to the tine tube with a single Torx® screw.

**⚠ DANGER**

To prevent bodily injury or death from the unexpected start-up of the machine, always stop the engine and remove the key from the ignition before making adjustments to the machine.

**⚠ DANGER**

Ensure that all bystanders have cleared the area.

**⚠ WARNING**

To prevent bodily injury from the fall of a raised reel, always engage the reel safety props before going under the raised reel for any reason.

## MAINTENANCE AND SERVICING

1. Lower the header fully.
2. Raise the reel fully.
3. Shut down the engine, and remove the key from the ignition.
4. Engage the reel safety props. For instructions, refer to *Engaging Reel Safety Props*, page 39.
5. Remove screw (A) using a Torx Plus® 27 IP socket wrench.

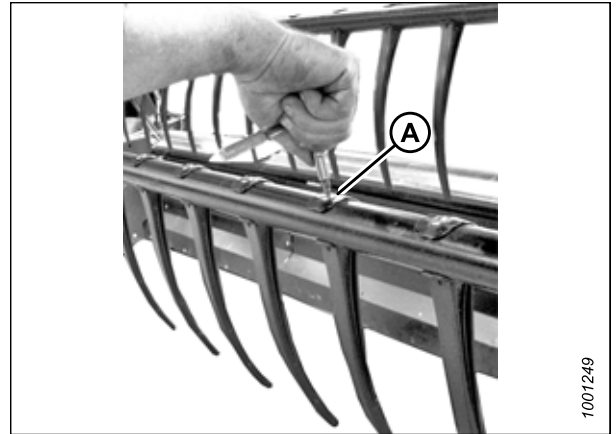


Figure 4.279: Removing Plastic Finger

6. Push the clip at the top of the finger back toward the reel tube as shown and remove the finger from the tube.

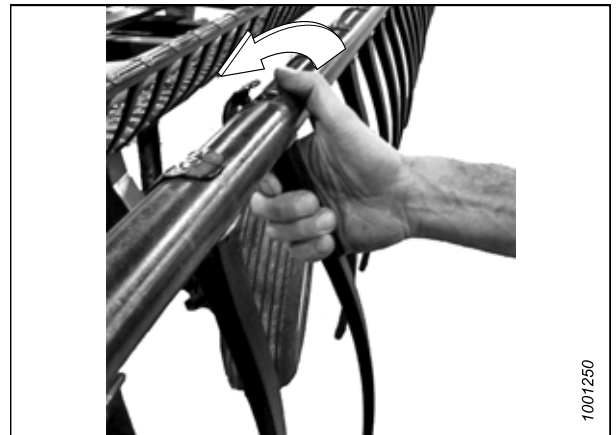


Figure 4.280: Removing Plastic Finger

### *Installing Plastic Reel Fingers*

Once the old plastic reel finger has been removed, the new one can be installed.

#### **DANGER**

To prevent injury or death from the unexpected start-up of the machine, always stop the engine and remove the key from the ignition before leaving the operator's seat for any reason.

#### **WARNING**

To prevent bodily injury from the fall of a raised reel, always engage the reel safety props before going under the raised reel for any reason.

**NOTE:**

This procedure assumes a finger has been removed from the machine. For information about removing fingers, refer to *Removing Plastic Reel Fingers*, page 730.

1. Position the new finger on the rear of the tine tube. Engage the lug at the bottom of the finger in the lower hole in the tine tube.
2. Lift the top flange and rotate the finger as shown until the lug in the top of the finger engages the upper hole in the tine tube.



Figure 4.281: Installing Plastic Finger

3. Install screw (A) using a Torx Plus® 27 IP socket wrench and torque it to 8.5–9.0 Nm (6.3–6.6 lbf·ft [75–80 lbf·in]).

**IMPORTANT:**

Do **NOT** apply force to the finger before tightening the mounting screw. Applying force without tightening the mounting screw will break the finger or shear the locating pins.

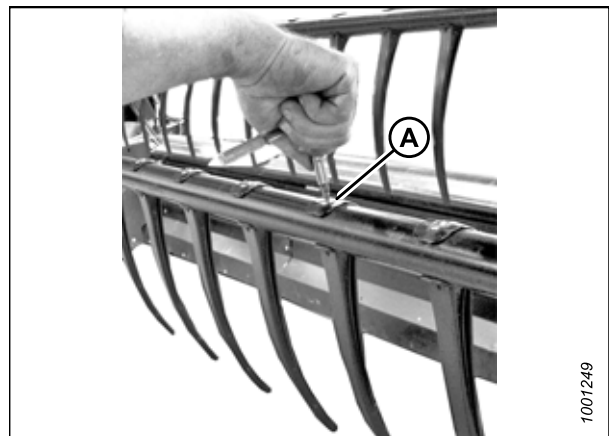


Figure 4.282: Installing Plastic Finger

### 4.13.5 Tine Tube Bushings

The reel tine tube rests in a tine tube bushing, which is secured to the reel disc. If a tine tube bushing is damaged or worn, it will need to be replaced.

#### *Removing Bushings from Reels*

The bushing clamps securing the tine tube to the bushing will need to be released so that the bushing halves can be removed.

**⚠ DANGER**

To prevent bodily injury or death from the unexpected start-up of the machine, always stop the engine and remove the key from the ignition before making adjustments to the machine.

**⚠ DANGER**

Ensure that all bystanders have cleared the area.

**⚠ WARNING**

To prevent bodily injury from the fall of a raised reel, always engage the reel safety props before going under the raised reel for any reason.

**IMPORTANT:**

Support the tine tube at all times to prevent damage to the tube and other components.

1. Lower the header fully.
2. Raise the reel fully.
3. Shut down the engine, and remove the key from the ignition.
4. Engage the reel safety props. For instructions, refer to *Engaging Reel Safety Props, page 39*.

**NOTE:**

If you are only replacing the cam end bushing, proceed to Step 10, page 734.

**Center disc and tail end bushings**

5. Remove the reel endshields and endshield support (C) from the tail end of the reel at the applicable tine tube location.

**NOTE:**

There are no endshields on the center disc.

6. Remove bolts (A) securing tine tube arm (B) to the disc.

**IMPORTANT:**

Note the hole locations in the arm and disc and ensure bolts (A) are reinstalled at the original locations.

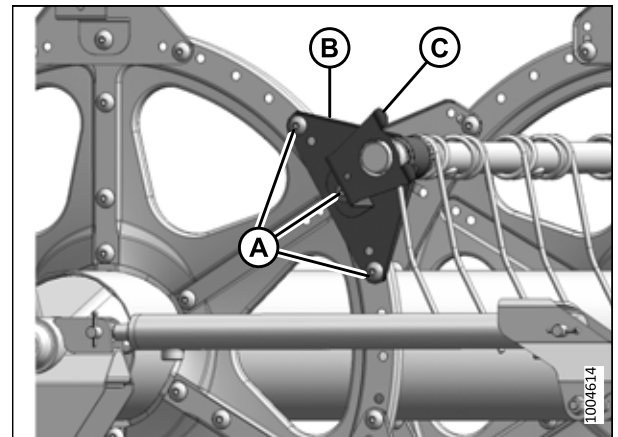


Figure 4.283: Tail End

7. Release bushing clamps (A) using a small screwdriver to separate the serrations. Pull the clamp off the tine tube.

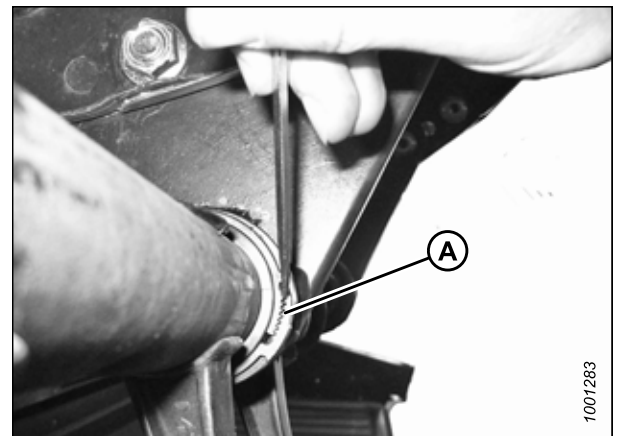


Figure 4.284: Bushing Clamp



## MAINTENANCE AND SERVICING

8. Rotate tine tube arm (A) until it is clear of the disc, and then slide the arm inboard off of bushing (B).
9. Remove bushing halves (B). If necessary, remove the next finger, so that the arm can slide off of the bushing. Refer to the following procedures as needed:
  - *Removing Plastic Reel Fingers, page 730*
  - *Removing Steel Reel Fingers, page 729*

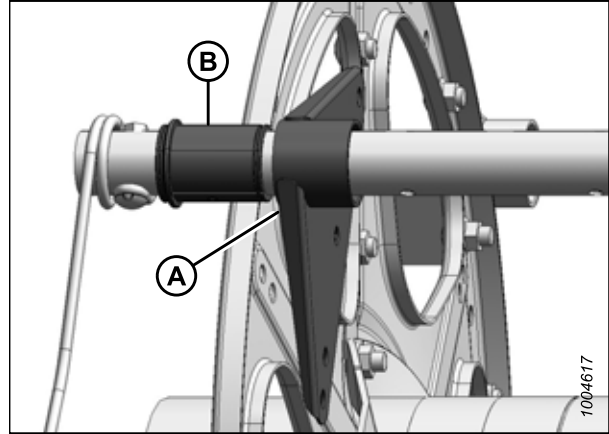


Figure 4.285: Bushing

### Cam end bushings

10. Remove the endshields and endshield support (A) from the applicable tine tube location on the cam end.

**NOTE:**

Removing the cam end bushings requires moving the tine tube through the disc arms to expose the bushing.

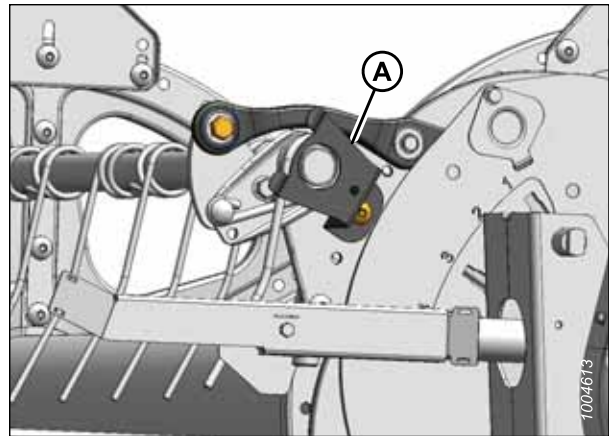


Figure 4.286: Cam End

11. Remove the reel endshields and endshield support (C) from the tail end of the reel at the applicable tine tube location.

**NOTE:**

There are no endshields on the center disc.

12. Remove bolts (A) securing tine tube arms (B) to the tail and the center discs.

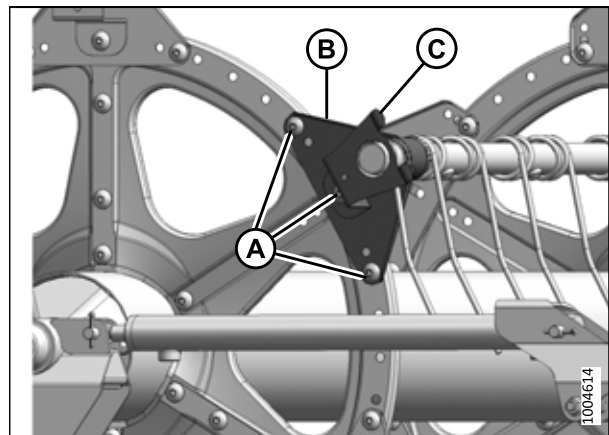


Figure 4.287: Tail End



### Installing Bushings onto Reels

Once the old tine tube bushing halves have been removed, the new ones can be installed.

**NOTE:**

This procedure assumes the steps for *Removing Bushings from Reels*, page 732 have been completed.

**⚠ DANGER**

To prevent bodily injury or death from the unexpected start-up of the machine, always stop the engine and remove the key from the ignition before making adjustments to the machine.

**⚠ WARNING**

To prevent bodily injury from the fall of a raised reel, always engage the reel safety props before going under the raised reel for any reason.

**IMPORTANT:**

Support the tine tube at all times to prevent damage to the tube or other components.

1. Use a pair of modified channel lock pliers (A) to install bushing clamps (C). Secure the pliers in a vise and grind notch (B) into the end of each arm to fit the clamp as shown.

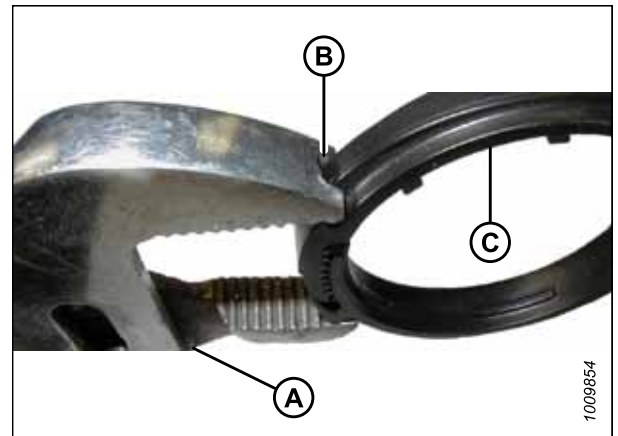


Figure 4.288: Modified Channel Lock Pliers

### Cam end bushings

2. Position bushing halves (B) on tine tube (A) with the flangeless end adjacent to the tine tube arm, and position the lug in each bushing half into the hole in the tine tube.
3. Slide tine tube (A) toward the tail end of the reel to insert bushing (B) into the tine tube arm. If the tine tube supports are installed, ensure that the bushings at those locations slide into the support.
4. Reinstall the previously removed fingers. Refer to the following procedures as needed:
  - *Installing Plastic Reel Fingers*, page 731
  - *Installing Steel Reel Fingers*, page 730

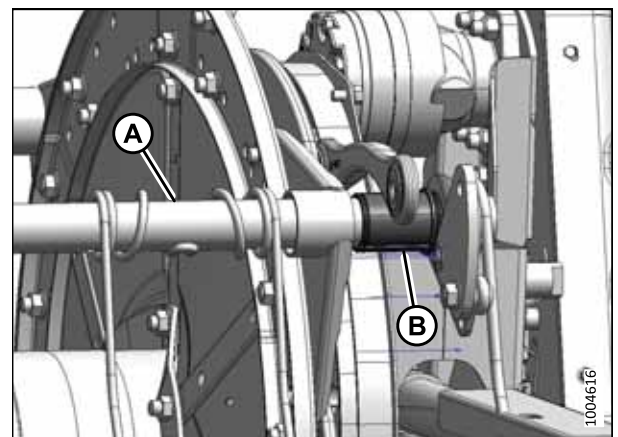


Figure 4.289: Cam End

## MAINTENANCE AND SERVICING

5. Install bushing clamp (A) onto the tine tube adjacent to the flangeless end of bushing (B).
6. Position clamp (A) on bushing (B) so that the edges of the clamp and the bushing are flush when the clamp fits into the groove on the bushing and when the lock tabs are engaged.

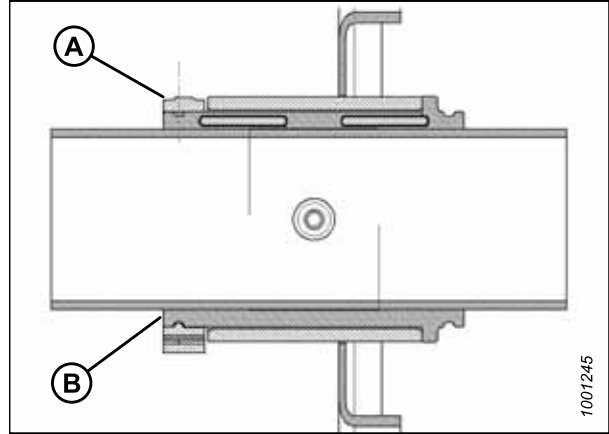


Figure 4.290: Bushing

7. Tighten clamp (A) using modified channel lock pliers (B) until finger pressure **CANNOT** move the clamp.

**IMPORTANT:**

Overtightening the clamp may result in breakage.

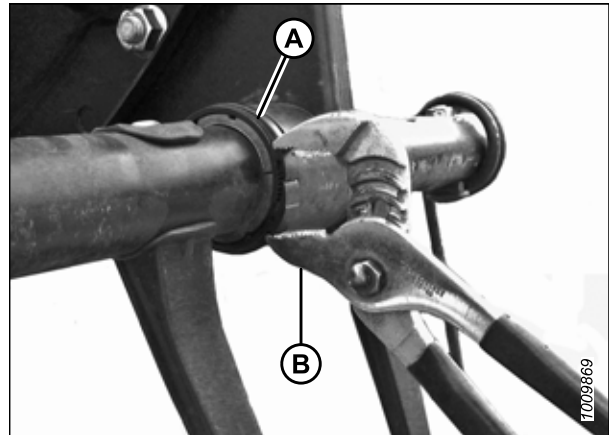


Figure 4.291: Installing Clamp

8. Line up tine tube (B) with the cam arm and install bolt (A). Torque the bolt to 165 Nm (120 lbf-ft).

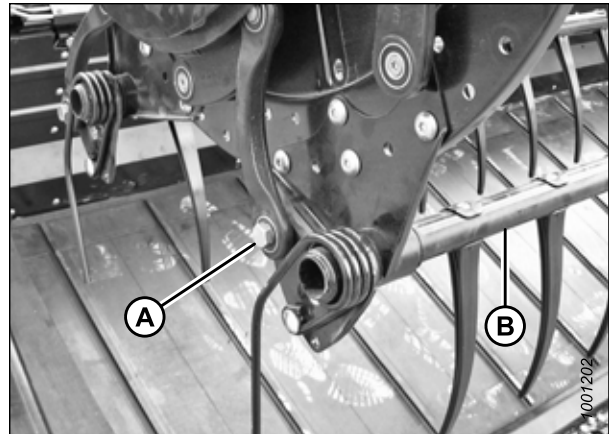


Figure 4.292: Cam End

9. Install bolts (A) securing tine tube arm (B) to the center disc.
10. Install tine tube arm (B) and endshield support (C) onto the tail end of the reel at the applicable tine tube location. Secure the support with bolts (A).

**NOTE:**

There are no endshields on the center discs.

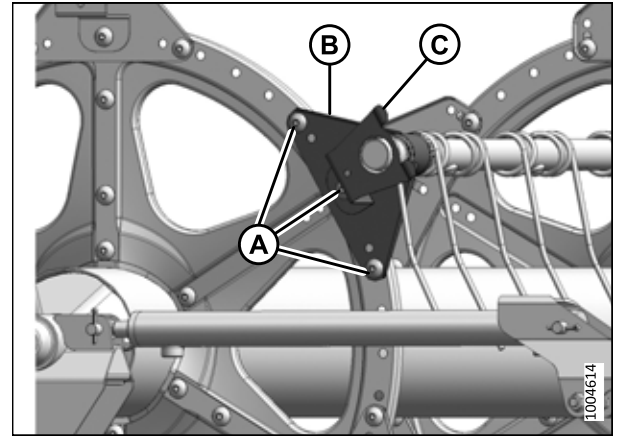


Figure 4.293: Tail End

11. Install endshield support (A) at the applicable tine tube location at the cam end of the reel.
12. Reinstall the reel endshields. For instructions, refer to [4.13.6 Reel Endshields, page 738](#).

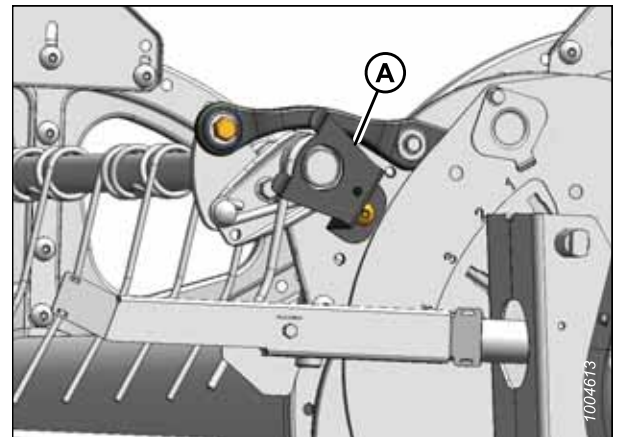


Figure 4.294: Cam End

**Center disc and tail end bushings**

13. Position bushing halves (B) on tine tube (A) with the flangeless end adjacent to the tine tube arm, and position the lug in each bushing half into the hole in the tine tube.
14. Slide tine tube (A) onto bushing (B). Position the tine tube against the disc at its original location.
15. Reinstall the previously removed fingers. For instructions, refer to:
  - [Installing Plastic Reel Fingers, page 731](#)
  - [Installing Steel Reel Fingers, page 730](#)

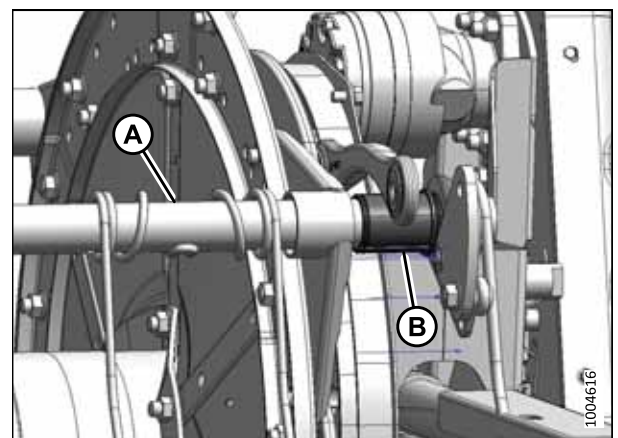


Figure 4.295: Cam End

16. Install bushing clamp (A) onto the tine tube adjacent to the flangeless end of bushing (B).
17. Position clamp (A) on bushing (B) so that the edges of the clamp and the bushing are flush when the clamp fits into the groove on the bushing and when the lock tabs are engaged.

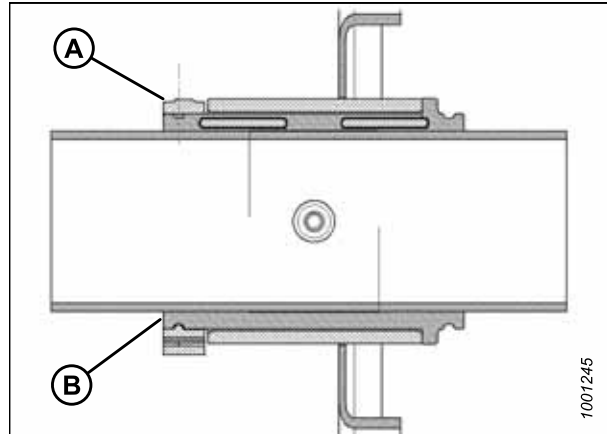


Figure 4.296: Bushing

18. Tighten clamp (A) using modified channel lock pliers (B) until finger pressure **CANNOT** move the clamp.

**IMPORTANT:**

Overtightening the clamp may result in breakage.

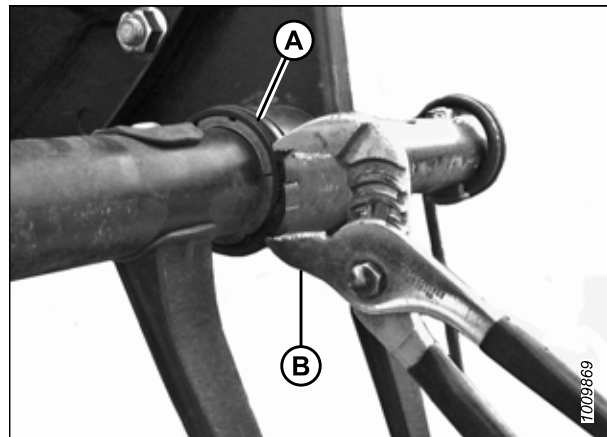


Figure 4.297: Installing Clamp

19. Install bolts (A) securing tine tube arm (B) to the center disc.
20. Install tine tube arm (B) and endshield support (C) onto the tail end of the reel at the applicable tine tube location. Secure the support with bolts (A).

**NOTE:**

There are no endshields on the center discs.

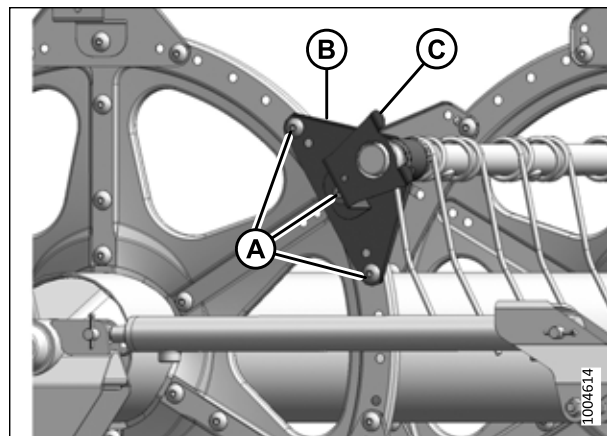


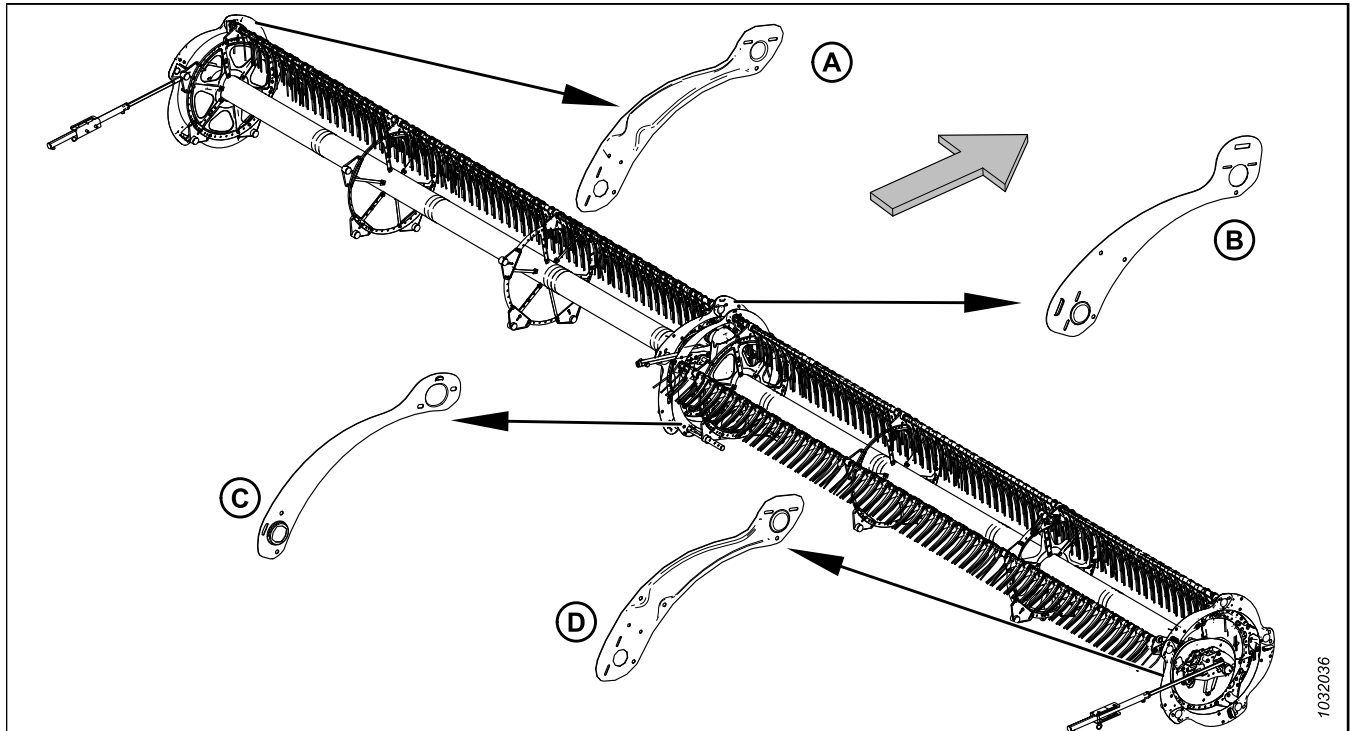
Figure 4.298: Tail End

### 4.13.6 Reel Endshields

The reel endshields and the supports do not require regular maintenance, but they should be checked periodically for damage and loose or missing fasteners. Slightly dented or deformed endshields and supports are repairable, but it is necessary to replace severely damaged components.

## MAINTENANCE AND SERVICING

There are four kinds of reel endshields. Ensure that you are installing the correct reel endshield to the proper location as shown in Figure 4.299 *Reel Endshields*, page 739.



**Figure 4.299: Reel Endshields**

A - Tail End, Outboard (MD #311695)  
C - Tail End, Inboard (MD #311795)

B - Cam End, Inboard (MD #273823)  
D - Cam End, Outboard (MD #311694)

### NOTE:

The arrow in the illustration points to the front of the machine.

### *Replacing Reel Endshields at Outboard Cam End*

The procedure for replacing reel endshields is applicable to the outboard cam end, except where noted.

### **DANGER**

To prevent injury or death from the unexpected start-up of the machine, always stop the engine and remove the key from the ignition before leaving the operator's seat for any reason.

### **DANGER**

Ensure that all bystanders have cleared the area.

### NOTE:

The arrows in the illustrations in this procedure indicate the front of the header.

### NOTE:

Retain all of the removed parts unless directed to do otherwise.

1. Lower the header and the reel fully.
2. Shut down the engine, and remove the key from the ignition.

## MAINTENANCE AND SERVICING

3. Rotate the reel manually until reel endshield requiring replacement (A) is accessible.
4. Remove three bolts (B).

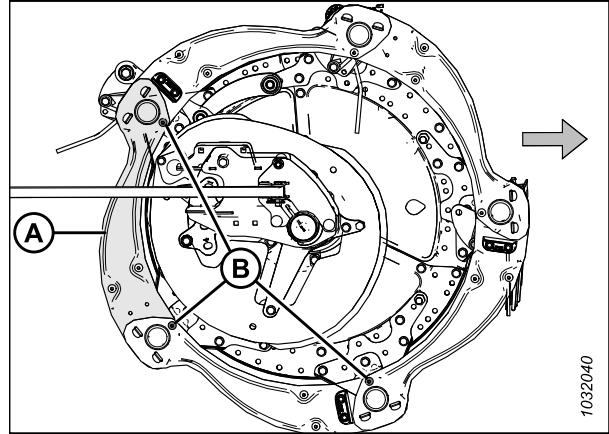


Figure 4.300: Reel Endshields – Outboard Cam End

5. Remove two screws and nuts (A). Remove the outboard cam deflector.
6. Lift the end of reel endshield (B) off of support (C).

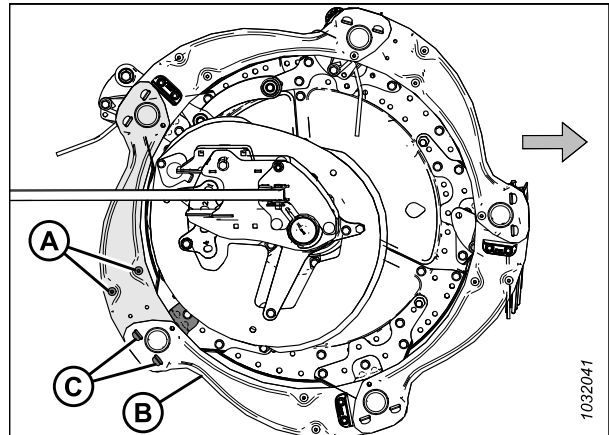


Figure 4.301: Reel Endshields – Outboard Cam End

7. Remove the reel endshield from supports (A).

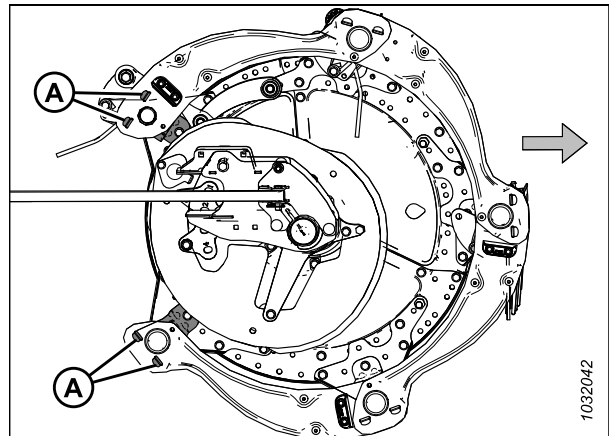


Figure 4.302: Reel Endshield Removed – Outboard Cam End



## MAINTENANCE AND SERVICING

8. Slightly lift the end of old reel endshield (A) off of support (B).
9. Position new reel endshield (C) onto support (B) under old reel endshield (A).
10. Position the other end of new reel endshield (C) onto other support (D) over old reel endshield (E).
11. Reinstall three bolts (F).
12. Reinstall two screws (G), the outboard cam deflector, and the nuts (removed in Step 5, [page 740](#)) on the new reel endshield.
13. Tighten all of the installed hardware.

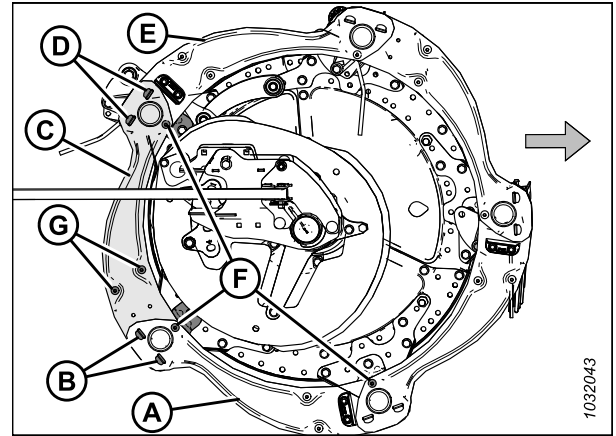


Figure 4.303: Reel Endshields – Outboard Cam End

### *Replacing Reel Endshields at Inboard Cam End*

The procedure for replacing reel endshields is applicable to the inboard cam end.

#### **DANGER**

To prevent injury or death from the unexpected start-up of the machine, always stop the engine and remove the key from the ignition before leaving the operator's seat for any reason.

#### **DANGER**

Ensure that all bystanders have cleared the area.

The endshields are different for the inboard and outboard cam ends. For reference, refer to Figure 4.299, [page 739](#).

#### **NOTE:**

The arrows in the following illustrations point to the front of the machine.

1. Lower the reel fully.
2. Lower the header fully.
3. Shut down the engine, and remove the key from the ignition.
4. Rotate the reel manually until reel endshield requiring replacement (A) is accessible.
5. Remove three bolts (B).

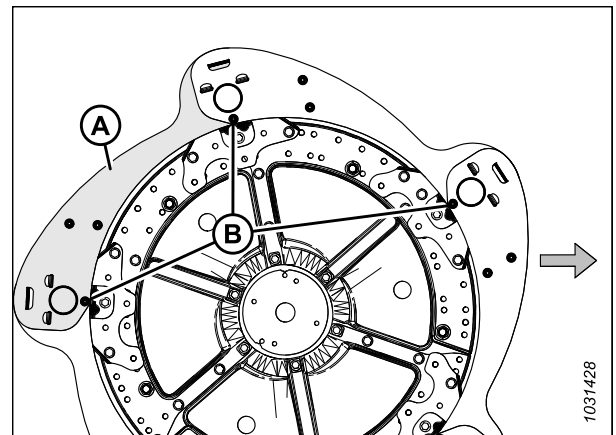


Figure 4.304: Reel Endshields – Inboard Cam End

## MAINTENANCE AND SERVICING

6. Remove and retain two screws (A), the cam deflector, and the nuts from the reel endshield.
7. Lift the end of reel endshield (B) off support (C).

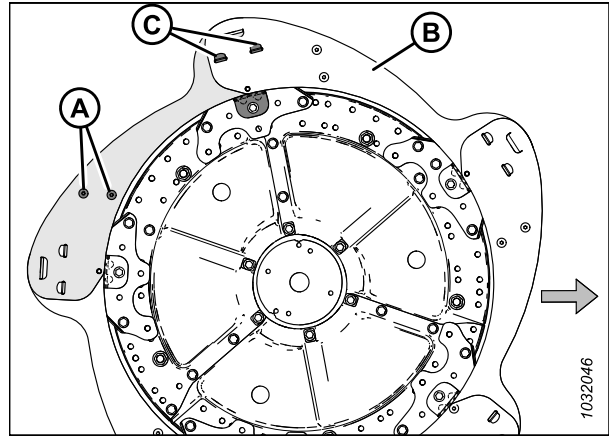


Figure 4.305: Reel Endshields – Inboard Cam End

8. Remove the reel endshield from supports (A).

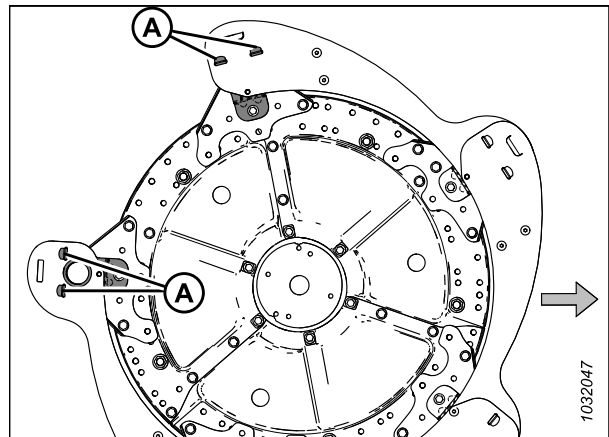


Figure 4.306: Reel Endshield Removed – Inboard Cam End

9. Slightly lift the end of old reel endshield (A) off of support (B).
10. Position new reel endshield (C) onto support (B) under old reel endshield (A).
11. Position the other end of new reel endshield (C) onto other support (D) over old reel endshield (E).
12. Reinstall three bolts (F).
13. Reinstall two screws (G), the cam deflector, and the nuts (removed in Step 6, page 742) on the new reel endshield.
14. Tighten all of the installed hardware.

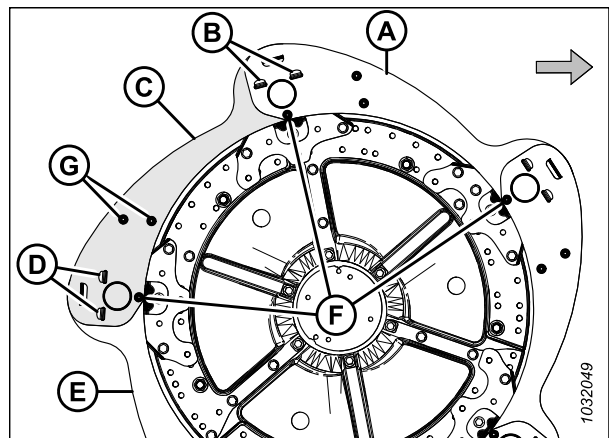


Figure 4.307: Reel Endshields – Inboard Cam End



*Replacing Reel Endshields at Outboard Tail End*

If the reel endshield is damaged, it will need to be replaced.

**⚠ DANGER**

To prevent injury or death from the unexpected start-up of the machine, always stop the engine and remove the key from the ignition before leaving the operator's seat for any reason.

**⚠ DANGER**

Ensure that all bystanders have cleared the area.

1. Lower the reel fully.
2. Lower the header fully.
3. Shut down the engine, and remove the key from the ignition.
4. Rotate the reel manually until reel endshield requiring replacement (A) is accessible.
5. Remove three bolts (B).

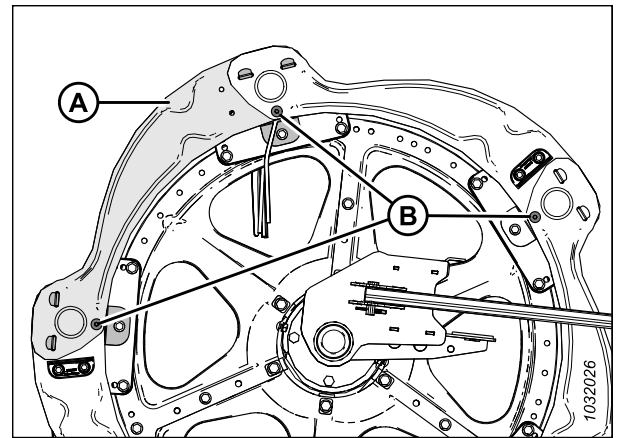


Figure 4.308: Reel Endshields – Outboard Tail End

6. Lift the end of reel endshield (A) off support (B).

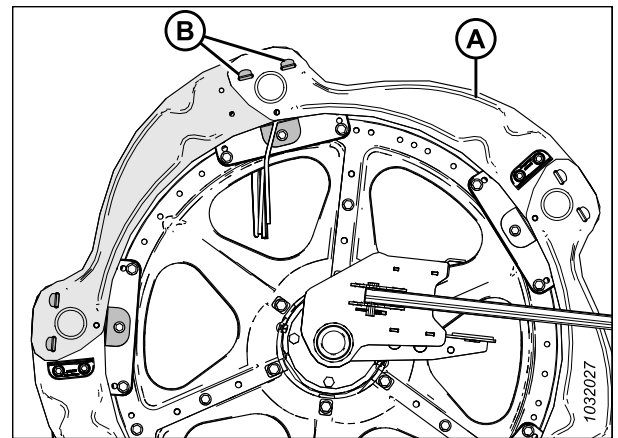


Figure 4.309: Reel Endshields – Outboard Tail End

7. Remove the reel endshield from supports (A).
8. Remove the reel paddle, if it is installed on the reel endshield.

**NOTE:**

Reel end paddles (B) are installed alternately on the reel endshields.

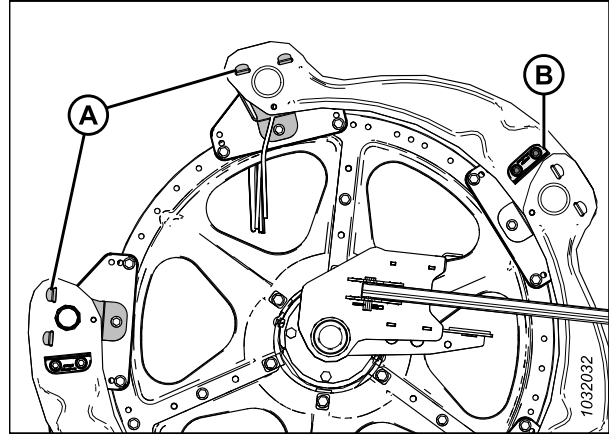


Figure 4.310: Reel Endshield Removed – Outboard Tail End

9. Slightly lift the end of reel endshield (A) off of support (B).
10. Position new reel endshield (C) onto support (B) under old reel endshield (A).
11. Position the other end of new reel endshield (C) on other support (E) over the old reel endshield.
12. Reinstall three bolts (D).
13. Reinstall the paddle (removed in Step 8, page 744) onto the new reel endshield, if it was previously installed.
14. Tighten all of the installed hardware.

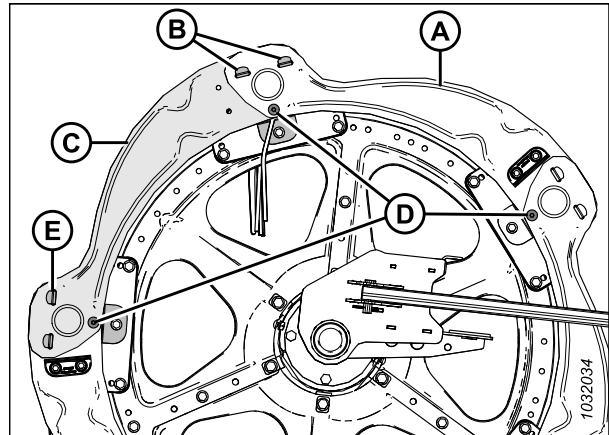


Figure 4.311: Reel Endshields – Outboard Tail End

*Replacing Reel Endshields at Inboard Tail End*

The reel endshields need to be replaced if they are damaged.

**⚠ DANGER**

To prevent injury or death from the unexpected start-up of the machine, always stop the engine and remove the key from the ignition before leaving the operator's seat for any reason.

**⚠ DANGER**

Ensure that all bystanders have cleared the area.

**NOTE:**

Retain all removed parts, unless directed to do otherwise.

1. Lower the reel fully.
2. Lower the header fully.
3. Shut down the engine, and remove the key from the ignition.

## MAINTENANCE AND SERVICING

4. Rotate the reel manually until reel endshield requiring replacement (A) is accessible.
5. Remove six M10 screws and nuts (B).

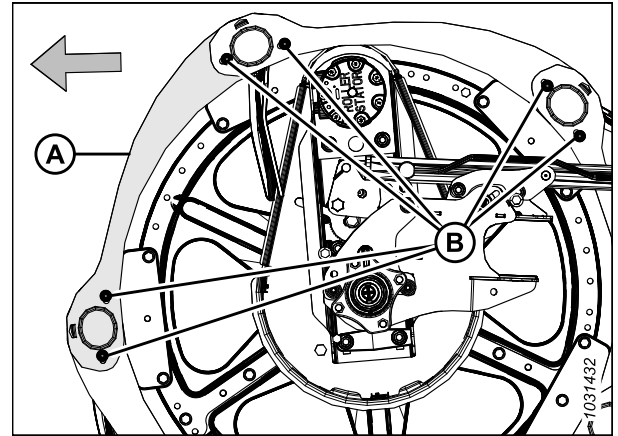


Figure 4.312: Reel Endshields – Inboard Tail End

6. Lift other endshield (A) to disengage the tab from endshield (B).
7. Lift the end of reel endshield (B) off endshield (C), and rotate endshield (B) downward.

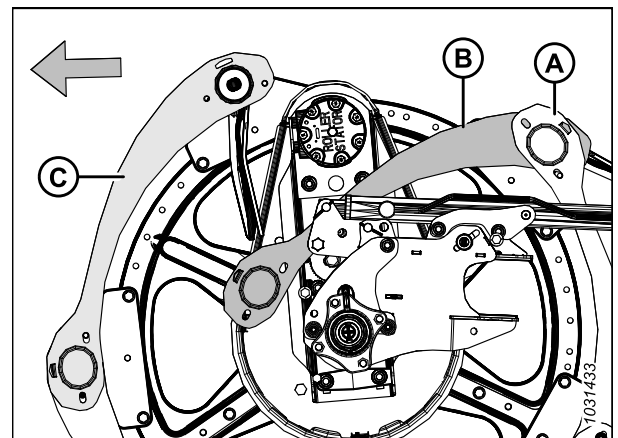


Figure 4.313: Reel Endshields – Inboard Tail End

8. Remove M10 bolt (A), nut (B), and end finger retainer (C) from the tine tube securing the bushing and tail end finger.
9. Remove endshield bushing (D).
10. Remove and discard damaged reel endshield (E).

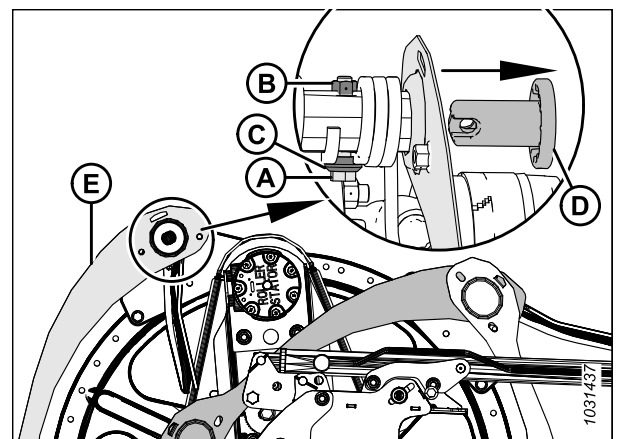


Figure 4.314: Reel Endshields – Inboard Tail End

## MAINTENANCE AND SERVICING

11. Position new reel endshield (A) as shown. Insert the endshield tab into neighboring endshield (B).
12. Position the other end of new endshield (A) on the tine tube. Secure the endshield with bushing (C).

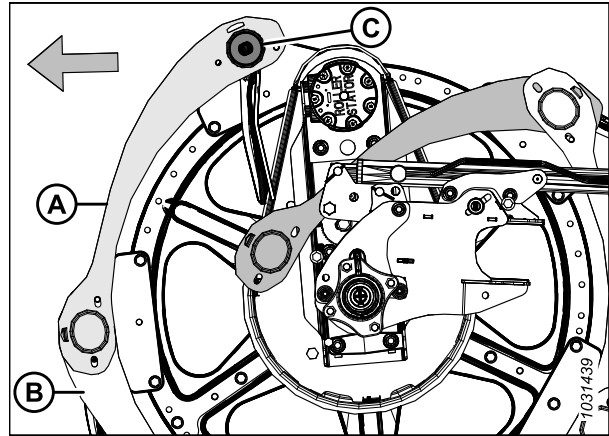


Figure 4.315: Reel Endshields – Inboard Tail End

13. Position tail end finger (A) as shown.
14. Secure tail end finger (A) and the bushing (installed in Step 12, page 746) with M10 bolt (B), end finger retainer (C), and nut (D).

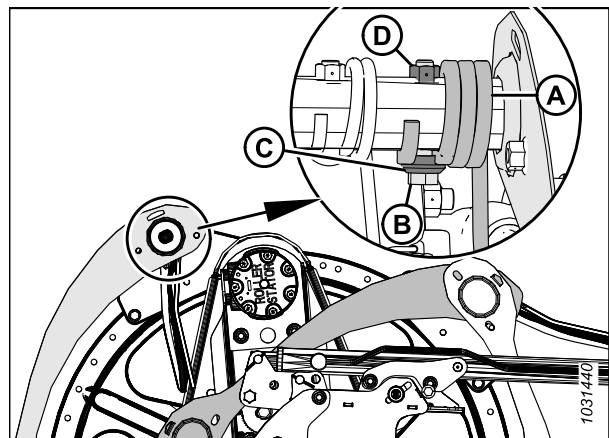


Figure 4.316: Reel Endshields – Inboard Tail End

15. Rotate reel endshield (A) upward. Engage tabs (B) on both ends.
16. Secure the reel endshields using six M10 screws and nuts (C).
17. Torque nuts (C) to 35 Nm (26 lbf·ft).

### IMPORTANT:

Do **NOT** overtighten the nuts.

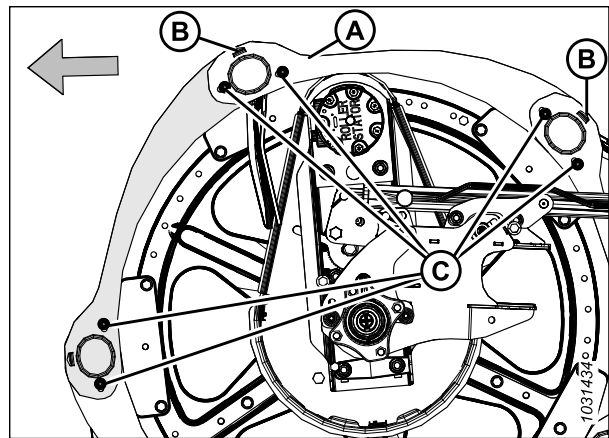


Figure 4.317: Reel Endshields – Inboard Tail End

### Replacing Reel Endshield Supports

The reel endshield supports need to be replaced if they are damaged.

#### DANGER

To prevent injury or death from the unexpected start-up of the machine, always stop the engine and remove the key from the ignition before leaving the operator's seat for any reason.

#### DANGER

Ensure that all bystanders have cleared the area.

#### NOTE:

All of the illustrations shown show the outboard cam end.

1. Lower the reel fully.
2. Lower the header fully.
3. Shut down the engine, and remove the key from the ignition.
4. Rotate the reel manually until the reel endshield support requiring replacement is accessible.
5. Remove bolt (B) securing the reel endshields to support (A).
6. Remove bolts (C) from support (A) and from the two adjacent supports.

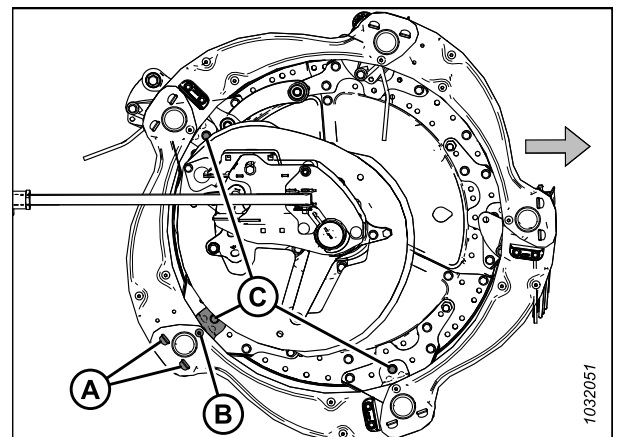


Figure 4.318: Reel Endshield Supports

7. Move reel endshields (A) and support (B) away from the tine tube. Remove the support from the endshields.
8. Insert the tabs of new support (B) into the slots in reel endshields (A). Ensure that the tabs engage both reel endshields.

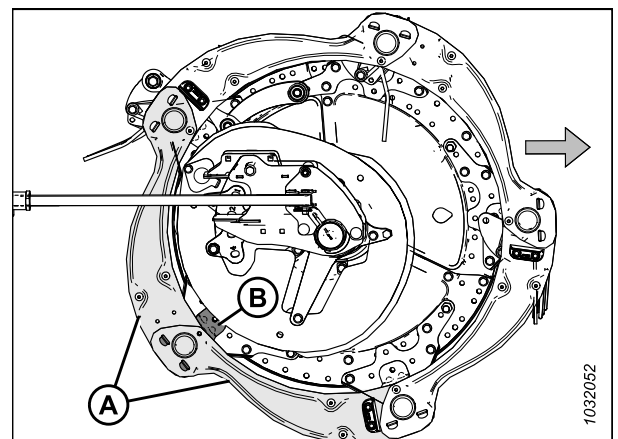


Figure 4.319: Reel Endshield Supports

## MAINTENANCE AND SERVICING

9. Secure support (A) to the disc sector with bolt and nut (B). Do **NOT** tighten the hardware yet.
10. Secure reel endshields (C) to support (A) with bolt and nut (D). Do **NOT** tighten the hardware yet.
11. Reattach the other supports with bolts and nuts (E).
12. Ensure that there is adequate clearance between the tine tube and the reel endshield support.
13. Torque the nuts to 27 Nm (20 lbf-ft [239 lbf-in]).

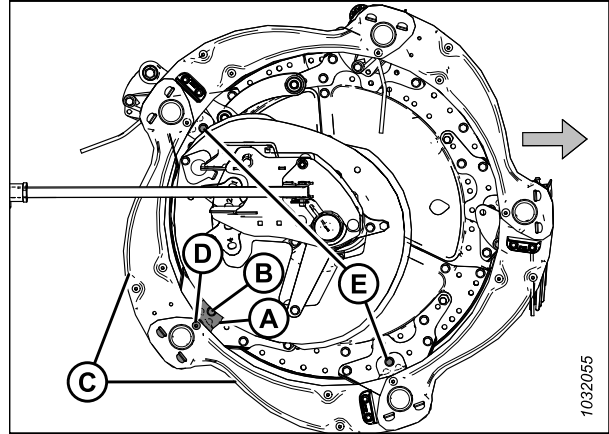


Figure 4.320: Reel Endshield Supports

## 4.14 Reel Drive

The hydraulically driven reel motor drives a chain that is attached to the center arm between the reels on a double-reel header, and to the left-center arm on a triple-reel header.

### 4.14.1 Reel Drive Chain

The reel drive chain transfers power from the hydraulically driven reel motor to the sprockets that rotate the reels.

#### *Loosening Reel Drive Chain*

The tension on the reel drive chain can be loosened to allow access to drive components.

#### **DANGER**

To prevent bodily injury or death from the unexpected start-up of the machine, always stop the engine and remove the key from the ignition before making adjustments to the machine.

#### **DANGER**

Ensure that all bystanders have cleared the area.

1. Lower the header fully.
2. Adjust the reel fully forward.
3. Shut down the engine, and remove the key from the ignition.
4. Remove the reel drive cover. For instructions, refer to *Removing Reel Drive Cover, page 49*.
5. Open the endshield. For instructions, refer to *Opening Header Endshields, page 41*.
6. Remove hairpin (A) securing multi-tool (B) to the bracket on the left endsheet.
7. Remove multi-tool (B), and reinstall the hairpin on the bracket.

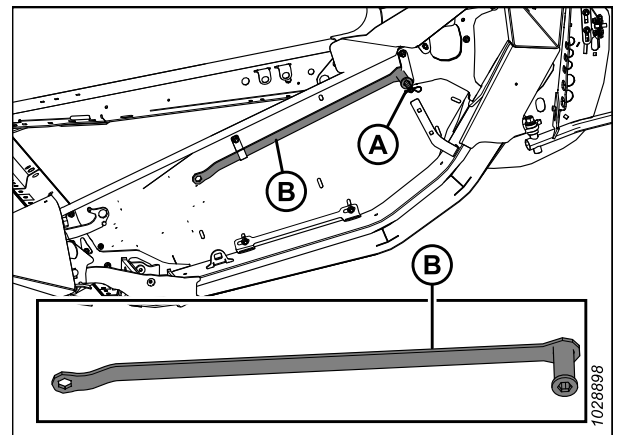


Figure 4.321: Multi-Tool Storage Location

## MAINTENANCE AND SERVICING

### IMPORTANT:

Do **NOT** loosen the motor mount, as it is factory-adjusted and secured with Belleville washers. Adjust the chain tension without loosening the drive mounting bolts.

8. Push tension retainer (A) clockwise with your thumb, and hold it in the unlocked position.
9. Place multi-tool (B) onto chain tensioner (C), and rotate the multi-tool upwards to loosen the chain tension.
10. Return the multi-tool to the storage position.

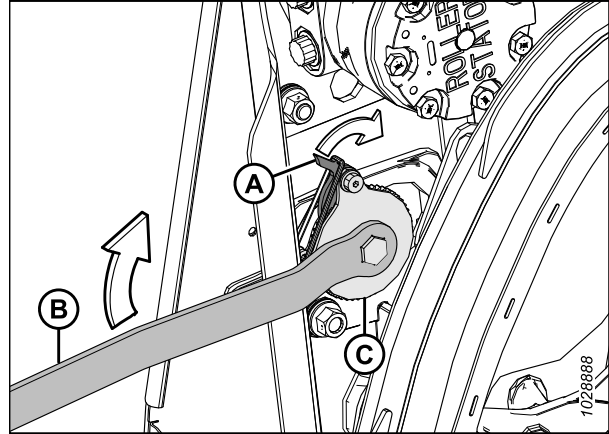


Figure 4.322: Reel Drive

### Tightening Reel Drive Chain

A correctly tensioned drive chain ensures optimum power transfer while minimizing component wear.

### DANGER

To prevent bodily injury or death from the unexpected start-up of the machine, always stop the engine and remove the key from the ignition before making adjustments to the machine.

1. Shut down the engine, and remove the key from the ignition.
2. Open the endshield. For instructions, refer to [Opening Header Endshields, page 41](#).
3. Remove hairpin (A) securing multi-tool (B) to the bracket on the left endsheet.
4. Remove multi-tool (B), and reinstall the hairpin on the bracket.

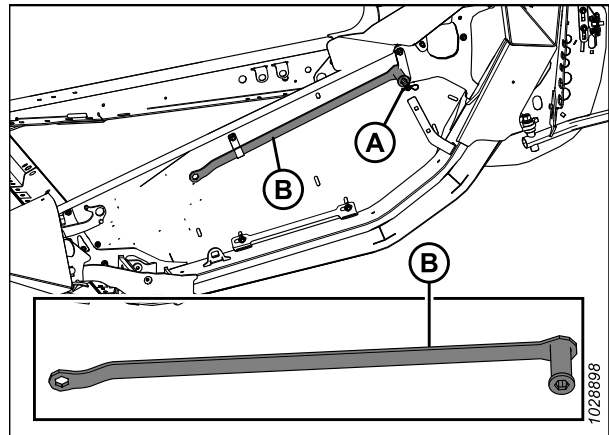


Figure 4.323: Multi-Tool Storage Location – Left Side



## MAINTENANCE AND SERVICING

- Place multi-tool (A) onto chain tensioner (B).

### IMPORTANT:

Do **NOT** loosen the motor mount, as it is factory-adjusted and secured with Belleville washers. Adjust the chain tension without loosening the drive mounting bolts.

- Rotate multi-tool (A) downward until the chain is tight.

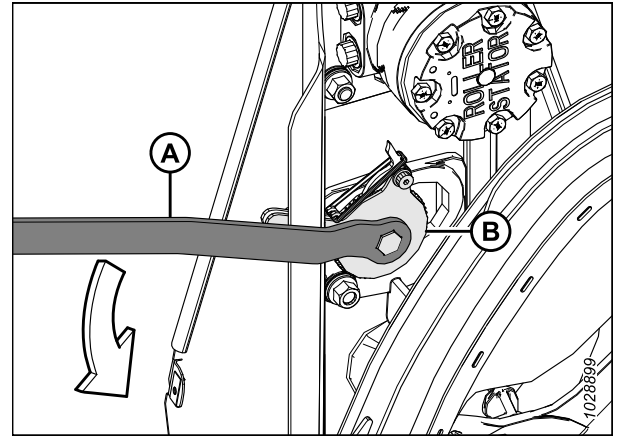


Figure 4.324: Reel Drive

- Once the chain is tight, rotate the multi-tool upward to properly engage the teeth from the lock/latch into the tightener teeth. If the tightener will not skip a tooth before tightening, do **NOT** force the tightener to the next notch.

### IMPORTANT:

Do **NOT** overtighten the chain. If the chain is too tight, it can put an excessive load on the sprockets, causing the motor bearings and/or other components to fail prematurely.

### IMPORTANT:

There should be approximately 38 mm (1 1/2 in.) of play on one side (A) of the chain, while it is tight on the other side (B). This level of tension and play in the chain is required to skip one notch on the chain tightener.

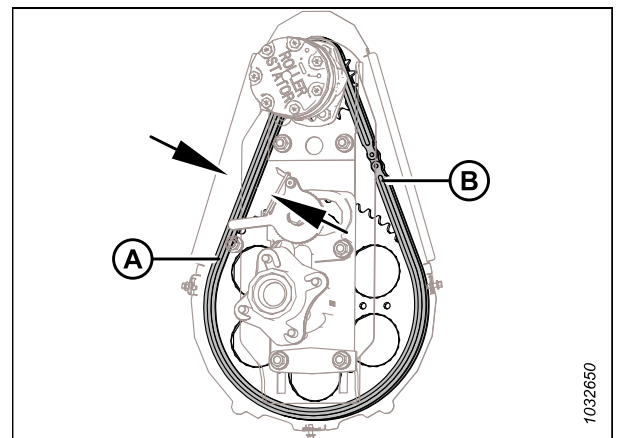


Figure 4.325: Reel Drive

- Rotate the reel by hand to ensure that the chain properly engages all teeth on lower sprocket (A). To prevent damage, ensure that the chain does not become too tight as the reel rotates.
- Return the multi-tool to the storage position.
- Close the endshield. For instructions, refer to [Closing Header Endshields, page 42](#).

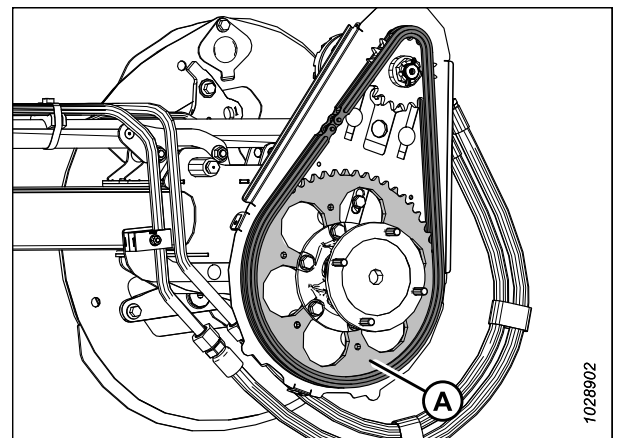


Figure 4.326: Reel Drive

## 4.14.2 Reel Drive Sprocket

The reel drive sprocket is attached to the reel drive motor.

### *Removing Reel Drive Single Sprocket*

The reel drive sprocket is attached to the reel drive motor. The speed and torque of the reel can be changed by changing the drive and driven sprockets.

### DANGER

To prevent injury or death from the unexpected start-up of the machine, always stop the engine and remove the key from the ignition before leaving the operator's seat for any reason.

1. Shut down the engine, and remove the key from the ignition.
2. Remove the reel drive cover. For instructions, refer to [Removing Reel Drive Cover, page 49](#).
3. Loosen reel drive chain (A). For instructions, refer to [Loosening Reel Drive Chain, page 749](#).
4. Remove reel drive chain (A) from reel drive sprocket (B).

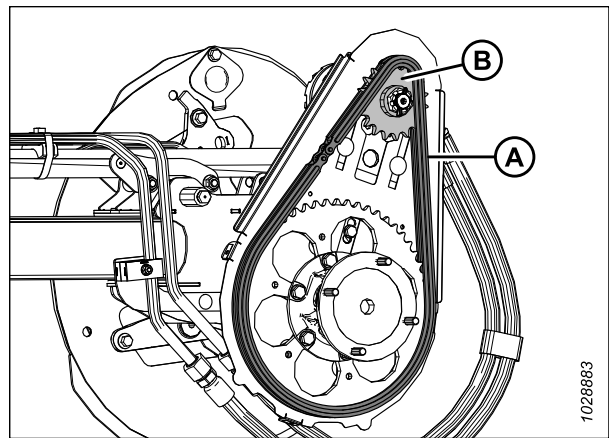


Figure 4.327: Single Sprocket

5. Remove the cotter pin and slotted nut (A) from the motor shaft.
6. Remove reel drive sprocket (B). Ensure that the key remains in the shaft.

#### **IMPORTANT:**

To avoid damaging the motor, use a puller if drive sprocket (B) does not come off by hand. Do **NOT** use a pry bar and/or hammer to remove the drive sprocket.

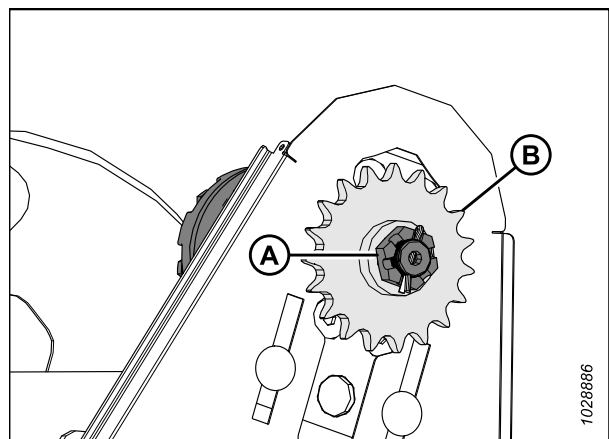


Figure 4.328: Single Sprocket

### Installing Reel Drive Single Sprocket

The reel drive sprocket is attached to the reel drive motor. The speed and torque of the reel can be changed by changing the drive and driven sprockets.

#### DANGER

To prevent injury or death from the unexpected start-up of the machine, always stop the engine and remove the key from the ignition before leaving the operator's seat for any reason.

1. Align the keyway in sprocket (B) with the key on the motor shaft, and slide the sprocket onto the shaft. Secure it with slotted nut (A).
2. Torque slotted nut (A) to 12 Nm (8.85 lbf·ft [106 lbf-in]).
3. Install the cotter pin. If necessary, tighten slotted nut (A) to the next slot to install the cotter pin.

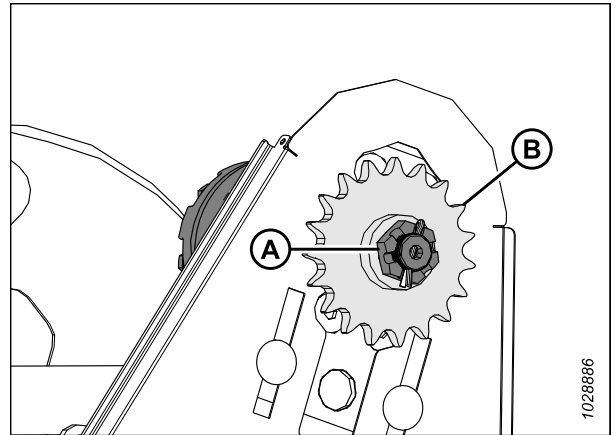


Figure 4.329: Single Sprocket

4. Install drive chain (A) onto drive sprocket (B).
5. Tighten the drive chain. For instructions, refer to [Tightening Reel Drive Chain, page 750](#).
6. Reinstall the reel drive cover. For instructions, refer to [Installing Reel Drive Cover, page 51](#).

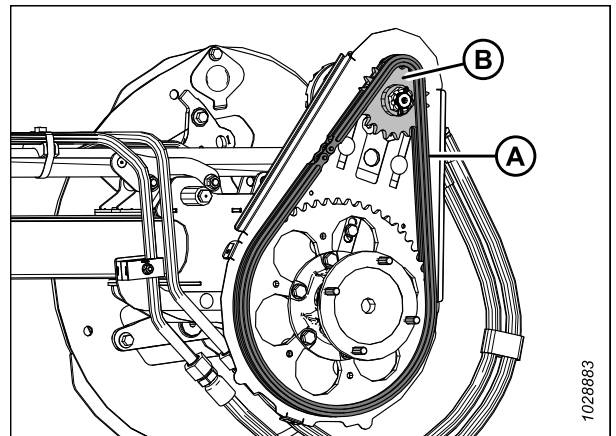
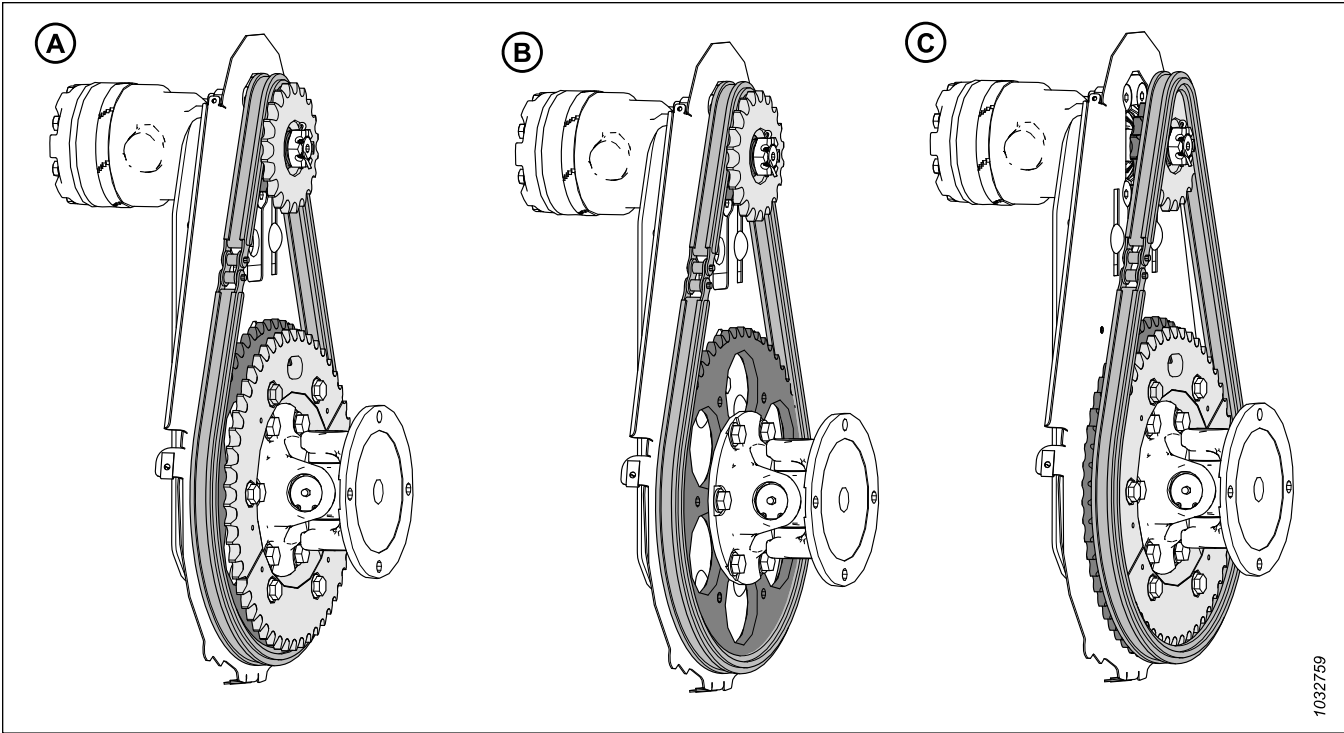


Figure 4.330: Single Sprocket

### Removing Reel Drive Optional Dual Sprocket

Follow this procedure to remove the reel drive optional dual sprocket.

This procedure is applicable to all configurations shown in [Figure 4.331, page 754](#).



**Figure 4.331: Reel Drive Configurations—Optional Dual Sprockets**

A - Dual Sprocket in High-Torque Configuration WITH the Optional 52-Tooth Sprocket Installed but NOT Required

B - Dual Sprocket in High-Torque Configuration WITHOUT the Optional 52-Tooth Sprocket

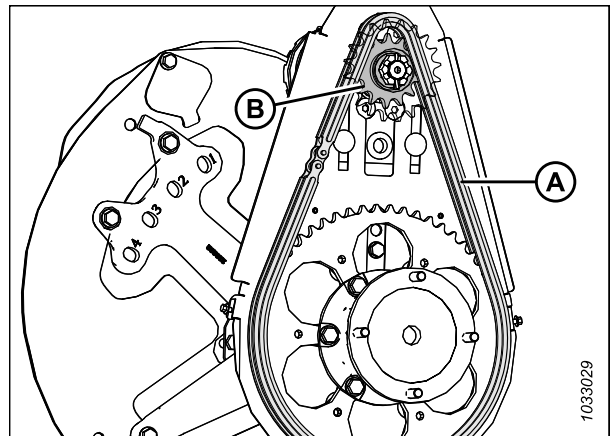
C - Dual Sprocket in High-Speed Configuration WITH the Optional 52-Tooth Sprocket Installed and Required

**⚠ DANGER**

To prevent injury or death from the unexpected start-up of the machine, always stop the engine and remove the key from the ignition before leaving the operator’s seat for any reason.

To remove the optional dual sprocket, do the following:

1. Shut down the engine, and remove the key from the ignition.
2. Remove the reel drive cover. For instructions, refer to *Removing Reel Drive Cover, page 49*.
3. Loosen reel drive chain (A). For instructions, refer to *Loosening Reel Drive Chain, page 749*.
4. Remove reel drive chain (A) from reel drive dual sprocket (B).



**Figure 4.332: Dual Sprocket in High-Torque Configuration**

## MAINTENANCE AND SERVICING

5. Remove the cotter pin and slotted nut (A) from motor shaft (B).
6. Remove reel drive dual sprocket (C). Ensure that the key remains in the shaft.

### IMPORTANT:

To avoid damaging the motor, use a puller if drive sprocket (B) does not come off by hand. Do **NOT** use a pry bar and/or hammer to remove the drive sprocket.

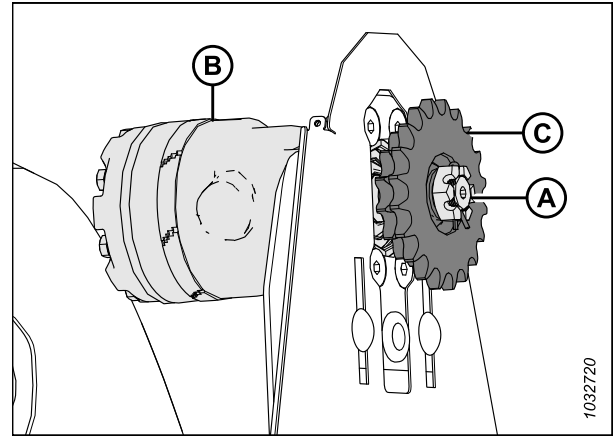


Figure 4.333: Dual Sprocket

### Installing Reel Drive Optional Dual Sprocket

Follow the procedure to install the reel drive optional dual sprocket.

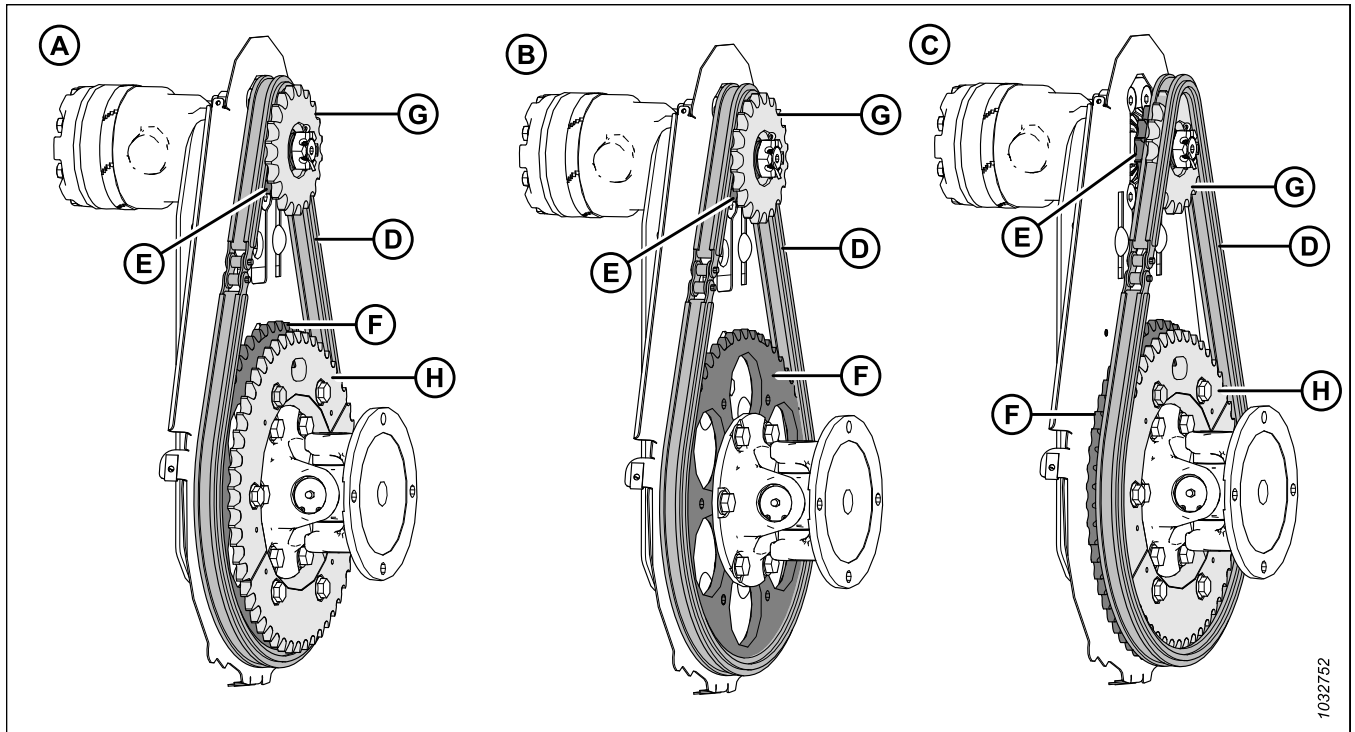


Figure 4.334: Reel Drive Configurations—Optional Dual Sprockets

A - Dual Sprocket in High-Torque Configuration WITH the Optional 52-Tooth Sprocket Installed but NOT Required

B - Dual Sprocket in High-Torque Configuration WITHOUT the Optional 52-Tooth Sprocket

C - Dual Sprocket in High-Speed Configuration WITH the Optional 52-Tooth Sprocket Installed and Required

The optional dual sprocket, when paired with the factory-installed 56-tooth sprocket, will provide more torque to the reel in heavy cutting conditions, and when paired with the optional 52-tooth sprocket will provide higher reel speed in light crops when operating at increased ground speed. In high-torque configuration (A) or (B), drive chain (D) is on inboard sprocket (E) and on factory-installed 56-tooth sprocket (F), whereas in high-speed configuration (C), drive chain (D) is on outboard sprocket (G) and on optional 52-tooth sprocket (H).

## MAINTENANCE AND SERVICING

### NOTE:

The optional 52-tooth sprocket (H) is **NOT** required for high-torque configuration.

### DANGER

To prevent injury or death from the unexpected start-up of the machine, always stop the engine and remove the key from the ignition before leaving the operator's seat for any reason.

To install the dual sprocket, do the following:

1. Position the dual sprocket so that smaller sprocket (A) is closer to reel motor (B).
2. Align the keyway in the sprocket with the key on the motor shaft, and slide the sprocket onto the shaft. Secure the sprocket with slotted nut (C).
3. Torque slotted nut (C) to 12 Nm (8.85 lbf-ft [106 lbf-in]).
4. Install cotter pin (D). If necessary, tighten slotted nut (C) to the next slot to install the cotter pin.

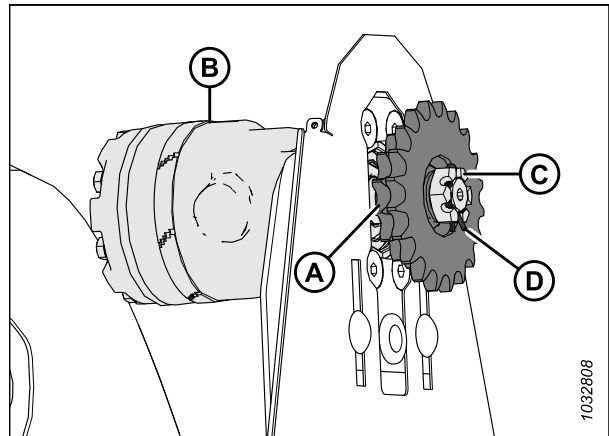


Figure 4.335: Dual Sprocket

5. For the high-torque configuration, install drive chain (A) onto inboard sprocket (B) and on factory-installed 56-tooth sprocket (C).

### NOTE:

Outboard sprocket (D) is illustrated as though it were transparent so that the inboard sprocket is visible.

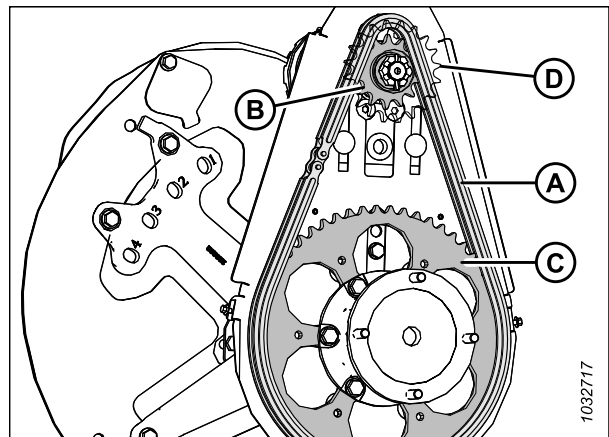


Figure 4.336: Dual Sprocket – High Torque Configuration



**NOTE:**

The optional 52-tooth sprocket is required for high-speed configuration.

6. For the high-speed configuration, position drive chain (A) onto outboard sprocket (B) and on optional 52-tooth sprocket (C).
7. Tighten the drive chain. For instructions, refer to [Tightening Reel Drive Chain, page 750](#).
8. Reinstall the reel drive cover. For instructions, refer to [Installing Reel Drive Cover, page 51](#).

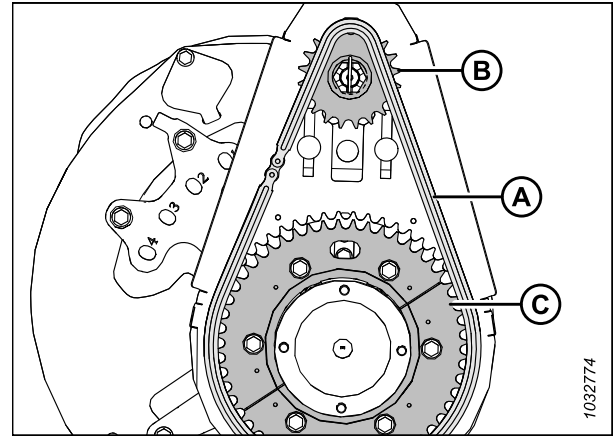


Figure 4.337: Dual Sprocket – High Speed Configuration

### 4.14.3 Changing Reel Speed Chain Position with Two Speed Kit Installed

The reel drive sprocket is attached to the reel drive motor. The speed and torque of the reel can be changed by changing the drive and driven sprockets.

**⚠ DANGER**

To prevent injury or death from the unexpected start-up of the machine, always stop the engine and remove the key from the ignition before leaving the operator’s seat for any reason.

1. Shut down the engine, and remove the key from the ignition.
2. Remove the reel drive cover. For instructions, refer to [Removing Reel Drive Cover, page 49](#).
3. Loosen the reel drive chain. For instructions, refer to [Loosening Reel Drive Chain, page 749](#).
4. Move chain (A) from the current set of sprockets to other set (B).

**NOTE:**

The inner set of sprockets are for high torque applications, and the outer set of sprockets are for high speed applications.

**NOTE:**

- If converting from the high speed setting to the high torque setting, move the chain on the top driver sprocket first. This will allow for more chain slack to make the change on the bottom driver sprocket.
- If converting from the high torque setting to the high speed setting, move the chain on the bottom driven sprocket first. This will allow for more slack to make the change on the top driver sprocket.

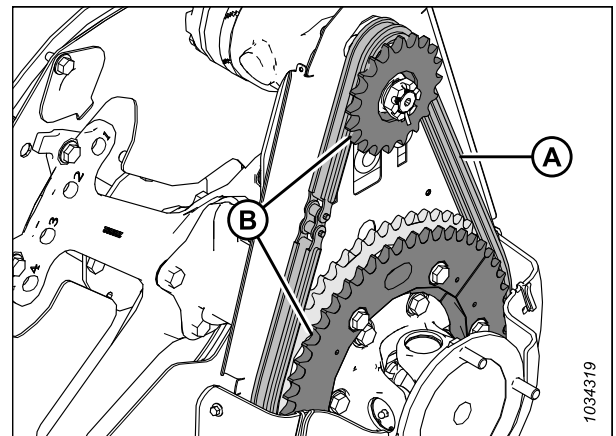


Figure 4.338: Reel Drive Sprocket

5. Tighten the reel drive chain. For instructions, refer to [Tightening Reel Drive Chain, page 750](#).

#### 4.14.4 Reel Speed Sensor

The reel speed sensors (and the procedures for replacing them) vary with the combine model.

Refer to the following topics depending on your combine model:

##### *Replacing Challenger®, Gleaner®, IDEAL™, or Massey Ferguson® Reel Speed Sensor*

The reel speed sensor is located on the reel drive and senses how fast the reel drive sprocket is turning. If malfunctioning, it may need adjustment or replacement.

### DANGER

**To prevent injury or death from the unexpected start-up of the machine, always stop the engine and remove the key from the ignition before leaving the operator's seat for any reason.**

1. Shut down the engine, and remove the key from the ignition.
2. Remove the drive cover. For instructions, refer to [Removing Reel Drive Cover, page 49](#).
3. Disconnect electrical connector (A) from the header harness.

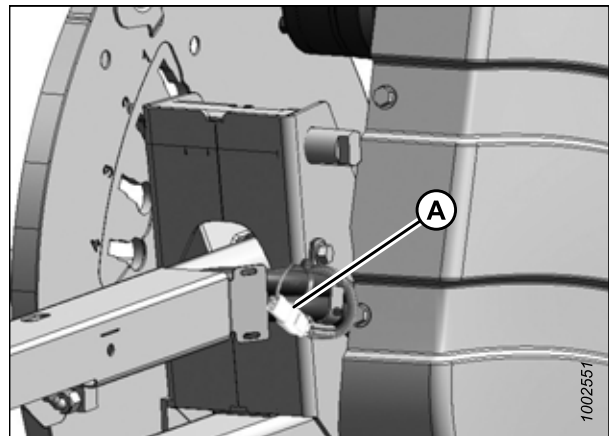


Figure 4.339: Reel Drive Assembly – Electrical Harness

4. Cut cable tie (A) securing the harness to the cover.
5. Remove two screws (B), sensor (C), and the harness. If necessary, bend cover (D) to remove the harness.
6. Feed the wire of the new sensor behind cover (D) and through the chain case.
7. Install the new sensor onto support (E) and attach it with two screws (B).
8. Adjust the gap between sensor disc (F) and sensor (C) to 3.5 mm (1/8 in.).

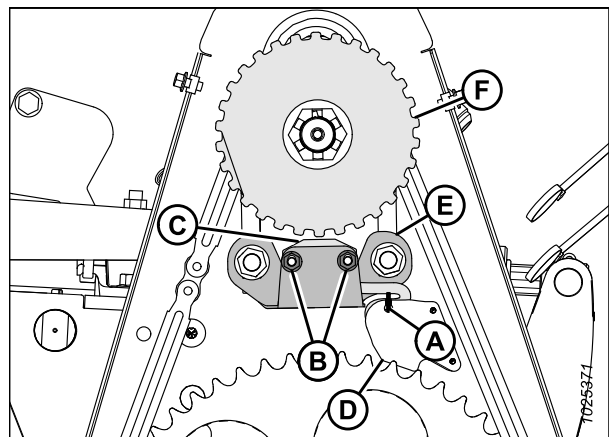


Figure 4.340: Reel Drive Assembly – Speed Sensor



9. Connect the sensor harness to header harness (A).

**IMPORTANT:**

Ensure that the sensor electrical harness does **NOT** contact the chain or sprocket.

10. Reinstall the drive cover. For instructions, refer to *Installing Reel Drive Cover, page 51*.
11. Ensure that the sensor is working correctly.

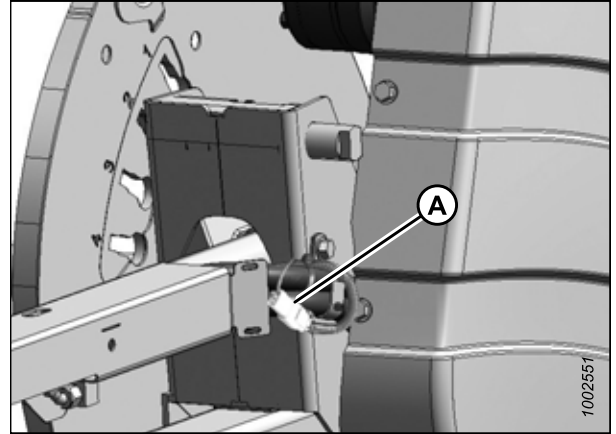


Figure 4.341: Reel Drive Assembly – Electrical Harness

*Replacing CLAAS Reel Speed Sensor*

The reel speed sensor is located on the reel drive and it senses how fast the reel drive sprocket is turning. If the sensor is malfunctioning, it may need to be adjusted or replaced.

**! DANGER**

To prevent injury or death from the unexpected start-up of the machine, always stop the engine and remove the key from the ignition before leaving the operator’s seat for any reason.

1. Shut down the engine, and remove the key from the ignition.
2. Remove the drive cover. For instructions, refer to *Removing Reel Drive Cover, page 49*.
3. Disconnect the header harness connector located behind the chain case from sensor (A).
4. Remove cable ties (B).
5. Remove shield (C) and rivets (D).
6. Remove nut (E) and remove sensor (A).
7. Position new sensor (A) into support (F). Secure it with nut (E).
8. Adjust the gap between sensor disc (G) and the sensor to 3.5 mm (1/8 in.). using nuts (E).
9. Route the harness through the knockout hole in the panel and connect it to sensor (A). Secure the harness in place with shield (C) and rivets (D).
10. Secure the harness to the sensor support with cable ties (B) as shown.

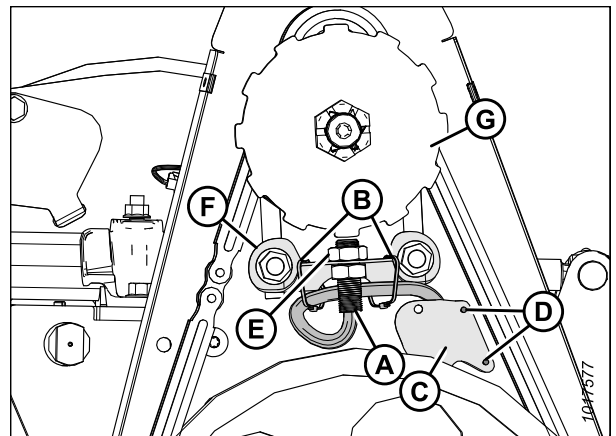


Figure 4.342: Speed Sensor

**IMPORTANT:**

Ensure that the sensor electrical harness does **NOT** contact the chain or sprocket.

11. Reinstall the drive cover. For instructions, refer to *Installing Reel Drive Cover, page 51*.

### Replacing John Deere Reel Speed Sensor

The reel speed sensor is located on the reel drive and it senses how fast the reel drive sprocket is turning. If the sensor is malfunctioning, it may need to be adjusted or replaced.

#### DANGER

To prevent injury or death from the unexpected start-up of the machine, always stop the engine and remove the key from the ignition before leaving the operator's seat for any reason.

1. Shut down the engine, and remove the key from the ignition.
2. Remove the drive cover. For instructions, refer to [Removing Reel Drive Cover, page 49](#).
3. Disconnect electrical connector (D) from the header harness (E).
4. Remove top nut (C) and remove sensor (B).
5. Remove the top nut from the new sensor and position the sensor onto the support. Secure it with top nut (C).
6. Adjust the gap between sensor disc (A) and sensor (B) to 1 mm (0.04 in.) using nut (C).
7. Connect electrical connector (D) to header harness (E).

#### IMPORTANT:

Ensure that the sensor electrical harness does **NOT** contact the chain or sprocket.

8. Reinstall the drive cover. For instructions, refer to [Installing Reel Drive Cover, page 51](#).

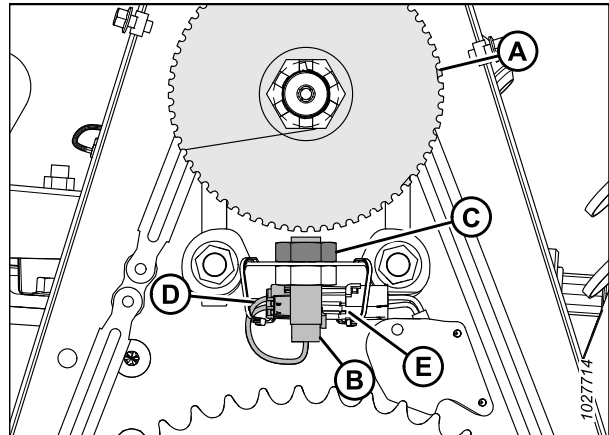


Figure 4.343: Speed Sensor

## 4.15 Contour Wheels – Option

The ContourMax™ Contour Wheels option allows the header to flex with the contours of the field leaving a consistent stubble height while cutting up to 46 cm (18 in.) above the ground.

### 4.15.1 Checking Wheel Bolt Torque — ContourMax™ Option

The wheel bolts securing the ContourMax™ wheels must be torqued twice.

#### DANGER

To prevent bodily injury or death from the unexpected start-up of the machine, always stop the engine and remove the key from the ignition before making adjustments to the machine.

1. Shut down the engine, and remove the key from the ignition.
2. Place the ContourMax™ wheel onto the hub.
3. Insert the five bolts that are used to secure the wheel.
4. Torque the bolts initially to 88 Nm (65 lbf-ft) according to the bolt-tightening sequence shown in the illustrations at right. Brace the wheel to prepare it for the final torque.
5. Torque the bolts again to a final torque value of 122 Nm (90 lbf-ft).
6. Repeat Step 2, page 761 to Step 5, page 761 for the other wheel.

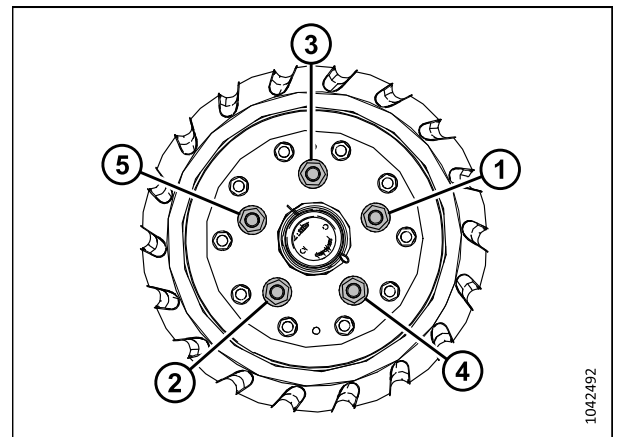


Figure 4.344: Sequence for Tightening Bolts on LH Wheel

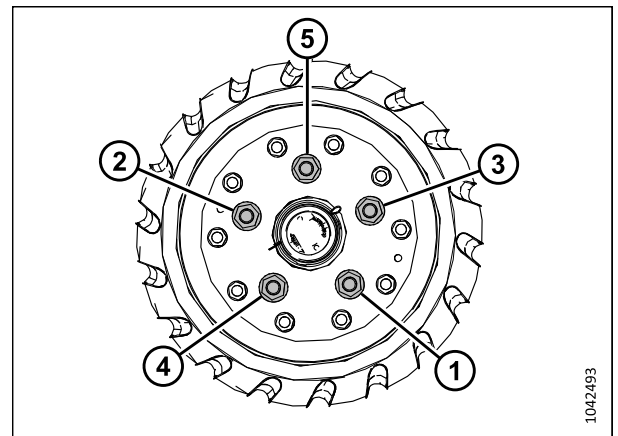


Figure 4.345: Sequence for Tightening Bolts on RH Wheel

## 4.15.2 Leveling Contour Wheel Height

The contour wheels allow the header to follow the contours of the ground, and can be adjusted between 25 mm (1 in.) and 457 mm (18 in.) from the ground surface.

### DANGER

To prevent bodily injury or death from the unexpected start-up or fall of a raised machine, always stop the engine and remove the key before leaving the operator's seat, and always engage the safety props before going under the machine for any reason.

### DANGER

Ensure that all bystanders have cleared the area.

#### NOTE:

Set the header float before leveling the contour wheels. For instructions, refer to *Checking and Adjusting Header Float*, page 210.

#### NOTE:

Set the wing balance before leveling the contour wheels. For instructions, refer to *3.9.4 Checking and Adjusting Wing Balance*, page 226.

1. Unlock the header wings. For instructions, refer to *Operating in Flex Mode*, page 221.
2. Unlock the header float. For instructions, refer to *Locking / Unlocking Header Float*, page 221.
3. Park the combine on a level surface.
4. Lower the reel fully.
5. Adjust the contour wheels so that height indicator (A) is at number 2 (B).

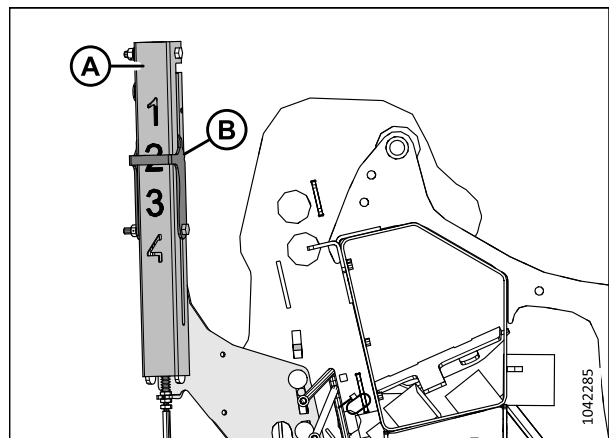


Figure 4.346: Height Indicator – Rear Left End

## MAINTENANCE AND SERVICING

6. Lower the header until auto header height indicator arm (A) is at number 2 (B).
7. Shut down the engine, and remove the key from the ignition.

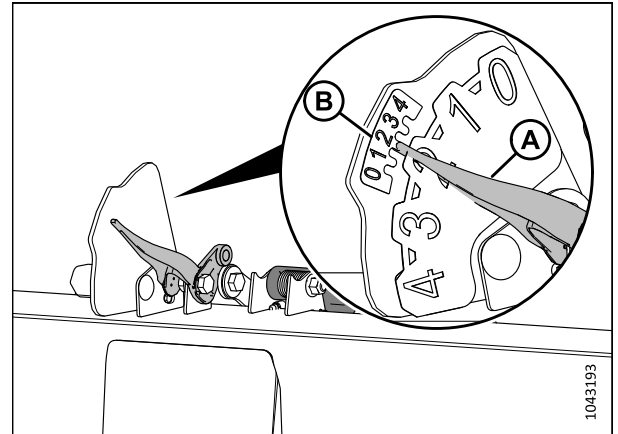


Figure 4.347: Auto Header Height Indicator

8. At the center of the header, measure distance (A) from the ground to the tip of the center guard. Record distance (A).
9. At each end of the header, measure distance (A) from the ground to the tip of the end guard. Record both of the measurements.
  - If the difference between the center measurement and the end measurements is less than 25 mm (1 in.), no adjustment is required.
  - If the difference between the center measurement and the end measurements is greater than 25 mm (1 in.), adjustment is required. Continue to the next step.
10. Start the engine.
11. Raise the header fully.
12. Shut down the engine, and remove the key from the ignition.
13. Engage the header safety props. For instructions, refer to the combine operator's manual.

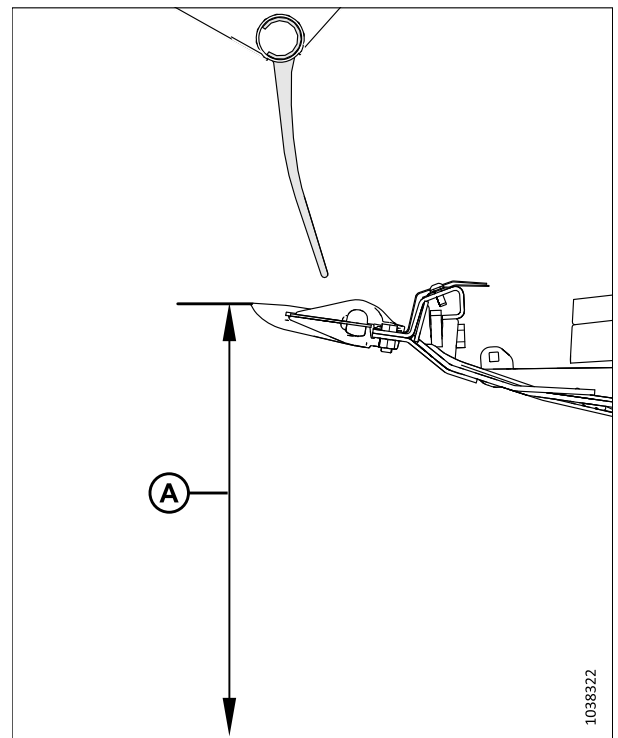


Figure 4.348: Float Setting Indicator

14. Remove pin (A).
15. Reposition adjuster plate (B) in the slot to align with a different hole. There is approximately a 24 mm (1/2 in.) difference between each of the holes.
  - If the measurement is less than the measurement at the center of the header, move the adjuster plate **TOWARD** the cutterbar.
  - If the measurement is more than the measurement at the center of the header, move the adjuster plate **AWAY** from the cutterbar.
16. Reinstall pin (A).
17. On the opposite end of the header, repeat Step 14, page 764 and Step 16, page 764.
18. Disengage the header safety props. Refer to the combine operator's manual for instructions.
19. Lower the header until auto header height indicator arm (A) is at number 2 (B).
20. Shut down the engine, and remove the key from the ignition.
21. Measure the guard to ground distance again. Ensure that the three measurements are the same. If more adjustment is required, repeat Steps 14, page 764 to 17, page 764.

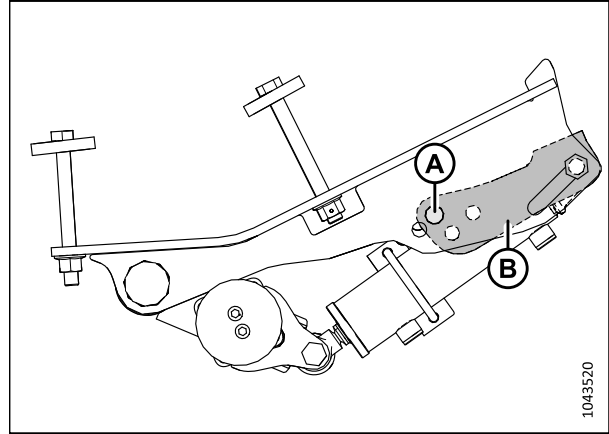


Figure 4.349: Pin Location – Left Outer Wheel

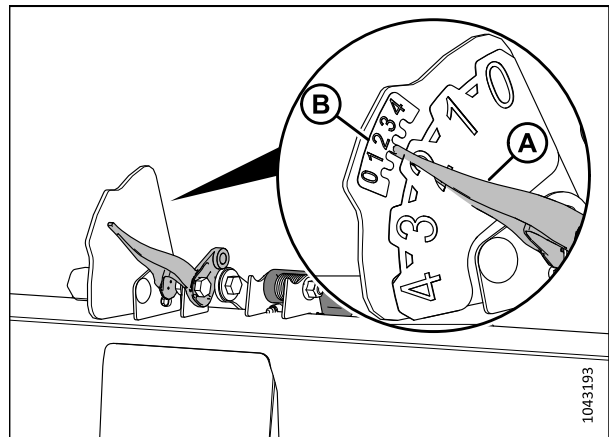


Figure 4.350: Auto Header Height Indicator

### 4.15.3 Lubricating Contour Wheel System

Lubricating the contour wheel system will help ensure reliable operation and maximize the service life of the components.

The components of the contour wheel system require lubrication at different intervals:

- Lubricate the inner wheel assemblies every 100 hours
- Lubricate the wheel axles annually

#### DANGER

To avoid bodily injury or death from unexpected startup or fall of raised header, stop the engine, remove the key, and engage the safety props before going under the header. If you are using a lifting device to support the header, be sure that the header is secure before proceeding.

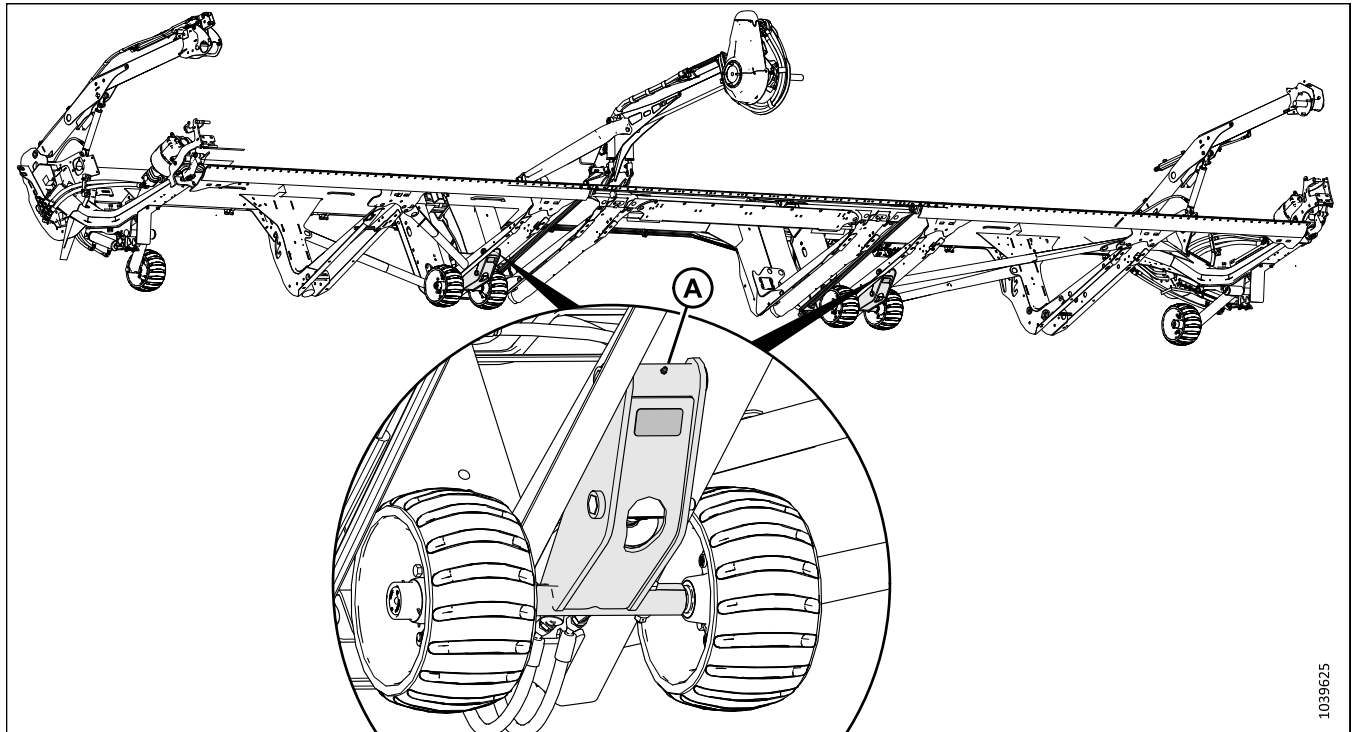
#### DANGER

Ensure that all bystanders have cleared the area.

## MAINTENANCE AND SERVICING

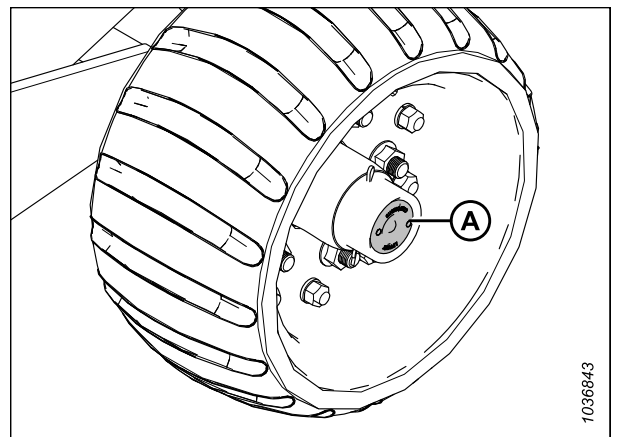
1. Raise the header fully.
2. Shut down the engine, and remove the key from the ignition.
3. Engage the header safety props or support the header on blocks on level ground. If you are using blocks to support the header, ensure the header is approximately 914 mm (36 in.) off the ground. For instructions on how to engage the header safety props, refer to the combine operator's manual.

**Figure 4.351: Inner Contour Wheel Assemblies**



A - Inner Wheel Assemblies (Two Places)

4. Lubricate points (A) at the two inner wheel assemblies.
5. Remove rubber plug (A) from the contour wheel hub. Retain the plug for reinstallation.



**Figure 4.352: Rubber Plug on Contour Wheel Axle**

## MAINTENANCE AND SERVICING

6. Apply grease at lubrication point (A), and allow the excess grease to flow out the front of the axle hub.

### IMPORTANT:

Grease the lubrication point **SLOWLY**. Rapid greasing may force the rear seal to move.

7. Reinstall rubber plug (B).
8. Repeat the procedure for the remaining contour wheels.

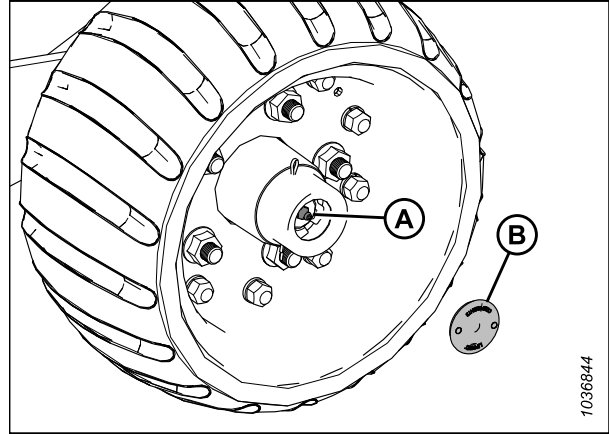


Figure 4.353: Lubrication Point on Contour Wheel Axle

### 4.15.4 Checking Contour Wheel End Play

The end play of a wheel refers to its movement along the spindle axis. If there is too much play on the wheel assembly, you will need to tighten the castle nut under the dust cap.

### DANGER

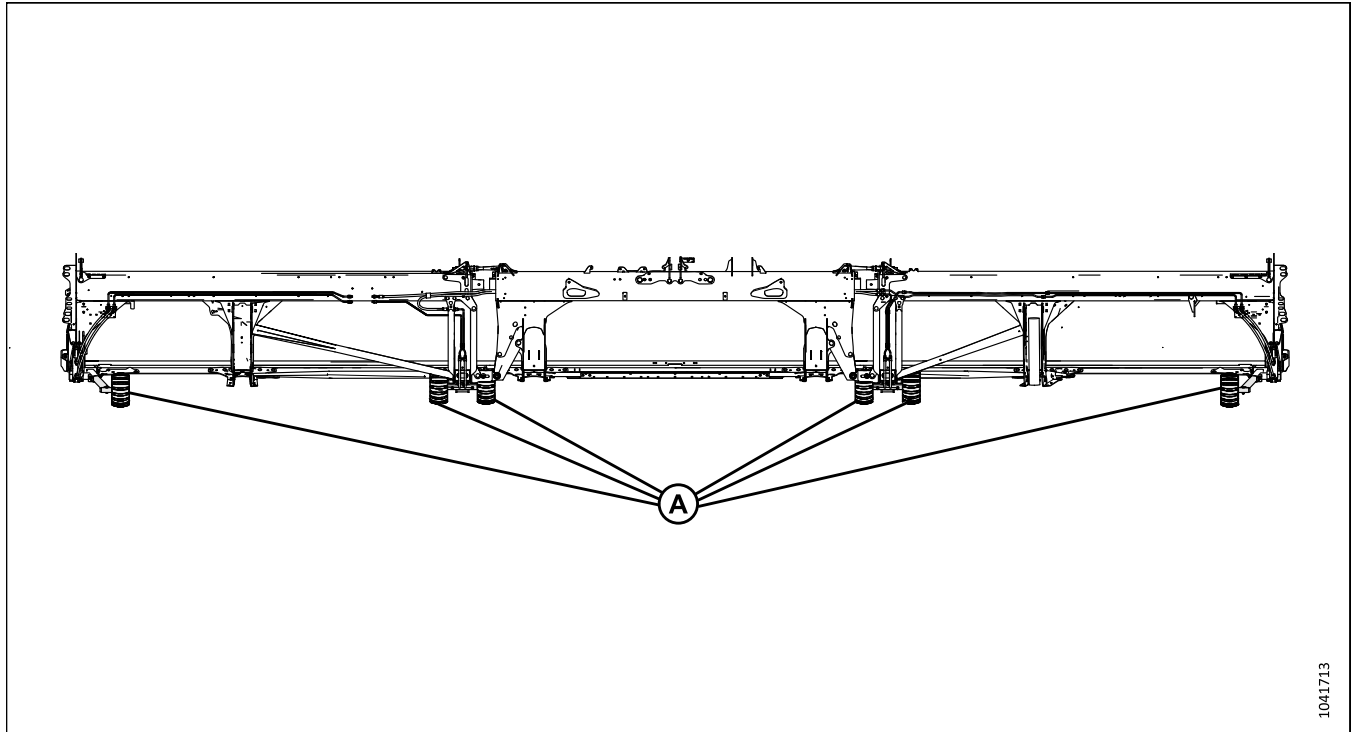
To prevent bodily injury or death from the unexpected start-up of the machine, always stop the engine and remove the key from the ignition before making adjustments to the machine.

1. Shut down the engine, and remove the key from the ignition.



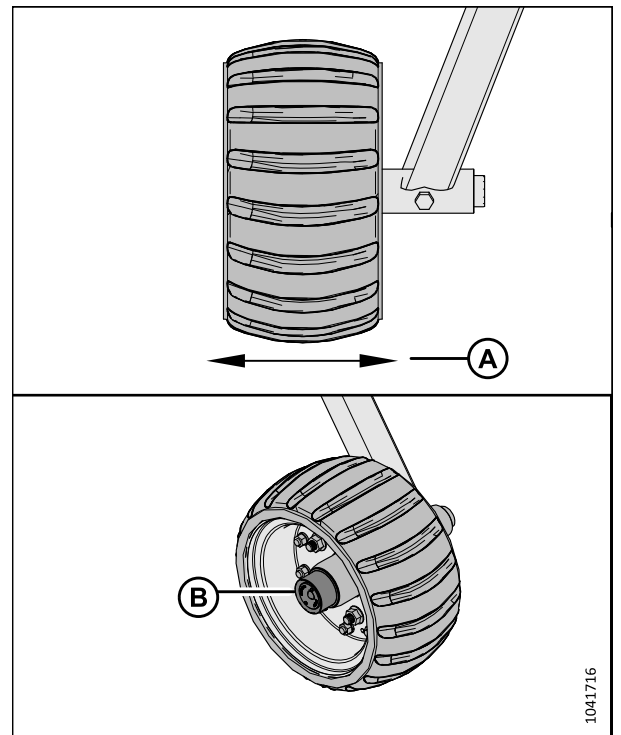
2. Check the end play on wheel assemblies (A).

Figure 4.354: ContourMax™ Wheel Assemblies



1041713

3. If end play (A) is greater than 0.30 mm (0.012 in.), remove dust cap (B).



1041716

Figure 4.355: ContourMax™ Wheel End Play and Dust Cap

## MAINTENANCE AND SERVICING

4. Remove cotter pin (A).
5. Tighten castle nut (B) until it is snug, then back off to the next slot in the castle nut.

**NOTE:**

There should be *SOME* play in the wheel assembly. Overtightening the castle nut can cause failure.

6. Reinstall cotter pin (A).
7. After tightening the assembly, lubricate spindle (C) until the grease comes out.
8. Reinstall the dust cap.

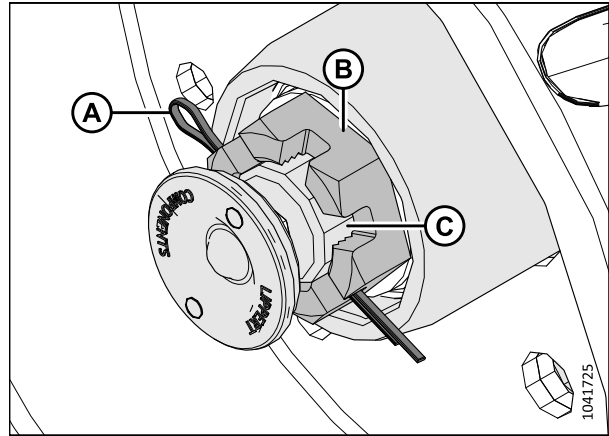


Figure 4.356: ContourMax™ Spindle

### 4.15.5 Zeroing Mechanical Indicator

The mechanical indicator will need to be zeroed to ensure that it operates accurately.

**⚠ DANGER**

To prevent bodily injury or death from the unexpected start-up or fall of a raised machine, always stop the engine and remove the key from the ignition before making adjustments to the machine. NEVER climb onto or go underneath an unsupported header.

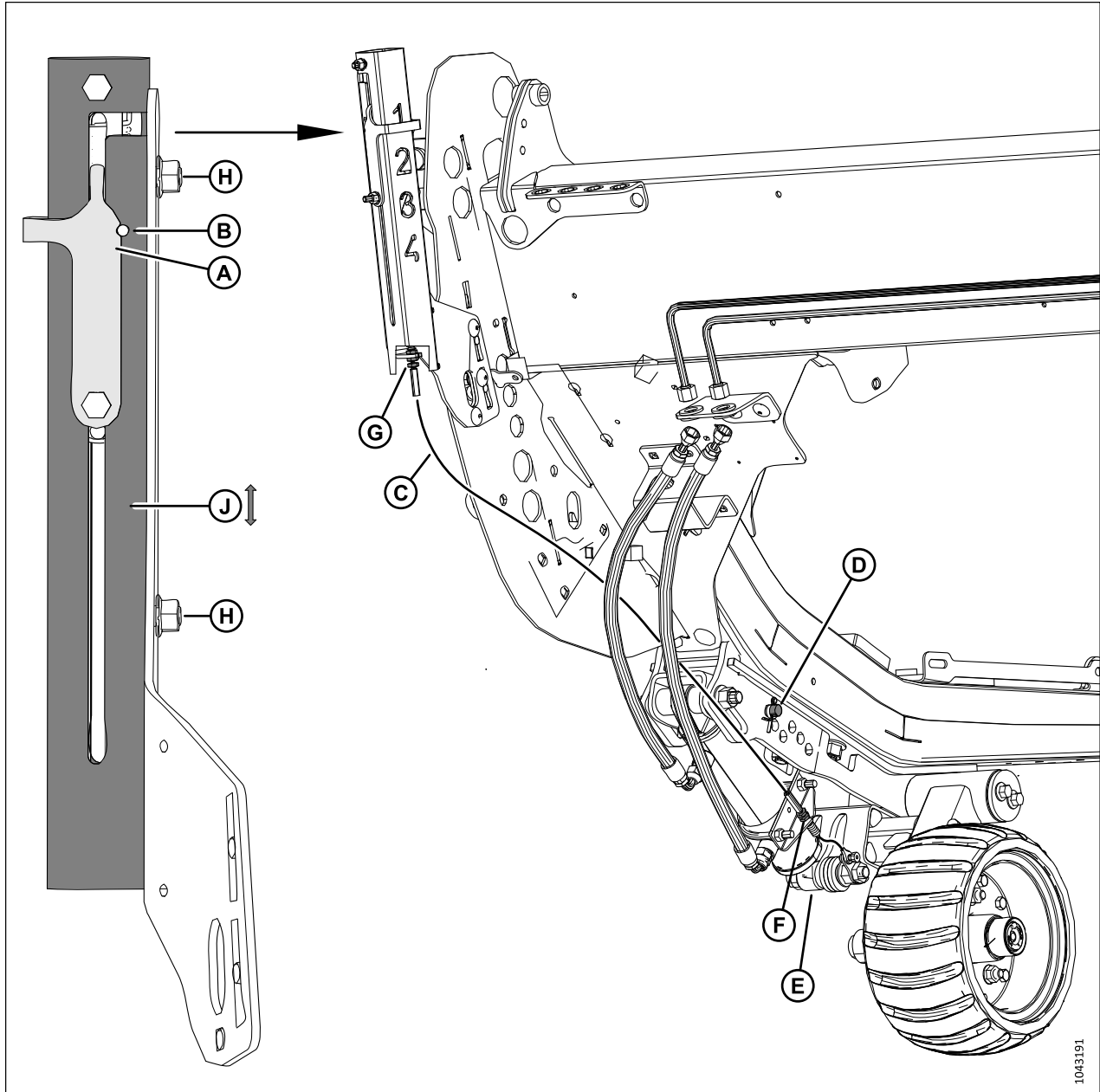


Figure 4.357: Mechanical Indicator

1. Shut down the engine, and remove the key from the ignition.
2. Check that the mechanical indicator is zeroed by ensuring that the notch in indicator (A) aligns with hole (B) under the following conditions:
  - Cable (C) is tight
  - The pin is installed in hole (D)
  - Cylinder (E) is fully retracted
3. If the notch does **NOT** align with the hole, adjust any or all of the following parts:
  - Loosen two nuts (H) and slide tube (J) up or down. Tighten the nuts.
  - Adjust cable jam nuts at locations (G) or (F). Torque the cable jam nuts to 6 Nm (4 lbf-ft [48 lbf-in]).

## 4.16 Transport System (Option)

The header can be equipped with a set of transport wheels, so that the header can be towed by a combine or tractor.

Refer to *Adjusting EasyMove™ Transport Wheels*, page 191 for more information.

### 4.16.1 Checking Wheel Bolt Torque

Check the transport wheel bolt torque 1 operating hour after installing the wheels, and every 100 operating hours thereafter.

#### DANGER

To prevent bodily injury or death from the unexpected start-up of the machine, always stop the engine and remove the key from the ignition before making adjustments to the machine.

1. Shut down the engine, and remove the key from the ignition.
2. In the order shown, tighten the bolts to 115 Nm (85 lbf-ft).

#### IMPORTANT:

After reinstalling a wheel, check the bolt torque after 1 hour of operation and every 100 hours thereafter.

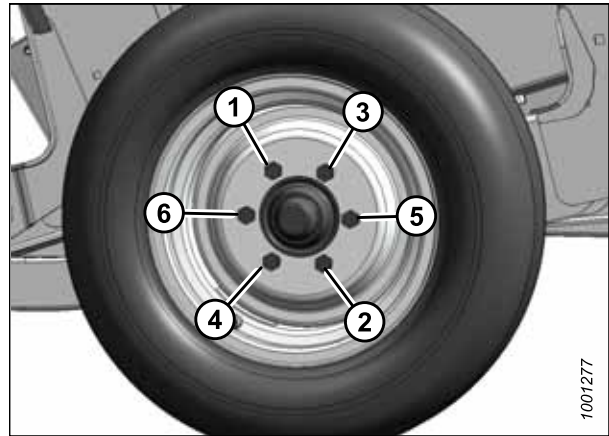


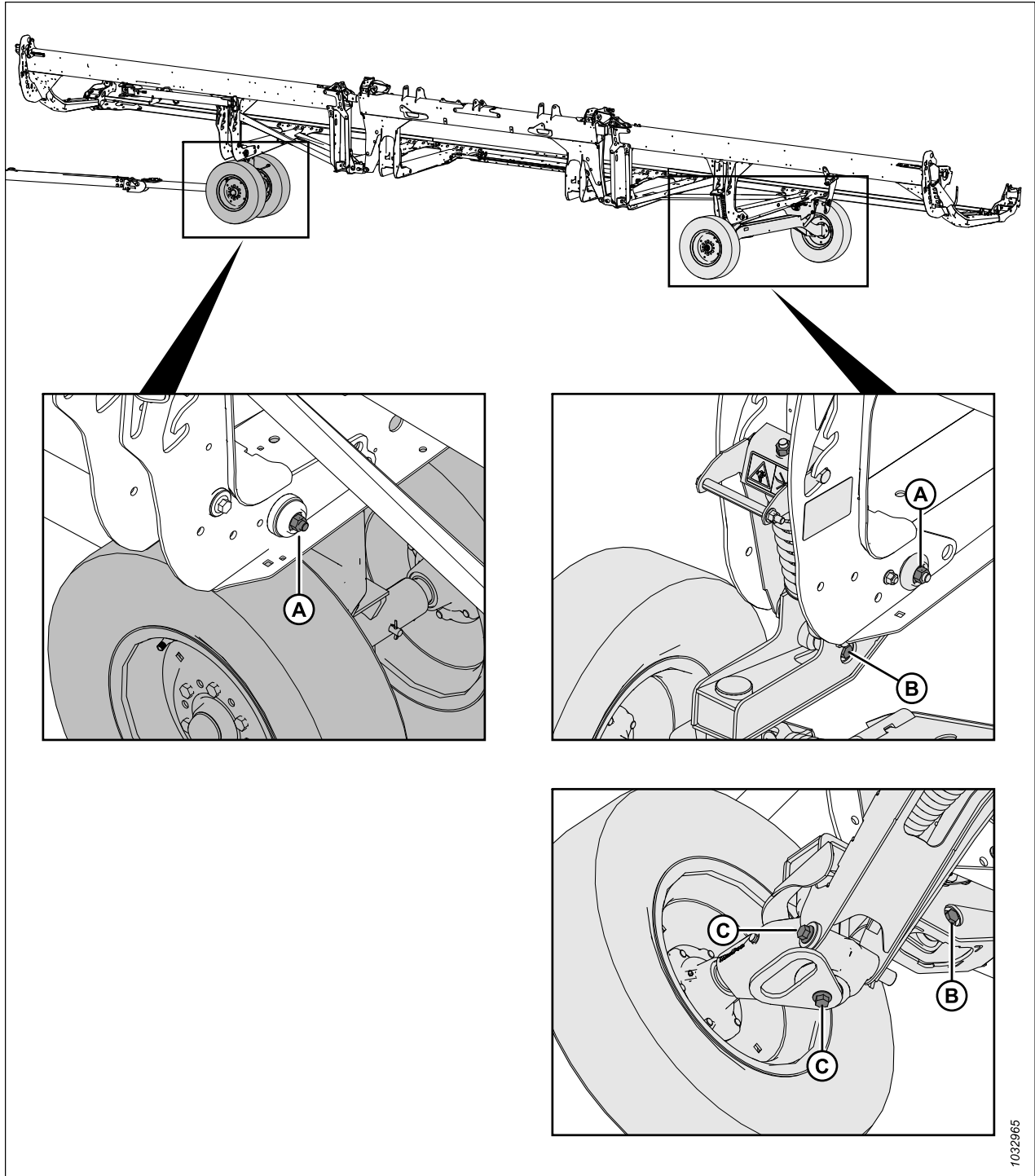
Figure 4.358: Bolt Tightening Sequence

### 4.16.2 Checking Transport Assembly Bolt Torque

To ensure safe operation, check the hardware that secures the optional transport system components to the header daily.

#### DANGER

To prevent bodily injury or death from the unexpected start-up of the machine, always stop the engine and remove the key from the ignition before making adjustments to the machine.



**Figure 4.359: Transport System Assembly Bolts**

1. Check the following bolts **DAILY** to ensure that the bolts are torqued to the specified values:
  - Bolts (A) to 234 Nm (173 lbf-ft)
  - Bolts (B) to 343 Nm (253 lbf-ft)
  - Bolts (C) to 343 Nm (253 lbf-ft)

### 4.16.3 Checking Tire Pressure

Proper tire pressure ensures the tires perform properly and wear evenly.

**⚠ WARNING**

- During inflation, a tire can explode and cause serious injury or death.
- Do NOT stand over the tire. Use a clip-on chuck and an extension hose.
- Do NOT exceed the maximum inflation pressure indicated on the tire label.
- Replace defective tires.
- Replace wheel rims that are cracked, worn, or severely rusted.
- Never weld a wheel rim.

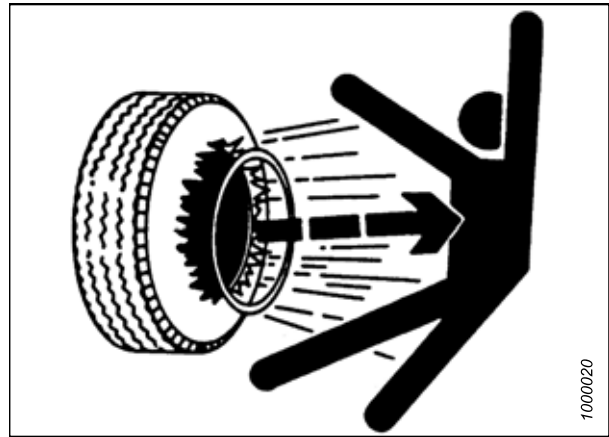


Figure 4.360: Inflation Warning

- Never use force on an inflated or a partially inflated tire.
  - Ensure that the tire is correctly seated before inflating it to operating pressure.
  - If the tire is not correctly positioned on the rim or if it is overinflated, the tire bead can loosen on one side causing air to escape at high speed and with great force. An air leak of this nature can thrust the tire in any direction endangering anyone in the area.
  - Remove all the air from a tire before removing it from the rim.
  - Do NOT remove, install, or repair a tire on a rim unless you have the proper equipment and experience to perform the job. Take the tire and rim to a qualified tire repair shop.
1. Check the tire pressure. For pressure specifications, refer to Table 4.4, page 772.
  2. Make sure the tire is correctly seated on the rim before inflating it. If the tire is not correctly positioned on the rim, take the tire to a qualified tire repair shop.
  3. If inflation is required, use a clip-on chuck and an extension hose to inflate the tire to the desired pressure.

**IMPORTANT:**

Do NOT exceed the maximum inflation pressure indicated on the tire label.

Table 4.4 Tire Inflation Pressure

Size	Load Range	Pressure
225/75 R15	F	655 kPa (95 psi)

### 4.16.4 Changing Tow-Bar Hitch Connection from Pintle to Clevis

The transport tow-bar includes clevis and pintle ring towing mounts.

1. Remove the hairpin from clevis pin (A) and disconnect chain (B). Store clevis pin (A) with the pintle hitch adapter.
2. Remove four nuts, four bolts, and eight flat washers (C) from the end of the tow-bar. Retain the hardware for reinstallation.

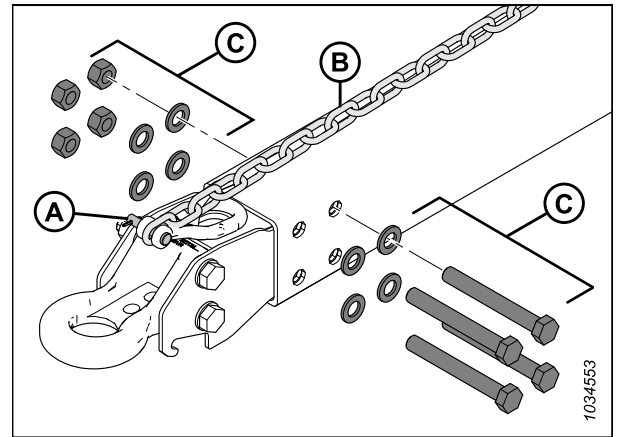


Figure 4.361: Removing Pintle Towing Adapter

3. Tape or tie 6 m (20 ft.) of pull-line to harness transport end (A).
4. Remove bolt (B) securing the harness in the P-clip. Retain the bolt.
5. From hitch end (C), gently pull the harness out through the opening in pintle (D) until you can see the pull-line, then disconnect the pull-line and set the pintle aside. Leave the pull-line inside the tow-bar.

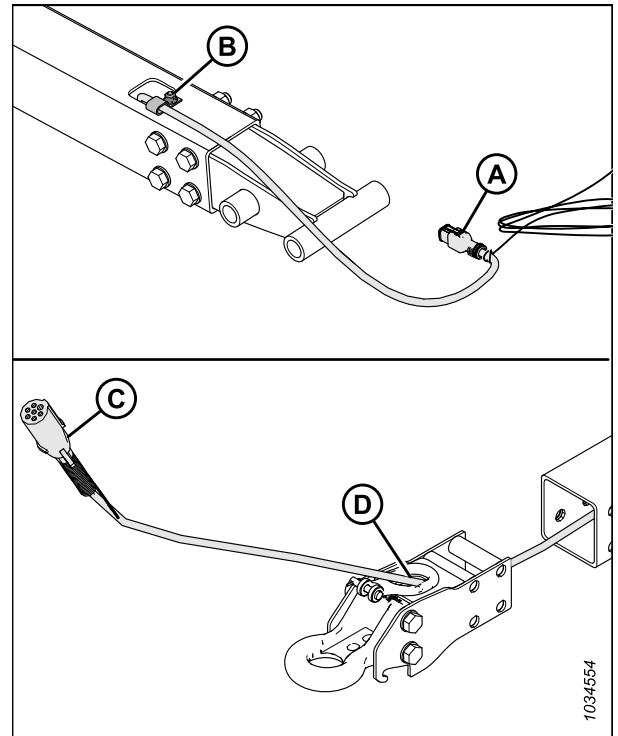


Figure 4.362: Removing Pintle Towing Adapter

## MAINTENANCE AND SERVICING

- Retrieve the clevis adapter.
- Insert transport connector (A) of the electrical harness through opening (B) in the ring on the clevis adapter.
- Secure pull-line (C) to the harness. Using the pull-line, gently pull the harness through the tow-bar.
- Ensure that transport end (A) of the harness extends 480 mm (18 7/8 in.) past P-clip (D).
- Secure the harness in the P-clip with the bolt from Step 6, [page 774](#).

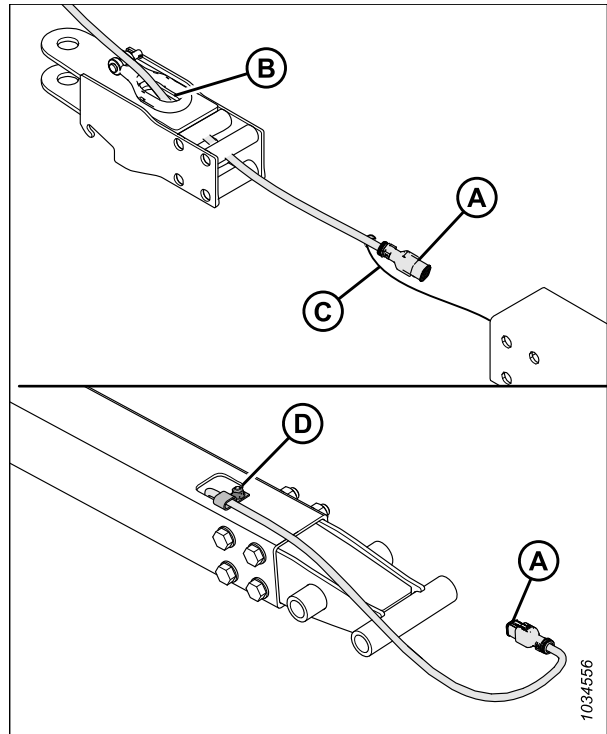


Figure 4.363: Installing Clevis Ring Adapter

- Install four nuts, four bolts, and eight flat washers (A) to secure the clevis adapter to the tow-bar.

**NOTE:**

Ensure that hardware (A) is reinstalled in the same orientation it was in before it was removed.

- Reconnect the chain with clevis pin (B) and secure it with the cotter pin.

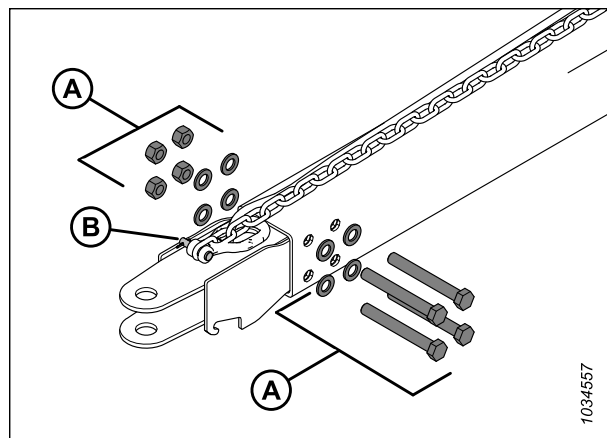


Figure 4.364: Installing Clevis Ring Adapter



## MAINTENANCE AND SERVICING

13. Tighten nuts (A) in the cross pattern shown. Recheck each nut in sequence until they are torqued to 310 Nm (229 lbf-ft).
14. Insert the hitch pin into the clevis adapter. Secure the pin with the lynch pin.

**NOTE:**

The pins are not shown in the illustration.

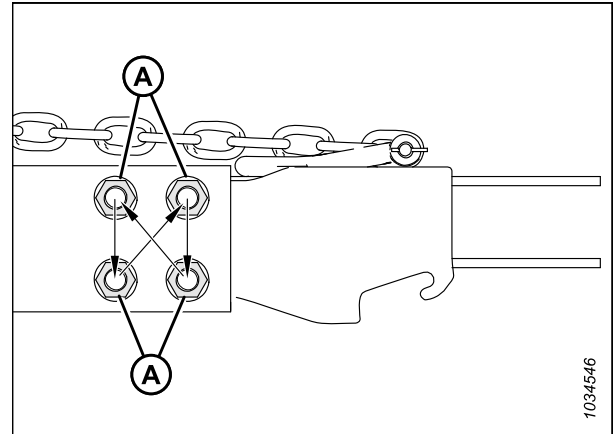


Figure 4.365: Torque Sequence

### 4.16.5 Changing Tow-Bar Hitch Connection from Clevis to Pintle

The transport tow-bar includes clevis and pintle ring towing mounts.

1. Remove the hairpin from clevis pin (A) and disconnect chain (B). Store clevis pin (A) with the clevis adapter.
2. Remove four nuts, four bolts, and eight flat washers (C) from the end of the tow-bar. Retain the hardware for reinstallation.

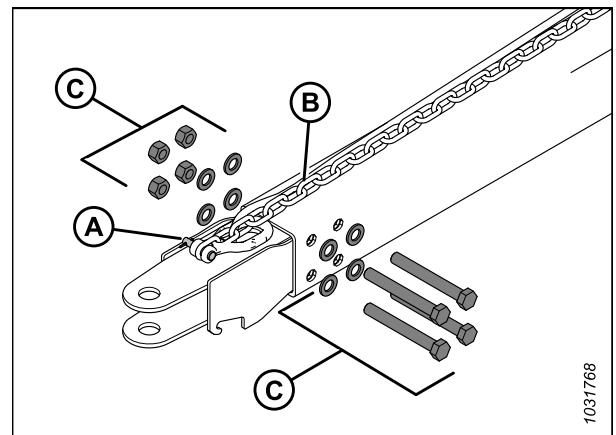


Figure 4.366: Removing Clevis Adapter

## MAINTENANCE AND SERVICING

3. Tape or tie 6 m (20 ft.) of pull-line to harness transport end (A).
4. Remove bolt (B) securing the harness in the P-clip. Retain the bolt for reinstallation.
5. From hitch end (C), gently pull the harness out through the opening in clevis (D) until you can see the pull-line, then disconnect the pull-line and set the clevis adapter aside. Leave the pull-line inside the tow-bar.

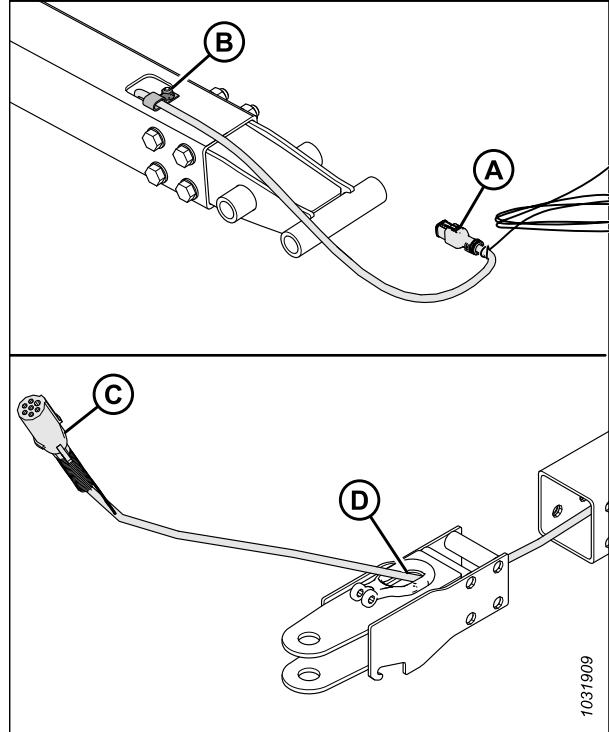


Figure 4.367: Removing Clevis Towing Adapter

6. Insert transport connector (A) of the electrical harness through opening (B) in the pintle ring adapter.
7. Tie or tape pull-line (C) to the harness. Gently pull the harness through the tow-bar with the pull line at the transport end.
8. Ensure that transport end (A) of the harness extends 480 mm (18 7/8 in.) past P-clip (D).
9. Secure the harness in the P-clip with the bolt removed in Step 4, page 776.

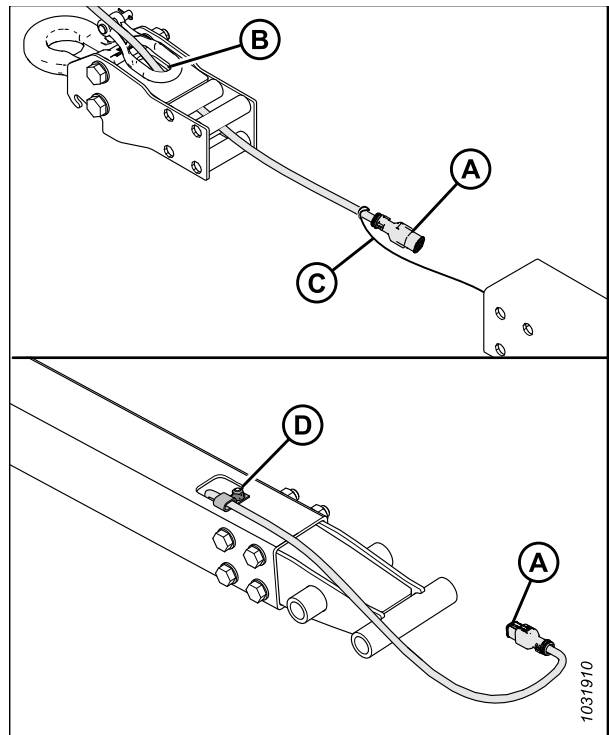


Figure 4.368: Installing Pintle Ring Adapter

## MAINTENANCE AND SERVICING

10. Reinstall four nuts, four bolts, and eight flat washers (A) to secure the pintle ring adapter to the tow-bar.

**NOTE:**

Ensure that hardware (A) is reinstalled with the four bolt heads on the same side.

11. Reconnect the chain with clevis pin (B) and secure it with the cotter pin.

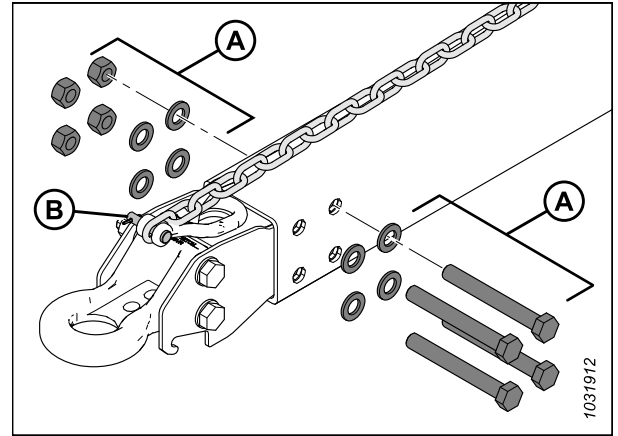


Figure 4.369: Installing Pintle Ring Adapter

12. Tighten nuts (A) in the cross pattern shown. Recheck each nut in sequence until they are torqued to 310 Nm (229 lbf-ft).

13. Insert the hitch pin into the pintle ring adapter. Secure the pin with the lynch pin.

**NOTE:**

The pins are not shown in the illustration.

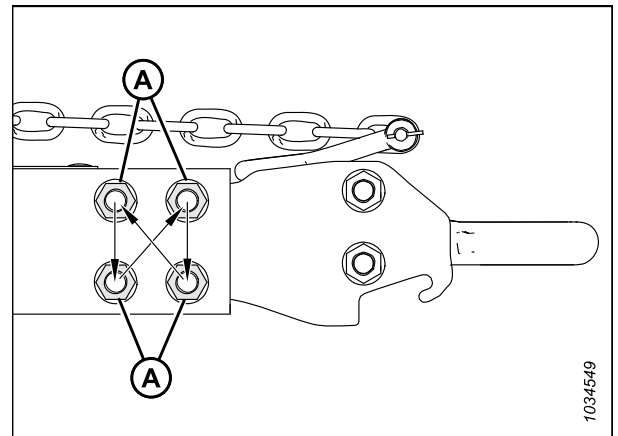


Figure 4.370: Torque Sequence

## 4.17 VertiBlade™ Vertical Knife (Option)

The optional vertical knife kit is a vertical crop cutter that is mounted to each end of the header. The vertical knife slices through tangled, shatter-prone crops such as canola to reduce seed loss.

### 4.17.1 Replacing Vertical Knife Sections

The VertiBlade™ Vertical Knife kit (sold separately) includes a service kit that supplies four replacement knife sections. Follow these instructions to replace a damaged knife section.

#### DANGER

To prevent bodily injury or death from the unexpected start-up or fall of a raised machine, always stop the engine and remove the key before leaving the operator's seat, and always engage the safety props before going under the machine for any reason.

#### DANGER

Ensure that all bystanders have cleared the area.

#### CAUTION

Install vertical knife guards before attaching or removing vertical knives. Wear heavy gloves when working around or handling knives.

#### NOTE:

The replacement vertical knife parts in this topic are sold separately with Vertical Knives kit (B7466).

1. Raise the header 254–356 mm (10–14 in.) off of the ground.
2. Shut down the engine, and remove the key from the ignition.
3. Engage the header safety props. For instructions, refer to the combine operator's manual.
4. Open the header endshields. For instructions, refer to [Opening Header Endshields, page 41](#).
5. Detach the vertical knife from the header. Set the vertical knife aside.
6. Remove retaining pin (A) from the knife guard.
7. Remove the knife guard using handle (B).

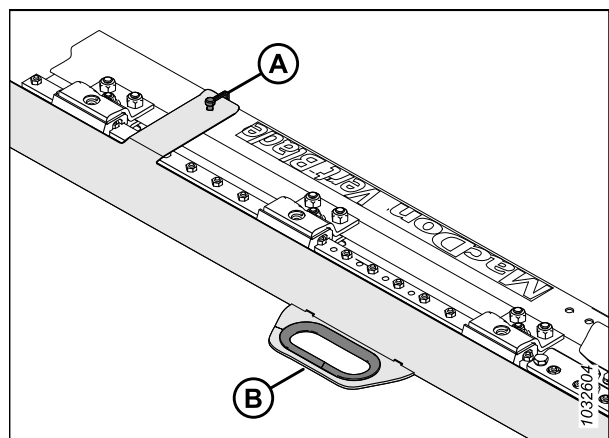


Figure 4.371: Vertical Knife Guard

## MAINTENANCE AND SERVICING

8. Remove three bolts (A) securing milling bar (B) to the blade bracket and knife section assembly (C).
9. Tilt milling bar (B) upward.
10. Slide assembly (C) out.

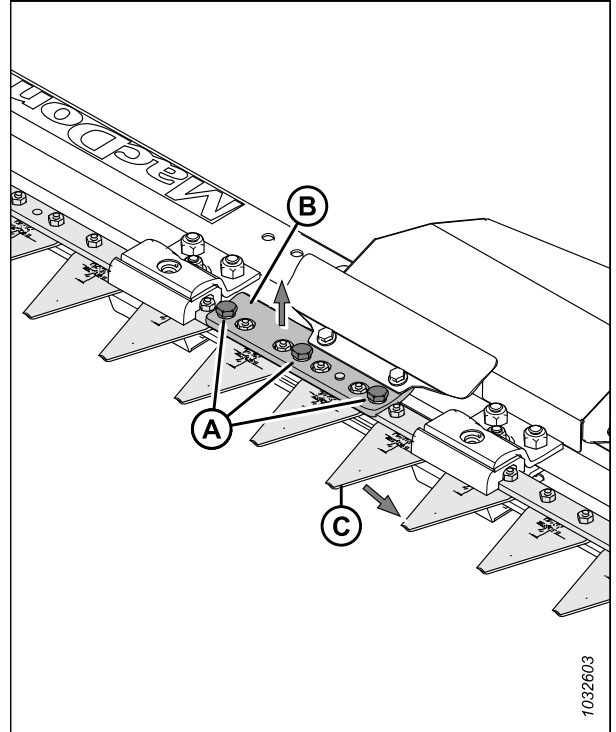


Figure 4.372: Vertical Knife – Guard Removed

### NOTE:

If you cannot tilt milling bar (A) upward enough to slide knife section assembly (B) out, remove bolts (C) securing hood (D) to the vertical knife assembly. Loosen nuts (E) securing slide rail (F). The milling bar should now be loose enough to tilt it upward.

### IMPORTANT:

If you need to loosen clip hardware (G) and clips (H) to slide the knife section assembly out, follow [Step 15, page 780](#) to properly tighten the hardware when the knife is installed.

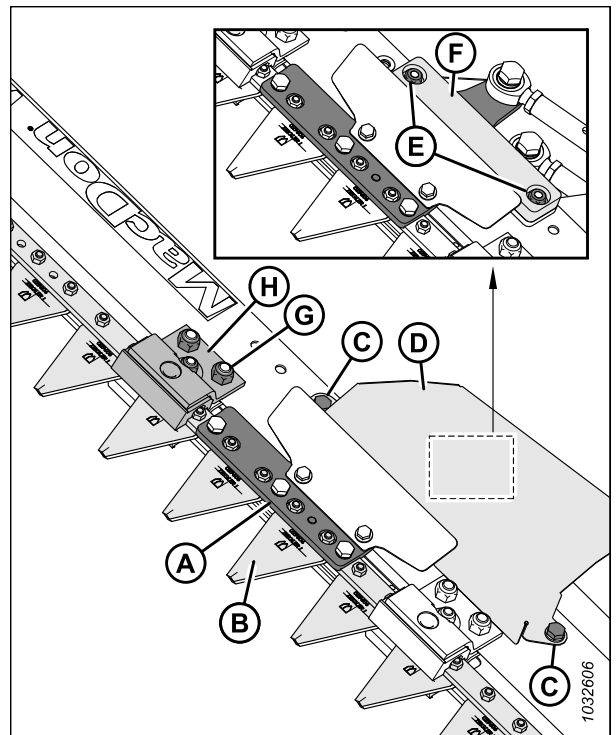


Figure 4.373: Vertical Knife – Guard Removed

## MAINTENANCE AND SERVICING

11. Remove two screws (A) and nuts (B) securing knife section (C) to bracket (D).
12. Apply medium-strength threadlocker (Loctite® 243 or an equivalent) to two new screws (A) (MD #313790).
13. Secure new knife section (C) (MD #313788) to bracket (D) using two screws (A) and nuts (B) (MD #313789).
14. Tighten nuts (B) to 7 Nm (5.16 lbf·ft [62 lbf·in]).

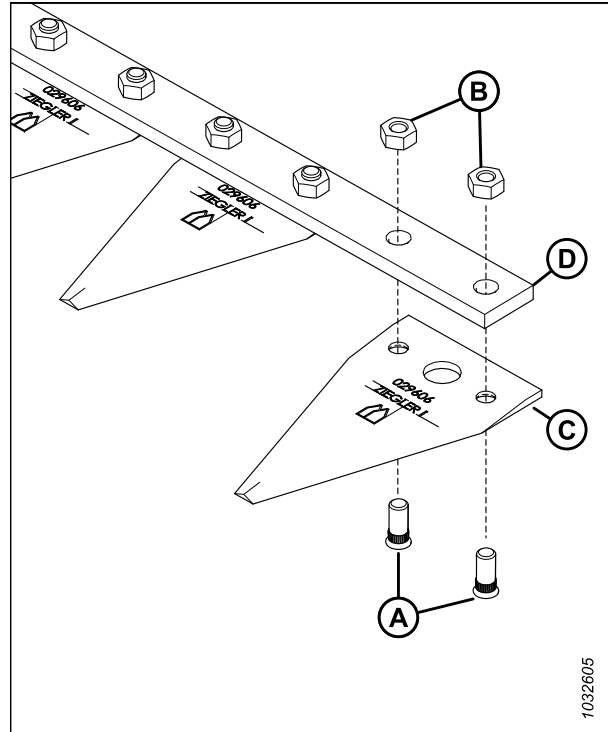


Figure 4.374: Knife Section Assembly

15. If you loosened clip hardware (A), (B), and clips (C) to slide the knife section assembly out, tighten the hardware as follows:

- a. Tighten M8 nut (A) so that gap (D) between knife sections (E) does **NOT** exceed 3 mm (1/8 in.).
- b. Ensure that clips (C) do **NOT** clamp the knife too tightly.

**NOTE:**

Excessively tight clips restrict the movement of the knife.

- c. Tighten nuts (B) to 50 Nm (37 lbf·ft).

16. Reinstall the remaining components and the knife guard. Installation is the reverse of removal.

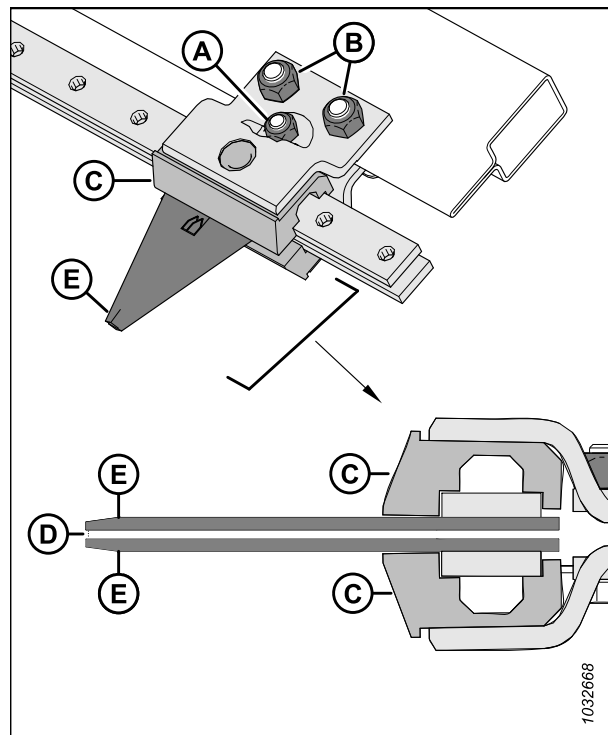


Figure 4.375: Gap Between Clip and Knife Section

### 4.17.2 Lubricating Vertical Knife

Each vertical knife has two lubrication points, which you can access by removing the knife's service panel.

**⚠ DANGER**

To prevent bodily injury or death from the unexpected start-up or fall of a raised machine, always stop the engine and remove the key before leaving the operator's seat, and always engage the safety props before going under the machine for any reason.

**⚠ DANGER**

Ensure that all bystanders have cleared the area.

Lubricate vertical knife push rods (A) after they are first installed and every 50 operating hours thereafter.

**NOTE:**

Use high-temperature extreme-pressure (EP2) performance lubricant with 1% max. molybdenum disulphide (NLGI Grade 2) lithium base to lubricate the vertical knives.

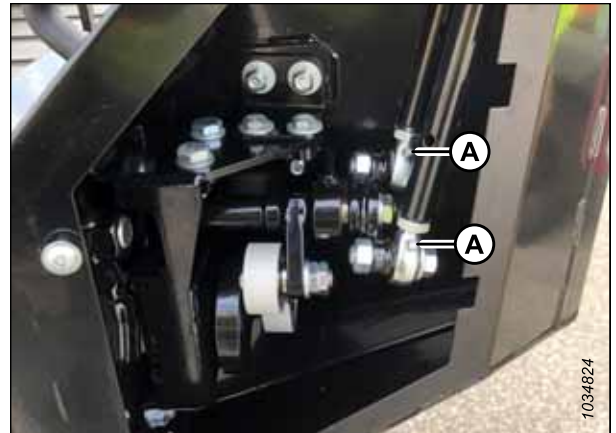


Figure 4.376: Grease Zerks on Vertical Knife Push Rods

To lubricate the vertical knife push rods, follow the steps below:

**NOTE:**

Some parts have been removed from the illustrations for clarity.

1. Lower the header to the ground.
2. Shut down the engine, and remove the key from the ignition.
3. Remove screws (A) and access cover (B).

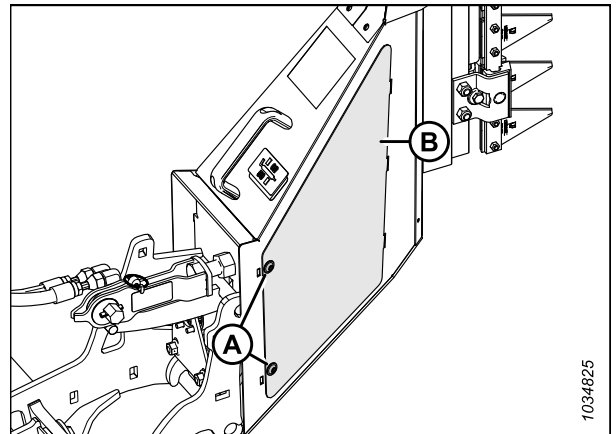


Figure 4.377: Vertical Knife Access Cover

4. Apply grease to push rod grease zerks (A).

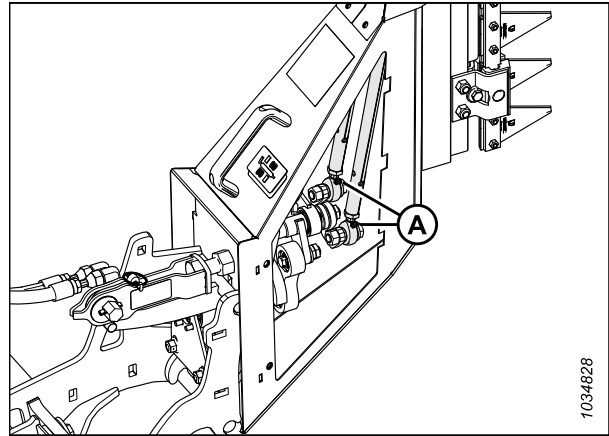


Figure 4.378: Grease Zerks on Vertical Knife Push Rods

5. Reinstall access cover (B).
6. Secure the access cover with screws (A).
7. Repeat Step 3, page 781 to Step 6, page 782 to lubricate the other vertical knife.

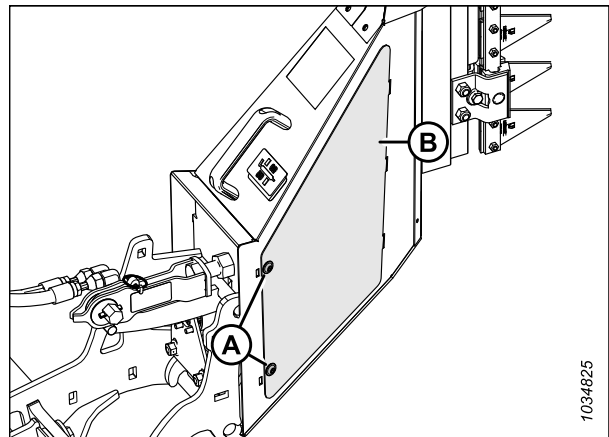


Figure 4.379: Vertical Knife Access Cover

### 4.17.3 Converting VertiBlade™ Knife Position

The VertiBlade™ vertical knife is delivered in a swathing position to protect it from damage. If this position is impractical, the knives can be lowered.

**NOTE:**

If the knives are lowered, they may be damaged if the header runs through drains or rocky patches.

**⚠ DANGER**

To prevent bodily injury or death from the unexpected start-up or fall of a raised machine, always stop the engine and remove the key before leaving the operator's seat, and always engage the safety props before going under the machine for any reason.

1. Shut down the engine, and remove the key from the ignition.



## MAINTENANCE AND SERVICING

2. Remove hardware (A). Retain the hardware.
3. Remove metal brackets (B) and (C).

**NOTE:**

There is an extra bracket (B) not shown in the illustration.

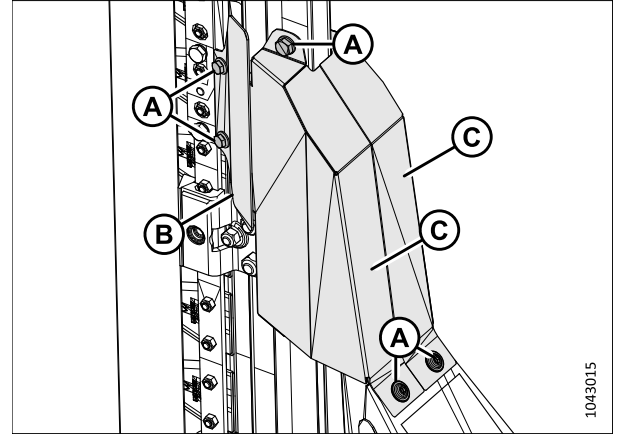


Figure 4.380: Removing Hardware Around Knife

4. Remove hardware (A) securing slide bars (B). Retain the hardware.
5. Remove and retain slide bars (B).
6. Remove hardware (C) securing knifehead (D) and knifehead (E). Retain the hardware.
7. Remove and retain knifehead (D) and knifehead (E).

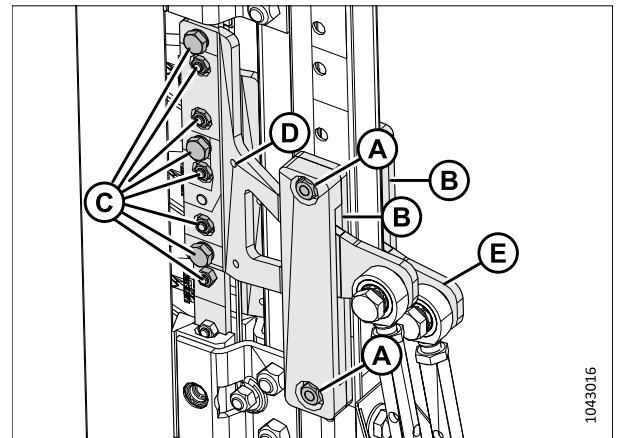


Figure 4.381: Removing Hardware Securing Knifeheads

8. Remove hardware (A) securing cover (B). Retain the hardware.
9. Remove cover (B).

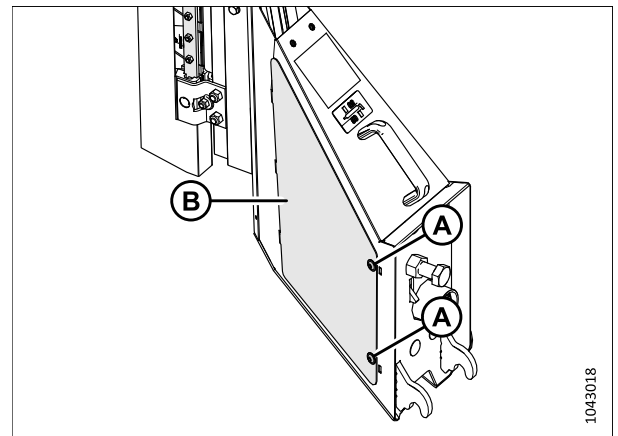


Figure 4.382: Removing Cover

## MAINTENANCE AND SERVICING

- Under the cover, remove bolts and washers (A). Retain the hardware.

**NOTE:**

Parts have been removed from the illustration for clarity.

- Apply medium-strength threadlocker (Loctite® 243 or equivalent) to the threads of the retained bolts.
- Slide knife (B) downward until you can reinstall bolts and washers (A) in holes (C) under the cover.
- Torque the bolts to 54 Nm (40 lbf-ft).

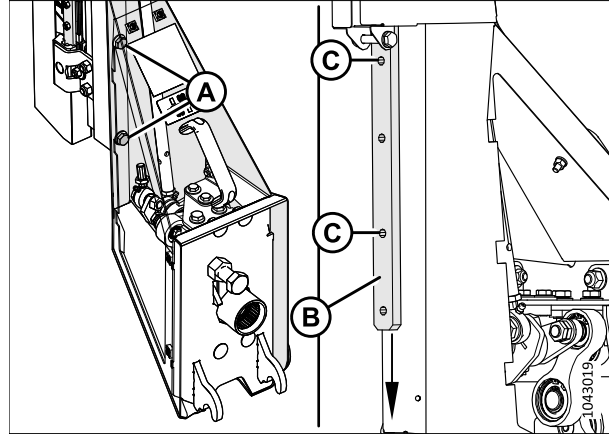


Figure 4.383: Adjusting Knife Position

- Reinstall cover (B).
- Reinstall hardware (A).
- Torque the hardware to 27 Nm (20 lbf-ft [240 lbf-in]).

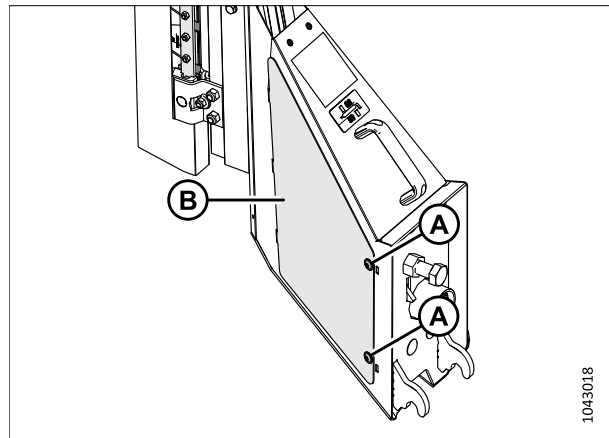


Figure 4.384: Reinstalling Cover

- Swap knifehead (D) and knifehead (E) from Step 7, page 783 and reinstall them upside-down to compensate for their new locations.

**NOTE:**

Parts have been removed from the illustration for clarity.

- Torque the hardware securing the knifeheads as follows:
  - Torque M6 bolts to 12 Nm (8.5 lbf-ft [102 lbf-in]).
  - Torque M8 bolts to 27 Nm (20 lbf-ft [240 lbf-in]).
  - Torque M10 bolts to 54 Nm (40 lbf-ft).

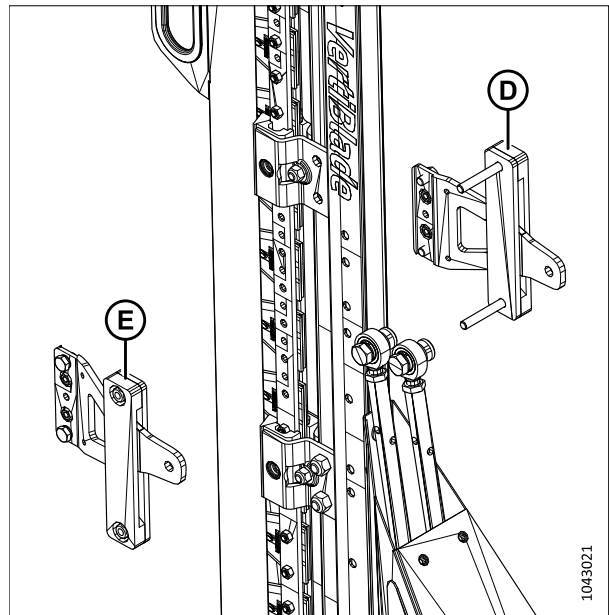


Figure 4.385: Reinstalling Knifeheads

## MAINTENANCE AND SERVICING

19. Reinstall metal brackets (A).
20. Reinstall hardware (B) and (C).
21. Tighten hardware (B) and (C) to 27 Nm (20 lbf-ft [240 lbf-in]).
22. Reinstall metal brackets (D).

**NOTE:**

There is an extra bracket (D) not shown in the illustration.

23. Reinstall hardware (E).
24. Tighten hardware (E) to 12 Nm (8.5 lbf-ft [102 lbf-in]).

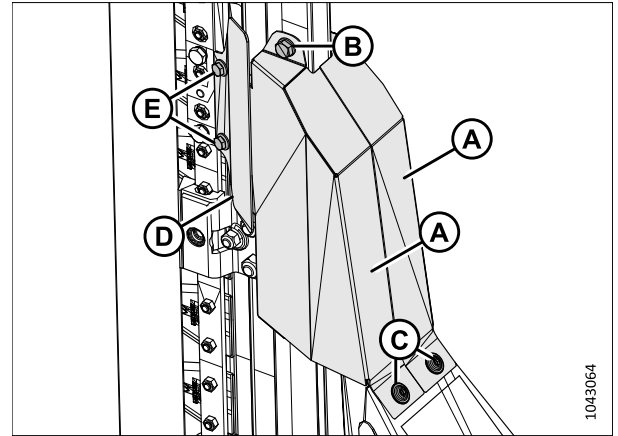


Figure 4.386: Reinstalling Hardware Around Knife

1043064



## Chapter 5: Options and Attachments

The following options and attachments are available for use with your header. See your Dealer for availability and ordering information.

### 5.1 Crop Delivery Kits

Crop delivery is the process of how the crop gets from the cutterbar to the feeder house. Optional crop delivery kits can optimize header performance for specific crops or conditions.

#### 5.1.1 Crop Lifter Kit

Crop lifters are recommended for the maximum possible stubble height (for example, when harvesting severely lodged cereal crops).

Installation instructions are included in the kit.

Each kit (B7022) contains 10 lifters. Order the following number of kits depending on your header's size:

- FD225 – 3 kits
- FD230 – 3 kits
- FD235 – 4 kits
- FD240 – 4 kits
- FD241 – 4 kits
- FD245 – 5 kits
- FD250 – 5 kits

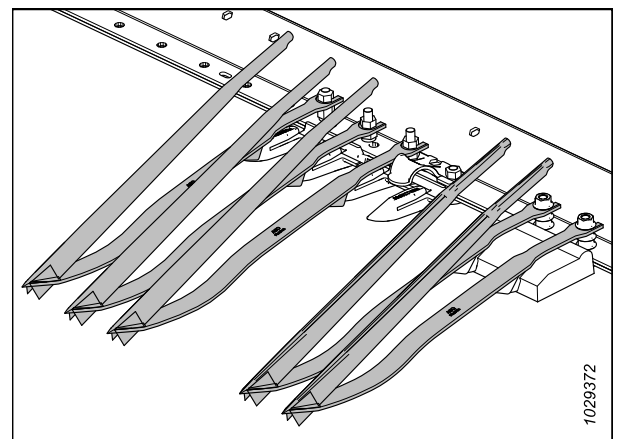


Figure 5.1: Grain Crop Lifter Kit

#### 5.1.2 Crop Lifter Storage Rack Kit

Crop lifter racks store crop lifters at the rear of the header.

Installation instructions are included in the kit.

B7023

**NOTE:**

This kit is for one side only. Order two kits for both sides of the header.

**NOTE:**

FD225 headers only need one kit.

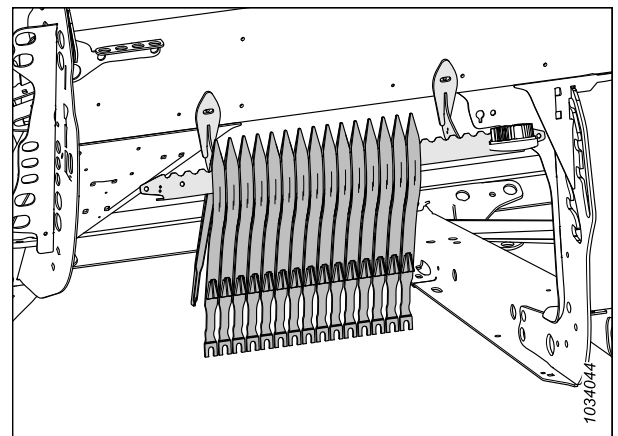


Figure 5.2: Crop Lifter Rack Kit – Left Side

### 5.1.3 Crop Divider Storage Bracket Kit

The crop divider storage bracket kit can store standard or floating crop dividers on the header.

Installation instructions are included in the kit.

B7030

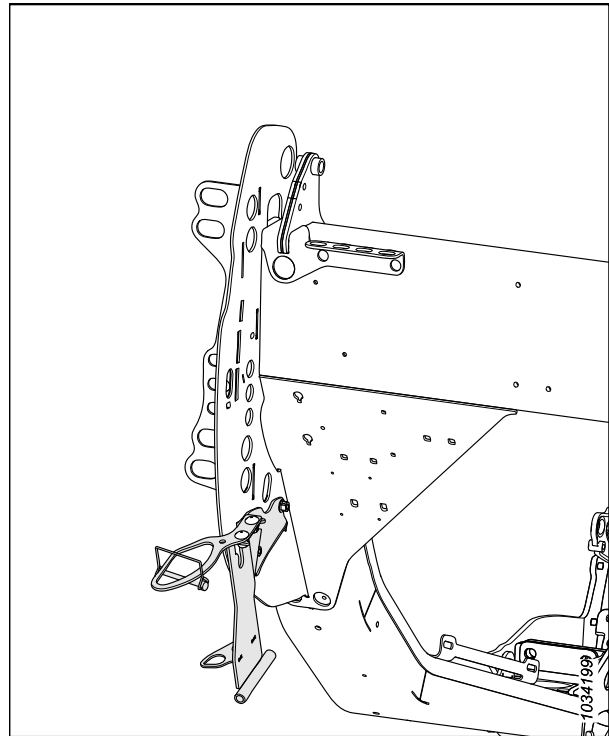


Figure 5.3: Divider Storage Bracket Kit

### 5.1.4 Floating Crop Dividers

Floating crop dividers help the header follow contours in the ground, improve crop dividing, and reduce trampling.

Installation instructions are included in the kit.

B7346

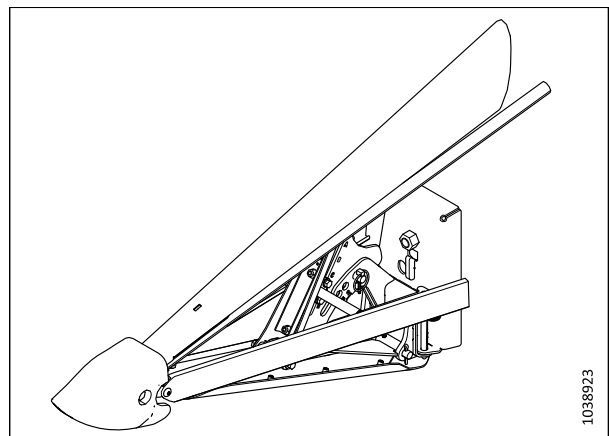


Figure 5.4: Floating Crop Divider

### 5.1.5 Full Length Upper Cross Auger

The upper cross auger (UCA) attaches to the header in front of the backtube and improves crop feeding to the center of the header in heavy crop conditions.

The upper cross auger (A) is ideal for the high-volume harvesting of forages, oats, canola, mustard, and other tall, bushy, hard-to-feed crops.

Order the following bundles:

**Base auger package**

Includes the auger, mounts, drive, and hydraulic completion plumbing for headers that are upper cross auger ready.

Order from the following list of kits according to your header size:

- FD225 – B6413 (two piece)
- FD230 – B6414 (two piece)
- FD235 – B6415 (two piece)
- FD240 – B6417 (three piece)
- FD241 – B6416 (two piece)
- FD245 – B6418 (three piece)
- FD250 – B6419 (three piece)

**Hydraulic Plumbing Package**

This package is only required for headers without factory-installed UCA hydraulics.

Order from the following list of kits according to your header size:

- FD225 – B7338 (two piece)
- FD230 – B7117 (two piece)
- FD235 – B7118 (two piece)
- FD240 – B7119 (three piece)
- FD241 – B7120 (two piece)
- FD245 – B7121 (three piece)
- FD250 – B7121 (three piece)

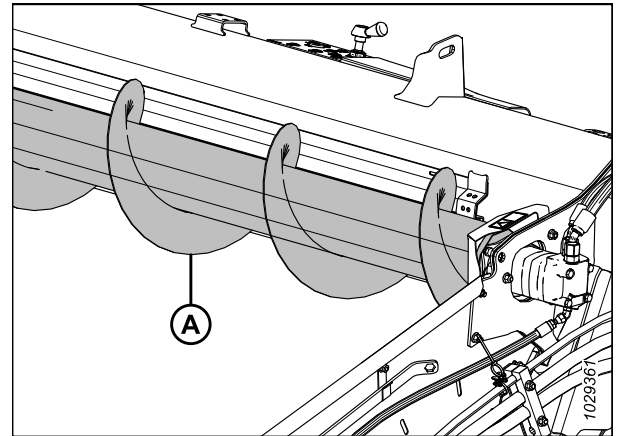


Figure 5.5: Upper Cross Auger

### 5.1.6 Lodged Crop Reel Finger Kit

The steel fingers attach to the ends of every other tine bar and help clear material in heavy, hard-to-cut crops such as lodged rice.

**NOTE:**

The Lodged Crop Reel Finger kit is not compatible with wide draper deflectors.

Each kit contains three fingers for the cam end and three fingers for the tail end of the reel. Hardware and installation and adjustment instructions are included with the kit.

B7230



Figure 5.6: Lodged Crop Finger

### 5.1.7 Rice Divider Rod Kit

Rice divider rods attach to the left and right crop dividers and divide tall and tangled rice crops in a similar manner to standard crop divider rods performing in standing crops.

The kit includes both left and right rods, and storage brackets.

B7238

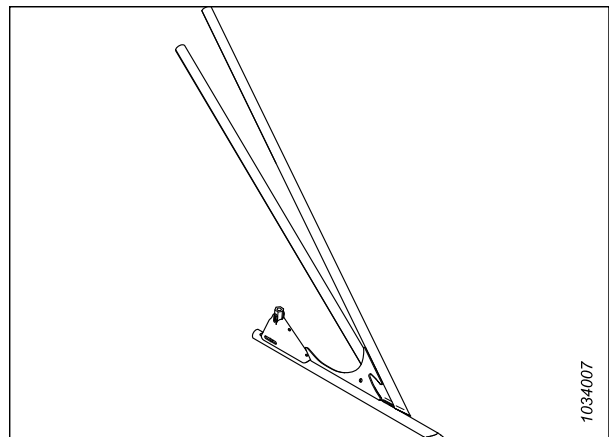
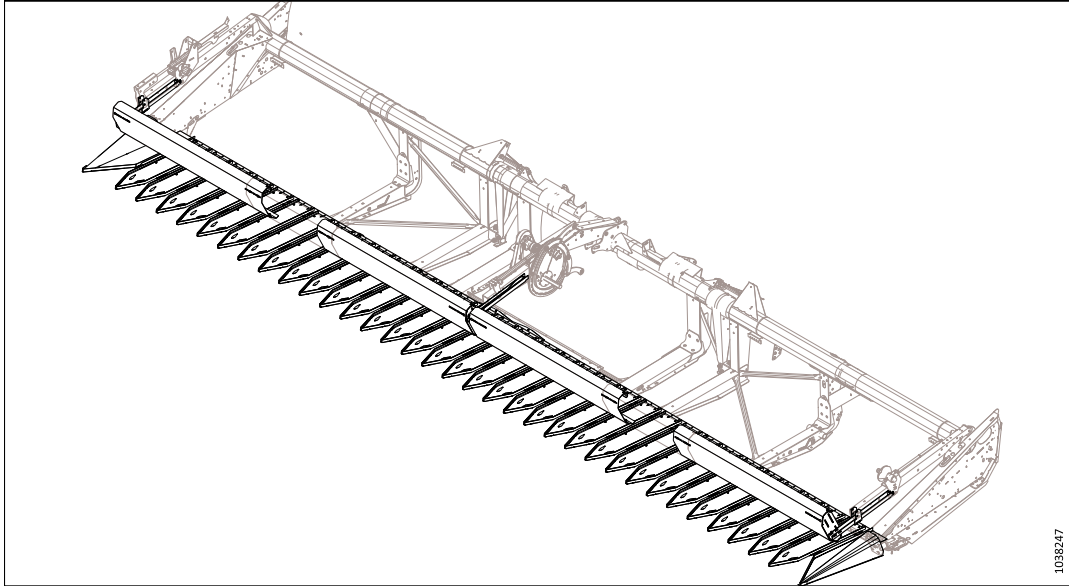


Figure 5.7: Left Rice Divider Rod Kit



### 5.1.8 Sunflower Attachment Kit

This kit allows the FD2 Series FlexDraper® Header (with pointed guards only) to be converted to a sunflower header.



**Figure 5.8: Sunflower Attachment**

Order the Sunflower Attachment Kit according to the size of the header:

- FD230 – C2086
- FD235 – C2087
- FD240 triple reel – C2169
- FD240 double reel – C2088
- FD241 double reel – C2088
- FD245 – C2089
- FD250 – C2170

The collectors contain a base kit, pan kits, and deflectors.

**Base Kit (B7302)** – contains common brackets, end dividers, cutterbar pan supports, lean bar components, and hardware.

**Pan Kit (B7303)** – contains five pans per kit (including two spares). Order the number of pan kits according to the size of the header:

- FD230 – 0 kits<sup>96</sup>
- FD235 – 1 kit
- FD240 – 2 kits
- FD241 – 2 kits
- FD245 – 3 kits
- FD250 – 4 kits

96. The base kit contains enough pans for FD230 headers. No additional pan kits are required.

## OPTIONS AND ATTACHMENTS

**Deflectors** – contain lean bar panels and additional cutterbar pan supports:

- FD230 – B7304
- FD235 – B7305
- FD240 triple reel – B7395
- FD240 double reel – B7306
- FD241 double reel – B7306
- FD245 – B7307
- FD250 – B7396

### 5.1.9 End Deflector Rods

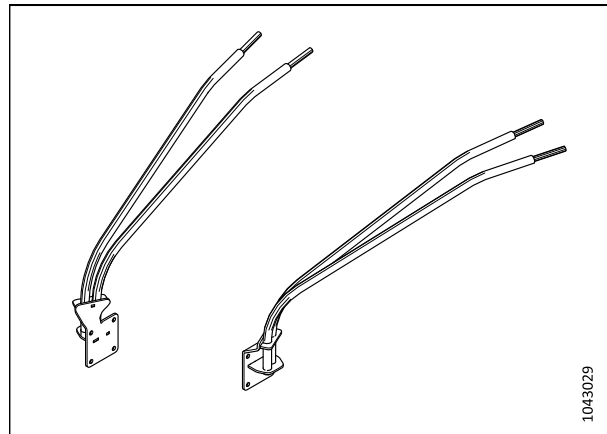
Deflector rods help prevent delivered crop at the opening from interfering with standing crop.

**NOTE:**

End deflector rods are used for double-swathing with end delivery only.

There is a kit for the left side of the header (B6447) and a kit for the right side of the header (B6448).

Installation and adjustment instructions are included with each kit.



**Figure 5.9: End Deflector Rods**

### 5.1.10 VertiBlade™ Vertical Knife Kit

The VertiBlade™ Vertical Knife is a vertical crop cutter that is mounted to each end of the header. It is used to cut through lodged or tangled crops.

Order the following bundles:

**Base VertiBlade™ Kit**

Includes the knives, mounts, drive, and hydraulic completion plumbing to complete installation on a power-divider ready header.

B7029

**Hydraulic Plumbing Package**

The hydraulic plumbing packages are required only for headers without factory-installed power divider hydraulics. The package includes the hydraulic lines to make a header power-divider (VertiBlade™) ready.

Order one of the following kits based on your header size:

- FD225 – B7339
- FD230 – B7127
- FD235 – B7128
- FD240 – B7129
- FD241 – B7130
- FD245 – B7195
- FD250 – B7131

Installation instructions are included in the kits.

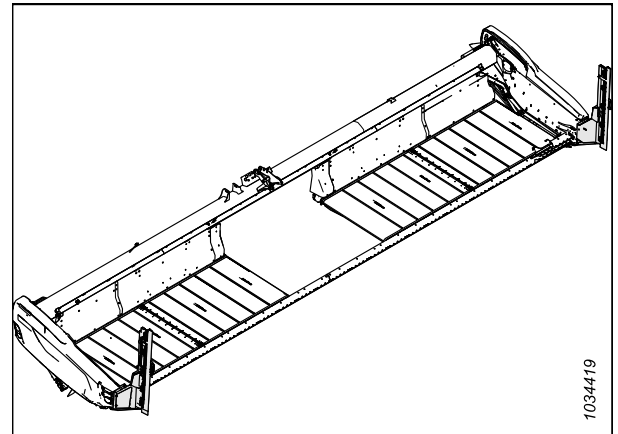


Figure 5.10: VertiBlade™ Vertical Knife Kit

## 5.2 Cutterbar Kits

The cutterbar is located on the front of the header. It supports the knife and the guards, which together, are used to cut the crop.

### 5.2.1 Rock Retarder Kit

A rock retarder extends the height of the cutterbar lip to help prevent rocks from rolling onto the draper decks.

Order bundles by header size:

- FD225, FD230, FD235, and FD241 – B7122
- FD240, FD245, and FD250 – B7123

Installation instructions are included in the kits.

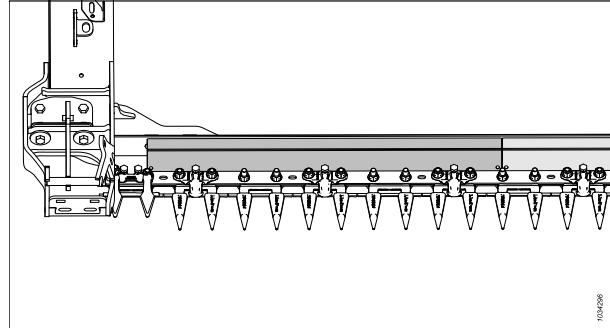


Figure 5.11: Rock Retarder Kit

### 5.2.2 Four-Point Knife Guard

Four-point guards provide increased knife protection in very rocky conditions, and can improve header performance with shatter-prone crops by reducing side-to-side crop motion.

Four-point knife guard kits are available for all FD2 Series FlexDraper® Headers. Refer to the header parts catalog or contact your Dealer for part numbers.

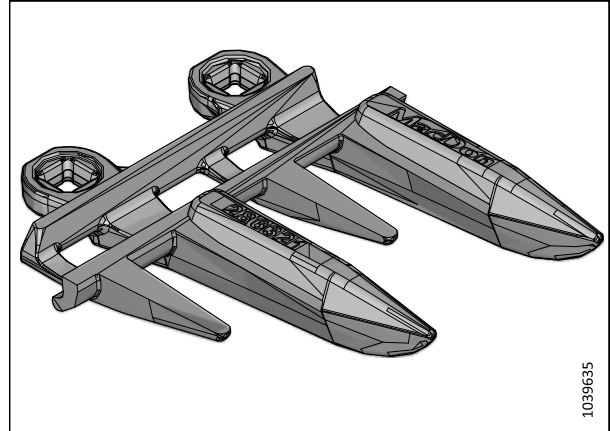


Figure 5.12: Four-Point Knife Guard

## 5.3 FM200 Float Module Kits

The float module is used to attach the header to the combine. It combines the crop flow from both side drapers and also pulls crop into the combine feeder house.

### 5.3.1 10 V Sensor Adapter Kit

This kit is for New Holland CR/CX combines that use 10 V sensors. The module converts combine 10 V supply to 5 V for the header, the signal then gets converted from low header voltage to higher combine voltage.

B7241

This adapter is for the following New Holland CR/CX combines:

- All CX800/CX8000/CX900 combines
- CR9040/CR9060 combines before serial number HAJ111000
- CR9070 combines before serial number Y8G1412000

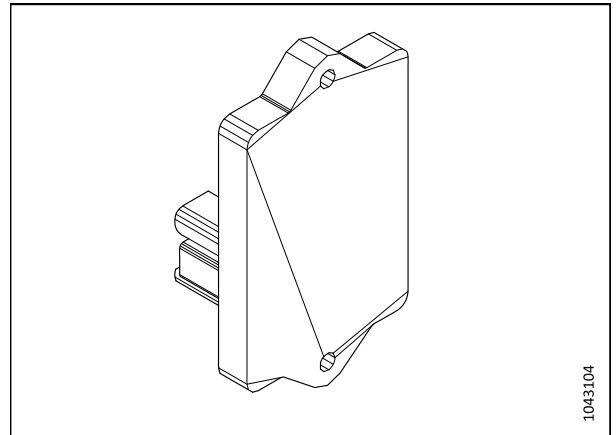


Figure 5.13: 10 V Sensor Adapter

### 5.3.2 Crop Deflector Kits

This kit includes different sizes of crop deflectors to be installed on the float module depending on the size of the feeder house.

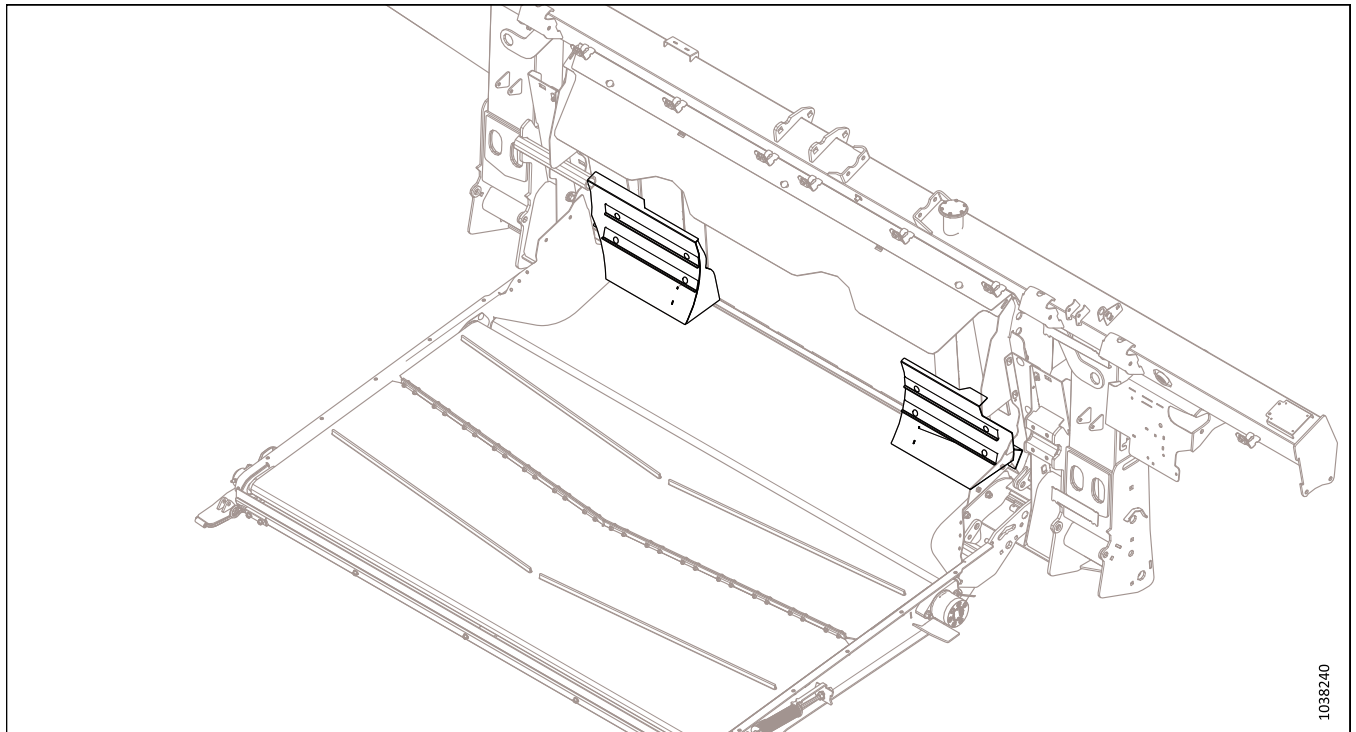


Figure 5.14: Crop Deflectors

## OPTIONS AND ATTACHMENTS

Refer to the table below to determine which deflector kit to order:

Combine Feeder House Size	Kit
Ultra Narrow	B7314
Narrow	B7347
Medium	B7348

### 5.3.3 Extended Center Filler

The Extended Center Filler kit includes a wider filler plate to seal the area behind the transition pan, reducing loss when cutting crops like beans and peas.

Installation instructions are included in the kit.

B6450

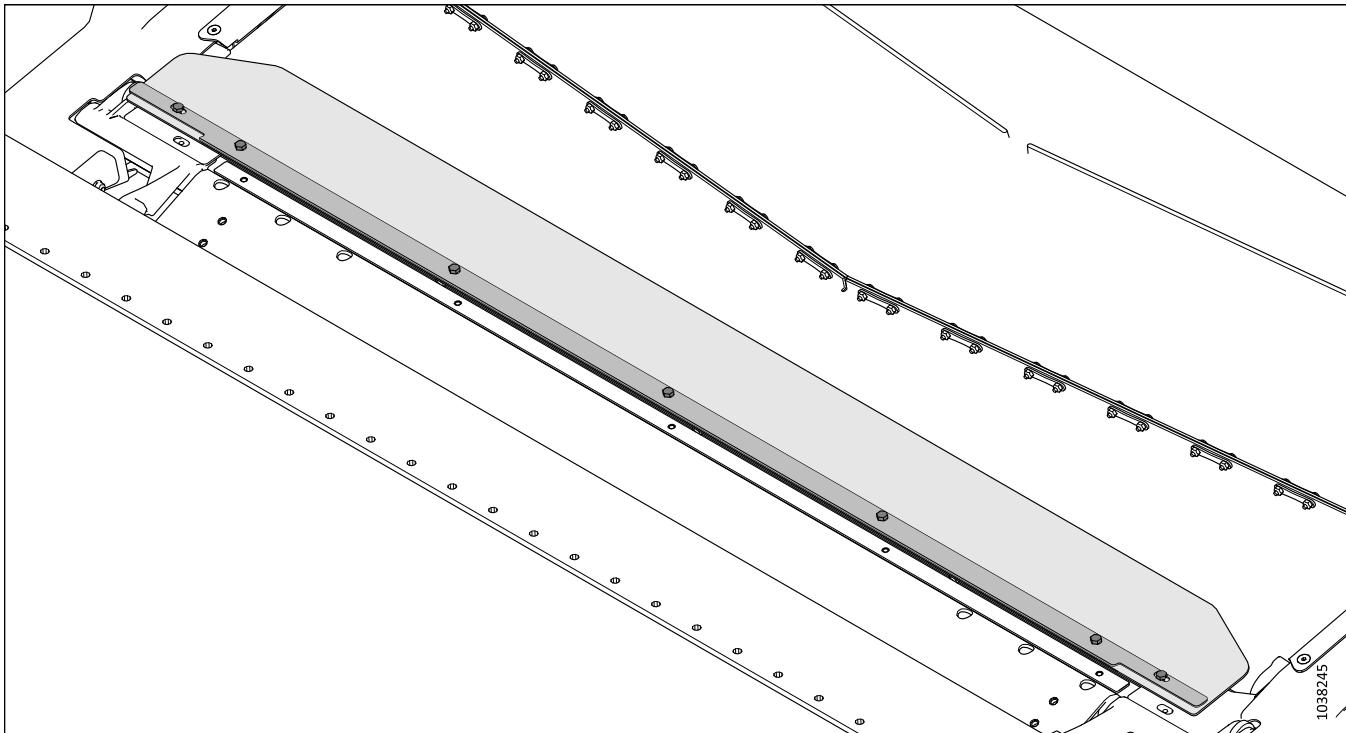


Figure 5.15: Extended Center Filler

### 5.3.4 Feed Auger High-Wear Flighting Extension Kit

The flighting extension kit improves the feed of crop in green/wet straw conditions (for example, rice and green cereals).

Refer to [3.8.1 FM200 Feed Auger Performance Configurations, page 158](#) for a list of possible flighting combinations.

B6400

Installation instructions are included in the kit.

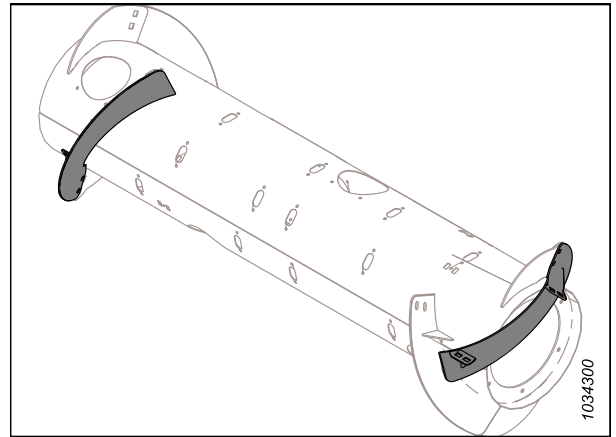


Figure 5.16: Feed Auger High-Wear Flighting Extension Kit

### 5.3.5 Full Interface Filler Kit

The Full Interface Filler kit provides additional sealing between the float module and the header.

**NOTE:**

This kit is only available for European-configured headers.

Installation instructions are included in the kit.

B7217

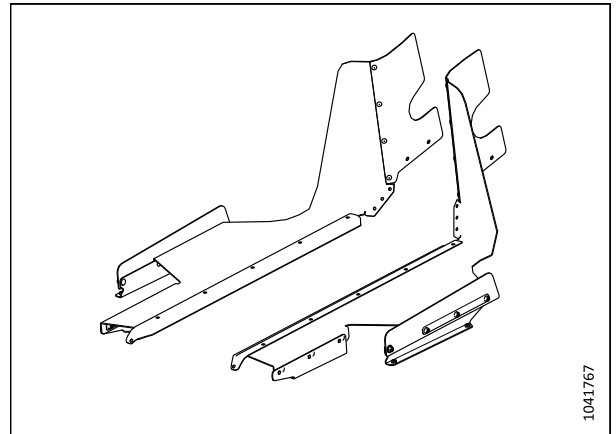


Figure 5.17: Full Interface Filler Kit

### 5.3.6 Hydraulic Reservoir Extension Kit

The Hydraulic Reservoir Extension kit extends the breather cap position, allowing the float module to operate on steep hillsides while maintaining oil supply to the suction side of the pump.

This kit is recommended when operating on hills exceeding 5°.

B7542

Installation instructions are included in the kit.

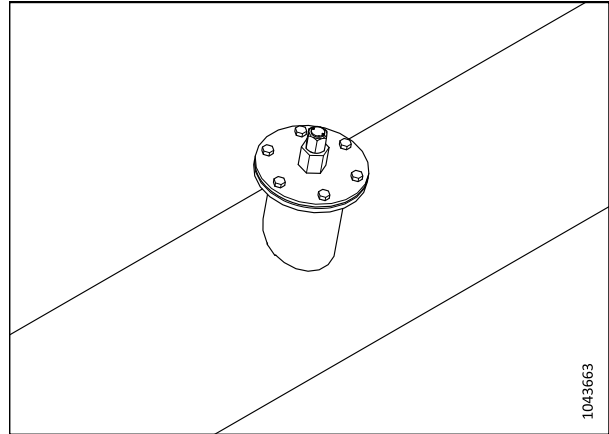


Figure 5.18: Hydraulic Reservoir Extension Kit

### 5.3.7 Auto Header Height and Tilt Plug Kits

These kits modify the FM200 Float Module’s auto header height control. Depending on how the combine is configured, you may need to interchange these plugs.

- **B7196 (Lateral Tilt Plug):** This plug sends the combine signals from the left and right sensors and averages the two signals for any center signals required.
- **B7489 (Auto Header Height Plug):** This plug sends the combine one average center signal.
- **B7490 (Pass-through Plug):** This plug sends the combine two distinct signals from the left and right sensors. It does not average the signals.

Installation instructions are included in the kits.

**NOTE:**

The Lateral Tilt Plug kit is not recommended for slopes that are over 10% grade.

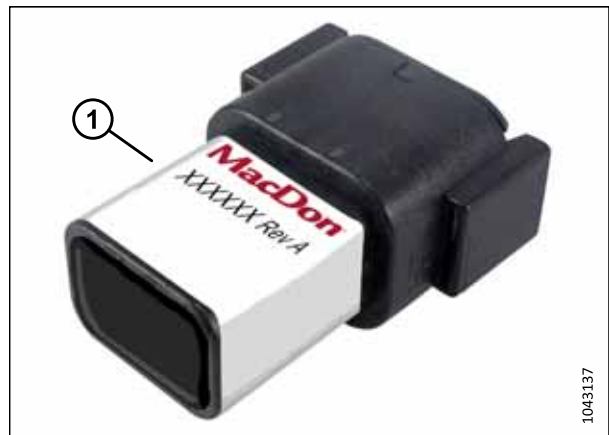


Figure 5.19: Float Plug



### 5.3.8 Stripper Bars Kit

Stripper bars improve feeding for certain crops such as rice. They are **NOT** recommended for cereal crops.

Select the stripper bars kit based on the width of the combine feeder house. For more information, refer to Table 5.1, page 799.

Installation instructions are included in the kits.

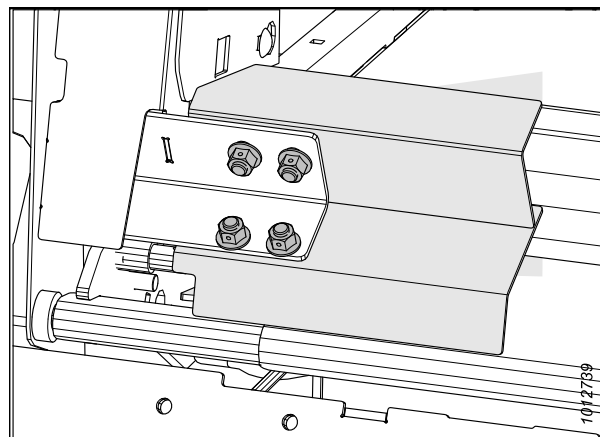


Figure 5.20: Stripper Bar

Table 5.1 Stripper Bar Configurations and Recommendations

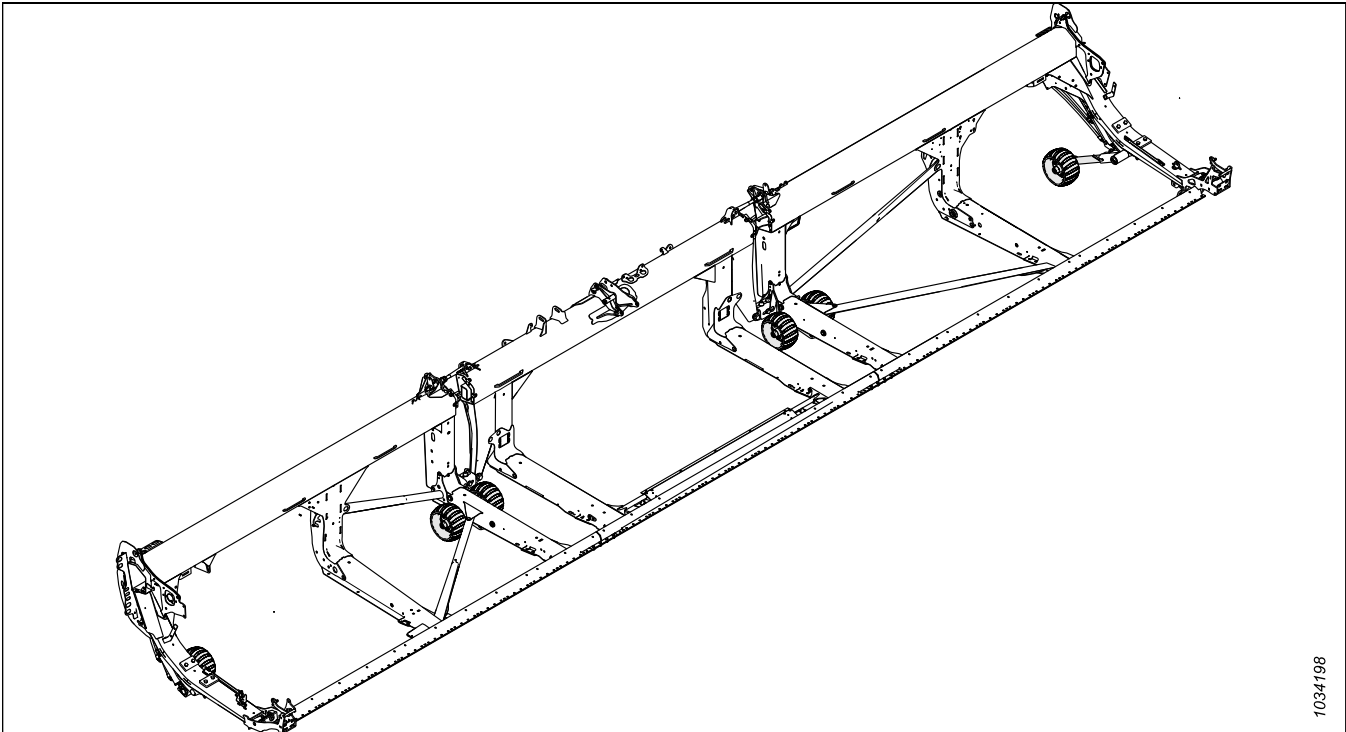
Kit	Stripper Bar Length	Opening Width Float Module	Recommended Feeder House Width
B6042	265 mm (10 1/2 in.)	1317 mm (52 in.)	1250–1350 mm (49–65 in.)
B6043	265 mm (10 1/2 in.) (with cutout)	1317 mm (52 in.)	For John Deere S Series only
B6044	325 mm (13 in.)	1197 mm (47 in.)	For specialty crops only
B6045	365 mm (14 1/2 in.)	1117 mm (44 in.)	1100 mm (43 1/2 in.) and below
B6046	403 mm (16 in.)	1041 mm (41 in.)	For specialty crops only
B6213	515 mm (20 in.)	817 mm (32 in.)	For specialty crops only

## 5.4 Header Kits

Header kits add features or enhancements to the header.

### 5.4.1 ContourMax™ Contour Wheels Kit

The ContourMax™ provides flex and auto header height control (AHHC) for stubble heights of 25–457 mm (1–18 in.) (standard header provides 0–152 mm [0–6 in.]



**Figure 5.21: ContourMax™ Contour Wheels**

The kit consists of four wheel sets and hydraulic height adjustment from inside the combine cab. Installation instructions are included in the kit. Order the following bundles:

**Base ContourMax™ Package:** Includes wheels, mounts, cylinders, a control valve, and hydraulic plumbing to complete installation on a ContourMax™ ready header.

B7335

**Hydraulic Plumbing Package:** Includes hydraulic lines to prepare the header for ContourMax™ if it is not factory configured. Order the hydraulic plumbing package from the following list according to your header model:

- FD225 – B7340
- FD230 – B7082
- FD235 – B7083
- FD240 – B7113
- FD241 – B7114
- FD245 – B7193
- FD250 – B7116

### 5.4.2 ContourMax™ Foot Switch Kit

The ContourMax™ foot switch allows you to change the position of the ContourMax™ without taking your hand off the multifunction handle.

This option is available for John Deere and AGCO (Challenger®, Fendt®, Gleaner®, and Massey Ferguson®) combines.

B7040

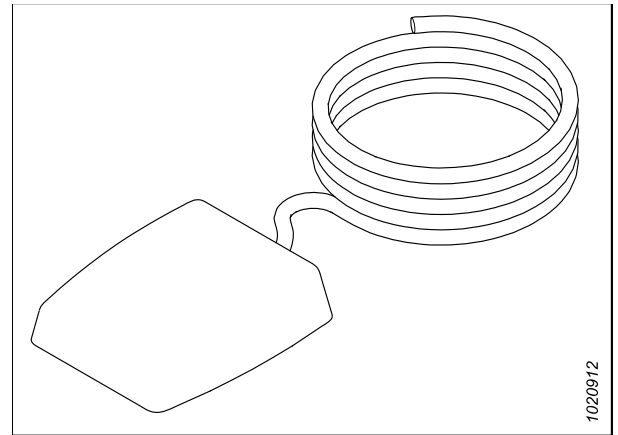


Figure 5.22: ContourMax™ Foot Switch

### 5.4.3 EasyMove™ Transport System

The EasyMove™ Transport System makes it faster than ever to move your header from field to field. When operating in the field, the wheels can also be used as stabilizer wheels.

Installation instructions are included in the kit.

To install this kit, order one of the following according to the size of the header:

- FD230 – C2172
- FD235 – C2260
- FD240 – C2173
- FD241 – C2173
- FD245 – C2173
- FD250 – C2173

C2172 consists of

- Stabilizer Wheels / EasyMove™ Transport Base Kit – B6288
- Wheels and Tires – B7398
- Short Tow Pole – B7391

C2260 consists of

- Stabilizer Wheels / EasyMove™ Transport Base Kit – B6288
- Wheels and Tires – B7398
- Medium Tow Pole – B7548

C2173 consists of

- Stabilizer Wheels / EasyMove™ Transport Base Kit – B6288
- Wheels and Tires – B7398
- Long Tow Pole – B7392

**NOTE:**

The EasyMove™ Transport System is **NOT** compatible with FD225 headers.

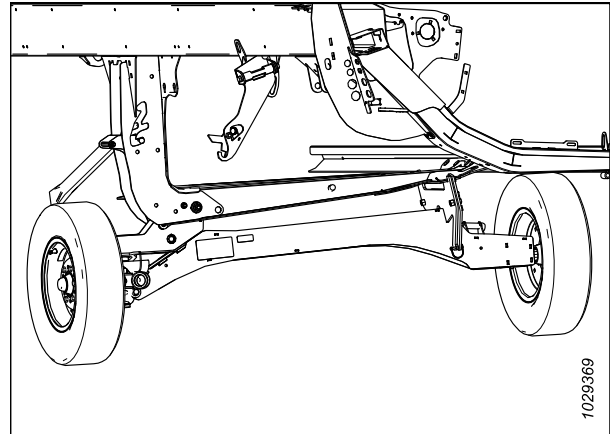


Figure 5.23: EasyMove™ Transport System

### 5.4.4 Inboard Steel End Finger Kit

Optional fingers to be used in difficult crops, lodged canola, and forage, where the angled plastic finger yields and distorts from heavy crop loads.

Installation instructions are included in the kit.

MD #311972

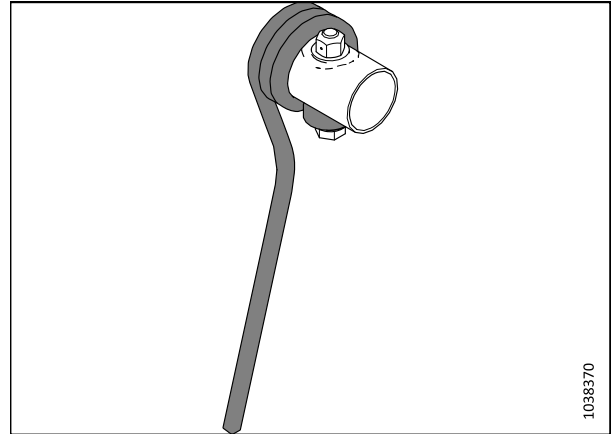


Figure 5.24: Inboard Steel End Finger

### 5.4.5 Outboard Steel End Finger Kit

Optional fingers to be used in difficult crops such as lodged canola, and forage, where the angled plastic finger yields and distorts from heavy crop loads.

Installation instructions are included in the kit.

MD #311959

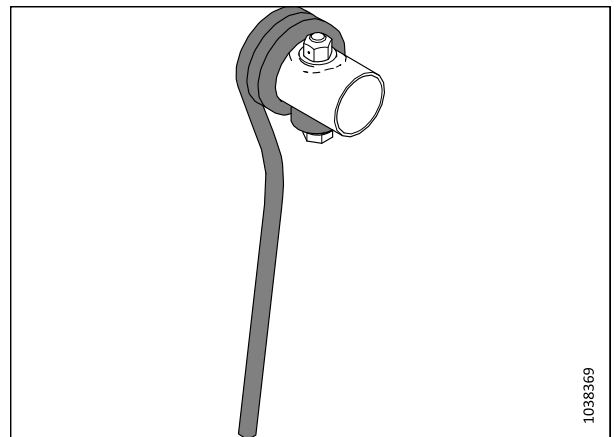


Figure 5.25: Outboard Steel End Finger

### 5.4.6 Plastic Reel Finger Kit

Order one of the following based on your header size:

- FD225, Single Reel, 6 bat to 9 bat – B7361
- FD230, Double Reel, 6 bat to 9 bat – B7362
- FD241, Double Reel, 5 bat to 6 bat – B7359

For installation instructions, refer to *Installing Plastic Reel Fingers*, page 731.

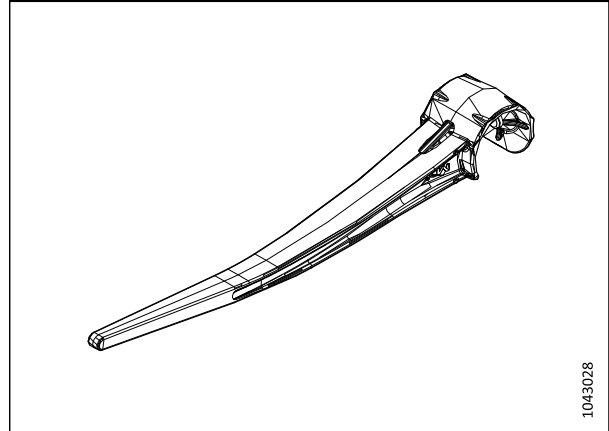


Figure 5.26: Plastic Reel Finger

### 5.4.7 Steel Reel Finger Kit

Optional fingers to be used in difficult crops, lodged canola, and/or forage.

Order one of the following based on your header size:

- FD225, Single Reel, 6 bat – MD #360679
- FD225, Single Reel, 9 bat – MD #360680
- FD230, Double Reel, 5 bat – MD #311054
- FD230, Double Reel, 6 bat – MD #311055
- FD235, Double Reel, 5 bat – 311068
- FD235, Double Reel, 6 bat – MD #311069

Installation instructions are included in the kit.

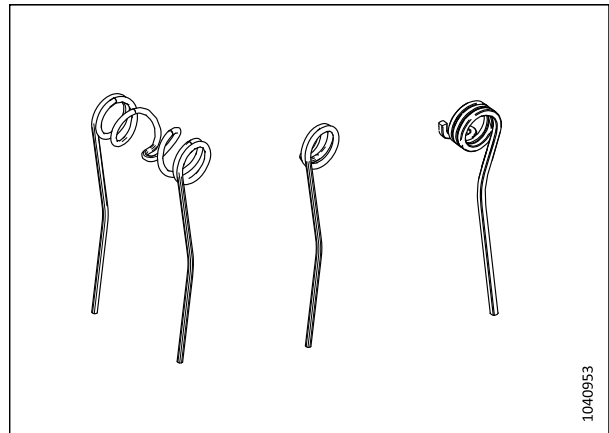


Figure 5.27: Steel Reel Finger

### 5.4.8 Side Hill Stabilizer Kit

The Side Hill Stabilizer kit is recommended for cutting on side hills with a grade steeper than 5°.

Installation instructions are included in the kit.

B7028

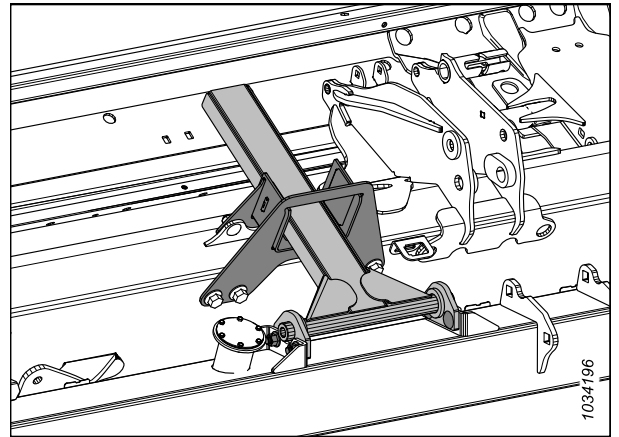


Figure 5.28: Side Hill Stabilizer Kit

### 5.4.9 Stabilizer Wheel Kit

Stabilizer wheels stabilize the header's lateral movement when cutting at heights higher than possible with the standard skid shoes.

Installation and adjustment instructions are included in the kit.

C2171

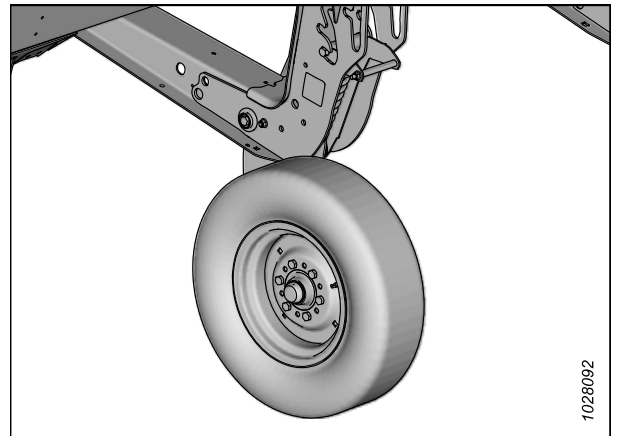


Figure 5.29: Stabilizer Wheel Kit

### 5.4.10 Steel Skid Shoes Kit

This kit provides extended-wear skid shoes for use in rocky, abrasive conditions.

**IMPORTANT:**

This kit is not recommended for use in wet mud or conditions that are prone to sparking.

The kit contains two skid shoes. To fully replace a set of standard skid shoes, order three bundles (for six shoes total).

B6801

Installation instructions are included in the kit.

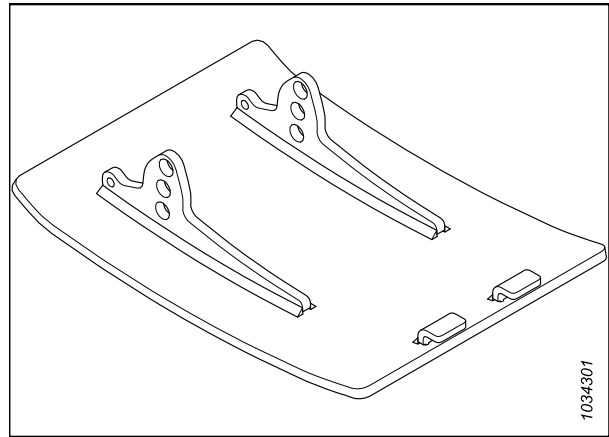


Figure 5.30: Steel Skid Shoes Kit

### 5.4.11 Stubble Light Kit

Stubble lights are used in low light conditions and allow you to see the stubble cut behind the header. The Stubble Light kit is available for FD225, FD230, FD235, FD241, and FD245 FlexDraper® Headers. This kit is currently compatible with John Deere, Case, and New Holland combines with the necessary software. For details on the compatibility of Case and New Holland combines, refer to Table 5.2, page 807<sup>97</sup>.

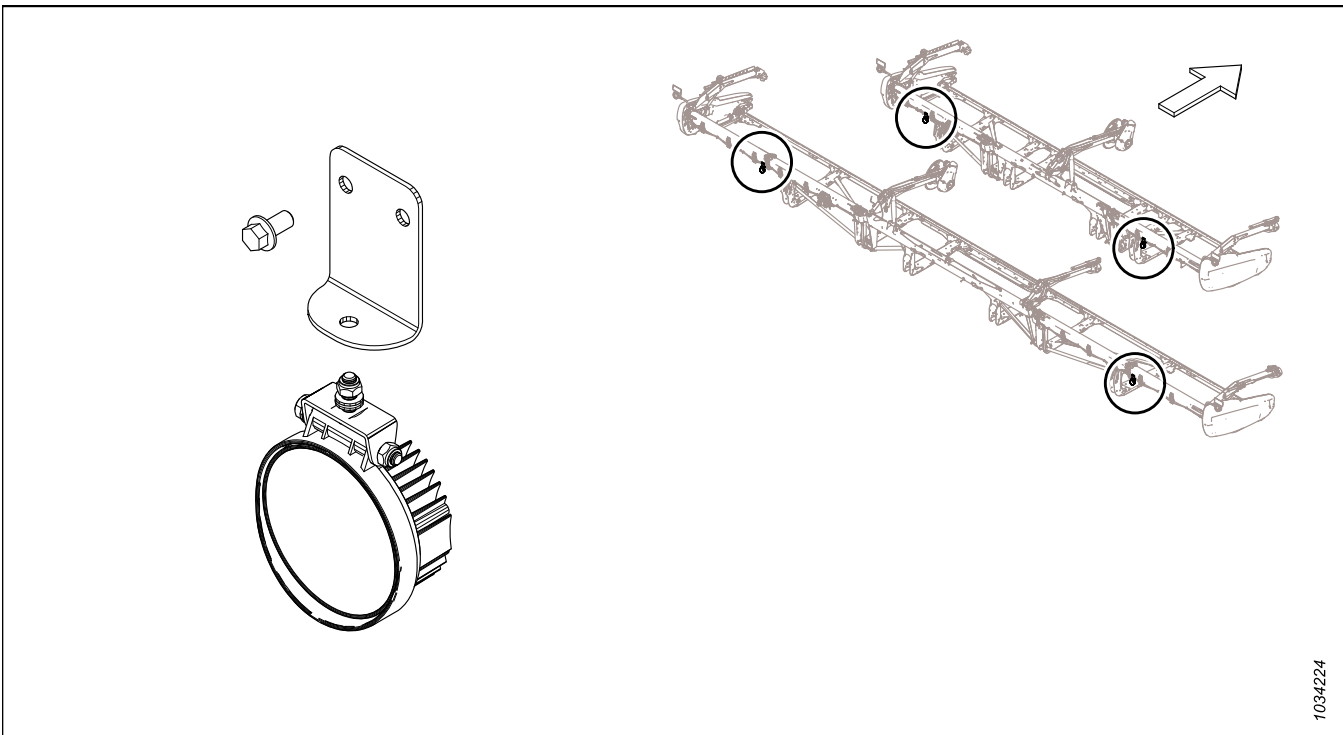


Figure 5.31: Stubble Light Kit

97. If your combine is compatible, a software update may be necessary.



## OPTIONS AND ATTACHMENTS

**Table 5.2 Compatibility Table**

<b>Model<sup>98</sup></b>	<b>Model Year</b>
Case IH – 7250/8250/9250	2019 and later
Case IH Mid-Range – 6160/7160	2024 and later
New Holland CR – 8.90, 9.80, 9.90, 10.90	2019 and later
New Holland CX – 8.80/8.90	2020 and later

Installation instructions are included with the kit.

B7027

---

98. If your combine is compatible, a software update may be necessary.



## Chapter 6: Troubleshooting

Troubleshooting tables are provided to help you diagnose and solve any problems you may have with the header.

### 6.1 Crop Loss at Cutterbar

Use the following tables to determine the cause of crop loss at the cutterbar and the recommended solution.

**Table 6.1 Troubleshooting – Crop Loss at Cutterbar**

Problem	Solution	Refer to
<b>Symptom: The header is not picking up downed crop</b>		
Cutterbar too high	Lower the cutterbar	<ul style="list-style-type: none"> <li>3.9.1 Cutting off Ground, page 189</li> <li>3.9.2 Cutting on Ground, page 207</li> </ul>
Header angle too low	Increase the header angle	3.9.5 Header Angle, page 232
Reel too high	Lower the reel	3.9.11 Reel Height, page 247
Reel too far back	Move the reel forward	3.9.12 Reel Fore-Aft Position, page 252
Ground speed too fast for reel speed	Increase the reel speed or reduce the ground speed	<ul style="list-style-type: none"> <li>3.9.6 Reel Speed, page 240</li> <li>3.9.7 Ground Speed, page 242</li> </ul>
Reel fingers not lifting crop sufficiently	Increase the finger pitch aggressiveness	3.9.13 Reel Tine Pitch, page 261
Reel fingers not lifting crop sufficiently	Install crop lifters	Dealer
<b>Symptom: Heads are shattering or breaking off</b>		
Reel speed too fast	Reduce the reel speed	3.9.6 Reel Speed, page 240
Reel too low	Raise the reel	3.9.11 Reel Height, page 247
Ground speed too fast	Reduce the ground speed	3.9.7 Ground Speed, page 242
Crop too ripe	Work at night when the humidity is higher	—
<b>Symptom: Material accumulating between the endsheet and the knifehead</b>		
Crop heads leaning away from knifehead hole in endsheet	Add knifehead shields (except in damp or sticky soils)	4.8.7 Knifehead Shield, page 664
<b>Symptom: Material is not being cut</b>		
Guards plugged with debris	Install short knife guards	4.8.6 Short Knife Guards and Hold-Downs, page 652
Broken knife sections	Replace the broken sections	4.8.1 Replacing Knife Section, page 629
<b>Symptom: Excessive bouncing at normal field speed</b>		
Float set too light	Adjust the header float	3.9.3 Header Float, page 209
<b>Symptom: Divider rod running down standing crop</b>		
Divider rods too long	Remove divider rods	3.9.15 Crop Dividers, page 268
<b>Symptom: Crop is not being cut at ends</b>		
Reel not frowning or not centered in header	Adjust the reel horizontal position or the reel frown	3.9.12 Reel Fore-Aft Position, page 252

## TROUBLESHOOTING

**Table 6.1 Troubleshooting – Crop Loss at Cutterbar (continued)**

Problem	Solution	Refer to
Knife hold-down not adjusted properly	Adjust the hold-down so that the knife works freely but still keeps sections from lifting off of the guards	<ul style="list-style-type: none"> <li>• <i>Adjusting Hold-Down – Pointed Knife Guards, page 646</i></li> <li>• <i>Adjusting Hold-Down – Short Knife Guards, page 659</i></li> </ul>
Knife sections or guards are worn or broken	Replace all of the worn and broken cutting parts	<i>4.8 Knife, page 629</i>
Header is not level	Level the header	Dealer
Reel fingers not lifting crop properly ahead of knife	Adjust the reel position and/or the finger pitch	<ul style="list-style-type: none"> <li>• <i>3.9.12 Reel Fore-Aft Position, page 252</i></li> <li>• <i>3.9.13 Reel Tine Pitch, page 261</i></li> </ul>
Divider runs down thick crop at the ends, preventing proper feeding due to the material bridging the guards	Replace 3–4 end guards with short knife guard	<ul style="list-style-type: none"> <li>• <i>4.8.6 Short Knife Guards and Hold-Downs, page 652</i></li> <li>• Dealer</li> </ul>
<b>Symptom: Crop flows over divider rods and builds up on the endsheets</b>		
Divider rods providing insufficient separation	Install long divider rods	<i>3.9.15 Crop Dividers, page 268</i>
<b>Symptom: Cut grain falls ahead of the cutterbar</b>		
Ground speed too slow	Increase the ground speed	<i>3.9.7 Ground Speed, page 242</i>
Reel speed too slow	Increase the reel speed	<i>3.9.6 Reel Speed, page 240</i>
Reel too high	Lower the reel	<i>3.9.11 Reel Height, page 247</i>
Cutterbar too high	Lower the cutterbar	<ul style="list-style-type: none"> <li>• <i>3.9.1 Cutting off Ground, page 189</i></li> <li>• <i>3.9.2 Cutting on Ground, page 207</i></li> </ul>
Reel too far forward	Move the reel back on the arms	<i>3.9.12 Reel Fore-Aft Position, page 252</i>
Cutting at speeds over 10 km/h (6 mph) with 10-tooth reel drive sprocket	Replace the reel drive sprocket with a 19-tooth reel drive sprocket	<ul style="list-style-type: none"> <li>• <i>Removing Reel Drive Single Sprocket, page 752</i></li> <li>• <i>Removing Reel Drive Optional Dual Sprocket, page 753</i></li> <li>• <i>4.14.2 Reel Drive Sprocket, page 752</i></li> </ul>
Worn or broken knife components	Replace the components	<i>4.8 Knife, page 629</i>

## 6.2 Cutting Action and Knife Components

Use the following table to determine the cause of the cutting action and knife component problems and the recommended repair procedure.

**Table 6.2 Troubleshooting – Cutting Action and Knife Components**

Problem	Solution	Refer to
<b>Symptom: Ragged or uneven cutting of crop</b>		
Knife hold-down not adjusted properly	Adjust the hold-down	<ul style="list-style-type: none"> <li>• <i>Adjusting Hold-Down – Pointed Knife Guards, page 646</i></li> <li>• <i>Adjusting Hold-Down – Short Knife Guards, page 659</i></li> </ul>
Knife sections or guards are worn or broken	Replace all worn and broken cutting parts	<ul style="list-style-type: none"> <li>• <i>Replacing Pointed Knife Guards, page 643</i></li> <li>• <i>Replacing Pointed Center Knife Guard – Double-Knife Header, page 647</i></li> <li>• <i>Replacing Short Knife Guards or End Knife Guards, page 656</i></li> <li>• <i>Replacing Center Knife Guard – Double-Knife Headers, page 660</i></li> <li>• <i>4.8.1 Replacing Knife Section, page 629</i></li> </ul>
Ground speed too fast for reel speed	Reduce the ground speed or increase the reel speed	<ul style="list-style-type: none"> <li>• <i>3.9.6 Reel Speed, page 240</i></li> <li>• <i>3.9.7 Ground Speed, page 242</i></li> </ul>
Reel fingers not lifting crop properly ahead of knife	Adjust the reel position/ finger pitch	<ul style="list-style-type: none"> <li>• <i>3.9.12 Reel Fore-Aft Position, page 252</i></li> <li>• <i>3.9.13 Reel Tine Pitch, page 261</i></li> </ul>
Cutterbar too high	Lower the cutting height	<i>3.9.1 Cutting off Ground, page 1893.9.2 Cutting on Ground, page 207</i>
Header angle too flat	Steepen the header angle	<i>3.9.5 Header Angle, page 232</i>
Cutting edge of guards not close enough or parallel to knife sections	Align the guards	<i>Adjusting Knife Guards and Guard Bar, page 641</i>
Tangled/tough-to-cut crop	Install short knife guards	<ul style="list-style-type: none"> <li>• Dealer</li> <li>• <i>Adjusting Hold-Down – Pointed Knife Guards, page 646</i></li> <li>• <i>Adjusting Hold-Down – Short Knife Guards, page 659</i></li> </ul>
Reel too far back	Move the reel forward	<i>3.9.12 Reel Fore-Aft Position, page 252</i>
<b>Symptom: Knife plugging</b>		
Reel too high or too far forward	Lower the reel or move the reel rearward	<ul style="list-style-type: none"> <li>• <i>3.9.11 Reel Height, page 247</i></li> <li>• <i>3.9.12 Reel Fore-Aft Position, page 252</i></li> </ul>
Ground speed too high	Decrease the ground speed	<i>3.9.7 Ground Speed, page 242</i>

## TROUBLESHOOTING

**Table 6.2 Troubleshooting – Cutting Action and Knife Components (continued)**

Problem	Solution	Refer to
Improper knife hold-down adjustment	Adjust the hold-down	<ul style="list-style-type: none"> <li>• <i>Adjusting Hold-Down – Pointed Knife Guards, page 646</i></li> <li>• <i>Adjusting Hold-Down – Short Knife Guards, page 659</i></li> </ul>
Dull or broken knife section	Replace the corresponding knife section	<i>4.8.1 Replacing Knife Section, page 629</i>
Bent or broken guards	Align or replace the guards	<i>Adjusting Knife Guards and Guard Bar, page 641</i>
Reel fingers not lifting crop properly ahead of knife	Adjust the reel position/ finger pitch	<ul style="list-style-type: none"> <li>• <i>3.9.12 Reel Fore-Aft Position, page 252</i></li> <li>• <i>3.9.13 Reel Tine Pitch, page 261</i></li> </ul>
Steel pick-up fingers contacting knife	Increase the reel clearance from the cutterbar / adjust the frown	<i>4.13.1 Reel-to-Cutterbar Clearance, page 720</i>
Mud or dirt build-up on cutterbar	Raise the cutterbar by lowering skid shoes	<i>3.9.2 Cutting on Ground, page 207</i>
Mud or dirt build-up on cutterbar	Flatten the header angle	<i>3.9.5 Header Angle, page 232</i>
Knife is not operating at recommended speed	Check the engine speed of the combine or the header knife speed	<ul style="list-style-type: none"> <li>• Combine operator’s manual</li> <li>• <i>Checking Knife Speed, page 245</i></li> </ul>
<b>Symptom: Excessive header vibration</b>		
Excessive knife wear	Replace the knife	<ul style="list-style-type: none"> <li>• <i>4.8.2 Removing Knife, page 630</i></li> <li>• <i>4.8.3 Installing Knife, page 631</i></li> </ul>
Knife hold-down not adjusted properly	Adjust the hold-down	<ul style="list-style-type: none"> <li>• <i>Adjusting Hold-Down – Pointed Knife Guards, page 646</i></li> <li>• <i>Adjusting Center Hold-Down on Double-Knife Header – Pointed Knife Guards, page 651</i></li> <li>• <i>Adjusting Hold-Down – Short Knife Guards, page 659</i></li> <li>• <i>Adjusting Center Hold-Down – Short Knife Guards, page 663</i></li> </ul>
Loose or worn knifehead pin or drive arm	Tighten or replace the parts	<ul style="list-style-type: none"> <li>• <i>4.8.2 Removing Knife, page 630</i></li> <li>• <i>4.8.3 Installing Knife, page 631</i></li> </ul>
<b>Symptom: Excessive vibration of float module and header</b>		
Incorrect knife speed	Adjust the knife speed	<ul style="list-style-type: none"> <li>• <i>Checking Knife Speed, page 245</i></li> <li>• Dealer</li> </ul>
Bent cutterbar	Straighten the cutterbar	Dealer
<b>Symptom: Excessive breakage of knife sections or guards</b>		

## TROUBLESHOOTING

**Table 6.2 Troubleshooting – Cutting Action and Knife Components (continued)**

Problem	Solution	Refer to
Knife hold-down not adjusted properly	Adjust the hold-down	<ul style="list-style-type: none"> <li>• <i>Adjusting Hold-Down – Pointed Knife Guards, page 646</i></li> <li>• <i>Adjusting Hold-Down – Short Knife Guards, page 659</i></li> </ul>
Cutterbar operating too low in stony conditions	Raise the cutterbar with skid shoes	<i>3.9.2 Cutting on Ground, page 207</i>
Float is set too heavy	Adjust the float springs for a lighter float	<i>Checking and Adjusting Header Float, page 210</i>
Bent or broken guard	Straighten or replace the guard	<ul style="list-style-type: none"> <li>• <i>4.8.5 Pointed Knife Guards and Hold-Downs, page 634</i></li> <li>• <i>4.8.6 Short Knife Guards and Hold-Downs, page 652</i></li> </ul>
Header angle too steep	Flatten the header angle	<i>3.9.5 Header Angle, page 232</i>
<b>Symptom: Knife back breakage</b>		
Bent or broken guard	Straighten or replace the guard	<ul style="list-style-type: none"> <li>• <i>4.8.5 Pointed Knife Guards and Hold-Downs, page 634</i></li> <li>• <i>4.8.6 Short Knife Guards and Hold-Downs, page 652</i></li> </ul>
Worn knifehead pin	Replace the knifehead pin	<ul style="list-style-type: none"> <li>•</li> <li>•</li> </ul>
Dull knife	Replace the knife	<ul style="list-style-type: none"> <li>• <i>4.8.2 Removing Knife, page 630</i></li> <li>• <i>4.8.3 Installing Knife, page 631</i></li> </ul>
Knife speed too fast	Lower the knife speed	Dealer
Loose knife section hardware	Check and tighten all of the knife hardware	—

## 6.3 Reel Delivery

Use the following tables to determine the cause of reel delivery problems and the recommended repair procedure.

**Table 6.3 Troubleshooting – Reel Delivery**

Problem	Solution	Refer to
<b>Symptom: Reel not releasing material in normal standing crop</b>		
Reel speed too fast	Reduce the reel speed	<i>3.9.6 Reel Speed, page 240</i>
Reel too low	Raise the reel	<i>3.9.11 Reel Height, page 247</i>
Reel tines too aggressive	Reduce the cam setting	<i>3.9.13 Reel Tine Pitch, page 261</i>
Reel too far back	Move the reel forward	<i>3.9.12 Reel Fore-Aft Position, page 252</i>
<b>Symptom: Reel not releasing material in lodged and standing crop (reel fully lowered)</b>		
Reel tines too aggressive for standing crop	Reduce the cam setting by one or two or move reel forward	<i>3.9.13 Reel Tine Pitch, page 261</i>
<b>Symptom: Wrapping on the end of the reel</b>		
Reel tines too aggressive	Reduce the cam setting	<i>3.9.13 Reel Tine Pitch, page 261</i>
Reel too low	Raise the reel	<i>3.9.11 Reel Height, page 247</i>
Reel speed too fast	Reduce the reel speed	<i>3.9.6 Reel Speed, page 240</i>
Reel not centered in header	Center the reel in the header	<i>4.13.3 Centering Reel, page 727</i>
<b>Symptom: Reel releases crop too quickly</b>		
Reel tines not aggressive enough	Increase the cam setting to match reel delivery to the reel fore-aft position	<i>3.9.13 Reel Tine Pitch, page 261</i>
Reel too far forward	Move the reel back to match the reel cam setting	<i>3.9.12 Reel Fore-Aft Position, page 252</i>
<b>Symptom – Reel will not lift</b>		
Reel lift couplers are incompatible or defective	Change the quick coupler	Dealer
<b>Symptom – Reel will not turn</b>		
Quick couplers not properly connected	Connect the couplers	<i>3.6 Header Attachment/Detachment, page 74</i>
Reel drive chain disconnected or broken	Connect/replace the chain	<ul style="list-style-type: none"> <li>•</li> <li>• Dealer</li> </ul>
<b>Symptom: Reel motion uneven under no load</b>		
Excessive slack in reel drive chain	Tighten the chain	<i>Tightening Reel Drive Chain, page 750</i>
<b>Symptom: Reel motion is uneven or stalls in heavy crops</b>		
Reel speed too fast	Reduce the reel speed	<i>3.9.6 Reel Speed, page 240</i>
Reel fingers not aggressive enough	Move the reel finger or the cam setting to a more aggressive finger pitch notch	<i>3.9.13 Reel Tine Pitch, page 261</i>
Reel too low	Raise the reel	<i>3.9.11 Reel Height, page 247</i>
Relief valve on combine (not on combine float module) has low relief pressure setting	Increase the relief pressure to the manufacturer's recommendations	Combine operator's manual
Low oil reservoir level on combine	Fill to the proper level	Combine operator's manual
<b>NOTE:</b> There may be more than one reservoir		



## TROUBLESHOOTING

**Table 6.3 Troubleshooting – Reel Delivery (continued)**

Problem	Solution	Refer to
Relief valve malfunction	Replace the relief valve	Combine operator's manual
Cutting tough crops with standard torque (19-tooth) reel drive sprocket	Replace the sprocket with an appropriate high torque sprocket to match the combine reel circuit pressure	<ul style="list-style-type: none"> <li>• <a href="#">4.14.2 Reel Drive Sprocket, page 752</a></li> <li>• Install Two Speed Kit (MD #311882)</li> </ul>
<b>Symptom: Plastic fingers cut at tip</b>		
Insufficient reel to cutterbar clearance	Increase the clearance	<a href="#">4.13.1 Reel-to-Cutterbar Clearance, page 720</a>
<b>Symptom: Plastic fingers bent rearward at tip</b>		
Reel digging into ground with reel speed slower than ground speed	Raise the header	<ul style="list-style-type: none"> <li>• <a href="#">3.9.1 Cutting off Ground, page 189</a></li> <li>• <a href="#">3.9.2 Cutting on Ground, page 207</a></li> </ul>
Reel digging into ground with reel speed slower than ground speed	Decrease the header tilt	<a href="#">3.9.5 Header Angle, page 232</a>
Reel digging into ground with reel speed slower than ground speed	Move the reel aft	<a href="#">3.9.12 Reel Fore-Aft Position, page 252</a>
<b>Symptom: Plastic fingers bent forward at tip</b>		
Reel digging into the ground with reel speed faster than ground speed	Raise the header	<ul style="list-style-type: none"> <li>• <a href="#">3.9.1 Cutting off Ground, page 189</a></li> <li>• <a href="#">3.9.2 Cutting on Ground, page 207</a></li> </ul>
Reel digging into the ground with reel speed faster than ground speed	Decrease the header tilt	<a href="#">3.9.5 Header Angle, page 232</a>
Reel digging into ground with reel speed faster than ground speed	Move the reel aft	<a href="#">3.9.12 Reel Fore-Aft Position, page 252</a>
<b>Symptom: Plastic fingers bent close to tine tube</b>		
Excessive plugging at cutterbar with wads of crop accumulating at cutterbar while maintaining reel operation	Correct the plugging/cutting issues	<a href="#">3.10 Unplugging Cutterbar, page 543</a>
Excessive plugging at cutterbar with wads of crop accumulating at cutterbar while maintaining reel operation	Stop the reel before plugging becomes excessive	<a href="#">3.10 Unplugging Cutterbar, page 543</a>

## 6.4 Troubleshooting Header and Drapers

Use the following tables to determine the header and draper problems and the recommended repair procedure.

**Table 6.4 Troubleshooting – Header and Drapers**

Problem	Solution	Refer to
<b>Symptom: Insufficient header lift</b>		
Low relief pressure	Increase the relief pressure	Combine Dealer
<b>Symptom: Insufficient side draper speed</b>		
Speed control is set too low	Increase the speed control setting	<a href="#">3.9.8 Side Draper Speed, page 243</a>
Combine header drive is too slow	Adjust to the correct speed for the combine model	Combine operator's manual
<b>Symptom: Insufficient feed draper speed</b>		
Relief pressure is too low	Test the feed draper hydraulic system	Dealer
Combine header drive is too slow	Adjust to the correct speed for the combine model	Combine operator's manual
<b>Symptom: Feed draper will not move</b>		
Drapers are loose	Tighten the drapers	<a href="#">4.10.2 Checking and Adjusting Feed Draper Tension, page 674</a>
Drive or idler roller wrapped with material	Loosen the draper and clean the rollers	<a href="#">4.10.2 Checking and Adjusting Feed Draper Tension, page 674</a>
Slat or connector bar jammed by frame or material	Loosen the draper and clear the obstruction	<a href="#">4.10.2 Checking and Adjusting Feed Draper Tension, page 674</a>
Roller bearing seized	Replace the roller bearing	<a href="#">Replacing Feed Draper Idler Roller Bearing, page 688</a>
Low hydraulic oil	Fill the combine hydraulic oil reservoir to the full level	Combine operator's manual
Incorrect relief setting at flow control valve	Adjust the relief setting	Dealer
<b>Symptom: Side draper is stalling</b>		
Material not feeding evenly off knife	Lower the reel	<a href="#">3.9.11 Reel Height, page 247</a>
Material not feeding evenly off knife	Install short knife guards	<a href="#">4.8.6 Short Knife Guards and Hold-Downs, page 652</a>
<b>Symptom: Bulky crop does not flow evenly</b>		
Header angle is too low	Increase the header angle	<a href="#">3.9.5 Header Angle, page 232</a>
Material overload on drapers	Increase the side draper speed	<a href="#">3.9.8 Side Draper Speed, page 243</a>
Material overload on drapers	Install an upper cross auger	<a href="#">5.1.5 Full Length Upper Cross Auger, page 789</a>
Material overload on drapers	Add flighting extensions	Dealer
<b>Symptom: Drapers back-feed</b>		
Drapers running too slow in heavy crop	Increase the draper speed	<a href="#">3.9.8 Side Draper Speed, page 243</a>
<b>Symptom: Crop is thrown across the opening and under the opposite side draper</b>		
Drapers running too fast in light crop	Reduce the draper speed	<a href="#">3.9.8 Side Draper Speed, page 243</a>

## TROUBLESHOOTING

Table 6.4 Troubleshooting – Header and Drapers (continued)

Problem	Solution	Refer to
<b>Symptom: Material accumulates on the end deflectors and releases in bunches</b>		
End deflectors are too wide	For headers with manual deck shift, trim the deflector or replace with a narrow deflector (MD #172381)	<i>3.10 Unplugging Cutterbar, page 543</i>

## TROUBLESHOOTING

### 6.5 Cutting Edible Beans

Use the following tables to determine the cause of any cutting edible bean problems and the recommended solutions.

**Table 6.5 Troubleshooting – Cutting Edible Beans**

Problem	Solution	Refer to
<b>Symptom: Plants are being stripped and left complete or partial plants are being left behind</b>		
Header off the ground	Lower the header to the ground and run the header on skid shoes and/or the cutterbar	<i>3.9.2 Cutting on Ground, page 207</i>
Float set too light—header rides on high spots and does not lower soon enough	<ol style="list-style-type: none"> <li>1. Set the float to 335–338 N (75–85 lbf).</li> <li>2. Adjust the float as necessary to prevent the header from bouncing excessively or plowing into soft ground.</li> </ol>	<i>3.9.3 Header Float, page 209</i>
Reel too high with cylinders fully retracted	Adjust the reel height	<i>3.9.11 Reel Height, page 247</i>
Finger pitch not aggressive enough	Adjust the finger pitch	<i>3.9.13 Reel Tine Pitch, page 261</i>
Reel too far aft	With the header on the ground and the header angle properly adjusted, move the reel forward until the fingertips skim the soil surface	<i>3.9.12 Reel Fore-Aft Position, page 252</i>
Header angle too shallow	Adjust the header angle	<i>Adjusting Header Angle from Combine, page 234</i>
Header angle too shallow	Increase the header angle by fully retracting the lift cylinders (if cutting on ground)	<i>Adjusting Header Angle from Combine, page 234</i>
Reel too slow	Adjust the reel speed to be slightly faster than ground speed	<i>3.9.6 Reel Speed, page 240</i>
Ground speed too fast	Lower the ground speed	<i>3.9.7 Ground Speed, page 242</i>
Skid shoes too low	Raise the skid shoes to the highest setting	<i>3.9.2 Cutting on Ground, page 207</i>
Dirt packing on bottom of cutterbar with plastic wear strips on cutterbar; raises the cutterbar off the ground	<ul style="list-style-type: none"> <li>• Increase the float</li> <li>• The ground is too wet – allow the soil to dry</li> <li>• Manually clean the bottom of the cutterbar when excessive accumulation occurs</li> </ul>	<i>Checking and Adjusting Header Float, page 210</i>
Header not level	Level the header	Dealer
Worn or damaged knife sections	Replace the sections or replace the knife	<i>4.8 Knife, page 629</i>

## TROUBLESHOOTING

**Table 6.5 Troubleshooting – Cutting Edible Beans (continued)**

Problem	Solution	Refer to
Parts of vines get caught in pointed guard tips  <b>NOTE:</b> (This problem occurs more in row-cropped beans that are hilled from cultivating.)	Install the short knife guard conversion kit	<i>4.8.6 Short Knife Guards and Hold-Downs, page 652</i>
Pushing of crop debris on the ground	Install short knife guards	<i>4.8.6 Short Knife Guards and Hold-Downs, page 652</i>
Knife speed too low	Increase the feeder house speed or ensure that the knife speed is set within the recommended range	<ul style="list-style-type: none"> <li>• <i>3.9.10 Knife Speed Information, page 245</i></li> <li>• <i>Checking Knife Speed, page 245</i></li> </ul>
<b>Symptom: Excessive losses at dividers</b>		
Divider rod running down crop and shattering the pods	Remove the divider rod	<i>3.9.15 Crop Dividers, page 268</i>
Vines and plants build up on the endsheet	Install divider rods	<i>3.9.15 Crop Dividers, page 268</i>
<b>Symptom: Plant vines pinch between the top of the draper and the cutterbar</b>		
Shifting the decks with the header raised does not clean out the cutterbar debris	Manually remove the debris from the cutterbar cavity	—
<b>Symptom: Crop accumulates at the guards and does not move rearward onto the drapers</b>		
Reel finger pitch not aggressive enough	Increase the finger aggressiveness (cam position)	<i>3.9.13 Reel Tine Pitch, page 261</i>
Reel too high	Lower the reel	<i>3.9.11 Reel Height, page 247</i>
Minimum reel to cutterbar clearance setting too high	Adjust the minimum reel height with the cylinders fully retracted	<i>4.13.1 Reel-to-Cutterbar Clearance, page 720</i>
Reel too far forward	Reposition the reel	<i>3.9.12 Reel Fore-Aft Position, page 252</i>
<b>Symptom: Crop is wrapping around the reel</b>		
Reel too low	Raise the reel	<i>3.9.11 Reel Height, page 247</i>
<b>Symptom: The reel is shattering pods</b>		
Reel too far forward	Reposition the reel	<i>3.9.12 Reel Fore-Aft Position, page 252</i>
Reel speed too high	Reduce the reel speed	<i>3.9.6 Reel Speed, page 240</i>
Bean pods too dry	Cut the crop at night when dew is present and the pods have softened	—
Reel finger pitch not aggressive enough	Increase the finger aggressiveness (cam position)	<i>3.9.13 Reel Tine Pitch, page 261</i>
<b>Symptom: The cutterbar guards are breaking</b>		
Float insufficient (float setting too heavy)	Increase the float (adjust to lighter float setting)	<i>3.9.3 Header Float, page 209</i>

## TROUBLESHOOTING

**Table 6.5 Troubleshooting – Cutting Edible Beans (continued)**

Problem	Solution	Refer to
Excessive number of rocks in field	Consider installing optional short knife guards  <b>NOTE:</b> With the installation of short knife guards, you are trading guard damage for knife section damage (although changing sections with short knife guards is easier).	Dealer
<b>Symptom: The cutterbar is pushing too much debris and dirt</b>		
Header too heavy	Make the header lighter	<a href="#">3.9.3 Header Float, page 209</a>
Header angle too steep	Decrease the header angle	<a href="#">3.9.5 Header Angle, page 232</a>
Guards plug with debris and/or soil	Install short knife guards	<a href="#">4.8.6 Short Knife Guards and Hold-Downs, page 652</a>
Insufficient support for the header	Install center skid shoes	<a href="#">3.9.2 Cutting on Ground, page 207</a>
<b>Symptom: Crop is wrapping around the reel ends</b>		
Uncut crop interfering on reel ends	Add reel endshields	Header parts catalog
<b>Symptom: The reel occasionally carries over plants in the same location</b>		
Steel fingers bent and hooking plants from drapers	Straighten the fingers	—
Dirt accumulation on end of fingers preventing plants from falling off fingers onto drapers	Raise the reel	<a href="#">3.9.11 Reel Height, page 247</a>
Dirt accumulation on end of fingers preventing plants from falling off fingers onto drapers	Adjust the reel fore-aft position to move the fingers out of the ground	<a href="#">3.9.12 Reel Fore-Aft Position, page 252</a>
<b>Symptom: The cutterbar is pushing soil</b>		
Tire tracks or row crop ridges	Cut at an angle to crop rows or ridges	—
Rolling terrain along length of field	Cut at 90° to the rolling terrain (provided knife floats across without digging in)	—
<b>Symptom: The reel is carrying over an excessive amount of plants or wads</b>		
Excessive accumulation of crop on drapers (up to reel center tube)	Increase the draper speed	<a href="#">3.9.8 Side Draper Speed, page 243</a>
Finger pitch too slow	Increase the finger pitch	<a href="#">3.9.13 Reel Tine Pitch, page 261</a>

## 6.6 CLAAS Multicoupler Error Codes for Troubleshooting

The multicoupler in the CLAAS integration kit is equipped with a blink indicator, which displays error codes via a red LED. A list of error codes is provided. If no errors are detected, the blink indicator LED will be solid green.

An error code consists of a two-digit sequence, which can be determined by interpreting the sequence of blinks produced by the blink indicator on the CLAAS multicoupler. Each code consists of a specific combination of four types of outputs: digit delays, blink delays, long blinks, and short blinks.

Refer to the legend below to learn how to interpret error codes:

- Long blinks are indicated by \_\_\_\_
- Short blinks are indicated by \_
- The delay between the first and second digits is indicated by /
- The delay between blinks in a single digit code indicated by -

Refer to Table 6.6, [page 822](#) for an explanation of what each blink code means.

The blink indicator will continue to display error codes until the underlying problem is resolved. If there are multiple error codes, they will be displayed in sequence, with a long delay occurring between codes.

Once the underlying problem has been corrected, the combine will need to be turned off and on to reset the blink indicator.

## TROUBLESHOOTING

**Table 6.6 Error Codes Indicated by Blink Sequence – CLAAS Integration Kit Multicoupler Blink Indicator**

Code #	Indicated Fault	Blink Sequence
1	Side draper valve: open circuit	___ / _
2	Side draper valve: over current	___ / -_-
3	Side draper speed: open circuit	___ / -_-_-
4	Side draper speed: over current	___ / -_-_-_-
5	Selector1 valve: open circuit	___ / -_-_-_-_-
6	Selector1 valve: over current	___ / -_-_-_-_-_-
7	Selector2 valve: open circuit	___ / -_-_-_-_-_-_-
8	Selector2 valve: over current	___ / -_-_-_-_-_-_-_-
9	Reel fore valve: open circuit	___ / -_-_-_-_-_-_-_-
10	Reel fore valve: over current	_ / ___
11	Reel aft valve: open circuit	_ / _
12	Reel aft valve: over current	_ / -_-
13	Side draper speed input signal: out of range	_ / -_-_-
14	Side draper speed input signal: open	_ / -_-_-_-
19	Controller: over temperature	_ / -_-_-_-_-_-_-_-
20	Reel fore input: open or shorting to ground	-_- / ___
21	Reel fore input: shorting to power	-_- / _
22	Reel aft input: open or shorting to ground	-_- / -_-
23	Reel aft input: shorting to power	-_- / -_-_-
24	Tilt fore input: open or shorting to ground	-_- / -_-_-_-
25	Tilt fore input: shorting to power	-_- / -_-_-_-_-
26	Tilt aft input: open or shorting to ground	-_- / -_-_-_-_-_-
27	Tilt aft input: shorting to power	-_- / -_-_-_-_-_-_-
28	CAN error	-_- / -_-_-_-_-_-_-_-
29	Left height sensor: voltage high	-_- / -_-_-_-_-_-_-_-
30	Left height sensor: voltage low	-_- / ___
31	Controller: below temperature	-_- / _
35	Right height sensor: voltage high	-_- / -_-_-_-_-
36	Right height sensor: voltage low	-_- / -_-_-_-_-
37	Reel fore-aft sensor: voltage high	-_- / -_-_-_-_-_-
38	Reel fore-aft sensor: voltage low	-_- / -_-_-_-_-_-_-
39	Controller: electronic voltage low	-_- / -_-_-_-_-_-_-_-
40	Controller: electronic voltage high	-_- / ___
41	Controller: output supply over voltage	-_- / _
42	Controller: output supply under voltage	-_- / -_-
43	Reel fore-aft sensor: not calibrated	-_- / -_-_-



# Chapter 7: Reference

Refer to the procedures and information in this chapter as needed.

## 7.1 Torque Specifications

The following tables provide torque values for various bolts, cap screws, and hydraulic fittings. Refer to these values only when no other torque value has been specified in a given procedure.

- Tighten all bolts to the torque values specified in the charts below, unless you are directed otherwise in this manual.
- Replace removed hardware with hardware of the same strength and grade.
- Refer to the torque value tables as a guide when periodically checking the tightness of bolts.
- Understand the torque categories for bolts and cap screws by reading the markings on their heads.

### Jam nuts

Jam nuts require less torque than nuts used for other purposes. When applying torque to finished jam nuts, multiply the torque applied to regular nuts by 0.65 to obtain the modified torque value.

### Self-tapping screws

Refer to the standard torque values when installing the self-tapping screws. Do **NOT** install the self-tapping screws on structural or otherwise critical joints.

### 7.1.1 Metric Bolt Specifications

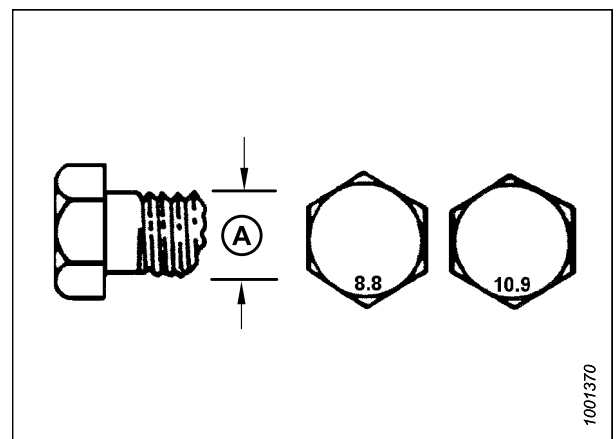
Specifications are provided for the appropriate final torque values to secure various sizes of metric bolts.

#### NOTE:

The torque values provided in the following metric bolt torque tables apply to hardware installed dry; that is, hardware with no grease, oil, or threadlocker on the threads or heads. Do **NOT** add grease, oil, or threadlocker to bolts or cap screws unless you are directed to do so in this manual.

**Table 7.1 Metric Class 8.8 Bolts and Class 9 Free Spinning Nut**

Nominal Size (A)	Torque (Nm)		Torque (lbf-ft) (*lbf-in)	
	Min.	Max.	Min.	Max.
3-0.5	1.4	1.6	*13	*14
3.5-0.6	2.2	2.5	*20	*22
4-0.7	3.3	3.7	*29	*32
5-0.8	6.7	7.4	*59	*66
6-1.0	11.4	12.6	*101	*112
8-1.25	28	30	20	23
10-1.5	55	60	40	45
12-1.75	95	105	70	78
14-2.0	152	168	113	124
16-2.0	236	261	175	193
20-2.5	460	509	341	377
24-3.0	796	879	589	651



**Figure 7.1: Bolt Grades**

REFERENCE

Table 7.2 Metric Class 8.8 Bolts and Class 9 Distorted Thread Nut

Nominal Size (A)	Torque (Nm)		Torque (lbf-ft) (*lbf-in)	
	Min.	Max.	Min.	Max.
3-0.5	1	1.1	*9	*10
3.5-0.6	1.5	1.7	*14	*15
4-0.7	2.3	2.5	*20	*22
5-0.8	4.5	5	*40	*45
6-1.0	7.7	8.6	*69	*76
8-1.25	18.8	20.8	*167	*185
10-1.5	37	41	28	30
12-1.75	65	72	48	53
14-2.0	104	115	77	85
16-2.0	161	178	119	132
20-2.5	314	347	233	257
24-3.0	543	600	402	444

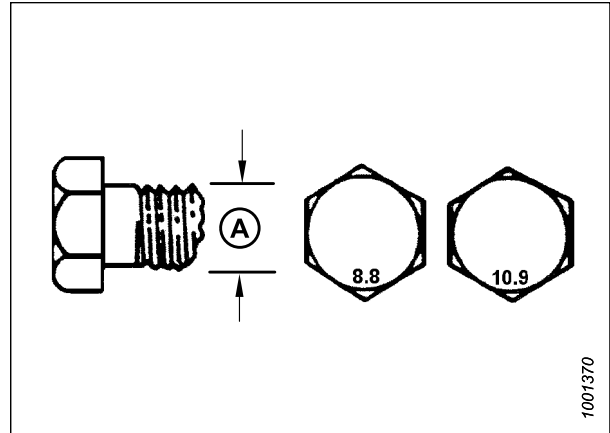


Figure 7.2: Bolt Grades

Table 7.3 Metric Class 10.9 Bolts and Class 10 Free Spinning Nut

Nominal Size (A)	Torque (Nm)		Torque (lbf-ft) (*lbf-in)	
	Min.	Max.	Min.	Max.
3-0.5	1.8	2	*18	*19
3.5-0.6	2.8	3.1	*27	*30
4-0.7	4.2	4.6	*41	*45
5-0.8	8.4	9.3	*82	*91
6-1.0	14.3	15.8	*140	*154
8-1.25	38	42	28	31
10-1.5	75	83	56	62
12-1.75	132	145	97	108
14-2.0	210	232	156	172
16-2.0	326	360	242	267
20-2.5	637	704	472	521
24-3.0	1101	1217	815	901

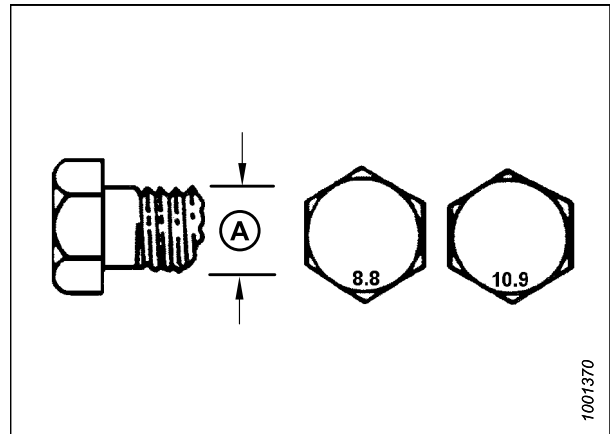


Figure 7.3: Bolt Grades

REFERENCE

Table 7.4 Metric Class 10.9 Bolts and Class 10 Distorted Thread Nut

Nominal Size (A)	Torque (Nm)		Torque (lbf-ft) (*lbf-in)	
	Min.	Max.	Min.	Max.
3-0.5	1.3	1.5	*12	*13
3.5-0.6	2.1	2.3	*19	*21
4-0.7	3.1	3.4	*28	*31
5-0.8	6.3	7	*56	*62
6-1.0	10.7	11.8	*95	*105
8-1.25	26	29	19	21
10-1.5	51	57	38	42
12-1.75	90	99	66	73
14-2.0	143	158	106	117
16-2.0	222	246	165	182
20-2.5	434	480	322	356
24-3.0	750	829	556	614

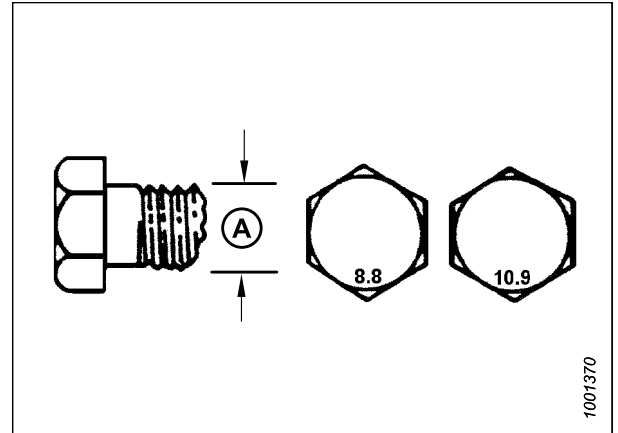


Figure 7.4: Bolt Grades

### 7.1.2 Metric Bolt Specifications – Cast Aluminum

Specifications are provided for the appropriate final torque values for various sizes of metric bolts in cast aluminum.

**NOTE:**

The torque values provided in the following metric bolt torque tables apply to hardware installed dry; that is, hardware with no grease, oil, or threadlocker on the threads or heads. Do **NOT** add grease, oil, or threadlocker to bolts or cap screws unless you are directed to do so in this manual.

Table 7.5 Metric Bolt Bolting into Cast Aluminum

Nominal Size (A)	Bolt Torque			
	8.8 (Cast Aluminum)		10.9 (Cast Aluminum)	
	Nm	lbf-ft	Nm	lbf-ft
M3	–	–	–	1
M4	–	–	4	2.6
M5	–	–	8	5.5
M6	9	6	12	9
M8	20	14	28	20
M10	40	28	55	40
M12	70	52	100	73
M14	–	–	–	–
M16	–	–	–	–

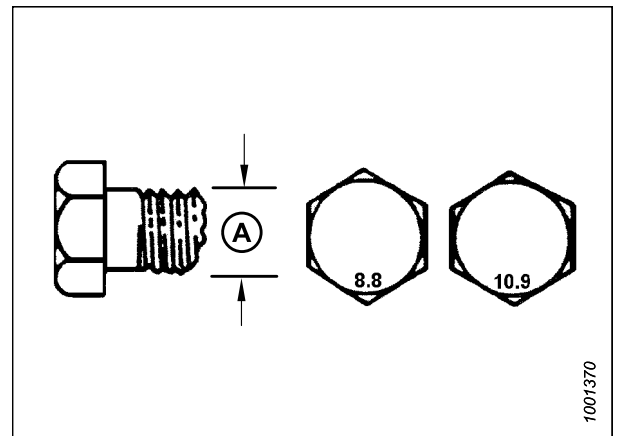


Figure 7.5: Bolt Grades

### 7.1.3 O-Ring Boss Hydraulic Fittings – Adjustable

The standard torque values are provided for adjustable hydraulic fittings. If a procedure specifies a different torque value for the same type and size of fitting found in this topic, refer to the value specified in the procedure instead.

1. Inspect O-ring (A) and seat (B) for dirt or defects.
2. Back off lock nut (C) as far as possible. Ensure that washer (D) is loose and that it is pushed toward lock nut (C) as far as possible.
3. Ensure that O-ring (A) is **NOT** on the threads. Adjust O-ring (A) if necessary.
4. Apply hydraulic system oil to O-ring (A).

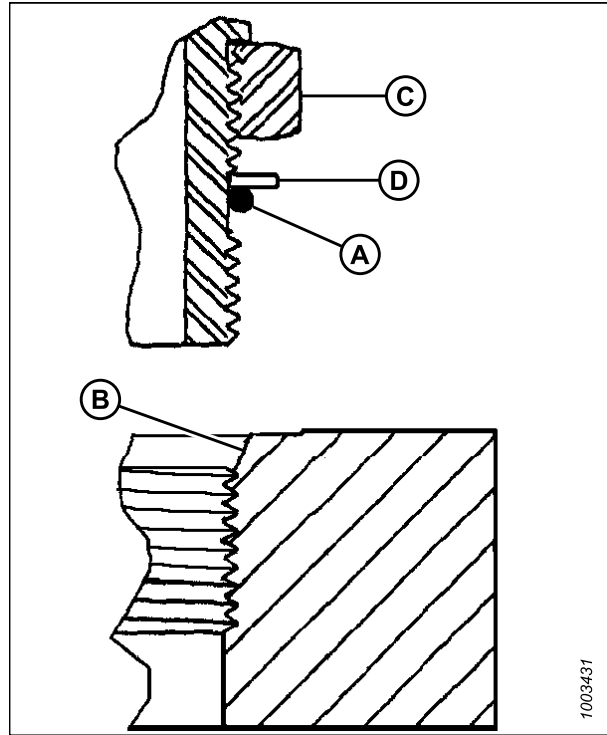


Figure 7.6: Hydraulic Fitting

5. Install fitting (B) into the port until backup washer (D) and O-ring (A) contact part face (E).
6. Position the angle fittings by unscrewing no more than one turn.
7. Turn lock nut (C) down to washer (D) and tighten it to the torque value indicated in the table. Use two wrenches, one on fitting (B) and the other on lock nut (C).
8. Verify the final condition of the fitting.

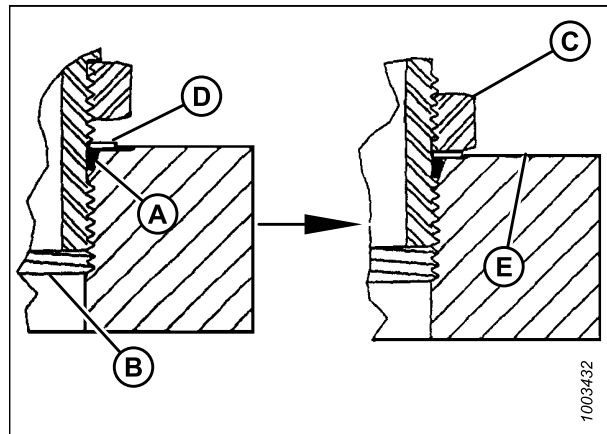


Figure 7.7: Hydraulic Fitting

REFERENCE

Table 7.6 O-Ring Boss (ORB) Hydraulic Fittings – Adjustable and Non-Adjustable

SAE Dash Size	Thread Size (in.)	Torque Value <sup>99</sup>	
		Nm	lbf-ft (*lbf-in)
-2	5/16-24	10-11	*89-97
-3	3/8-24	18-20	*159-177
-4	7/16-20	29-32	21-24
-5	1/2-20	32-35	24-26
-6	9/16-18	40-44	30-32
-8	3/4-16	70-77	52-57
-10	7/8-14	115-127	85-94
-12	1 1/16-12	183-201	135-148
-14	1 3/16-12	237-261	175-193
-16	1 5/16-12	271-298	200-220
-20	1 5/8-12	339-373	250-275
-24	1 7/8-12	414-455	305-336
-32	2 1/2-12	509-560	375-413

7.1.4 O-Ring Boss Hydraulic Fittings – Non-Adjustable

The standard torque values for non-adjustable hydraulic fittings are provided. If a procedure specifies a different torque value for the same type and size of fitting found in this topic, use the value specified in the procedure instead.

1. Inspect O-ring (A) and seat (B) for dirt or defects.
2. Ensure that O-ring (A) is **NOT** on the threads. Adjust O-ring (A) if necessary.
3. Apply hydraulic system oil to the O-ring.
4. Install fitting (C) into the port until the fitting is hand-tight.
5. Torque fitting (C) according to values in Table 7.7, page 827.
6. Verify the final condition of the fitting.

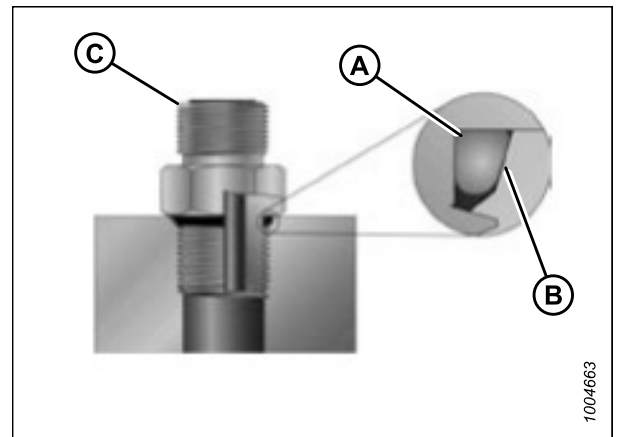


Figure 7.8: Hydraulic Fitting

Table 7.7 O-Ring Boss (ORB) Hydraulic Fittings – Adjustable and Non-Adjustable

SAE Dash Size	Thread Size (in.)	Torque Value <sup>99</sup>	
		Nm	lbf-ft (*lbf-in)
-2	5/16-24	10-11	*89-97
-3	3/8-24	18-20	*159-177
-4	7/16-20	29-32	21-24
-5	1/2-20	32-35	24-26

99. Torque values shown are based on lubricated connections as in reassembly.

REFERENCE

Table 7.7 O-Ring Boss (ORB) Hydraulic Fittings – Adjustable and Non-Adjustable (continued)

SAE Dash Size	Thread Size (in.)	Torque Value <sup>100</sup>	
		Nm	lbf-ft (*lbf-in)
-6	9/16-18	40-44	30-32
-8	3/4-16	70-77	52-57
-10	7/8-14	115-127	85-94
-12	1 1/16-12	183-201	135-148
-14	1 3/16-12	237-261	175-193
-16	1 5/16-12	271-298	200-220
-20	1 5/8-12	339-373	250-275
-24	1 7/8-12	414-455	305-336
-32	2 1/2-12	509-560	375-413

### 7.1.5 O-Ring Face Seal Hydraulic Fittings

The standard torque values are provided for O-ring face seal hydraulic fittings. If a procedure specifies a different torque value for the same type and size of fitting found in this topic, refer to the value specified in the procedure instead.

Torque values are shown in the Table 7.8, page 829.

1. Ensure that the sealing surfaces and the fitting threads are free of burrs, nicks, scratches, and any foreign material.



Figure 7.9: Hydraulic Fitting

100. Torque values shown are based on lubricated connections as in reassembly.

## REFERENCE

2. Apply hydraulic system oil to O-ring (B).
3. Align the tube or hose assembly so that the flat face of sleeve (A) or (C) comes into full contact with O-ring (B).
4. Thread tube or hose nut (D) until it is hand-tight. The nut should turn freely until it bottoms out.
5. Torque the fittings according to values in Table 7.8, page 829.

### NOTE:

If applicable, hold the hex flange on fitting body (E) to prevent the rotation of the fitting body and the hose when tightening fitting nut (D).

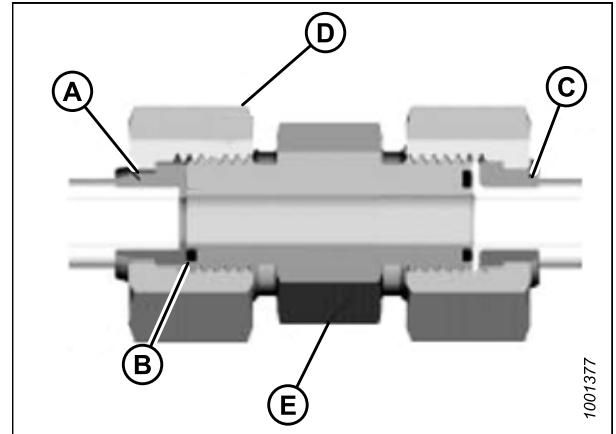


Figure 7.10: Hydraulic Fitting

6. Use three wrenches when assembling unions or joining two hoses together.
7. Verify the final condition of the fitting.

Table 7.8 O-Ring Face Seal (ORFS) Hydraulic Fittings

SAE Dash Size	Thread Size (in.)	Tube O.D. (in.)	Torque Value <sup>101</sup>	
			Nm	lbf-ft
-3	Note <sup>102</sup>	3/16	–	–
-4	9/16	1/4	25–28	18–21
-5	Note <sup>102</sup>	5/16	–	–
-6	11/16	3/8	40–44	30–32
-8	13/16	1/2	55–61	41–45
-10	1	5/8	80–88	59–65
-12	1 3/16	3/4	115–127	85–94
-14	Note <sup>102</sup>	7/8	–	–
-16	1 7/16	1	150–165	111–122
-20	1 11/16	1 1/4	205–226	151–167
-24	2	1 1/2	315–347	232–256
-32	2 1/2	2	510–561	376–414

### 7.1.6 Tapered Pipe Thread Fittings

The standard torque values are provided for tapered pipe thread fittings. If a procedure specifies a different torque value for the same type and size of fitting found in this topic, refer to the value specified in the procedure instead.

Assemble pipe fittings as follows:

1. Ensure that the fitting and the port threads are free of burrs, nicks, scratches, and any other form of contamination.
2. Apply paste-type pipe thread sealant to the external pipe threads.
3. Thread the fitting into the port until it is hand-tight.

101. Torque values and angles shown are based on lubricated connection as in reassembly.

102. O-ring face seal type end not defined for this tube size.

## REFERENCE

4. Torque the connector to the appropriate torque angle. The turns from finger tight (TFFT) and flats from finger tight (FFFT) values are shown in Table 7.9, page 830. Ensure that the tube end of a shaped connector (typically a 45° or 90° elbow) is aligned to receive the incoming tube or hose assembly. Always finish the alignment of the fitting in the direction of tightening. Never loosen the threaded connectors to achieve alignment.
5. Clean all residue and any excess thread conditioner with an appropriate cleaner.
6. Inspect the final condition of the fitting. Pay special attention to the possibility of cracks in the port opening.
7. Mark the final position of the fitting. If a fitting leaks, disassemble the fitting and check it for damage.

**NOTE:**

The failure of fittings due to over-torquing may not be evident until the fittings are disassembled and inspected.

**Table 7.9 Hydraulic Fitting Pipe Thread**

Tapered Pipe Thread Size	Recommended TFFT	Recommended FFFT
1/8-27	2-3	12-18
1/4-18	2-3	12-18
3/8-18	2-3	12-18
1/2-14	2-3	12-18
3/4-14	1.5-2.5	12-18
1-11 1/2	1.5-2.5	9-15
1 1/4-11 1/2	1.5-2.5	9-15
1 1/2-11 1/2	1.5-2.5	9-15
2-11 1/2	1.5-2.5	9-15



## 7.2 Conversion Chart

This manual uses both SI units (including metric) and US customary units (sometimes referred to as standard units) of measurement. A list of those units along with their abbreviations and conversion factors is provided here for your reference.

**Table 7.10 Conversion Chart**

Quantity	SI Units (Metric)		Factor	US Customary Units (Standard)	
	Unit Name	Abbreviation		Unit Name	Abbreviation
Area	hectare	ha	x 2.4710 =	acre	acres
Flow	liters per minute	L/min	x 0.2642 =	US gallons per minute	gpm
Force	Newton	N	x 0.2248 =	pound force	lbf
Length	millimeter	mm	x 0.0394 =	inch	in.
Length	meter	m	x 3.2808 =	foot	ft.
Power	kilowatt	kW	x 1.341 =	horsepower	hp
Pressure	kilopascal	kPa	x 0.145 =	pounds per square inch	psi
Pressure	megapascal	MPa	x 145.038 =	pounds per square inch	psi
Pressure	bar (Non-SI)	bar	x 14.5038 =	pounds per square inch	psi
Torque	Newton meter	Nm	x 0.7376 =	pound feet or foot pounds	lbf·ft
Torque	Newton meter	Nm	x 8.8507 =	pound inches or inch pounds	lbf·in
Temperature	degrees Celsius	°C	(°C x 1.8) + 32 =	degrees Fahrenheit	°F
Velocity	meters per minute	m/min	x 3.2808 =	feet per minute	ft/min
Velocity	meters per second	m/s	x 3.2808 =	feet per second	ft/s
Velocity	kilometers per hour	km/h	x 0.6214 =	miles per hour	mph
Volume	liter	L	x 0.2642 =	US gallon	US gal
Volume	milliliter	mL	x 0.0338 =	ounce	oz.
Volume	cubic centimeter	cm <sup>3</sup> or cc	x 0.061 =	cubic inch	in. <sup>3</sup>
Weight	kilogram	kg	x 2.2046 =	pound	lb.



# Index

## A

### AGCO combines

#### Challenger®

- attaching header to combine ..... 83
- detaching combine from header..... 87

#### Gleaner®

- attaching header to combine ..... 83
- detaching combine from header..... 87

#### IDEAL™ Series

- attaching header to combine ..... 105
- detaching combine from header..... 109

#### Massey Ferguson®

- attaching header to combine ..... 83
- detaching combine from header..... 87

### AHHC, *See* auto header height control

### augers ..... 612

#### auger drive sprockets

- adjusting auger drive chain tension..... 618

#### auger position ..... 185

#### auger to pan clearance..... 612

#### drive chains

- adjusting chain tension ..... 618
- checking chain tension..... 616
- checking tension..... 614
- lubricating ..... 587

#### feed auger configurations ..... 158

- medium configuration ..... 167
- narrow configuration..... 164
- ultra narrow configuration ..... 160
- ultra wide configuration..... 172
- wide configuration ..... 169

#### fingers..... 621

- adjusting finger timing ..... 626
- checking finger timing ..... 625
- installing ..... 184, 623
- removing..... 181, 621

#### flighting..... 174, 620

- installing ..... 176, 179
- optional feed auger flighting..... 797
- removing..... 174

#### tension springs

- checking and adjusting..... 187

#### tines, *See* fingers

### auto header height control

#### auto header height control

##### quick reference

- CLAAS Lexion 7000 series combine ..... 370
- CLAAS Lexion 8000 series combine ..... 370
- CLAAS Trion 600 series combine..... 370
- CLAAS Trion 700 series combine..... 370

#### Case IH 120 series combines ..... 312

##### adjusting

- preset cutting height..... 328

##### calibrating

- auto header height control..... 315

##### sensor output voltage

- checking voltage range from the cab..... 312

#### Case IH 130 series combines ..... 301, 303

#### Case IH 140 series combines ..... 301

#### Case IH 230 series combines ..... 312

##### adjusting

- preset cutting height..... 328

##### calibrating

- auto header height control..... 315

##### sensor output voltage

- checking voltage range from the cab..... 312

#### Case IH 240 series combines ..... 312

##### adjusting

- preset cutting height..... 328

##### calibrating

- auto header height control..... 315

##### sensor output voltage

- checking voltage range from the cab..... 312

#### Case IH 250 series combines ..... 312

##### adjusting

- preset cutting height..... 328

##### calibrating

- auto header height control..... 315

##### sensor output voltage

- checking voltage range from the cab..... 312

#### Case IH 5130/6130/7130 combines

##### adjusting

- preset cutting height..... 309

##### calibrating

- auto header height control..... 306

##### sensor output voltage

- checking voltage range from the cab..... 301

##### setting up header on combine display ..... 304

#### Case IH 5140/6140/7140 combines

##### adjusting

- preset cutting height..... 309

##### sensor output voltage

- checking voltage range from the cab..... 301

##### setting up header on combine display ..... 304

#### Case IH 7010 combines

##### sensor output voltage

- checking voltage range from the cab..... 312

#### Case IH combines

##### checking reel height sensor voltage..... 326

##### reel reverse ..... 329

##### reel speed sensor..... 333

##### side draper speed control..... 332

#### Case IH combines with version 28.00 software

##### calibrating auto header height control..... 320

## INDEX

<ul style="list-style-type: none"> <li>Challenger® 6 series combines ..... 335 <ul style="list-style-type: none"> <li>adjusting <ul style="list-style-type: none"> <li>header height ..... 341</li> <li>raise/lower rate ..... 342</li> <li>sensitivity..... 343</li> </ul> </li> <li>calibrating <ul style="list-style-type: none"> <li>auto header height control..... 338</li> </ul> </li> <li>engaging auto header height control..... 337</li> <li>sensor output voltage <ul style="list-style-type: none"> <li>checking from cab ..... 335</li> </ul> </li> </ul> </li> <li>Challenger® 7 series combines ..... 335 <ul style="list-style-type: none"> <li>sensor output voltage <ul style="list-style-type: none"> <li>checking from cab ..... 335</li> </ul> </li> </ul> </li> <li>CLAAS 600 Lexion series combines <ul style="list-style-type: none"> <li>calibrating <ul style="list-style-type: none"> <li>auto header height control..... 357</li> </ul> </li> </ul> </li> <li>CLAAS Lexion 600 series combines ..... 357 <ul style="list-style-type: none"> <li>adjusting <ul style="list-style-type: none"> <li>auto reel speed ..... 362</li> <li>cutting height ..... 360</li> <li>reel height ..... 368</li> <li>sensitivity..... 361</li> </ul> </li> <li>calibrating <ul style="list-style-type: none"> <li>reel fore-aft..... 364</li> <li>reel height ..... 364</li> </ul> </li> </ul> </li> <li>CLAAS Lexion 6000 series combines ..... 370 <ul style="list-style-type: none"> <li>adjusting auto reel speed ..... 378</li> <li>calibrating ..... 372</li> <li>setting cut and reel height..... 375</li> <li>setting the sensitivity ..... 376</li> <li>setup ..... 370</li> </ul> </li> <li>CLAAS Lexion 700 series combines ..... 357 <ul style="list-style-type: none"> <li>adjusting <ul style="list-style-type: none"> <li>auto reel speed ..... 362</li> <li>cutting height ..... 360</li> <li>reel height ..... 368</li> <li>sensitivity..... 361</li> </ul> </li> <li>calibrating <ul style="list-style-type: none"> <li>auto header height control..... 357</li> <li>reel fore-aft..... 364</li> <li>reel height ..... 364</li> </ul> </li> </ul> </li> <li>CLAAS Lexion 7000 combines ..... 370</li> <li>CLAAS Lexion 7000 series combines <ul style="list-style-type: none"> <li>adjusting auto reel speed ..... 378</li> <li>calibrating ..... 372</li> <li>setting cut and reel height..... 375</li> <li>setting the sensitivity ..... 376</li> <li>setup ..... 370</li> </ul> </li> <li>CLAAS Lexion 8000 series combines ..... 370 <ul style="list-style-type: none"> <li>adjusting auto reel speed ..... 378</li> <li>calibrating ..... 372</li> <li>setting cut and reel height..... 375</li> <li>setting the sensitivity ..... 376</li> <li>setup ..... 370</li> </ul> </li> <li>CLAAS Trion 600 series combines </li> </ul>	<ul style="list-style-type: none"> <li>adjusting auto reel speed ..... 378</li> <li>calibrating ..... 372</li> <li>setting cut and reel height..... 375</li> <li>setting the sensitivity ..... 376</li> <li>setup ..... 370</li> <li>CLAAS Trion 600 series combines ..... 370</li> <li>CLAAS Trion 700 series combines <ul style="list-style-type: none"> <li>adjusting auto reel speed ..... 378</li> <li>calibrating ..... 372</li> <li>setting cut and reel height..... 375</li> <li>setting the sensitivity ..... 376</li> <li>setup ..... 370</li> </ul> </li> <li>CLAAS Trion 700 series combines ..... 370</li> <li>CLAAS/CAT Lexion 500 series and model 600 combines ..... 345 <ul style="list-style-type: none"> <li>adjusting <ul style="list-style-type: none"> <li>auto reel speed ..... 353</li> <li>cutting height manually ..... 349</li> <li>preset cutting height ..... 348</li> <li>sensitivity..... 350</li> </ul> </li> <li>calibrating <ul style="list-style-type: none"> <li>auto header height control..... 345</li> <li>cutting height..... 348</li> </ul> </li> </ul> </li> <li>Gleaner® R65/R66/R75/R76 series combines <ul style="list-style-type: none"> <li>sensor output voltage <ul style="list-style-type: none"> <li>checking voltage range from the cab..... 383</li> </ul> </li> </ul> </li> <li>Gleaner® R65/R75 series combines ..... 383 <ul style="list-style-type: none"> <li>adjusting ground pressure ..... 391</li> <li>adjusting raise/lower rate ..... 391</li> <li>adjusting sensitivity..... 392</li> <li>calibrating auto header height control..... 386</li> <li>engaging auto header height control..... 385</li> <li>troubleshooting alarms and faults..... 393</li> <li>turning the accumulator off..... 390</li> </ul> </li> <li>Gleaner® S series combines ..... 383</li> <li>Gleaner® S series combines (pre-2016) <ul style="list-style-type: none"> <li>adjusting ground pressure ..... 391</li> <li>adjusting raise/lower rate ..... 391</li> <li>adjusting sensitivity..... 392</li> <li>calibrating auto header height control..... 386</li> <li>engaging auto header height control..... 385</li> <li>sensor output voltage <ul style="list-style-type: none"> <li>checking voltage range from the cab..... 383</li> </ul> </li> <li>troubleshooting alarms and faults..... 393</li> <li>turning the accumulator off..... 390</li> </ul> </li> <li>Gleaner® S9 series combines ..... 396 <ul style="list-style-type: none"> <li>calibrating <ul style="list-style-type: none"> <li>auto header height control..... 405</li> </ul> </li> <li>calibrating reel ..... 401</li> <li>operating ..... 410</li> <li>reviewing header in-field settings ..... 412</li> <li>setting automatic header controls ..... 403</li> <li>setting minimum reel speed ..... 401</li> <li>setting up the header ..... 396</li> </ul> </li> <li>IDEAL™ series combines..... 415</li> </ul>
--	--

## INDEX

calibrating reel .....	420
calibrating the header .....	423
operating .....	427
reviewing header in-field settings .....	429
setting automatic header controls .....	422
setting minimum reel speed .....	420
setting up the header .....	415
John Deere 60 series combines.....	431
adjusting	
drop rate valve threshold.....	438
sensing grain header height.....	437
sensitivity.....	437
calibrating	
auto header height control.....	433
sensor output voltage	
checking voltage range from the cab.....	431
turning the accumulator off.....	436
John Deere 70 series combines.....	440
adjusting	
raise/lower manual rate .....	443
sensitivity.....	447
calibrating	
AHHC .....	444
feeder house speed .....	443
sensor output voltage	
checking voltage range from the cab.....	440
John Deere S series combines.....	448
adjusting	
preset cutting height.....	457
sensitivity.....	456
adjusting raise/lower rate manually .....	451
calibrating	
reel height and reel fore-aft .....	466
calibrating auto header height control.....	452
calibrating feeder house fore-aft tilt.....	460
checking reel height sensor voltage.....	463
sensor output voltage	
checking voltage range from the cab.....	448
John Deere S7 series combines.....	469
calibrating	
feeder house .....	475
header.....	478
sensor output voltage	
checking voltage range from cab .....	472
setting up header .....	469
John Deere T series combines .....	448
adjusting	
preset cutting height.....	457
sensitivity.....	456
adjusting raise/lower rate manually .....	451
calibrating	
reel height and reel fore-aft .....	466
calibrating auto header height control.....	452
calibrating feeder house fore-aft tilt.....	460
checking reel height sensor voltage.....	463
sensor output voltage	
checking voltage range from the cab.....	448
John Deere X9 series combines.....	483
calibrating .....	485
cutting above ground level .....	493
cutting on ground .....	495
header controller	
checking error codes.....	497
reel reverse .....	499
using .....	491
Massey Ferguson® 6 series combines .....	335
adjusting	
header height .....	341
raise/lower rate .....	342
sensitivity.....	343
calibrating	
auto header height control.....	338
engaging auto header height control.....	337
sensor output voltage	
checking from cab .....	335
Massey Ferguson® 7 series combines .....	335
sensor output voltage	
checking from cab .....	335
New Holland 2015 CR series combines.....	513
calibrating auto header height control.....	520
calibrating reel fore-aft sensor .....	524
calibrating reel height sensor .....	524
engaging auto header height control.....	516
sensor output voltage	
checking voltage range from the cab.....	513
setting preset cutting height .....	528
setting up reel speed.....	519
New Holland CH series combines .....	513
calibrating auto header height control.....	520
calibrating reel fore-aft sensor .....	524
engaging auto header height control.....	516
reel reverse .....	533
sensor output voltage	
checking voltage range from the cab.....	513
setting maximum work height.....	530
setting preset cutting height .....	528
setting up reel speed.....	519
New Holland combines	
10 V adapter .....	300
checking reel height sensor voltage.....	527
New Holland CR series combines	
reel reverse .....	533
setting maximum work height.....	530
New Holland CR/CX series and CH combines	
configuring	
header tilt .....	531
header type.....	531
reel fore-aft.....	531
New Holland CR/CX series combines.....	500
adjusting	



## INDEX

- crop lifter kits ..... 787
    - storage kits ..... 787
  - cutterbar systems
    - adjusting
      - knife guards and guard bar ..... 641
      - pointed center hold-downs ..... 651
      - pointed knife guard hold-downs ..... 646
      - short knife guard center hold-downs ..... 663
      - short knife guard hold-downs ..... 659
    - adjusting four-point knife guard hold-downs ..... 646
    - installing knife ..... 631
    - options ..... 794
    - pointed knife guard configuration
      - single-knife headers ..... 635
    - pointed knife guards
      - checking center hold-downs ..... 650
      - checking hold-downs ..... 645
    - pointed knife guards and hold-downs ..... 634
    - removing knife ..... 630
    - replacing
      - center knife guards on double-knife headers ..... 660
      - pointed center knife guards on double-knife headers ..... 647
      - pointed knife guards ..... 643
      - short/end knife guards ..... 656
    - replacing damaged/broken knife section ..... 629
    - short knife guard configuration
      - single-knife headers ..... 653
    - short knife guards
      - checking center hold-downs ..... 662
      - checking hold-downs ..... 658
    - short knife guards and hold-downs ..... 652
    - unplugging ..... 543
  - cutting
    - off the ground ..... 189
      - adjusting stabilizer wheels ..... 190
      - adjusting transport wheels ..... 191
    - on ground level ..... 207
- D**
- daily start-up checks ..... 57
  - definitions ..... 27
  - divider rods ..... 287
    - installing ..... 288
    - removing ..... 288
  - draper roller bearings
    - inspecting ..... 707
  - drapers
    - adjusting side draper tracking ..... 706
  - float modules
    - adjusting, checking draper tension ..... 674
    - feed deck ..... 669
    - replacing feed draper ..... 669
  - side draper speed ..... 243
    - adjusting speed ..... 243
    - troubleshooting ..... 816
  - drive roller bearings
    - installing ..... 682
    - removing ..... 679
  - side draper drive roller
    - replacing ..... 716
  - drive rollers
    - feed draper ..... 676
    - installing ..... 678
    - removing ..... 676
  - drivelines
    - driveline guards
      - installing guard ..... 607
      - removing guard ..... 605
    - installing ..... 602
    - removing ..... 600
  - drives
    - header drive ..... 600
- E**
- EasyMove™ transport systems
    - adjusting wheels ..... 191
    - changing tow-bar hitch connection
      - pintle to clevis ..... 773
  - EasyMove™ transport systems (option)
    - changing tow-bar hitch connection
      - clevis to pintle ..... 775
  - electrical system ..... 599
    - replacing light bulbs ..... 599
  - sensors
    - auto header height control sensors ..... 292
    - reel speed sensor
      - replacing on AGCO combines ..... 758
      - replacing on CLAAS combines ..... 759
      - replacing on John Deere combines ..... 760
  - end deflector rods ..... 792
  - equipment servicing
    - end of season ..... 571
    - preseason ..... 571
  - extended center filler kit ..... 796
- F**
- feed auger configurations ..... 158
    - medium configuration ..... 167
    - narrow configuration ..... 164
    - ultra narrow configuration ..... 160
    - ultra wide configuration ..... 172
    - wide configuration ..... 169
  - feed auger flighting ..... 797
  - feed deck
    - checking link holder hooks ..... 694

## INDEX

feed deck pan		
lowering .....	691	
raising .....	693	
feed drapers		
adjusting speed .....	244	
draper tension		
checking, adjusting .....	674	
drive roller .....	676	
drive roller bearing		
installing .....	682	
removing .....	679	
drive rollers		
installing .....	678	
removing .....	676	
idler roller .....	682	
installing .....	685	
removing .....	682	
idler roller bearing		
replacing .....	688	
replacing feed draper .....	669	
fingers		
auger fingers .....	621	
adjusting finger timing .....	626	
checking finger timing .....	625	
installing .....	184, 623	
removing .....	181, 621	
flex float system		
flex frown limiter		
disable .....	225	
enable .....	225	
flex modes		
operating in flex mode .....	221	
flighting .....	174, 620	
installing .....	176, 179	
removing .....	174	
float		
header float		
changing float spring configuration and location .....	216	
checking and adjusting .....	210	
header float locks .....	221	
wing float locks		
locked .....	224	
unlocked .....	221	
float module kits .....	795	
float modules		
auger drive		
adjusting auger drive chain tension .....	618	
augers .....	612	
auger fingers .....	621	
adjusting finger timing .....	626	
checking finger timing .....	625	
installing .....	184, 623	
removing .....	181, 621	
auger to pan clearance .....	612	
optional feed auger flighting .....	797	
feed deck .....	669	
checking link holder hooks .....	694	
feed draper		
draper tension		
checking, adjusting .....	674	
drive roller .....	676	
installing .....	678	
removing .....	676	
drive roller bearing .....	679	
installing .....	682	
idler roller .....	682	
installing .....	685	
removing .....	682	
idler roller bearing		
replacing .....	688	
replacing feed draper .....	669	
flighting .....	174, 620	
setup .....	158	
stripper bars .....	188, 696	
installing .....	696	
removing .....	696	
unplugging feed draper .....	544	
floating crop dividers .....	788	
adjusting .....	276	
installing .....	273	
removing .....	272	
full interface filler kit .....	797	
<b>G</b>		
gearboxes		
completion gearbox		
adjusting chain tension .....	610	
lubricating completion gearbox .....	591	
adding oil .....	592	
changing oil .....	593	
checking oil level .....	591	
main gearbox		
adjusting chain tension .....	609	
lubricating main gearbox .....	589	
adding oil .....	590	
changing oil .....	590	
checking oil level .....	589	
greasing		
every 10 hours .....	574	
every 100 hours .....	580	
every 25 hours .....	575	
every 250 hours .....	582	
every 50 hours .....	576	
every 500 hours .....	584	
greasing procedure .....	585	
greasing schedule/records .....	568	
ground speed .....	242	



## INDEX

### H

header angle .....	232
header drapers, <i>See</i> drapers	
header drives.....	600
driveline guards	
installing .....	607
removing.....	605
gearboxes	
completion gearbox drive chain.....	610
main gearbox drive chain .....	609
header endshields .....	41
adjusting .....	44
checking .....	44
closing .....	42
installing.....	49
opening.....	41
removing .....	48
header float .....	209
headers .....	38
attachments.....	141
changing float spring configuration and location.....	216
checking and adjusting.....	210
float.....	209–210, 216
float locks .....	221
header angle	
adjusting from combine .....	234
header operation .....	37
operating variables.....	189
options.....	800
setup .....	141
transporting header	
attaching header to towing vehicle .....	546
on combine .....	545
towing .....	545
transporting precautions .....	546
hydraulics .....	595
changing oil filter	
Integrated Hydraulic System (IHS).....	597
Modular Hydraulic System (MHS) .....	597
checking hoses and lines .....	572
fittings	
O-ring boss – adjustable.....	826
O-ring boss – non-adjustable .....	827
O-ring face seal .....	828
tapered pipe thread fittings.....	829
hydraulic reservoir	
adding oil .....	595
changing oil .....	596
checking oil level .....	595
reservoir extension kit .....	798
safety.....	7

### I

inspections	
break-in inspections .....	570
integration kits	
Case IH combines	
contour wheels .....	193
John Deere X9 series combines	
assigning console buttons.....	68
assigning ground speed lever buttons.....	66
double tap.....	72
draper speed controls.....	71
wing level.....	70
John Deere X9 Series Combines	
assigning ground speed lever buttons.....	201
checking voltage range from combine cab.....	488
setting up header in CommandCenter™ .....	483
New Holland combines	
contour wheels .....	193

### J

John Deere combines	
attaching combine to header .....	112
detaching combine from header .....	119
replacing reel speed sensors .....	760

### K

knife drive boxes	
changing oil.....	667
checking mounting bolts.....	667
checking oil level.....	666
knife drive systems .....	666
knife drive box.....	666
knife speed information .....	245
knife drives .....	245
knife guards and hold-down	
double-knife	
FD245 pointed guard configuration.....	639
knifehead shields.....	664
installing.....	664
knives.....	629
spare knife location .....	633
troubleshooting .....	811

### L

light bulbs	
replacing .....	599
lodged crop reel finger kits.....	790
lubrication.....	574
lubrication and servicing	
auger drive chains .....	587

## INDEX

greasing procedure.....	585
header drive completion gearbox	
changing oil .....	593
checking oil level .....	591
lubricating gearbox .....	591
header drive main gearbox	
changing oil .....	590
checking oil level .....	589
lubricating gearbox .....	589
reel drive chain.....	587

## M

maintenance and servicing.....	567
ContourMax™	
end play.....	766
lubricating .....	764
feed drapers	
checking and adjusting tension.....	674
lubrication intervals.....	574
maintenance requirements.....	568
maintenance safety .....	5
maintenance schedule .....	568
servicing	
break-in inspections .....	570
end of season.....	571
preparing the machine.....	567
preseason.....	571
maintenance schedule/records .....	568
metric bolts	
torque specifications .....	823
model numbers	
records.....	xiv

## N

New Holland combines	
10 V adapter .....	300
New Holland CR/CX/CH combines	
attaching combine to header .....	123
detaching combine from header .....	128

## O

operating modes	
flex mode .....	221
rigid mode .....	224
options .....	787
ContourMax™ .....	761
adjusting wheels with foot switch .....	192
end play.....	766
leveling wheel height.....	204, 762
lubricating .....	764
crop delivery .....	787

end deflector rods (end delivery).....	792
feed auger flighting.....	797
stripper bar kit .....	799
upper cross auger .....	789
cutterbars .....	794
rock retarder kit .....	794
vertical knife kit.....	793
float modules .....	795
10 V sensor adapter kits.....	795
crop deflector kits.....	795
extended center filler kit .....	796
full interface filler kit .....	797
hydraulic reservoir extension kit.....	798
lateral tilt .....	798
plug kits .....	798
headers .....	800
reel	
plastic finger kits .....	804
steel finger kits .....	804
stabilizer wheels .....	805
sunflower attachment kit .....	791
knifehead shields .....	664
installing .....	664
reel drive sprockets .....	240
rice divider rods.....	289
transport systems.....	770
owner/operator responsibilities .....	37

## P

pick-up reels.....	720, 749
centering .....	727
fore-aft position.....	252
adjusting .....	253
repositioning cylinders.....	253
reel cam	
adjusting reel cam.....	263
settings and guidelines .....	261
reel clearance	
measuring .....	720
reel drive systems .....	749
covers.....	49
reel drives	
drive sprockets.....	752
optional for special conditions .....	240
reel endshields .....	738
reel fingers.....	729
installing plastic fingers.....	731
installing steel fingers .....	730
removing plastic fingers .....	730
removing steel fingers .....	729
reel frown.....	727
reel height .....	247
checking and adjusting sensor.....	248
replacing sensor .....	251

## INDEX

<ul style="list-style-type: none"> <li>reel safety props ..... 39               <ul style="list-style-type: none"> <li>disengaging ..... 40</li> <li>engaging ..... 39</li> </ul> </li> <li>reel speed ..... 240</li> <li>reel tine pitch ..... 261</li> <li>reel-to-cutterbar clearance ..... 720               <ul style="list-style-type: none"> <li>adjusting ..... 724</li> </ul> </li> <li>replacing reel speed sensors ..... 758               <ul style="list-style-type: none"> <li>AGCO combines ..... 758</li> <li>Challenger® combines ..... 758</li> <li>Gleaner® combines ..... 758</li> <li>IDEAL™ series combines ..... 758</li> <li>Massey Ferguson® combines ..... 758</li> </ul> </li> <li>tine tube bushings ..... 732</li> <li>troubleshooting ..... 814</li> <li>plug kits ..... 798</li> <li>pointed knife guards and hold-down               <ul style="list-style-type: none"> <li>double knife                   <ul style="list-style-type: none"> <li>FD240 pointed knife guard configuration ..... 637</li> <li>FD241 pointed knife guard configuration ..... 638</li> <li>FD250 pointed knife guard configuration ..... 640</li> </ul> </li> <li>double-knife pointed guard configuration FD235                   <ul style="list-style-type: none"> <li>..... 636</li> </ul> </li> </ul> </li> <li>product overview ..... 27</li> </ul>	<ul style="list-style-type: none"> <li>reel fore-aft sensors               <ul style="list-style-type: none"> <li>CLAAS Lexion 6000 series combines                   <ul style="list-style-type: none"> <li>calibrating ..... 379</li> </ul> </li> <li>CLAAS Lexion 7000 series combines                   <ul style="list-style-type: none"> <li>calibrating ..... 379</li> </ul> </li> <li>CLAAS Lexion 8000 series combines                   <ul style="list-style-type: none"> <li>calibrating ..... 379</li> </ul> </li> <li>CLAAS Trion 600 series combines                   <ul style="list-style-type: none"> <li>calibrating ..... 379</li> </ul> </li> <li>CLAAS Trion 700 series combines                   <ul style="list-style-type: none"> <li>calibrating ..... 379</li> </ul> </li> </ul> </li> <li>reel frown ..... 727</li> <li>reel height sensor               <ul style="list-style-type: none"> <li>CLAAS Lexion 6000 series combines                   <ul style="list-style-type: none"> <li>calibrating ..... 379</li> </ul> </li> <li>CLAAS Lexion 7000 series combines                   <ul style="list-style-type: none"> <li>calibrating ..... 379</li> </ul> </li> <li>CLAAS Lexion 8000 series and combines                   <ul style="list-style-type: none"> <li>calibrating ..... 379</li> </ul> </li> <li>CLAAS Trion 600 series combines                   <ul style="list-style-type: none"> <li>calibrating ..... 379</li> </ul> </li> <li>CLAAS Trion 700 series combines                   <ul style="list-style-type: none"> <li>calibrating ..... 379</li> </ul> </li> </ul> </li> <li>reel safety props ..... 39               <ul style="list-style-type: none"> <li>disengaging ..... 40</li> <li>engaging ..... 39</li> </ul> </li> <li>reel speeds ..... 240               <ul style="list-style-type: none"> <li>chain position ..... 757</li> </ul> </li> <li>reels, <i>See</i> pick-up reels               <ul style="list-style-type: none"> <li>checking and adjusting fore-aft position sensor                   <ul style="list-style-type: none"> <li>orientation ..... 259</li> </ul> </li> <li>checking fore-aft position sensor voltage ..... 258</li> </ul> </li> <li>rice divider rods ..... 289               <ul style="list-style-type: none"> <li>rice divider rod kit ..... 790</li> </ul> </li> <li>rigid modes               <ul style="list-style-type: none"> <li>operating in rigid mode ..... 224</li> </ul> </li> <li>rock retarder kit ..... 794</li> <li>Rostselmash combines               <ul style="list-style-type: none"> <li>attaching combine to header ..... 133</li> <li>detaching combine from header ..... 137</li> </ul> </li> </ul>
<b>R</b>	
<ul style="list-style-type: none"> <li>recommended fluids and lubricants ..... 845</li> <li>reel clearance               <ul style="list-style-type: none"> <li>measuring ..... 720</li> </ul> </li> <li>reel drive systems               <ul style="list-style-type: none"> <li>adjusting reel shape ..... 727</li> <li>dual sprocket (optional)                   <ul style="list-style-type: none"> <li>installing ..... 755</li> <li>removing ..... 753</li> </ul> </li> <li>endshield supports                   <ul style="list-style-type: none"> <li>replacing ..... 747</li> <li>replacing at inboard cam end ..... 741</li> <li>replacing at inboard tail end ..... 744</li> <li>replacing at outboard cam end ..... 739</li> <li>replacing at outboard tail end ..... 743</li> </ul> </li> <li>reel drive chain                   <ul style="list-style-type: none"> <li>loosening ..... 749</li> <li>tightening ..... 750</li> </ul> </li> <li>reel drive cover                   <ul style="list-style-type: none"> <li>installing ..... 51</li> <li>removing ..... 49</li> </ul> </li> <li>reel drive single sprocket                   <ul style="list-style-type: none"> <li>installing ..... 753</li> <li>removing ..... 752</li> </ul> </li> <li>tine tube bushings                   <ul style="list-style-type: none"> <li>installing ..... 735</li> <li>removing ..... 732</li> </ul> </li> </ul> </li> <li>reel fingers ..... 729</li> <li>reel fore-aft positions, <i>See</i> pick-up reels</li> </ul>	
<b>S</b>	
	<ul style="list-style-type: none"> <li>safety ..... 1               <ul style="list-style-type: none"> <li>alert symbols ..... 1</li> <li>daily start-up checks ..... 57</li> <li>general safety ..... 3</li> <li>header safety props ..... 38</li> <li>hydraulic safety ..... 7</li> <li>maintenance safety ..... 5</li> <li>operational safety ..... 38</li> <li>reel safety props ..... 39</li> <li>safety sign decals ..... 12                   <ul style="list-style-type: none"> <li>installing decals ..... 12</li> <li>safety decal locations ..... 13</li> </ul> </li> </ul> </li> </ul>

## INDEX

understanding decals.....	19
signal words.....	2
welding precautions .....	8
safety props .....	38
sensors	
auto header height control sensor .....	292
checking and adjusting fore-aft position sensor orientation .....	259
checking fore-aft position sensor voltage .....	258
reel height	
checking and adjusting.....	248
reel speed sensor	
replacing on AGCO combines .....	758
replacing on Challenger® combines .....	758
replacing on CLAAS combines .....	759
replacing on Gleaner® combines .....	758
replacing on IDEAL™ series combines.....	758
replacing on John Deere combines.....	760
replacing on Massey Ferguson® combines .....	758
serial numbers	
locations.....	xiv
records.....	xiv
service intervals	
lubrication .....	574
servicing, <i>See</i> maintenance and servicing	
settings	
optimizing headers for canola .....	152
recommended header settings .....	141
recommended reel settings .....	152
short knife guards and hold-down	
double knife	
short knife guard configuration – 12.5 m (41 ft.).....	655
short knife guard configuration – all except 12.5 m (41 ft.).....	654
shutting down procedures .....	59
side draper systems	
adjusting side draper deck height.....	701
adjusting side draper tension .....	703
inspecting draper roller bearing.....	707
installing side draper drive roller.....	717
installing side draper idler roller .....	712
installing side drapers .....	700
removing side draper drive roller .....	714
removing side draper idler roller.....	707
removing side drapers .....	698
replacing drive roller bearing.....	716
replacing idler roller bearing .....	709
skid shoes .....	207
<i>See also</i> cutting on the ground	
adjusting inner skid shoes.....	207
adjusting outer skid shoes .....	208
spare knives .....	633
specifications	
header and float module specifications.....	29

header dimensions .....	32
torque specifications .....	823
speeds.....	245
feed draper speed.....	244
ground speed .....	242
reel speed.....	240
side draper speed.....	243
adjusting .....	243
sprockets .....	752
adjusting reel drive chain tension.....	749
optional reel drive sprocket .....	240
stabilizer wheels	
adjusting .....	190
kits .....	805
start-up	
daily checks.....	57
stripper bars.....	188, 799
installing.....	696
removing.....	696
sunflower attachment .....	791

## T

tire inflation/pressures .....	772
torque specifications.....	823
metric bolt specifications.....	823
cast aluminum.....	825
O-ring boss hydraulic fittings – adjustable.....	826
O-ring boss hydraulic fittings – non-adjustable .....	827
O-ring face seal fittings .....	828
tapered pipe thread fittings .....	829
transport bolts.....	770
tow-bars	
attaching .....	562
removing .....	548
removing from storage.....	561
storing .....	551
towing the header .....	545
attaching to towing vehicle .....	546
converting from field to transport.....	557
moving wheels	
front (left) wheels to transport position.....	558
rear (right) wheels to transport position .....	559
converting from transport to field .....	547
moving wheels	
front (left) wheels to field position .....	552
rear (right) wheels to field position.....	555
removing tow-bar .....	548
removing tow-bar from storage.....	561
storing tow-bar.....	551
moving left outboard wheel from transport to working position .....	547
transport systems.....	770
checking assembly bolt torque .....	770
checking wheel bolt torque.....	770

## INDEX

converting from field to transport .....	557
moving wheels	
front (left) wheels to transport position.....	558
rear (right) wheels to transport position .....	559
converting from transport to field .....	547
moving wheels	
front (left) wheels to field position .....	552
rear (right) wheels to field position.....	555
removing tow-bar .....	548
removing tow-bar from storage.....	561
storing tow-bar.....	551
moving left outboard wheel from transport to working position .....	547
tire inflation/pressures.....	772
transporting header.....	545
on combine .....	545
troubleshooting .....	809
CLAAS multicoupler error codes.....	821
crop loss at cutterbar .....	809
cutting action and knife components .....	811
cutting edible beans .....	818
header and drapers .....	816
reel delivery .....	814

## U

upper cross augers.....	265
adjusting position.....	265
kits .....	789

## V

vertical knife kits .....	793
---------------------------	-----

## W

welding precautions.....	8
wheels and tires	
checking bolt torque.....	761, 770
stabilizer wheels .....	805
tire inflation/pressures.....	772
wing balance	
checking and adjusting wing balance .....	226



# Recommended Fluids and Lubricants

Ensure that your machine operates at top efficiency by using clean fluids and lubricants only.

- Use clean containers to handle all fluids and lubricants.
- Store fluids and lubricants in an area protected from dust, moisture, and other contaminants.

Lubricant	Specification	Description	Use	Capacities
<b>Grease</b>	SAE multi-purpose	High-temperature extreme-pressure (EP) performance with 1% max. molybdenum disulphide (NLGI Grade 2) lithium base	As required unless otherwise specified	—
		High-temperature extreme-pressure (EP) performance with 10% max. molybdenum disulphide (NLGI Grade 2) lithium base	Driveline slip-joints	—
<b>Gear lubricant</b>	SAE 85W-140	API service class GL-5	Knife drive box	1.5 liters (1.6 quarts)
			Main gearbox	2.75 liters (2.9 quarts)
			Completion gearbox	2.25 liters (2.4 quarts)
<b>Hydraulic oil</b>	<p>Single grade trans-hydraulic oil. Viscosity at 60.1 cSt @ 40°C (104°F) Viscosity at 9.5 cSt @ 100°C (212°F)</p> <p>Recommended Brands:</p> <ul style="list-style-type: none"> <li>• Petro-Canada Duratran</li> <li>• John Deere Hy-Gard J20C</li> <li>• CNH Hy-Tran Ultratractor</li> <li>• CNH Hy-Tran Multitractor</li> <li>• AGCO Power Fluid 821 XL</li> </ul>	Lubricant trans / hydraulic oil	Header drive systems reservoir	95 liters (25.1 US gallons)
<b>Chain oil</b>	Chain oil with a viscosity of 100–150 sCt at 40°C (104°F) or mineral oil SAE 20W-50 that has no detergents or solvents	Chain oil is formulated to provide good wear protection and resistance to foaming. It protects the chain and drive sprockets against wear.	Reel drive chain	—

# MacDon®

**CUSTOMERS**  
**MacDon.com**

**DEALERS**  
**Portal.MacDon.com**

Trademarks of products are the marks of their  
respective manufacturers and/or distributors.

Printed in Canada