

Step 1: Preadjustments

- Park the combine on a level surface, and ensure the combine feeder house is level. Use the bubble level on the float module.
- Ensure combine tires are equally inflated.
- Adjust header so cutterbar is 250 mm (10 in.) off the ground (A).
- Set the header angle hydraulic cylinder to D on indicator (B).
- Set the reel fore-aft to 6 on reel arm fore-aft indicator (C).

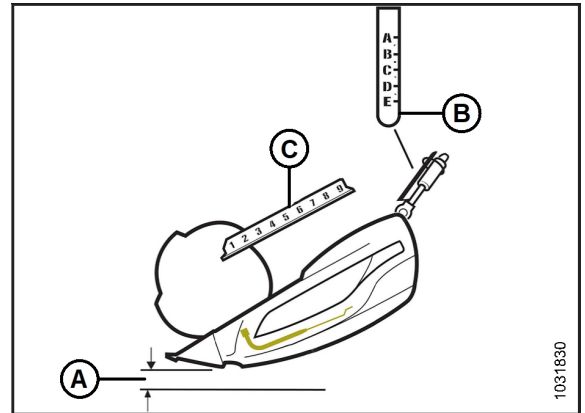

Figure 1: Header – Side View

- Lower the reel completely, shut down the combine, and remove the key from the combine ignition.
- Place both header float locks (A) in unlocked (lowered) position (left side float lock shown).
- If equipped, set stabilizer/transport wheels to the fully raised position.
- Ensure all accessories are installed. Added weight will affect float performance.

NOTE:

Read your operator’s manual and complete all the preadjustment tasks before setting the header float.

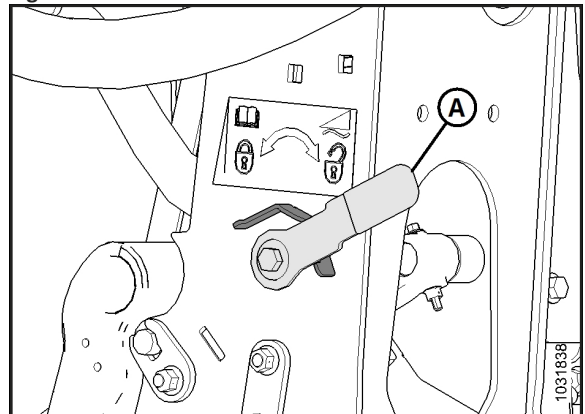

Figure 2: Float Unlocked – Left Side

Step 2: Checking Header Float

- On the left side of the header, lift float setting lever (A) by hand to remove slack.
- Fully engage the flat end of multi-tool (B) on the float setting lever. The multi-tool should be angled toward the front of the float module.
- Pull multi-tool (B) toward the back of the float module until lever (A) is locked in place and will not return to its original position.
- Move the header up and down by hand several times to reduce the effect of friction.
- Remove the multi-tool and repeat on the opposite side.



WARNING

Once the float setting lever has been set, remove the multi-tool from the lever IMMEDIATELY. If the lever falls to its starting position while the multi-tool is engaged with it, injury can occur.

- On the left side of the float module, inspect smaller float setting indicator (FSI) (A). Arm (B) on the FSI should point to the number 2.
 - If the FSI points to a value higher than 2, the header is too heavy.
 - If the FSI points to a value lower than 2, the header is too light.

NOTE: The larger numbers (C) indicate the float height while operating the header in the field.

NOTE: If necessary, adjust the float values to suit crop and field conditions. For more information, refer to the header operator’s manual.

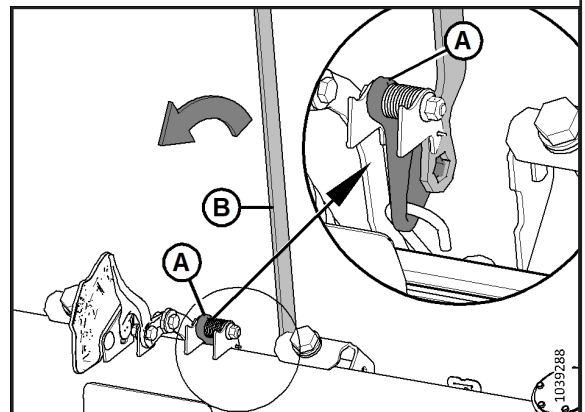

Figure 3: Checking Float – Left Rear View

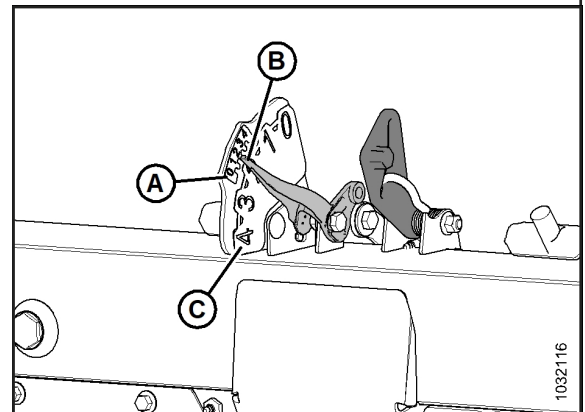

Figure 4: Checking Float – Left Rear View

Step 3: Setting Header Float

- a. Loosen bolts (C), and rotate spring locks (B).
 - To decrease header weight, turn both adjustment bolts (A) equally clockwise (decreasing the value on the FSI).
 - To increase header weight, turn both adjustment bolts (A) equally counterclockwise (increasing the value on the FSI).

NOTE: Ensure the FSI values are equal on both sides.

- b. After adjustment, lift the end of the header by hand and recheck the FSI reading.

NOTE: If an adequate header float cannot be achieved using all the available adjustments, an optional heavy duty spring is available. See your MacDon Dealer or refer to the parts catalog for ordering information.

- c. Once the float adjustment is complete, lock adjustment bolts (A) with spring locks (B). Ensure that bolt heads (A) are engaged and tighten bolts (C) to secure the spring locks.
- d. Use the combine to fully lower the header. The left and right float setting levers will return to their original positions.



WARNING

Do NOT use the multi-tool to release the float setting lever. Using the multi-tool to release the float setting lever can result in injury.

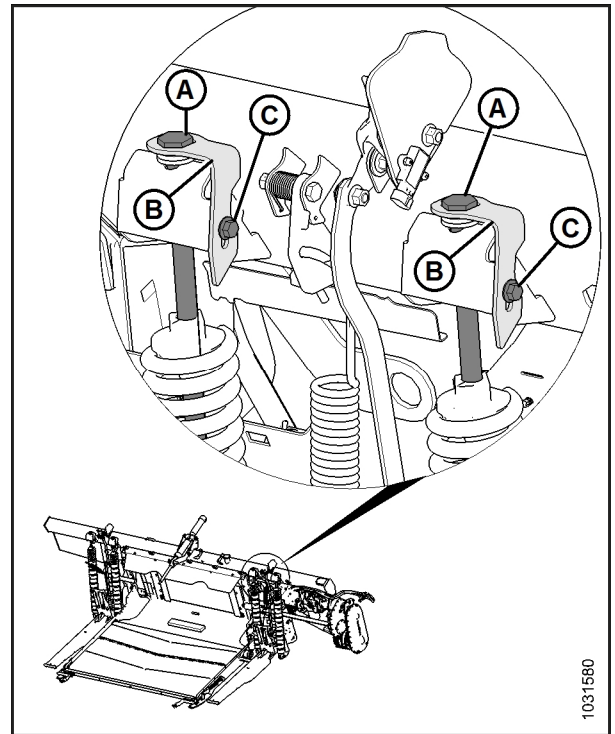

Figure 5: Float Adjustment Bolts – Left Side Shown

1031580

NOTE: For a list of recommended fluids, lubricants, and capacities, refer to the inside back cover of the D2 Series / FM200 Operator's Manual.

Table 1.1: Break-In Inspections

Time	Item
First 5 Minutes	Check hydraulic oil level in reservoir (check after first run-up and after the hydraulic hoses have filled with oil).
First 5 Hours	Check for loose hardware and tighten to the required torque value. Check knife drive belts tension (check the tension periodically for the first 50 hours).
First 10 Hours	Check auger drive chain tension. Check knife drive box mounting bolts.
First 50 Hours	Change float module gearbox oil. Change float module hydraulic oil filter. Change knife drive box lubricant. Check gearbox chain tension. Check deck height adjustment.

Table 2.1: Ongoing Maintenance Intervals

Time	Service
Every 10 Hours (or Daily)	Check hydraulic hoses and lines for leaks. Check knife sections, guards, and hold-downs. Check tire pressure. Check link holder hooks. Lubricate knife (except in sandy conditions). Grease feed/center draper roller bearings.
Every 25 Hours	Check hydraulic oil level. Grease knifeheads (one pump).
Every 50 Hours	Grease driveline and driveline universals. Grease upper cross auger center support and U-joint.
NOTE: For service beyond 50 hours, refer to the D2 Series / FM200 Operator's Manual.	

Subject to change without notice