

M155

Self-Propelled Windrower

Operator's Manual

215014 Revision A

Original Instruction

M155 Self-Propelled Windrower featuring Dual Direction® and Ultra Glide® suspension.



Published July 2019

California Proposition 65 Warning

Diesel engine exhaust and some of its constituents are known to the State of California to cause cancer, birth defects, and other reproductive harm. Battery posts, terminals, and related accessories contain lead and lead components. Wash hands after handling.

© 2019 MacDon Industries, Ltd.

The information in this publication is based on the information available and in effect at the time of printing. MacDon Industries, Ltd. makes no representation or warranty of any kind, whether expressed or implied, with respect to the information in this publication. MacDon Industries, Ltd. reserves the right to make changes at any time without notice.

Whole Body and Hand-Arm Vibration Levels

The weighted root mean square acceleration, to which the whole body is subjected, ranges from 0.57 to 1.06 m/s^2 as measured on a representative machine during typical operations and analyzed in accordance with ISO 5008.

During the same operations, the weighted root means square hand-arm vibration was less than 1.45 m/s^2 when analyzed in accordance with ISO 5349. These acceleration values depend on the roughness of the ground, the speeds at which the windrower is operated, the operator's experience, weight, and driving habits.

Noise Levels

The A-weighted sound pressure levels inside the operator's station ranged from 70.1 to 73.1 dB(A) as measured on several representative machines in accordance with ISO 5131. The sound pressure level depends upon the engine speed and load, field and crop conditions, and the type of platform used.

Declaration of Conformity

Figure 1: Declaration of Conformity (Page 1 of 2)

 <h2 style="text-align: center;">EC Declaration of Conformity</h2>	
<p>[1] MacDon MacDon Industries Ltd. 680 Moray Street, Winnipeg, Manitoba, Canada R3J 3S3</p>	<p>[4] As per Shipping Document</p> <p>[5] May 9, 2019</p> <p>[6] _____ Christoph Martens Product Integrity</p>
<p>[2] Windrower</p> <p>[3] MacDon M Series</p>	

EN	BG	CZ	DA
<p>We, [1] Declare, that the product: Machine Type: [2] Name & Model: [3] Serial Number(s): [4] fulfils all the relevant provisions of the Directive 2006/42/EC. Harmonized standards used, as referred to in Article 7(2): EN ISO 4254-1:2013 EN ISO 4254-7:2009 Place and date of declaration: [5] Identity and signature of the person empowered to draw up the declaration: [6] Name and address of the person authorized to compile the technical file: Benedikt von Riedesel General Manager, MacDon Europe GmbH Hagenauer Straße 59 65203 Wiesbaden (Germany) bvonriedesel@macdon.com</p>	<p>Ние, [1] декларираме, че следният продукт: Тип машина: [2] Наименование и модел: [3] Серийен номер(а) [4] отговаря на всички приложими разпоредби на директива 2006/42/ЕО. Използвани са следните хармонизирани стандарти според чл. 7(2): EN ISO 4254-1:2013 EN ISO 4254-7:2009 Място и дата на декларацията: [5] Име и подпис на лицето, упълномощено да изготви декларацията: [6] Име и адрес на лицето, упълномощено да състави техническия файл: Бенедикт фон Рийдзел Управител, MacDon Europe GmbH Hagenauer Straße 59 65203 Wiesbaden (Германия) bvonriedesel@macdon.com</p>	<p>My, [1] Prohlašujeme, že produkt: Typ zařízení: [2] Název a model: [3] Sériové(á) číslo(a): [4] splňuje všechna relevantní ustanovení směrnice 2006/42/EC. Byly použity harmonizované standardy, jak je uvedeno v článku 7(2): EN ISO 4254-1:2013 EN ISO 4254-7:2009 Místo a datum prohlášení: [5] Identita a podpis osoby oprávněné k vydání prohlášení: [6] Jméno a adresa osoby oprávněné k vyplnění technického souboru: Benedikt von Riedesel generální ředitel, MacDon Europe GmbH Hagenauer Straße 59 65203 Wiesbaden (Německo) bvonriedesel@macdon.com</p>	<p>Vi, [1] erklærer, at produktet: Maskintype [2] Navn og model: [3] Serienummer (-numre): [4] Opfylder alle bestemmelser i direktiv 2006/42/EF. Anvendte harmoniserede standarder, som henviser til i paragraf 7(2): EN ISO 4254-1:2013 EN ISO 4254-7:2009 Sted og dato for erklæringen: [5] Identitet på og underskrift fra den person, som er bemyndiget til at udarbejde erklæringen: [6] Navn og adresse på den person, som er bemyndiget til at udarbejde den tekniske fil: Benedikt von Riedesel Direktør, MacDon Europe GmbH Hagenauer Straße 59 D-65203 Wiesbaden (Tyskland) bvonriedesel@macdon.com</p>
DE	ES	ET	FR
<p>Wir, [1] Erklären hiermit, dass das Produkt: Maschinentyp: [2] Name & Modell: [3] Seriennummer (n): [4] alle relevanten Vorschriften der Richtlinie 2006/42/EG erfüllt. Harmonisierte Standards wurden, wie in folgenden Artikeln angegeben, verwendet 7(2): EN ISO 4254-1:2013 EN ISO 4254-7:2009 Ort und Datum der Erklärung: [5] Name und Unterschrift der Person, die dazu befugt ist, die Erklärung auszustellen: [6] Name und Anschrift der Person, die dazu berechtigt ist, die technischen Unterlagen zu erstellen: Benedikt von Riedesel General Manager, MacDon Europe GmbH Hagenauer Straße 59 65203 Wiesbaden bvonriedesel@macdon.com</p>	<p>Nosotros [1] declaramos que el producto: Tipo de máquina: [2] Nombre y modelo: [3] Números de serie: [4] cumple con todas las disposiciones pertinentes de la directriz 2006/42/EC. Se utilizaron normas armonizadas, según lo dispuesto en el artículo 7(2): EN ISO 4254-1:2013 EN ISO 4254-7:2009 Lugar y fecha de la declaración: [5] Identidad y firma de la persona facultada para draw redactar la declaración: [6] Nombre y dirección de la persona autorizada para elaborar el expediente técnico: Benedikt von Riedesel Gerente general - MacDon Europe GmbH Hagenauer Straße 59 65203 Wiesbaden (Alemania) bvonriedesel@macdon.com</p>	<p>Meie, [1] deklareerime, et toode Seadme tüüp: [2] Nimi ja mudel: [3] Seerianumbrid: [4] vastab kõigile direktiivi 2006/42/EÜ asjakohastele sätetele. Kasutatud on järgnevald harmoniseeritud standardeid, millele on viidatud ka punktis 7(2): EN ISO 4254-1:2013 EN ISO 4254-7:2009 Deklaratsiooni koht ja kuupäev: [5] Deklaratsiooni koostamiseks volitatud isiku nimi ja allkiri: [6] Tehnilise dokumendi koostamiseks volitatud isiku nimi ja aadress: Benedikt von Riedesel Peadirektor, MacDon Europe GmbH Hagenauer Straße 59 65203 Wiesbaden (Saksamaa) bvonriedesel@macdon.com</p>	<p>Nous soussignés, [1] Déclarons que le produit : Type de machine : [2] Nom et modèle : [3] Numéro(s) de série : [4] Est conforme à toutes les dispositions pertinentes de la directive 2006/42/EC. Utilisation des normes harmonisées, comme indiqué dans l'Article 7(2): EN ISO 4254-1:2013 EN ISO 4254-7:2009 Lieu et date de la déclaration : [5] Identité et signature de la personne ayant reçu le pouvoir de rédiger cette déclaration : [6] Nom et adresse de la personne autorisée à constituer le dossier technique : Benedikt von Riedesel Directeur général, MacDon Europe GmbH Hagenauer Straße 59 65203 Wiesbaden (Allemagne) bvonriedesel@macdon.com</p>

<p><i>The Harvesting Specialists</i></p>		<p>1030035</p>
--	---	----------------

Figure 2: Declaration of Conformity (Page 2 of 2)

EC Declaration of Conformity			
IT	HU	LT	LV
<p>Noi, [1] Dichiariamo che il prodotto: Tipo di macchina: [2] Nome e modello: [3] Numero(i) di serie: [4] soddisfa tutte le disposizioni rilevanti della direttiva 2006/42/CE. Utilizzo degli standard armonizzati, come indicato nell'Articolo 7(2): EN ISO 4254-1:2013 EN ISO 4254-7:2009 Luogo e data della dichiarazione: [5] Nome e firma della persona autorizzata a redigere la dichiarazione: [6] Nome e persona autorizzata a compilare il file tecnico: Benedikt von Riedesel General Manager, MacDon Europe GmbH Hagenauer Straße 59 65203 Wiesbaden (Germania) bvonriedesel@macdon.com</p>	<p>Mi, [1] Ezennel kijelentjük, hogy a következő termék: Gép típusa: [2] Név és modell: [3] Számszám(ok): [4] teljesíti a következő irányelv összes vonatkozó előírásait: 2006/42/EK. Az alábbi harmonizált szabványok kerültek alkalmazásra a 7(2) cikkely szerint: EN ISO 4254-1:2013 EN ISO 4254-7:2009 A nyilatkozattétel ideje és helye: [5] Azon személy kiléte és aláírása, aki jogosult a nyilatkozat elkészítésére: [6] Azon személy neve és aláírása, aki felhatalmazott a műszaki dokumentáció összeállítására: Benedikt von Riedesel Vezérigazgató, MacDon Europe GmbH Hagenauer Straße 59 65203 Wiesbaden (Németország) bvonriedesel@macdon.com</p>	<p>Mes, [1] Pareiškiami, kad šis produktas: Mašinos tipas: [2] Pavadinimas ir modelis: [3] Serijos numeris (-iai): [4] atitinka taikomos reikalavimus pagal Direktyvą 2006/42/EB. Naudojami harmonizuoti standartai, kai nurodoma straipsnyje 7(2): EN ISO 4254-1:2013 EN ISO 4254-7:2009 Deklaracijos vieta ir data: [5] Asmens tapatybės duomenys ir parašas asmens, įgalioto sudaryti šią deklaraciją: [6] Vardas ir pavardė asmens, kuris įgaliotas sudaryti šį techninį failą: Benedikt von Riedesel Generalinis direktorius, MacDon Europe GmbH Hagenauer Straße 59 65203 Wiesbaden (Vokietija) bvonriedesel@macdon.com</p>	<p>Mēs, [1] Deklarējam, ka produkts: Mašīnas tips: [2] Nosaukums un modelis: [3] Sērijas numurs(-i): [4] Atbilst visām būtiskajām Direktīvas 2006/42/EK prasībām. Piemēroti šādi saskaņotie standarti, kā minēts 7. panta 2. punktā: EN ISO 4254-1:2013 EN ISO 4254-7:2009 Deklarācijas parakstīšanas vieta un datums: [5] Tās personas vārds, uzvārds un paraksts, kas ir pilnvarota sagatavot šo deklarāciju: [6] Tās personas vārds, uzvārds un adrese, kas ir pilnvarota sastādīt tehnisko dokumentāciju: Benedikts fon Rīdizels Generāldirektors, MacDon Europe GmbH Hagenauer Straße 59 65203 Wiesbaden (Vācija) bvonriedesel@macdon.com</p>
<p>Wij, [1] Verklaren dat het product: Machinetype: [2] Naam en model: [3] Serienummer(s): [4] voldoet aan alle relevante bepalingen van de Richtlijn 2006/42/EC. Geharmoniseerde normen toegepast, zoals vermeld in Artikel 7(2): EN ISO 4254-1:2013 EN ISO 4254-7:2009 Plaats en datum van verklaring: [5] Naam en handtekening van de bevoegde persoon om de verklaring op te stellen: [6] Naam en adres van de geautoriseerde persoon om het technisch dossier samen te stellen: Benedikt von Riedesel Algemeen directeur, MacDon Europe GmbH Hagenauer Straße 59 65203 Wiesbaden (Duitsland) bvonriedesel@macdon.com</p>	<p>My niżej podpisani, [1] Oświadczamy, że produkt: Typ urządzenia: [2] Nazwa i model: [3] Numer seryjny/numery seryjne: [4] spełnia wszystkie odpowiednie przepisy dyrektywy 2006/42/WE. Zastosowaliśmy następujące (zharmonizowane) normy zgodnie z artykułem 7(2): EN ISO 4254-1:2013 EN ISO 4254-7:2009 Data i miejsce oświadczenia: [5] Imię i nazwisko oraz podpis osoby upoważnionej do przygotowania deklaracji: [6] Imię i nazwisko oraz adres osoby upoważnionej do przygotowania dokumentacji technicznej: Benedikt von Riedesel Dyrektor generalny, MacDon Europe GmbH Hagenauer Straße 59 65203 Wiesbaden (Niemcy) bvonriedesel@macdon.com</p>	<p>Nós, [1] Declaramos, que o produto: Tipo de máquina: [2] Nome e Modelo: [3] Número(s) de Série: [4] cumpre todas as disposições relevantes da Directiva 2006/42/CE. Normas harmonizadas aplicadas, conforme referido no Artigo 7(2): EN ISO 4254-1:2013 EN ISO 4254-7:2009 Local e data da declaração: [5] Identidade e assinatura da pessoa autorizada a elaborar a declaração: [6] Nome e endereço da pessoa autorizada a compilar o ficheiro técnico: Benedikt von Riedesel Gerente Geral, MacDon Europa Ltda. Hagenauer Straße 59 65203 Wiesbaden (Alemanha) bvonriedesel@macdon.com</p>	<p>Noi, [1] Declarăm, că următorul produs: Tipul mașinii: [2] Denumirea și modelul: [3] Număr (numere) serie: [4] corespunde tuturor dispozițiilor esențiale ale directivei 2006/42/EC. Au fost aplicate următoarele standarde armonizate conform articolului 7(2): EN ISO 4254-1:2013 EN ISO 4254-7:2009 Data și locul declarației: [5] Identitatea și semnătura persoanei împuternicite pentru întocmirea declarației: [6] Numele și semnătura persoanei autorizate pentru întocmirea cărții tehnice: Benedikt von Riedesel Manager General, MacDon Europe GmbH Hagenauer Straße 59 65203 Wiesbaden (Germania) bvonriedesel@macdon.com</p>
<p>Mi, [1] Izjavljujemo da proizvod Tip mašine: [2] Naziv i model: [3] Serijski broj(ovi): [4] Ispunjava sve relevantne odredbe direktive 2006/42/EC. Korišćeni su usklađeni standardi kao što je navedeno u članu 7(2): EN ISO 4254-1:2013 EN ISO 4254-7:2009 Datum i mesto izdavanja deklaracije: [5] Identitet i potpis lica ovlašćenog za sastavljanje deklaracije: [6] Ime i adresa osobe ovlašćene za sastavljanje tehničke datoteke: Benedikt von Riedesel Generalni direktor, MacDon Europe GmbH Hagenauer Straße 59 65203 Wiesbaden (Nemačka) bvonriedesel@macdon.com</p>	<p>Vi, [1] Intygat att produkten: Maskintyp: [2] Namn och modell: [3] Serienummer: [4] uppfyller alla relevanta villkor i direktivet 2006/42/EG. Harmoniserade standarder används, såsom anges i artikel 7(2): EN ISO 4254-1:2013 EN ISO 4254-7:2009 Plats och datum för intyget: [5] Identitet och signatur för person med befogenhet att upprätta intyget: [6] Namn och adress för person behörig att upprätta den tekniska dokumentationen: Benedikt von Riedesel Administrativ chef, MacDon Europe GmbH Hagenauer Straße 59 65203 Wiesbaden (Tyskland) bvonriedesel@macdon.com</p>	<p>Mi, [1] izjavijamo, da izdelek: Vrsta stroja: [2] Ime in model: [3] Serijska/-e številka/-e: [4] ustreza vsem zadevnim določbam Direktive 2006/42/ES. Uporabljeni usklajeni standardi, kot je navedeno v členu 7(2): EN ISO 4254-1:2013 EN ISO 4254-7:2009 Kraj in datum izjave: [5] Istovetnost in podpis osebe, opolnomočene za pripravo izjave: [6] Ime in naslov osebe, pooblaščenca za pripravo tehnične datoteke: Benedikt von Riedesel Generalni direktor, MacDon Europe GmbH Hagenauer Straße 59 65203 Wiesbaden (Nemčija) bvonriedesel@macdon.com</p>	<p>My, [1] týmto prehlasujeme, že tento výrobok: Typ zariadenia: [2] Názov a model: [3] Výrobné číslo: [4] splňa príslušné ustanovenia a základné požiadavky smernice č. 2006/42/ES. Použité harmonizované normy, ktoré sa uvádzajú v Článku č. 7(2): EN ISO 4254-1:2013 EN ISO 4254-7:2009 Miesto a dátum prehlásenia: [5] Meno a podpis osoby oprávnenej vypracovať toto prehlásenie: [6] Meno a adresa osoby oprávnenej zostaviť technický súbor: Benedikt von Riedesel Generálny riaditeľ MacDon Europe GmbH Hagenauer Straße 59 65203 Wiesbaden (Nemecko) bvonriedesel@macdon.com</p>

1030036

Introduction

This manual contains information on the MacDon M155 Self-Propelled Windrower which, when coupled with one of MacDon's auger, rotary, or draper headers, provides a package designed to cut and lay in windrows a variety of grain, hay, and specialty crops.

The M155 Windrower features Dual Direction®, meaning that the windrower can be driven in cab-forward or engine-forward mode. Right and left designations are therefore determined by the operator's position, facing the direction of travel. This manual uses the terms right cab-forward, left cab-forward, right engine-forward, and left engine-forward when referencing specific locations on the machine.

Use this manual as your first source of information about the machine. Use the Table of Contents and the Index to guide you to specific areas. Study the Table of Contents to familiarize yourself with how the material is organized.

When setting up the machine or making adjustments, review and follow the recommended machine settings in all relevant MacDon publications. Failure to do so may compromise the machine function and machine life and may result in a hazardous situation.

If you follow the instructions given here, your M155 Windrower will work well for many years.

Use this manual in conjunction with your header operator's manual.

A manual storage case is provided in the cab. Keep this manual handy for frequent reference and to pass on to new Operators or Owners. Call your Dealer if you need assistance, information, or additional copies of this manual.

Unless otherwise noted, use the standard torque values provided in Chapter *8.1 Recommended Torques, page 467* of this document.

CAREFULLY READ ALL THE MATERIAL PROVIDED BEFORE ATTEMPTING TO USE THE MACHINE.

MacDon provides warranty for Customers who operate and maintain their equipment as described in this manual. A copy of the MacDon Industries Limited Warranty Policy, which explains this warranty, should have been provided to you by your Dealer. Damage resulting from any of the following conditions will void the warranty:

- Accident
- Misuse
- Abuse
- Improper maintenance or neglect
- Abnormal or extraordinary use of the machine
- Failure to use the machine, equipment, component, or part in accordance with the manufacturer's instructions

NOTE: Keep your MacDon publications up-to-date. The most current version can be downloaded from our website www.macdon.com or from our Dealer-only site (<https://portal.macdon.com>) (login required).

NOTE:

This document is available in English and Russian, and can be ordered from MacDon, downloaded from the MacDon Dealer Portal (<https://portal.macdon.com>) (login required), or downloaded from the MacDon international website (<http://www.macdon.com/world>).

List of Revisions

At MacDon, we're continuously making improvements; occasionally these improvements impact product documentation. The following list provides an account of major changes from the previous version of this document.

Section	Summary of Change	Internal Use Only
<i>1.2 Signal Words, page 2</i>	Added description for IMPORTANT and NOTE signal words appearing throughout this manual.	Tech Pubs
<i>1.11 Safety Sign Locations, page 13</i>	Updated topic and illustration to show lift linkage decals.	ECN 58047
<i>1.12 Understanding Safety Signs, page 17</i>	Updated topic to include safety decals MD #306179/306181 and MD #306180/306181.	ECN 58047
<i>3.19.12 Calibrating the Swath Compressor Sensor, page 130</i>	Updated cab display module (CDM) illustrations.	Tech Pubs
<i>4.2.3 Header Functions, page 158</i>	Updated illustration and legend for MY2020.	ECN 57956
<i>4.3.2 Break-In Period, page 160</i>	Added note about optimal hydraulic temperature prior to moving the ground speed lever (GSL) out of Park.	Tech Pubs, Safety
<i>Starting the Engine, page 162</i>	Added note about optimal hydraulic temperature prior to moving the GSL out of Park.	Tech Pubs, Safety
<i>Engine Warm-Up, page 164</i>	Added note about optimal hydraulic temperature prior to moving the GSL out of Park.	Tech Pubs, Safety
<i>4.4.1 Engaging and Disengaging Header Safety Props, page 196</i>	Updated illustrations to show new header lock decals.	ECN 58047
<i>4.5.1 Attaching Header Boots, page 218</i>	Updated illustrations to show new header lock decals.	ECN 58047
<i>Attaching a D Series or D1 Series Draper Header – Hydraulic Center-Link with Optional Self-Alignment, page 219</i>	Updated illustrations to show new header lock decals.	ECN 58047
<i>Attaching a D Series or D1 Series Draper Header – Hydraulic Center-Link without Self-Alignment, page 225</i>	Updated illustrations to show new header lock decals.	ECN 58047
<i>Detaching a D Series or D1 Series Draper Header – Hydraulic Center-Link, page 236</i>	Updated illustrations to show new header lock decals.	ECN 58047
<i>Detaching a D Series Header – Mechanical Center-Link, page 240</i>	Updated illustrations to show new header lock decals.	ECN 58047
<i>Attaching an A Series Header – Hydraulic Center-Link with Optional Self-Alignment, page 243</i>	Updated illustrations to show new header lock decals.	ECN 58047
<i>Attaching an A Series Header – Hydraulic Center-Link without Self-Alignment, page 249</i>	Updated illustrations to show new header lock decals.	ECN 58047
<i>Attaching an A Series Header – Mechanical Center-Link, page 254</i>	Updated illustrations to show new header lock decals.	ECN 58047
<i>Detaching an A Series Header – Hydraulic Center-Link, page 260</i>	Updated illustrations to show new header lock decals.	ECN 58047
<i>Detaching an A Series Header – Mechanical Center-Link, page 263</i>	Updated illustrations to show new header lock decals.	ECN 58047

Section	Summary of Change	Internal Use Only
<i>Attaching an R Series or R1 Series Header – Hydraulic Center-Link with Optional Self-Alignment, page 267</i>	Updated illustrations to show new header lock decals.	ECN 58047
<i>Attaching an R Series or R1 Series Header – Hydraulic Center-Link without Optional Self-Alignment, page 272</i>	Updated illustrations to show new header lock decals.	ECN 58047
<i>Attaching an R Series or R1 Series Header – Mechanical Center-Link, page 277</i>	Updated illustrations to show new header lock decals.	ECN 58047
<i>Detaching an R Series or R1 Series Header – Hydraulic Center-Link, page 282</i>	Updated illustrations to show new header lock decals.	ECN 58047
<i>Detaching an R Series or R1 Series Header – Mechanical Center-Link, page 285</i>	Updated illustrations to show new header lock decals.	ECN 58047
<i>Checking Coolant Level, page 365</i>	Updated illustration of engine coolant tank.	Tech Pubs
<i>Draining and Cleaning the Coolant Tank, page 366</i>	Updated illustration of engine coolant tank.	Tech Pubs
<i>Fuse Box Decal, page 411</i>	Updated fuse box decal for MY2020.	ECN 58157
<i>7.3.1 Draper Header Case Drain Kit, page 463</i>	Updated kit's bundle number to MD #B6154.	ECN 54755
Throughout manual	Removed content related to Double Windrow Attachment (DWA) from the manual. DWA does not apply to MY2020 M155 machines.	ECN 57956

Serial Numbers

Record the model number, model year, and serial number of the windrower and engine on the lines below.

The windrower serial number plate (A) is located on the left side of the main frame near the walking beam.

Windrower model number _____
Windrower serial number _____
Year of manufacture _____

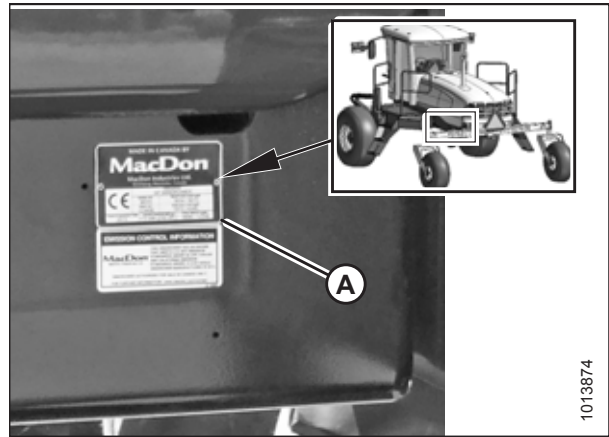

Figure 3: Machine Serial Number Location

The engine serial number plate (A) is located on top of the engine cylinder head cover.

Engine serial number _____
Date of manufacture _____

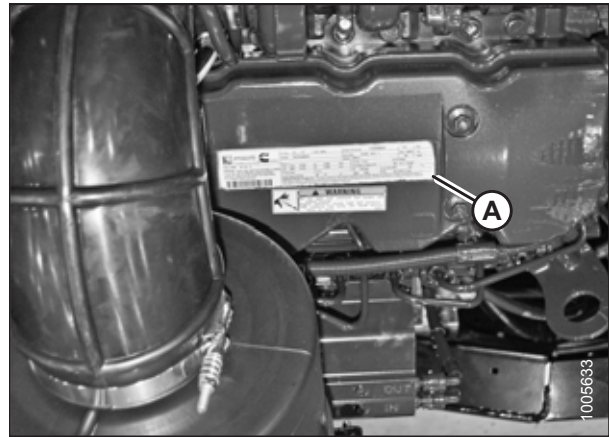

Figure 4: Engine Serial Number Location

TABLE OF CONTENTS

Declaration of Conformity	i
Introduction	iii
List of Revisions.....	iv
Serial Numbers.....	vi
Chapter 1: Safety	1
1.1 Safety Alert Symbols	1
1.2 Signal Words	2
1.3 General Safety	3
1.4 Maintenance Safety	5
1.5 Hydraulic Safety	6
1.6 Tire Safety.....	7
1.7 Battery Safety	8
1.8 Welding Precautions	9
1.9 Engine Safety.....	10
1.9.1 High-Pressure Rail	11
1.9.2 Engine Electronics	11
1.10 Safety Signs	12
1.10.1 Installing Safety Decals	12
1.11 Safety Sign Locations	13
1.12 Understanding Safety Signs	17
Chapter 2: Product Overview	25
2.1 Definitions	25
2.2 Specifications.....	28
2.3 Windrower Dimensions	32
2.4 Component Location.....	35
Chapter 3: Operator's Station	39
3.1 Operator Console	39
3.2 Operator Presence System	41
3.2.1 Header Drive.....	41
3.2.2 Engine and Transmission	41
3.3 Operator's Seat Adjustments	42
3.3.1 Adjusting Fore-Aft Position	42
3.3.2 Adjusting Seat Suspension and Height	42
3.3.3 Adjusting Vertical Dampener.....	43
3.3.4 Adjusting Armrest	43
3.3.5 Adjusting Fore-Aft Isolator Lock	44
3.3.6 Adjusting Seat Tilt	44
3.3.7 Adjusting Armrest Angle.....	45
3.3.8 Adjusting Lumbar Support	45

TABLE OF CONTENTS

3.4	Training Seat	46
3.5	Using Seat Belts	47
3.6	Adjusting Steering Column	48
3.7	Exterior Lighting	49
3.7.1	Auto-Road Lighting.....	49
3.7.2	Cab-Forward Lighting.....	50
3.7.3	Engine-Forward Lighting.....	52
3.7.4	HID Auxiliary Lighting (Optional)	53
3.8	Windshield Wipers	54
3.9	Rearview Mirrors.....	55
3.10	Cab Temperature.....	56
3.10.1	Heater Shut-Off.....	56
3.10.2	Air Distribution	56
3.10.3	Climate Controls	57
Refrigerant Oil	57	
3.11	Interior Lights.....	58
3.12	Emergency Exit.....	59
3.13	Operator Amenities.....	60
3.14	Radio	62
3.14.1	AM/FM Radio	62
3.14.2	Mounting the Antenna	62
3.15	Horn.....	64
3.16	Engine Controls and Gauges	65
3.17	Windrower Controls	66
3.18	Header Controls	68
3.18.1	Header Drive Switch	68
3.18.2	Header Drive Reverse Button	68
3.18.3	Ground Speed Lever Header Switches.....	69
Display Selector Switch	70	
Header Position Switches.....	70	
Reel and Disc Speed Switches	71	
3.18.4	Console Header Switches.....	72
Deck Shift / Float Preset Switch.....	72	
3.19	Cab Display Module (CDM).....	73
3.19.1	Engine and Windrower Functions.....	73
3.19.2	Header Functions	74
3.19.3	Operating Screens	75
Ignition ON, Engine Not Running	75	
Engine Running – At Initial Start Up	75	
Engine-Forward, Engine Running	76	
Cab-Forward, Engine Running, Header Disengaged	76	
Cab-Forward, Engine Running, Header Engaged, Auger Header Index Switch OFF.....	77	
Cab-Forward, Engine Running, Header Engaged, Auger Header Index Switch ON	78	
Engine Running, Header Engaged, Auger Header	79	
Cab-Forward, Engine Running, Header Engaged, Draper Header, Index Switch OFF.....	80	

TABLE OF CONTENTS

Cab-Forward, Engine Running, Header Engaged, Draper Header Index Switch ON	81
Cab-Forward, Engine Running, Header Engaged, Rotary Header Installed	82
Miscellaneous Operational Information	83
3.19.4 Cab Display Module Warning and Alarms	84
Engine Warning Lights	84
Display Warnings and Alarms.....	85
3.19.5 Cab Display Module – Configuration Guidelines	87
3.19.6 Cab Display Module – Configuration Functions	88
3.19.7 Cab Display Options.....	89
Setting the Cab Display Language	90
Changing the Windrower Display Units.....	91
Adjusting the Cab Display Buzzer Volume.....	92
Adjusting the Cab Display Backlighting.....	93
Adjusting the Cab Display Contrast	94
3.19.8 Configuring the Windrower.....	95
Setting the Header Knife Speed.....	95
Setting the Knife Overload Speed	96
Setting the Rotary Disc Overload Speed.....	97
Setting the Hydraulic Overload Pressure	98
Setting the Header Index Mode.....	99
Setting the Return to Cut Mode	100
Setting the Auto Raise Height	101
Activating the Hydraulic Center-Link.....	102
Activating the Rotary Header Drive Hydraulics	103
Setting the Header Cut Width	104
Activating the Swath Compressor	105
Activating the Hay Conditioner.....	107
Displaying Reel Speed.....	108
Setting the Windrower’s Tire Size.....	109
Setting the Engine Intermediate Speed Control (ISC) RPM.....	110
Clearing Sub-Acres	111
3.19.9 Activating Cab Display Lockouts	112
Activating the Header Tilt Control Lockout	112
Activating the Header Float Control Lockout.....	114
Activating the Reel Fore-Aft Control Lockout	115
Activating the Draper Speed Control Lockout.....	117
Activating the Auger Speed Control Lockout.....	118
Activating Knife Speed Control Lockout	119
Activating Rotary Disc Speed Control Lockout.....	120
Activating the Reel Speed Control Lockout	121
3.19.10 Displaying Activated Cab Display Lockouts	122
3.19.11 Calibrating the Header Sensors	124
Calibrating the Header Height Sensor.....	124
Calibrating the Header Tilt Sensor.....	126
Calibrating the Header Float Sensors.....	128
3.19.12 Calibrating the Swath Compressor Sensor	130
3.19.13 Troubleshooting Windrower Problems	131
Displaying the Windrower and Engine Error Codes	131
Switching the Installed Header Sensors ON or OFF.....	133
Displaying Header Sensor Input Signals.....	135
Forcing a Header ID	136
3.19.14 Troubleshooting Header Problems.....	138

TABLE OF CONTENTS

Testing the Header Up/Down Activate Function Using the Cab Display Module	138
Testing the Reel Up/Down Activate Function Using the Cab Display Module	140
Testing the Header Tilt Activate Function Using the Cab Display Module	141
Testing the Knife Drive Circuit Using the Cab Display Module	143
Testing the Draper Drive Circuit Activate Function Using the Cab Display Module	145
Testing the Reel Drive Circuit Activate Function Using the Cab Display Module.....	147
Testing the Rotary Disc Drive Circuit Activate Function Using the Cab Display Module	149
Testing the Reel Fore-Aft Activate Function Using the Cab Display Module	151
Activating the Hydraulic Purge Using the Cab Display Module.....	152
3.19.15 Engine Error Codes	154
3.19.16 Cab Display Module and Windrower Control Module Fault Codes	154
Chapter 4: Operation	155
4.1 Owner/Operator Responsibilities	155
4.2 Symbol Definitions.....	156
4.2.1 Engine Functions.....	156
4.2.2 Windrower Operating Symbols.....	157
4.2.3 Header Functions.....	158
4.3 Operating the Windrower	159
4.3.1 Operational Safety	159
4.3.2 Break-In Period.....	160
4.3.3 Preseason Checks / Annual Service	161
Air Conditioning Compressor Coolant Cycling	161
4.3.4 Daily Checks and Maintenance	162
4.3.5 Engine Operation	162
Starting the Engine	162
Engine Warm-Up	164
Engine Intermediate Speed Control.....	164
Shutting down the Engine	165
Filling the Fuel Tank	166
Engine Temperature.....	167
Engine Oil Pressure	168
Cab Display Module Voltage Display	168
Engine Warning Lights	168
4.3.6 Driving the Windrower.....	169
Entering and Exiting the Windrower.....	170
Driving Forward in Cab-Forward Mode	172
Driving Reverse in Cab-Forward Mode.....	173
Driving Forward in Engine-Forward Mode	174
Driving in Reverse in Engine-Forward Mode	175
Spin Turning	176
Stopping	177
4.3.7 Adjusting Caster Tread Width.....	178
4.3.8 Transporting	180
Driving on the Road	180
Towing Header with Windrower.....	183
Towing the Windrower – Emergency.....	193
Engaging and Disengaging Final Drives	194
4.3.9 Storing the Windrower	195
4.4 Operating with a Header.....	196

TABLE OF CONTENTS

4.4.1 Engaging and Disengaging Header Safety Props	196
4.4.2 Using Header Float	198
Float Operating Guidelines	198
Checking Float	199
Float Options	201
4.4.3 Levelling the Header	203
4.4.4 Header Drive	206
Engaging and Disengaging the Header	206
Reversing the Header	207
4.4.5 Adjusting Header Angle	208
Checking Self-Locking Center-Link Hook	209
4.4.6 Controlling Cutting Height	211
4.4.7 Return to Cut	211
Programming the Return to Cut Feature	212
Using the Return to Cut Feature	213
4.4.8 Auto Raise Height	214
Programming the Auto Raise Height Feature	214
Using the Auto Raise Height Feature	215
4.4.9 Header Drop Rate	215
4.4.10 Swath Compressor (Option)	215
Using the Swath Compressor	216
4.5 Attaching and Detaching Headers	218
4.5.1 Attaching Header Boots	218
4.5.2 Attaching a D Series or D1 Series Header	219
Attaching a D Series or D1 Series Draper Header – Hydraulic Center-Link with Optional Self-Alignment	219
Attaching a D Series or D1 Series Draper Header – Hydraulic Center-Link without Self-Alignment	225
Attaching a D Series or D1 Series Draper Header – Mechanical Center-Link	231
4.5.3 Detaching a D Series or D1 Series Draper Header	236
Detaching a D Series or D1 Series Draper Header – Hydraulic Center-Link	236
Detaching a D Series Header – Mechanical Center-Link	240
4.5.4 Attaching an A Series Header	243
Attaching an A Series Header – Hydraulic Center-Link with Optional Self-Alignment	243
Attaching an A Series Header – Hydraulic Center-Link without Self-Alignment	249
Attaching an A Series Header – Mechanical Center-Link	254
4.5.5 Detaching an A Series Header	260
Detaching an A Series Header – Hydraulic Center-Link	260
Detaching an A Series Header – Mechanical Center-Link	263
4.5.6 Attaching an R Series or R1 Series Header	267
Attaching an R Series or R1 Series Header – Hydraulic Center-Link with Optional Self-Alignment	267
Attaching an R Series or R1 Series Header – Hydraulic Center-Link without Optional Self-Alignment	272
Attaching an R Series or R1 Series Header – Mechanical Center-Link	277
4.5.7 Detaching an R Series or R1 Series Header	282
Detaching an R Series or R1 Series Header – Hydraulic Center-Link	282
Detaching an R Series or R1 Series Header – Mechanical Center-Link	285
4.6 Operating with a D Series or D1 Series Header	289
4.6.1 Configuring Hydraulics	289
4.6.2 Header Position	290

TABLE OF CONTENTS

4.6.3 Adjusting the Reel Fore-Aft Position	290
4.6.4 Adjusting the Reel Height	290
4.6.5 Reel Speed.....	291
Setting Reel to Ground Speed	291
Setting the Reel Only Speed.....	293
4.6.6 Draper Speed	294
Setting Draper to Ground Speed.....	294
Setting Minimum Draper Speed	295
Setting Draper Index	296
Setting Draper Speed Independent of Ground Speed	298
4.6.7 Knife Speeds	299
4.6.8 Deck Shift Control	300
Deck Shift.....	300
Setting Float Options with Deck Shift	301
4.7 Operating with an A Series Header	303
4.7.1 Auger Speed	303
Auger Speed on A30D Headers.....	303
Setting the Auger Speed on A40D Headers	303
4.7.2 Reel Speed.....	304
Reel Speed on A30D Headers.....	304
Reel Speed on A40D Headers.....	304
4.7.3 Knife Speed.....	309
4.8 Operating with an R Series or R1 Series Header	310
4.8.1 Disc Speed	311
Setting Disc Speed	311
Chapter 5: Maintenance and Servicing.....	313
5.1 Preparation for Servicing	313
5.2 Engine Compartment Hood	314
5.2.1 Opening Hood – Lower Position.....	314
5.2.2 Closing Hood – Lower Position	315
5.2.3 Opening Hood – Highest Position.....	316
5.2.4 Closing Hood – Highest Position	317
5.3 Maintenance Platforms	318
5.3.1 Opening Platforms – Standard Position	318
5.3.2 Closing Platforms – Standard Position.....	319
5.3.3 Opening Platforms – Major Service Position	320
5.3.4 Closing Platforms – Major Service Position	322
5.4 Windrower Lubrication.....	323
5.4.1 Lubricating the Windrower	323
5.4.2 Lubrication Points	324
5.5 Operator’s Station	325
5.5.1 Seat Belts	325
5.5.2 Safety Systems	325
Checking Operator Presence System	325
Checking Engine Interlock	326

TABLE OF CONTENTS

5.5.3 Ground Speed Lever Adjustments	327
Adjusting Ground Speed Lever Lateral Movement	327
Adjusting Ground Speed Lever Fore-Aft Movement	327
5.5.4 Steering Adjustments.....	328
Checking Steering Link Pivots.....	328
Checking and Adjusting Steering Chain Tension.....	330
5.5.5 Park Brake	330
5.6 Cab Suspension Limit Straps	331
5.7 Heating, Ventilating, and Air Conditioning System	332
5.7.1 Fresh Air Intake Filter	332
Removing Fresh Air Filter	332
Inspecting and Cleaning Fresh Air Filter Element	333
Installing Fresh Air Filter	333
5.7.2 Servicing the Return Air Cleaner/Filter	334
Cleaning Return Air Cleaner/Filter	335
5.7.3 Air Conditioning Condenser	336
5.7.4 Air Conditioning Evaporator Core.....	336
Removing Air Conditioning Cover	336
Cleaning Air Conditioning Evaporator Core.....	337
Installing Air Conditioning Cover.....	337
5.7.5 Air Conditioning Compressor.....	338
Servicing the Air Conditioning Compressor	338
5.8 Engine	339
5.8.1 General Engine Inspection	339
5.8.2 Turning the Engine Manually.....	339
5.8.3 Engine Oil	341
Checking Engine Oil Level.....	341
Changing Engine Oil	343
Draining Engine Oil	343
Replacing Engine Oil Filter	344
Adding Engine Oil	344
5.8.4 Engine Air Intake System	345
Air Filter Restriction Indicator	345
Removing Primary Air Filter	346
Installing Primary Air Filter	348
Cleaning Engine Air Filter Primary Element.....	350
Removing and Installing Secondary Air Filter	351
Air Precleaner	352
5.8.5 Fuel System	353
Replacing Fuel Tank Vent Filter	353
Maintaining Fuel Filters	354
Removing Primary Fuel Filter	355
Installing Primary Fuel Filter	357
Removing Secondary Fuel Filter.....	359
Installing Secondary Fuel Filter.....	359
Draining Fuel Tank	360
Fuel/Water Separator.....	362
Removing Water from Fuel System	362
System Priming	363
Priming Fuel System	363

TABLE OF CONTENTS

5.8.6 Engine Cooling System	364
Inspecting Radiator Cap	364
Checking Engine Coolant Strength	365
Checking Coolant Level	365
Changing Coolant	366
Draining and Cleaning the Coolant Tank	366
Adding Coolant	368
Maintaining Engine Cooling Box	369
Opening Cooler Box Screen	370
Charge Air Cooling	370
Cleaning Screens and Coolers	371
Cleaning Cooler Box Components	372
Adjusting Screen Cleaner Rotor to Screen Clearance	374
Closing Cooler Box Screen	374
5.8.7 Gearbox	375
Checking Lubricant Level and Adding Lubricant	375
Changing Lubricant	376
5.8.8 Exhaust System.....	377
5.8.9 Belts	377
Tensioning Alternator/Fan Belt	377
Replacing Fan Belt	377
Tensioning Air Conditioner Compressor Belt.....	379
Replacing Air Conditioner Compressor Belt	379
5.8.10 Engine Speed.....	380
Throttle Adjustment.....	380
5.9 Electrical System	381
5.9.1 Preventing Electrical System Damage	381
5.9.2 Battery.....	382
Maintaining Batteries	382
Battery Main Disconnect Switch	382
Charging the Batteries	383
Boosting the Batteries	385
Adding Electrolyte to the Batteries	386
Removing Batteries.....	387
Installing Batteries	388
Connecting Batteries	389
5.9.3 Headlights – Engine-Forward	390
Replacing Headlight Bulb	390
Aligning Headlights	393
5.9.4 Field Lights – Cab-Forward.....	395
Adjusting Field Lights.....	395
Replacing Field Light Bulb.....	396
5.9.5 Floodlights – Forward	397
Adjusting Forward Floodlights.....	397
Replacing Bulb in Cab-Forward Flood Light.....	397
5.9.6 High-Intensity Discharge (HID) Auxiliary Lighting (Optional – MD #B5596).....	399
Adjusting High-Intensity Discharge (HID) Auxiliary Lights (if Installed).....	399
Replacing High-Intensity Discharge (HID) Auxiliary Lights (if Installed)	400
5.9.7 Floodlights – Rear	403
Adjusting Rear Floodlights.....	403
Replacing Bulb in Rear Flood Light	403
5.9.8 Replacing Bulbs in Red and Amber Lights	405

TABLE OF CONTENTS

5.9.9 Replacing Red Taillights	406
5.9.10 Replacing Beacon Lights	406
5.9.11 Replacing a Console Gauge Light	407
5.9.12 Replacing the Cabin Dome Light	408
5.9.13 Replacing the Ambient Light Fixture	408
5.9.14 Turn Signal Indicators	409
5.9.15 Circuit Breakers and Fuses	409
Accessing Circuit Breakers and Fuses	409
Checking and Replacing Fuses	410
Replacing Circuit Breakers and Relays	410
Fuse Box Decal	411
Inspecting and Replacing 125A Main Fuses	412
5.10 Hydraulic System	414
5.10.1 Checking and Filling Hydraulic Oil	415
5.10.2 Hydraulic Oil Cooler	416
5.10.3 Changing the Hydraulic Oil	416
5.10.4 Changing Hydraulic Oil Filters	417
Charge Oil Filter	417
Removing Charge Oil Filter	418
Installing Charge Oil Filter	418
Return Oil Filter	418
Removing Return Oil Filter	419
Installing Return Oil Filter	420
5.10.5 Header and Reel Hydraulics	421
Hoses and Lines	421
Pressure Compensator Valve	422
Flow Control Blocks	422
Adjusting Header Drop Rate	423
Adjusting Reel Drop Rate	423
5.10.6 Traction Drive Hydraulics	424
Checking Transmission Oil Pressure	425
Checking Charge Pump Pressure	425
5.11 Wheels and Tires	426
5.11.1 Traction Drive	426
Inflating Drive Wheel Tire	426
Tightening Drive Wheel Nuts	427
Lubricating Wheel Drive	427
Checking Wheel Drive Lubricant Level	427
Adding Wheel Drive Lubricant	428
Changing Wheel Drive Lubricant	429
Servicing Drive Wheel	430
Raising Drive Wheel	430
Removing Drive Wheel	431
Installing Drive Wheel	432
Lowering Drive Wheel	433
5.11.2 Caster Wheels	433
Inflating Caster Tire	433
Tightening Caster Wheel Nuts	434
Servicing Caster Wheels	435
Raising Caster Wheel – Formed and Forked	435
Lowering Caster Wheel – Formed and Forked	437

TABLE OF CONTENTS

Removing Forked Caster Wheel.....	437
Installing Forked Caster Wheel.....	438
Removing Formed Caster Wheel.....	439
Installing Formed Caster Wheel.....	439
Tightening Caster Wheel Anti-Shimmy Dampeners.....	440
Ballast Requirements.....	441
5.12 Maintenance Schedule.....	442
5.12.1 Maintenance Schedule/Record.....	443
Chapter 6: Troubleshooting.....	447
6.1 Engine Troubleshooting.....	447
6.2 Electrical Troubleshooting.....	451
6.3 Hydraulics Troubleshooting.....	452
6.4 Header Drive Troubleshooting.....	453
6.5 Traction Drive Troubleshooting.....	454
6.6 Steering and Ground Speed Control Troubleshooting.....	456
6.7 Cab Air Troubleshooting.....	457
6.8 Operator's Station Troubleshooting.....	460
Chapter 7: Options and Attachments.....	461
7.1 Cab.....	461
7.1.1 AM/FM Radio.....	461
7.1.2 Automated Steering Systems.....	461
7.1.3 High Intensity Discharge Auxiliary Lighting.....	461
7.1.4 Warning Beacons.....	461
7.1.5 Windshield Shades.....	461
7.2 Engine.....	462
7.2.1 Engine Block Heater.....	462
7.2.2 Engine Fan Air Baffle.....	462
7.3 Header Operation.....	463
7.3.1 Draper Header Case Drain Kit.....	463
7.3.2 Draper Header Reel Drive and Lift Plumbing.....	463
7.3.3 Header Drive Reverser.....	463
7.3.4 Hydraulic Center-Link.....	464
7.3.5 Light Header Flotation.....	464
7.3.6 Mechanical Center-Link.....	464
7.3.7 Pressure Sensor Kit.....	464
7.3.8 R1 Disc Drive Kit.....	464
7.3.9 R80 and R85 Rotary Header Drive Hydraulics – 4.0 m (13 ft.).....	464
7.3.10 Self-Aligning Center-Link.....	465
7.3.11 Spring with External Booster Spring.....	465
7.3.12 Spring with Internal Booster Spring.....	465
7.3.13 Swath Compressor.....	465
7.3.14 Swath Roller.....	465

TABLE OF CONTENTS

7.4 Transport	466
7.4.1 Lighting and Marking for Cab-Forward Road Travel	466
7.4.2 Towing Harness	466
7.4.3 Weight Box	466
Chapter 8: Reference	467
8.1 Recommended Torques	467
8.1.1 Torque Specifications	467
SAE Bolt Torque Specifications	467
Metric Bolt Specifications	469
Metric Bolt Specifications Bolting into Cast Aluminum	471
Flare-Type Hydraulic Fittings	472
O-Ring Boss Hydraulic Fittings – Adjustable	473
O-Ring Boss Hydraulic Fittings – Non-Adjustable	475
O-Ring Face Seal Hydraulic Fittings	476
Tapered Pipe Thread Fittings	477
8.2 Recommended Fuel, Fluids, and Lubricants	478
8.2.1 Storing Lubricants and Fluids	478
8.2.2 Fuel Specifications	478
8.2.3 Lubricants, Fluids, and System Capacities	479
8.2.4 Filter Part Numbers	480
8.3 Conversion Chart	481
8.4 Engine Error Codes	482
8.5 Cab Display Module Error Codes	494
Index	497
Lubricants, Fluids, and System Capacities	507

Chapter 1: Safety

1.1 Safety Alert Symbols

This safety alert symbol indicates important safety messages in this manual and on safety signs on the machine.

This symbol means:

- **ATTENTION!**
- **BECOME ALERT!**
- **YOUR SAFETY IS INVOLVED!**

Carefully read and follow the safety message accompanying this symbol.

Why is safety important to you?

- Accidents disable and kill
- Accidents cost
- Accidents can be avoided



Figure 1.1: Safety Symbol

1.2 Signal Words

Three signal words, **DANGER**, **WARNING**, and **CAUTION**, are used to alert you to hazardous situations. Two signal words, **IMPORTANT** and **NOTE**, identify non-safety related information. Signal words are selected using the following guidelines:

DANGER

Indicates an imminently hazardous situation that, if not avoided, will result in death or serious injury.

WARNING

Indicates a potentially hazardous situation that, if not avoided, could result in death or serious injury. It may also be used to alert against unsafe practices.

CAUTION

Indicates a potentially hazardous situation that, if not avoided, may result in minor or moderate injury. It may be used to alert against unsafe practices.

IMPORTANT:

Indicates a situation that, if not avoided, could result in a malfunction or damage to the machine.

NOTE:

Provides additional information or advice.

1.3 General Safety

CAUTION

The following general farm safety precautions should be part of your operating procedure for all types of machinery.

Protect yourself.

- When assembling, operating, and servicing machinery, wear all protective clothing and personal safety devices that could be necessary for job at hand. Do **NOT** take chances. You may need the following:
 - Hard hat
 - Protective footwear with slip-resistant soles
 - Protective glasses or goggles
 - Heavy gloves
 - Wet weather gear
 - Respirator or filter mask
- Be aware that exposure to loud noises can cause hearing impairment or loss. Wear suitable hearing protection devices such as earmuffs or earplugs to help protect against loud noises.



Figure 1.2: Safety Equipment

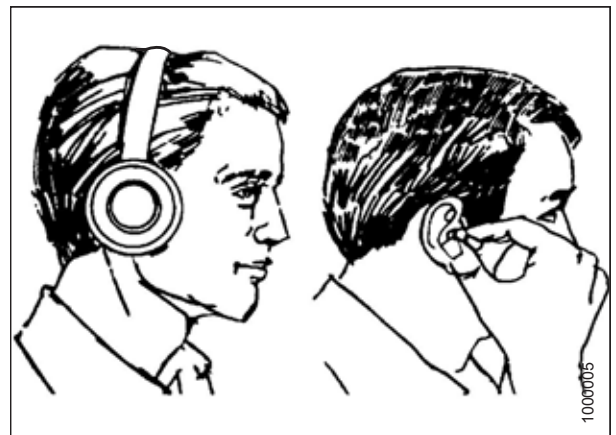

Figure 1.3: Safety Equipment

- Provide a first aid kit in case of emergencies.
- Keep a properly maintained fire extinguisher on the machine. Be familiar with its proper use.
- Keep young children away from machinery at all times.
- Be aware that accidents often happen when the operator is tired or in a hurry. Take time to consider safest way. **NEVER** ignore warning signs of fatigue.

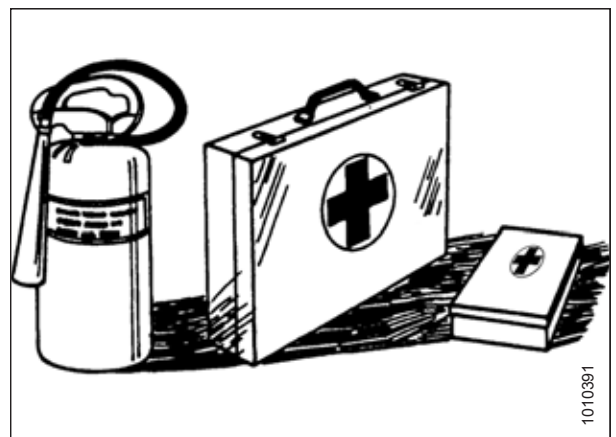

Figure 1.4: Safety Equipment

SAFETY

- Wear close-fitting clothing and cover long hair. **NEVER** wear dangling items such as scarves or bracelets.
- Keep all shields in place. **NEVER** alter or remove safety equipment. Make sure driveline guards can rotate independently of shaft and can telescope freely.
- Use only service and repair parts made or approved by equipment manufacturer. Substituted parts may not meet strength, design, or safety requirements.



Figure 1.5: Safety around Equipment

- Keep hands, feet, clothing, and hair away from moving parts. **NEVER** attempt to clear obstructions or objects from a machine while engine is running.
- Do **NOT** modify machine. Unauthorized modifications may impair machine function and/or safety. It may also shorten machine's life.
- To avoid injury or death from unexpected startup of machine, **ALWAYS** stop the engine and remove the key from the ignition before leaving the operator's seat for any reason.

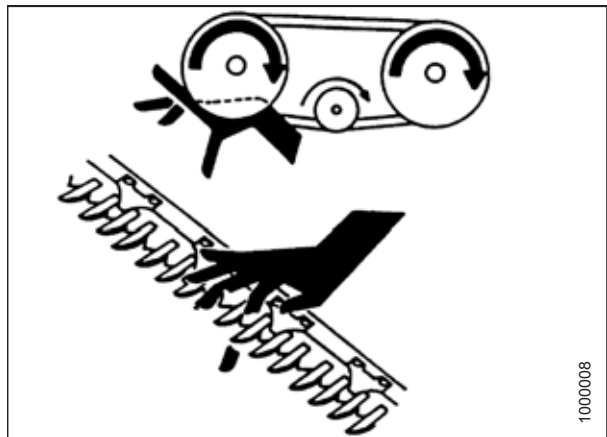

Figure 1.6: Safety around Equipment

- Keep service area clean and dry. Wet or oily floors are slippery. Wet spots can be dangerous when working with electrical equipment. Be sure all electrical outlets and tools are properly grounded.
- Keep work area well lit.
- Keep machinery clean. Straw and chaff on a hot engine is a fire hazard. Do **NOT** allow oil or grease to accumulate on service platforms, ladders, or controls. Clean machines before storage.
- **NEVER** use gasoline, naphtha, or any volatile material for cleaning purposes. These materials may be toxic and/or flammable.
- When storing machinery, cover sharp or extending components to prevent injury from accidental contact.



Figure 1.7: Safety around Equipment

1.4 Maintenance Safety

To ensure your safety while maintaining machine:

- Review operator’s manual and all safety items before operation and/or maintenance of machine.
- Place all controls in Neutral, stop the engine, set the park brake, remove the ignition key, and wait for all moving parts to stop before servicing, adjusting, and/or repairing.
- Follow good shop practices:
 - Keep service areas clean and dry
 - Be sure electrical outlets and tools are properly grounded
 - Keep work area well lit



Figure 1.8: Safety around Equipment

- Relieve pressure from hydraulic circuits before servicing and/or disconnecting machine.
- Make sure all components are tight and that steel lines, hoses, and couplings are in good condition before applying pressure to hydraulic systems.
- Keep hands, feet, clothing, and hair away from all moving and/or rotating parts.
- Clear area of bystanders, especially children, when carrying out any maintenance, repairs, or adjustments.
- Install transport lock or place safety stands under frame before working under machine.
- If more than one person is servicing machine at same time, be aware that rotating a driveline or other mechanically-driven component by hand (for example, accessing a lubricant fitting) will cause drive components in other areas (belts, pulleys, and knives) to move. Stay clear of driven components at all times.
- Wear protective gear when working on machine.
- Wear heavy gloves when working on knife components.

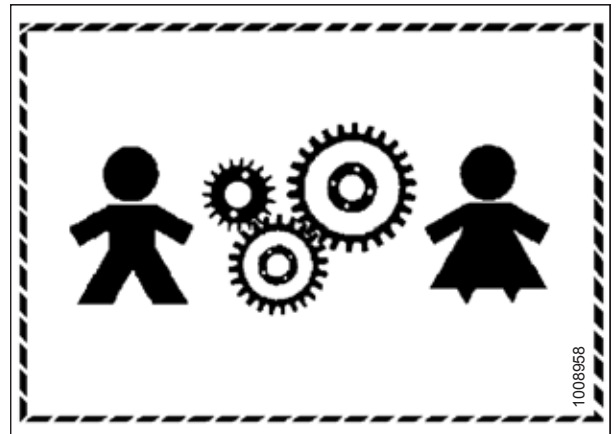

Figure 1.9: Equipment NOT Safe for Children



Figure 1.10: Safety Equipment

1.5 Hydraulic Safety

- Always place all hydraulic controls in Neutral before dismounting.
- Make sure that all components in hydraulic system are kept clean and in good condition.
- Replace any worn, cut, abraded, flattened, or crimped hoses and steel lines.
- Do **NOT** attempt any makeshift repairs to hydraulic lines, fittings, or hoses by using tapes, clamps, cements, or welding. The hydraulic system operates under extremely high-pressure. Makeshift repairs will fail suddenly and create hazardous and unsafe conditions.

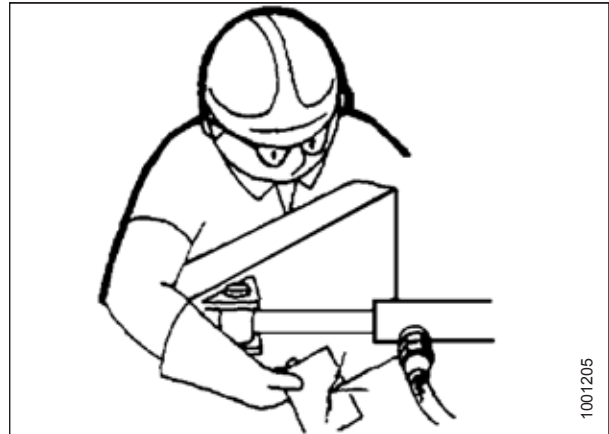

Figure 1.11: Testing for Hydraulic Leaks

- Wear proper hand and eye protection when searching for high-pressure hydraulic leaks. Use a piece of cardboard as a backstop instead of hands to isolate and identify a leak.
- If injured by a concentrated high-pressure stream of hydraulic fluid, seek medical attention immediately. Serious infection or toxic reaction can develop from hydraulic fluid piercing the skin.



Figure 1.12: Hydraulic Pressure Hazard

- Make sure all components are tight and steel lines, hoses, and couplings are in good condition before applying pressure to a hydraulic system.

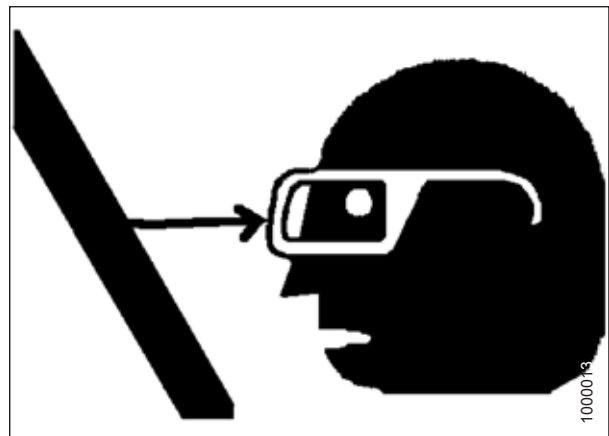

Figure 1.13: Safety around Equipment

1.6 Tire Safety

WARNING

- Service tires safely.
- A tire can explode during inflation which could cause serious injury or death.
- Follow proper procedures when mounting a tire on a wheel or rim. Failure to do so can produce an explosion that may result in serious injury or death.

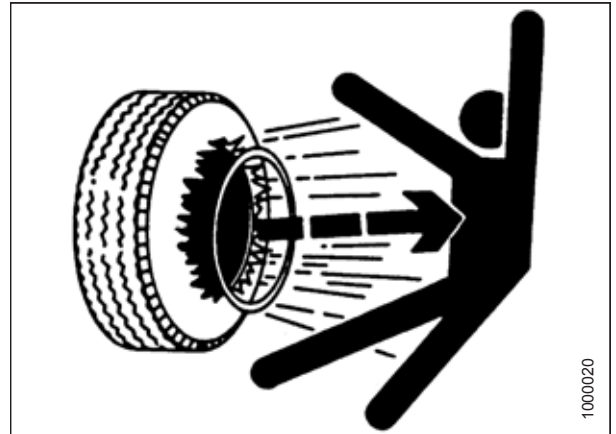

Figure 1.14: Overinflated Tire

WARNING

- Do NOT stand over tire. Use a clip-on chuck and extension hose.
- Do NOT exceed maximum inflation pressure indicated on tire label.
- Replace tires that have defects.
- Replace wheel rims that are cracked, worn, or severely rusted.
- Never weld a wheel rim.
- Never use force on an inflated or partially inflated tire.
- Make sure the tire is correctly seated before inflating to operating pressure.
- If the tire is not correctly positioned on the rim or is overinflated, the tire bead can loosen on one side causing air to escape at high speed and with great force. An air leak of this nature can thrust the tire in any direction, endangering anyone in area.
- Make sure all air is removed from the tire before removing the tire from the rim.
- Do NOT remove, install, or repair a tire on a rim unless you have proper equipment and experience to perform job. Take the tire and rim to a qualified tire repair shop.

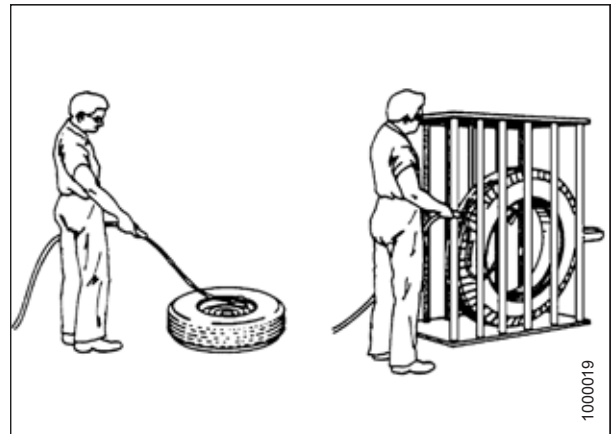

Figure 1.15: Safely Inflating Tire

1.7 Battery Safety

WARNING

- Keep all sparks and flames away from batteries; an explosive gas is given off by electrolyte.
- Ventilate when charging in enclosed space.



Figure 1.16: Safety around Batteries

WARNING

- Wear safety glasses when working near batteries.
- Do NOT tip batteries more than 45° to avoid electrolyte loss.
- Battery electrolyte causes severe burns. Avoid contact with skin, eyes, or clothing.
- Electrolyte splashed into eyes is extremely dangerous. Should this occur, force eye open, and flood with cool, clean water for 5 minutes. Call a doctor immediately.
- If electrolyte is spilled or splashed on clothing or body, neutralize it immediately with a solution of baking soda and water, then rinse with clear water.

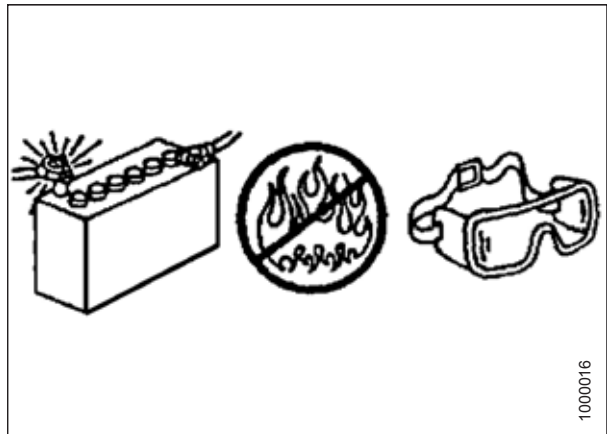

Figure 1.17: Safety around Batteries

WARNING

- To avoid injury from spark or short circuit, disconnect battery ground cable before servicing any part of electrical system.
- Do NOT operate engine with alternator or battery disconnected. With battery cables disconnected and engine running, a high voltage can be built up if terminals touch frame. Anyone touching frame under these conditions would be severely shocked.
- When working around storage batteries, remember that all of the exposed metal parts are live. Never lay a metal object across terminals because a spark or short circuit will result.
- Keep batteries out of reach of children.

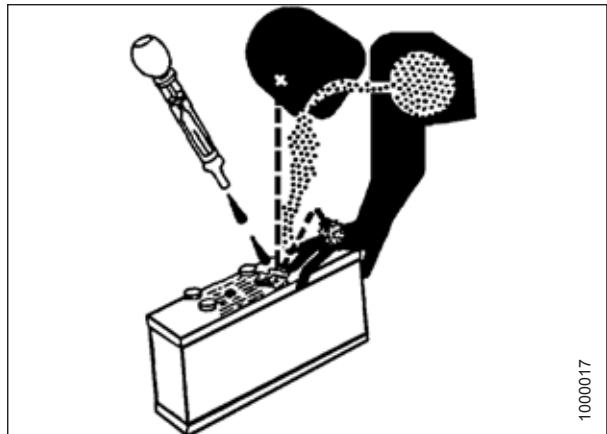

Figure 1.18: Safety around Batteries

1.8 Welding Precautions

High currents and voltage spikes associated with welding can cause damage to electronic components. Before welding on any part of the windrower or an attached header, disconnect all electronic module harness connections as well as battery cables. For instructions, refer to your Dealer for proper procedures.

1.9 Engine Safety

WARNING

Do NOT use aerosol starting aids such as ether. Such use could result in an explosion and personal injury.

CAUTION

- On initial start-up of a new, serviced, or repaired engine, always be ready to stop the engine to prevent an overspeed. Do this by shutting off the air and/or fuel supply to the engine.
- Do NOT bypass or disable automatic shutoff circuits. The circuits help prevent personal injury, and prevent engine damage. Contact your Dealer for repairs and adjustments.
- Inspect the engine for potential hazards.
- Before starting the engine, ensure no one is on, underneath, or close to the engine. Ensure that people clear the area.
- All protective guards and covers must be installed if the engine must be started to perform service procedures.
- To help prevent an accident, work around rotating parts carefully.
- If a warning tag is attached to the engine start switch or controls, do NOT start engine or move controls. Consult whoever attached the warning tag before starting the engine.
- Start engine from operator's station. Follow procedure in the Starting Engine section of the operator's manual. Knowing the correct procedure will help prevent major damage to engine components and prevent personal injury.
- To ensure that the jacket water heater (if equipped) and/or lubricant oil heater (if equipped) is working correctly, check the water temperature gauge and/or oil temperature gauge during heater operation.
- Engine exhaust contains products of combustion, which can be harmful to your health. Always start and operate the engine in a well-ventilated area. If the engine is started in an enclosed area, vent exhaust to the outside.
- Engine exhaust gases become very hot during operation and can burn people and common materials. Stay clear of the rear of machine and avoid exhaust gases when engine is running.

NOTE:

The engine may not be equipped with a device for cold starting. If the engine will be operated in very cold conditions, then an additional cold-starting aid may be required.

1.9.1 High-Pressure Rail

WARNING

- Contact with high-pressure fuel may cause fluid penetration and burn hazards. High-pressure fuel spray may cause a fire hazard. Failure to follow these instructions may cause personal injury or death.
- Before disconnecting fuel lines or any other components under high-pressure between the fuel pump and high-pressure common rail fuel system, confirm that the fuel pressure is relieved.

1.9.2 Engine Electronics

WARNING

Tampering with electronic system installation or original equipment manufacturer (OEM) wiring installation can be dangerous and could result in personal injury or death and/or engine damage.

WARNING

Electrical Shock Hazard. The electronic unit injectors use DC voltage. The engine control module (ECM) sends this voltage to the electronic unit injectors. Do NOT come in contact with the harness connector for the electronic unit injectors while engine is operating. Failure to follow this instruction could result in personal injury or death.

This engine has a comprehensive, programmable engine monitoring system. The ECM has the ability to monitor engine operating conditions. If conditions exceed the allowable range, the ECM will initiate immediate action.

The engine monitoring system can initiate the following actions:

- Warning
- Derate
- Shut down

Abnormalities in the following monitored conditions can limit engine speed and/or engine power:

- Engine coolant temperature
- Engine oil pressure
- Engine speed
- Intake manifold air temperature

The engine monitoring package can vary for different engine models and different engine applications. However, monitoring system and engine monitoring control will be similar for all engines. Together, two controls provide engine monitoring function for specific engine application.

1.10 Safety Signs

- Keep safety signs clean and legible at all times.
- Replace safety signs that are missing or illegible.
- If original part on which a safety sign was installed is replaced, be sure the repair part displays the current safety sign.
- Replacement safety signs are available from your MacDon Dealer Parts Department.

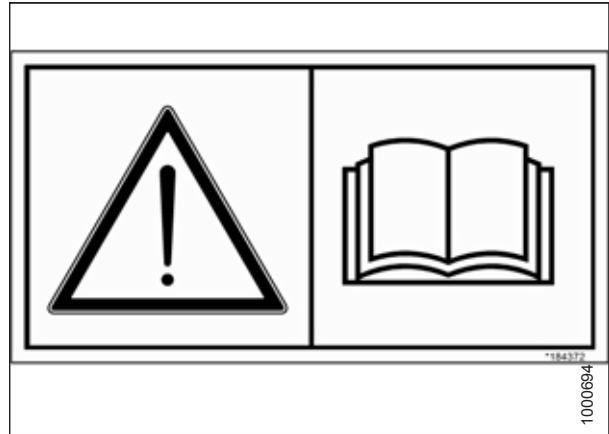

Figure 1.19: Operator's Manual Decal

1.10.1 Installing Safety Decals

1. Clean and dry installation area.
2. Decide on exact location before you remove decal backing paper.
3. Remove smaller portion of split backing paper.
4. Place decal in position and slowly peel back remaining paper, smoothing decal as it is applied.
5. Prick small air pockets with a pin and smooth out.

1.11 Safety Sign Locations

Figure 1.20: Safety Sign Locations (Left Cab-Forward Side)

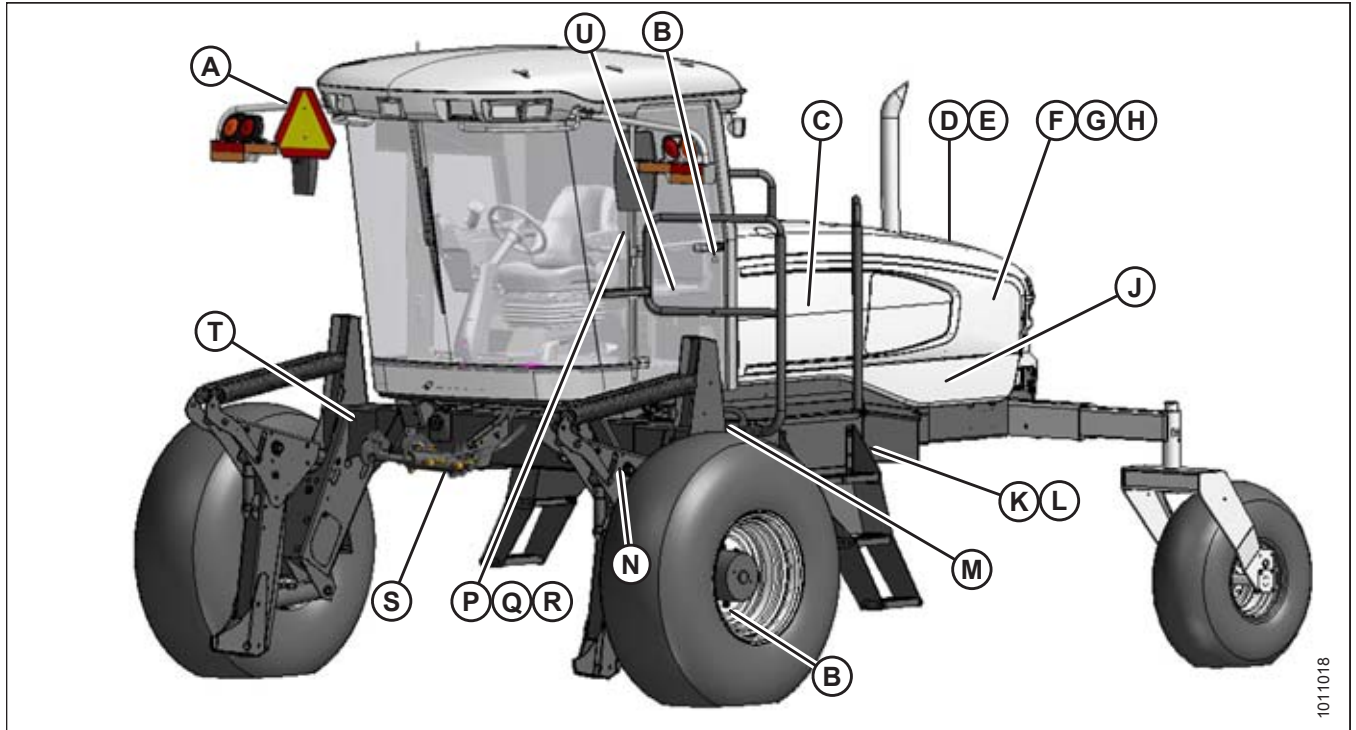

A - Hazard Sign (MD #135378)

D - Exhaust Cover (MD #166450)

G - Fan Shroud (Middle) (MD #166451)

K - Platform (Left of Step) (MD #166425)

N - Lift Linkage (MD #306179/306181)

R - Inner Post (MD #166463)

U - Trainer's Seat (MD #167502)

B - Cab Door and Rim (MD #166454)

E - Close to Radiator Cap (MD #166461)

H - Fan Shroud (Bottom) (MD #166452)

L - Platform (Right of Step) (MD #166441)

P - Inner Post (MD #166457)

S - Neutral Interlock (MD #166425)

C - Oil Reservoir under Hood (MD #166466)

F - Fan Shroud (Top) (MD #166450)

J - Frame Opening (MD #166233)

M - Frame at Multifunction Manifold (MD #166466)

Q - Inner Post (MD #166234)

T - Frame (MD #166425)

SAFETY

Figure 1.21: Safety Signs (Left Cab-Forward Side)

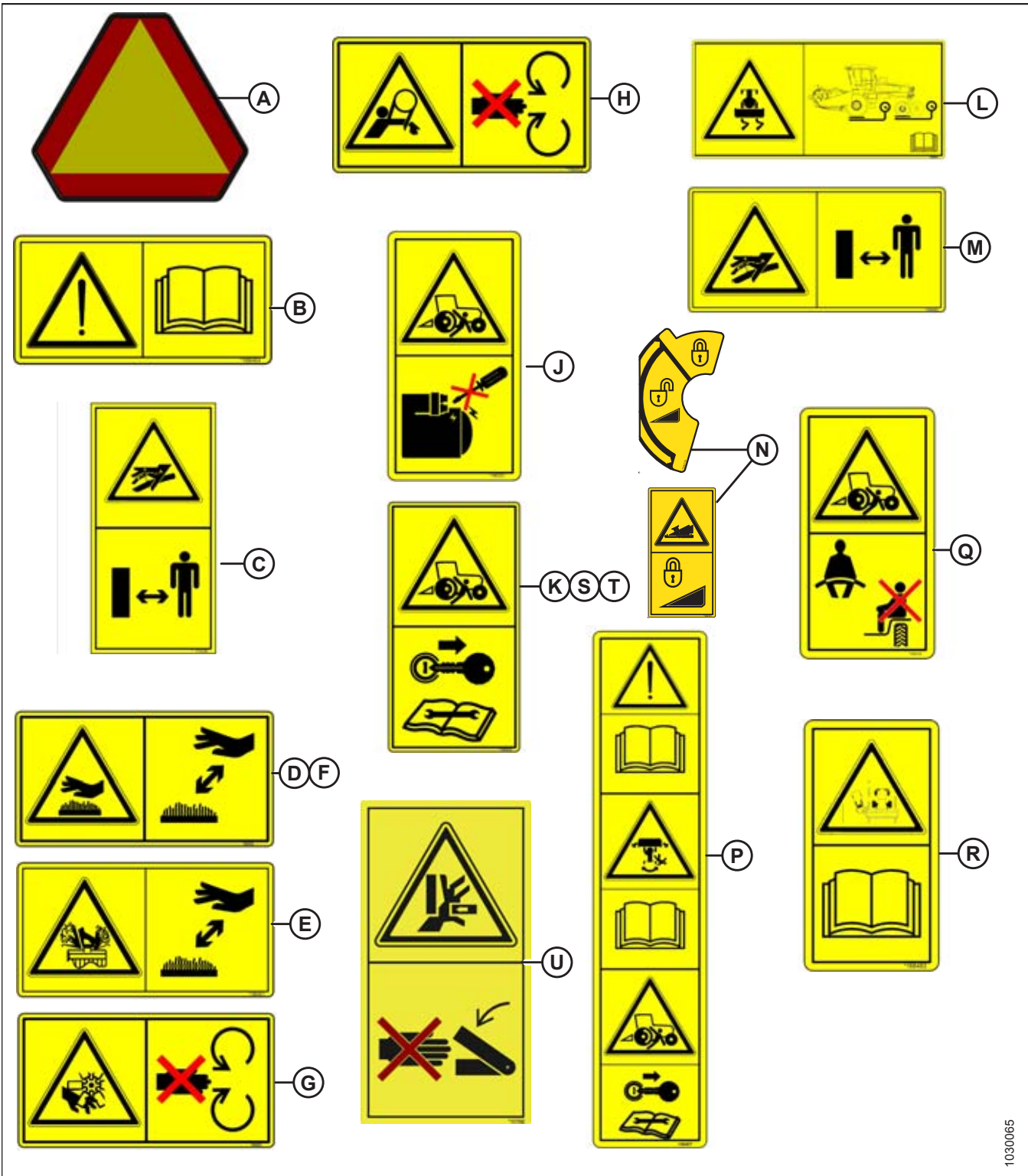

1030065

SAFETY

Figure 1.22: Safety Sign Locations (Right Cab-Forward Side)

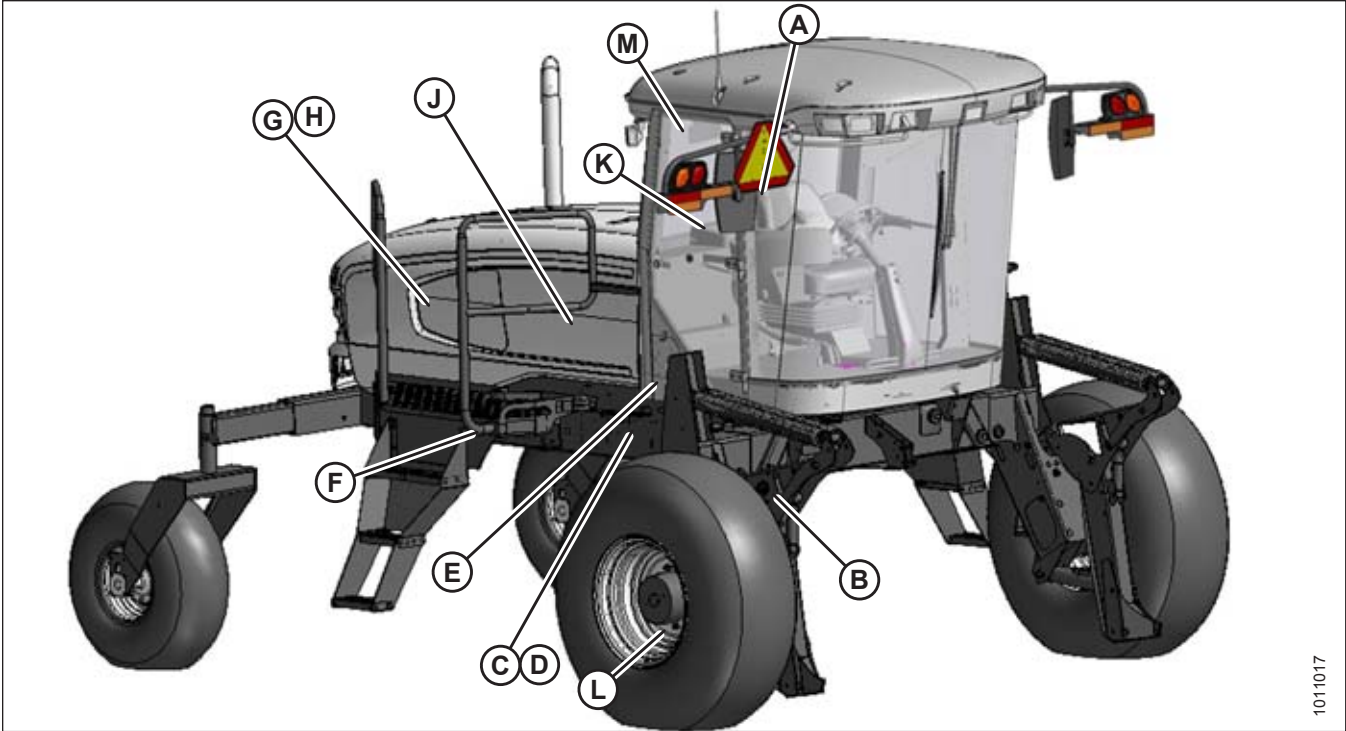

1011017

- | | | |
|--------------------------------------|--------------------------------------|--------------------------------------|
| A - Hazard Sign on Seat (MD #115148) | B - Lift Linkage (MD #306180/306181) | C - Frame (MD #166455) |
| D - Frame (MD #166456) | E - Cab Frame (MD #184372) | F - Platform (MD #166425) |
| G - Shroud (MD #166451) | H - Shroud (MD #166452) | J - Hydraulic Reservoir (MD #174436) |
| K - Wiper Cover (MD #166465) | L - Rim (MD #166454) | M - Window (MD #167504) |

SAFETY

Figure 1.23: Safety Signs (Right Cab-Forward Side)

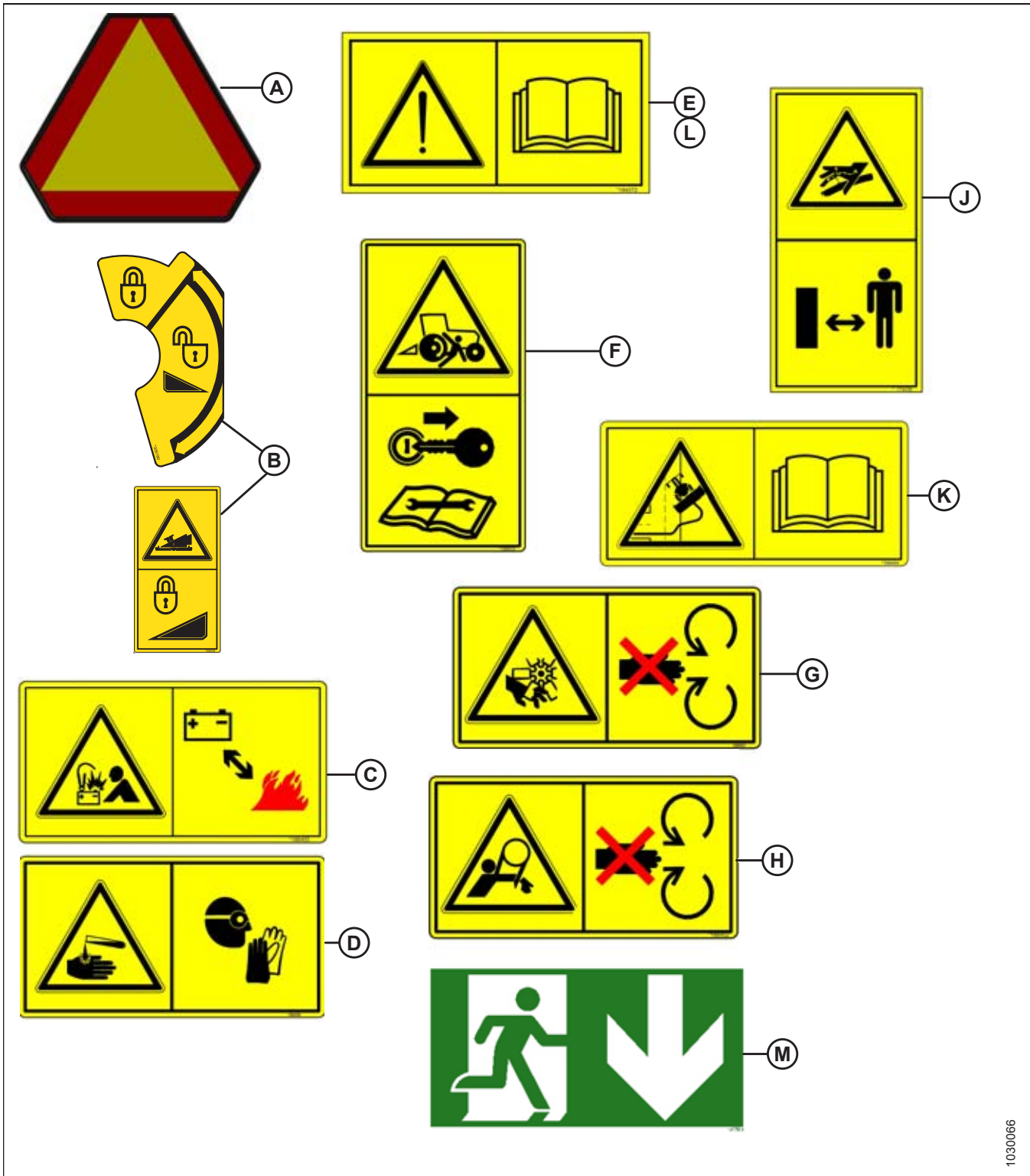

1030066

1.12 Understanding Safety Signs

MD #166233

Run-over hazard

DANGER

- Do **NOT** start engine by shorting across starter or starter relay terminals. Machine will start with drive engaged and move if starting circuitry is bypassed.
- Start engine only from operator's seat. Do **NOT** try to start engine with someone under or near machine.



Figure 1.24: MD #166233

MD #166234

Run-over hazard

WARNING

- The training seat is provided for an experienced Operator of the machine when a new Operator is being trained.
- The training seat is **NOT** intended as a passenger seat or for use by children.
- Use the seat belt whenever operating the machine or riding as a trainer.
- Keep all other riders off the machine.



Figure 1.25: MD #166234

MD #166425

Run-over hazard

WARNING

- Remove the key from the ignition.
- Read the windrower and header manuals for inspection and maintenance instructions.

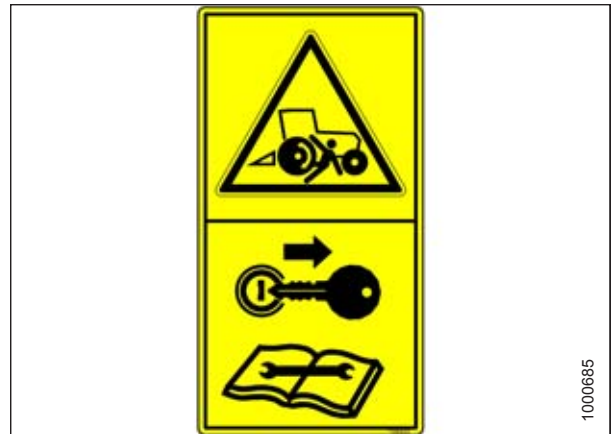

Figure 1.26: MD #166425

SAFETY

MD #166441

Loss of control hazard

CAUTION

- To prevent machine damage and/or loss of control, it is essential that the machine be equipped such that weights are within the specified limits.

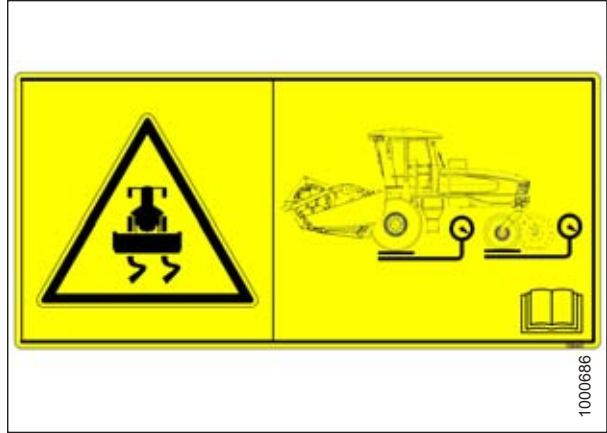

Figure 1.27: MD #166441

MD #166450

Hot surface hazard

WARNING

- To avoid injury, keep a safe distance from hot surface.

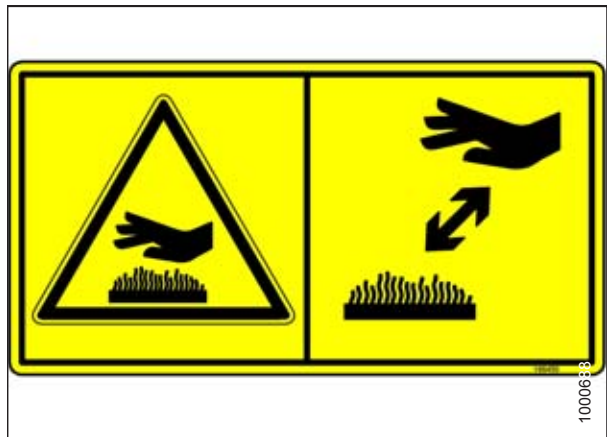

Figure 1.28: MD #166450

MD #166451

Rotating fan hazard

WARNING

- To avoid injury, stop the engine and remove the key before opening engine hood.

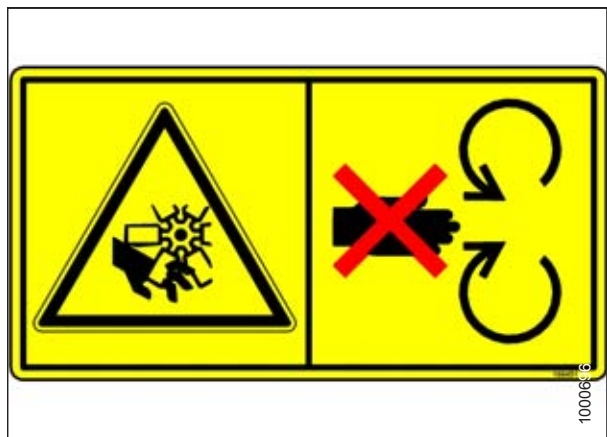

Figure 1.29: MD #166451

SAFETY

MD #166454

General hazard pertaining to machine operation and servicing

CAUTION

- Read the operator's manual and follow all safety instructions.
- Do **NOT** allow untrained persons to operate the machine.
- Review safety instructions with all Operators every year.
- Ensure that all safety signs are installed and legible.
- Make certain everyone is clear of machine before starting engine and during operation.
- Keep riders off the machine.
- Keep all shields in place and stay clear of moving parts.
- Disengage header drive, put transmission in Neutral, and wait for all movement to stop before leaving operator's position.
- Stop the engine and remove the key from the ignition before servicing, adjusting, lubricating, cleaning, or unplugging machine.
- Engage locks to prevent lowering of header or reel before servicing in the raised position.
- Use slow moving vehicle emblem and flashing warning lights when operating on roadways unless prohibited by law.



Figure 1.30: MD #166454

MD #166455

Explosion hazard

WARNING

- Prevent serious bodily injury caused by explosive battery gases.
- Keep sparks and flames away from the battery.
- For instructions, refer to operator's manual for battery boosting and charging procedures.



Figure 1.31: MD #166455

MD #166456

Battery acid hazard

WARNING

- Corrosive and poisonous battery acid. Acid can severely burn your body and clothing.



Figure 1.32: MD #166456

SAFETY

MD #166457

General hazard pertaining to machine operation and servicing

CAUTION

To avoid injury or death from improper or unsafe machine operation:

- Read the operator's manual and follow all safety instructions.
- Do **NOT** allow untrained persons to operate the machine.
- Review safety instructions with all Operators every year.
- Ensure that all safety signs are installed and legible.
- Make certain everyone is clear of machine before starting engine and during operation.
- Keep riders off the machine.
- Keep all shields in place and stay clear of moving parts.
- Disengage header drive, put transmission in Neutral and wait for all movement to stop before leaving operator's position.
- Stop the engine and remove the key from the ignition before servicing, adjusting, lubricating, cleaning, or unplugging machine.
- Engage locks to prevent lowering of header or reel before servicing in the raised position.
- Use slow moving vehicle emblem and flashing warning lights when operating on roadways unless prohibited by law.

Run-over hazard

WARNING

- Machine will move if steering wheel is turned while engine is running.
- Steering response is opposite to what is normally expected when backing up. Turn bottom of steering wheel in direction you want to go.
- Always move ground speed lever to slow end of range before shifting high-low speed control.
- Stop the engine and remove the key from the ignition before servicing, adjusting, lubricating, cleaning, or unplugging the machine.

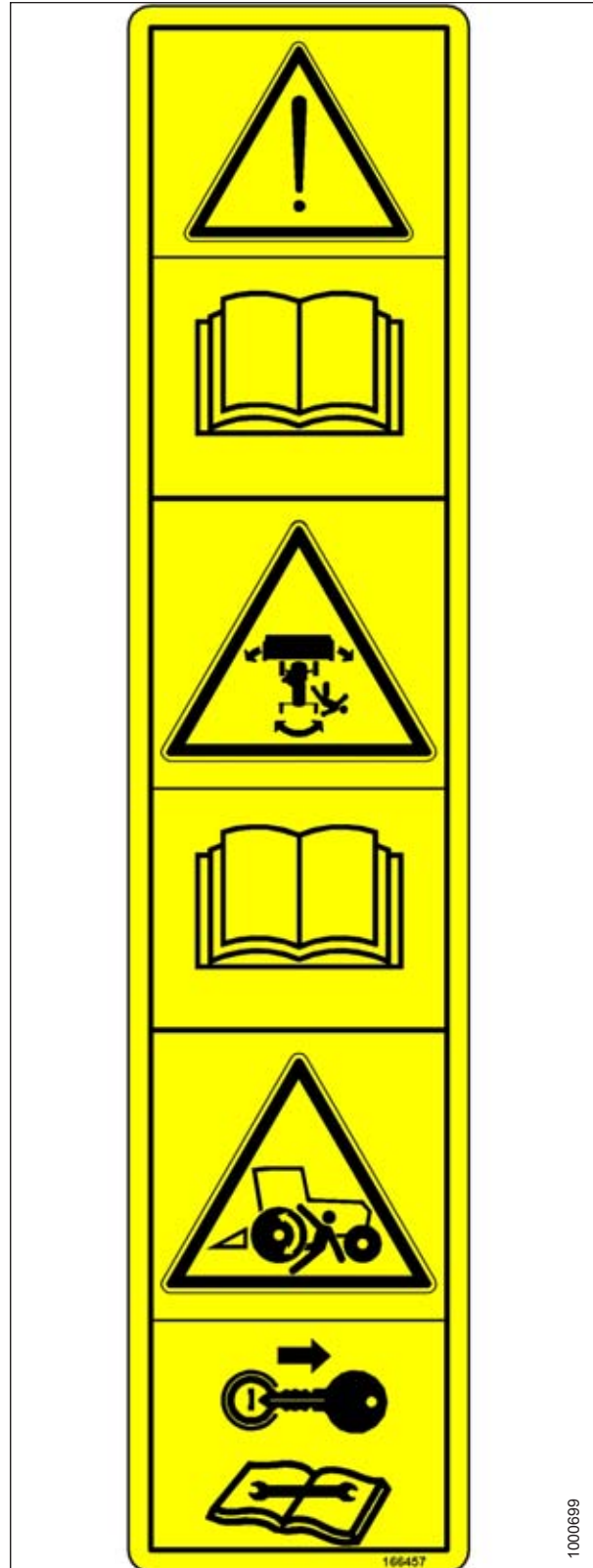

Figure 1.33: MD #166457

SAFETY

MD #166461

Hot fluid under pressure hazard

CAUTION

- Coolant is under pressure and may be hot. Never remove radiator cap when engine is hot.



Figure 1.34: MD #166461

MD #166463

Collision hazard in transport

WARNING

- Collision between windrower and other vehicles may result in injury or death.

When driving windrower on public roadways:

- Obey all highway traffic regulations in your area. Use pilot vehicles front and rear of windrower if required by law.
- Use slow moving vehicle emblem and flashing warning lights unless prohibited by law.
- If width of attached header impedes other vehicle traffic, remove header and install MacDon approved weight box. For instructions, refer to the operator's manual for safe procedure to tow header.



Figure 1.35: MD #166463

MD #166465

Loss of control hazard

WARNING

To avoid serious injury or death from loss of control:

- Do **NOT** make abrupt changes in steering direction.
- Anticipate turns by slowing down well in advance.
- Do **NOT** rapidly accelerate or decelerate while turning.

When travelling on steep slopes:

- Reduce speed and lower header.
- Move ground speed lever to slow end of range.
- Shift high-low speed control to low range.

With header removed, steering control is reduced if weight is not added to drive wheels. If you must drive the windrower without header or MacDon weight system:

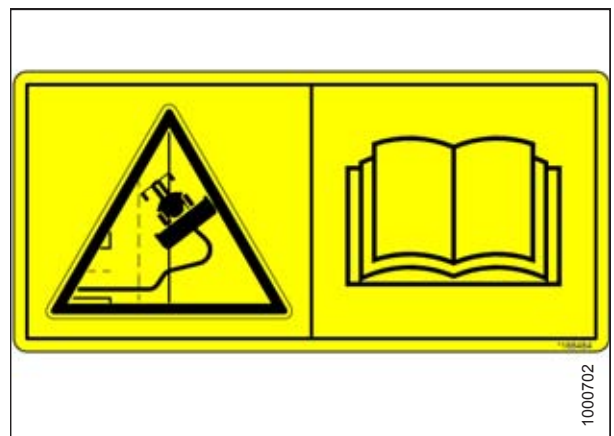

Figure 1.36: MD #166465

SAFETY

- Operate in low-speed range.
- Avoid slopes.
- Do **NOT** tow a header. **If control of machine is lost, immediately pull ground speed lever to neutral.**

MD #166466

High-pressure oil hazard

WARNING

- Do **NOT** go near leaks.
- High-pressure oil easily punctures skin, causing serious injury, gangrene, or death.
- If injured, seek emergency medical help. Immediate surgery is required to remove oil.
- Do **NOT** use finger or skin to check for leaks.
- Lower load or relieve hydraulic pressure before loosening fittings.



Figure 1.37: MD #166466

MD #166843

Steering control

WARNING

To avoid serious injury or death from loss of control:

- Do **NOT** make abrupt changes in steering direction.
- Anticipate turns by slowing down well in advance.
- Do **NOT** rapidly accelerate or decelerate while turning.

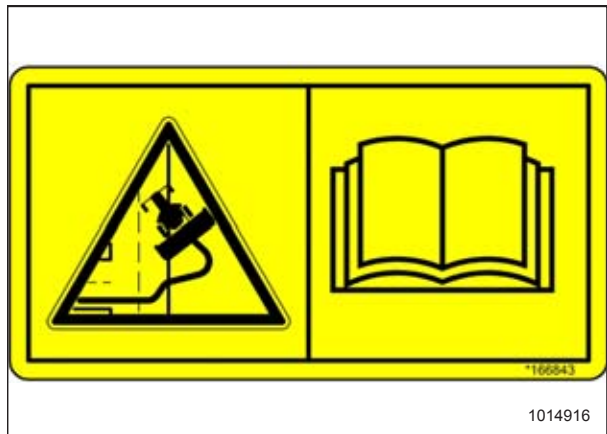

Figure 1.38: MD #166843

MD #167502

Pinch point hazard

WARNING

- To avoid injury, be cautious when opening/closing the training seat to avoid getting pinched.
- Failure to comply could result in death or serious injury.



Figure 1.39: MD #167502

SAFETY

MD #167504

Emergency exit

ATTENTION

- To exit the machine via the secondary door, follow the arrow on the running man sign.



Figure 1.40: MD #167504

MD #174436

High-pressure oil hazard

WARNING

- Do **NOT** go near leaks.
- High-pressure oil easily punctures skin, causing serious injury, gangrene, or death.
- If injured, seek emergency medical help. Immediate surgery is required to remove oil.
- Do **NOT** use finger or skin to check for leaks.
- Lower load or relieve hydraulic pressure before loosening fittings.



Figure 1.41: MD #174436

MD #190546

Slippery surface

WARNING

- Do **NOT** use this area as a step or platform.
- Failure to comply could result in serious injury or death.



Figure 1.42: MD #190546

SAFETY

MD #306179/306181

Header crushing hazard

DANGER

- To avoid injury or death from fall of raised header, fully raise header, stop engine, remove key, and engage safety props before going under header.

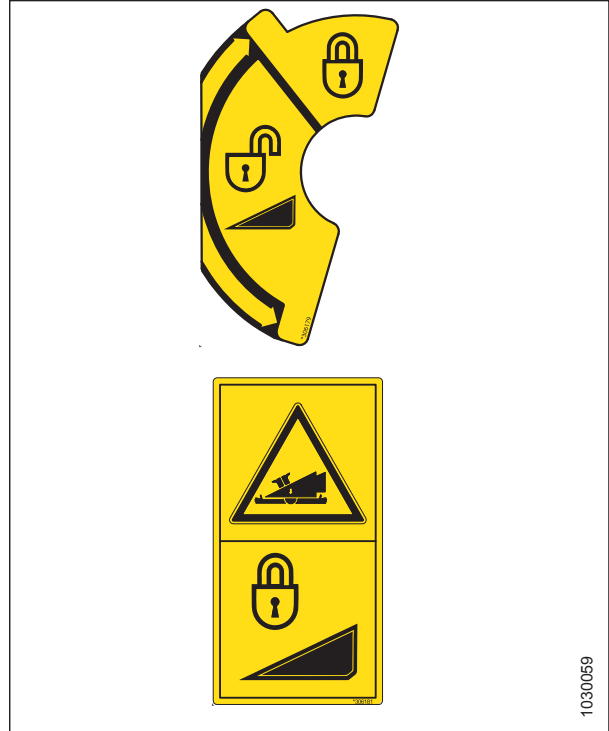

Figure 1.43: MD #306179/306181

MD #306180/306181

Header crushing hazard

DANGER

- To avoid injury or death from fall of raised header, fully raise header, stop engine, remove key, and engage safety props before going under header.

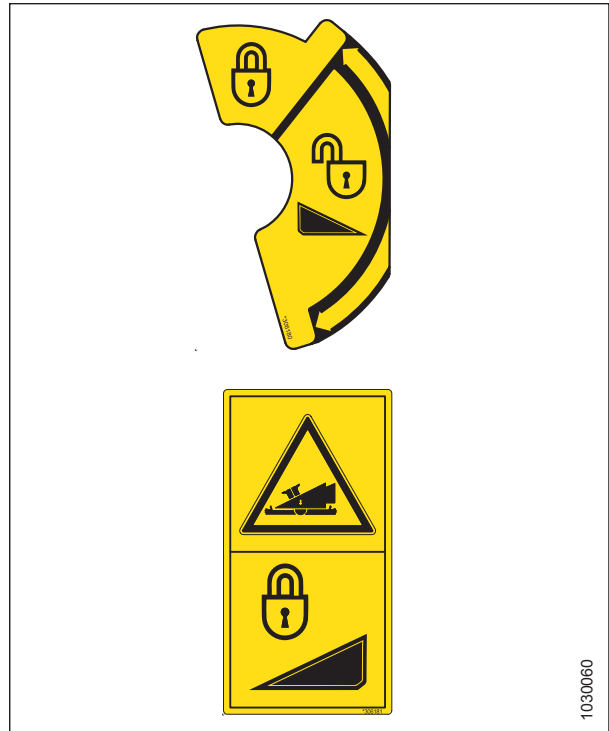

Figure 1.44: MD #306180/306181

Chapter 2: Product Overview

2.1 Definitions

The following terms and acronyms may be used in this manual:

Term	Definition
A Series header	MacDon A30D and A40D auger headers
API	American Petroleum Institute
ASTM	American Society of Testing and Materials
Bolt	A headed and externally threaded fastener that is designed to be paired with a nut
Cab-forward	Windrower operation with Operator and cab facing in direction of travel
CDM	Cab display module on a windrower
Center-link	A hydraulic cylinder or manually adjustable turnbuckle type link between header and machine used to change header angle
CGVW	Combined gross vehicle weight
D Series Header	MacDon D50, D60, and D65 rigid draper headers
D1 SP Series Header	MacDon D115, D120, D125, D130, D135, and D140 SP rigid draper headers for M Series Windrower
DDD	Double-draper drive
DK	Double knife
DKD	Double-knife drive
ECM	Engine control module
Engine-forward	Windrower operation with Operator and engine facing in direction of travel
FFFT	Flats from finger tight
Finger tight	Finger tight is a reference position where sealing surfaces or components are making contact with each other, and fitting has been tightened to a point where fitting is no longer loose
GSL	Ground speed lever
GSS	Grass Seed
GVW	Gross vehicle weight
Hard joint	A joint made with use of a fastener where joining materials are highly incompressible
Header	A machine that cuts and lays crop into a windrow and is attached to a windrower
Hex key	A tool of hexagonal cross-section used to drive bolts and screws that have a hexagonal socket in head (internal-wrenching hexagon drive); also known as an Allen key and various other synonyms
HDS	Hydraulic deck shift
hp	Horsepower
ISC	Intermediate Speed Control
JIC	Joint Industrial Council: A standards body that developed standard sizing and shape for original 37° flared fitting

PRODUCT OVERVIEW

Term	Definition
Knife	A cutting device which uses a reciprocating cutter (also called a sickle)
MDS	Mechanical deck shift
n/a	Not applicable
N-DETENT	The slot opposite the NEUTRAL position of M Series SP Windrowers on operator's console
NPT	National Pipe Thread: A style of fitting used for low-pressure port openings. Threads on NPT fittings are uniquely tapered for an interference fit
Nut	An internally threaded fastener that is designed to be paired with a bolt
ORB	O-ring boss: A style of fitting commonly used in port openings on manifolds, pumps, and motors
ORFS	O-ring face seal: A style of fitting commonly used for connecting hoses and tubes. This style of fitting is also commonly called ORS, which stands for O-ring seal
R Series	MacDon R80 and R85 Rotary Disc Headers for windrowers
R1 SP Series	MacDon R113 and R116 Series Rotary Disc Headers for windrowers
RoHS (Reduction of Hazardous Substances)	A directive by the European Union to restrict use of certain hazardous substances (such as hexavalent chromium used in some yellow zinc platings)
rpm	Revolutions per minute
SAE	Society of Automotive Engineers
Screw	A headed and externally threaded fastener that threads into preformed threads or forms its own thread into a mating part
SDD	Single-drapeer drive
Self-Propelled (SP) Windrower	Self-propelled machine consisting of a power unit with a header
SK	Single knife
SKD	Single-knife drive
Soft joint	A joint made with use of a fastener where joining materials are compressible or experience relaxation over a period of time
spm	Strokes per minute
Tension	Axial load placed on a bolt or screw, usually measured in Newtons (N) or pounds (lb.)
TFFT	Turns from finger tight
Torque	The product of a force X lever arm length, usually measured in Newton-meters (Nm) or foot-pounds (lb-ft)
Torque angle	A tightening procedure where fitting is assembled to a precondition (finger tight) and then nut is turned farther a number of degrees to achieve its final position
Torque-tension	The relationship between assembly torque applied to a piece of hardware and axial load it induces in bolt or screw
UCA	Upper cross auger
ULSD	Ultra-low sulphur diesel
Washer	A thin cylinder with a hole or slot located in the center that is to be used as a spacer, load distribution element, or locking mechanism

PRODUCT OVERVIEW

Term	Definition
WCM	Windrower control module
Windrower	Power unit for a header

PRODUCT OVERVIEW

2.2 Specifications

Engine		
Type		Cummins QSB-4.5L CM850 4 cylinder turbo diesel. B20 biodiesel approved.
Displacement		4.5 L (275 cu. in.)
Power	Rated	148 hp (110 kW) @ 2300 rpm
	Peak	156 hp (116 kW) @ 2000 rpm
Electrical System		
Recommended battery (2)		12 Volt, maximum dimension: 13.25 x 7.37 x 9.44 in (334 x 188 x 232 mm). group rating 29H or 31A. heavy duty / off road / vibration resistant.
Minimum CCA per battery (cold cranking amps)		650
Battery BCI group rating		29H or 31A
Alternator		130 amp
Egress lighting		Standard
Starter		Wet type
Working lights		11
Traction Drive		
Type		Hydrostatic, 3 speed electric shift
Speed	Field (cab-forward)	Low-range: 0–18 km/h (11 mph) Mid-range: 0–26 km/h (16 mph)
	Reverse (cab-forward)	9.6 km/h (6 mph)
	Transport (engine-forward)	High range: 0–37 km/h (23 mph)
Transmission	Type	2 Piston pumps: 1 per drive wheel.
	Displacement	44 cc (2.65 cu. in.)
	Flow	167 L/min (40 US gpm)
	Pressure	37,921 kPa (5500 psi)
Final drive	Type	Planetary gearbox
	Ratio	30.06 : 1
Wheel motor displacement	Low range	68 cc (4.15 cu. in.)
	Mid range	50 cc (3.01 cu. in.)
	High range	32 cc (1.93 cu. in.)

PRODUCT OVERVIEW

System Capacities		
Fuel tank		367 L (97 US gal)
Hydraulic reservoir		65 L (17.2 US gal)
Header Drive (Refer to Table 2.1, page 31).		
Header Lift/Tilt		
Type	Hydraulic double acting cylinders. Tilt - optional hydraulic positioning, Optional hydraulic center-link	
Function	Lift / tilt / float	
Header Float		
Primary adjustment	Manual, external, drawbolt with springs (1 per side). Two inner booster springs (1 per side)	
Fine adjustment	Hydraulic, in-cab switch	
Automatic	Hydraulic, 3 programmable settings for all headers (deck shift compensation on draper headers)	
Cab		
Type	Spring/shock suspension	
Dimensions	Width	1600 mm (63 in.)
	Depth	1735 mm (68.3 in.) (at top of window)
	Height	1640 mm (64.6 in.)
	Volume	3540 L (125 cu. ft.)
Seat	Driver	Adjustable air-ride suspension, seat belt
	Training	Folding, cab mounted, seat belt
Windshield wiper	Front	800 mm (31.5 in.) blade
	Rear	560 mm (22 in.) blade
Heater	7038 W (24,000 Btu/h)	
Air conditioning	8288 W (28,280 Btu/h)	
Electrical outlets	One live, two on ignition, one live/keyed	
Mirrors	One inside (transport), two outside (field)	
Radio	Two speakers and antenna factory installed. Radio is dealer-installed.	
System Monitoring		
Speeds	Ground (mph or km/h), engine (rpm), knife (spm), disc (rpm), reel (rpm or mph/km/h), conveyor (ref. no.)	
Header	Height, angle, float, header drive load gauge	

PRODUCT OVERVIEW

Tire Options (Refer to Table 2.2, page 33 for options).		
Frame And Structure		
Dimensions	Refer to 2.3 Windrower Dimensions, page 32	
Frame to ground (crop clearance)	1160 mm (45.7 in.)	
Weight	Base	4360 kg (9610 lb.) ¹
	Maximum GVW	9750 kg (21,500 lb.) ¹
	Maximum CGVW	10,480 kg (23,100 lb.) ¹
Header Compatibility		
Auger headers	A30D, A40D	All sizes
Draper headers	D50, D60, and D65 ²	Up to 10.7 m (35 ft.)
Draper headers	D60 and D65 40 ft. ²	12.2 m (40 ft.)
	D1 Series	Up to 12.2 m (40 ft.)
Rotary disc	R80 and R85	4.0 m (13 ft.) only ³
	R113 and R116	4.0 and 4.8 m (13 and 16 ft.)

NOTE:

Specifications and design are subject to change without notice or obligation to revise previously sold units.

Pump locations:

- Knife drive pump (A) (closest to engine)
- Reel/conveyor pump (B) (or M2 with disc)
- Inner gear pump (C) – Oil from the inner gear pump is normally routed directly to the cooler bypass valve and combines with the return flow from the first gear pump. From there the oil is cooled and moves through the high pressure filter and then into the supercharge valve manifold.
- Outboard gear pump (D) – The outboard gear pump supplies oil to the multifunction control manifold. The returned oil combines with the return flow from the inboard gear pump (C) at the cooler bypass and maintains standby pressure to operate brake disengage (either low- or high-speed range) and the neutral interlock cylinder.
- Traction drive double piston pump (E) – Engine end pump drives right wheel; outboard pump drives left wheel.

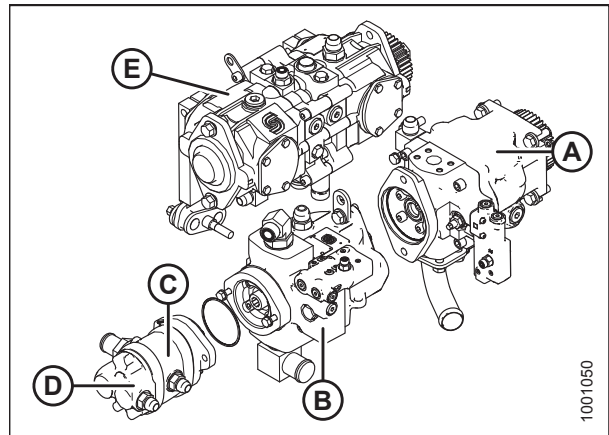

Figure 2.1: Pumps

1. Weights do not include options.
 2. Depending on header options
 3. Only 18.4 x 26 tires are compatible with the 4.0 m (13 ft.) R80 and R85.

PRODUCT OVERVIEW

Table 2.1 Hydraulic Pumps

Pump Type	Specifications	Controller Type	Function
Pump A – load sense pressure-compensated piston pump	Variable displacement: 0–45 cc (2.75 cu. in.) Flow = 0–102 L/min (27 gpm) at 27.56 MPa (4000 psi)	Electric over hydraulic Maximum flow rate determined by header ID	Knife drive or part of disc drive (option) M1 circuit
Pump B – load sense pressure-compensated piston pump	Variable displacement: 0–38 cc (2.32 cu. in.) Flow = 0–84 L/min (24 gpm) at 22.05 MPa (3200 psi)	Electric over hydraulic Maximum flow rate determined by header ID	Conveyor and reel drive or part of disc drive (option) M2 circuit
Pump C – gear pump	Displacement: 13.8 cc (0.84 cu. in.) Flow at full throttle 44 L/min (11.5 gpm) at 17.23 MPa (2500 psi)	Engine rpm	Supercharge flow and pressure for traction drive, brake release, and Neutral lock
Pump D – gear pump	Displacement: 13.8 cc (0.84 cu. in.) Flow at full throttle 44 L/min (11.5 gpm) at 17.23 MPa (2500 psi)	Engine rpm	Supercharge flow and pressure for traction drive, brake release, and Neutral lock

2.3 Windrower Dimensions

Figure 2.2: Windrower Dimensions – Cab-Forward

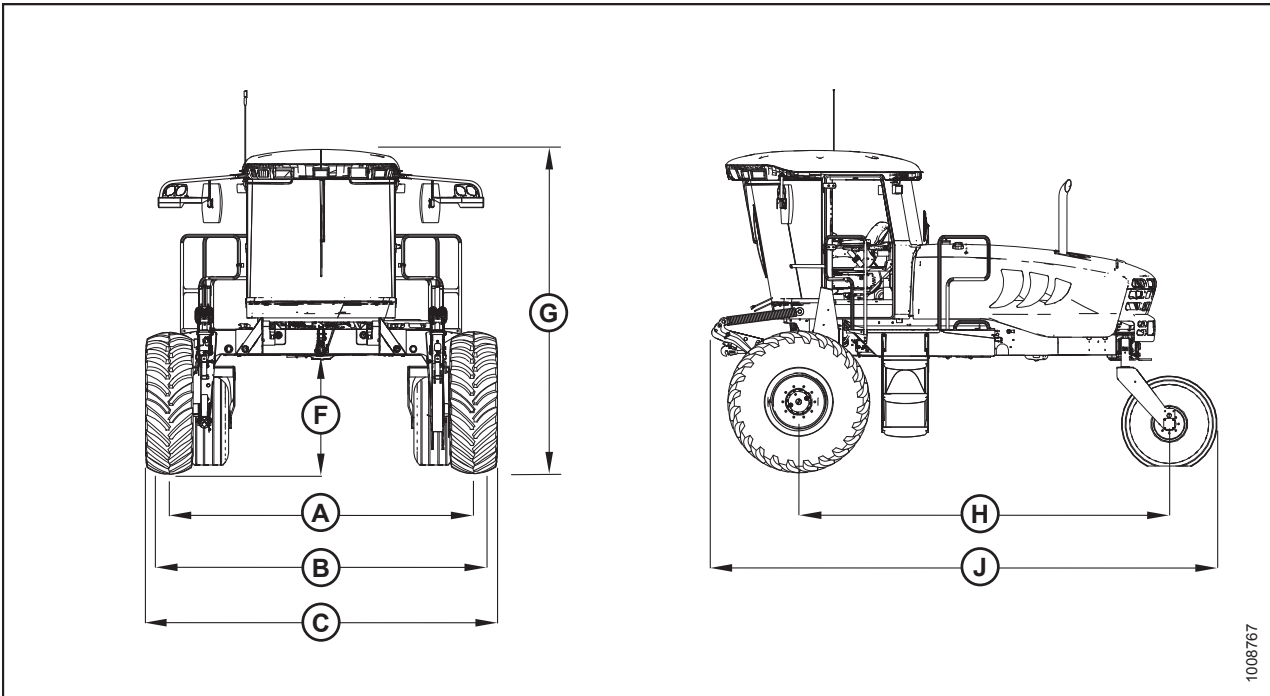

A - Drive Tire Tread
C - Drive Tires
G - 3378 mm (133 in.)
J - 5280 mm (207 7/8 in.)

B - Drive Tire Hubs
F - 1160 mm (45 3/4 in.)
H - 4022 mm (158 5/16 in.)

PRODUCT OVERVIEW

Table 2.2 Drive Tires

Tire Size	Wheel Position	Tread (A) mm (in.)	Hubs (B) mm (in.)	Tires (C) mm (in.)
18.4 x 26 bar and turf narrow track ⁴	Inner/outer (shipping)	3144 (123 3/4)	3571 (140 9/16)	3644 (143 7/16)
18.4 x 26 bar and turf narrow track ⁴	Outer/outer	3324 (130 7/8)	3751 (147 11/16)	3824 (150 5/8)
18.4 x 26 bar and turf narrow track ⁴	Inner/inner	2964 (116 11/16)	3391 (133 1/2)	3464 (136 3/8)
18.4 x 26 bar and turf wide track ⁴	Inner/outer (shipping)	3319 (130 11/16)	3571 (140 9/16)	3819 (150 3/8)
18.4 x 26 bar and turf wide track ⁴	Outer/outer	3499 (137 3/4)	3751 (147 11/16)	3999 (157 7/16)
18.4 x 26 bar and turf wide track ⁴	Inner/inner	3139 (123 9/16)	3391 (133 1/2)	3639 (143 1/4)
600/65R28 radial tire	Inner/outer (shipping)	3139 (123 9/16)	3571 (140 9/16)	3758 (147 15/16)
600/65R28 radial tire	Outer/outer	3319 (130 11/16)	3751 (147 11/16)	3938 (155 1/16)
600/65R28 radial tire	Inner/inner	2959 (116 1/2)	3391 (133 1/2)	3578 (140 7/8)
23.1-26 and 580/70R26 turf tires	Inner/outer (shipping)	3203 (126 1/8)	3571 (140 9/16)	3793 (149 5/16)
23.1-26 and 580/70R26 turf tires	Outer/outer	3383 (133 3/16)	3751 (147 11/16)	3973 (156 7/16)
23.1-26 and 580/70R26 turf tires	Inner/inner	3023 (119)	3391 (133 1/2)	3613 (142 1/4)

4. Only 18.4 x 26 tires are compatible with the 4.0 m (13 ft.) R80 and R85.

PRODUCT OVERVIEW

Figure 2.3: Windrower Dimensions – Engine-Forward

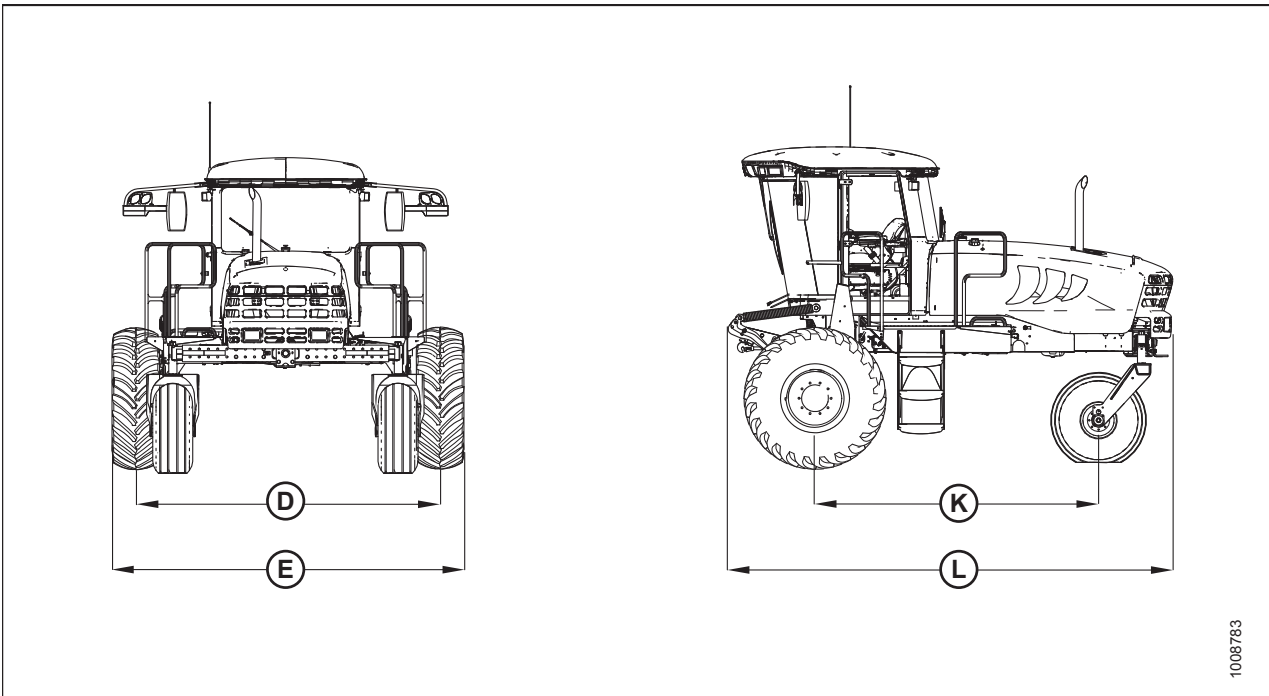

1008783

D - Caster Tire Tread
K - 3064 mm (120 9/16 in.)

E - Caster Tire Casters
L - 4747 mm (186 7/8 in.)

Table 2.3 Caster Tires

Tire Size	Wheel Position	Tread (D) mm (in.)	Castors (E) mm (in.)
7.5-16SL	Minimum	2448 (96 7/16)	3032 (118 15/16)
7.5-16SL	Maximum	3448 (135 11/16)	4032 (158 3/4)
10-16 formed caster	Minimum	2448 (96 7/16)	3032 (118 15/16)
10-16 formed caster	Maximum	3448 (135 11/16)	4032 (158 3/4)
10-16 forked caster	Minimum	2448 (96 7/16)	3014 (118 11/16)
10-16 forked caster	Maximum	3448 (135 11/16)	4014 (158)
16.5 x 16.1	Minimum	2448 (96 7/16)	3014 (118 11/16)
16.5 x 16.1	Maximum	3448 (135 11/16)	4014 (158)

2.4 Component Location

Figure 2.4: Front Cab-Forward View

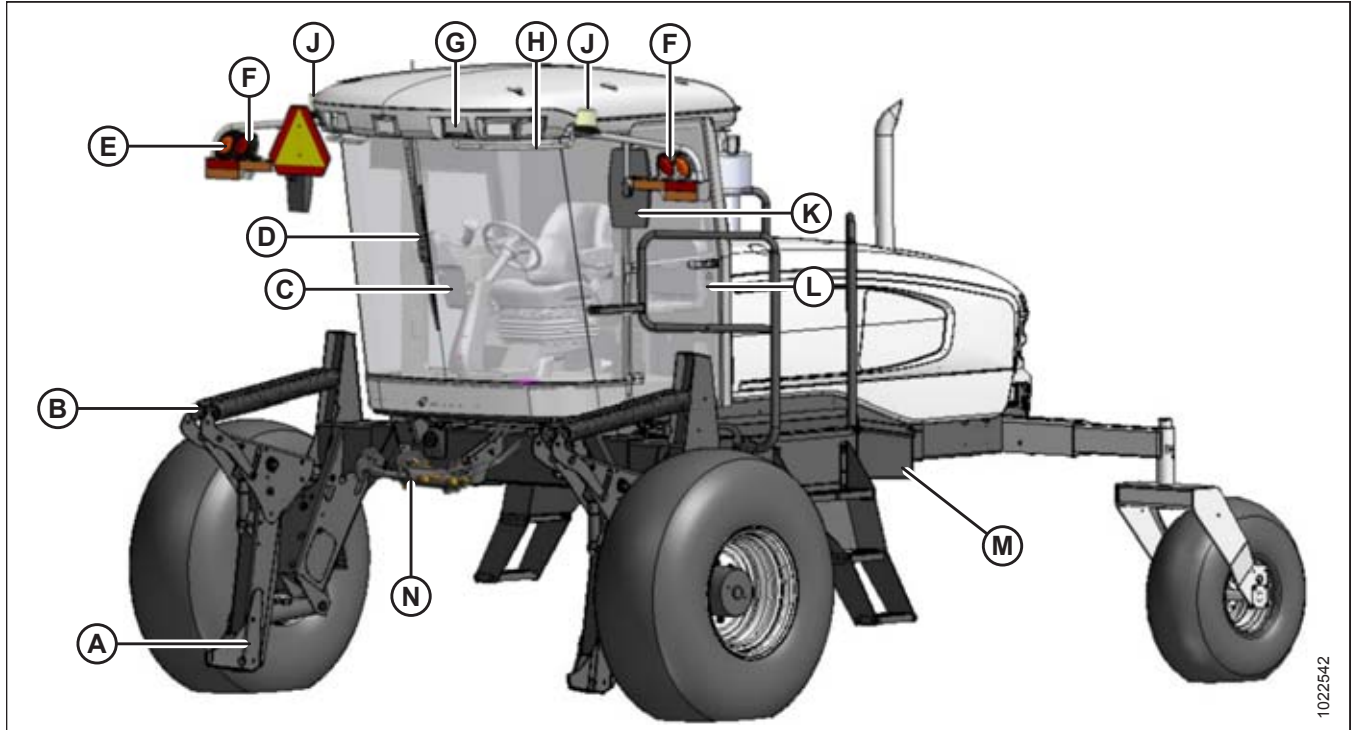

A - Header Lift Leg
D - Windshield Wiper
G - Field/Road Lights
K - Mirror
N - Center-Link

B - Header Float Springs
E - Turn Signal/Hazard Lights
H - Handholds
L - Door

C - Operator's Station
F - Taillight Engine-Forward
J - Beacon
M - Maintenance Platform

PRODUCT OVERVIEW

Figure 2.5: Front Cab-Forward View

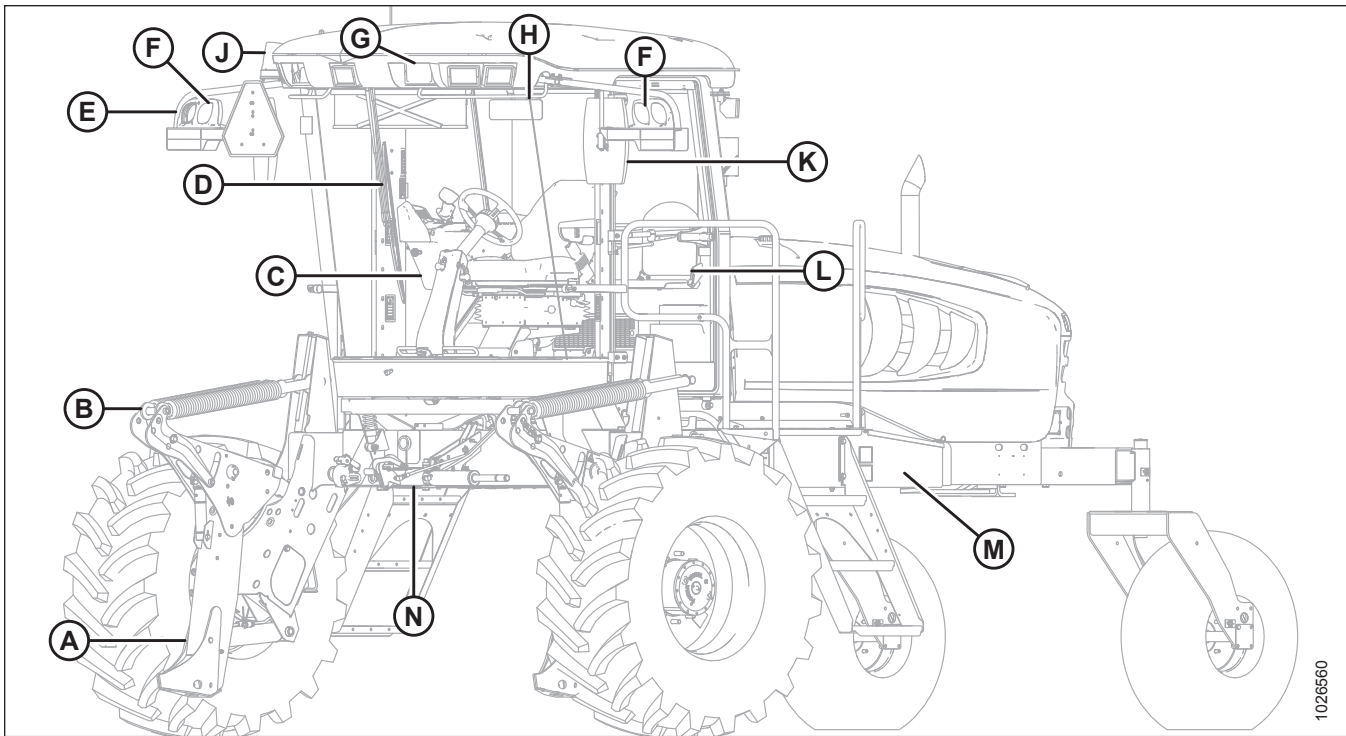

1026560

A - Header Lift Leg
D - Windshield Wiper
G - Field/Road Lights
K - Mirror
N - Center-Link

B - Header Float Springs
E - Turn Signal/Hazard Lights
H - Handholds
L - Door

C - Operator's Station
F - Tail Light Engine-Forward
J - Beacon
M - Maintenance Platform

PRODUCT OVERVIEW

Figure 2.6: Rear Cab-Forward View

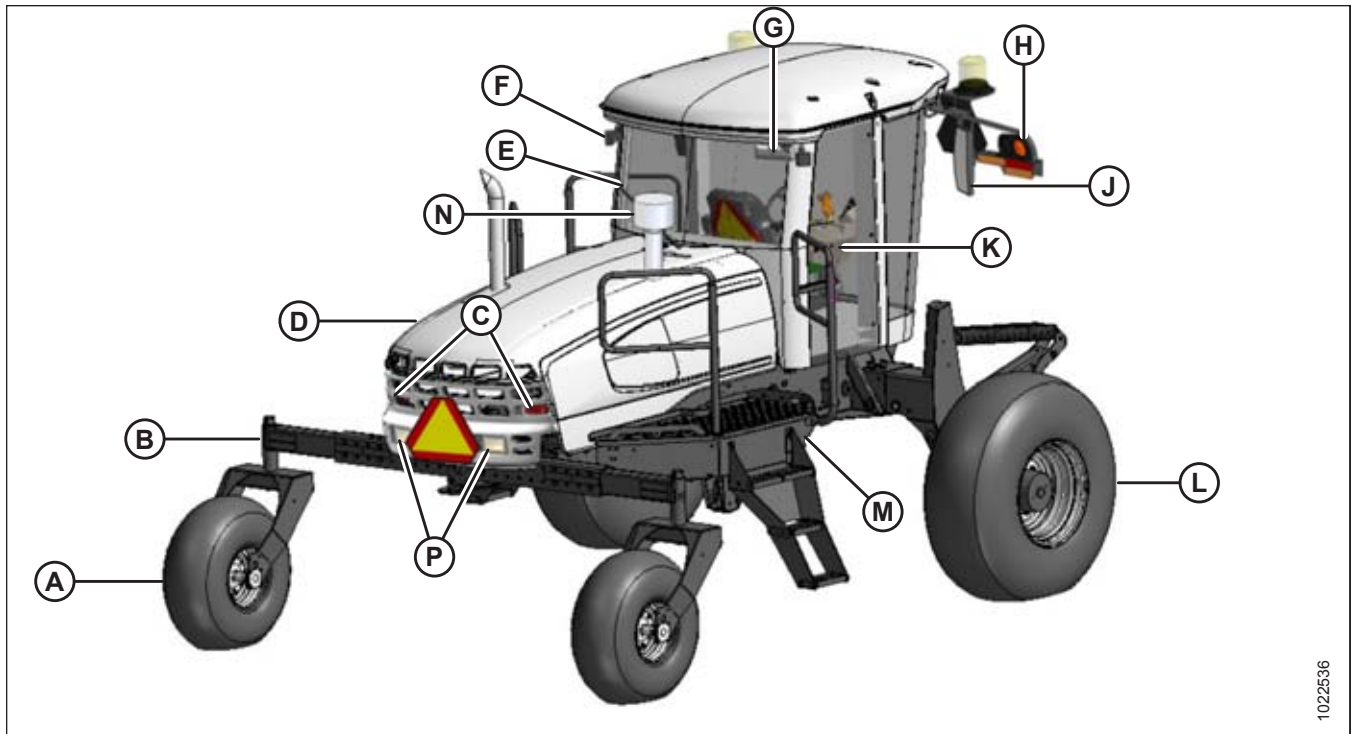

A - Caster Wheel
D - Engine Compartment Hood
G - Horn
K - Door
N - Engine Air Precleaner (Export)

B - Walking Beam
E - Windshield Wiper
H - Turn Signal/Hazard Lights
L - Drive Wheel
P - Headlights

C - Taillights - Cab-Forward (Option)
F - Field Lights
J - Mirror
M - Maintenance Platform

1022536

Chapter 3: Operator's Station

The operator's station is designed for operating the windrower in cab-forward mode (working mode) or in engine-forward mode (transport mode). The operator's station—which includes the seat, console, and steering column—pivots 180° to provide access to controls and gauges regardless of the direction of travel.

3.1 Operator Console

The console contains controls to operate the windrower, as well as amenities for the Operator. The console position is adjustable to suit each Operator.

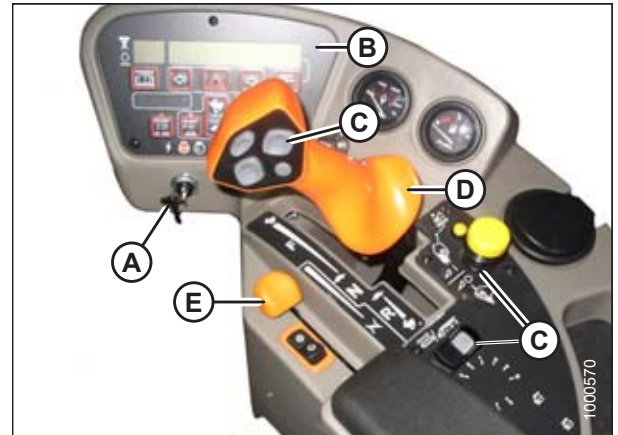

Figure 3.1: Operator Console

A - Ignition
B - Cab Display Module (CDM)
C - Header Controls
D - Ground Speed Lever (GSL)
E - Throttle

1. Adjusting fore-aft and height:
 - a. Pull lever (A) and slide console fore or aft to the desired position.
 - b. Release lever to lock console.

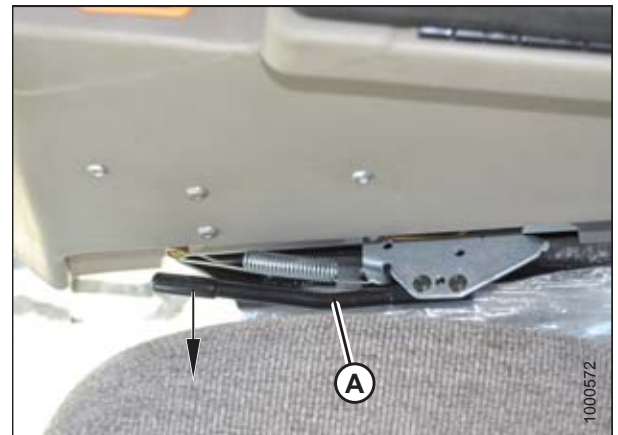

Figure 3.2: Console Fore-Aft

OPERATOR'S STATION

2. Adjusting only fore-aft:
 - a. Loosen nuts (A) under console.
 - b. Move console as required.
 - c. Tighten nuts (A).



Figure 3.3: Console Fore-Aft

3.2 Operator Presence System

The operator presence system is a safety feature designed to deactivate or alert selected systems when the Operator is not seated at the operator's station.

These systems include:

- Header drive
- Engine and transmission

3.2.1 Header Drive

- To engage the header drive, the Operator must be seated in the operator's seat.
- If the Operator leaves the seat, power to the header drive is maintained for 5 seconds, then the header shuts down automatically.
- To restart the header after an automatic shut down, move the HEADER DRIVE switch to the OFF position and then to the ON position.

3.2.2 Engine and Transmission

- If the HEADER DRIVE switch is engaged, the engine will not start.
- If the windrower is moving 8 km/h (5 mph) or slower and the Operator leaves the seat, the CDM will flash NO OPERATOR on the upper line and ENGINE SHUT DOWN 5...4...3...2...1...0 on the lower line accompanied by a steady tone. When the countdown reaches 0, the engine shuts down.
- If the windrower is moving 8 km/h (5 mph) or faster, and the Operator leaves the seat for more than 5 seconds, an alarm will sound and the lower display line will flash NO OPERATOR.
- If the operator's seat is in between cab-forward and engine-forward positions and the transmission is not locked in the NEUTRAL position, the engine shuts off. The lower display will flash LOCK SEAT BASE until the seat base is locked into position.

3.3 Operator's Seat Adjustments

The operator's seat has several adjustments. Refer to the following for the location and description of each adjustment.

3.3.1 Adjusting Fore-Aft Position

1. Pull lever (A) up to release.
2. Move seat forward or rearward.
3. Release lever (A).



Figure 3.4: Fore-Aft Position

3.3.2 Adjusting Seat Suspension and Height

Controls suspension stiffness and seat height.

INCREASE: Press upper switch (A).

DECREASE: Press lower switch (B).



Figure 3.5: Seat Suspension and Height

3.3.3 Adjusting Vertical Dampener

Controls suspension dampening.

INCREASE: Turn knob (A) counterclockwise.

DECREASE: Turn knob (A) clockwise.



Figure 3.6: Vertical Dampener

3.3.4 Adjusting Armrest

Raise armrest (A) for easier access to seat.

Lower armrest (A) after seat belt is buckled.



Figure 3.7: Armrest

3.3.5 Adjusting Fore-Aft Isolator Lock

Locks seat fore-aft isolator.

LOCK: Push lever (A) down.

UNLOCK: Pull lever (A) up.



Figure 3.8: Fore-Aft Isolator Lock

3.3.6 Adjusting Seat Tilt

1. Pull lever (A) up to release.
2. Position seat back as desired.
3. Release lever (A).



Figure 3.9: Seat Tilt

3.3.7 Adjusting Armrest Angle

INCREASE: Rotate knob (A) clockwise.

DECREASE: Rotate knob (A) counterclockwise.

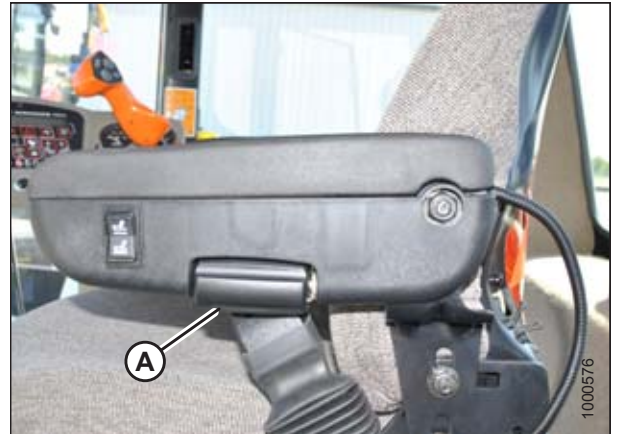

Figure 3.10: Armrest Angle

3.3.8 Adjusting Lumbar Support

Adjusts the stiffness of seat back.

INCREASE: Rotate knob (A) upward.

DECREASE: Rotate knob (A) downward.

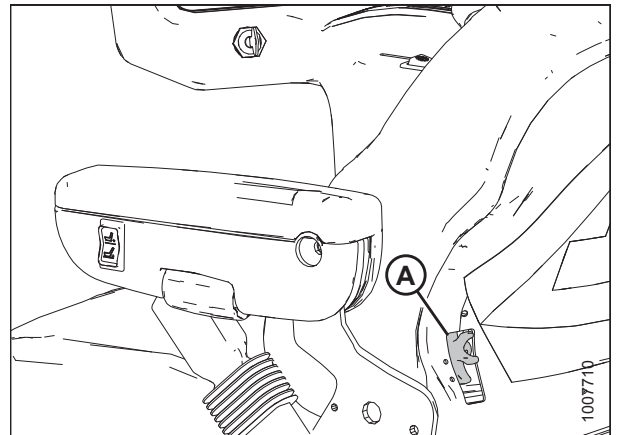

Figure 3.11: Lumbar Support

3.4 Training Seat

A wall-mounted, fold-up training seat complete with seat belt is provided.

WARNING

- The training seat is provided for use by an experienced machine Operator while training a new Operator.
- The training seat is NOT intended as a passenger seat or for use by children. Use the seat belt whenever operating the machine or riding as a Trainer.
- Keep all other riders off the machine.

For storage, lift seat (B) and secure with latch (A).

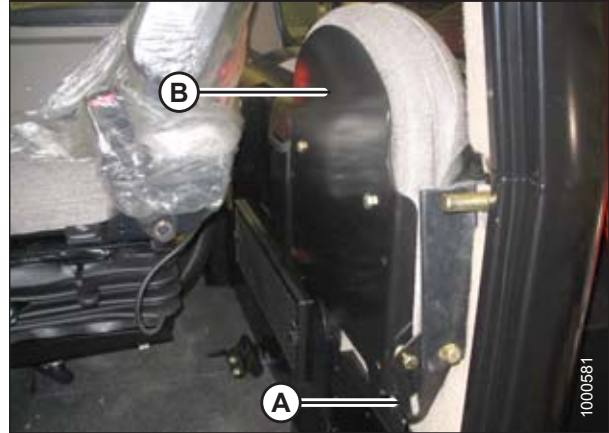

Figure 3.12: Training Seat in Storage Position

To lower seat, lift latch (A) and lower seat (B).



Figure 3.13: Training Seat

3.5 Using Seat Belts

The windrower is equipped with seat belts on the operator's and trainer's seats.

WARNING

Seat belts can help ensure your safety when properly used and maintained.

- Before starting the engine, fasten your seat belt, and ensure that the training seat occupant's seat belt is securely fastened.
- Never wear a seat belt loosely or with slack in the belt system. Never wear the belt in a twisted condition or pinched between the seat structural members.

To fasten seat belt:

1. Pull belt with metal eye (A) at right side completely across your body.
2. Push metal eye (A) into buckle (B) until it locks.
3. Adjust the position of the belt as low on your body as possible.

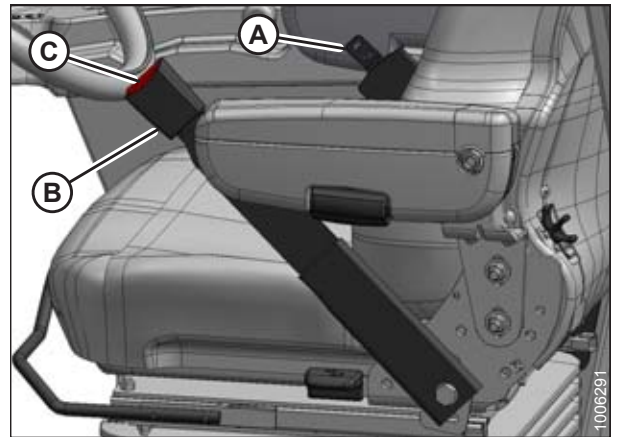

Figure 3.14: Seat Belt

To release seat belt:

4. Push red button (C) in the end of the buckle.
5. Separate buckle (B) and metal eye (A).

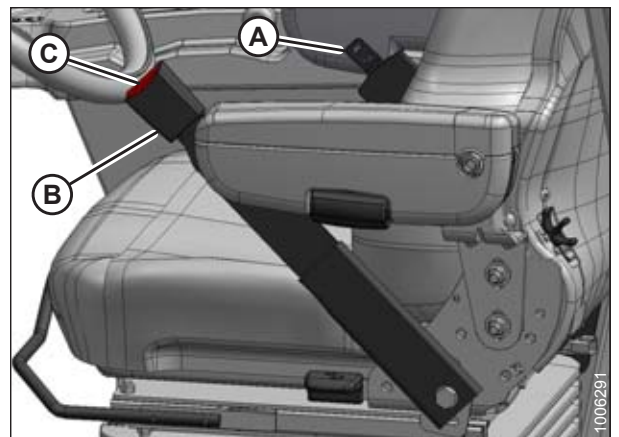

Figure 3.15: Seat Belt

3.6 Adjusting Steering Column

The steering column can be adjusted to suit each particular Operator and to make it easier to get in and out of the seat.

1. Hold onto the steering wheel, lift handle (A), and move the steering wheel up or down to desired position.
2. Release handle (A) to lock the steering wheel position.

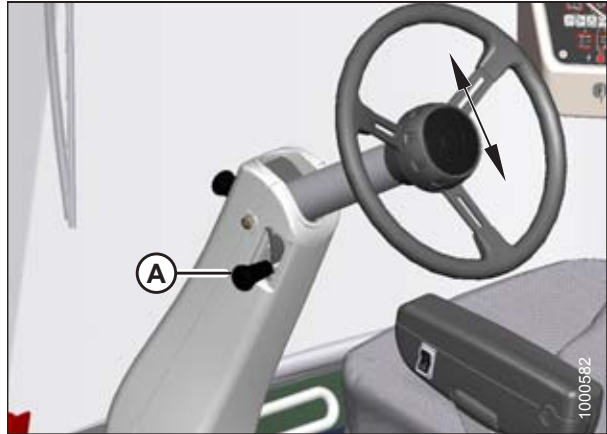

Figure 3.16: Steering Column

3.7 Exterior Lighting

The field/road (A), high/low beam (B), and beacon light (C) switches are located on a panel in the cab headliner. The hazard/turn signal switch is located on the cab display module (CDM).

The position of the operator's station (cab-forward mode or engine-forward mode) and the auto-road lighting feature automatically determines the lighting.

IMPORTANT:

Red and amber reflector tape is positioned so as to be visible in both engine-forward and cab-forward modes.

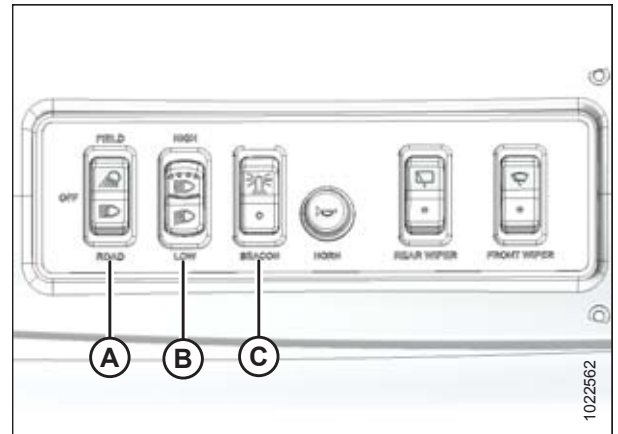

Figure 3.17: Headliner Console (except Russia)

- A - FIELD / OFF / ROAD
- B - HIGH / LOW
- C - BEACONS / OFF

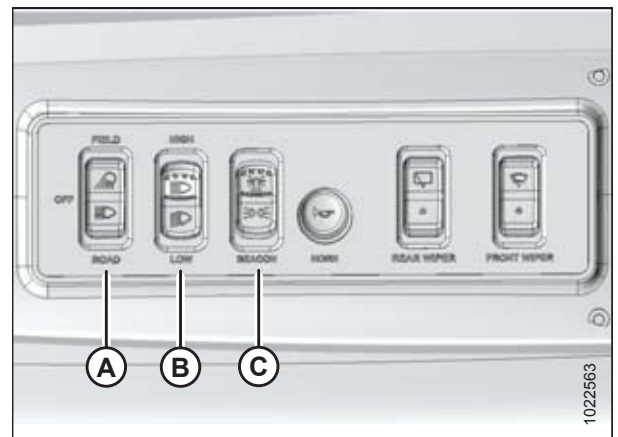

Figure 3.18: Headliner Console (Russia)

- A - FIELD / OFF / ROAD
- B - LOW / HIGH
- C - BEACON & CLEARANCE / OFF / CLEARANCE

3.7.1 Auto-Road Lighting

This system automatically activates a default set of lights for road travel when specific operating conditions are met.

This feature will activate road headlights, hazards, and beacons when the following conditions are met. They cannot be switched off manually as long as these conditions exist:

- Windrower is in cab- or engine-forward mode
- Engine is running
- Header is disengaged
- Transmission is in either mid or high range

3.7.2 Cab-Forward Lighting

This section explains the lighting defaults with the windrower in cab-forward mode.

Table 3.1 Cab-Forward Lighting

Switch Position ⇔⇔ Lights ↓	Auto Road Inactive		Auto Road Active ⁵	
	Field	Road	Field	Road
Field (A)	ON	OFF	OFF	OFF
Field (B)	ON	ON	ON	ON
Field (C)	ON with high or low beam	ON with high or low beam	ON with high or low beam	ON with high or low beam
Field (D)	ON	OFF	OFF	OFF
Tail (E)	OFF ⁶	OFF ⁶	OFF ⁶	OFF ⁶
Hazard/turn signals (F)	CDM switched	CDM switched	CDM switched	CDM switched
Tail (G)	OFF	ON	ON	ON
Header (H) (not shown)	OFF	OFF	OFF	OFF
Field (J)	ON with high or low beam	OFF	OFF	OFF
Beacons (K)	ON or OFF	ON or OFF	ON	ON

5. Engine running, transmission in mid-range, header disengaged

6. ON when three-position switch is in beacon position or clearance light position.

OPERATOR'S STATION

Figure 3.19: Cab-Forward Lighting

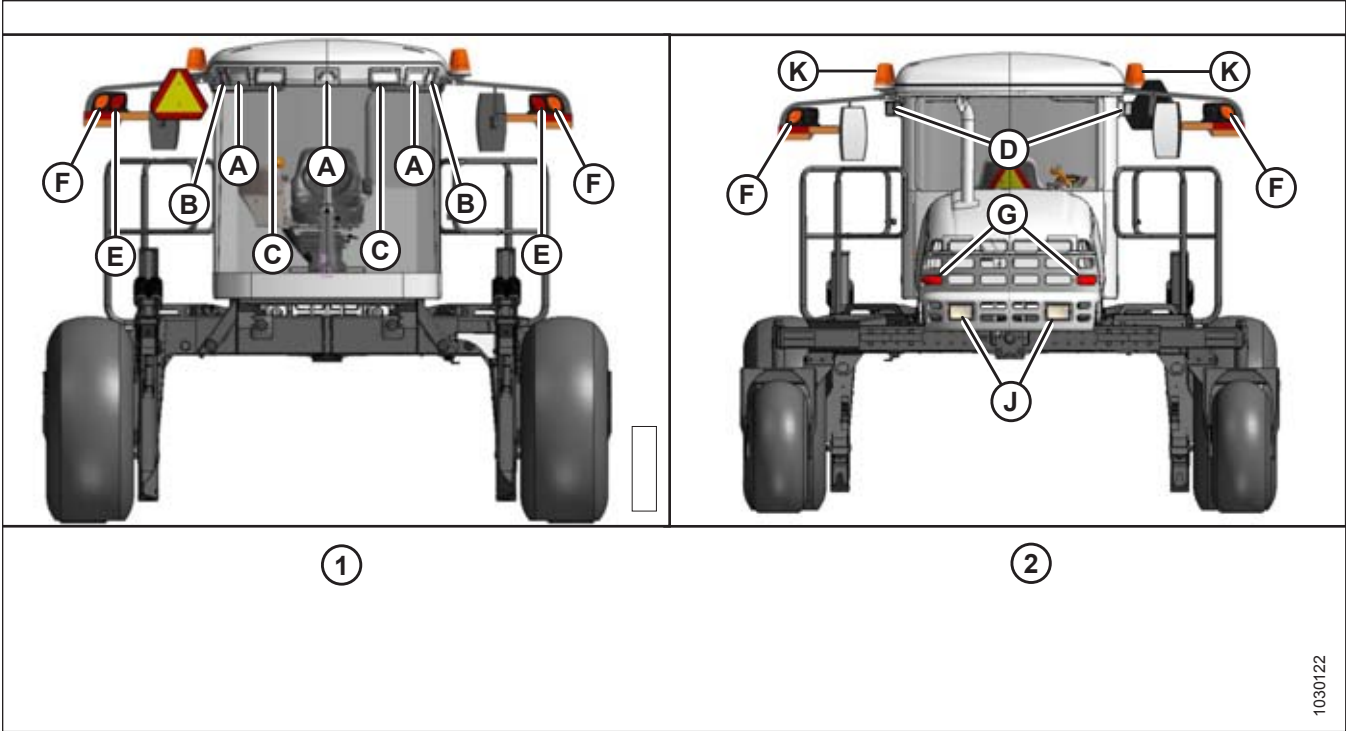

- 1 - Front
- B - Field/Road (Qty 2)
- E - Tail (Qty 2)
- H - Header Lights (Not Shown)

- 2 - Rear
- C - Field/Road (Qty 2)
- F - Hazard/Turn Signals (Qty 2)
- J - Field (Qty 2)

- A - Field (Qty 3)
- D - Field (Qty 2)
- G - Tail (Qty 2)
- K - Beacons (Qty 2)

1030122

3.7.3 Engine-Forward Lighting

This section explains the lighting defaults with the windrower in engine-forward mode.

Table 3.2 Engine-Forward Lighting

Switch Position ⇄ Lights ↓	Auto Road Inactive		Auto Road Active ⁷	
	Field	Road	Field	Road
Field (A)	ON	ON	ON	ON
Tail (B)	ON ⁸	ON ⁸	ON ⁸	ON ⁸
Hazard/turn signal (C)	CDM switched	CDM switched	CDM switched	CDM switched
Tail (D) (cab-forward only)	OFF	OFF	OFF	OFF
Tail on header (not shown)	ON	ON	ON	ON
Road (E)	ON in high or low beam	ON in high or low beam	ON in high or low beam	ON in high or low beam
Beacon (F)	ON or OFF	ON or OFF	ON	ON

Figure 3.20: Engine-Forward Lighting

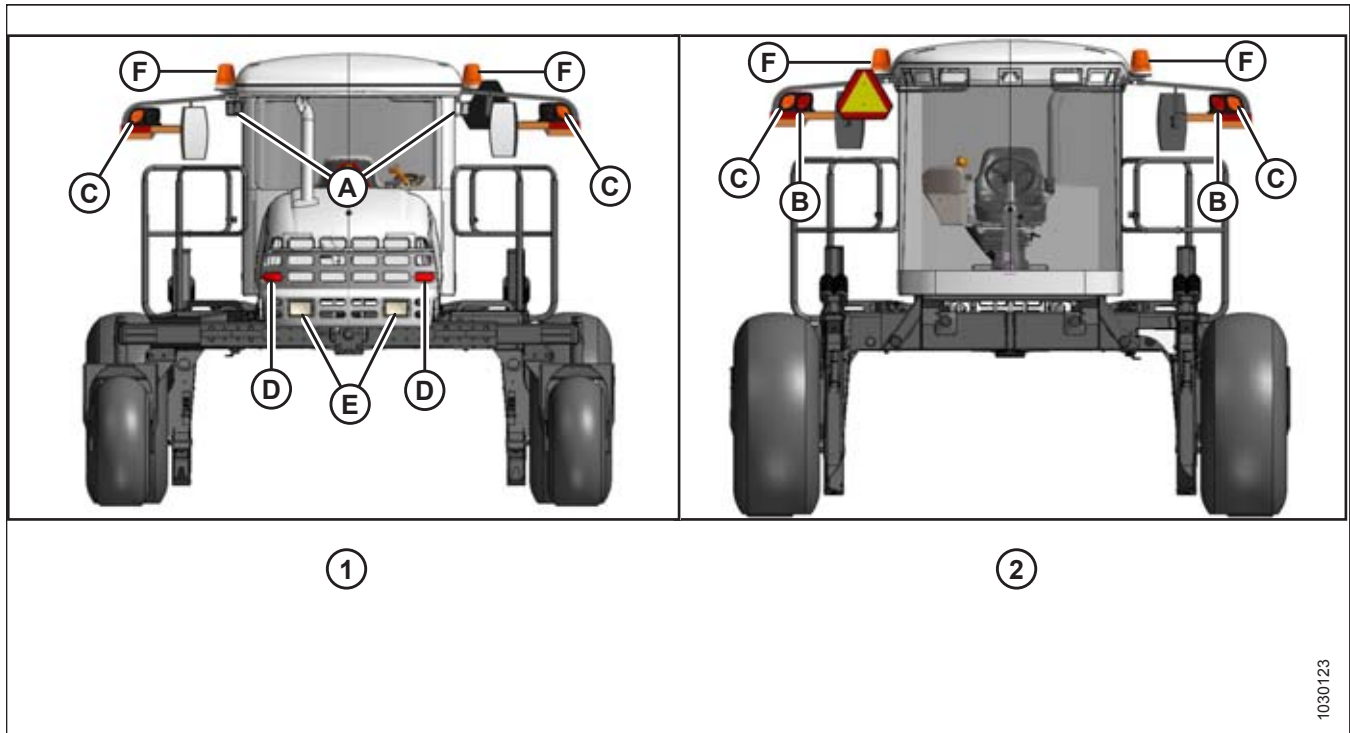

1 - Front
C - Hazard/Turn Signals (Qty 2)

2 - Rear
D - Tail (Qty 2)

A - Field (Qty 2)
E - Road (Qty 2)

B - Tail (Qty 2)
F - Beacons (Qty 2)

1030123

7. Engine running, transmission in mid-range, header disengaged
8. Only with beacon switch ON.

3.7.4 HID Auxiliary Lighting (Optional)

Two optional high intensity discharge (HID) lights (MD #B5596) provide additional lighting during field operation.

If installed, HID auxiliary lighting is located on the mirror supports (A) and operates in cab-forward mode only.

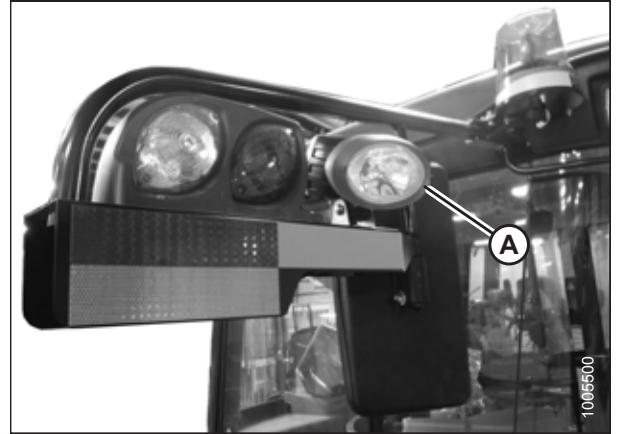

Figure 3.21: HID Auxiliary Lights (Optional)

Optional HID auxiliary lighting is activated with the light switch (B) in the FIELD position.

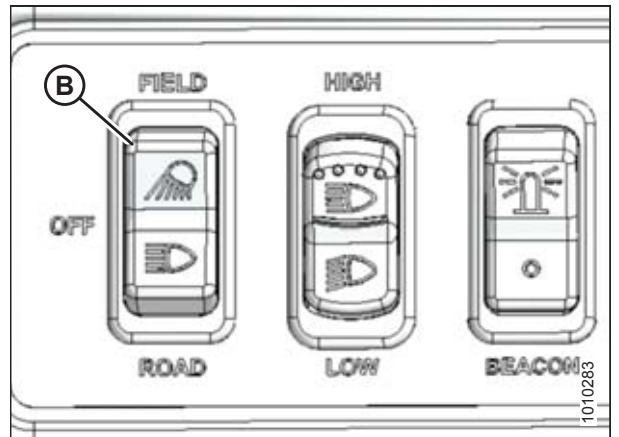

Figure 3.22: Field Light Switch (except Russia)

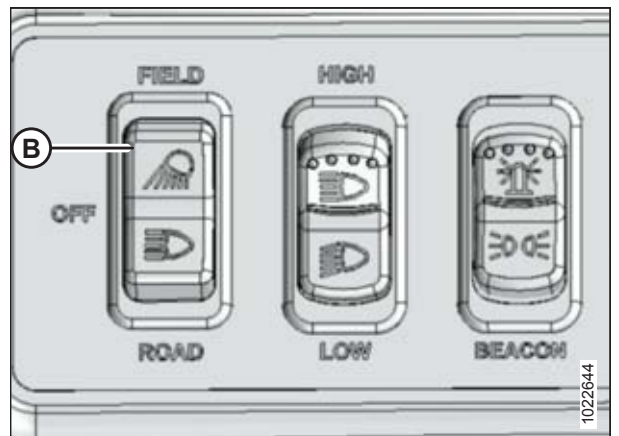

Figure 3.23: Field Light Switch (Russia)

3.8 Windshield Wipers

The windshield wiper controls are located in the cab headliner. The illustration shows the controls in cab-forward mode.

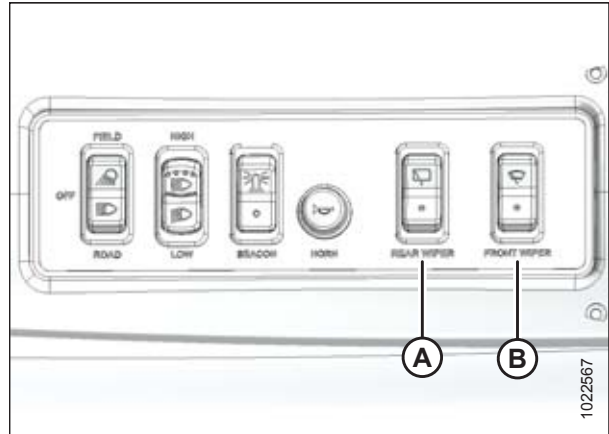

Figure 3.24: Wiper Controls

A - Rear Wiper

B - Front Wiper

3.9 Rearview Mirrors

Two outside-mounted, adjustable mirrors (A) provide a rear view when the windrower is in cab-forward mode.

A single interior-mounted mirror (B) provides a rear view in the engine-forward mode.

The mirror/light assembly (A) is designed to fold back if accidentally struck. A detent-type lock keeps it in place.

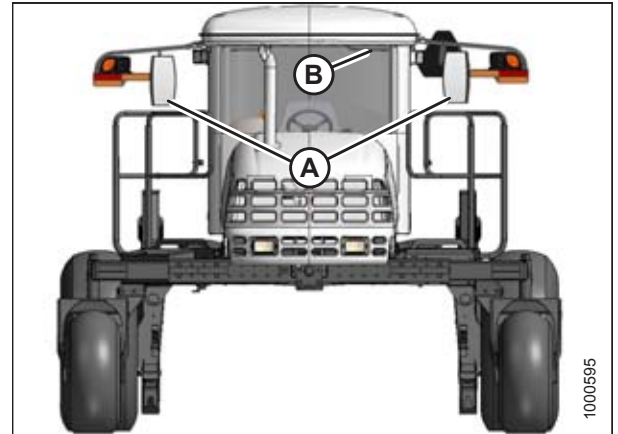

Figure 3.25: Mirrors

3.10 Cab Temperature

The cab environment is controlled by a climate control system that provides clean air-conditioned or heated air.

The heater/evaporator/blower assembly is located under the cab floor and is accessible from beneath the windrower.

3.10.1 Heater Shut-Off

A shut-off valve (A) at the engine allows the cab heater to be isolated from the engine coolant.

The valve must be OPEN to provide heat to the cab, but can be CLOSED for maximum cooling.

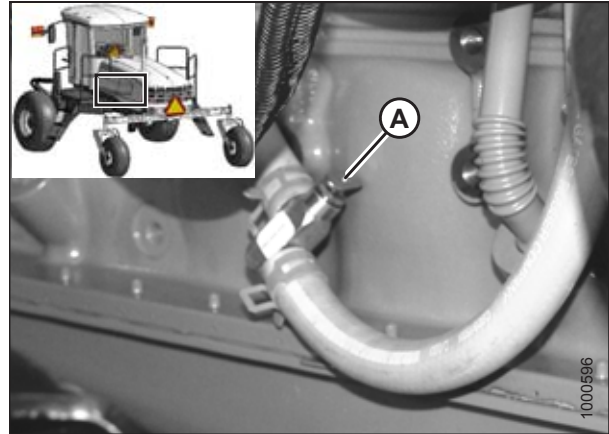

Figure 3.26: Heater Shut-Off Valve

3.10.2 Air Distribution

Cab air distribution is controlled through adjustable air vents (A) located in the cab posts. The vents provide Operator ventilation.

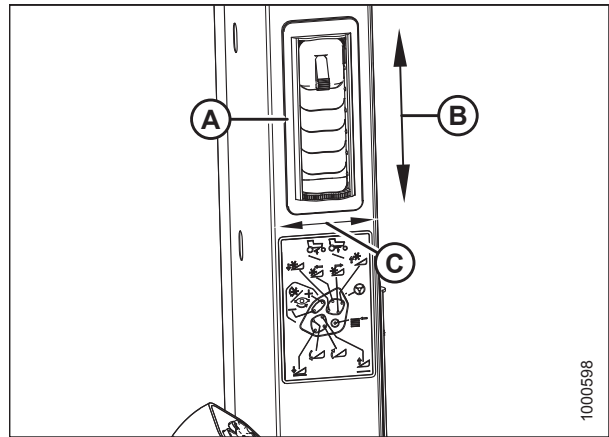

Figure 3.27: Adjustable Air Vents

A - Vent B - Open/Close C - Direction

3.10.3 Climate Controls

A – BLOWER Switch controls the blower speed

- OFF / LOW / MEDIUM / HIGH

B – Air Conditioning (A/C) Switch controls A/C system

- OFF: A/C does not operate
- ON: A/C operates with blower switch ON

C – Outside Air Switch controls the air source

- FRESH AIR: Starts booster fan and filtered outside air is drawn into cab
- RECIRCULATE: Stops booster fan and cab air is recirculated

D – TEMPERATURE Control Dial controls cab temperature

- Turning the dial clockwise increases temperature
- Turning the dial counterclockwise decreases temperature

IMPORTANT:

When starting the windrower after more than one week of storage, the refrigerant oil needs to be distributed through the A/C system. For instructions, refer to [Air Conditioning Compressor Coolant Cycling, page 161](#).

Refrigerant Oil

Perform the following steps when starting the windrower after more than one week of storage to distribute the refrigerant oil throughout the A/C system:

1. Ensure heater shut-off valve at engine is OPEN. Refer to [3.10.1 Heater Shut-Off, page 56](#).
2. Turn blower switch to the first position, turn temperature control switch to MAXIMUM heating, and A/C control to OFF.
3. Start the engine and operate at low idle until the engine is warm.
4. Click A/C switch from OFF to ON for 1 second, then back to OFF for 5 to 10 seconds. Repeat this step ten times.

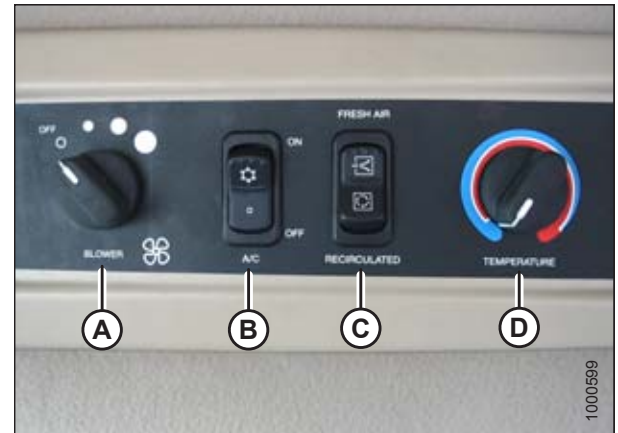

Figure 3.28: Climate Controls

3.11 Interior Lights

Two interior lights are installed in the cab headliner.

A low intensity LED light (A) is located directly overhead to provide ambient lighting if desired. It functions only when the key is in the RUN position. An ON/OFF switch is located on the light.

The other interior light (B) is located on the headliner switch panel and the push-ON, push-OFF button is located on the light. It functions at any time.

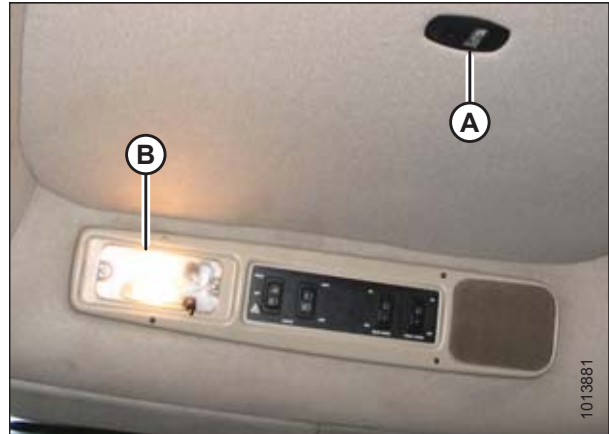

Figure 3.29: Interior Lights

3.12 Emergency Exit

The emergency exit window (indicated by the emergency exit decal [A]) is located beside the operator's station.

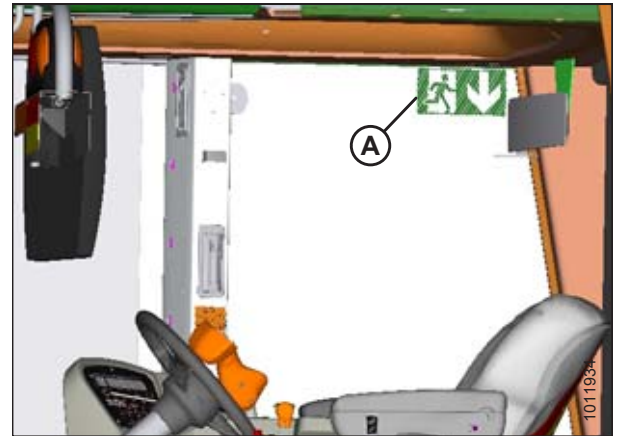

Figure 3.30: Emergency Exit Sign

To open the emergency exit window, follow these steps:

1. Release the window latch (A).
2. Remove the latch pin (B).
3. Push window open (C).

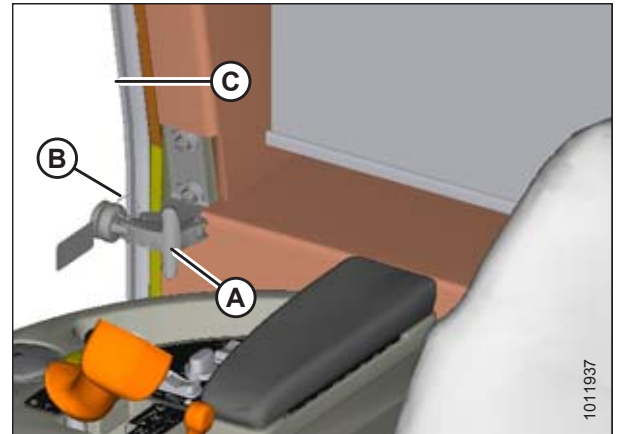

Figure 3.31: Emergency Exit Window

3.13 Operator Amenities

The operator's station includes the following amenities:

Operator's console

- A - Auxiliary power outlet
- B - Utility tray (under armrest)
- C - Cigarette lighter
- D - Ashtray/cup holder
- E - Utility tray

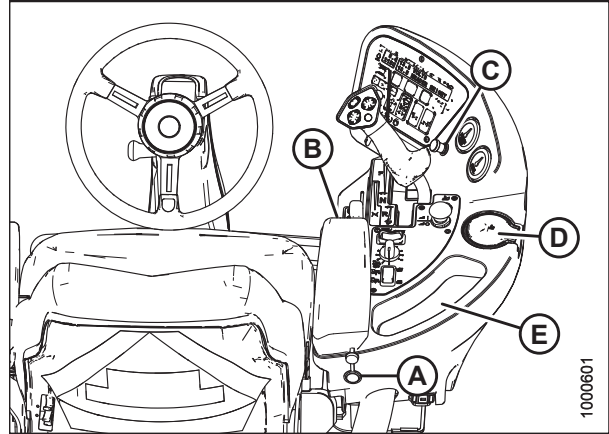

Figure 3.32: Console

Windshield shades (optional)

Retractable window shades (A) can be installed for the front and rear windows. Refer to [7.1.5 Windshield Shades, page 461](#) for ordering information.

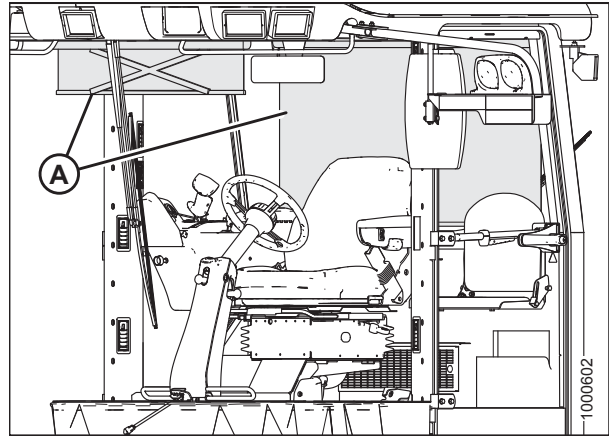

Figure 3.33: Windshield Shades

Auxiliary outlets

Two auxiliary power outlets are located on either side of the wiper motor cover/storage tray behind the Operator (cab-forward mode).

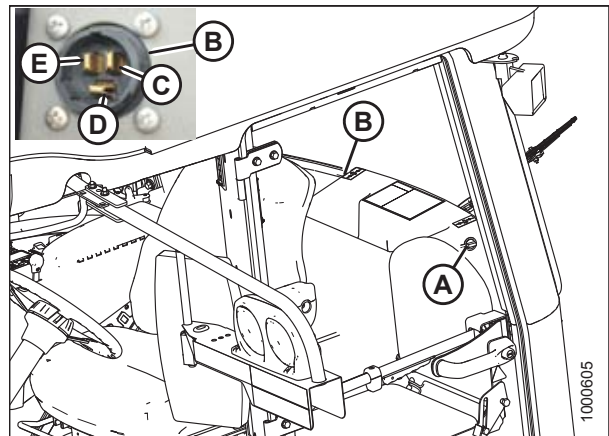

Figure 3.34: Auxiliary Power Outlets

- A - Auxiliary Power Outlet
- B - Auxiliary Power Outlet
- C - Battery Terminal
- D - Ground Terminal
- E - Switched Terminal

OPERATOR'S STATION

Manual storage

A manual storage case (A) is located under the training seat.

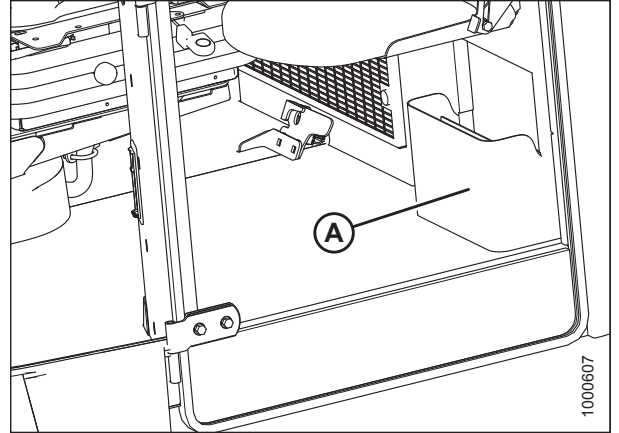

Figure 3.35: Operator's Manual Storage

Coat hook

A coat hook (A) is located above the training seat, left of the Operator.

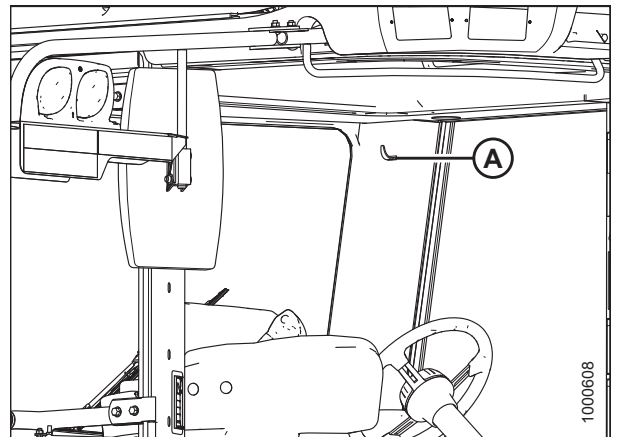

Figure 3.36: Coat Hook

3.14 Radio

A radio is available as optional equipment from your Dealer.

3.14.1 AM/FM Radio

A space (B) is provided in the cab headliner to accommodate the installation of an AM/FM radio. In order to retain radio settings and preset memory with the battery disconnect turned off, select a radio with non-volatile settings memory.

Two pre-wired speakers (A) have been factory-installed in the headliner.

For radio installation procedures, refer to the windrower unloading and assembly instructions.

Operating instructions are supplied with the radio.

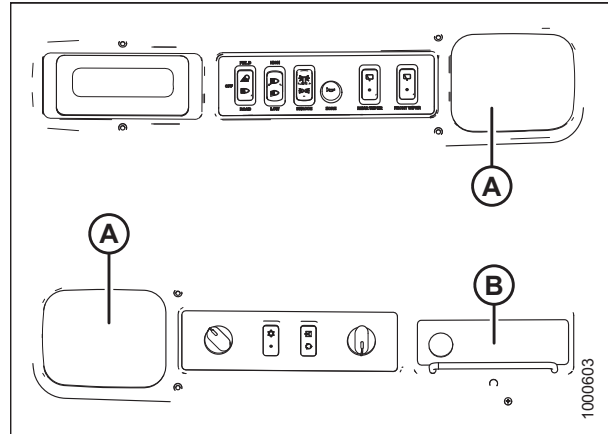

Figure 3.37: Speakers in Headliner

A - Speakers

B - Radio Mounting Location

3.14.2 Mounting the Antenna

An optional base for a magnetic, roof-mounted antenna is available from your Dealer.

IMPORTANT:

The antenna base can only be installed on the left cab-forward and right rear cab roof bolts.

Order antenna mount (MD #160288 [B]) or refer to [3.40, page 63](#) for part dimensions to make an improvised version. A knockout (C) for the antenna lead is provided on the cab post, as shown in the following illustration.

1. Remove existing bolt (A).
2. Install antenna mount (B) and secure with bolt (A).

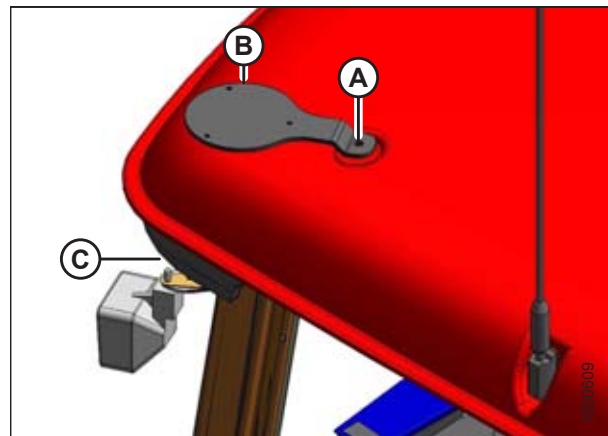

Figure 3.38: Antenna Mount

OPERATOR'S STATION

The knockout (A) is located on the exterior right cab-forward rear corner post of the cab, under the roof, between the horn and the light.

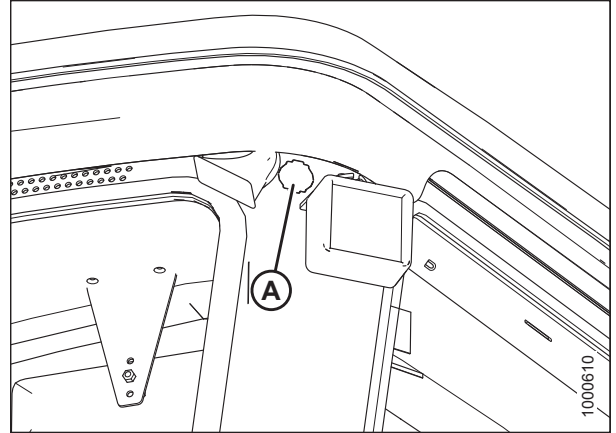

Figure 3.39: Knockout Location in Cab

To make your own mount, refer to dimensions template.
Use 11 GA. or 3.0 mm steel sheet.

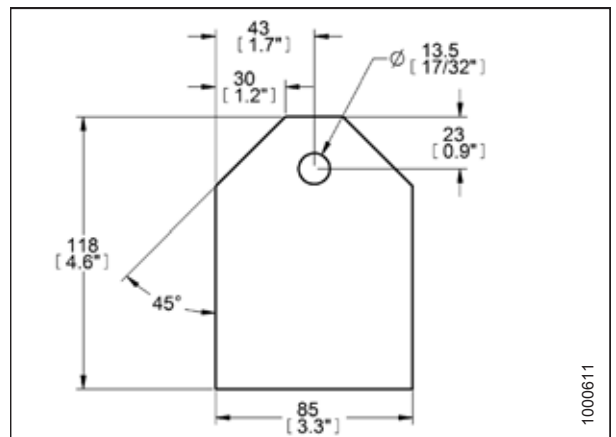

Figure 3.40: Template for Antenna Mount

3.15 Horn

The horn is activated by pushing button (A) located beside the ignition key.

Sound the horn three times prior to starting the engine.

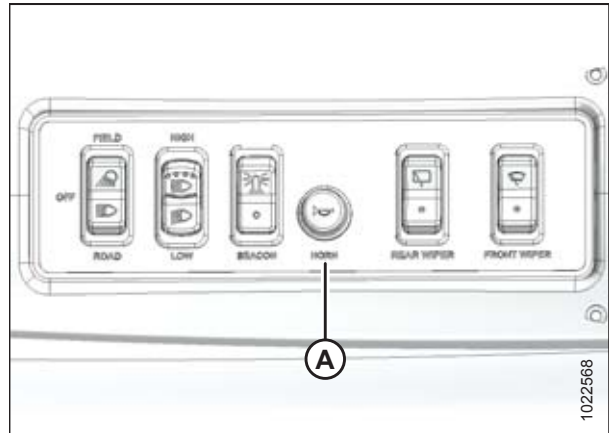

Figure 3.41: Horn Button Location

The horn (A) is located outside the cab on the rear right cab-forward corner of the cab, under the roof.

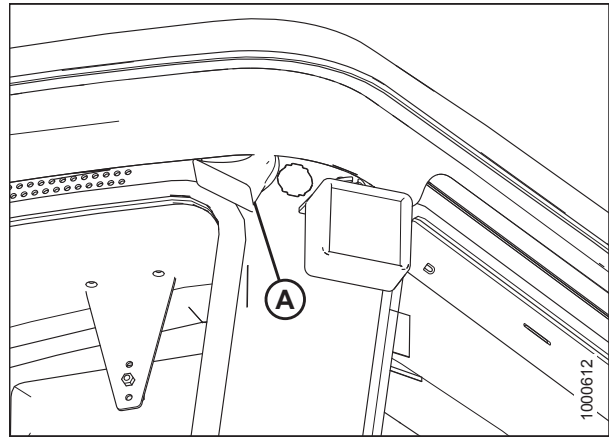

Figure 3.42: Horn Location

3.16 Engine Controls and Gauges

The following engine controls and gauges are conveniently located on the operator's console.

Ignition switch (A)

- ACC (Accessory): Fully counterclockwise
- OFF: All electrical systems OFF
- RUN: Clockwise
- START: Fully clockwise to crank engine: Release and switch returns to RUN

NOTE:

Remove key when windrower is not in use; the key also locks doors.

- Fuel level monitoring
- DEF monitoring
- High Exhaust System Temp indicator (HEST)
- Selective Catalytic Reduction (SCR) system cleaning inhibit and forced indicator

Engine coolant temperature gauge (B)

- Normal Running: 82°–104°C (180°–220°F)

NOTE:

For information about temperature warnings and alarms, refer to *Display Warnings and Alarms*, page 85.

Fuel gauge (C)

- E: Empty
- F: Full

Throttle (D) controls engine speed

- FULL: Push lever forward
- OPERATING: Refer to *Driving Forward in Cab-Forward Mode*, page 172
- CLOSED: Pull lever back



Figure 3.43: Engine Controls and Gauges

3.17 Windrower Controls

Console controls:

A – TURN SIGNALS activate turn signals on windrower and header

- Push-ON/Push-OFF

B – GROUND SPEED LEVER (GSL) controls speed and direction of movement

- F: Forward
- N: NEUTRAL
- N-DETENT: Engages neutral interlock, and applies park brake when steering locked in center
- R: Reverse

C – HAZARD WARNING LIGHTS activate signals on windrower and header

- Push-ON/Push-OFF

D – GROUND SPEED RANGE SWITCH shifts transmission speed range

- High range: 0–37 km/h (23 mph) ENGINE-FORWARD ONLY
- Mid range: 0–25.7 km/h (16 mph) CAB-FORWARD ONLY
- Low range: 0–17.7 km/h (11 mph)

E – N-DETENT

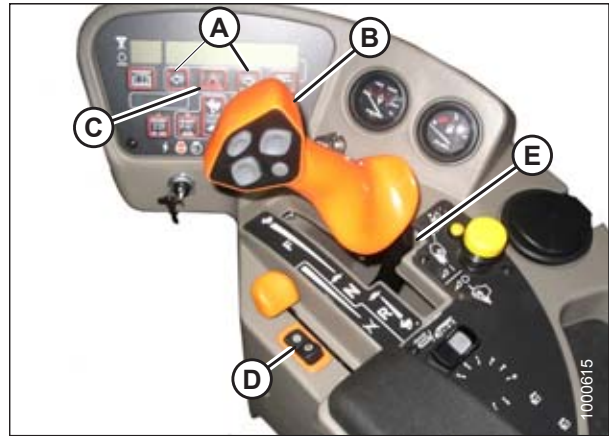

Figure 3.44: Console Controls

OPERATOR'S STATION

Autosteer control:

A – AUTOSTEER ENGAGEMENT SWITCH

engages/disengages the automated steering system (if compatible system is installed)

- ENGAGE: Click to engage
- DISENGAGE: Turn steering wheel or click to disengage

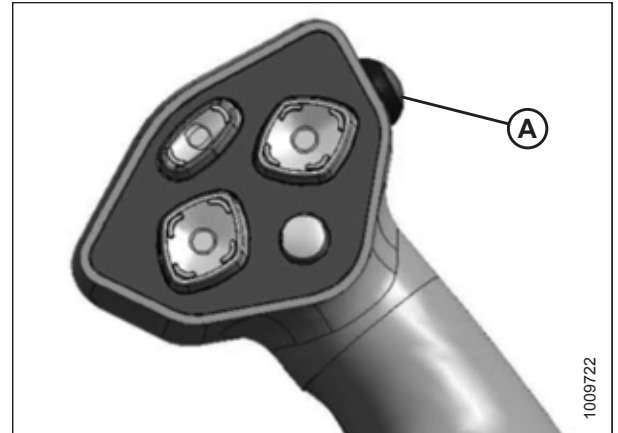

Figure 3.45: GSL

The autosteer engagement switch harness has two connectors and is located as follows:

GSL SW1 (A) is located in the cab, beneath the floor mat at the engine-end seat position switch.

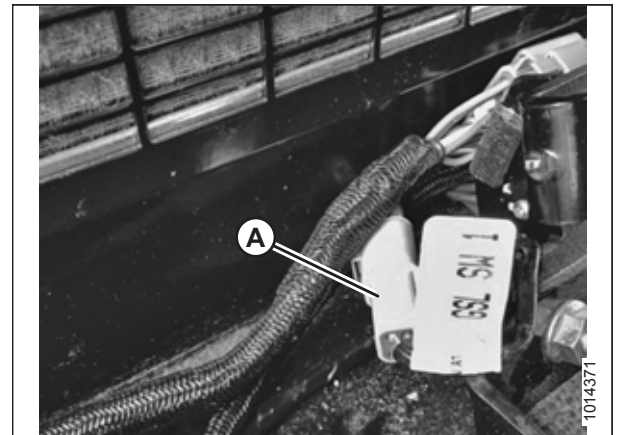

Figure 3.46: Autosteer Harness SW1

GSL SW2 (A) is located beneath the cab, between the fuel tank and evaporator box.

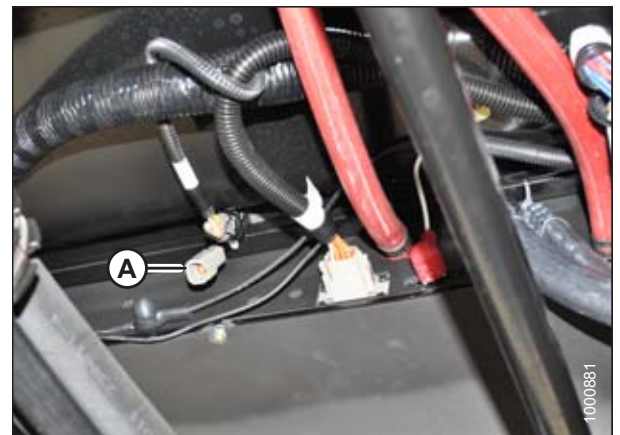

Figure 3.47: Autosteer Harness SW2

3.18 Header Controls

All header controls are conveniently located on the operator's console and on the ground speed lever (GSL) handle.

NOTE:

Some controls are optional equipment and may not be present in your unit. Some controls may be installed, but nonfunctional for certain headers.

Refer to specific header sections in this manual for detailed header operating procedures.

3.18.1 Header Drive Switch

The HEADER DRIVE switch (A) engages and disengages the header drive.

To engage the header drive, pull up on collar (B) and push down on switch (A).

To disengage the header drive, push the switch down.

IMPORTANT:

Always move throttle lever back to IDLE before engaging header drive. Do **NOT** engage header with engine at full rpm.

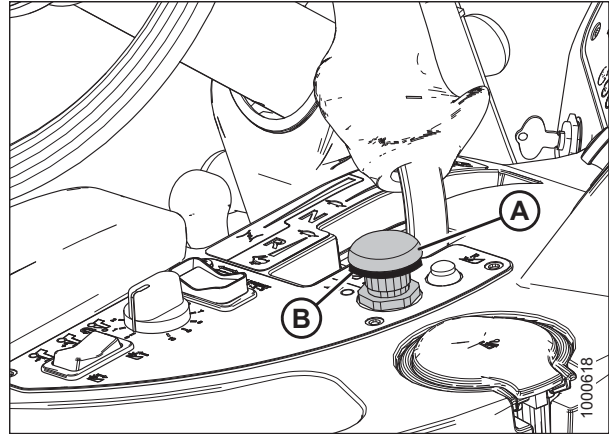

Figure 3.48: Header Drive Switch

3.18.2 Header Drive Reverse Button

NOTE:

The hydraulic reversing kit must be installed on auger headers and on draper headers with a conditioner.

- ENGAGE: Push and hold REVERSER button (B) and engage header with switch (A)
- DISENGAGE: Release REVERSER Button (B)

NOTE:

To engage forward operation, push switch (A) down and then up again.

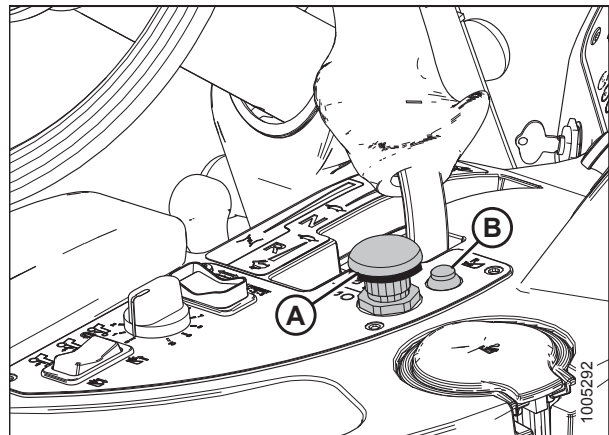

Figure 3.49: Header Drive Switches

3.18.3 Ground Speed Lever Header Switches

The switches on the ground speed lever (GSL) (A) control the most common header functions.

NOTE:

A decal (B) identifying switch functions is located on the cab post above the operator's console.

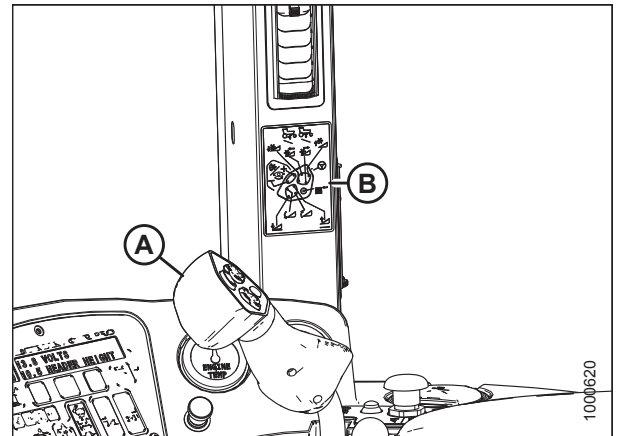

Figure 3.50: GSL

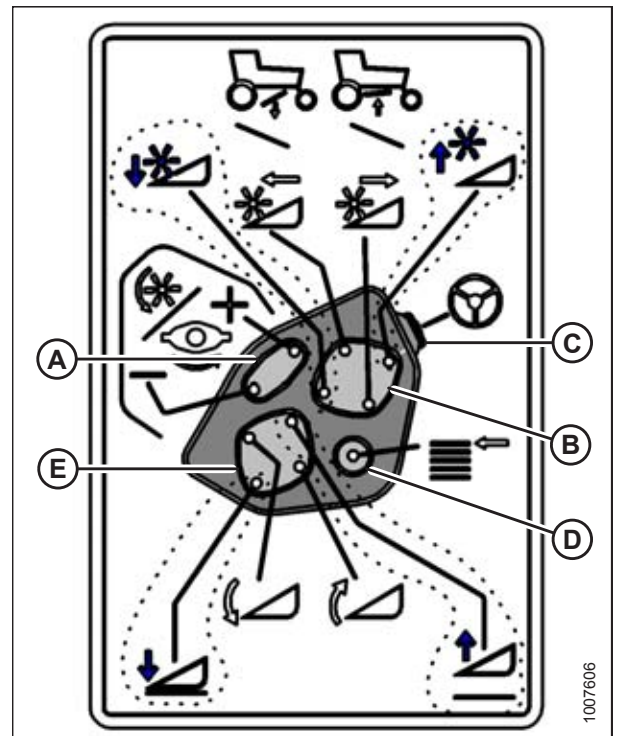

Figure 3.51: GSL Function Groups

- | | |
|--------------------------|----------------------|
| A - Reel Speed | B - Reel Position |
| C - Autosteer Engagement | D - Display Selector |
| E - Header Position | |

OPERATOR'S STATION

Display Selector Switch

Pressing the display selector switch (A) selects and displays the settings on the cab display module (CDM) top line read-out for each of the header controls.

Press switch (A) to scroll through settings.

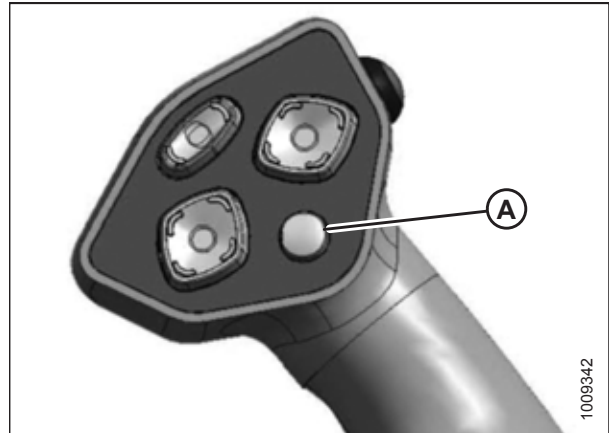

Figure 3.52: Ground Speed Lever

Header Position Switches

Use the header position switches on the ground speed lever (GSL) to adjust the position of the header relative to the ground.

- To lower the header, press switch (A)
- To raise the header, press switch (C)
- To tilt the header down, press switch (B)
- To tilt the header up, press switch (D)

Release switch at desired position.

NOTE:

Refer to the section in this manual that is specific to your header for detailed switch operating modes.

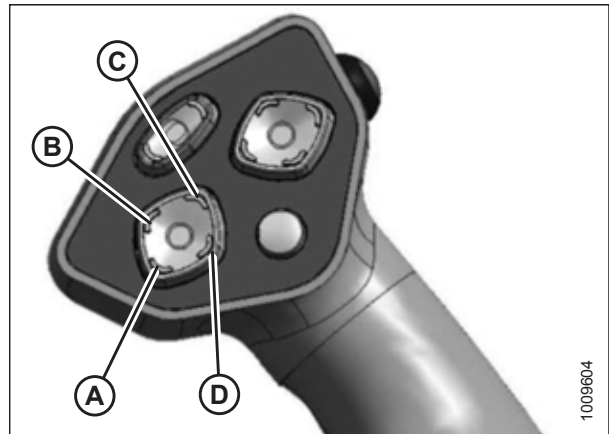

Figure 3.53: Ground Speed Lever

OPERATOR'S STATION

Reel and Disc Speed Switches

Press and hold switch (A) to increase the reel or disc speed.
Press and hold switch (B) to decrease the reel or disc speed.
Release switch at desired speed.

Auger header

- A30D header: Not applicable
- A40D header: Auger speed is automatically maintained when reel speed is changed

IMPORTANT:

Reel speed on auger header **MUST NOT EXCEED** 85 rpm.
Auger speed **MUST NOT EXCEED** 320 rpm.

Draper header

- Reel speed is limited in INDEX HEADER SPEED mode

Rotary disc header

- Conditioner speed automatically adjusts when DISC SPEED is changed

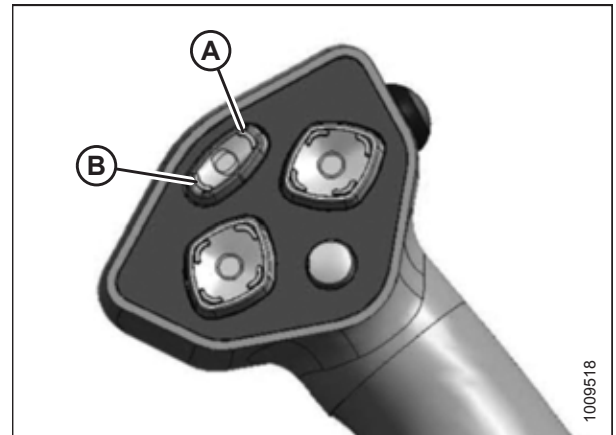

Figure 3.54: Ground Speed Lever

3.18.4 Console Header Switches

The operator's console contains switches for the following header functions:

Deck Shift / Float Preset Switch

Draper header with deck shift option

Controls deck shifting and float settings for double windrowing options with a draper header.

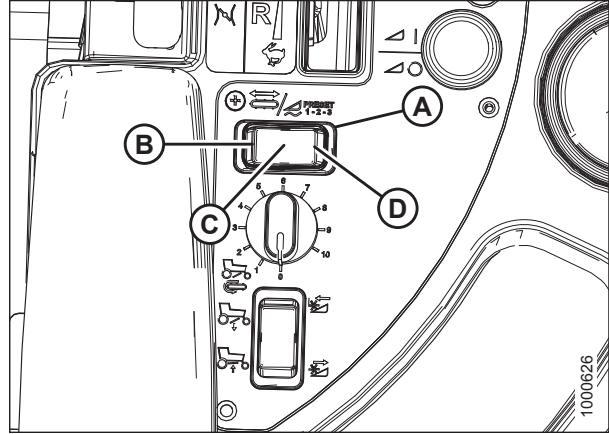

Figure 3.55: Header Switches

- A - Deck Shift / Float Preset Switch
- B - Left-Side Delivery
- C - Center Delivery
- D - Right-Side Delivery

Draper header with fixed decks / auger header / rotary header

Selects preprogrammed header float settings. Refer to [Float Options, page 201](#) to learn how to preset the float.

NOTE:

Refer to the section in this manual that is specific to your header for detailed switch operating modes.

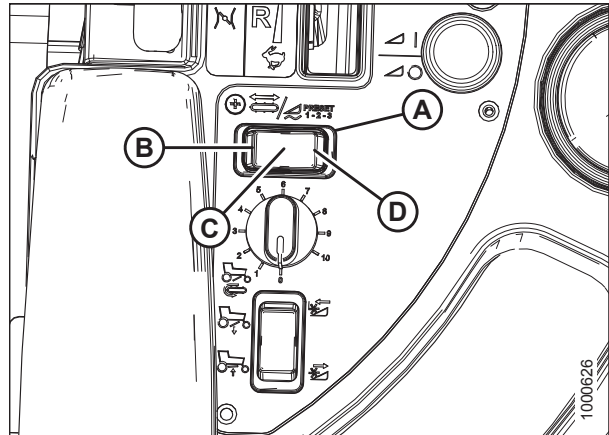

Figure 3.56: Header Switches

- A - Deck Shift / Float Preset Switch
- B - Float Preset 1
- C - Float Preset 2
- D - Float Preset 3

3.19 Cab Display Module (CDM)

3.19.1 Engine and Windrower Functions

Figure 3.57: Cab Display Module (CDM) Engine and Windrower Functions



- (A) ENGINE RPM
- (B) GROUND SPEED – km/h or mph
- (C) DISPLAY – Engine/windrower functions
- (D) HAZARD WARNING LIGHTS SWITCH – Activates hazard warning lights, cancels turn signal
- (E) SELECT SWITCH – Allows Operator to select display item on lower line. Push to SELECT
- (F) TURN SIGNAL SWITCHES – Activates turn signals on windrower and header. Push-ON/Push-OFF
- (G) IGNITION SWITCH POSITIONS – Accessory / Stop / Run / Start
- (H) ENGINE WARNING LIGHTS – Engine Pre-Heat / Water In Fuel / CAUTION / Stop Engine

3.19.2 Header Functions

Figure 3.58: Cab Display Module (CDM)



- (A) DISPLAY – Header functions.
- (B) SELECT SWITCH – Allows Operator to select display item on lower line. Push to SELECT.
- (C) FLOAT SWITCH – Header Right Side: Changes header float. The system remembers setting with deck shift option if activated with float setting switch. Push + to Increase. Push – to Decrease.
- (D) FLOAT SWITCH – Header Left Side: Changes header float. The system remembers setting with deck shift option if activated with float setting switch. Push + to Increase. Push – to Decrease.
- (E) AUGER/DRAPER SPEED ADJUST: Changes auger/drapper speed INDEX with INDEX SWITCH ON. Changes auger/drapper SPEED with INDEX SWITCH OFF. Push upper switch to increase. Push lower switch to decrease.
- (F) HEADER INDEX SWITCH: Links reel and conveyor speed to ground speed. Push-ON/Push-OFF.

NOTE:

Illuminates in ON position. (Header must be engaged)

- (G) RETURN TO CUT HEIGHT SWITCH: Allows cutting height preset. Push-ON/Push-OFF.

NOTE:

Illuminates in ON position (Header must be engaged).

3.19.3 Operating Screens

The cab display module (CDM) and the windrower control module (WCM) provide information on several functions for the engine, header, and windrower. The information displayed in various operating modes is described in the following sections.

Figure 3.59: CDM Operating Screen



A - Display Selector for Upper Line
D - CDM Lower Line

B - Display
E - Display Selector for Lower Line

C - CDM Upper Line

Ignition ON, Engine Not Running

Display (Upper Line) (2–3 Seconds)	Description
HEADER DISENGAGED	Indicates HEADER DRIVE switch is OFF
IN PARK	Indicates ground speed lever (GSL) is in N-DETENT

Engine Running – At Initial Start Up

Display (Upper Line) (2–3 seconds)	Description
HEADER TYPE AND SIZE	Ignition start, engine running
IN PARK	Indicates ground speed lever (GSL) in N-DETENT. On startup

OPERATOR'S STATION

Engine-Forward, Engine Running

Display	Description
ROAD GEAR (upper line)	low-speed range in HIGH range
#####.# ENGINE HRS (upper or lower line)	Total engine operating time
#####.# UNIT HRS (upper or lower line)	Total windrower operating time
#####.# HEADER HRS (upper or lower line)	Total header operating time
#####.# TOTAL ACRES (upper or lower line) #####.# TOTAL HECT (if metric)	Total area cut by machine
##.# HEADER HEIGHT (upper or lower line)	Distance setting (00.0–10.0) between cutterbar and ground
##.# HEADER ANGLE (upper or lower line)	Angle setting (00.0–10.0) header relative to ground
### °C or F HYD OIL TEMP	Hydraulic oil temperature
##.# VOLTS (upper or lower line)	Engine electrical system operating voltage
##.# SWATH COMPR HT	Swath compressor height (00.0–10.0); fully raised is 0
SCROLL (lower line)	Displays above items after 2 to 3 seconds; press SELECT to cancel

Cab-Forward, Engine Running, Header Disengaged

Scroll through display with cab display module (CDM) switch or ground speed lever (GSL) switch.

Display (Lower or Upper Line)	Description
#####.# ENGINE HRS	Total engine operating time
#####.# UNIT HRS	Total windrower operating time
#####.# HEADER HRS	Total header operating time
###.# SUB ACRES ###.# SUB HECTARES (if metric)	Area cut since last reset. To reset, display SUB ACRES on lower line, and hold down PROGRAM switch until display resets (5 to 7 seconds)
#####.# TOTAL ACRES #####.# TOTAL HECT (if metric)	Total area cut by machine
##.# HEADER HEIGHT	Distance setting (00.0–10.0) between cutterbar and ground
##.# HEADER ANGLE	Angle setting (00.0–10.0) header relative to ground
##.# L FLOAT R ##.#	Float setting (0.0–10.0)
### °C or F HYD OIL TEMP	Hydraulic oil temperature
##.# VOLTS	Engine electrical system operating voltage
##.# SWATH COMPR HT	Swath compressor height (00.0–10.0); fully raised is 0
SCROLL (lower line)	Displays above items after 2 to 3 seconds; press SELECT to cancel

OPERATOR'S STATION

Cab-Forward, Engine Running, Header Engaged, Auger Header Index Switch OFF

Scroll through display with cab display module (CDM) switch or ground speed lever (GSL) switch.

Display (Lower or Upper Line)	Description
#####.# ENGINE HRS	Total engine operating time
#####.# UNIT HRS	Total windrower operating time
#####.# HEADER HRS	Total header operating time
##.# ACRES/HOUR ##.# HECTARES/HOUR (if Metric)	Actual cutting rate in acres (hectares)/hour
###.# SUB ACRES ###.# SUB HECTARES (if Metric)	Area cut since last reset; to reset, display SUB ACRES on lower line, and hold down PROGRAM switch until display resets (5 to 7 seconds)
##### TOTAL ACRES ##### TOTAL HECT (if Metric)	Total area cut by machine
##.## REEL RPM ##.## REEL SENSOR	Reel rotational speed Sensor disabled. RPM and SENSOR alternate at 1 second intervals
##.# AUGER SPEED	Auger rotational speed (4.7–9.9)
#### KNIFE SPEED #### KNIFE SENSOR	Knife speed in strokes per minute Sensor disabled. SPEED and SENSOR alternate at 1 second intervals
##.# HEADER HEIGHT ##.# HEADER SENSOR	Distance setting (00.0–10.0) between cutterbar and ground Sensor disabled. HEIGHT and SENSOR alternate at 1 second intervals
##.# HEADER ANGLE ##.# HEADER SENSOR	Angle setting (00.0–10.0) header relative to ground Sensor disabled. ANGLE and SENSOR alternate at 1 second intervals
##.# L FLOAT R ##.# FLOAT SENS DISABLED	Left and right float setting (0.0–10.0) Sensor disabled
LOAD ■■■■ #####	Bar graph representing hydraulic operating pressure. Full scale is preprogrammed overload pressure (17,237–34,474 kPa [2500–5000 psi]). If sensor disabled, LOAD does not display ⁹
###.# °C or F HYD OIL TEMP ###.# °C or F HYD TEMP	Hydraulic oil temperature Sensor disabled. TEMP and SENSOR alternate at 1 second intervals
##.# VOLTS	Engine electrical system operating voltage
##.# SWATH COMPR HT SWATH CO SENSOR	Swath compressor height (00.0–10.0); fully raised is 0 Sensor disabled
SCROLL SUB-MENU (lower line only) #### KNIFE SPEED ##.# HEADER HEIGHT LOAD ■■■■ ■■■■ #####	Displays sub-menu after 2 to 3 seconds. Press SELECT to cancel. Scroll through sub-menu display with CDM switch

9. The LOAD sensor to monitor knife/conditioner circuit pressure is optional. To monitor reel/auger circuit pressure, relocate sensor as per kit instruction MD #169031, which is available through your Dealer.

OPERATOR'S STATION

Cab-Forward, Engine Running, Header Engaged, Auger Header Index Switch ON

Scroll through display with cab display module (CDM) switch or ground speed lever (GSL) switch.

Display (Lower or Upper Line)	Description
#####.# ENGINE HRS	Total engine operating time
#####.# UNIT HRS	Total windrower operating time
#####.# HEADER HRS	Total header operating time
##.# ACRES/HOUR ##.# HECTARES/HOUR (if metric)	Actual cutting rate in acres (hectares)/hour
###.# SUB ACRES ###.# SUB HECTARES (if metric)	Area cut since last reset; to reset, display SUB ACRES on lower line, and hold down PROGRAM switch until display resets 5 to 7 seconds)
##### TOTAL ACRES ##### TOTAL HECT (if metric)	Total area cut by machine
##.## ##.# REEL IND. ##.## REEL SENSOR	Reel peripheral speed along with ground speed in mph or km/h Sensor disabled. IND and SENSOR alternate at 1 second intervals
##.# AUGER SPEED ##.# AUGER SENSOR	Auger rotational speed (4.7–9.9) Sensor disabled. SPEED and SENSOR alternate at 1 second intervals
##### KNIFE SPEED ##### KNIFE SENSOR	Knife speed In strokes per minute Sensor disabled. SPEED and SENSOR alternate at 1 second intervals
##.# HEADER HEIGHT ##.# HEADER SENSOR	Distance setting (00.0–10.0) between cutterbar and ground Sensor disabled. HEIGHT and SENSOR alternate at 1 second intervals
##.# HEADER ANGLE ##.# TILT SENSOR	Angle setting (00.0–10.0) header relative to ground. Sensor disabled. ANGLE and SENSOR alternate at 1 second intervals
##.# L FLOAT R ##.# FLOAT SENS DISABLED (if sensor disabled)	Left and right float setting (0.0–10.0) Sensor disabled
LOAD ■■■■ #####	Bar graph representing hydraulic operating pressure. Full scale is preprogrammed overload pressure (17,237–34,474 kPa [2500–5000 psi]). If sensor disabled, LOAD does not display ¹⁰
###.# °C or F HYD OIL TEMP ###.# °C or F HYD TEMP	Hydraulic oil temperature Sensor disabled. TEMP and SENSOR alternate at 1 second intervals
##.# VOLTS	Engine electrical system operating voltage

10. The LOAD sensor to monitor knife/conditioner circuit pressure is optional. To monitor reel/auger circuit pressure, relocate sensor as per kit instruction MD #169031, which is available through your Dealer.

OPERATOR'S STATION

Display (Lower or Upper Line)	Description
##.# SWATH COMPR HT SWATH CO SENSOR	Swath compressor height (00.0–10.0); fully raised is 0 Sensor disabled
SCROLL SUB-MENU (lower line only) #### KNIFE SPEED ##.# HEADER HEIGHT LOAD ■■■■ ■■■■ ####	Displays sub-menu after 2 to 3 seconds. Press SELECT to cancel. Scroll through sub-menu display with CDM switch

Engine Running, Header Engaged, Auger Header

Scroll through display with cab display module (CDM) switch or ground speed lever (GSL) switch.

Display (Lower or Upper Line)	Description
#####.# ENGINE HRS	Total engine operating time
#####.# UNIT HRS	Total windrower operating time
#####.# HEADER HRS	Total header operating time
##.# ACRES/HOUR ##.# HECTARES/HOUR (if metric)	Actual cutting rate in acres (hectares)/hour
###.# SUB ACRES ###.# SUB HECTARES (if Metric)	Area cut since last reset
##### TOTAL ACRES ##### TOTAL HECT (if metric)	Total area cut by machine
###.# REEL RPM ###.# REEL SENSOR (flashing)	Reel rotational speed. Optional Sensor disabled.
##.# AUGER SPEED	Auger rotational speed (4.7–9.9)
#### KNIFE SPEED #### KNIFE SENSOR (flashing)	Knife speed In strokes per minute. Optional Sensor disabled
##.# HEADER HEIGHT ##.# HEADER SENSOR (flashing)	Distance setting (00.0–10.0) between cutterbar and ground Sensor disabled
##.# HEADER ANGLE ##.# ANGLE SENSOR	Angle setting (00.0–10.0) header relative to ground. Optional Sensor disabled
##.# VOLTS	Engine electrical system operating voltage
FUEL ■■■■ ■■■■	Level of fuel in tank
ENGINE TEMP ### °F ENGINE TEMP ### °C (if metric)	Engine coolant temperature
SCROLL SUB-MENU (lower line only) #### KNIFE SPEED ##.# AUGER SPEED ###.# REEL RPM ##.# HEADER HEIGHT	Displays sub-menu after 2–3 seconds. Press SELECT to cancel. Scroll through sub-menu display with CDM switch Knife speed is optional Reel rpm is optional

OPERATOR'S STATION

Cab-Forward, Engine Running, Header Engaged, Draper Header, Index Switch OFF

Scroll through display with cab display module (CDM) switch or ground speed lever (GSL) switch.

Display (Lower or Upper Line)	Description
#####.# ENGINE HRS	Total engine operating time
#####.# UNIT HRS	Total windrower operating time
#####.# HEADER HRS	Total header operating time
##.# ACRES/HOUR ##.# HECTARES/HOUR (if metric)	Actual cutting rate in acres (hectares)/hour
####.# SUB ACRES ####.# SUB HECTARES (if metric)	Area cut since last reset. To reset, display SUB ACRES on lower line, and hold down PROGRAM switch until display resets (5 to 7 seconds)
##### TOTAL ACRES ##### TOTAL HECT (if metric)	Total area cut by machine
###.## REEL MPH ###.## REEL KPH (if metric) ###.## REEL SENSOR (flashing)	Reel peripheral speed Sensor disabled. MPH or KPH and SENSOR alternate at 1 second intervals
##.# DRAPER SPEED	Draper speed (0.0–11.0)
#### KNIFE SPEED #### KNIFE SENSOR	Knife speed In strokes per minute Sensor disabled. SPEED and SENSOR alternate at 1 second intervals
##.# HEADER HEIGHT ##.# HEADER SENSOR	Distance setting (00.0–10.0) between cutterbar and ground Sensor disabled. HEIGHT and SENSOR alternate at 1 second intervals
##.# HEADER ANGLE ##.# HEADER SENSOR	Angle setting (00.0–10.0). Header relative to ground Sensor disabled. ANGLE and SENSOR alternate at 1 second intervals
##.# L FLOAT R ##.# FLOAT SENS DISABLED	Left and right float setting (0.0–10.0) Sensor disabled
### °C or F HYD OIL TEMP ### °C or F HYD SENSOR	Hydraulic oil temperature Sensor disabled. TEMP and SENSOR alternate at 1 second intervals
LOAD ■■■■ ####	Bar graph representing hydraulic operating pressure. Full scale is pre-programmed overload pressure (2500–5000 psi). If sensor disabled, LOAD does not display ¹¹
##.# VOLTS	Engine electrical system operating voltage
##.# SWATH COMPR HT SWATH CO SENSOR	Swath compressor height (00.0–10.0); fully raised is 0 Sensor disabled
SCROLL SUB-MENU (lower line only) #### KNIFE SPEED ##.# HEADER HEIGHT LOAD ■■■■ ■■■■ #### ###.## REEL MPH ##.# DRAPER SPEED	Displays sub-menu after 2 to 3 seconds. Press SELECT to cancel. Scroll through sub-menu display with CDM switch
KNIFE SPD OVERLOAD	Knife or disc speed drops below programmed value

11. The LOAD sensor to monitor knife/conditioner circuit pressure is optional. To monitor reel/auger circuit pressure, relocate sensor as per kit instruction MD #169031, which is available through your Dealer.

OPERATOR'S STATION

Cab-Forward, Engine Running, Header Engaged, Draper Header Index Switch ON

Scroll through display with cab display module (CDM) switch or ground speed lever (GSL) switch.

Display (Lower or Upper Line)	Description
#####.# ENGINE HRS	Total engine operating time
#####.# UNIT HRS	Total windrower operating time
#####.# HEADER HRS	Total header operating time
##.# ACRES/HOUR ##.# HECTARES/HOUR (if metric)	Actual cutting rate in acres (hectares)/hour
####.# SUB ACRES ####.# SUB HECTARES (if metric)	Area cut since last reset. To reset, display SUB ACRES on lower line and hold down PROGRAM switch until display resets (5 to 7 seconds)
##### TOTAL ACRES ##### TOTAL HECT (if metric)	Total area cut by machine
##.## ##.# REEL IND REEL.SENSOR	Reel peripheral speed along with ground speed in mph or km/h Sensor disabled. IND and SENSOR alternate at 1 second intervals
##.# ##.# DRAP INDX	Draper speed along with ground speed in mph or km/h
####.# KNIFE SPEED ####.# KNIFE SENSOR	Knife speed in strokes per minute. Sensor disabled SPEED and SENSOR alternate at 1 second intervals
##.# HEADER HEIGHT ##.# HEADER SENSOR	Distance setting (00.0–10.0) between cutterbar and ground Sensor disabled. HEIGHT and SENSOR alternate at 1 second intervals
##.# HEADER ANGLE ##.# HEADER SENSOR	Angle setting (00.0–10.0) header relative to ground Sensor disabled. ANGLE and SENSOR alternate at 1 second intervals
##.# L FLOAT R ##.# FLOAT SENS DISABLED	Left and right float setting (0.0–10.0) Sensor disabled
LOAD ■■■■ #####	Bar graph representing hydraulic operating pressure. Full scale is preprogrammed overload pressure (17,237–34,474 kPa [2500–5000 psi]). If sensor disabled, LOAD does not display ¹²
##.# VOLTS	Engine electrical system operating voltage
##.# SWATH COMPR HT SWATH CO SENSOR	Swath compressor height (00.0–10.0); fully raised is 0. Sensor disabled
SCROLL SUB-MENU (lower line only) ####.# KNIFE SPEED ##.# HEADER HEIGHT LOAD ■■■■ ■■■■ ##.## ##.# REEL IND ##.# ##.# DRAP INDX	Displays sub-menu after 2 to 3 seconds. Press SELECT to cancel Scroll through sub-menu display with CDM switch
##.## REEL MIN RPM (lower line)	Reel speed drops below programmed set-point
MINIMUM (lower line)	Reel speed at zero ground speed

12. The LOAD sensor to monitor knife/conditioner circuit pressure is optional. To monitor reel/auger circuit pressure, relocate sensor as per kit instruction MD #169031, which is available through your Dealer.

OPERATOR'S STATION

Cab-Forward, Engine Running, Header Engaged, Rotary Header Installed

Scroll through display with cab display module (CDM) switch or ground speed lever (GSL) switch.

Display (Lower or Upper Line)	Description
#####.# ENGINE HRS	Total engine operating time
#####.# UNIT HRS	Total windrower operating time
#####.# HEADER HRS	Total header operating time
##.# ACRES/HOUR ##.# HECTARES/HOUR (if metric)	Actual cutting rate in acres (hectares)/hour
####.# SUB ACRES ####.# SUB HECTARES (if metric)	Area cut since last reset; to reset, display SUB ACRES on lower line, and hold down PROGRAM switch until display resets (5 to 7 seconds)
##### TOTAL ACRES ##### TOTAL HECT (if metric)	Total area cut by machine
#### DISC RPM ##.## DISC SENSOR	Disc rotational speed Sensor disabled. RPM and SENSOR alternate at 1 second intervals
##.# HEADER HEIGHT ##.# HEIGHT SENSOR	Distance setting (00.0–10.0) between cutterbar and ground Sensor disabled. HEIGHT and SENSOR alternate at 1 second intervals
##.# HEADER ANGLE ##.# HEADER SENSOR	Angle setting (00.0–10.0) header relative to ground Sensor disabled. ANGLE and SENSOR alternate at 1 second intervals
##.# L FLOAT R ##.# FLOAT SENS DISABLED	Left and right float setting (0.0–10.0) Sensor disabled
LOAD ■■■■ #####	Bar graph representing hydraulic operating pressure. Full scale is preprogrammed overload pressure (17,237–34,474 kPa [2500–5000 psi]). If sensor disabled, LOAD does not display ¹³
### °C or F HYD OIL TEMP ### °C or F HYD TEMP	Hydraulic oil temperature Sensor disabled. TEMP and SENSOR alternate at 1 second intervals
##.# VOLTS	Engine electrical system operating voltage
##.# SWATH COMPR HT SWATH CO SENSOR	Swath compressor height (00.0–10.0); fully raised is 0 Sensor disabled
SCROLL SUB-MENU (lower line only) #### DISC RPM ##.# HEADER HEIGHT LOAD ■■■■ ■■■■ #####	Displays sub-menu after 2 to 3 seconds. Press SELECT to cancel. Scroll through sub-menu display with CDM switch

13. The LOAD sensor to monitor knife/conditioner circuit pressure is optional-installed. To monitor reel/auger circuit pressure, relocate sensor as per kit instruction MD #169031, which is available through your Dealer.

OPERATOR'S STATION

Miscellaneous Operational Information

Scroll through display with cab display module (CDM) switch or ground speed lever (GSL) switch.

Display (Upper Line)	Description
HEADER DISENGAGED	Header drive is disengaged
##.# FOOT DISK	AUGER or DRAPER will appear in place of DISK, depending on type of header attached
IN PARK	GSL in N-DETENT position
< LEFT TURN ■	Indicates left turn when left arrow is pressed on CDM (engine-forward mode only ¹⁴)
■ RIGHT TURN >	Indicates right turn when right arrow is pressed on CDM (engine-forward mode only ¹⁵)
■ HAZARD ■	Indicates hazard warning lights are on when hazard button is pressed on CDM
HEADER REVERSE	Header drive running in reverse
HEADER ENGAGED	Header drive engaged
ROAD GEAR	With HIGH RANGE selected on console switch (engine-forward only ¹⁵)

14. If road light kit is not installed, CDM will display E135 LEFT STOP LAMP as a malfunction in cab-forward mode.

15. If road light kit is not installed, CDM will display E134 RIGHT STOP LAMP as a malfunction in cab-forward mode.

3.19.4 Cab Display Module Warning and Alarms

The cab display module (CDM) displays warnings and sounds alarms to notify of abnormal windrower status at startup when the ignition is turned ON, and at engine operating speeds above 500 rpm.

Engine Warning Lights

Figure 3.60: CDM Engine Warning Lights



A - Engine Preheat
D - Stop

B - Water in Fuel
E - Display

C - Caution

- ENGINE PRE-HEAT: Illuminates yellow. Wait to start engine.
- WATER IN FUEL: Illuminates yellow. Service recommended.
- CAUTION: Illuminates yellow. Prompt attention is required. Refer to display code.
- STOP: Illuminates red. Stop engine immediately. Refer to display code.
- DISPLAY: Displays malfunction code. Refer to [8.4 Engine Error Codes, page 482](#) or your Dealer.

OPERATOR'S STATION

Display Warnings and Alarms

The cab display module (CDM) warnings and alarms indicate abnormal windrower conditions.

Figure 3.61: CDM Display Warnings and Alarms



Display (A)	Flashing	Alarm Tone	Description
BRAKE OFF	X	Short beep with each flash	Engine running, GSL in N-DETENT, brake pressure switch or brake switch relay fault
BRAKE ON	X	Short beep with each flash	Ground speed lever (GSL) out of N-DETENT, but interlock switch remains closed to apply brake
BRAKE SW FAILURE	X	Short beep with each flash	Ignition ON/engine not running, brake switch and relay closed
CAB-FORWARD SW ON/ ENG-FORWARD SW ON	X	Messages flash alternately	Both seat switches activated
CENTER STEERING		Two beeps per second	GSL or interlock switches not closed with key ON/engine OFF
DISENGAGE HEADER RE-ENGAGE <1800 RPM>	X	None	R80/R85 - Engine rpm above 1800 rpm when engaging header
ENGINE AIR FILTER	X	Single loud tone for 10 seconds, Repeats every 30 minutes until condition is corrected	Engine air filter requires servicing
ENGINE TEMPERATURE	X	Ongoing intermittent moderate tone until temperature is below 102°C (215°F)	Engine temperature over 104°C (220°F)

OPERATOR'S STATION

Display (A)	Flashing	Alarm Tone	Description
HEADER DISENGAGED		None	Normal
DISENGAGE HEADER	X	None	Header switch is in the ON position when ignition switch is turned ON
HEADER OIL PRESS	X	Continuous loud tone until oil pressure is regained	Low header charge oil pressure causes header to shut down: header ON switch must be moved to OFF position and then to ON position to restart the header
HYDRAULIC FILTER	X	Single loud tone for 10 seconds, Repeats every 15 minutes until condition is corrected	Excessive pressure increase across hydraulic oil filter
### °C or F HYD OIL COLD	X	Tone sounds with each flash for 5 seconds and then stops for 1 minute, flashing continues if oil still cold after 1 minute, tone sounds again	Hydraulic oil temp <10°C (50°F)
### °C or F HYD OIL HOT	X	Tone with each flash for 5 seconds at 104°C (220°F) then tone stops for 1 minute while flashing continues. If oil still hot after 1 minute, tone sounds again. Flashing and steady tone at temperatures of 110°C (230°F) and higher	Hydraulic oil temp >104°C (220°F) but <110°C (230°F)
IN PARK	X	One short beep	GSL in N-DETENT, steering wheel centered, and brakes are engaged
KNIFE SPEED OVERLOAD	X	Short beep with each flash until condition is corrected	Machine overload: knife or disc speed drops below programmed value
LOCK SEAT BASE	X	None	Seat base not detected in cab or engine-forward position
LOW HYDRAULIC OIL	X	Continuous loud tone for 5 seconds. If condition is not rectified, single loud tone every 5 minutes	Low hydraulic oil level, header shuts down automatically if engaged: Header ON switch must be moved to OFF position and then to ON position to restart the header
NO HEADER		None	Header is not detected

OPERATOR'S STATION

Display (A)	Flashing	Alarm Tone	Description
NO OPERATOR		Continuous tone	Operator not detected in seat with header engaged or out of N-DETENT: engine shutdown after 5 seconds
NO OPERATOR ENGINE SHUT DOWN		Continuous tone	Engine shutdown when Operator not detected in seat with machine moving under 8 km/h (5 mph)
NOT IN PARK	X	Short beep with each flash	GSL or interlock switches not closed with key ON/engine OFF
PLACE GSL INTO N		Two beeps per second	GSL or interlock switches not closed with key ON/engine OFF
SLOW DOWN	X	Short beep with each flash	Ground speed is greater than or equal to 40 km/h (25 mph): Operator should pull back on the GSL to reduce ground speed
TRANS OIL PRESS	X	Continuous loud tone until oil pressure is regained	Low transmission charge oil pressure
##.# LOW VOLTS	X	Single loud tone for 10 seconds	Voltage below 11.5
##.# HIGH VOLTS	X	Single loud tone for 10 seconds	Voltage above 15.5

3.19.5 Cab Display Module – Configuration Guidelines

To ensure accurate monitoring, every header you attach to the windrower must be configured in the CDM. Use the following guidelines when configuring the CDM:

- The **HEADER MUST BE ATTACHED TO THE WINDROWER** so the CDM recognizes the header type.
- The transmission must be in Neutral (GSL in N-DETENT) to configure the system with the engine running.
- The ignition switch must be in the RUN position to configure the system when the engine is not running.
- The system only needs to be configured once for each header. Most functions are factory preset, but the Operator can make changes to suit windrowing conditions or modifications to the machine.
- The windrower input values are provided in this manual. Header function values are in the header operator's manual.
- The CDM must be in programming mode to view the program menus. Press PROGRAM and SELECT simultaneously on the CDM to enter programming mode. Exit programming mode at any time by pressing PROGRAM or by turning ignition to OFF.
- Refer to [3.19.6 Cab Display Module – Configuration Functions, page 88](#) for a detailed list of menu items.

NOTE:

Contact your MacDon Dealer for information about software updates to the electronic modules. Your Dealer will have the necessary interface tools and access to the latest software upgrades.

3.19.6 Cab Display Module – Configuration Functions

The configuration functions accessible from the cab display module (CDM) are shown and explained below.

Figure 3.62: CDM



A - Side Display

B - Main Display

C - Select Switch

D - Menu Item Scroll Forward

E - Menu Item Scroll Backward

F - Program Switch

Side Display: Displays software revision status.

- Upper line – C### (CDM)
- Lower line – M### (WCM)

Main Display: Displays menu item and selection¹⁶.

- Upper line – Menu item
- Lower line – Selection

Select Switch: Places monitor into program mode with PROGRAM switch. Press to accept menu item and advance to next item.

Menu Item Scroll Forward: Displays value under menu item.

- Push to scroll forward
- Hold down for fast scroll¹⁷

16. The current selection flashes.

17. Fast scroll applies only when changing KNIFE SPEED, OVERLOAD PRESSURE, and TIRE SIZE.

OPERATOR'S STATION

Menu Item Scroll Backward: Displays value under menu item.

- Push to scroll backward
- Hold down for fast scroll¹⁷

Program Switch: Places monitor into program mode. Press while pressing select switch.

NOTE:

Contact your MacDon Dealer for information regarding software updates to the electronic modules. Your Dealer will have the necessary interface tools and access to the latest software upgrades.

NOTE:

The following menus are available when ignition key is set to RUN:

- WINDROWER SETUP
- CAB DISPLAY SETUP
- DIAGNOSTIC MODE

The CALIBRATE SENSORS menu is available only when engine is running.

3.19.7 Cab Display Options

The display and sound features of the cab display module (CDM) are adjustable.

NOTE:

The following procedures are current for CDM software version C512 and windrower control module (WCM) M236. The WCM is supplied preloaded with the latest released version of the operating software. Any subsequent updates will be made available via internet download from the MacDon Dealer Portal (<https://portal.macdon.com>).

NOTE:

Pages may appear differently if running newer or older versions of software, and not all features are available on every machine.

OPERATOR'S STATION

Setting the Cab Display Language

1. Turn ignition key to RUN, or start the engine.
2. Press PROGRAM (A) and SELECT (B) on cab display module (CDM) to enter programming mode.
 - WINDROWER SETUP? is displayed on the upper line.
 - NO/YES is displayed on the lower line.



Figure 3.63: Windrower Setup Display

3. Press SELECT (A) until CAB DISPLAY SETUP? is displayed on the upper line.
 - NO/YES is displayed on the lower line.



Figure 3.64: Cab Setup Display

4. Press right arrow (C) to select YES. Press SELECT (D).
 - DISPLAY LANGUAGE? is displayed on the upper line.
 - Default language is displayed on the lower line.
5. Press left arrow (B) or right arrow (C) to select preferred language.

NOTE:

Language options that may be available are English, Russian, and Spanish.

6. Press PROGRAM (A) to exit programming mode or press SELECT (D) to proceed to next CAB DISPLAY SETUP? action.



Figure 3.65: Language Display

OPERATOR'S STATION

Changing the Windrower Display Units

1. Turn ignition key to RUN, or start the engine.
2. Press PROGRAM (A) and SELECT (B) on cab display module (CDM) to enter programming mode.
 - WINDROWER SETUP? is displayed on the upper line.
 - NO/YES is displayed on the lower line.



Figure 3.66: CDM Programming Buttons

3. Press SELECT (B) until CAB DISPLAY SETUP? is displayed on the upper line.
 - NO/YES is displayed on the lower line.
4. Press right arrow (A) to select YES. Press SELECT (B).
 - DISPLAY LANGUAGE? is displayed on the upper line.



Figure 3.67: Cab Display Setup

5. Press SELECT (D) until DISPLAY UNITS? is displayed on the upper line.
 - Default setting is displayed on the lower line.
6. Press left arrow (B) or right arrow (C) to select either METRIC or IMPERIAL speed display.
7. Press PROGRAM (A) to exit programming mode or press SELECT (D) to proceed to next CAB DISPLAY SETUP? action.



Figure 3.68: Display Units

OPERATOR'S STATION

Adjusting the Cab Display Buzzer Volume

1. Turn ignition key to RUN, or start the engine.
2. Press PROGRAM (A) and SELECT (B) on cab display module (CDM) to enter programming mode.
 - WINDROWER SETUP? is displayed on the upper line.
 - NO/YES is displayed on the lower line.



Figure 3.69: CDM Programming Buttons

3. Press SELECT (B) until CAB DISPLAY SETUP? is displayed on the upper line.
 - NO/YES is displayed on the lower line.
4. Press right arrow (A) to select YES. Press SELECT (B).
 - DISPLAY LANGUAGE? is displayed on the upper line.



Figure 3.70: Cab Display Setup

5. Press SELECT (D) until BUZZER VOLUME is displayed on the upper line.
 - Previous setting is displayed on the lower line.
6. Press left (B) or right (C) arrows to adjust buzzer volume.
7. Press PROGRAM (A) to exit programming mode or press SELECT (D) to proceed to next CAB DISPLAY SETUP? action.

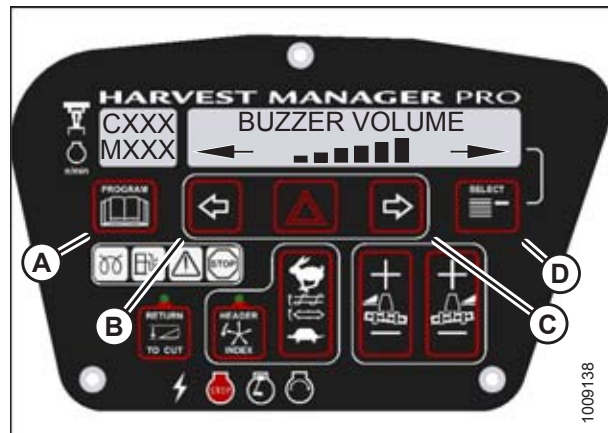

Figure 3.71: Buzzer Volume

OPERATOR'S STATION

Adjusting the Cab Display Backlighting

The backlighting feature brightens the display screen helping you read the cab display module (CDM) in low light situations.

1. Turn ignition key to RUN, or start the engine.
2. Press PROGRAM (A) and SELECT (B) on cab display module (CDM) to enter programming mode.
 - WINDROWER SETUP? is displayed on the upper line.
 - NO/YES is displayed on the lower line.



Figure 3.72: CDM Programming Buttons

3. Press SELECT (B) until CAB DISPLAY SETUP? is displayed on the upper line.
 - NO/YES is displayed on the lower line.
4. Press right arrow (A) to select YES. Press SELECT (B).
 - DISPLAY LANGUAGE? is displayed on the upper line.



Figure 3.73: Cab Display Setup

5. Press SELECT (D) until BACKLIGHTING is displayed on the upper line.
 - Default setting is displayed on the lower line.
6. Press left (B) or right (C) arrows to adjust display backlighting.
7. Press PROGRAM (A) to exit programming mode or press SELECT (D) to proceed to next CAB DISPLAY SETUP? action.

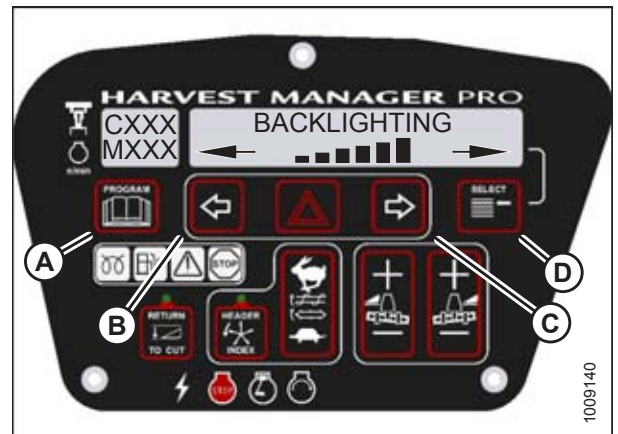

Figure 3.74: Display Backlighting Setting

OPERATOR'S STATION

Adjusting the Cab Display Contrast

1. Turn ignition key to RUN, or start the engine.
2. Press PROGRAM (A) and SELECT (B) on cab display module (CDM) to enter programming mode.
 - WINDROWER SETUP? is displayed on the upper line.
 - NO/YES is displayed on the lower line.



Figure 3.75: CDM Programming Buttons

3. Press SELECT (B) until CAB DISPLAY SETUP? is displayed on the upper line.
 - NO/YES is displayed on the lower line.
4. Press right arrow (A) to select YES. Press SELECT (B).
 - DISPLAY LANGUAGE? is displayed on the upper line.



Figure 3.76: Cab Display Setup

5. Press SELECT (D) until DISPLAY CONTRAST is displayed on the upper line.
 - Default setting is displayed on the lower line.
6. Press left (B) or right (C) arrows to adjust display contrast.
7. Press PROGRAM (A) to exit programming mode or press SELECT (D) to proceed to next CAB DISPLAY SETUP? action.

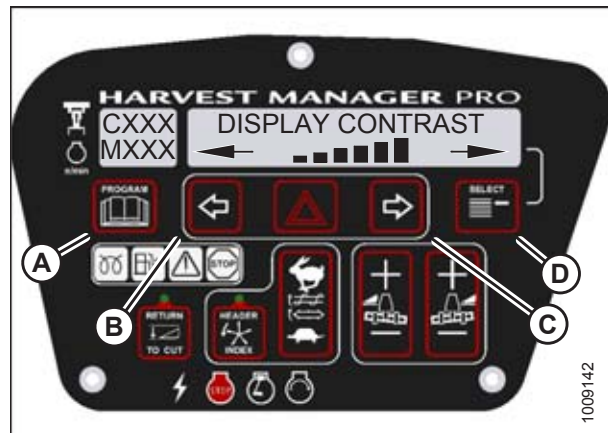

Figure 3.77: Display Contrast Setting

3.19.8 Configuring the Windrower

The windrower can be configured to meet changing crop conditions, activate newly added options, indicate a change of header type, or increase operator comfort level.

Setting the Header Knife Speed

This topic does not apply to rotary disc headers.

NOTE:

The header **MUST** be attached to the windrower to perform this procedure. The cab display module (CDM) automatically adjusts its programming for each header. For more information, refer to [4.5 Attaching and Detaching Headers, page 218](#).

1. Turn ignition key to RUN, or start the engine.
2. Press PROGRAM (A) and SELECT (C) on the cab display module (CDM) to enter programming mode.
 - WINDROWER SETUP? is displayed on the upper line.
 - NO/YES is displayed on the lower line.
3. Press right arrow (B) to select YES. Press SELECT (C).
 - SET KNIFE SPEED? is displayed.
 - The current knife speed is displayed on the lower line.



Figure 3.78: CDM Programming Buttons

4. Press left (B) or right (C) arrows to select knife speed. Press SELECT (D).
5. Press PROGRAM (A) to exit programming mode or press SELECT (D) to proceed to next WINDROWER SETUP action.

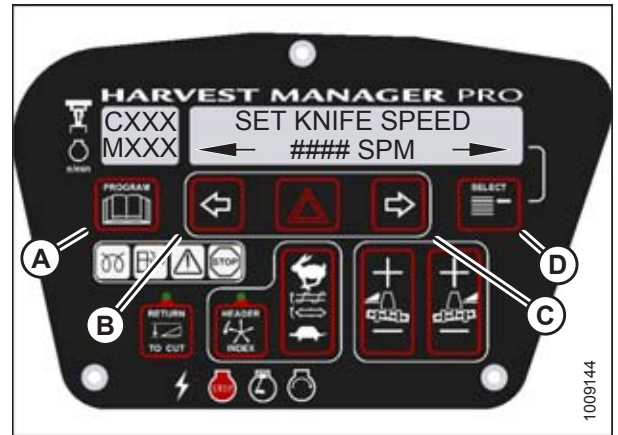

Figure 3.79: Knife Speed Setting

OPERATOR'S STATION

Setting the Knife Overload Speed

When the knife speed drops below the knife overload speed setting, this indicates the knife drive is overloaded, and a warning is displayed on the cab display module (CDM). The knife overload speed is set at 75% of knife speed.

NOTE:

- The header **MUST** be attached to the windrower to perform this procedure. The cab display module automatically adjusts its programming for each header. For more information, refer to [4.5 Attaching and Detaching Headers](#), page 218.

- The recommended knife overload speed is 75% of knife speed.

1. Turn ignition key to RUN, or start the engine.
2. Press PROGRAM (A) and SELECT (C) on the cab display module (CDM) to enter programming mode.
 - WINDROWER SETUP? is displayed on the upper line.
 - NO/YES is displayed on the lower line.
3. Press right arrow (B) to select YES. Press SELECT (C).
 - SET KNIFE SPEED? is displayed.

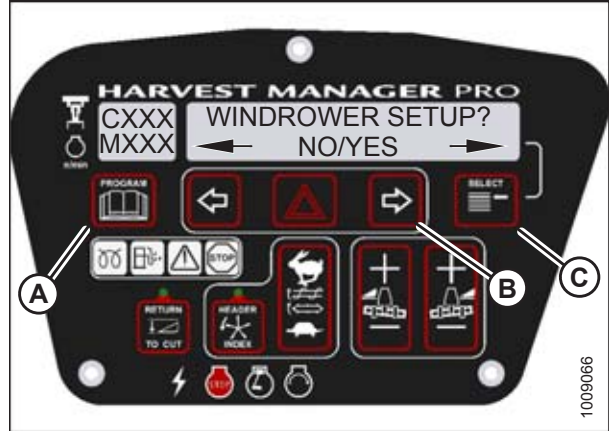

Figure 3.80: CDM Programming Buttons

4. Press SELECT (D) until KNIFE OVERLOAD SPD? is displayed on the upper line.
 - Current overload speed is displayed on the lower line.

NOTE:

Default setting is -300 spm. Range is -500 to -100 spm.

5. Press left (B) or right (C) arrows to set knife overload speed. Press SELECT (D).
6. Press PROGRAM (A) to exit programming mode or press SELECT (D) to proceed to next WINDROWER SETUP action.



Figure 3.81: Knife Overload Speed

OPERATOR'S STATION

Setting the Rotary Disc Overload Speed

This topic applies to rotary disc headers only.

When the rotary disc overload speed drops below the disc overload speed setting, this indicates the disc drive is overloaded, and a warning is displayed on the cab display module (CDM). The disc overload speed is set at 75% of knife speed.

NOTE:

- The header **MUST** be attached to the windrower to perform this procedure. The cab display module (CDM) automatically adjusts its programming for each header. For more information, refer to [4.5 Attaching and Detaching Headers, page 218](#).

- The recommended disc overload speed is 75% of disc speed. For more information, refer to the rotary disc header operator's manual to determine proper overload speed.

- Turn ignition key to RUN, or start the engine.
- Press PROGRAM (A) and SELECT (C) on the cab display module (CDM) to enter programming mode.
 - WINDROWER SETUP? is displayed on the upper line.
NO/YES is displayed on the lower line.
- Press right arrow (B) to select YES. Press SELECT (C).
 - SET KNIFE SPEED? is displayed.



Figure 3.82: CDM Programming Buttons

- Press SELECT (D) until DISC OVERLOAD SPD? is displayed on the upper line.
 - The current overload speed is displayed on the lower line.

NOTE:

Default setting is -300 rpm. Range is -500 to -100 rpm.

- Press left (B) or right (C) arrows to set disc overload speed. Press SELECT (D).
- Press PROGRAM (A) to exit programming mode or press SELECT (D) to proceed to next WINDROWER SETUP action.



Figure 3.83: Disc Overload Speed

OPERATOR'S STATION

Setting the Hydraulic Overload Pressure

The hydraulic overload pressure setpoint sets the upper limit of the pressure bar graph, which displays when the optional pressure sensor is enabled.

NOTE:

- This procedure requires installation of the optional pressure sensor (MD #B5574). For overload pressure values, refer to pressure sensor installation instructions (MD #169031).
- To enable sensor, refer to *Switching the Installed Header Sensors ON or OFF*, page 133.

1. Turn ignition key to RUN, or start the engine.
2. Press PROGRAM (A) and SELECT (C) on the cab display module (CDM) to enter programming mode.
 - WINDROWER SETUP? is displayed on the upper line.
 - NO/YES is displayed on the lower line.
3. Press right arrow (B) to select YES. Press SELECT (C).
 - SET KNIFE SPEED? is displayed.



Figure 3.84: CDM Programming Buttons

4. Press SELECT (D) until OVERLOAD PRESSURE? is displayed on the upper line.
 - The current overload pressure is displayed on lower line.

NOTE:

Pressure range is 17,237–34,474 kPa (2500–5000 psi).

5. Press left (B) or right (C) arrows to set hydraulic overload pressure. Press SELECT (D).
6. Press PROGRAM (A) to exit programming mode or press SELECT (D) to proceed to next WINDROWER SETUP action.



Figure 3.85: Hydraulic Overload Pressure

OPERATOR'S STATION

Setting the Header Index Mode

Index mode links reel and draper speed to ground speed. This feature is not applicable to rotary disc headers.

For more information on the Header Index feature, refer to [4.6.5 Reel Speed, page 291](#) and [4.6.6 Draper Speed, page 294](#).

NOTE:

The header **MUST** be attached to the windrower to perform this procedure. The cab display module (CDM) automatically adjusts its programming for each header. For more information, refer to [4.5 Attaching and Detaching Headers, page 218](#).

1. Turn ignition key to RUN, or start the engine.
2. Press PROGRAM (A) and SELECT (C) on the cab display module (CDM) to enter programming mode.
 - WINDROWER SETUP? is displayed on the upper line.
 - NO/YES is displayed on the lower line.
3. Press right arrow (B) to select YES. Press SELECT (C).
 - SET KNIFE SPEED? is displayed on the upper line.



Figure 3.86: CDM Programming Buttons

4. Press SELECT (D) until HEADER INDEX MODE? is displayed on the upper line.
 - REEL & CONVEYOR or REEL ONLY is displayed on the lower line.
5. Press left (B) or right (C) arrows to set HEADER INDEX mode. Press SELECT (D).
6. Press PROGRAM (A) to exit programming mode or press SELECT (D) to proceed to next WINDROWER SETUP action.

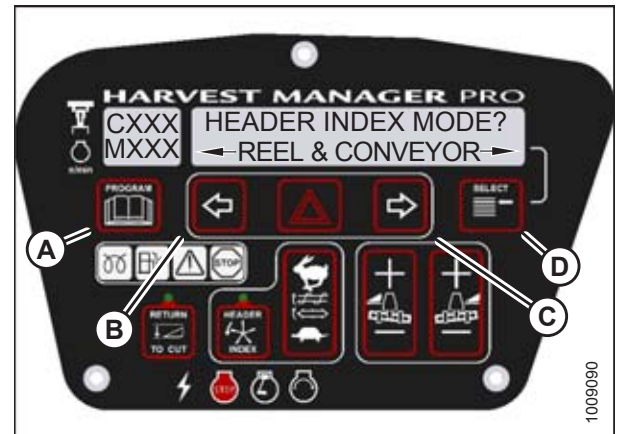

Figure 3.87: Header Index Mode

OPERATOR'S STATION

Setting the Return to Cut Mode

Return to Cut allows the Operator to resume preferred header positions and headland presets.

For more information on the Return to Cut feature, refer to [4.4.7 Return to Cut, page 211](#).

NOTE:

The header **MUST** be attached to the windrower to perform this procedure. The cab display module (CDM) automatically adjusts its programming for each header. For more information, refer to [4.5 Attaching and Detaching Headers, page 218](#).

1. Turn ignition key to RUN, or start the engine.
2. Press PROGRAM (A) and SELECT (C) on the cab display module (CDM) to enter programming mode.
 - WINDROWER SETUP? is displayed on the upper line.
 - NO/YES is displayed on the lower line.
3. Press right arrow (B) to select YES. Press SELECT (C).
 - SET KNIFE SPEED? is displayed.



Figure 3.88: CDM Programming Buttons

4. Press SELECT (D) until RETURN TO CUT MODE? is displayed on the upper line.
 - HEIGHT & TILT or HEIGHT ONLY will be displayed on the lower line.
5. Press left (B) or right (C) arrows to select RETURN TO CUT MODE. Press SELECT (D).
6. Press PROGRAM (A) to exit programming mode or press SELECT (D) to proceed to next WINDROWER SETUP action.



Figure 3.89: Return to Cut Mode

OPERATOR'S STATION

Setting the Auto Raise Height

Auto Raise Height allows the Operator to raise the header to a preset height by double-clicking the HEADER UP switch on the ground speed lever.

For more information on the Auto Raise Height feature, refer to [4.4.8 Auto Raise Height, page 214](#).

NOTE:

The header **MUST** be attached to the windrower to perform this procedure. The cab display module (CDM) automatically adjusts its programming for each header.

1. Turn ignition key to RUN, or start the engine.
2. Press PROGRAM (A) and SELECT (C) on the cab display module (CDM) to enter programming mode.
 - WINDROWER SETUP? is displayed on the upper line.
 - NO/YES is displayed on the lower line.
3. Press right arrow (B) to select YES. Press SELECT (C).
 - SET KNIFE SPEED? is displayed on the upper line.



Figure 3.90: CDM Programming Buttons

4. Press SELECT (D) until AUTO RAISE HEIGHT? is displayed on the upper line.
 - Last measurement is displayed on the lower line.

NOTE:

The auto raise height ranges from 4.0 (minimum) to 9.5 (maximum), in 0.5 increments. A setting of 10 disables the auto raise function.

5. Press left arrow (B) or right arrow (C) to change auto raise height.
6. Press PROGRAM (A) to exit programming mode or press SELECT (D) to proceed to next WINDROWER SETUP action.



Figure 3.91: Auto Raise Height

OPERATOR'S STATION

Activating the Hydraulic Center-Link

NOTE:

This procedure requires installation of the optional Hydraulic Center-Link (MD #B4650).

1. Turn ignition key to RUN, or start the engine.
2. Press PROGRAM (A) and SELECT (C) on the cab display module (CDM) to enter programming mode.
 - WINDROWER SETUP? is displayed on the upper line.
 - NO/YES is displayed on the lower line.
3. Press right arrow (B) to select YES. Press SELECT (C).
 - SET KNIFE SPEED? is displayed on the upper line.



Figure 3.92: CDM Programming Buttons

4. Press SELECT (C) until TILT CYL INSTALLED? is displayed on the upper line.
 - NO/YES is displayed on the lower line.
5. Press right arrow (B) to select YES. Press SELECT (C).
6. Press PROGRAM (A) to exit programming mode or press SELECT (C) to proceed to next WINDROWER SETUP action.



Figure 3.93: CDM Programming Buttons

OPERATOR'S STATION

Activating the Rotary Header Drive Hydraulics

NOTE:

This procedure requires installation of the optional Rotary Header Drive Hydraulics (MD #B5510).

For more information, refer to [7.3.9 R80 and R85 Rotary Header Drive Hydraulics – 4.0 m \(13 ft.\), page 464](#).

1. Turn ignition key to RUN, or start the engine.
2. Press PROGRAM (A) and SELECT (C) on the cab display module (CDM) to enter programming mode.
 - WINDROWER SETUP? is displayed on the upper line.
 - NO/YES is displayed on the lower line.
3. Press right arrow (B) to select YES. Press SELECT (C).
 - SET KNIFE SPEED? is displayed on the upper line.



Figure 3.94: CDM Programming Buttons

4. Press SELECT (C) until DISC BLK INSTALLED? is displayed on the upper line.
 - NO/YES is displayed on the lower line.
5. Press right arrow (B) to select YES. Press SELECT (C).
6. Press PROGRAM (A) to exit programming mode or press SELECT (C) to proceed to next WINDROWER SETUP action.



Figure 3.95: Rotary Disc Hydraulics

OPERATOR'S STATION

Setting the Header Cut Width

The header sends an electrical signal to the windrower to produce a header ID; however, the cut width will always default to the smallest header size available for each header type. For example, A Series Auger Headers come in 4.3, 4.9, and 5.5 m (14, 16, and 18 ft.) sizes, but the cut width will default to 4.3 m (14 ft.). Adjust setting to your specific header size.

NOTE:

- The header **MUST** be attached to the windrower to perform this procedure. The cab display module (CDM) automatically adjusts its programming for each header. For more information, refer to [4.5 Attaching and Detaching Headers, page 218](#).
 - Header cut width is set to less than the actual header width in order to accurately measure the number of acres cut.
1. Turn ignition key to RUN, or start the engine.
 2. Press PROGRAM (A) and SELECT (C) on the cab display module (CDM) to enter programming mode.
 - WINDROWER SETUP? is displayed on the upper line.
 - NO/YES is displayed on the lower line.
 3. Press right arrow (B) to select YES. Press SELECT (C).
 - SET KNIFE SPEED? is displayed.



Figure 3.96: CDM Programming Buttons

4. Press SELECT (D) until HDR CUT WIDTH? ##### is displayed on the upper line.
 - Previous cutting width is displayed on the lower line.
5. Press left (B) or right (C) arrows to change the header cut width. Press SELECT (D).
6. Press PROGRAM (A) to exit programming mode or press SELECT (D) to proceed to next WINDROWER SETUP action.

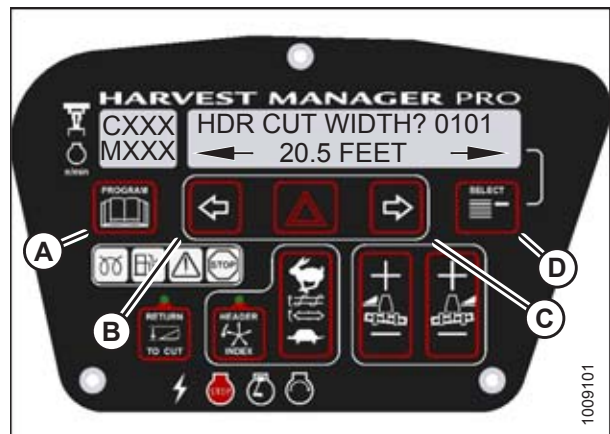

Figure 3.97: Header Cut Width

OPERATOR'S STATION

Activating the Swath Compressor

An optional swath compressor (MD #C2061) is available through your MacDon Dealer. Before using the swath compressor, you must activate it on the cab display module (CDM).

NOTE:

- CDM5 (version 512 or later) and WCM2 (version 237 or later), or WCM3 (version 116 or later), are required to operate the swath compressor.
- Users can activate and set up the swath compressor via in-cab controls without a header attached to the windrower.

Use the following procedure when installing and setting up the swath compressor:

CAUTION

Check to be sure all bystanders have cleared the area.

1. Turn ignition key to RUN, or start the engine.
2. Press PROGRAM (A) and SELECT (C) on the cab display module (CDM) to enter programming mode.
 - WINDROWER SETUP? is displayed on the upper line.
 - NO/YES is displayed on the lower line.
3. Press right arrow (B) to select YES. Press SELECT (C).
 - SET KNIFE SPEED? is displayed on the upper line.
4. Press SELECT (B) until SWATH COMPR INSTALL? is displayed on the upper line.
 - NO/YES is displayed on the lower line.
5. Press right arrow (A) to select YES. Press SELECT (B).
6. Press SELECT (B) until CALIBRATE SENSORS is displayed on upper line. NO/YES is displayed on lower line.
7. Press right arrow (A) to select YES. Press SELECT (B).
 - TO CALIBRATE SELECT is displayed on upper line.
 - HEADER HEIGHT is displayed on lower line.
8. Press right arrow (A) to scroll through choices until SWATH COMPR HT is displayed. Press SELECT (B).
 - SWATH SENSOR CAL is displayed on upper line.
 - SWATH UP TO START is displayed on lower line.

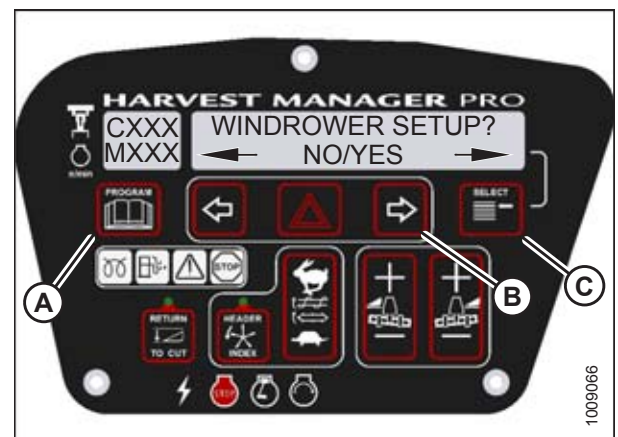

Figure 3.98: CDM Programming Buttons



Figure 3.99: Swath Compressor Controls

OPERATOR'S STATION

9. Press switch (B) on console to raise swath compressor.
 - CALIBRATING SWATH is displayed on upper line.
 - FORM UP and flashing HOLD is displayed on lower line until system has completed reading signal with swath compressor fully raised.
 - SWATH FORM UP and DONE (with buzzer) is displayed on lower line when complete.
 - SWATH SENSOR CAL is displayed on upper line.
 - PRESS SWATH DOWN is displayed on lower line.
10. Press switch (A) on console to lower swath compressor.
 - CALIBRATING SWATH is displayed on upper line.
 - FORM DOWN and HOLD is displayed on lower line.
 - SWATH FORM COMPLETE flashes for 2 seconds on lower line (with buzzer) when calibration is finished.
11. Press PROGRAM (A) to exit programming mode or press SELECT (B) to proceed to next windrower setup action.

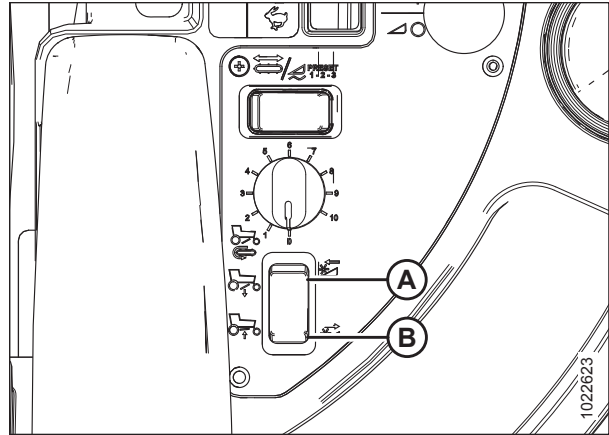

Figure 3.100: Swath Compressor Switch



Figure 3.101: CDM Programming Buttons

Activating the Hay Conditioner

NOTE:

- This procedure is for draper headers only.
- The header **MUST** be attached to the windrower to perform this procedure. The cab display module (CDM) automatically adjusts its programming for each header. For more information, refer to [4.5 Attaching and Detaching Headers, page 218](#).

1. Turn ignition key to RUN, or start the engine.
2. Press PROGRAM (A) and SELECT (C) on the cab display module (CDM) to enter programming mode.
 - WINDROWER SETUP? is displayed on the upper line.
 - NO/YES is displayed on the lower line.
3. Press right arrow (B) to select YES. Press SELECT (C).
 - SET KNIFE SPEED? is displayed on the upper line.



Figure 3.102: CDM Programming Buttons

4. Press SELECT (C) until HAY CONDITIONER? is displayed on the upper line.
 - NO/YES is displayed on the lower line.
5. Press right arrow (B) to select YES. Press SELECT (C).
6. Press PROGRAM (A) to exit programming mode or press SELECT (C) to proceed to next WINDROWER SETUP action.



Figure 3.103: Hay Conditioner Activation

OPERATOR'S STATION

Displaying Reel Speed

NOTE:

- This procedure is for draper and auger headers. It does not apply to rotary disc headers.
- The header **MUST** be attached to the windrower to perform this procedure. The cab display module (CDM) automatically adjusts its programming for each header. For more information, refer to [4.5 Attaching and Detaching Headers, page 218](#).

1. Turn ignition key to RUN, or start the engine.
2. Press PROGRAM (A) and SELECT (C) on CDM to enter programming mode.
 - WINDROWER SETUP? is displayed on the upper line.
 - NO/YES is displayed on the lower line.
3. Press right arrow (B) to select YES. Press SELECT (C).
 - SET KNIFE SPEED? is displayed on the upper line.



Figure 3.104: CDM Programming Buttons

4. Press SELECT (D) until HEADER REEL SPEED? is displayed on the upper line.
 - RPM/MPH or RPM/KPH is displayed on the lower line.
5. Press left (B) or right (C) arrow to select either IMPERIAL or METRIC units. Press SELECT (D).
6. Press PROGRAM (A) to exit programming mode or press SELECT (D) to proceed to next WINDROWER SETUP action.



Figure 3.105: Reel Speed Display

OPERATOR'S STATION

Setting the Windrower's Tire Size

1. Turn ignition key to RUN, or start the engine.
2. Press PROGRAM (A) and SELECT (C) on the cab display module (CDM) to enter programming mode.
 - WINDROWER SETUP? is displayed on the upper line.
 - NO/YES is displayed on the lower line.
3. Press right arrow (B) to select YES. Press SELECT (C).
 - SET KNIFE SPEED? is displayed on the upper line.



Figure 3.106: CDM Programming Buttons

4. Press SELECT (D) until SET TIRE SIZE? is displayed on the upper line.
 - Currently installed tire size is displayed on the lower line.

NOTE:

The following tire sizes are available:

- 18.4 x 26 TURF
 - 18.4 x 26 BAR
 - 23.1 x 26 TURF
 - 600 – 65 R28
5. Press left (B) or right (C) arrow and select tire size. Press SELECT (D).
 6. Press PROGRAM (A) to exit programming mode or press SELECT (D) to proceed to next WINDROWER SETUP action.



Figure 3.107: Tire Size

OPERATOR'S STATION

Setting the Engine Intermediate Speed Control (ISC) RPM

The Engine Intermediate Speed Control (ISC) feature provides three selectable engine speeds (1900, 2050, or 2200 rpm) for reduced load conditions. The default setting is 2200 rpm or the last selected rpm.

NOTE:

The programmed engine speed is activated when the header is engaged. For more information, refer to *Engine Intermediate Speed Control, page 164*.

The engine **MUST** be running to perform this procedure.

1. Start the engine.
2. Press PROGRAM (A) and SELECT (C) on the cab display module (CDM) to enter programming mode.
 - WINDROWER SETUP? is displayed on the upper line.
 - NO/YES is displayed on the lower line.
3. Press right arrow (B) to select YES. Press SELECT (C).
 - SET KNIFE SPEED? is displayed on the upper line.



Figure 3.108: CDM Programming Buttons

4. Press SELECT (B) until SET ENGINE ISC RPM? is displayed on the upper line.
 - NO/YES is displayed on the lower line.
5. Press right arrow (A) to select YES. Press SELECT (B).
 - PRESS HAZARD TO SET is displayed on the upper line.
 - ISC RPM #### is displayed on the lower line.



Figure 3.109: Engine ISC RPM

Table 3.3 ISC Settings

ISC and rpm			
Off ¹⁸	1	2	3
High Idle ¹⁹	2200 ²⁰	2000	1800

NOTE:

The previously selected ISC rpm will be flashing.

18. Off is always used when the header is not engaged.

19. Off does not appear as a menu selection, but is used when the header is not engaged.

20. Default setting.

OPERATOR'S STATION

- Press right arrow (C) to cycle between rpm options. Press HAZARD (B) to set.
- Press SELECT (D).
- EXIT ENGINE ISC? is displayed on the upper line.
- NO/YES is displayed on the lower line.
- Press right arrow (C) to select YES. Press SELECT (D).
- Press PROGRAM (A) to exit programming mode.



Figure 3.110: ISC RPM

Clearing Sub-Acres

The windrower has two counters for acres: one counter tracks the total number of acres harvested during the machine's lifetime, and the other counter tracks sub-acres harvested for smaller harvesting instances (instances like harvesting a particular field, or for a particular day). The total acres can't be cleared from the windrower's tracking, but the sub-acres can be cleared between smaller harvesting instances.

- With the key in the ON position, and the operator's station in cab-forward mode, press SELECT until the cab display module (CDM) displays sub-acres on the bottom line.
- Press and hold the PROGRAM (A) button on the CDM until the sub-acres are cleared.



Figure 3.111: Cab Display Module (CDM)

3.19.9 Activating Cab Display Lockouts

You can lock some header functions to prevent changes to settings. Use this feature to keep header settings constant when there are multiple Operators.

NOTE:

FUNCTION LOCKED flashes on CDM when locked header function switch is pressed.

Activating the Header Tilt Control Lockout

NOTE:

- The header **MUST** be attached to the windrower to perform this procedure. The cab display module (CDM) automatically adjusts its programming for each header. For more information, refer to [4.5 Attaching and Detaching Headers, page 218](#).
- This procedure requires installation of the optional Hydraulic Center-Link (MD #B4650).

1. Turn ignition key to RUN, or start the engine.
2. Press PROGRAM (A) and SELECT (C) on the cab display module (CDM) to enter programming mode.
 - WINDROWER SETUP? is displayed on the upper line.
 - NO/YES is displayed on the lower line.
3. Press right arrow (B) to select YES. Press SELECT (C).
 - SET KNIFE SPEED? is displayed on the upper line.

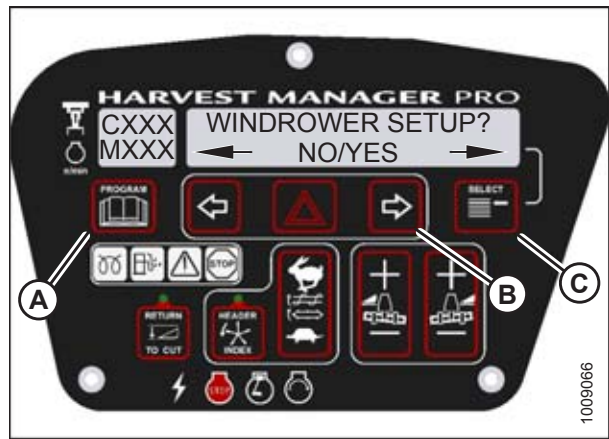

Figure 3.112: CDM Programming Buttons

4. Press SELECT (B) until SET CONTROL LOCKS? is displayed on the upper line.
 - NO/YES is displayed on the lower line.
5. Press right arrow (A) to select YES. Press SELECT (B).



Figure 3.113: Control Locks

OPERATOR'S STATION

6. Press SELECT (D) until HEADER TILT is displayed on the upper line.
 - ENABLED/LOCKED is displayed on the lower line.
7. Press left arrow (B) to enable the HEADER TILT control switch.

Press right arrow (C) to lock the HEADER TILT control switch.
8. Press PROGRAM (A) to exit programming mode, or press SELECT (D) to proceed to next WINDROWER SETUP action.



Figure 3.114: Header Tilt Control Lock

OPERATOR'S STATION

Activating the Header Float Control Lockout

NOTE:

The header **MUST** be attached to the windrower to perform this procedure. The cab display module (CDM) automatically adjusts its programming for each header.

For more information, refer to [4.5 Attaching and Detaching Headers, page 218](#).

1. Turn ignition key to RUN, or start the engine.
2. Press PROGRAM (A) and SELECT (C) on the cab display module (CDM) to enter programming mode.
 - WINDROWER SETUP? is displayed on the upper line.
 - NO/YES is displayed on the lower line.
3. Press right arrow (B) to select YES. Press SELECT (C).
 - SET KNIFE SPEED? is displayed on the upper line.



Figure 3.115: CDM Programming Buttons

4. Press SELECT (B) until SET CONTROL LOCKS? is displayed on the upper line.
 - NO/YES is displayed on the lower line.
5. Press right arrow (A) to select YES. Press SELECT (B).



Figure 3.116: Control Locks

6. Press SELECT (D) until HEADER FLOAT is displayed on the upper line.
 - ENABLED/LOCKED is displayed on the lower line.
7. Press left arrow (B) to enable HEADER FLOAT control switch, or press right arrow (C) to lock HEADER FLOAT control switch.
8. Press PROGRAM (A) to exit programming mode or press SELECT (D) to proceed to next WINDROWER SETUP action.

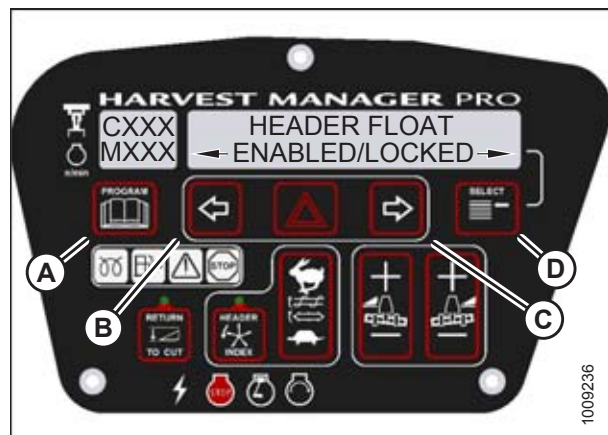

Figure 3.117: Header Float Control Lock

Activating the Reel Fore-Aft Control Lockout

NOTE:

- This procedure is for draper headers only.
- The header **MUST** be attached to the windrower to perform this procedure. The cab display module (CDM) automatically adjusts its programming for each header. For more information, refer to [4.5 Attaching and Detaching Headers, page 218](#).

1. Turn ignition key to RUN, or start the engine.
2. Press PROGRAM (A) and SELECT (C) on the cab display module (CDM) to enter programming mode.
 - WINDROWER SETUP? is displayed on the upper line.
 - NO/YES is displayed on the lower line.
3. Press right arrow (B) to select YES. Press SELECT (C).
 - SET KNIFE SPEED? is displayed on the upper line.



Figure 3.118: CDM Programming Buttons

4. Press SELECT (B) until SET CONTROL LOCKS? is displayed on the upper line.
 - NO/YES is displayed on the lower line.
5. Press right arrow (A) to select YES. Press SELECT (B).



Figure 3.119: Control Locks

OPERATOR'S STATION

6. Press SELECT (D) until REEL FORE/AFT is displayed on the upper line.
 - ENABLED/LOCKED is displayed on the lower line.
7. Press left arrow (B) to enable REEL FORE/AFT control switch.

Press right arrow (C) to lock REEL FORE/AFT control switch.
8. Press PROGRAM (A) to exit programming mode, or press SELECT (D) to proceed to next WINDROWER SETUP action.



Figure 3.120: M155 Reel Fore-Aft Control Lock

Activating the Draper Speed Control Lockout

NOTE:

- This procedure is for draper headers only.
- The header **MUST** be attached to the windrower to perform this procedure. The cab display module (CDM) automatically adjusts its programming for each header. For more information, refer to [4.5 Attaching and Detaching Headers, page 218](#).

1. Turn ignition key to RUN, or start the engine.
2. Press PROGRAM (A) and SELECT (C) on the cab display module (CDM) to enter programming mode.
 - WINDROWER SETUP? is displayed on the upper line.
 - NO/YES is displayed on the lower line.
3. Press right arrow (B) to select YES. Press SELECT (C).
 - SET KNIFE SPEED? is displayed on the upper line.



Figure 3.121: CDM Programming Buttons

4. Press SELECT (B) until SET CONTROL LOCKS? is displayed on the upper line.
 - NO/YES is displayed on the lower line.
5. Press right arrow (A) to select YES. Press SELECT (B).



Figure 3.122: Control Locks

6. Press SELECT (D) until DRAPER SPEED is displayed on the upper line.
 - ENABLED/LOCKED is displayed on the lower line.
7. Press left arrow (B) to enable DRAPER SPEED control switch, or press right arrow (C) to lock DRAPER SPEED control switch.
8. Press PROGRAM (A) to exit programming mode or press SELECT (D) to proceed to next WINDROWER SETUP action.



Figure 3.123: Draper Control Lock

OPERATOR'S STATION

Activating the Auger Speed Control Lockout

NOTE:

- This procedure is for A40D Auger Headers only.
- An auger header **MUST** be attached to the windrower to perform this procedure. The cab display module (CDM) automatically adjusts its programming for each header. For more information, refer to [4.5 Attaching and Detaching Headers, page 218](#).

1. Turn ignition key to RUN, or start the engine.
2. Press PROGRAM (A) and SELECT (C) on the cab display module (CDM) to enter programming mode.
 - WINDROWER SETUP? is displayed on the upper line.
 - NO/YES is displayed on the lower line.
3. Press right arrow (B) to select YES. Press SELECT (C).
 - SET KNIFE SPEED? is displayed on the upper line.



Figure 3.124: CDM Programming Buttons

4. Press SELECT (B) until SET CONTROL LOCKS? is displayed on the upper line.
 - NO/YES is displayed on the lower line.
5. Press right arrow (A) to select YES. Press SELECT (B).



Figure 3.125: Control Locks

6. Press SELECT (D) until AUGER SPEED is displayed on the upper line.
 - ENABLED/LOCKED is displayed on the lower line.
7. Press left arrow (B) to enable AUGER SPEED control switch. Press right arrow (C) to lock AUGER SPEED control switch.
8. Press PROGRAM (A) to exit programming mode, or press SELECT (D) to proceed to next WINDROWER SETUP action.

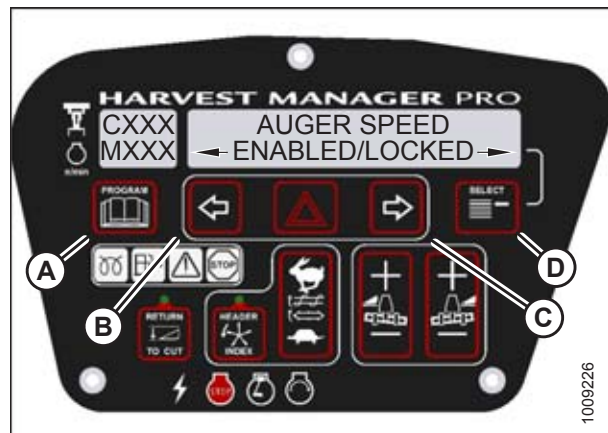

Figure 3.126: Auger Control Lock

Activating Knife Speed Control Lockout

NOTE:

The header **MUST** be attached to the windrower to perform this procedure. The cab display module (CDM) automatically adjusts its programming for each header. For more information, refer to *4.5 Attaching and Detaching Headers, page 218*.

1. Turn ignition key to RUN, or start the engine.
2. Press PROGRAM (A) and SELECT (C) on the cab display module (CDM) to enter programming mode.
 - WINDROWER SETUP? is displayed on the upper line.
 - NO/YES is displayed on the lower line.
3. Press right arrow (B) to select YES. Press SELECT (C).
 - SET KNIFE SPEED? is displayed on the upper line.



Figure 3.127: CDM Programming Buttons

4. Press SELECT (B) until SET CONTROL LOCKS? is displayed on the upper line.
 - NO/YES is displayed on the lower line.
5. Press right arrow (A) to select YES. Press SELECT (B).



Figure 3.128: Control Locks

6. Press SELECT (D) until KNIFE SPEED is displayed on the upper line.
 - ENABLED/LOCKED is displayed on the lower line.
7. Press left arrow (B) to enable KNIFE SPEED control switch, or press right arrow (C) to lock KNIFE SPEED control switch.
8. Press PROGRAM (A) to exit programming mode or press SELECT (D) to proceed to next WINDROWER SETUP action.

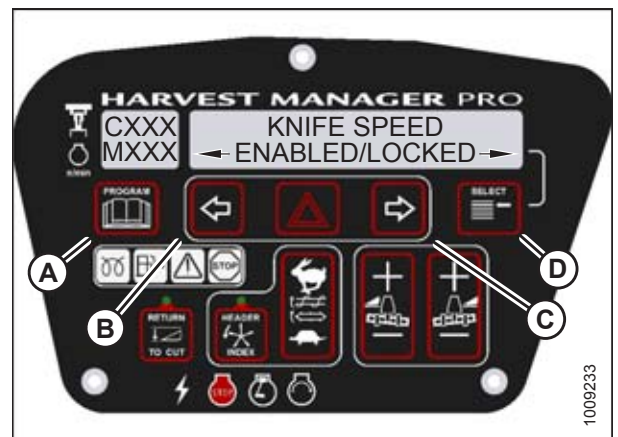

Figure 3.129: Knife Speed Control Lock

OPERATOR'S STATION

Activating Rotary Disc Speed Control Lockout

NOTE:

- This procedure is for rotary disc headers only.
- The header **MUST** be attached to the windrower to perform this procedure. The cab display module (CDM) automatically adjusts its programming for each header. For more information, refer to [4.5 Attaching and Detaching Headers, page 218](#).

1. Turn ignition key to RUN, or start the engine.
2. Press PROGRAM (A) and SELECT (C) on the cab display module (CDM) to enter programming mode.
 - WINDROWER SETUP? is displayed on the upper line.
 - NO/YES is displayed on the lower line.
3. Press right arrow (B) to select YES. Press SELECT (C).
 - SET KNIFE SPEED? is displayed on the upper line.



Figure 3.130: CDM Programming Buttons

4. Press SELECT (B) until SET CONTROL LOCKS? is displayed on the upper line.
 - NO/YES is displayed on the lower line.
5. Press right arrow (A) to select YES. Press SELECT (B).



Figure 3.131: Control Locks

6. Press SELECT (D) until DISK SPEED is displayed on the upper line.
 - ENABLED/LOCKED is displayed on the lower line.
7. Press left arrow (B) to enable DISK SPEED control switch, or press right arrow (C) to lock DISK SPEED control switch.
8. Press PROGRAM (A) to exit programming mode or press SELECT (D) to proceed to next WINDROWER SETUP action.

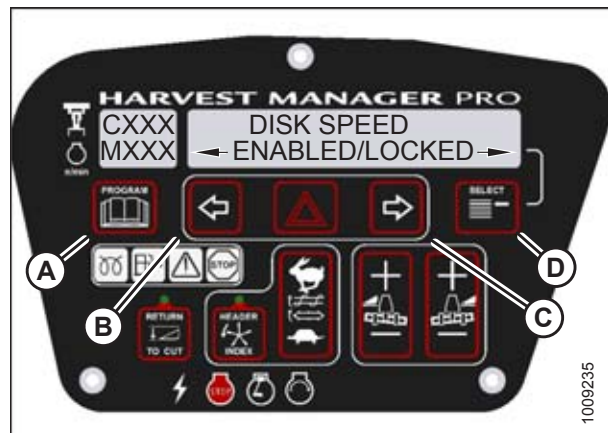

Figure 3.132: Disc Speed Control Lock

Activating the Reel Speed Control Lockout

NOTE:

This procedure is for draper headers only.

NOTE:

The header **MUST** be attached to the windrower to perform this procedure. The cab display module (CDM) automatically adjusts its programming for each header.

For more information, refer to [4.5 Attaching and Detaching Headers, page 218](#).

1. Turn the ignition key to RUN, or start the engine.
2. Press PROGRAM (A) and SELECT (C) on the cab display module (CDM) to enter programming mode.
 - WINDROWER SETUP? is displayed on the upper line.
 - NO/YES is displayed on the lower line.
3. Press right arrow (B) to select YES. Press SELECT (C).
 - SET KNIFE SPEED? is displayed on the upper line.



Figure 3.133: CDM Programming Buttons

4. Press SELECT (B) until SET CONTROL LOCKS? is displayed on the upper line.
 - NO/YES is displayed on the lower line.
5. Press right arrow (A) to select YES. Press SELECT (B).



Figure 3.134: Control Locks

OPERATOR'S STATION

6. Press SELECT (D) until REEL SPEED is displayed on the upper line.
 - ENABLED/LOCKED is displayed on the lower line.
7. Press left arrow (B) to enable the REEL SPEED control switch.

Press right arrow (C) to lock the REEL SPEED control switch.
8. Press PROGRAM (A) to exit programming mode, or press SELECT (D) to proceed to next WINDROWER SETUP action.



Figure 3.135: Reel Speed Control Lock

3.19.10 Displaying Activated Cab Display Lockouts

Displaying the activated control locks allows you to quickly determine which controls are locked on the cab display module (CDM).

NOTE:

Displaying header tilt control lock requires installation of the optional Hydraulic Center-Link (MD #B4650).

1. Turn ignition key to RUN, or start the engine.
2. Press PROGRAM (A) and SELECT (C) on the cab display module (CDM) to enter programming mode.
 - WINDROWER SETUP? is displayed on the upper line.
 - NO/YES is displayed on the lower line.
3. Press right arrow (B) to select YES. Press SELECT (C).
 - SET KNIFE SPEED? is displayed on the upper line.

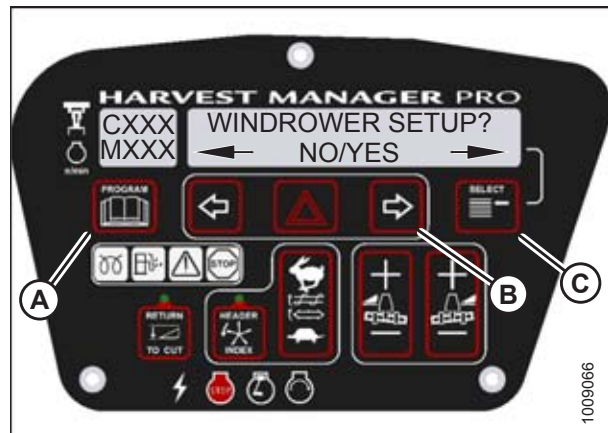

Figure 3.136: CDM Programming Buttons

4. Press SELECT (B) until VIEW CONTROL LOCKS? is displayed on the upper line.
 - NO/YES is displayed on the lower line.
5. Press right arrow (A) to select YES. Press SELECT (B).

HEADER TILT is displayed on the upper line.

 - The control switch status is displayed on the lower line. The hours displayed indicate when a switch was enabled or locked.



Figure 3.137: Control Locks

OPERATOR'S STATION

6. Press left arrow (B) or right arrow (C) to cycle between control switch lockouts. The displayed control switches are as follows:

- HEADER TILT
- HEADER FLOAT
- REEL FORE/AFT
- DRAPER SPEED
- AUGER SPEED
- KNIFE SPEED
- DISK SPEED
- REEL SPEED

NOTE:

Not all control locks apply to every header.

7. Press SELECT (D).
 - EXIT VIEW LOCKOUTS? is displayed on the upper line.
 - NO/YES is displayed on the lower line.
8. Press right (C) to select YES.
9. Press PROGRAM (A) to exit programming mode or press SELECT (D) to proceed to next WINDROWER SETUP action.



Figure 3.138: Control Locks



Figure 3.139: Control Locks

3.19.11 Calibrating the Header Sensors

Sensor calibration programs the windrower control module (WCM) with settings for the attached header.

Calibrating the Header Height Sensor

NOTE:

- The header **MUST** be attached to the windrower to perform this procedure. The cab display module (CDM) automatically adjusts its configuration for each header type. For more information, refer to [4.5 Attaching and Detaching Headers, page 218](#).
- The engine **MUST** be running to perform this procedure.

1. Start the engine.
2. Press PROGRAM (A) and SELECT (B) on cab display module (CDM) to enter programming mode.
 - WINDROWER SETUP? is displayed on the upper line.
3. Press SELECT (B) until CALIBRATE SENSORS? is displayed on the upper line.
 - NO/YES is displayed on the lower line.



Figure 3.140: CDM Programming Buttons

4. Press right arrow (B) to select YES. Press SELECT (C).
5. Press left (A) or right (B) arrow until HEADER HEIGHT is displayed on the lower line. Press SELECT (C).
 - CALIBRATING HEIGHT is displayed on the upper line.
 - RAISE HEADER HOLD is displayed on the lower line.



Figure 3.141: Header Height Calibration

CAUTION

Check to be sure all bystanders have cleared the area.

6. Press and hold the HEADER UP button (A) on the ground speed lever (GSL).
 - CALIBRATING HEIGHT is displayed on the upper line.
 - RAISE HEADER HOLD is displayed on the lower line.

NOTE:

The word HOLD will flash during calibration. RAISE HEADER DONE will display on the lower line once calibration is complete.

7. Release the HEADER UP button (A).
 - HEIGHT SENSOR CAL is displayed on the upper line.
 - PRESS LOWER HEADER is displayed on the lower line.

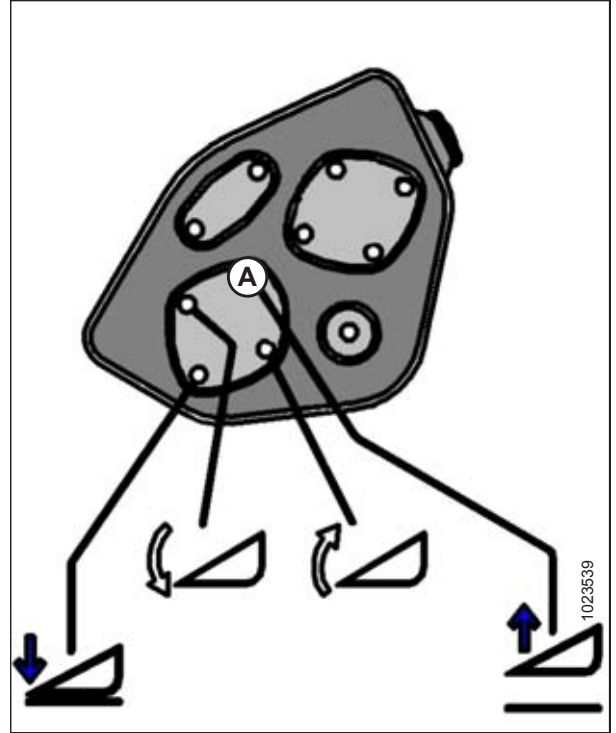

Figure 3.142: Header Height Controls on GSL

8. Press and hold HEADER DOWN button (A) on the GSL.

NOTE:

The word HOLD will flash during calibration. HT SENSOR COMPLETE will display on the lower line once calibration is complete.

9. Release HEADER DOWN button (A).
 - TO CALIBRATE SELECT is displayed on the upper line.
 - HEADER HEIGHT is displayed on the lower line.

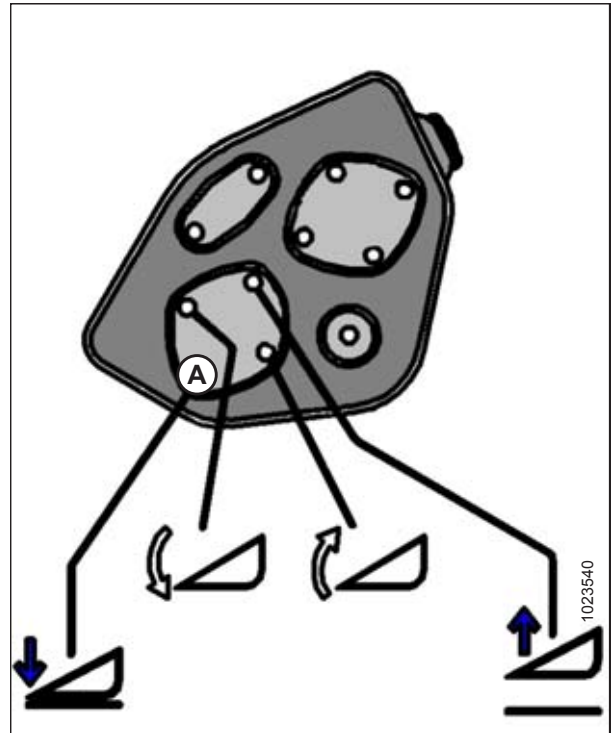

Figure 3.143: Header Height Controls on GSL

10. Press right arrow to select next header sensor calibration or STOP & EXIT. Press SELECT.

Refer to *Calibrating the Header Tilt Sensor, page 126* or *Calibrating the Header Float Sensors, page 128*.

11. Press PROGRAM to exit programming mode.

OPERATOR'S STATION

Calibrating the Header Tilt Sensor

NOTE:

- The header **MUST** be attached to the windrower to perform this procedure. The cab display module (CDM) automatically adjusts its programming for each header. Refer to *4.5 Attaching and Detaching Headers, page 218*.
- This procedure requires installation of the optional Hydraulic Center-Link (MD #B4650).
- The engine **MUST** be running to perform this procedure.

1. Start the engine.
2. Press PROGRAM (A) and SELECT (B) on cab display module (CDM) to enter programming mode.
 - WINDROWER SETUP? is displayed on the upper line.
3. Press SELECT (B) until CALIBRATE SENSORS? is displayed on the upper line.
 - NO/YES is displayed on the lower line.



Figure 3.144: CDM Programming Buttons

4. Press right arrow (B) to select YES. Press SELECT (C).
 - TO CALIBRATE SELECT is displayed in upper line.
5. Press left (A) or right (B) arrow until HEADER TILT is displayed on the lower line. Press SELECT (C).
 - HDR TILT SENSOR CAL is displayed on the upper line.
 - EXTEND TILT TO START is displayed on the lower line.



Figure 3.145: Header Tilt Calibration

CAUTION

Check to be sure all bystanders have cleared the area.

6. Press and hold the HEADER TILT EXTEND button (A) on the ground speed lever (GSL).
 - CALIBRATING TILT is displayed on the upper line.
 - EXTEND TILT HOLD is displayed on the lower line.

NOTE:

The word HOLD will flash during calibration. HEADER TILT DONE will display on the lower line once calibration is complete.

7. Release the HEADER TILT EXTEND button (A).
 - HEADER TILT SENSOR CAL is displayed on upper line.
 - PRESS RETRACT TILT is displayed on the lower line.

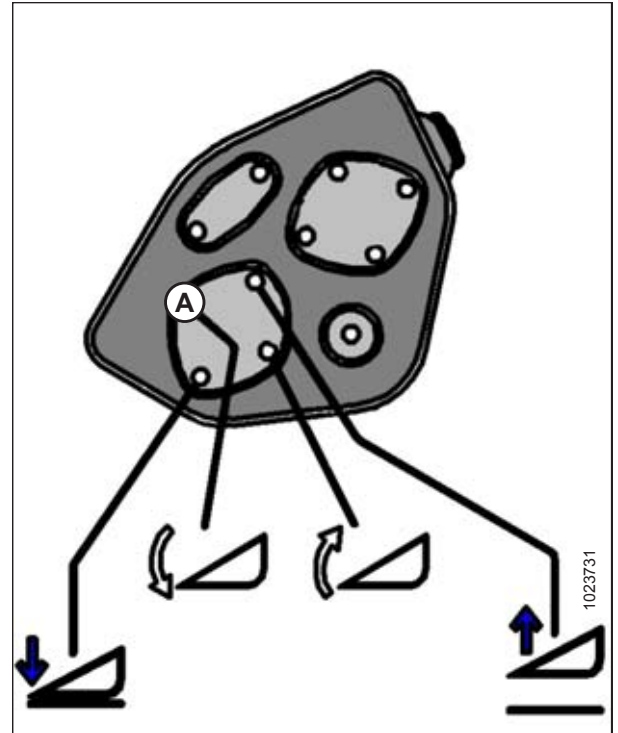

Figure 3.146: Header Tilt Controls on GSL

8. Press and hold HEADER TILT RETRACT button (A) on GSL.
 - CALIBRATING TILT is displayed on the upper line.
 - RETRACT TILT HOLD is displayed on the lower line.

NOTE:

The word HOLD will flash during calibration. HEADER TILT COMPLETE will display on the lower line once calibration is complete.

9. Release HEADER TILT RETRACT button (A).
 - TO CALIBRATE SELECT is displayed on the upper line.
 - HEADER TILT is displayed on the lower line.

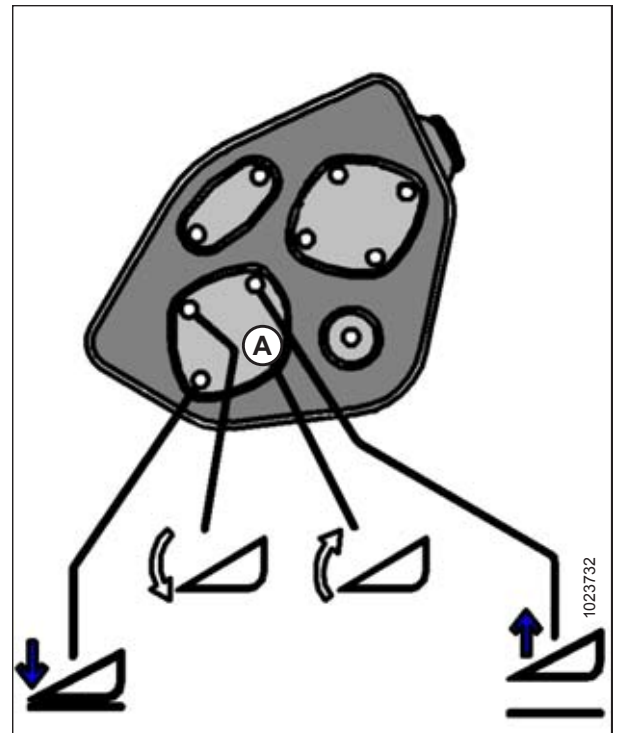

Figure 3.147: Header Tilt Controls on GSL

10. Press right arrow to select next header sensor calibration or STOP & EXIT. Press SELECT.

Refer to *Calibrating the Header Height Sensor, page 124* or *Calibrating the Header Float Sensors, page 128*.

11. Press PROGRAM to exit programming mode.

OPERATOR'S STATION

Calibrating the Header Float Sensors

NOTE:

- The header **MUST** be attached to the windrower to perform this procedure. The cab display module (CDM) automatically adjusts its programming for each header. For more information, refer to [4.5 Attaching and Detaching Headers, page 218](#).
- Use the left or right FLOAT buttons on the CDM to perform this procedure.

IMPORTANT:

Ensure float pins (A) are installed in the working position.

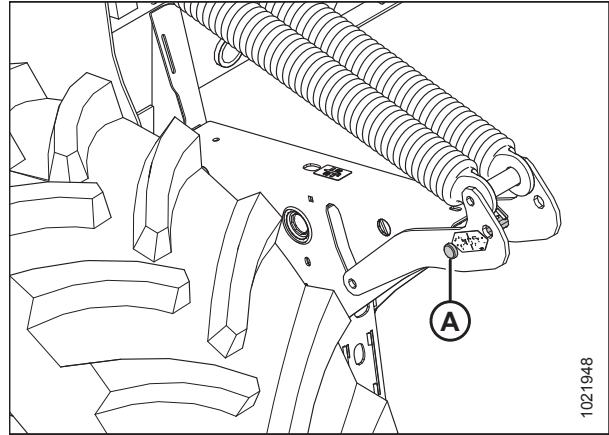

Figure 3.148: Float Pin – Right Side

1. Start the engine.
2. Press PROGRAM (A) and SELECT (B) on the cab display module to enter programming mode.
 - WINDROWER SETUP? is displayed on the upper line.
3. Press SELECT (B) until CALIBRATE SENSORS? is displayed on the upper line.
 - NO/YES is displayed on the lower line.



Figure 3.149: CDM Programming Buttons

4. Press right arrow (B) to select YES. Press SELECT (C).
 - TO CALIBRATE SELECT is displayed in upper line.
5. Press left arrow (A) or right arrow (B) until HEADER FLOAT is displayed on the lower line. Press SELECT (C).
 - CALIBRATING FLOAT is displayed on the upper line.
 - PRESS FLOAT + TO START is displayed on the lower line.



Figure 3.150: M155 Header Float Display

CAUTION

Check to be sure all bystanders have cleared the area.

6. Press and hold FLOAT + button (A) on the CDM.
 - CALIBRATING FLOAT is displayed on the upper line.
 - FLOAT (+) HOLD is displayed on the lower line.

NOTE:

The word HOLD will flash during calibration. FLOAT (+) DONE will display on the lower line once calibration is complete.

7. Release the FLOAT + button (A).
 - CALIBRATING FLOAT is displayed on the upper line.
 - FLOAT (-) HOLD is displayed on the lower line.



Figure 3.151: Positive Header Float Display

8. Press and hold FLOAT – button (A) on CDM.
 - CALIBRATING FLOAT is displayed on the upper line.
 - FLOAT (-) HOLD is displayed on the lower line.

NOTE:

The word HOLD will flash during calibration. HDR FLOAT COMPLETE will display on the lower line once calibration is complete.

9. Release FLOAT – button (A).
 - TO CALIBRATE SELECT is displayed on the upper line.
 - HEADER FLOAT is displayed on the lower line.



Figure 3.152: Negative Header Float Display

10. Press right arrow to select next header sensor calibration or STOP & EXIT. Press SELECT. Refer to *Calibrating the Header Height Sensor, page 124* or *Calibrating the Header Tilt Sensor, page 126*.
11. Press PROGRAM to exit programming mode.

3.19.12 Calibrating the Swath Compressor Sensor

This topic only applies to machines equipped with a swath compressor. To calibrate the swath compressor sensor, follow these steps:

1. Turn ignition key to RUN, or start the engine.
2. Press PROGRAM (A) and SELECT (B) on cab display module (CDM) to enter programming mode.
 - WINDROWER SETUP? is displayed on the upper line.
3. Press SELECT (B) until CALIBRATE SENSORS? is displayed on the upper line.
 - NO/YES is displayed on the lower line.



Figure 3.153: CDM Programming Buttons

4. Press right arrow (A) to select YES. Press SELECT (B).
 - TO CALIBRATE SELECT is displayed in upper line.
5. Press right arrow (A) to scroll through the choices until SWATH COMPR HT is displayed on the lower line. Press SELECT (B).
 - SWATH SENSOR CAL is displayed on the upper line.
 - SWATH UP TO START is displayed on the lower line.



Figure 3.154: Swath Compressor Sensor Calibration

6. Press and hold button (B) to raise the swath compressor.
 - CALIBRATING SWATH is displayed on the upper line.
 - FORM UP and flashing HOLD is displayed on the lower line until the system has completed reading signal with swath compressor fully raised.
 - SWATH FORM UP DONE (with buzzer) is displayed on the lower line when complete.

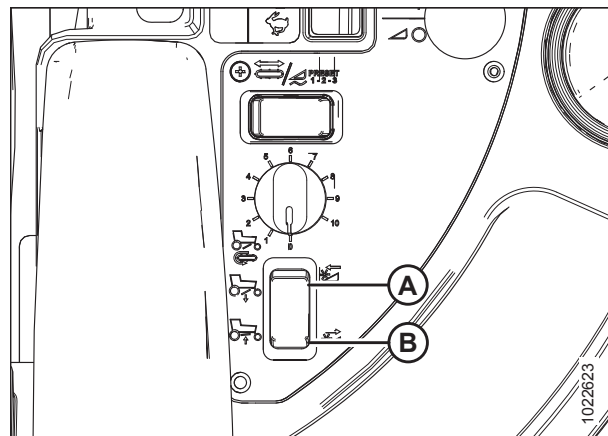

Figure 3.155: Swath Compressor Controls

- A - Lower Swath Compressor
- B - Raise Swath Compressor

OPERATOR'S STATION

- SWATH SENSOR CAL is displayed on the upper line.
- PRESS SWATH DOWN is displayed on the lower line.



Figure 3.156: Swath Compressor Sensor Calibration

7. Press and hold button (A) to lower the swath compressor.
 - CALIBRATING SWATH is displayed on the upper line.
 - FORM DOWN and flashing HOLD is displayed on the lower line.
 - SWATH FORM COMPLETE flashes for 2 seconds on the lower line (with buzzer) when the calibration is complete.
8. Press PROGRAM to exit programming mode.

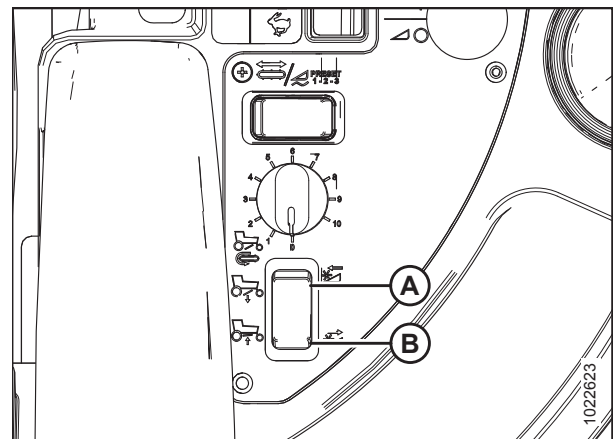

Figure 3.157: Swath Compressor Controls

- A - Lower Swath Compressor
- B - Raise Swath Compressor

3.19.13 Troubleshooting Windrower Problems

Displaying the Windrower and Engine Error Codes

1. Turn ignition key to RUN, or start the engine.
2. Press PROGRAM (A) and SELECT (B) on cab display module (CDM) to enter programming mode. Press SELECT (B).
 - WINDROWER SETUP? is displayed on the upper line.
3. Press SELECT (B) until DIAGNOSTIC MODE? is displayed in upper line.
 - NO/YES is displayed on the lower line.



Figure 3.158: CDM Programming Buttons

OPERATOR'S STATION

4. Press right arrow (A) to select YES. Press SELECT (B).
5. VIEW ERROR CODES? is displayed on the upper line.
 - NO/YES is displayed on the lower line.
6. Press right arrow (A) to select YES. Press SELECT (B).
 - VIEW WINDRWR CODES? is displayed on the upper line.
 - NO/YES is displayed on the lower line.



Figure 3.159: Diagnostic Functions

7. Press right arrow (A) to select YES. Press SELECT (C).
 - The most recent error code will be displayed.
 - Refer to [8.5 Cab Display Module Error Codes, page 494](#).
8. Press right (A) or left (B) arrow to cycle through the last ten recorded windrower error codes until EXIT WINDROWER CODES is displayed.
9. Press right arrow (A) to select YES. Press SELECT (C).
 - VIEW ENGINE CODES is displayed on the upper line.
 - NO/YES is displayed on the lower line.

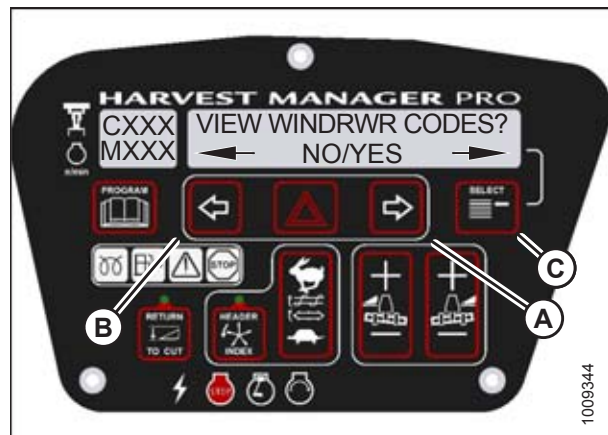

Figure 3.160: Windrower Codes

10. Press right arrow (C) to select YES. Press SELECT (D).
11. Press left (B) or right (C) arrow to cycle through the last ten recorded engine error codes until EXIT ENGINE CODES is displayed.
 - Refer to [8.4 Engine Error Codes, page 482](#).
12. Press right arrow (C) to select YES. Press SELECT (D).
13. Press PROGRAM (A) to exit programming mode or press SELECT (D) to proceed to next diagnostic mode.

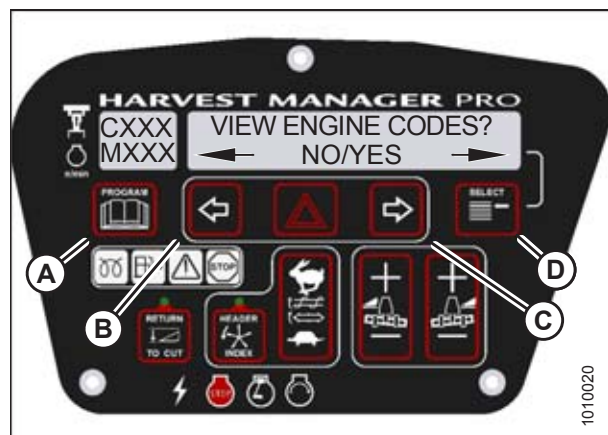

Figure 3.161: Engine Codes

Switching the Installed Header Sensors ON or OFF

You can selectively enable or disable header sensors in the event of a malfunction or as part of a troubleshooting routine.

NOTE:

- The header **MUST** be attached to the windrower to perform this procedure. The cab display module (CDM) automatically adjusts its programming for each header. For more information, refer to [4.5 Attaching and Detaching Headers, page 218](#).
- Disabled sensors flash the word SENSOR on the CDM during regular operation.

1. Turn ignition key to RUN, or start the engine.
2. Press PROGRAM (A) and SELECT (C) on the cab display module (CDM) to enter programming mode.
 - WINDROWER SETUP? is displayed on the upper line.
 - NO/YES is displayed on the lower line.
3. Press SELECT (C) until DIAGNOSTIC MODE? is displayed on the upper line.
 - NO/YES is displayed on the lower line.
4. Press right arrow (B) to select YES. Press SELECT (C).
 - VIEW ERROR CODES? is displayed on the upper line.
5. Press SELECT (B) until ENTER SENSOR SETUP? is displayed on the upper line.
 - NO/YES is displayed on the lower line.
6. Press right arrow (A) to select YES. Press SELECT (B).
 - KNIFE SPEED SENSOR is displayed on the lower line.
 - ENABLE/DISABLE is displayed on the lower line.



Figure 3.162: CDM Programming Buttons



Figure 3.163: Diagnostic Functions

OPERATOR'S STATION

7. Press left arrow (B) to enable a sensor. Press right arrow (C) to disable sensor. Press SELECT (D) to confirm selection and move on to next sensor.

The following sensors are available:

- HEADER HT SENSOR
- HEADER TILT SENSOR
- KNIFE SPEED SENSOR
- REEL SPEED SENSOR
- HEADER FLOAT SENSOR
- OVERLOAD PRESSURE²¹
- HYD OIL TEMP SENSOR

When sensors have been modified, press SELECT (D) to display the EXIT SENSOR SETUP? selection.

8. Press right arrow (C) to select YES. Press SELECT.
9. Press PROGRAM (A) to exit programming mode or press SELECT to proceed to next diagnostic mode.



Figure 3.164: Header Sensors

21. Requires installation of optional pressure sensor (MD #B5574).

Displaying Header Sensor Input Signals

You can display individual sensor input signals in the event of a malfunction or as part of a troubleshooting routine.

NOTE:

The header **MUST** be attached to the windrower to perform this procedure. The cab display module (CDM) automatically adjusts its programming for each header. For more information, refer to [4.5 Attaching and Detaching Headers](#), page 218.

1. Turn the ignition key to RUN, or start the engine.
2. Press PROGRAM (A) and SELECT (B) on CDM to enter programming mode.
 - WINDROWER SETUP? is displayed on the upper line.
 - NO/YES is displayed on the lower line.



Figure 3.165: CDM Programming Buttons

3. Press SELECT (B) until DIAGNOSTIC MODE? is displayed on the upper line.
 - NO/YES is displayed on the lower line.
4. Press right arrow (A) to select YES. Press SELECT (B).
 - VIEW ERROR CODES? is displayed on the upper line.
5. Press SELECT (B) until READ SENSOR SETUP? is displayed on the upper line.
 - NO/YES is displayed on the lower line.



Figure 3.166: Diagnostic Functions

6. Press right arrow (C) to select YES. Press SELECT (D).
 - SENSOR INPUT is displayed on the upper line.
 - HDR HEIGHT 1.23 V is displayed on the lower line.
7. Press left (B) or right (C) arrow to cycle between individual sensor readers.
8. Press SELECT (D) to skip to EXIT READ SENSORS? selection.
9. Press right arrow (C) to select YES. Press SELECT.
10. Press PROGRAM (A) to exit programming mode or press SELECT (D) to proceed to next diagnostic mode.



Figure 3.167: Header Sensors

OPERATOR'S STATION

Forcing a Header ID

The header must be attached to the windrower to troubleshoot certain issues. If damage has occurred to the header wiring or no header is available, you can force the windrower control module (WCM) to read a header ID. The WCM reverts to reading NO HEADER each time the engine ignition is cycled.

IMPORTANT:

Forcing a header ID that is different from the attached header can damage the windrower and header. Doing so can lead to vibration, belt failures, and other overspeeding related problems.

1. Turn the ignition key to RUN, or start the engine.
2. Press PROGRAM (A) and SELECT (B) on CDM to enter programming mode.
 - WINDROWER SETUP? is displayed on the upper line.



Figure 3.168: CDM Programming Buttons

3. Press SELECT (B) until DIAGNOSTIC MODE? is displayed in upper line.
 - NO/YES is displayed on the lower line.
4. Press right arrow (A) to select YES. Press SELECT (B).



Figure 3.169: Diagnostic Functions

OPERATOR'S STATION

5. Press SELECT (B) until FORCE HEADER TYPE? is displayed on the upper line.
 - NO/YES is displayed on the lower line.
6. Press right arrow (A) to select YES. Press SELECT (B).
 - SELECT HEADER TYPE is displayed on the upper line.
 - DISK HEADER is displayed on the lower line.



Figure 3.170: Header Type

7. Press left (A) or right (B) arrow to cycle through list of header types.
8. When desired header type is displayed, press SELECT (C).
 - EXIT FORCE HEADER? is displayed on the upper line.
 - NO/YES is displayed on the lower line.
9. Press right arrow (B) to select YES. Press SELECT (C).

Proceed to next diagnostic mode, or press PROGRAM to exit programming mode.



Figure 3.171: Header Type

3.19.14 Troubleshooting Header Problems

You can test individual parts of the header as part of a troubleshooting routine.

Testing the Header Up/Down Activate Function Using the Cab Display Module

NOTE:

- The header **MUST** be attached to the windrower to perform this procedure. The cab display module (CDM) automatically adjusts its programming for each header. For more information, refer to [4.5 Attaching and Detaching Headers, page 218](#).

- The engine **MUST** be running to perform this procedure.

1. Start the engine.
2. Press PROGRAM (A) and SELECT (B) on CDM to enter programming mode. Press SELECT (B).

- WINDROWER SETUP? is displayed on the upper line.



Figure 3.172: CDM Programming Buttons

3. Press SELECT (B) until DIAGNOSTIC MODE? is displayed in upper line.

- NO/YES is displayed on the lower line.

4. Press right arrow (A) to select YES. Press SELECT (B).



Figure 3.173: Diagnostic Functions

OPERATOR'S STATION

5. Press SELECT (B) until ACTIVATE FUNCTIONS? is displayed on the upper line.
 - NO/YES is displayed on the lower line.
6. Press right arrow (A) to select YES. Press SELECT (B).

CAUTION

Check to be sure all bystanders have cleared the area.



Figure 3.174: Functions

7. Press SELECT (D) until ACTIVATE HEADER HT is displayed on the upper line.
 - DOWN/UP is displayed on the lower line.
8. Press and hold left arrow (B) to lower header, or press and hold right arrow (C) to raise header. Verify header is functioning properly.
9. Press PROGRAM (A) to exit programming mode or press SELECT (D) to proceed to next ACTIVATE FUNCTION.



Figure 3.175: Header Height

OPERATOR'S STATION

Testing the Reel Up/Down Activate Function Using the Cab Display Module

NOTE:

- This procedure is for draper headers only.
- The header **MUST** be attached to the windrower to perform this procedure. The cab display module (CDM) automatically adjusts its programming for each header. For more information, refer to [4.5 Attaching and Detaching Headers, page 218](#).

1. Turn ignition key to RUN, or start the engine.
2. Press PROGRAM (A) and SELECT (B) on the CDM to enter programming mode. Press SELECT (B).
 - WINDROWER SETUP? is displayed on the upper line.



Figure 3.176: M155 CDM Programming Buttons

3. Press SELECT (B) until DIAGNOSTIC MODE? is displayed in upper line.
 - NO/YES is displayed on the lower line.
4. Press right arrow (A) to select YES. Press SELECT (B).



Figure 3.177: Diagnostic Functions

5. Press SELECT (B) until ACTIVATE FUNCTIONS? is displayed on the upper line.
 - NO/YES is displayed on the lower line.
6. Press right arrow (A) to select YES. Press SELECT (B).



Figure 3.178: Functions

OPERATOR'S STATION

- Press SELECT (D) until ACTIVATE REEL HT is displayed on the upper line.
 - DOWN/UP is displayed on the lower line.

CAUTION

Check to be sure all bystanders have cleared the area.

- Press and hold left arrow (B) to lower reel. Press and hold right arrow (C) to raise reel.

IMPORTANT:

Verify reel is functioning properly.

- Press PROGRAM (A) to exit programming mode or press SELECT (D) to proceed to next ACTIVATE FUNCTION.



Figure 3.179: Reel Height

Testing the Header Tilt Activate Function Using the Cab Display Module

NOTE:

- The header **MUST** be attached to the windrower to perform this procedure. The cab display module (CDM) automatically adjusts its programming for each header. For more information, refer to [4.5 Attaching and Detaching Headers, page 218](#).
 - This procedure requires installation of the optional Hydraulic Center-Link (MD #B4650).
 - The engine **MUST** be running to perform this procedure.
- Start the engine.
 - Press PROGRAM (A) and SELECT (B) on the CDM to enter programming mode.
 - WINDROWER SETUP? is displayed on the upper line.



Figure 3.180: CDM Programming Buttons

OPERATOR'S STATION

3. Press SELECT (B) until DIAGNOSTIC MODE? is displayed in upper line.
 - NO/YES is displayed on the lower line.
4. Press right arrow (A) to select YES. Press SELECT (B).

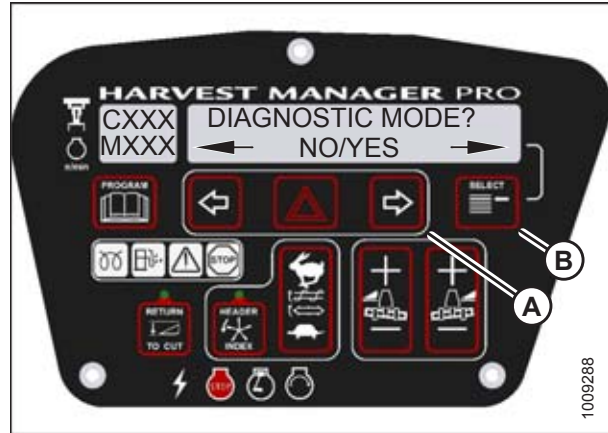

Figure 3.181: Diagnostic Functions

5. Press SELECT (B) until ACTIVATE FUNCTIONS? is displayed on the upper line.
 - NO/YES is displayed on the lower line.
6. Press right arrow (A) to select YES. Press SELECT (B).



Figure 3.182: Functions

7. Press SELECT (D) until ACTIVATE HDR TILT is displayed on the upper line.
 - IN/OUT is displayed on the lower line.
8. Press and hold left arrow (B) to **decrease** header tilt. Press and hold right arrow (C) to **increase** header tilt.

IMPORTANT:

Verify header is functioning properly.

9. Press PROGRAM (A) to exit programming mode or press SELECT (D) to proceed to next ACTIVATE FUNCTION.



Figure 3.183: Header Tilt Angle

OPERATOR'S STATION

Testing the Knife Drive Circuit Using the Cab Display Module

IMPORTANT:

Do **NOT** overspeed a drive. Overspeeding can lead to vibration, belt failures, or other overspeeding related problems.

NOTE:

- The header **MUST** be attached to windrower to follow this procedure. For more information, refer to [4.5 Attaching and Detaching Headers, page 218](#).
 - The engine **MUST** be running to perform this procedure.
1. Start the engine.
 2. Press PROGRAM (A) and SELECT (B) on cab display module (CDM) to enter programming mode. Press SELECT (B).
 - WINDROWER SETUP? is displayed on the upper line.



Figure 3.184: CDM Programming Buttons

3. Press SELECT (B) until DIAGNOSTIC MODE? is displayed in upper line.
 - NO/YES is displayed on the lower line.
4. Press right arrow (A) to select YES. Press SELECT (B).



Figure 3.185: Diagnostic Functions

OPERATOR'S STATION

5. Press SELECT (B) until ACTIVATE FUNCTIONS? is displayed on the upper line.
 - NO/YES is displayed on the lower line.
6. Press right arrow (A) to select YES. Press SELECT (B).
 - ACTIVATE HEADER HT is displayed on the upper line.



Figure 3.186: Functions

CAUTION

Check to be sure all bystanders have cleared the area.

7. Press SELECT (E) until KNIFE DRIVE SPD XXXX is displayed on the upper line.

IMPORTANT:

Do **NOT** overspeed the knife drive.

8. Press and hold HAZARD (C) button.
 - Press left arrow (B) to decrease knife speed.
 - Press right arrow (D) to increase knife speed.

IMPORTANT:

Verify the knife drive is functioning properly.

9. Release the HAZARD (C) button. The knife will stop.
10. Press PROGRAM (A) to exit programming mode or press SELECT (E) to proceed to next ACTIVATE FUNCTION.

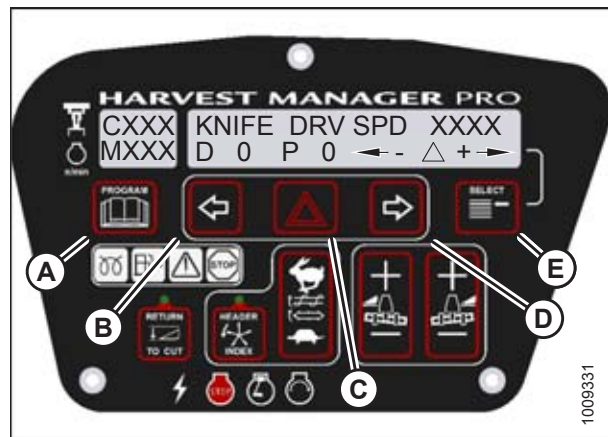

Figure 3.187: Knife Drive

OPERATOR'S STATION

Testing the Draper Drive Circuit Activate Function Using the Cab Display Module

IMPORTANT:

Do **NOT** overspeed a drive. Overspeeding can lead to vibration, belt failures, or other overspeeding related problems.

NOTE:

- A draper header **MUST** be attached to windrower to follow this procedure. For more information, refer to [4.5 Attaching and Detaching Headers, page 218](#).
 - The engine **MUST** be running to perform this procedure.
1. Start the engine.
 2. Press PROGRAM (A) and SELECT (B) on cab display module (CDM) to enter programming mode.
 - WINDROWER SETUP? is displayed on the upper line.



Figure 3.188: CDM Programming Buttons

3. Press SELECT (B) until DIAGNOSTIC MODE? is displayed in upper line.
 - NO/YES is displayed on the lower line.
4. Press right arrow (A) to select YES. Press SELECT (B).



Figure 3.189: Diagnostic Functions

OPERATOR'S STATION

5. Press SELECT (B) until ACTIVATE FUNCTIONS? is displayed on the upper line.
 - NO/YES is displayed on the lower line.
6. Press right arrow (A) to select YES. Press SELECT (B).
 - ACTIVATE HEADER HT is displayed on the upper line.



Figure 3.190: M155 Functions

CAUTION

Check to be sure all bystanders have cleared the area.

7. Press SELECT (E) until DRAPER DRV SPD XXXX is displayed on the upper line.

IMPORTANT:

Do **NOT** overspeed the drapers.

8. Press and hold HAZARD (C) button.
 - Press left arrow (B) to decrease draper speed.
 - Press right arrow (D) to increase draper speed.

IMPORTANT:

Verify the draper drive is functioning properly.

9. Release the HAZARD (C) button. The drapers will stop.
10. Press PROGRAM (A) to exit programming mode or press SELECT (E) to proceed to next ACTIVATE FUNCTION.

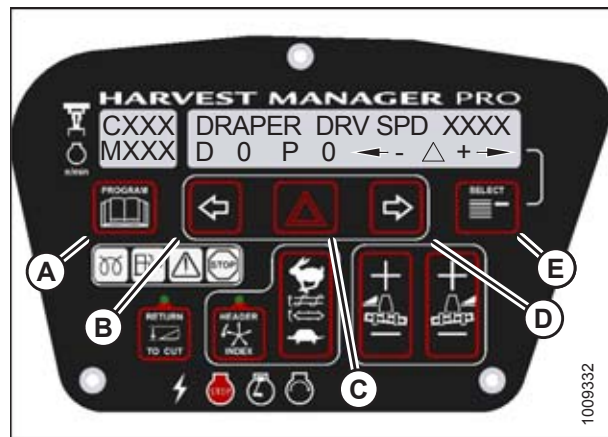

Figure 3.191: Draper Drive

OPERATOR'S STATION

Testing the Reel Drive Circuit Activate Function Using the Cab Display Module

IMPORTANT:

Do **NOT** overspeed a drive. Overspeeding can lead to vibration, belt failures, or other overspeeding related problems.

NOTE:

- The header **MUST** be attached to the windrower to follow this procedure. For more information, refer to [4.5 Attaching and Detaching Headers](#), page 218.
 - This procedure does not apply to rotary disc headers.
 - The engine **MUST** be running to perform this procedure.
1. Start the engine.
 2. Press PROGRAM (A) and SELECT (B) on cab display module (CDM) to enter programming mode.
 - WINDROWER SETUP? is displayed on the upper line.



Figure 3.192: CDM Programming Buttons

3. Press SELECT (B) until DIAGNOSTIC MODE? is displayed in upper line.
 - NO/YES is displayed on the lower line.
4. Press right arrow (A) to select YES. Press SELECT (B).



Figure 3.193: Diagnostic Functions

OPERATOR'S STATION

5. Press SELECT (B) until ACTIVATE FUNCTIONS? is displayed on the upper line.
 - NO/YES is displayed on the lower line.
6. Press right arrow (A) to select YES. Press SELECT (B).
 - ACTIVATE HEADER HT is displayed on the upper line.



Figure 3.194: Functions

CAUTION

Check to be sure all bystanders have cleared the area.

7. Press SELECT (E) until REEL DRV SPD XXXX is displayed on the upper line.

IMPORTANT:

Do **NOT** overspeed the reel.

8. Press and hold HAZARD (C) button.
 - Press left arrow (B) to decrease reel speed.
 - Press right arrow (D) to increase reel speed.

IMPORTANT:

Verify the reel drive is functioning properly.

9. Release HAZARD (C) button. The reel will stop.
10. Press PROGRAM (A) to exit programming mode or press SELECT (E) to proceed to next ACTIVATE FUNCTION.

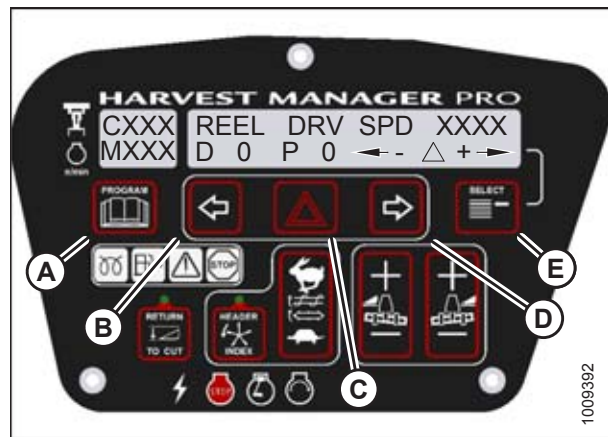

Figure 3.195: Reel Drive

OPERATOR'S STATION

Testing the Rotary Disc Drive Circuit Activate Function Using the Cab Display Module

IMPORTANT:

Do **NOT** overspeed a drive. Overspeeding can lead to vibration, belt failures, or other overspeeding related problems.

NOTE:

- A rotary disc header **MUST** be attached to windrower to follow this procedure.
 - The engine **MUST** be running to perform this procedure.
1. Start the engine.
 2. Press PROGRAM (A) and SELECT (B) on cab display module (CDM) to enter programming mode.
 - WINDROWER SETUP? is displayed on the upper line.



Figure 3.196: CDM Programming Buttons

3. Press SELECT (B) until DIAGNOSTIC MODE? is displayed on upper line.
 - NO/YES is displayed on the lower line.
4. Press right arrow (A) to select YES. Press SELECT (B).



Figure 3.197: Diagnostic Functions

OPERATOR'S STATION

5. Press SELECT (B) until ACTIVATE FUNCTIONS? is displayed on the upper line.
 - NO/YES is displayed on the lower line.
6. Press right arrow (A) to select YES. Press SELECT (B).
 - ACTIVATE HEADER HT is displayed on the upper line.



Figure 3.198: Functions

CAUTION

Check to be sure all bystanders have cleared the area.

7. Press SELECT (E) until DISC DRV SPD XXXX is displayed on the upper line.

IMPORTANT:

Do **NOT** overspeed the disc drive.

8. Press and hold HAZARD (C) button.
 - Press left arrow (B) to decrease disc speed.
 - Press right arrow (D) to increase disc speed.

IMPORTANT:

Verify the disc drive is functioning properly.

9. Release HAZARD (C) button. The disc drive will stop.
10. Press PROGRAM (A) to exit programming mode or press SELECT to proceed to next ACTIVATE FUNCTION.

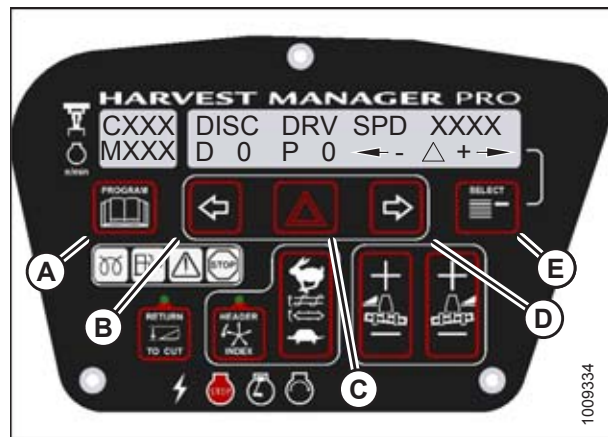

Figure 3.199: Disc Drive

OPERATOR'S STATION

Testing the Reel Fore-Aft Activate Function Using the Cab Display Module

NOTE:

- The header **MUST** be attached to windrower to perform this procedure. For more information, refer to [4.5 Attaching and Detaching Headers, page 218](#).
 - The engine **MUST** be running to perform this procedure.
1. Start the engine.
 2. Press PROGRAM (A) and SELECT (B) on cab display module (CDM) to enter programming mode.
 - WINDROWER SETUP? is displayed on the upper line.



Figure 3.200: CDM Programming Buttons

3. Press SELECT (B) until DIAGNOSTIC MODE? is displayed in upper line.
 - NO/YES is displayed on the lower line.
4. Press right arrow (A) to select YES. Press SELECT (B).



Figure 3.201: Diagnostic Functions

5. Press SELECT (B) until ACTIVATE FUNCTIONS? is displayed on the upper line.
 - NO/YES is displayed on the lower line.
6. Press right arrow (A) to select YES. Press SELECT (B).

CAUTION

Check to be sure all bystanders have cleared the area.



Figure 3.202: Functions

OPERATOR'S STATION

7. Press SELECT (D) until ACTIVATE REEL F/A is displayed on the upper line.
 - FORE/AFT is displayed on the lower line.
8. Verify reel fore-aft is functioning properly.
 - a. Press and hold left arrow (B) to move reel forward. Press and hold right arrow (C) to move reel backward.
 - b. Press PROGRAM (A) to exit programming mode or press SELECT (D) to proceed to next ACTIVATE FUNCTION.



Figure 3.203: Reel Fore-Aft

Activating the Hydraulic Purge Using the Cab Display Module

The hydraulic purge removes air from the hydraulic pump system after it has been repaired or changed.

NOTE:

Engine **MUST** be running to perform this procedure.

1. Start the engine.
2. Press PROGRAM (A) and SELECT (B) on cab display module (CDM) to enter programming mode.
 - WINDROWER SETUP? is displayed on the upper line.



Figure 3.204: CDM Programming Buttons

3. Press SELECT (B) until DIAGNOSTIC MODE? is displayed in upper line.
 - NO/YES is displayed on the lower line.
4. Press right arrow (A) to select YES. Press SELECT (B).



Figure 3.205: Diagnostic Functions

OPERATOR'S STATION

5. Press SELECT (B) until ACTIVATE FUNCTIONS? is displayed on the upper line.
 - NO/YES is displayed on the lower line.
6. Press right arrow (A) to select YES. Press SELECT (B).
 - ACTIVATE HEADER HT is displayed on the upper line.
 - DOWN/UP is displayed on the lower line.



Figure 3.206: Functions

7. Press SELECT (B) until ACTIVATE HYD PURGE? is displayed on the upper line.
 - NO/YES is displayed on the lower line.
8. Press right arrow (A) to select YES. Press SELECT (B).
 - TO ACTIVATE PURGE is displayed on the upper line.
 - PRESS AND HOLD is displayed on the lower line.

NOTE:

Holding the right arrow (A) activates a timed purge cycle. The CDM will jump to the exit menu if the arrow is released before the end of the timed cycle.

CAUTION

Check to be sure all bystanders have cleared the area.

9. Press and hold right arrow (A) to activate purge cycle.
 - PURGE CYCLE STARTED will display on the upper line.
10. When PURGE CYCLE ENDED is displayed release right arrow (A).
 - NO EXIT YES is displayed on the lower line.
11. Press right arrow to select YES. Press SELECT.
12. Press PROGRAM to exit programming mode or press SELECT to proceed to next ACTIVATE FUNCTION.



Figure 3.207: Hydraulic Purge



Figure 3.208: Hydraulic Purge Cycle

3.19.15 Engine Error Codes

To assist the Operator or Technician in locating a specific problem with engine operation, the cab display module (CDM) displays error codes when there is a fault with one of the several sensors that monitor and control engine operation. For an explanation of an engine error code, refer to [8.4 Engine Error Codes, page 482](#).

3.19.16 Cab Display Module and Windrower Control Module Fault Codes

To assist the Operator or Technician in locating a specific problem with the windrower, the cab display module (CDM) displays fault codes when there is a fault with one of the sensors that monitor and control windrower operation. For an explanation of fault code, refer to [8.5 Cab Display Module Error Codes, page 494](#).

Chapter 4: Operation

4.1 Owner/Operator Responsibilities



CAUTION

- It is your responsibility to read and understand this manual completely before operating the windrower. Contact your Dealer if an instruction is not clear to you.
- Follow all safety messages in the manual and on safety signs on the machine.
- Remember that YOU are the key to safety. Good safety practices protect you and the people around you.
- Before allowing anyone to operate the windrower, for however short a time or distance, make sure they have been instructed in its safe and proper use.
- Review the manual and all safety related items with all Operators every year.
- Be alert for other Operators not using recommended procedures or not following safety precautions. Correct these mistakes immediately, before an accident occurs.
- Do NOT modify the machine. Unauthorized modifications may impair the function and/or safety and affect machine life.
- The safety information given in this manual does NOT replace safety codes, insurance needs, or laws governing your area. Be sure your machine meets the standards set by these regulations.

4.2 Symbol Definitions

The following symbols are used to depict functions or reactions of the various instruments and controls.

Learn the meaning of these symbols before operating the windrower.

4.2.1 Engine Functions

These are the symbols that are used on the console:

Figure 4.1: Engine Function Symbols

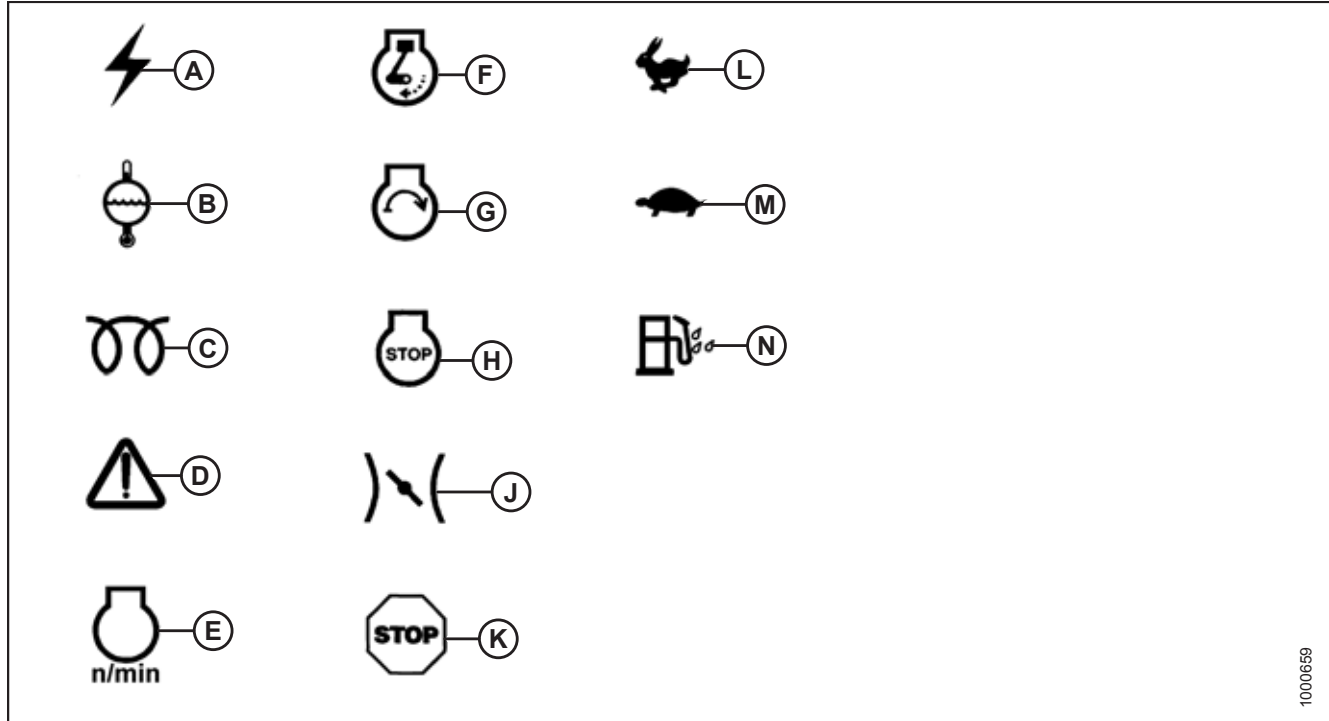

A - Electrical Power – Accessories

D - Engine Malfunction

G - Engine Start

K - Engine Urgent Stop

N - Water in Fuel

B - Engine Coolant Temperature

E - Engine rpm

H - Engine Stop

L - Fast

C - Engine Glow Plugs

F - Engine Run

J - Engine Throttle

M - Slow

1000659

4.2.2 Windrower Operating Symbols

These are the symbols used on the console for windrower operation:

Figure 4.2: Windrower Operating Symbols

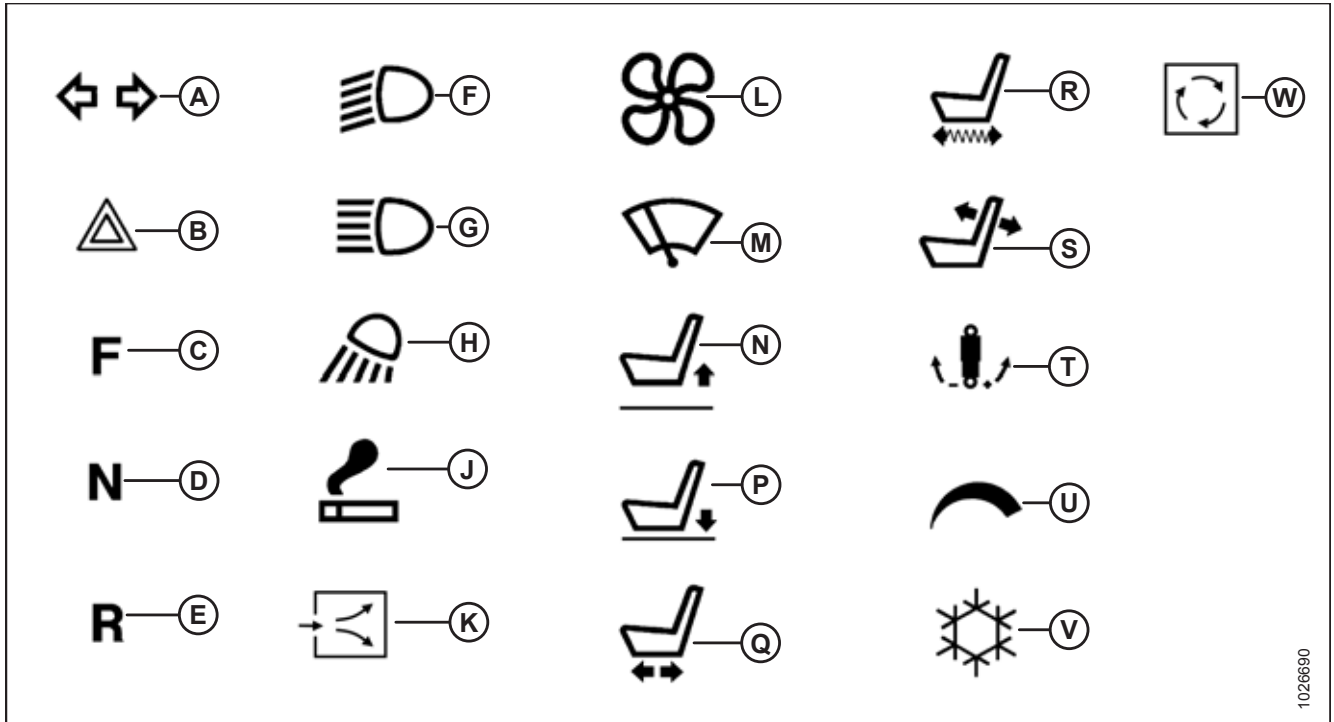

A - Turn Signals

D - Neutral

G - Headlights High Beam

K - Fresh Air

N - Seat Height Up

R - Seat Fore Aft Isolator

U - Cab Temperature Control

B - Hazard Warning Lights

E - Reverse

H - Work Light

L - Blower

P - Seat Height Down

S - Seat Back Fore and Aft

V - Air Conditioning

C - Forward

F - Headlights Low Beam

J - Lighter

M - Windshield Wiper

Q - Seat Fore and Aft

T - Seat Ride Damping

W - Recirculate

4.2.3 Header Functions

These are the symbols used on the console:

Figure 4.3: Header Function Symbols

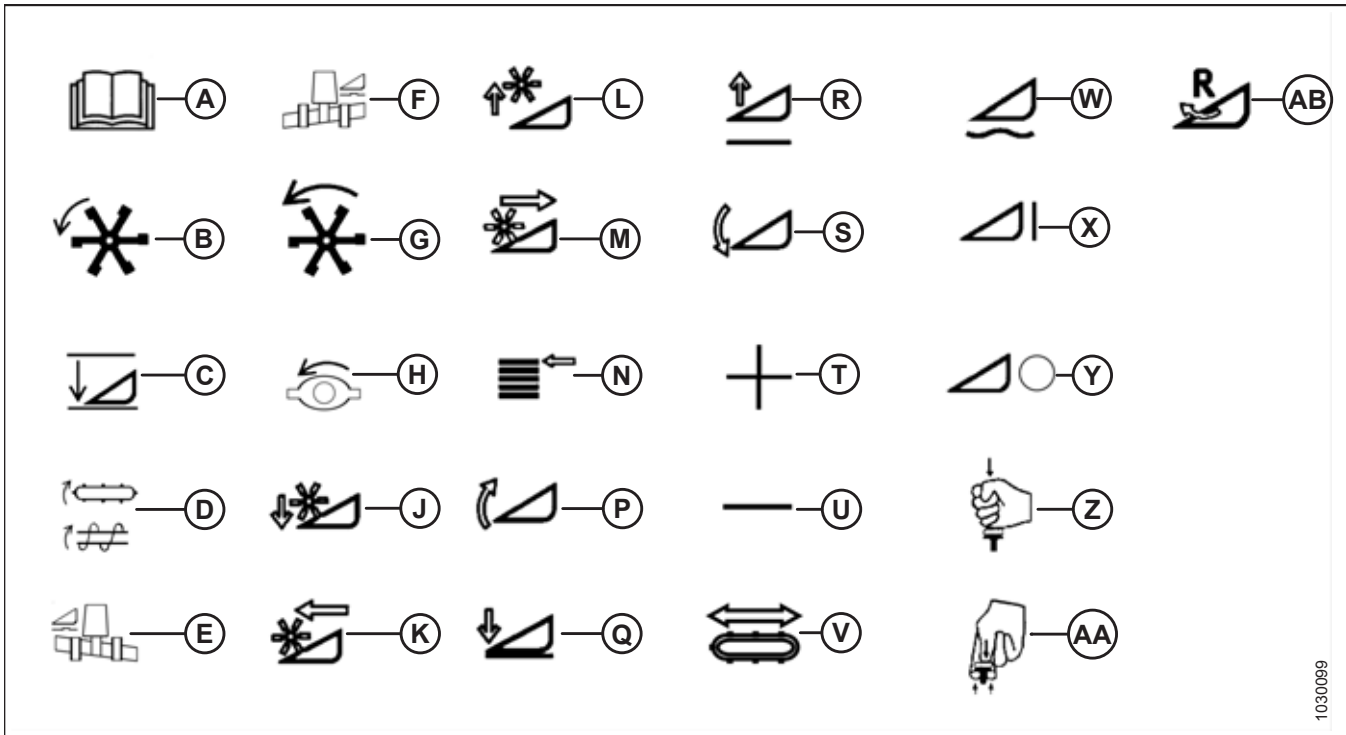

1030099

- | | | |
|----------------------------|----------------------|--------------------------------|
| A - Program | B - Header Index | C - Return to Cut |
| D - Conveyor/Auger Speed | E - Float Left | F - Float Right |
| G - Reel Speed | H - Disc Speed | J - Reel Down |
| K - Reel Forward | L - Reel Up | M - Reel Rearward |
| N - Display Select | P - Header Tilt Up | Q - Header Down |
| R - Header Up | S - Header Tilt Down | T - Increase |
| U - Decrease | V - Deck Shift | W - Float |
| X - Header Engage | Y - Header Disengage | Z - Push Down Header Disengage |
| AA - Pull Up Header Engage | AB - Header Reverse | |

4.3 Operating the Windrower

4.3.1 Operational Safety

CAUTION

Follow these safety precautions:

- Wear close fitting clothing and protective shoes with slip resistant soles.
- Remove foreign objects from the machine and surrounding area.
- Carry with you any protective clothing and personal safety devices that **COULD** be necessary through the day. Don't take chances.
- You may need a hard hat, protective glasses or goggles, heavy gloves, a respirator or filter mask, and/or wet weather gear.



Figure 4.4: Safety Equipment

- Protect against noise. Wear a suitable hearing protective device such as ear muffs or ear plugs to protect against objectionable or uncomfortable loud noises.
- Follow all safety and operational instructions given in your operator's manuals. If you do not have a header manual, get one from your Dealer and read it thoroughly.
- Never attempt to start the engine or operate the machine except from the operator's seat
- Check the operation of all controls in a safe clear area before starting work.
- Check for excessive vibration and unusual noises. If there is any indication of trouble, shut down and inspect the machine. Follow proper shutdown procedure. Refer to [Shutting down the Engine, page 165](#).
- Operate only in daylight or good artificial light.

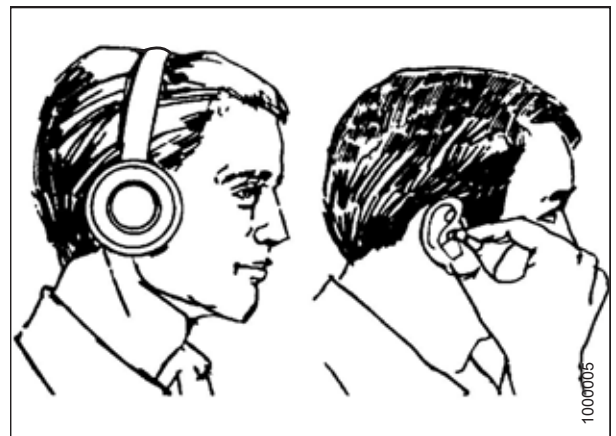

Figure 4.5: Safety Equipment

4.3.2 Break-In Period

There are several items to check and watch out for during the first 150 hours of windrower operation.

DANGER

Before investigating an unusual sound or attempting to correct a problem, place ground speed lever (GSL) in N-DETENT, shut off engine, and remove key.

In addition to the following, check the items specified in [5.12.1 Maintenance Schedule/Record, page 443](#):

- Operate engine at moderate load and avoid extremely heavy or light loading for longer than 5 minutes.
- Avoid unnecessary idling. If engine will be idling longer than 5 minutes after reaching operating temperature, turn key OFF to stop engine.
- Check engine oil level frequently. Watch for any signs of leakage. If oil must be added, refer to [Checking Engine Oil Level, page 341](#).

NOTE:

During the break-in period, a higher than usual oil consumption should be considered normal.

NOTE:

If windrower must be driven in cold weather (below freezing), let engine idle for 3 minutes, and then operate at moderate speed until oil has warmed up.

- Watch coolant gauge in cab for temperature rising beyond normal operating range. Check that coolant level at reserve tank (mounted next to radiator) stays between HOT and COLD marks on tank. Refer to [5.8.6 Engine Cooling System, page 364](#). If over-heating problems occur, check for coolant leaks.

IMPORTANT:

Until you become familiar with the sound and feel of your new windrower, be extra alert and attentive.

NOTE:

Before taking the ground speed lever (GSL) out of Park, let the hydraulic oil warm up to 32°C (90°F).

4.3.3 Preseason Checks / Annual Service

CAUTION

- Review this operator’s manual to refresh your memory on safety and operating recommendations.
 - Review all safety signs and other decals on the windrower and note hazard areas.
 - Be sure all shields and guards are properly installed and secured. Never alter or remove safety equipment.
 - Be sure you understand and have practiced safe use of all controls. Know the capacity and operating characteristics of the machine.
 - Store a properly stocked first aid kit and charged fire extinguisher on the windrower.
1. Perform the following checks:
 - a. Drain off excess hydraulic oil added for storage. Refer to [5.10.3 Changing the Hydraulic Oil, page 416](#).
 - b. Remove plastic bags and/or tape from all sealed openings (air cleaner intake, exhaust pipe, fuel tank).
 - c. Charge battery and install. Be sure terminals are clean and cables are connected securely.
 - d. Adjust tension on air conditioning (A/C) compressor belt. For instructions, refer to [Tensioning Air Conditioner Compressor Belt, page 379](#).
 - e. Distribute A/C refrigerant by cycling A/C switch. For instructions, refer to [Air Conditioning Compressor Coolant Cycling, page 161](#).
 - f. Check the entire A/C system for leakage at the beginning of each season.
 2. Perform annual maintenance. For instructions, refer to [5.12 Maintenance Schedule, page 442](#).

Air Conditioning Compressor Coolant Cycling

IMPORTANT:

Perform the following steps whenever the machine is first started after storage for more than one week:

1. Turn blower switch (A) to the first position, TEMPERATURE control switch (D) to maximum heating, and air conditioning (A/C) control switch (B) to OFF.
2. Start the engine, and operate at low idle until the engine is warm.
3. Click A/C switch (B) from OFF to ON for 1 second, then back to OFF for 5–10 seconds. Repeat this step ten times.

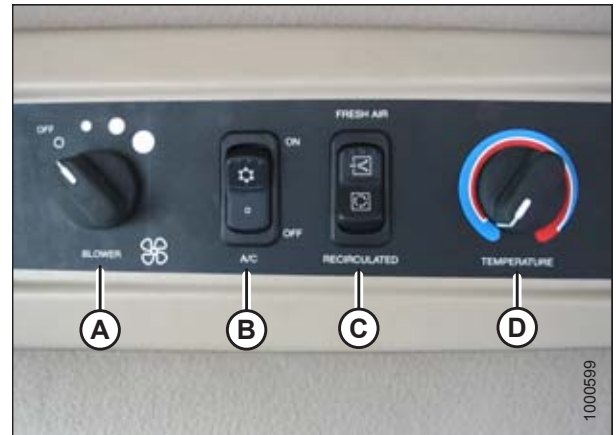

Figure 4.6: Climate Control

- A - Blower Switch
- B - Air Conditioning Switch
- C - Outside Air Switch
- D - Temperature Control

4.3.4 Daily Checks and Maintenance

Perform the following checks and recommended maintenance before operating the windrower every day:

1. Check the machine for leaks.

NOTE:

Use proper procedure when searching for pressurized fluid leaks. For instructions, refer to *Hoses and Lines, page 421*.

2. Check for missing or broken parts.
3. Clean the windows and mirrors to ensure good visibility in all directions. Stand on the platform to access the rear window. Hold onto the handholds on the cab front corners and stand on the header anti-slip strips to wash the front window.
4. Clean all lights and reflective surfaces to maintain visibility to others.
5. Perform daily maintenance. For instructions, refer to *5.12 Maintenance Schedule, page 442*.

4.3.5 Engine Operation

Starting the Engine

Carefully review the following topic before attempting to start the engine. It contains important information about Operator safety and the engine ignition system.

 **DANGER**

- This machine has safety devices which allow the engine to start only when the ground speed lever is in N-DETENT, the steering wheel is locked in the NEUTRAL position, and the header drive switch is in the OFF position. Under no circumstances are these devices to be deliberately rewired or misadjusted so that the engine can be started with controls out of NEUTRAL.
- Do NOT start engine by shorting across starter or starter relay terminals. The machine will start and move with drive engaged if normal starting circuitry is bypassed.
- Start engine only from operator's seat with controls in NEUTRAL. NEVER start engine while standing on ground. Never try to start engine with someone under or near machine.
- Before starting engine, be sure there is plenty of ventilation to avoid asphyxiation.

 **WARNING**

If starter engages with steering wheel unlocked, ground speed lever out of NEUTRAL, or header clutch engaged, DO NOT START ENGINE. Contact your Dealer.

IMPORTANT:

Do NOT tow machine to start the engine. Damage to hydrostatic drives will result.

OPERATION

1. The battery main disconnect switch (A) is located on the right frame rail, behind the maintenance platform, and can be accessed by moving the platform. Ensure switch is in the POWER ON position.

WARNING

Before starting engine, fasten your seat belt and ensure trainer's seat belt is used if seat is occupied. Seat belts improve safety if used and maintained properly.

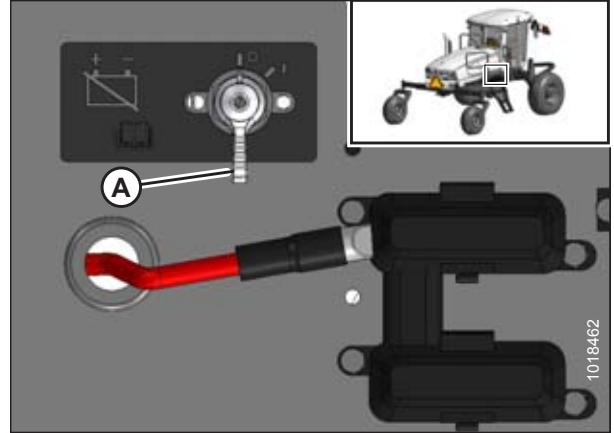

Figure 4.7: Battery Disconnect Switch

2. Ensure lock (A) at the base of the steering column is engaged at cab-forward or engine-forward position.
3. Move ground speed lever (GSL) (B) into N-DETENT.
4. Turn steering wheel until it locks. It may be possible to move the steering wheel slightly in the locked position.

IMPORTANT:

Do **NOT** attempt to force the wheel out of locked position as damage to the traction system may occur.

5. Fasten seat belt.
6. Push HEADER DRIVE switch (C) to ensure it is OFF.



Figure 4.8: Operator Controls

CAUTION

Check to be sure all bystanders have cleared the area.

7. Set throttle (A) to START position—fully back.
8. Sound horn three times.
9. Turn ignition key (B) to RUN position. A single loud tone sounds, engine warning lights illuminate as a self-test, and cab display module (CDM) displays HEADER DISENGAGED and IN PARK.
10. Turn ignition key (B) to START position until engine starts, and then release key. CDM displays programmed header data for 5 seconds if attached, and then returns to previous display.



Figure 4.9: Operator Console

IMPORTANT:

The machine gauges and instruments provide important information about machine operation and condition. Familiarize yourself with the gauges and monitor them carefully during start-up operation. Refer to [3.16 Engine Controls and Gauges](#), page 65.

OPERATION

IMPORTANT:

- Do **NOT** operate starter for longer than 15 seconds at a time.
- If engine does not start, wait at least 2 minutes before trying again.
- After the third 15 second crank attempt, allow solenoid to cool for 10 minutes before further cranking attempts. If engine still does not start, refer to [6.1 Engine Troubleshooting, page 447](#).
- Do **NOT** operate engine above 1500 rpm until engine temperature gauge is above 40°C (100°F).

NOTE:

When the engine temperature is below 5°C (40°F), follow the procedure for a normal start. The engine will cycle through a period where it appears to labor until the engine warms up. The throttle is nonresponsive during this time as the engine is in WARM UP mode. This mode will last from 30 seconds to 3 minutes depending on the temperature. After the engine has stabilized and is idling normally, the throttle becomes active.

NOTE:

Before taking the GSL out of Park, let the hydraulic oil warm up to 32°C (90°F).

Engine Warm-Up

Allow engine to run with throttle lever (A) at or near low-idle position until temperature gauge (B) reaches approximately 40°C (100°F). Before taking the ground speed lever (GSL) out of Park, let the hydraulic oil warm up to 32°C (90°F).

NOTE:

Scroll through the cab display module (CDM) to view the engine temperature. For more information, refer to [Engine Temperature, page 167](#).



Figure 4.10: Operator Console

Engine Intermediate Speed Control

The engine operating speed can be programmed to enable the windrower to operate at reduced engine rpm (that is, 1800, 2000, or 2200 rpm) without significantly affecting the ground or header speeds. The default setting is 2200 rpm or the last selected rpm.

NOTE:

Previous M Series windrower models included an OFF (full throttle) option which is **NOT** available on the M155.

Engine intermediate speed control (ISC) is useful when operating loads are reduced such as in light crop conditions that do not require the maximum engine rpm. Reduced engine speed lowers fuel consumption, noise levels, and exhaust emissions in addition to reducing engine wear.

The programmed engine speed is activated when the header is engaged.

Programming instructions are provided in [Setting the Engine Intermediate Speed Control \(ISC\) RPM, page 110](#).

OPERATION

Shutting down the Engine

CAUTION

Park on a flat, level surface with the header on the ground, the ground speed lever (GSL) in N-DETENT position, and the steering wheel in locked position (centered). Wait for the combine display module (CDM) to beep and display an “In Park” message to confirm the park brakes have engaged.

IMPORTANT:

Before stopping the engine, run at low idle for approximately 5 minutes to cool hot engine parts (and allow turbocharger to slow down while engine oil pressure is available).

1. Lower header.
2. Place GSL (B) into N-DETENT.
3. Lock steering wheel.
4. Turn ignition key (A) counterclockwise to OFF position.



Figure 4.11: Operator Console

OPERATION

Filling the Fuel Tank

Fill the fuel tank daily, preferably at the end of the day's operation to help prevent condensation in the tank.

WARNING

To avoid bodily injury or death from unexpected startup of the machine, always stop the engine and remove the key from the ignition before leaving the operator's seat for any reason.

WARNING

- To avoid personal injury or death from explosion or fire, do NOT smoke or allow flame or sparks near fuel tank when refueling.
- NEVER refuel the windrower when the engine is hot or running.
- To avoid electric discharge and the risk of a fire or explosion, ensure that the fuel delivery system is properly bonded and grounded. A bonded fuel delivery system has an electrically conductive and unbroken connection between all components of the fuel delivery system (fuel supply tank, transfer pump, transfer hose, nozzle, and others). A wire connection from the fuel delivery system to the machine chassis will equalize the static electric potential between the two machines, further reducing the chance of a static electric discharge. A properly grounded fuel delivery system has an electrically conductive connection from the fuel delivery system tank to earth ground to allow static and electrical charge dissipation.

CAUTION

Do NOT allow tank to empty. Running out of fuel can cause air locks and/or contamination of the fuel system. Refer to [System Priming, page 363](#).

1. Shut down the engine, and remove the key from the ignition.
2. Stand on either platform to access the fuel tank filler pipe.
3. Clean the area around filler cap (A).
4. Turn cap handle (B) counterclockwise until loose and then remove cap.
5. Fill the tank with approved fuel. Refer to inside back cover for recommended fuel.

IMPORTANT:

Do NOT fill the tank completely—space is required for expansion. A filled tank could overflow if exposed to a rise in temperature, such as direct sunlight.

6. Replace fuel tank cap (A) and turn cap handle (B) clockwise until snug.

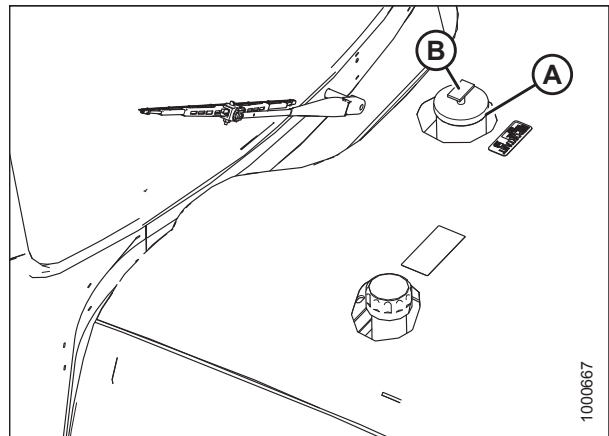

Figure 4.12: Fuel Filler Cap

OPERATION

Engine Temperature

The normal engine operating temperature range is 82–104°C (180–220°F). Engine temperature is indicated by gauge (B) on the operator's console.

If the temperature exceeds 104°C (220°F), an ongoing intermittent tone will be heard and the cab display module (CDM) will flash ENGINE TEMP. Stop the engine immediately and determine the cause. The tone will stop and the CDM will return to normal when the temperature drops below 102°C (215°F).

NOTE:

Before taking the ground speed lever (GSL) out of Park, let the hydraulic oil warm up to 32°C (90°F).



Figure 4.13: Operator Console

OPERATION

Engine Oil Pressure

The nominal engine oil pressure is 69 kPa (10 psi) at low idle and 380 kPa (55.1 psi) at maximum rated speed.

If the oil pressure drops below the preset level of 52 kPa (7.5 psi), the cab display module (CDM) flashes an error code and error message.

If the STOP ENGINE light illuminates, stop the engine **IMMEDIATELY** and investigate.

If the yellow CAUTION light illuminates, you may continue operations and investigate later, but you are **STRONGLY** advised to monitor the situation carefully.

Cab Display Module Voltage Display

The electrical system voltage is displayed on the cab display module (CDM) when selected with the SELECT button on the ground speed lever (GSL) handle or the SELECT switch on the CDM. The display indicates the condition of the battery and alternator.

Ignition	Engine	Reading	Indicated Condition
ON	Running	13.8–15.0	Normal
		> 16.0 ²²	Regulator out of adjustment
		< 12.5 ²²	Alternator not working or regulator out of adjustment
	Shut down	12.0	Battery normal

Engine Warning Lights

There are four engine warning lights that illuminate if abnormal conditions occur while the engine is running. The engine warning lights should **NOT** be illuminated under normal operating conditions. For more information, refer to [Engine Warning Lights, page 84](#).

22. Display flashes voltage reading with single loud tone. Repeats every 30 minutes until condition is fixed.

4.3.6 Driving the Windrower

Review the following list of dangers, warnings, and cautions before operating the windrower for the first time, or when training new operators.

DANGER

- NEVER move the ground speed lever (GSL) or the steering wheel until you are sure all bystanders have cleared the area.
- Make sure the area is clear before making turns, as the ends of a header travel in a large arc.
- Check the operation of all controls in a safe, clear area before starting work.
- Understand the capacity and operating characteristics of your machine.
- Do NOT allow riders in or on the machine.
- Do NOT operate unless seated in the operator's position.
- Do NOT attempt to get on or off a moving windrower.
- AVOID sudden starts and stops.
- AVOID inclines, ditches, and fences.
- Do NOT rapidly accelerate or decelerate when turning.
- REDUCE your speed before turning, crossing slopes, or travelling over rough ground.
- Do NOT allow anyone to stand behind the machine while operating. Foreign objects may be forcibly ejected.

WARNING

Seat belts can help ensure your safety when properly used and maintained.

- Before starting the engine, fasten your seat belt, and ensure that the training seat occupant's seat belt is securely fastened.
- Never wear a seat belt loosely or with slack in the belt system. Never wear the belt in a twisted condition or pinched between the seat structural members.

WARNING

Avoid driving the machine with the header removed. Removing the header decreases the weight on the drive wheels, reducing steering control. If you must drive the machine with the header removed and without a MacDon weight system.

- Use transmission low speed range, do NOT exceed 1500 rpm engine speed, and avoid loose gravel and slopes.
- Never use the windrower as a towing vehicle when the header is removed, except as instructed in *Towing Header with Windrower, page 183*. There is insufficient weight on the drive wheels to provide steering control.
- If control of machine is lost, immediately pull ground speed lever (GSL) to NEUTRAL.
- Be aware that cab structure will NOT withstand a roll-over. Because of windrower shape characteristics, a roll-over protected (ROPS) cab is not required.

 **WARNING**

When travelling on steep slopes:

- Lower the header and reduce speed.
- Move the GROUND SPEED RANGE switch to L (low range).
- If the ground speed is greater than or equal to 40 km/h (25 mph), the CDM will display a warning message (SLOW DOWN) with an audible alert. Move the GSL closer to NEUTRAL to reduce speed.

 **CAUTION**

Hydrostatic steering control is different from conventional steering mechanisms:

- Hydrostatic steering is more sensitive than mechanical steering. Do NOT make abrupt changes in steering direction.
- Steering is opposite to normal when driving in reverse.
- With the engine running, moving the ground speed lever out of N-DETENT unlocks steering. Any movement of the steering wheel will then cause the machine to move, even if the ground speed lever has not been moved forward or rearward from the NEUTRAL position.
- The brakes are only on when the GSL is in N-DETENT and the steering wheel is centered and locked.

Entering and Exiting the Windrower

 **CAUTION**

To prevent slipping and possible injury, ALWAYS face the windrower and use the hand rail when dismounting (or mounting). NEVER attempt to get on or off a moving windrower. Before leaving the operator's seat for any reason:

- Park on a flat, level surface with the ground speed lever in N-DETENT position and the steering wheel in locked position (centered). Wait for the CDM to beep and display an "In Park" message to confirm the park brakes have engaged.
- Fully lower the header and reel.
- Disengage the header drives.
- To avoid bodily injury or death from unexpected startup of machine, always stop engine and remove key from ignition.
- Turn off the lights unless required for inspection purposes.
- Release the seat belt.
- Turn off the wipers.
- Raise the armrest and steering wheel for easier exit and re-entry.
- Lock the cab door when leaving the windrower unattended. (When the door is locked, it can still be opened from inside the cab.)

OPERATION

Swing-away platforms and stairs (A) are provided on both sides of the windrower to accommodate cab-forward and engine-forward access to the operator's station, as well as several maintenance tasks.

The left cab-forward side platform is shown in the rearward (cab-forward) position.

Two doors (B) are provided for cab entry and exit in either cab-forward mode or engine-forward mode. Enter the cab using the door opposite the operator's console.

NOTE:

When the engine is shut down, rear field lights turn on for 60 seconds to illuminate the platform and stairs.

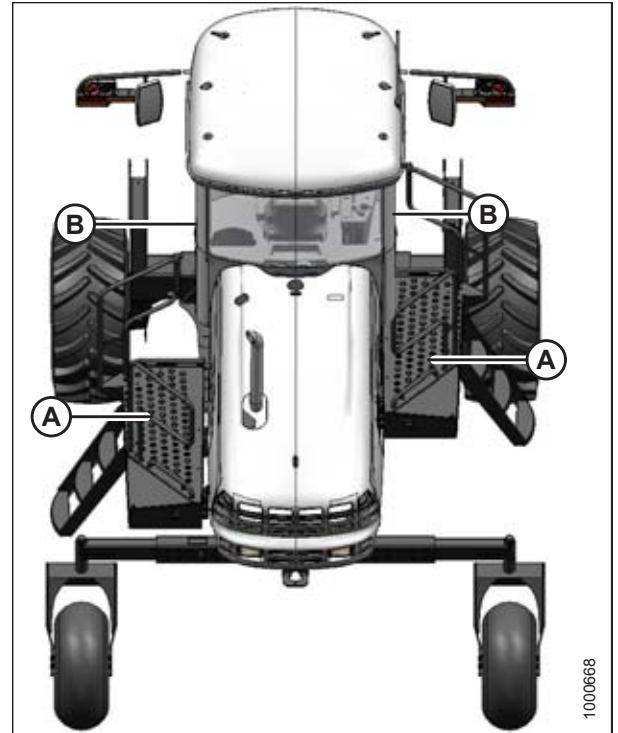

Figure 4.14: Platforms and Doors

Driving Forward in Cab-Forward Mode

CAUTION

Operate both the steering wheel and ground speed lever (GSL) slowly for familiarization. Avoid the common tendency of new Operators to oversteer.

WARNING

Do NOT drive the windrower on the road in cab-forward configuration, unless it is equipped with the proper lighting and markings for cab-forward road travel.

In cab-forward mode, the operator's station is facing away from the engine. If necessary, swivel the operator's seat to cab-forward position as follows:

1. Place GSL (A) in N-DETENT. The engine can be running.

IMPORTANT:

If the GSL is NOT in N-DETENT, the GSL cable may be damaged when you swivel the operator's station.

2. Pull up on knob (B) and hold to release latch (C) at the base of the steering column.
3. Turn the steering wheel counterclockwise to pivot the operator's station clockwise 180° until the pin engages the latch to secure the operator's station in the new position.
4. Ensure the seat belt is fastened.
5. If it is not already running, start the engine. For instructions, refer to *Starting the Engine, page 162*.

6. Raise the header just enough to clear common obstacles. Ensure the header is not raised too high and the operator has good visibility out of the cab and that motorists are able to see the header lights.

7. There are two cab-forward speed ranges. Set GROUND SPEED RANGE switch (A) to either H (0–25.7 km/h [16 mph]), or L (0–17.7 km/h [11 mph]).
8. Slowly push throttle (B) to full forward (operating speed). The cab display module (CDM) should display 2320–2350 rpm at location (C).

CAUTION

Check again to be sure all bystanders have cleared the area.

9. Move the GSL (E) out of N-DETENT and slowly forward to desired speed which will be displayed at location (D).



Figure 4.15: Cab-Forward Mode



Figure 4.16: Operator Console



Figure 4.17: Operator Console

Driving Reverse in Cab-Forward Mode

WARNING

Back up slowly. Steering is opposite to normal when reversing. Hold steering wheel at the bottom and turn wheel in direction you want the rear (cab-forward) of the machine to travel.

1. Move GROUND SPEED RANGE switch (A) to L (low-range position).
2. Move throttle lever (B) to a mid-range position.

NOTE:

Steering will be less sensitive in low-speed range; reduced engine speed.

CAUTION

Check again to be sure all bystanders have cleared the area.

3. Move the ground speed lever (GSL) rearward to desired speed.
4. Steer as shown.



Figure 4.18: Operator's Console

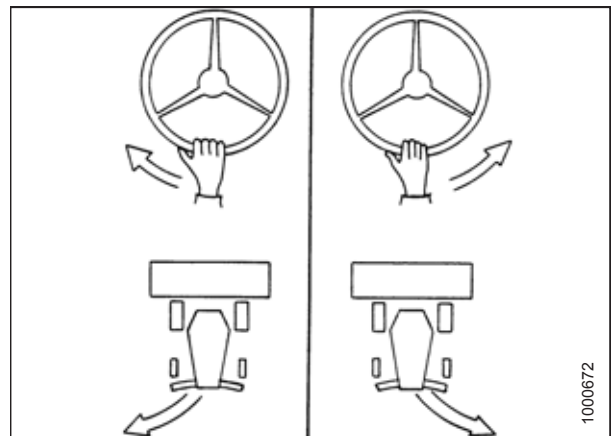

Figure 4.19: Cab-Forward Mode

Driving Forward in Engine-Forward Mode

In the engine-forward mode, the operator’s station is facing toward the engine. If necessary, swivel the operator’s station to engine-forward position as follows:



Figure 4.20: Engine-Forward – Seat Faces Engine

1. Place ground speed lever (GSL) (A) in N-DETENT and lock steering wheel. Engine can be running.

IMPORTANT:

If GSL is **NOT** in N-DETENT, the GSL cable may be damaged when you swivel the operator’s station.

2. Pull up on knob (B) and hold to release latch (C) at base of steering column.
3. Turn steering wheel clockwise to pivot operator’s station counterclockwise 180° until pin engages latch to secure operator’s station in new position.
4. If it is not already running, start the engine. For instructions, refer to [Starting the Engine, page 162](#).



Figure 4.21: Engine-Forward – Seat Faces Engine

5. Set GROUND SPEED RANGE switch (A) to **H** for road speed (0–37 km/h [23 mph]). Cab display module (CDM) will display ROAD GEAR at location (F) and an alarm will briefly sound.
6. Slowly push throttle (B) to full forward (operating speed). CDM should display 2320–2350 rpm at location (C).

CAUTION

Check to be sure all bystanders have cleared the area.

7. Slowly move the GSL (E) forward to desired speed which will be displayed at location (D).

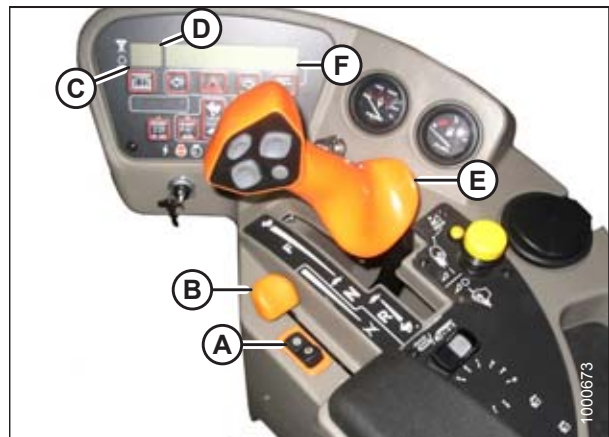

Figure 4.22: Operator Console

CAUTION

Operate both steering wheel and ground speed lever slowly while becoming familiar with the machine. Remember that steering is more sensitive when speed-range control is in high road speed position. Avoid the common tendency of new Operators to oversteer.

OPERATION

8. If more tractive (lugging) power is required (for example, when driving up a ramp, up a hill, or up out of a ditch):
 - a. Move GSL (E) closer to NEUTRAL.
 - b. Switch speed-range control (A) to L (low range).
9. Once the lugging condition no longer exists:
 - a. Set GSL (E) to **NOT MORE THAN HALF** maximum forward speed.
 - b. Move speed-range switch (A) to H (high range). Steering is more sensitive in this speed range.

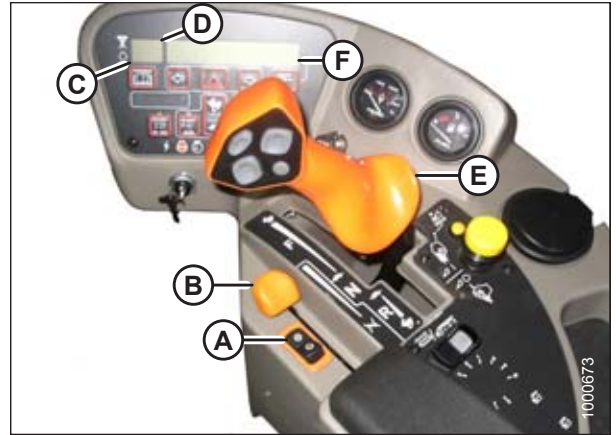

Figure 4.23: Operator Console

Driving in Reverse in Engine-Forward Mode

WARNING

Back up slowly. Steering is opposite to normal when reversing. Hold steering wheel at the bottom and turn wheel in direction you want the rear (cab-forward) of the machine to travel.

1. Move speed-range switch (A) to L (low-range position).
2. Move throttle lever (B) to a mid-range position.

NOTE:

Reversing in low-speed range and at reduced engine speed is recommended since steering will be less sensitive than at higher speed settings.

CAUTION

Check to be sure all bystanders have cleared the area.

3. Move the ground speed lever (GSL) (C) rearward to desired speed.
4. Steer as shown.



Figure 4.24: Operator Console

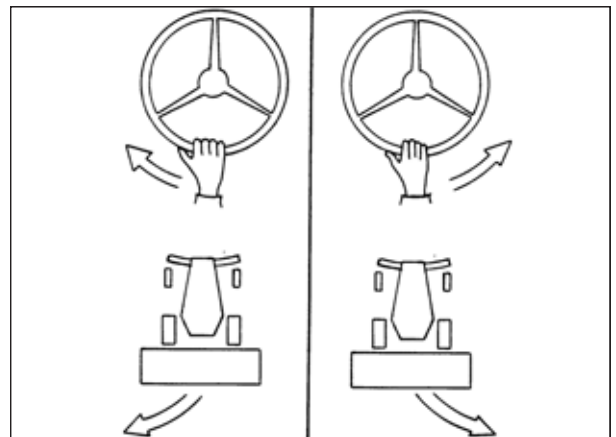

Figure 4.25: Steering the Windrower

OPERATION

Spin Turning

Hydrostatic steering provides significantly more maneuverability than mechanical steering.

CAUTION

Be sure area is clear before making turns. Although windrower pivots on the spot, the ends of the header travel faster and in a large arc.

1. Move the ground speed lever (GSL) (A) out of N-DETENT towards the seat and hold.
2. Slowly turn the steering wheel in the desired direction of turn. The windrower will pivot between the drive wheels.
3. To increase the turn radius, slowly move the GSL away from NEUTRAL. Remember that this will increase ground speed as well.
4. To stop the turn, slowly turn the steering wheel back to its centered position.



Figure 4.26: Operator Console

OPERATION

Stopping

WARNING

Do **NOT** move the ground speed lever (GSL) rapidly back to NEUTRAL. You may be thrown forward by a sudden stop and the wheels may skid, reducing steering control. Always wear a seat belt when operating the windrower.

CAUTION

Park on a flat, level surface with the GSL in N-DETENT position and the steering wheel in locked position (centered). Wait for the CDM to beep and display an “In Park” message to confirm the park brakes have engaged.

To stop the windrower:

1. **SLOWLY** return GSL (A) to NEUTRAL and into N-DETENT.
2. Turn steering wheel until it locks.
3. Move throttle lever (B) to low idle position.

NOTE:

Avoid unnecessary idling. Stop engine if it will be idling for longer than 5 minutes.

NOTE:

Brakes are automatically engaged when steering wheel is locked in NEUTRAL position.

IMPORTANT:

Before stopping the engine, run at low idle for approximately 5 minutes to cool hot engine parts (and allow turbocharger to slow down while engine oil pressure is available).

4. Turn the ignition key counterclockwise to the OFF position.



Figure 4.27: Operator Console

4.3.7 Adjusting Caster Tread Width

The rear casters can be adjusted to a narrow tread width to allow loading and shipping without having to remove them.

A narrow tread width also suits smaller headers by allowing more space for the uncut crop and provides more maneuverability around poles, irrigation inlets, or other obstacles.

A wider tread width is useful in heavy crops that produce large windrows so that runover is reduced.

WARNING

To avoid bodily injury or death from unexpected startup of the machine, always stop the engine and remove the key from the ignition before leaving the operator's seat for any reason.

CAUTION

Park on a flat, level surface with the header on the ground, the ground speed lever (GSL) in N-DETENT position, and the steering wheel in locked position (centered). Wait for the combine display module (CDM) to beep and display an "In Park" message to confirm the park brakes have engaged.

Adjust the caster tread width as follows:

1. Park the windrower on level ground, shut down the engine and remove the key from the ignition.
2. Raise the rear of the windrower slightly so that most of the weight is off the casters, using a jack or other lifting device under the frame at location (A).

NOTE:

Lifting device should have a lifting capacity of at least 2270 kg (5000 lb.).

3. Remove six bolts (B) (four on backside, two on underside) and washers from the left and right of the walking beam.

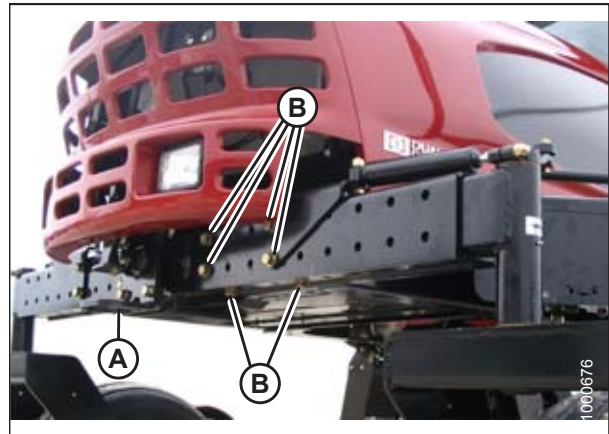

Figure 4.28: Caster Wheel Extensions

4. Slide the extensions inboard or outboard equal amounts and align holes at desired location.

NOTE:

Use the caster wheels to assist in moving the extensions by rotating the casters until the wheels are parallel to the walking beam.



Figure 4.29: Caster Wheel Extensions

OPERATION

IMPORTANT:

Caster wheels must be an equal distance (A) from the center of the windrower.

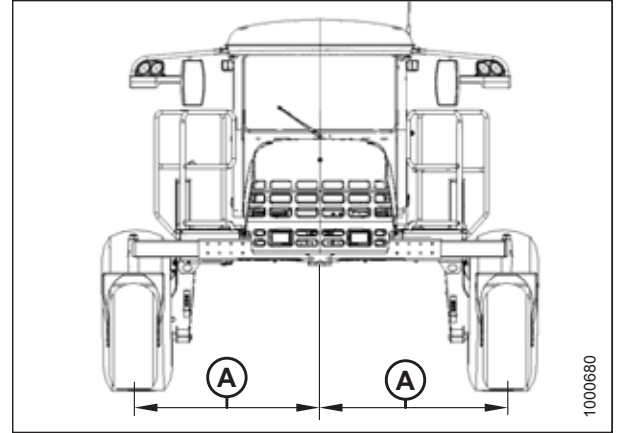

Figure 4.30: Adjustable Caster Wheels

5. Line up holes, then install shorter bottom bolts (B).
6. Position bracket (A) and install back bolts (C).
7. Tighten bolts as follows:
 - a. Snug bottom bolts (B), then snug back bolts (C).
 - b. Tighten and torque back bolts (C) to 447 Nm (330 lbf-ft).
 - c. Tighten and torque bottom bolts (B) to 447 Nm (330 lbf-ft).
8. Lower windrower to ground.

IMPORTANT:

Torque bolts after first 5 and 10 hours of operation.

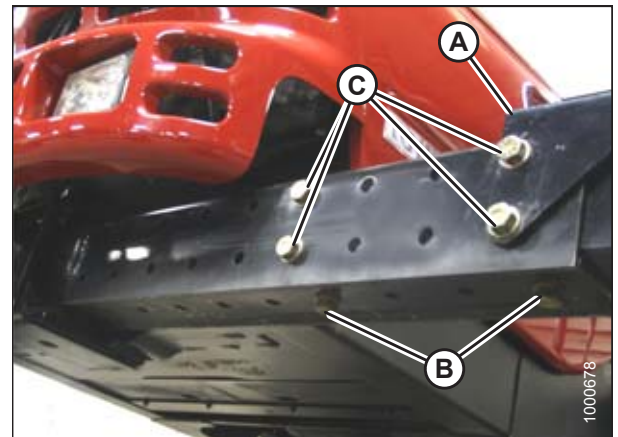

Figure 4.31: Caster Wheel Extensions

4.3.8 Transporting

Driving on the Road

The M155 Self-Propelled Windrower is designed to be driven on the road with the engine facing forward to provide better visibility for the Operator and improved stability for the machine. The windrower can also be driven on the road in cab-forward mode, but at a reduced speed and under restricted conditions.

WARNING

Collision between windrower and other vehicles may result in injury or death.

WARNING

When driving windrower on public roadways:

- Obey all highway traffic regulations in your area. Use pilot vehicles in front and rear of windrower if required by law.
- Use slow-moving vehicle emblem and flashing warning lights unless prohibited by law.
- If width of attached header impedes other vehicle traffic, remove header and install a MacDon approved weight box.

WARNING

- Do NOT drive windrower on the road in the cab-forward mode, unless the optional lighting and marking kit is installed, as lighting/reflector visibility will not be compliant with road regulations. Refer to [7.4.1 Lighting and Marking for Cab-Forward Road Travel, page 466](#).
- Do NOT drive windrower on a road or highway at night or in conditions that reduce visibility, such as fog or rain. The width of the windrower may not be apparent under these conditions.

CAUTION

Operate both steering wheel and ground speed lever slowly while becoming familiar with the machine. Remember that steering is more sensitive when speed-range control is in high road speed position. Avoid the common tendency of new Operators to oversteer.

CAUTION

Check local laws for width regulations and lighting and marking requirements before transporting on roads.

OPERATION

Before driving windrower on a roadway:

1. Ensure HEADER DRIVE switch (A) is pushed to OFF position (down).
2. Clean flashing amber lamps, red tail and head lamps, and check that they work properly.
3. Clean all reflective surfaces and slow moving vehicle emblems.
4. Adjust interior rear view mirror and clean windows.



Figure 4.32: Header Drive Switch

5. Push LIGHT switch to ROAD position (A) to activate lamps. Always use these lamps on roads to provide warning to other vehicles. Refer to [3.7 Exterior Lighting, page 49](#).

NOTE:

If the auto-road light feature is activated (that is, when the windrower is in engine- or cab-forward mode, out of park, in high range switch position, and with header off), only the two front corner field lights will turn on; the remaining field lights are disabled.

6. Use HIGH/LOW LIGHTS (B) as required when other vehicles are approaching.
7. Push BEACON switch (C) ON to activate beacons.

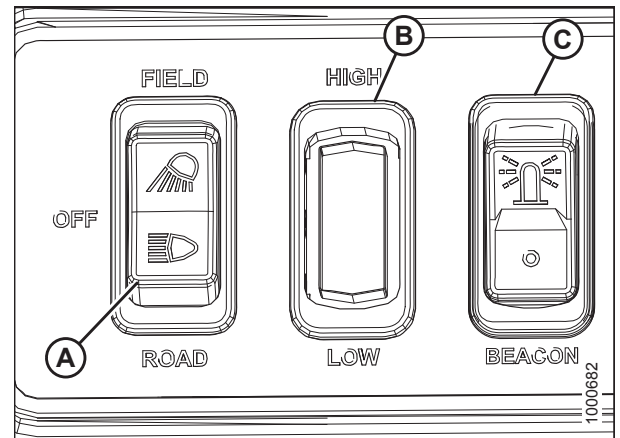

Figure 4.33: Light Switches

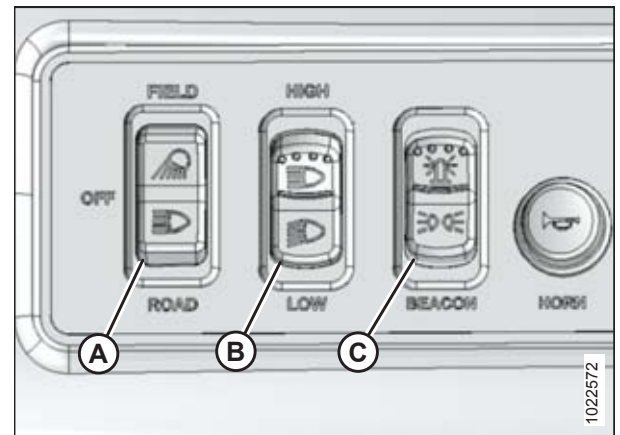

Figure 4.34: Light Switches – Russia

OPERATION

- Press switch (A) on cab display module (CDM) to activate hazard lights.

IMPORTANT:

Switch ON the beacon and hazard lights when travelling on the road with the transmission in low range.



Figure 4.35: CDM

- Set GROUND SPEED RANGE switch (A) for ROAD speed. CDM will display ROAD GEAR at location (F) if windrower is in engine-forward mode.

NOTE:

Windrower can be moving, but speed must be less than 8 km/h (5 mph) for road gear to engage.

- Slowly push throttle (B) to full forward (operating speed). CDM should display 2320–2350 rpm (C).
- Slowly move ground speed lever (GSL) (E) forward to desired speed which will be displayed at location (F).
- To slow the windrower, pull GSL (E) rearward to decrease the speed.
- Move GSL (E) to N-DETENT.
- Lock the steering wheel.
- Shut off the engine.
- If towing a header, refer to [Towing Header with Windrower, page 183](#) for more information.



Figure 4.36: Operator Console

OPERATION

Towing Header with Windrower

The windrower can be used to tow a MacDon draper header that has the slow speed transport option installed. Ensure the optional weight box or an approved header transporter is installed on the windrower to transfer weight to the lift arms.

WARNING

- A windrower without a header or weight box must **NOT** be used to tow headers due to reduced traction and possible loss of control.
- For towed equipment without brakes, do **NOT** exceed 32 km/h (20 mph).

CAUTION

- To tow a header with an M155 Self-Propelled Windrower, the header must be equipped with the appropriate equipment to comply with local regulations.
- Before towing, conduct a pretrip inspection to verify signal lighting and safety equipment is installed and functioning properly.
- Do **NOT** exceed the Combined Gross Vehicle Weight (CGVW) specified in table 4.1, page 183.
- To prevent damage and/or loss of control, ensure the machine and attached equipment are within the following weight limits:



Figure 4.37: Towing a Header

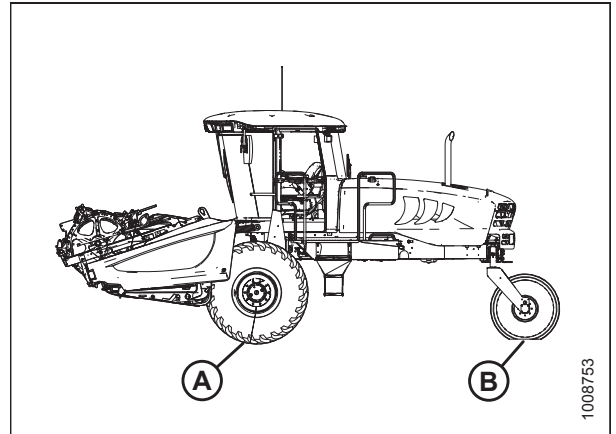

Figure 4.38: M Series Windrower

Table 4.1 Maximum Weight

		kg	lb.
Maximum GVW (includes mounted implements)		9750	21,500
Maximum CGVW (includes towed and mounted implements)		10,480	23,100
Weight (A) on both drive wheels	Maximum	8500	18,750
	Minimum	4570	10,070
Maximum weight (B) on both caster tires		2750	6050

OPERATION

Converting from Field to Transport Mode

WARNING

To avoid bodily injury or death from unexpected startup of the machine, always stop the engine and remove the key from the ignition before leaving the operator's seat for any reason.

DANGER

To avoid bodily injury from fall of raised header, always engage safety props when working on or around raised header, and before going under header for any reason.

1. Set the header on the ground (field position).
2. Disconnect the following hydraulic and electrical connections:
 - a. **Left Side** – Arrange the hydraulic hoses and electrical cable into storage position. For instructions, refer to the header operator's manual.
 - b. **Right Side** – Release the multi-link and place into storage on the windrower. For instructions, refer to the header operator's manual.
3. Retrieve the temporary lift pin from its storage location on the weight box and install into its rear hole (A) at the top of the lift arms. This provides additional lift height for transport wheel deployment.

CAUTION

Check to be sure all bystanders have cleared the area.

4. Start the engine and raise the header to full height.
5. Stop the engine and engage safety props on the lift cylinders. Remove the key from the ignition.
6. Deploy the header slow speed transport system. Refer to header operator's manual.

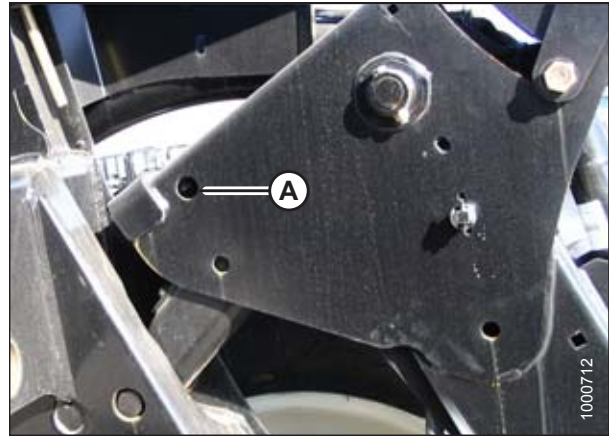

Figure 4.39: Lift Arms



Figure 4.40: Header in Transport Mode

OPERATION

7. Remove float pin from engaged position (A) and insert in storage location (B). Secure with lynch pin.

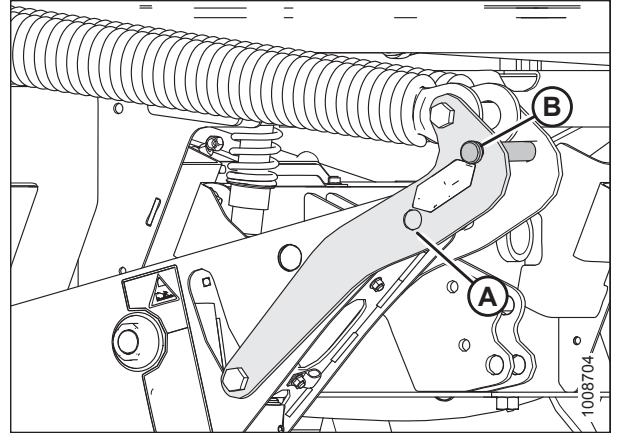

Figure 4.41: Lift Arms

8. Remove pins (A) from lower end of lift linkages.

NOTE:

Pins (A) are also used to secure weight box to windrower linkage.

9. Release the safety props on the header lift cylinders. For instructions, refer to [4.4.1 Engaging and Disengaging Header Safety Props](#), page 196.
10. Start the engine and lower the header down onto the transport wheels.

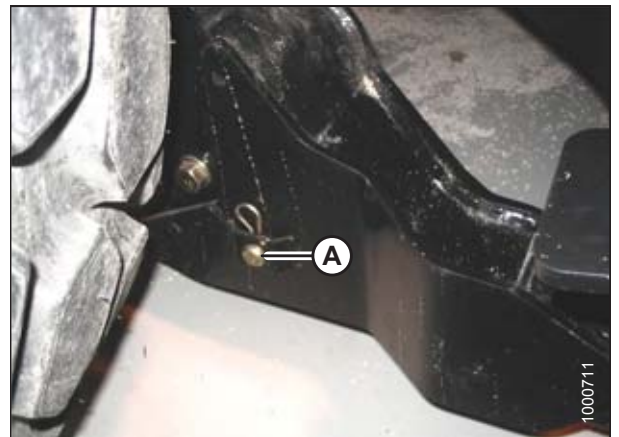

Figure 4.42: Lift Arms

11. Use the HEADER TILT switches to release load on the center-link if necessary.
12. Shut down the engine and remove the key from ignition.

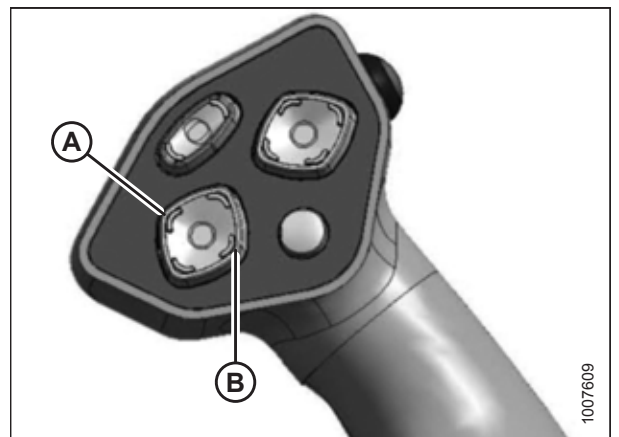

Figure 4.43: Ground Speed Lever (GSL)

A - Header Tilt Down

B - Header Tilt Up

OPERATION

Disconnect the center-link as follows:

13. If using hydraulic link, disconnect the center-link as follows:
 - a. Pull up on latch (A), and position latch into notch (B) on top of hook.
 - b. Release the safety props on the header lift cylinders. For instructions, refer to [4.4.1 Engaging and Disengaging Header Safety Props](#), page 196.
 - c. Lower the header down onto the transport wheels.
 - d. Disengage the top-link from the header. If necessary, use the HEADER TILT switch to release load on the cylinder.
14. To unlock the center-link, pull up on latch (A) and position latch into notch (B) on top of hook.
15. Lift the center-link off the header pin.

NOTE:

If the center-link self-alignment kit is installed, start the engine and raise the center-link with the REEL UP switch on the ground speed lever (GSL).

16. Slowly back the windrower away from the header.
17. Shut the engine off and remove the key from the ignition.
18. If using a mechanical link, disconnect the center-link as follows:

- a. Loosen nut (A) and rotate barrel (B) to relieve load on link.
- b. Remove cotter pin (D) on pin (C), and remove pin to disconnect from windrower. Reinstall pin in header.

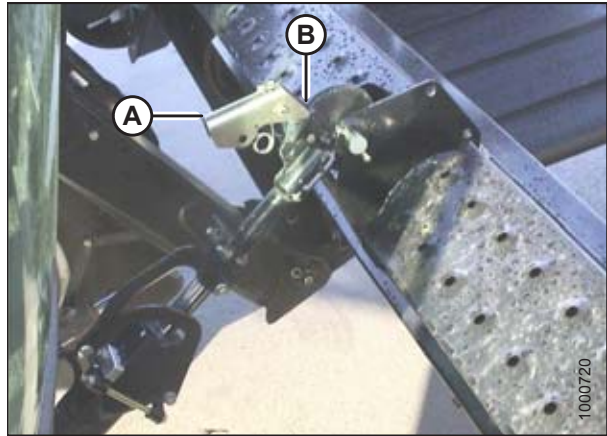

Figure 4.44: Hydraulic Link

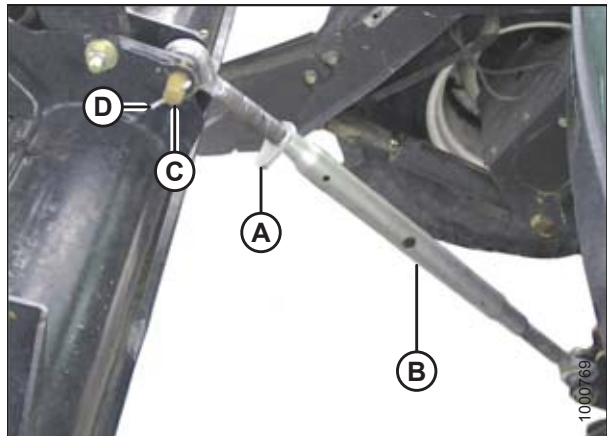

Figure 4.45: Mechanical Link

Converting from Transport Mode to Field Operation

⚠ WARNING

To avoid bodily injury or death from unexpected startup of the machine, always stop the engine and remove the key from the ignition before leaving the operator's seat for any reason.

1. Stop the engine and remove the key from the ignition.
2. Disconnect electrical harness at connector (B) from the windrower and store harness (A) on weight box.



Figure 4.46: Electrical Harness

3. Disconnect wiring connector (A) at front wheel.



Figure 4.47: Header Transport Wheel

4. Remove clevis pin (D).
5. Push latch (C) and lift tow-bar (A) from hook. Release latch and replace clevis pin.
6. Unhook tow-bar from weight box.



Figure 4.48: Header Transport Wheel

CAUTION

Check to be sure all bystanders have cleared the area.

7. Start the engine and lower lift arms until rear of lift arms floats up and away from the lift arm mechanism.
8. Stop the engine and remove the key from the ignition.
9. Remove temporary lift pins (A) from weight box and install pins into holes at rear of lift arms.
10. Start the engine and fully raise lift arms. Stop the engine and remove the key from the ignition.
11. Engage lift cylinder safety props. Refer to [4.4.1 Engaging and Disengaging Header Safety Props](#), page 196.
12. Disengage the float and store pins at storage hole location (B). Move float pins from working hole location (A).

IMPORTANT:

To prevent damage to the lift system when lowering header lift linkages without a header or weight box attached to windrower, ensure that float engagement pin is installed in storage hole location and **NOT** in working hole location.

13. Remove pins (A) securing the lift linkages to the weight box, and retain the pins for attaching the header to the windrower.
14. Disengage the lift cylinder safety props. For instructions, refer to [4.4.1 Engaging and Disengaging Header Safety Props](#), page 196.
15. Start the engine, lower weight box onto blocks, and back away.
16. Attach the header to the windrower. For instructions, refer to [4.5 Attaching and Detaching Headers](#), page 218.
17. Convert header into field position. Refer to header operator's manual for procedure.

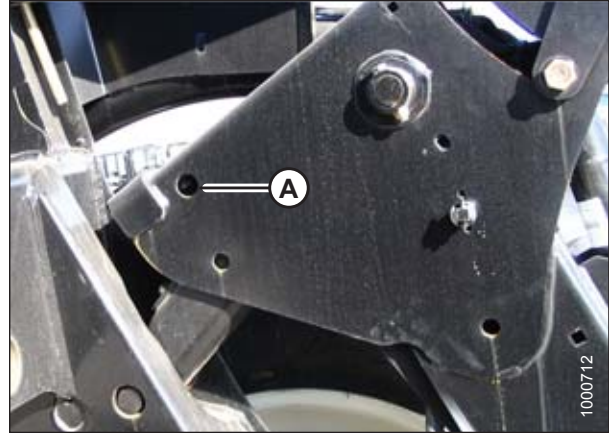

Figure 4.49: Lift Arms

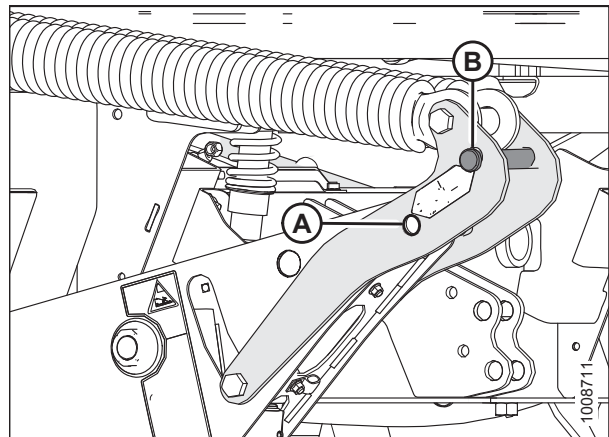

Figure 4.50: Float Pins



Figure 4.51: Weight Box

OPERATION

18. Start the engine and lower the header to the ground. Continue to retract lift cylinders so that member (A) lifts off of link (B).
19. Remove temporary lift pins (C) from lift arms and install pins into storage holes in weight box.
20. Before operating the machine, double-check that all pins are secure and that all safety equipment is installed and fully functional.
21. Proceed with header operation.

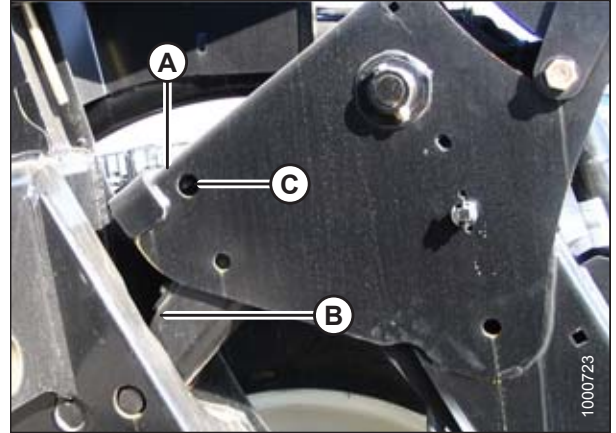

Figure 4.52: Lift Arms

Attaching Header Transport Hitch to Header

Attach header transport hitch to header as follows:

1. Position end (A) of the aft section onto front wheel hook (B).
 2. Push down until latch (C) captures the end (A).
 3. Secure latch (C) with clevis pin (D).
-
4. Remove the L-pin from end (A) of aft section (if installed).

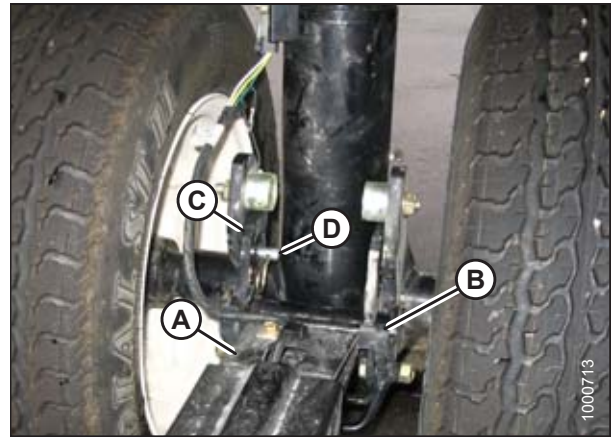

Figure 4.53: Transport Hitch

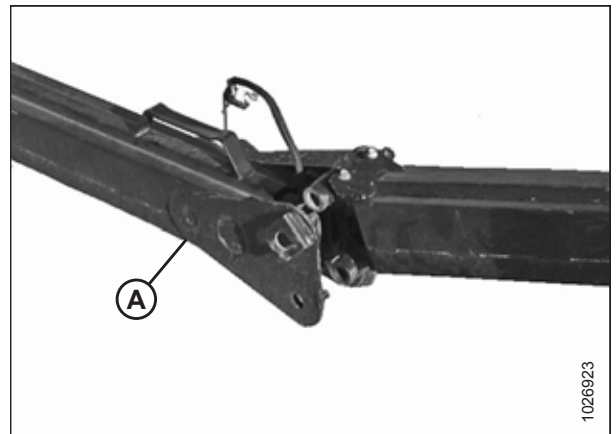

Figure 4.54: Transport Hitch

OPERATION

5. Position end (B) of the forward section into end (A) of the aft section. Lower forward section into aft section.

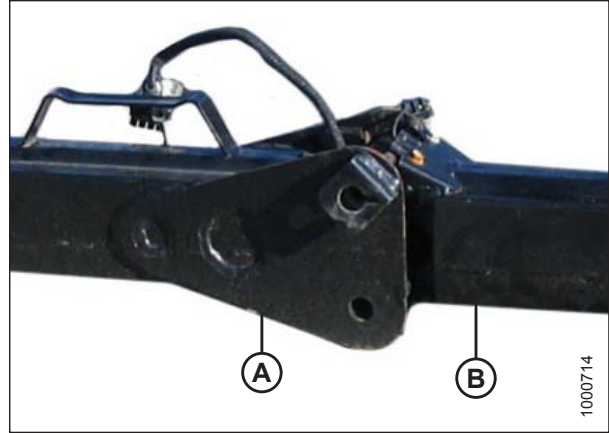

Figure 4.55: Transport Hitch

6. Fully insert L-pin (A) in upper hole and turn pin to lock it. Secure with ring pin (B).
7. Make electrical connection at the joint (C).

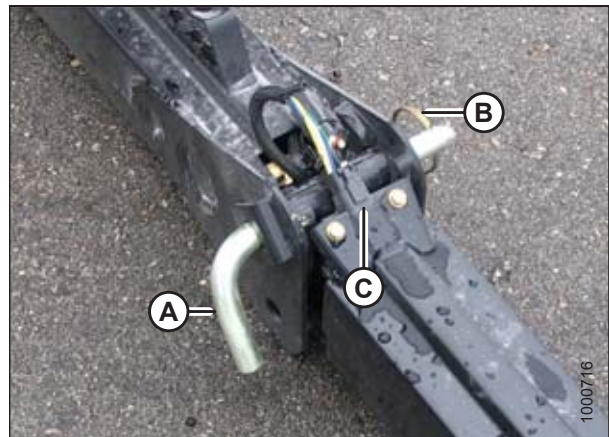

Figure 4.56: Transport Hitch

8. Make the electrical connection at the header wheel (A).



Figure 4.57: Header Transport Wheel

OPERATION

IMPORTANT:

To prevent damage to the lift system when lowering header lift linkages without a header or weight box attached to windrower, ensure that float engagement pin is installed in storage location (B) and **NOT** installed at hole location (A).

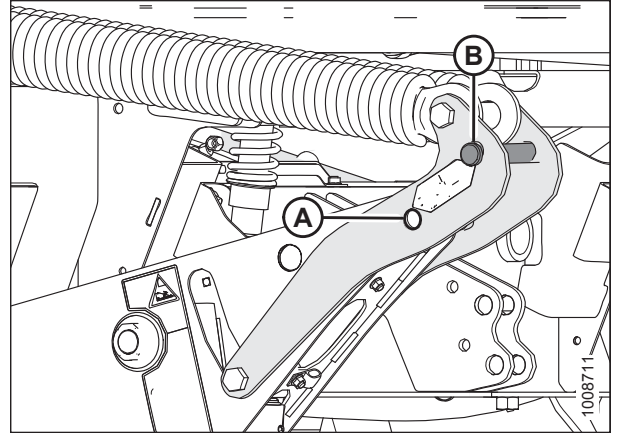

Figure 4.58: Lift Linkage

9. Drive windrower so that windrower lift arms are positioned into the weight box pockets.
10. Raise lift arms slightly, install locking pins (A) into pockets, and through windrower header lift linkages. Secure with a hairpin.

NOTE:

Pins (A) were previously removed from the header lift linkage lower end.



Figure 4.59: Windrower Lift Linkage

11. Route weight box harness (A) to the electrical connector at the left side lift linkage and connect harness to connector on windrower (B).
12. Raise lift arms fully.
13. Shut engine OFF, and remove key from ignition.



Figure 4.60: Weight Box

OPERATION

14. Move float pins from storage location (A) to engaged position (B).

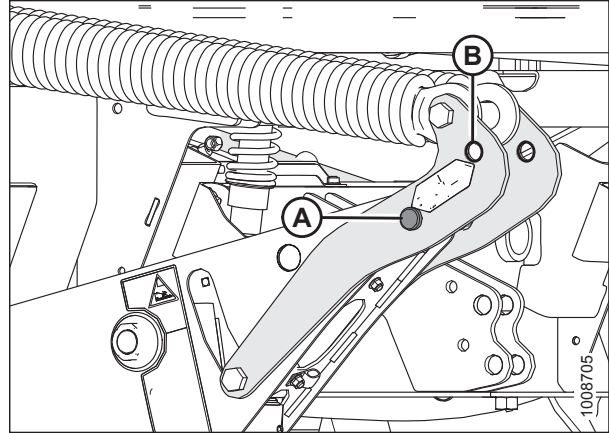

Figure 4.61: Lift Linkage

15. Start engine and press HEADER DOWN switch (A) on ground speed lever (GSL) to lower lift arms until the rear of the arms lift away from the linkage.

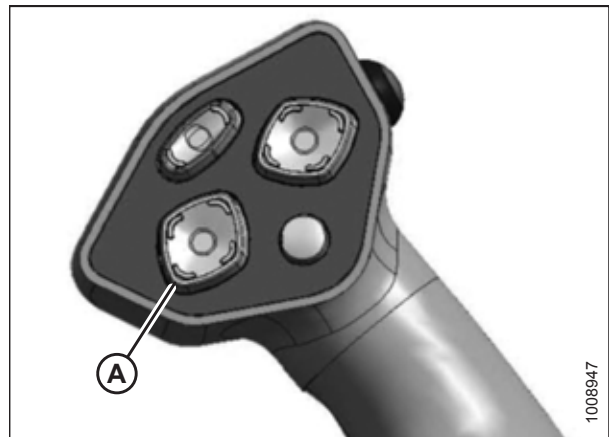

Figure 4.62: GSL

16. Attach slow speed transport hitch to the weight box tongue with drawbar pin. Secure using lynch pin (A). Attach safety chain (B).
17. Connect hitch harness (C) to electrical socket at front of weight box.

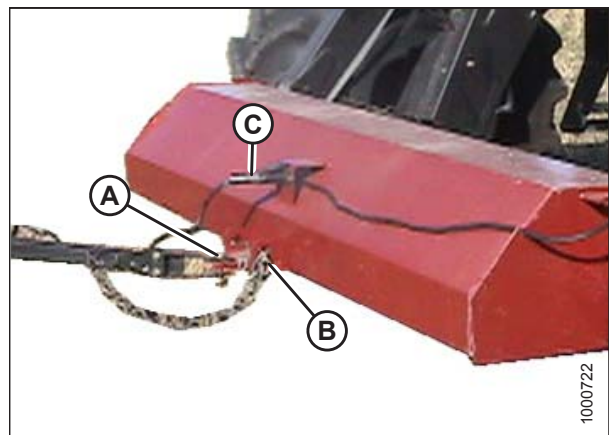

Figure 4.63: Weight Box

OPERATION

18. Remove the temporary lift pins (A) (should be loose in lift arm) and place into storage holes on weight box.

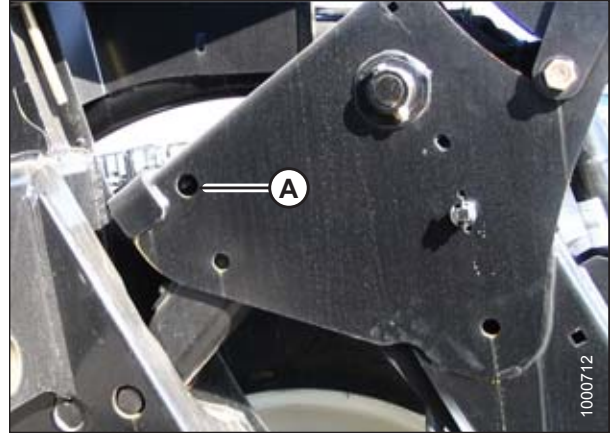

Figure 4.64: Lift Arms

Towing the Windrower – Emergency

Towing the windrower is **NOT** recommended. If the windrower gets stuck, or must be towed onto a truck or trailer, follow these steps:

IMPORTANT:

- **NEVER** attempt to start the windrower by towing it. Serious damage to the final drives may occur.
- Failure to disengage final drives before towing will result in serious transmission damage.
- Only tow the windrower for a short distance, on level ground, and at slow speed.

DANGER

Uncontrolled heavy equipment. With final drives disengaged (turned inward), brakes and steering do NOT work. After towing, place blocks under front and rear wheels to prevent uncontrolled movement.

1. Before towing the vehicle, disengage the final drives. For instructions, refer to [Engaging and Disengaging Final Drives, page 194](#).
2. Use attachment point (A) to tow if windrower gets stuck, or when pulling onto a truck or trailer for transport.
3. When towing is complete, place blocks under front and rear wheels to prevent uncontrolled movement.
4. Engage final drives. For instructions, refer to [Engaging and Disengaging Final Drives, page 194](#).

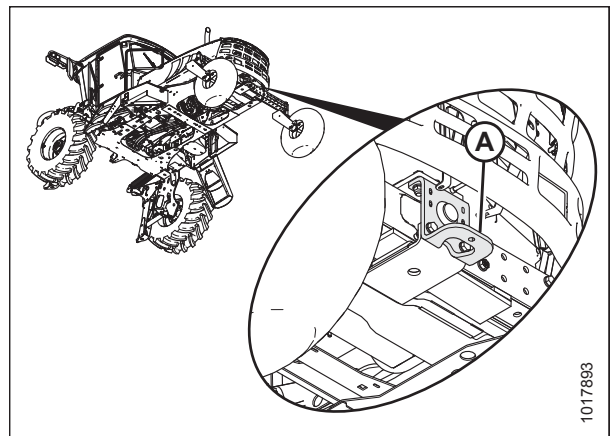

Figure 4.65: Emergency Towing

OPERATION

Engaging and Disengaging Final Drives

Disengage and engage final drives as follows:

WARNING

Park on a flat, level surface, and chock wheels to prevent unexpected rolling when disengaging final drive.

1. Remove two bolts (A) at the center of the drive wheel.
2. Remove cap (B) and flip it over so that the convex side faces in. The cap presses a pin that disengages the gearbox.
3. Reinstall bolts (A) to secure cap (B).
4. Repeat the previous steps on the other drive wheel.
5. After towing, reverse cap (B) to engage the final drives. Be sure the pin at the center of the wheel pops out to engage the drive.

NOTE:

Engaging the final drives may require rocking the wheels slightly.

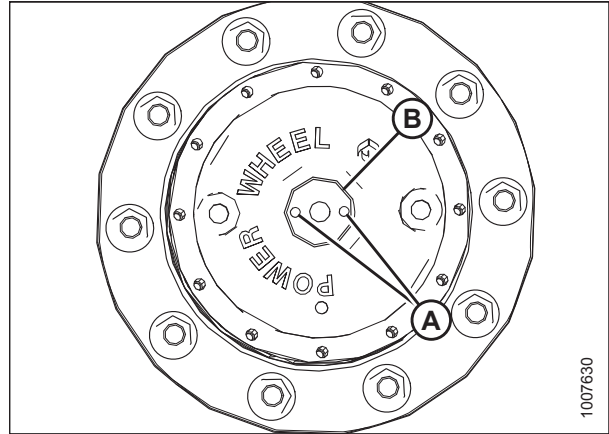

Figure 4.66: Final Drives

4.3.9 Storing the Windrower

At the end of each operating season, you need to store your windrower properly.



WARNING

Never use gasoline, naphtha, or any volatile material for cleaning purposes. These materials are toxic and can be flammable.



CAUTION

Never operate engine in a closed building. Proper ventilation is required to avoid exhaust gas hazards.



CAUTION

Remember when working around storage batteries that all of the exposed metal parts are live. Never lay a metal object across the terminals because a spark and short circuit will result.

1. Clean the windrower thoroughly.
2. Store the windrower in a dry protected place.
3. Remove and store your batteries properly. For instructions, refer to [Removing Batteries, page 387](#).
4. Charge batteries and store them in a cool, dry area in an upright position. Do **NOT** stack batteries on top of each other unless they are in cartons.
5. If stored outside, cover the windrower with a waterproof tarpaulin or other protective material. This will protect the switches, instruments, tires, etc. from inclement weather.
6. If no cover is available, seal the air cleaner intake and exhaust pipe with plastic bags and/or waterproof tape.
7. If possible, store the windrower on blocks to take weight off the tires. If blocking up the machine is not possible, increase tire pressure by 25% for storage. Adjust to recommended operating pressure before next use.
8. Repaint all worn or chipped painted surfaces to prevent rust.
9. Lubricate the windrower thoroughly, leaving excess grease on fittings to keep moisture out of bearings. Apply grease to exposed threads and sliding surfaces of components.
10. Check for worn components and repair. Tighten loose hardware and replace any missing hardware. For torque values, refer to [8.1 Recommended Torques, page 467](#).
11. Check for broken components and order replacements from your Dealer. Attending to these items right away will save time and effort at beginning of the next season.
12. Add approved rust inhibitor to the engine oil in accordance with the manufacturer's instructions. Run the engine to operating temperature to mix inhibitor with oil, unless otherwise specified.
13. To prevent condensation, fill the hydraulic oil reservoir to the filler neck with approved hydraulic system oil. For instructions, refer to [5.10.1 Checking and Filling Hydraulic Oil, page 415](#).
14. Test the engine coolant antifreeze concentration to ensure it is sufficient to protect the engine against lowest expected temperature.

4.4 Operating with a Header

The M155 Self-Propelled Windrower is designed to operate with a MacDon A Series Auger Header, R or R1 Series Rotary Disc Header, or D or D1 Series Draper Header with or without a Hay Conditioner.

This section describes the attachment and detachment procedures and operating instructions for these header types.

4.4.1 Engaging and Disengaging Header Safety Props

Safety props are located on both header lift cylinders on the windrower. Follow these steps to engage or disengage the header safety props:

DANGER

To avoid bodily injury from fall of raised header, always engage safety props when working on or around raised header, and before going under header for any reason.

Engage safety props as follows:

1. Start engine and press HEADER UP switch (A) to raise header to maximum height.
2. Rephase cylinders if one end of the header does not raise fully. If rephasing is required, proceed as follows:
 - a. Press and hold the HEADER UP switch (A) until both cylinders stop moving.
 - b. Continue to hold the switch for 3–4 seconds. Cylinders are now phased.

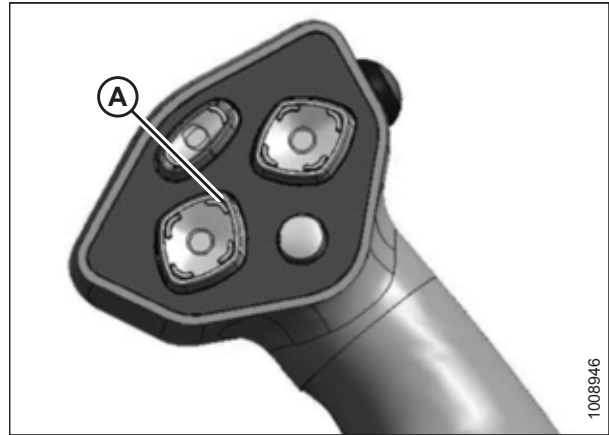

Figure 4.67: Ground Speed Lever (GSL)

OPERATION

3. Pull lever (A) and rotate it toward the header to lower safety prop (B) onto the cylinder. Repeat for the opposite cylinder.

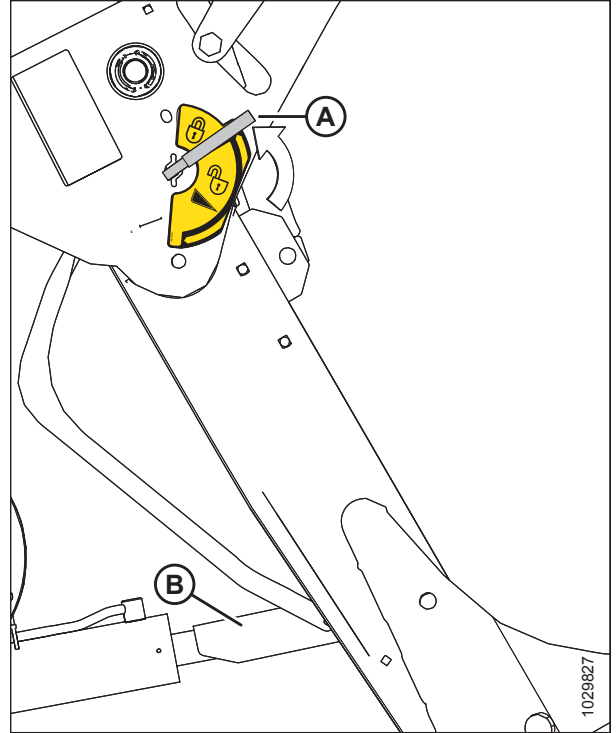

Figure 4.68: Safety Prop

Disengage safety props as follows:

WARNING

To avoid bodily injury or death from unexpected startup of the machine, always stop the engine and remove the key from the ignition before leaving the operator's seat for any reason.

1. Turn lever (A) away from header to raise safety prop until lever locks into vertical position. Repeat for opposite cylinder.
2. Start the engine, choose a level area, and lower the header to the ground.
3. Shut down the engine, and remove the key from the ignition.

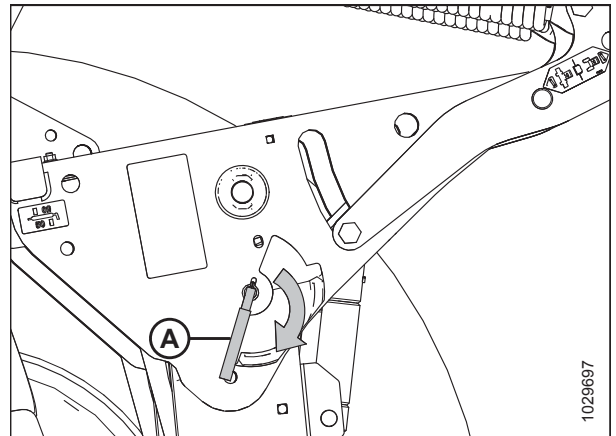

Figure 4.69: Safety Prop

4.4.2 Using Header Float

The header float feature allows the header to closely follow ground contours and to respond quickly to sudden changes or obstacles. The float setting is ideal when the cutterbar is on the ground with minimal bouncing, scooping, or pushing soil.

IMPORTANT:

- Set header float as light as possible—without excessive bouncing—to avoid frequent breakage of knife components, scooping soil, or soil build-up at the cutterbar in wet conditions.
- Avoid excessive bouncing (resulting in a ragged cut) by operating at a slower ground speed when the float setting is light.
- Before setting header float, install header options (upper cross auger, skid shoes, transport kit, etc.). If the Slow Speed Transport (SST) tow bar will be stored on the header during operation, set float with tow bar in place.
- Adjust the float when adding or removing optional attachments that affect the weight of the header.

Float Operating Guidelines

When working with the cutterbar on the ground:

- Set center-link to mid-range position (5.0 on cab display module [CDM]). For instructions, refer to [4.4.5 Adjusting Header Angle, page 208](#).
- When operating at the flattest header angle, minimize scooping rocks by adjusting the header skid shoes downward to raise guards.
- To minimize pushing soil, adjust header height or adjust header angle.

When working with the cutterbar off the ground (draper header only):

- Set center-link to mid-range position (5.0 on CDM). For instructions, refer to [4.4.5 Adjusting Header Angle, page 208](#).
- Balance the amount of header weight carried by the float and stabilizer wheels. Refer to your draper header operator's manual.
- Use the CDM controls to automatically maintain cutting height. For instructions, refer to [4.4.6 Controlling Cutting Height, page 211](#).

Checking Float

The windrower is equipped with primary (coarse) and secondary (fine) float adjustment systems. The primary adjustment uses drawbolts to change the tension on the springs in the lift linkages. The secondary adjustment uses hydraulic cylinders to change the spring tension.

Figure 4.70: Cab Display Module (CDM) Float Adjustment



A - CDM Display
D - Header Tilt Down

B - Left Float Adjustment
E - Header Lower

C - Right Float Adjustment
F - Header Tilt Up

Check header float as follows:

WARNING

To avoid bodily injury or death from unexpected startup of the machine, always stop the engine and remove the key from the ignition before leaving the operator’s seat for any reason.

CAUTION

Check to be sure all bystanders have cleared the area.

1. Start the engine.
2. Lower header to ground.
3. Using HEADER TILT switches (D) and (F), set center-link to mid-range position (5.0 on CDM [A]).

NOTE:

If equipped with the optional draper header reel drive (MD #B5496), adjust reel fore-aft to your normal operating position.

4. Using HEADER DOWN switch (E), lower header fully with lift cylinders fully retracted.

OPERATION

5. Set left (B) and right (C) float fine adjustments on CDM to approximately 5.0 as follows:
 - a. Using FLOAT SELECTOR switch (B), push + to increase float or – to decrease float on the left side of header. CDM display (A) will show selected float for the left side, for example, (5.0 L FLOAT R XX.X).
 - b. Repeat for the right side float with switch (C). Display will show float for both sides, for example, (5.0 L FLOAT R 5.0).
6. Shut down the engine, and remove the key from the ignition.
7. Grasp the end of the header and lift. The force to lift should be as noted in the following table and should be approximately the same at both ends.

Header	Force Required to Lift Header at the Ends with Lift Cylinder Fully Retracted
Auger	335–380 N (75–85 lbf)
Rotary disc	426–471 N (95–105 lbf)
Draper	335–380 N (75–85 lbf) with stabilizer/transport wheels raised (if equipped)

Adjusting Float Using Drawbolts

Coarse float adjustment is done using the drawbolts located on either side of the windrower.

WARNING

To avoid bodily injury or death from unexpected startup of the machine, always stop the engine and remove the key from the ignition before leaving the operator's seat for any reason.

CAUTION

Check to be sure all bystanders have cleared the area.

1. Start the engine.
2. Using HEADER UP switch (A) on the ground speed lever (GSL), raise the header fully.
3. Shut down the engine, and remove the key.



Figure 4.71: GSL

OPERATION

4. Turn drawbolt (A) clockwise to increase float (makes header lighter) or counterclockwise to decrease float (makes header heavier).
5. Recheck the header float.

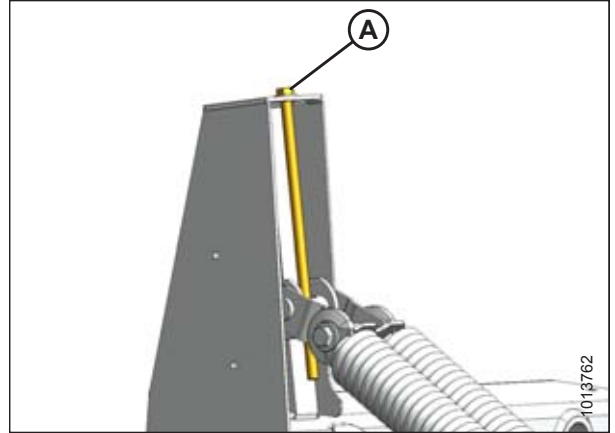

Figure 4.72: Header Float Adjustment

Float Options

For draper headers without the deck shift option, auger headers, and rotary disc headers, the float disc can be preprogrammed for three types of windrowing conditions.

Example:

- Position 1: Border
- Position 2: Normal
- Position 3: Rocky

Set float presets as follows:

1. Engage header.
2. Push FLOAT PRESET SWITCH (A) to Position 1 (B).

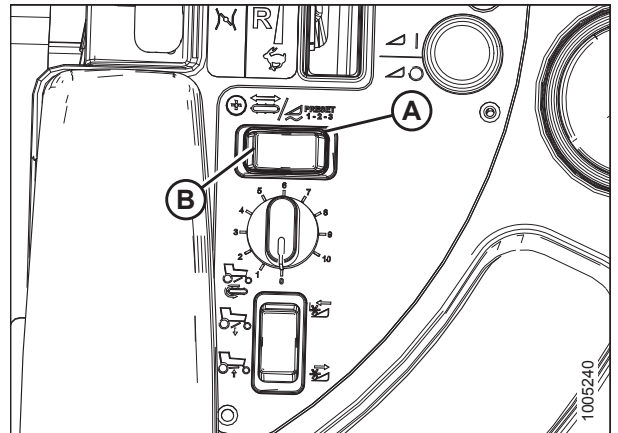

Figure 4.73: Float Preset Switch

OPERATION

Figure 4.74: Cab Display Module (CDM) Float Adjustment



A - CDM Display
D - Header Tilt Down

B - Left Float Adjustment
E - Header Lower

C - Right Float Adjustment
F - Header Tilt Up

- Using HEADER TILT switches (D) and (F), set center-link to mid-range position (5.0 on CDM [A]).

NOTE:

If equipped with the optional draper header reel drive (MD #B5496), adjust reel fore-aft to your normal operating position.

- Using HEADER DOWN switch (E), lower header fully with lift cylinders fully retracted.
- Set left (B) and right (C) float fine adjustments on CDM to approximately 5.0 as follows:
 - Using FLOAT SELECTOR switch (B), push + to increase float or – to decrease float on the left side of header. CDM display (A) will show selected float for the left side, for example, (5.0 L FLOAT R XX.X).
 - Repeat for the right side float with switch (C). Display will show float for both sides, for example, (5.0 L FLOAT R 5.0).

OPERATION

6. Select a second preset with the FLOAT PRESET 2 SWITCH (C).
7. Repeat Steps 1, page 201 and 2, page 201 to set the float.
8. Select a third preset with the FLOAT PRESET 3 SWITCH (D).
9. Repeat Steps 1, page 201 and 2, page 201 to set the float.

NOTE:

For draper headers with the deck shift option, the float can be preprogrammed to compensate for weight distribution when the decks are shifted. Refer to *Setting Float Options with Deck Shift, page 301*.

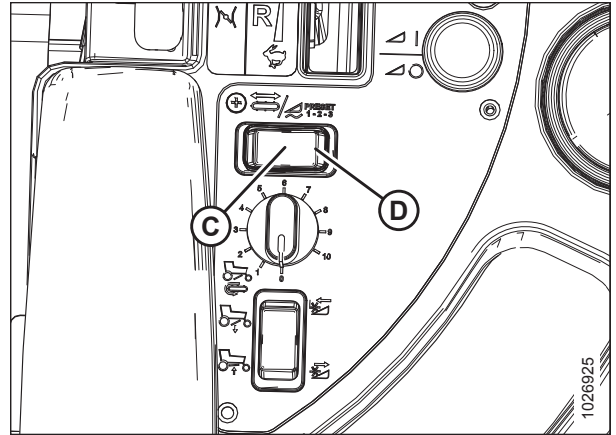

Figure 4.75: Float Preset Switch

4.4.3 Levelling the Header

The windrower linkages are factory-set to provide the proper level for the header and should not normally require adjustment.

WARNING

To avoid bodily injury or death from unexpected startup of the machine, always stop the engine and remove the key from the ignition before leaving the operator's seat for any reason.

If the header is not level, check the windrower tire pressures before adjusting the levelling linkages.

NOTE:

The float springs are **NOT** used to level the header.

To level the header, follow these steps:

1. Place float pins in locked out location (A).

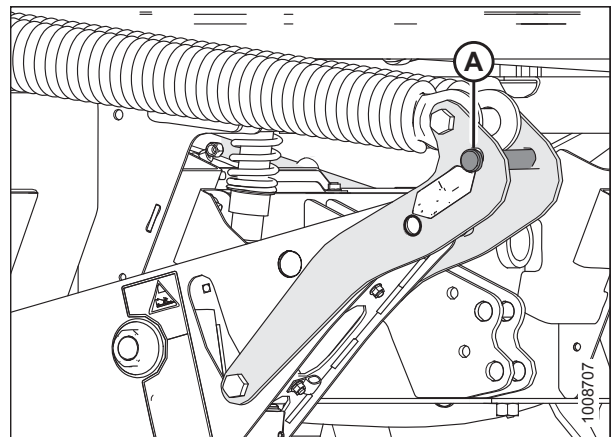

Figure 4.76: Float Pins – Disengaged

OPERATION

2. Park windrower on level ground.
3. Raise header fully with HEADER UP button (A) and hold momentarily to allow lift cylinders to rephase.



Figure 4.77: Ground Speed Lever (GSL)

4. Set header approximately 150 mm (6 in.) off ground and check that member (A) is against link (B).
5. Shut down the engine, and remove the key from the ignition.
6. Measure distance to ground at both ends of header and determine the end that is higher.
7. If adjustment is necessary, start the engine and raise the header fully. Turn off the engine and remove the key from the ignition.



Figure 4.78: Lift Linkage

8. Move float pins to engaged position (A).

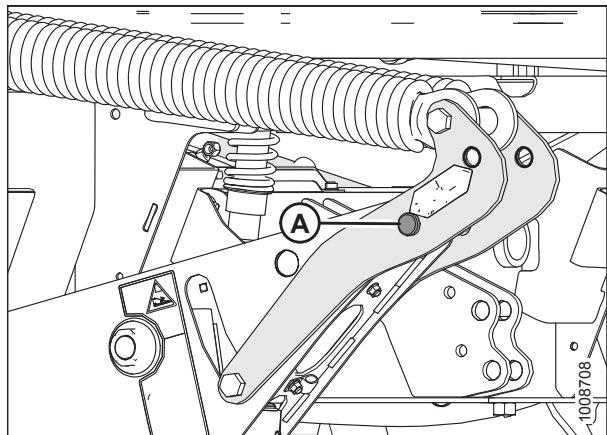

Figure 4.79: Float Pins – Engaged

OPERATION

9. Start the engine and lower the header onto the ground until member (A) lifts off link (B) on both sides.
10. Shut down the engine, and remove the key from the ignition.

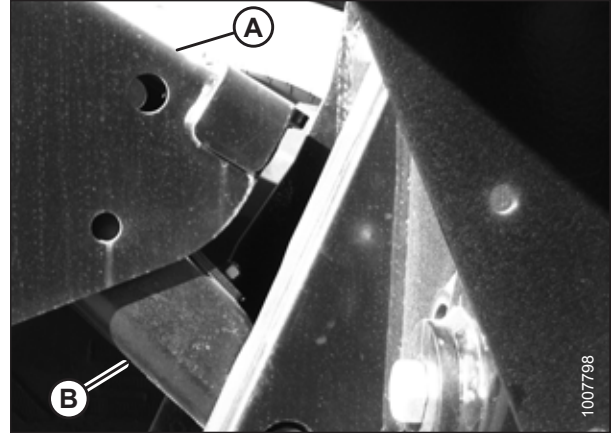

Figure 4.80: Lift Linkage

11. On the high side of the linkage, remove nut, washer, and bolt (A) that attaches shims (B) to the link.
12. Remove one or both shims (B), and reinstall the hardware (A).

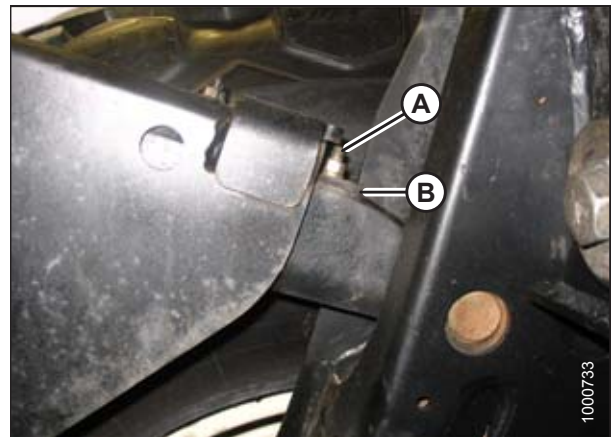

Figure 4.81: Lift Linkage

13. Start the engine and raise the header fully.
14. Stop the engine and remove the key from the ignition.
15. Move float pins to disengaged position.
16. Start the engine and set the header approximately 150 mm (6 in.) off the ground.
17. Check that member (A) is against link (B).
18. Shut down the engine, and remove the key from the ignition.
19. Measure distance to ground at both ends of the header.
20. If additional levelling is required, repeat Steps 7, page 204 to 10, page 205 and install the removed shim on the opposite linkage.



Figure 4.82: Lift Linkage

NOTE:

If required, additional shims are available from your Dealer.

OPERATION

21. Once the header is level, return float pins to their engaged position (A).

NOTE:

Float does **NOT** require adjustment after levelling the header.

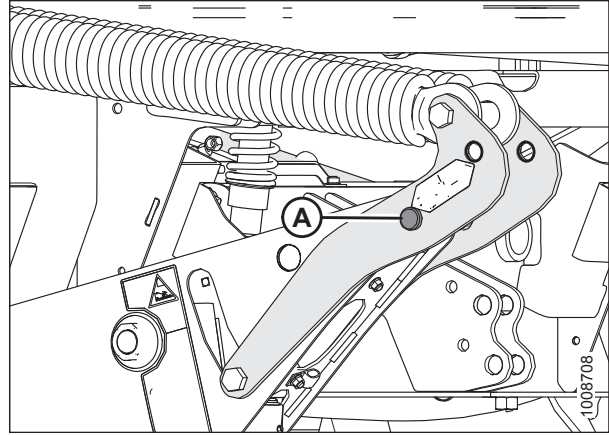

Figure 4.83: Float Pins – Engaged

4.4.4 Header Drive

All header controls are conveniently located on the operator's console and on the ground speed lever (GSL) handle.

NOTE:

Some controls are optional equipment and may not be present in your unit. Some controls may be installed, but will be nonfunctional for certain headers.

Engaging and Disengaging the Header

IMPORTANT:

Always move throttle lever back to idle before engaging header drive. Do **NOT** engage header with engine at full rpm.

CAUTION

Check to be sure all bystanders have cleared the area.

1. **To engage header:**
 - a. Move throttle (A) to adjust engine speed to idle.
 - b. Push the center down and pull up HEADER DRIVE switch (B) to engage header drive. A slight delay between switch ON and operating speed is normal.
2. **To disengage header:**
 - a. Push HEADER DRIVE switch (B) down to disengage header drive.



Figure 4.84: Operator Console

OPERATION

Reversing the Header

NOTE:

The optional hydraulic reversing kit must be installed.

IMPORTANT:

Hose plumbing to the reverser block is specific to the header type. To prevent damage to the reel on D and D1 Series headers, refer to the reverser kit installation instruction MD #169213 when switching from an auger header to a draper header on the same windrower.

- Reverses knife and conditioner on D and D1 Series draper headers.
- Reverses reel, auger, knife, and conditioner on A Series auger headers.

Reverse the header as follows:

1. Push down and hold HEADER DRIVE REVERSE button (A) and pull up the HEADER DRIVE switch (B). CDM will display HEADER REVERSE.
2. Release REVERSE button (A) to stop header.
3. Push down the HEADER DRIVE switch (B) to OFF, so that it can be restarted.

NOTE:

To engage header drive, push down, and pull up HEADER DRIVE knob.



Figure 4.85: Operator Console

4.4.5 Adjusting Header Angle

Header angle is defined as the angle between the ground and the drapers/cutterbar. It is adjustable to accommodate crop conditions and/or soil type.

Refer to the appropriate header operator's manual for the range of adjustment and recommended settings for your particular header.

The header angle can be hydraulically adjusted from the cab without shutting down the windrower when the windrower is equipped with the hydraulic center-link. A readout on the cab display module (CDM) allows you to establish settings for each crop condition.

IMPORTANT:

- Changing header angle will affect float slightly because it has the effect of making the header lighter or heavier.
- To prevent excessive guard breakage when conditions are not suited to heavier float (e.g., rocky or wet), do **NOT** use the TILT CONTROL. Instead, use the HEADER HEIGHT switch.

Figure 4.86: Operator Console



A - Program Button
D - Header Tilt Up

B - Display
E - Display Selector

C - Header Tilt Down

Hydraulic link (optional)

Adjust the header angle as follows:

- To decrease (flatten) header angle, operate HEADER TILT UP switch (D) on ground speed lever (GSL) handle so that cylinder retracts. The CDM display will show a reading on the lower line of decreasing value between 00.0 and 10.0.
- To increase (steepen) header angle, operate HEADER TILT DOWN switch (C) on the GSL handle so the cylinder extends. The CDM display will show a reading on the lower line of increasing value between 00.0 and 10.0.

NOTE:

The HEADER TILT switch can be locked out to prevent inadvertent header angle changes when pressing the HEADER HEIGHT control switches. For instructions, refer to [Activating the Header Tilt Control Lockout, page 112](#).

OPERATION

Mechanical link

Adjust header angle as follows:

1. Lower the header to the ground.
2. Shut down the engine, and remove the key from the ignition.
3. Loosen nut (A) on center-link.
 - To increase (steepen) angle, rotate barrel (B) to lengthen center-link.
 - To decrease (flatten) angle, rotate barrel (B) to shorten center-link.
4. Tighten plate nut (A) with a slight tap of a hammer.

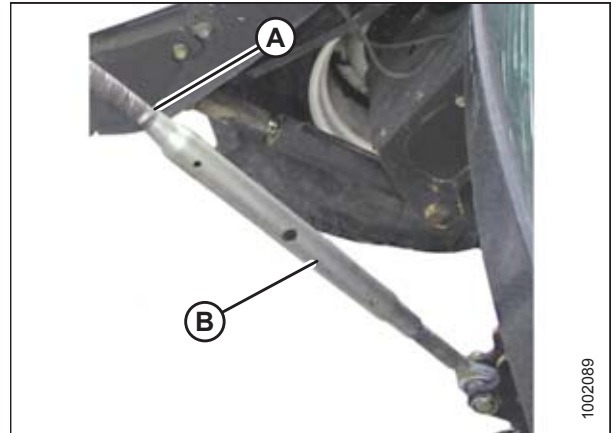

Figure 4.87: Mechanical Center-Link

Checking Self-Locking Center-Link Hook

Periodically check the operation of the hook locking mechanism and ensure that it is working properly as follows:

1. If header is attached to windrower, disconnect center-link hook from header by pulling up on handle (A) to release the locking device and then lifting the hook off the header pin.

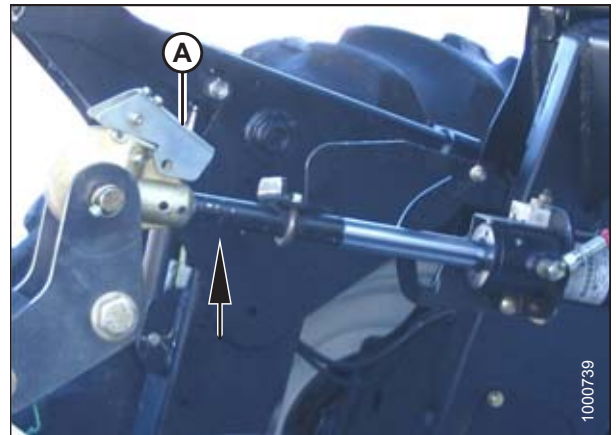

Figure 4.88: Center-Link

OPERATION

2. Lower handle (A) into the **LOCK** position.
3. Push up on lock pin (B) only. Handle should catch on casting and pin should **NOT** lift.

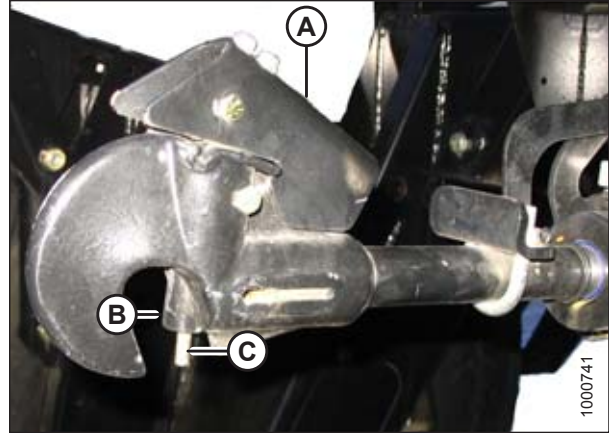

Figure 4.89: Center-Link Hook

A - Handle

B - Lock Pin

C - Actuator Rod

4. Push up on actuator rod and lock pin should lift with the handle.



Figure 4.90: Center-Link Hook

4.4.6 Controlling Cutting Height

Figure 4.91: Operator Console



Cutting height is adjusted by raising or lowering the header with the HEADER UP (B) or HEADER DOWN (C) switches on the ground speed lever (GSL).

The cab display module (CDM) indicates header height with a reading on the DISPLAY (A) lower line between 00.0 and 10.0, with 00.0 being on the ground.

Use DISPLAY SELECTOR switch (D) to display the current setting.

4.4.7 Return to Cut

The monitoring system will assist you in maintaining the desired cutting height with the RETURN TO CUT feature. This feature can be turned OFF or ON with a switch on the cab display module (CDM).

The return to cut (RTC) feature provides preset cutting height and tilt angle settings for the header.

If desired, the CDM can be programmed so that only the cutting height feature is active.

The AUTO RAISE HEIGHT feature allows you to raise the header to a preselected height while in the RETURN TO CUT mode. Refer to [Programming the Auto Raise Height Feature, page 214](#).

Refer to the following for RTC programming and operating procedures:

- [Programming the Return to Cut Feature, page 212](#)
- [Using the Return to Cut Feature, page 213](#)

Programming the Return to Cut Feature

Figure 4.92: Operator Console



Program the return to cut (RTC) feature as follows:

CAUTION

Check to be sure all bystanders have cleared the area.

1. Start and windrower and engage the header.
2. Set RETURN TO CUT switch (A) to OFF (indicator light is OFF).
3. Adjust the header to the desired cutting height with the HEADER UP (B) or HEADER DOWN (C) switches on the ground speed lever (GSL). The cab display module (CDM) displays between **00.0** and **10.0** at location (D).
4. Adjust the header angle with the HEADER TILT UP (E) or HEADER TILT DOWN (F) switches on the GSL. The CDM displays between **00.0** and **10.0**. This step is not required when height only has been preselected.
5. Press the RETURN TO CUT switch (A) on the CDM. The indicator light will illuminate and the settings are now programmed into the windrower control module (WCM).

Using the Return to Cut Feature

Figure 4.93: Operator Console



A - Return to Cut
D - Display

B - Header Up
E - Header Tilt Up

C - Header Down
F - Header Tilt Down

Use the return to cut feature as follows:

IMPORTANT:

Ensure the header is engaged and the RETURN TO CUT switch (A) is illuminated.

NOTE:

The header can be raised or lowered by **PRESSING AND HOLDING** the HEADER UP (B) or HEADER DOWN (C) switches on the ground speed lever (GSL).

1. If header is above the preset cutting height, **MOMENTARILY PRESS** HEADER DOWN switch (C) and the header will return to preset height.
2. If the header is below the preset height, **PRESS AND HOLD** the HEADER UP (B) switch to raise the header. Release switch to stop header. Alarm will sound when header rises past the preset height.
3. If the header angle changes, double-click (two clicks within 0.5 seconds) the HEADER TILT UP (E) or HEADER TILT DOWN switch (F) and the header will return to the preset angle.

NOTE:

If the header cannot return to the preset height or angle within 30 seconds, the return to cut feature will deactivate to prevent the hydraulic oil from overheating. Push the RETURN TO CUT switch (A) to reactivate.

4.4.8 Auto Raise Height

The header can be raised to a preset height by enabling the auto raise height feature in the cab display module (CDM).

Refer to the following topics:

- [Programming the Auto Raise Height Feature, page 214](#)
- [Using the Auto Raise Height Feature, page 215](#)

Programming the Auto Raise Height Feature

Figure 4.94: Operator Console



A - Return to Cut
E - Left Arrow

B - Program
F - Header Up

C - Select
G - Header Down

D - Right Arrow

Program the auto raise height feature as follows:

NOTE:

RETURN TO CUT switch (A) can be OFF or ON.

1. Turn ignition ON or run engine.
2. Press PROGRAM (B) and SELECT (C) on cab display module (CDM) to enter programming mode.
3. Press SELECT (C). WINDROWER SETUP? is displayed on upper line.
4. Press right arrow (D), then SELECT. SET KNIFE SPEED? is displayed.
5. Press SELECT (C) until AUTO RAISE HEIGHT is displayed.
6. Press left arrow (E) or right arrow (D) to change value on lower line. Working range is 4.0 to 9.5. At 10.0, the feature is disabled and OFF is displayed.
7. When finished entering desired values, press PROGRAM to exit programming mode.

OPERATION

Using the Auto Raise Height Feature

IMPORTANT:

The windrower must be running with the header engaged at the cutting height and the RETURN TO CUT switch (A) activated.

Use the auto raise height feature as follows:

1. To raise the header to the auto raise height set-point, double-click (two clicks within 0.5 seconds) the HEADER UP switch (B) on the ground speed lever (GSL).

NOTE:

With AUTO RAISE HEIGHT turned ON, the ACRE counter will be disabled when header height greater than preset cutting height.

2. If desired, press HEADER UP switch while header is being raised to disable auto raise height and maintain current height.

NOTE:

With AUTO RAISE HEIGHT turned OFF, the ACRE counter will be disabled when header height value is greater than 9.5. OFF is displayed on the cab display module (CDM).

3. To return the header to the preset cutting height, momentarily press HEADER DOWN switch (C).

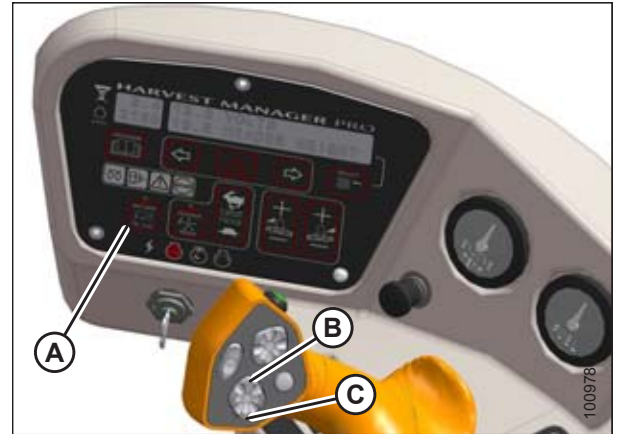

Figure 4.95: Operator's Station

4.4.9 Header Drop Rate

The header should lower gradually when the HEADER DOWN switch is pressed. From full height to ground should take 3–4 seconds.

If the drop rate requires adjustment, refer to [Adjusting Header Drop Rate, page 423](#).

4.4.10 Swath Compressor (Option)

The swath compressor is designed to shape the windrow and anchor it into the stubble behind the header to minimize shelling in ripe conditions. It is available as an optional attachment.

The system is used with MacDon D Series and D1 Series draper headers for cutting canola and replaces the conventional roller-type system. The swath compressor has adjustments for shaping the windrow for optimal drying and protection from wind damage according to crop conditions. The amount of windrow compression is monitored and controlled from the cab with the MacDon Harvest Manager Pro control and monitoring system.

Refer to MacDon Swath Compressor for M Series Windrowers Setup, Operation, and Parts Manual for complete operating and maintenance instructions. The manual is shipped with the swath compressor kit.

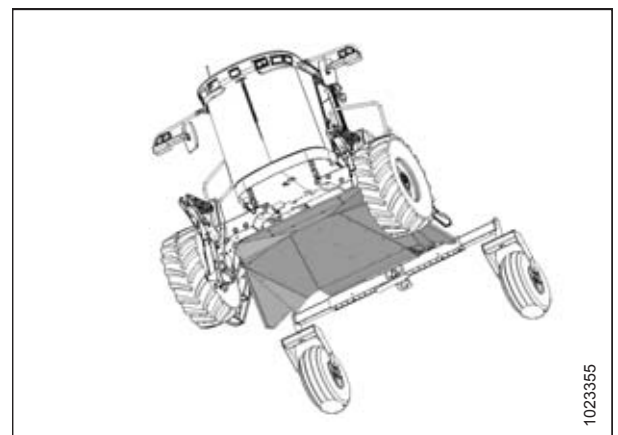

Figure 4.96: Swath Compressor

OPERATION

Using the Swath Compressor

The following topic explains how to use the swath compressor, and describes the automated raise/lower functions.

WARNING

To avoid injury or death from unexpected start-up of machine, always stop the engine and remove the key from the ignition before leaving the operator's seat for any reason.

1. Rotate handle (A) on the left rear support counterclockwise to disengage lock.

IMPORTANT:

- Lock prevents swath compressor from lowering inadvertently when not in use, either due to operator error or loss of hydraulic pressure.
- Engage lock when operating in engine-forward mode.
- Disengage lock before using swath compressor.

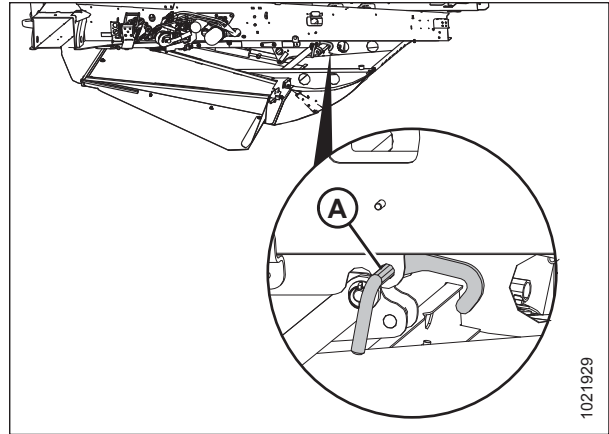

Figure 4.97: Swath Compressor Lock

CAUTION

Check to be sure all bystanders have cleared the area.

2. Start the windrower in cab-forward mode.
3. Press SELECT switch (B) on CDM to show SWATH COMPR HT (A) on display. Height is displayed using an arbitrary scale from 0 to 10. Fully raised is 0.

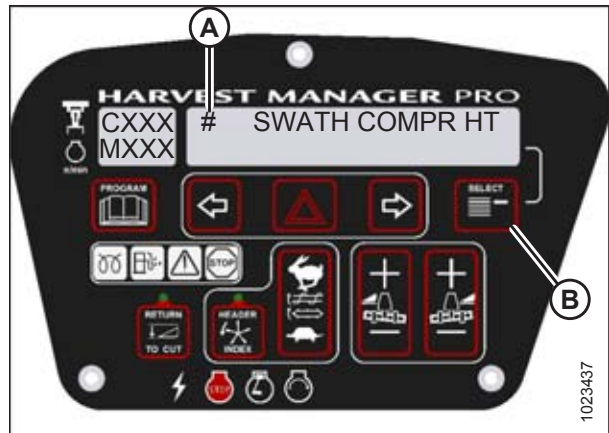

Figure 4.98: CDM Display

OPERATION

- Lower swath compressor by pressing button (A) on the operator's console, and raise it by pressing button (B). The CDM display indicates the position of the swath compressor. Release the switch to stop movement at the desired height.

NOTE:

The last position set with the console buttons becomes the target height. When an adjustment is made, the display shows the target value. The system immediately adjusts to attain the target position. After the last adjustment, the display shows target value for 5 seconds then the display reverts to the previous screen.

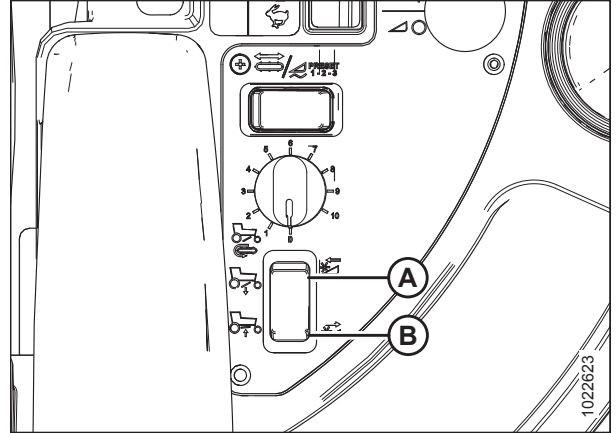

Figure 4.99: Operator's Console

Swath compressor automated functions: header engaged, cab-forward

- When ground speed higher than 2.5 km/h (1.6 mph) is detected, the swath compressor lowers to target height.
- When ground speed transitions through 1.6 km/h (1 mph) during deceleration, the swath compressor is fully raised.
- When ground speed is faster than 1.6 km/h (1 mph) and the HEADER ENGAGE switch is OFF, the swath compressor will fully raise.
- The swath compressor remains inactive in engine-forward mode.

4.5 Attaching and Detaching Headers

4.5.1 Attaching Header Boots

Header boots are required to attach a D Series or D1 Series Draper Header to the windrower. Attach header boots (supplied with header) to windrower lift linkage if not already installed.

IMPORTANT:

To prevent damage to the lift system when lowering header lift linkages without a header or weight box attached to the windrower, ensure the float engagement pin is installed in storage position (B) and **NOT** in engaged position (A).

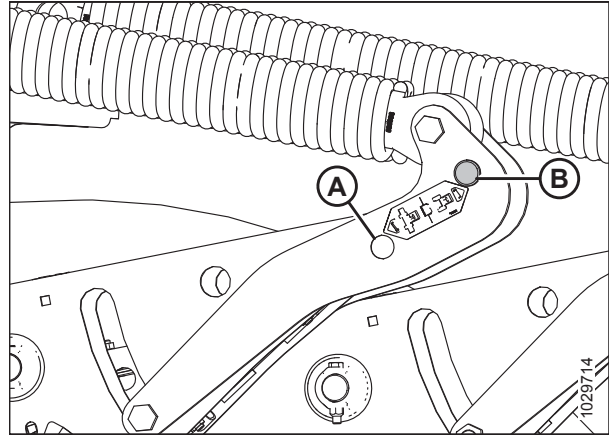

Figure 4.100: Header Float Linkage

1. Remove pin (B) from boot (A).

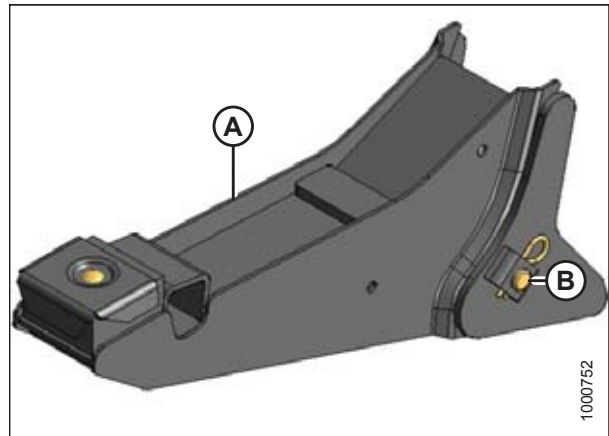

Figure 4.101: Header Boot

2. Position boot (B) onto lift linkage (A) and reinstall pin (C). Pin may be installed from either side of boot.
3. Secure pin (C) with hairpin (D).
4. Repeat for opposite side.

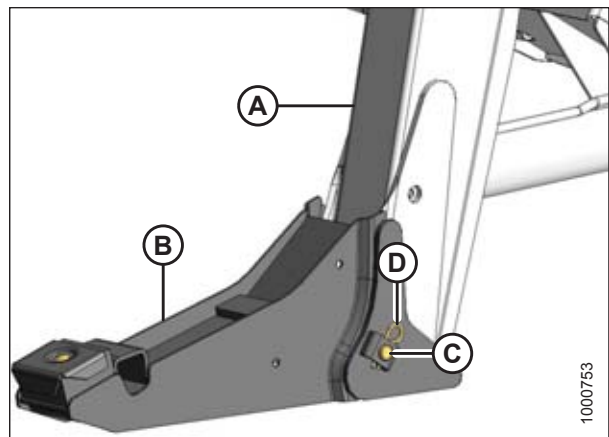

Figure 4.102: Header Boot

4.5.2 Attaching a D Series or D1 Series Header

Refer to the following instructions based on the type of center-link installed on your windrower:

- *Attaching a D Series or D1 Series Draper Header – Hydraulic Center-Link with Optional Self-Alignment, page 219*
- *Attaching a D Series or D1 Series Draper Header – Hydraulic Center-Link without Self-Alignment, page 225*
- *Attaching a D Series or D1 Series Draper Header – Mechanical Center-Link, page 231*

Attaching a D Series or D1 Series Draper Header – Hydraulic Center-Link with Optional Self-Alignment

NOTE:

Draper header boots must be installed onto the windrower lift linkage before starting this procedure. Refer to [4.5.1 Attaching Header Boots, page 218](#).

⚠ WARNING

To avoid bodily injury or death from unexpected startup of the machine, always stop the engine and remove the key from the ignition before leaving the operator’s seat for any reason.

1. Shut down the engine, and remove the key from the ignition.
2. Remove hairpin (A) from pins (B), and remove pins from both header legs.

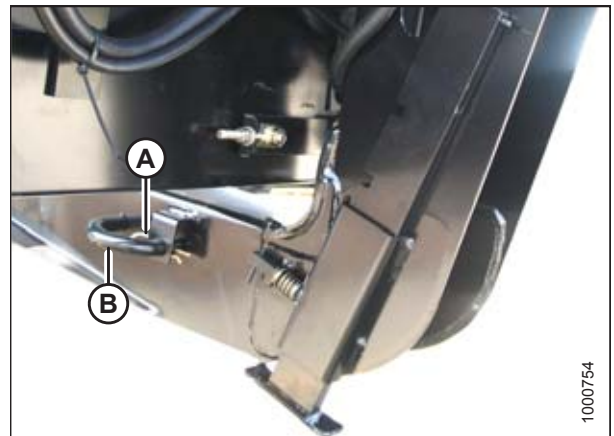

Figure 4.103: Header Leg

⚠ CAUTION

Check to be sure all bystanders have cleared the area.

IMPORTANT:

Before starting engine for the first time the windrower is operated in a season, remove protective cover from exhaust stack.

3. Start the engine and activate HEADER DOWN button (A) on the ground speed lever (GSL) to fully retract header lift cylinders.

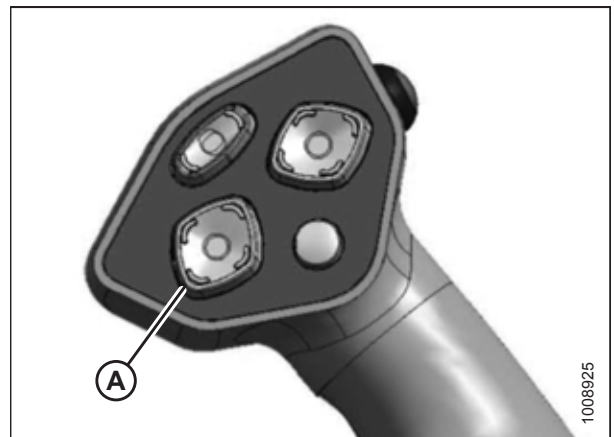

Figure 4.104: Ground Speed Lever

OPERATION

4. Press REEL UP switch (A) on the GSL to raise the center-link until the hook is above the attachment pin on the header.

IMPORTANT:

If the center-link is too low, it may contact the header as the windrower approaches the header for hookup.

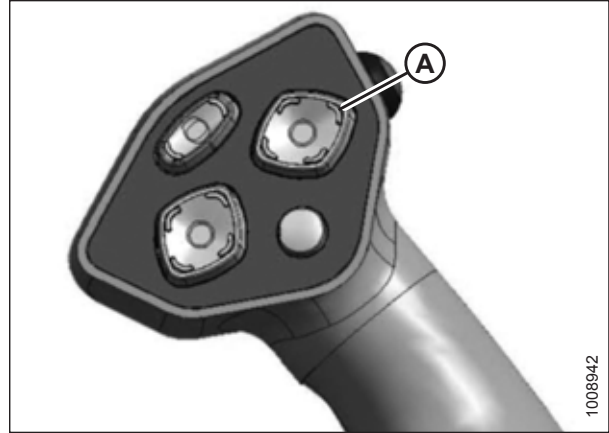

Figure 4.105: Ground Speed Lever

5. Drive the windrower slowly forward until boots (A) enter header legs (B). Continue driving slowly forward until the lift linkages contact the support plates in the header legs and the header nudges forward.
6. Ensure the lift linkages are properly engaged in the header legs and are contacting the support plates.

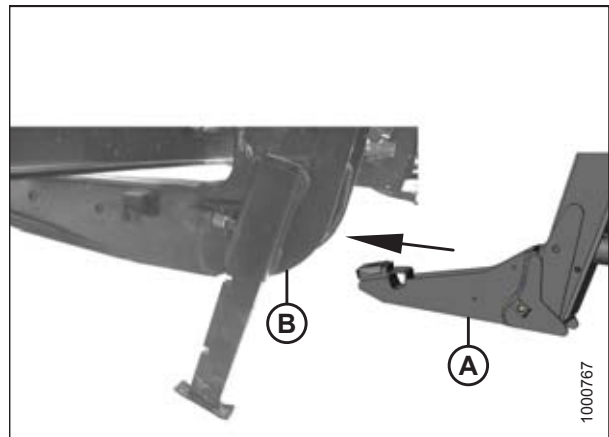

Figure 4.106: Header Leg and Boot

7. Use the following GSL functions to position the center-link hook above the header attachment pin:
 - REEL UP (A) to raise the center-link
 - REEL DOWN (B) to lower the center-link
 - HEADER TILT UP (C) to retract the center-link
 - HEADER TILT DOWN (D) to extend the center-link

IMPORTANT:

Hook release must be down to enable self-locking mechanism. If the release is open (up), manually push it down after hook engages header pin.

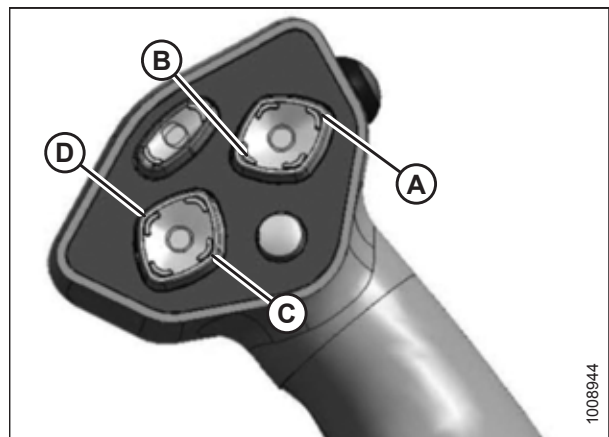

Figure 4.107: Ground Speed Lever

OPERATION

8. Lower center-link (A) onto the header with the REEL DOWN switch on the GSL until it locks into position (hook release [B] is down).
9. Check that center-link (A) is locked onto header by pressing the REEL UP switch on the GSL.

CAUTION

Check to be sure all bystanders have cleared the area.

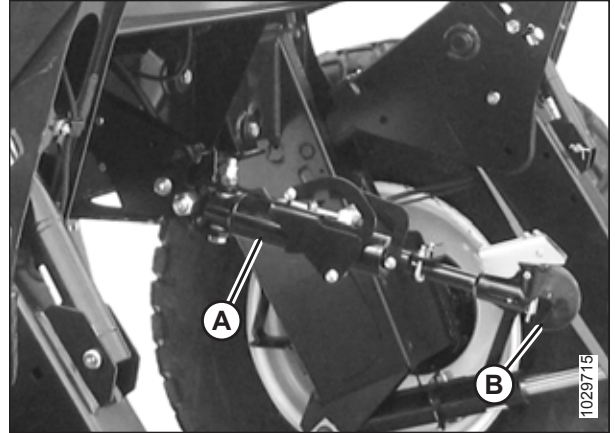

Figure 4.108: Hydraulic Center-Link

10. Press HEADER UP switch (A) to raise the header to maximum height.
11. If one end of the header does **NOT** fully raise, rephase the lift cylinders as follows:
 - a. Press and hold the HEADER UP switch until both cylinders stop moving.
 - b. Continue to hold the switch for 3–4 seconds. Cylinders are now phased.

NOTE:

It may be necessary to repeat this procedure if there is air in the system.



Figure 4.109: Ground Speed Lever

OPERATION

12. Engage the safety props on both lift cylinders as follows:
 - a. Shut down the engine, and remove the key from the ignition.
 - b. Pull lever (A) and rotate it towards the header to release and lower safety prop (B) onto the lift cylinder.
 - c. Repeat for opposite lift cylinder.

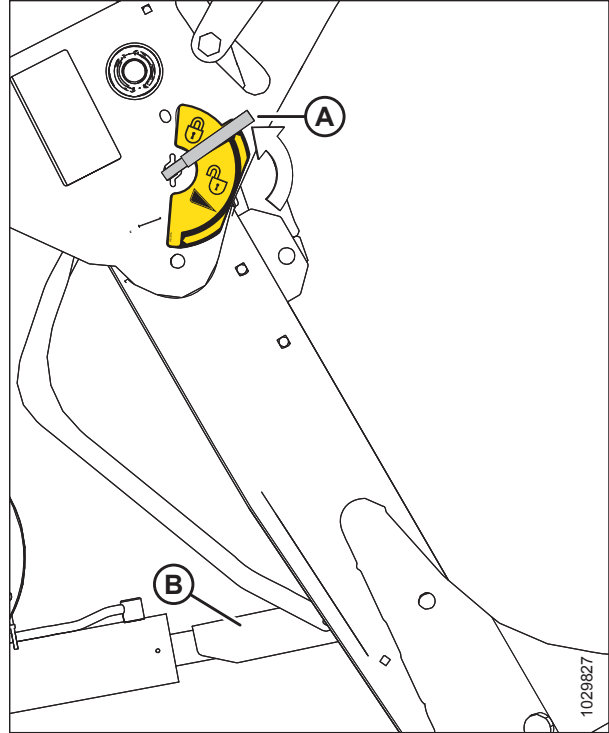

Figure 4.110: Safety Prop

13. Install pin (B) through the header leg (engaging U-bracket in lift linkage) on both sides and secure with hairpin (A).
14. Raise header stand (D) to storage position by pulling spring pin (C) and lifting stand into uppermost position. Release spring pin.

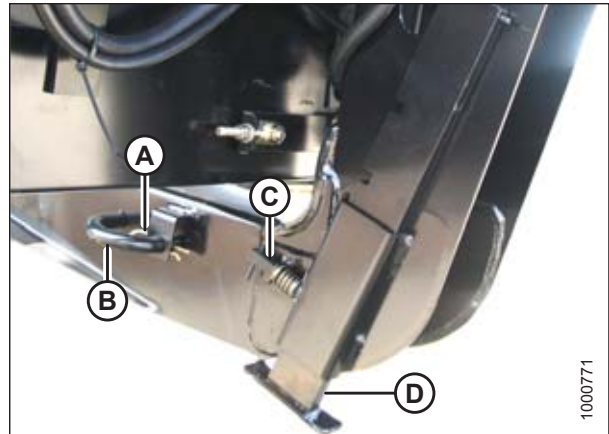

Figure 4.111: Header Leg

OPERATION

15. Remove the clevis pin from storage position (B) in linkage and insert into hole (A) to engage the float springs. Secure with hairpin.

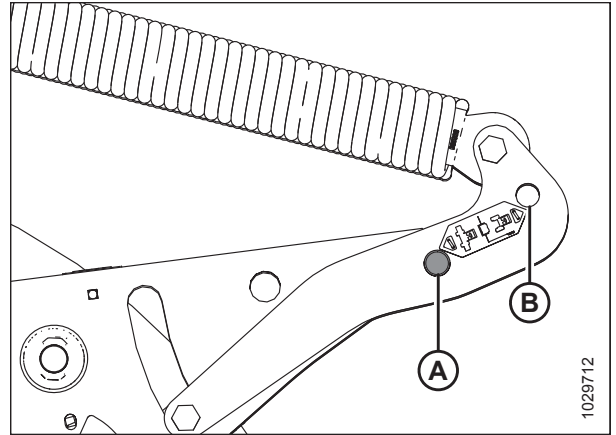

Figure 4.112: Header Float Linkage

16. Disengage the safety prop by turning lever (A) downwards until lever locks into vertical position.
17. Repeat for opposite safety prop.

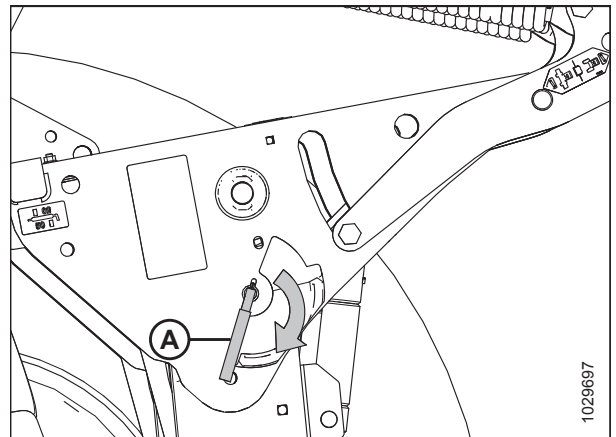

Figure 4.113: Safety Prop Lever

CAUTION

Check to be sure all bystanders have cleared the area.

18. Start the engine and press HEADER DOWN switch (A) on the GSL to fully lower the header.
19. Stop the engine and remove key from ignition.

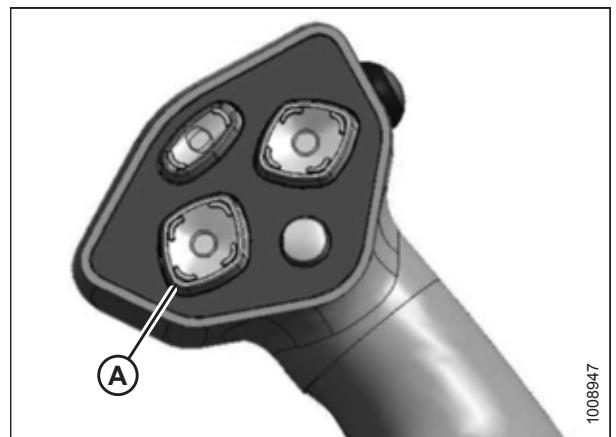

Figure 4.114: Ground Speed Lever

OPERATION

20. Connect header drive hoses (A) and electrical harness (B) to header. For instructions, refer to the header operator's manual.

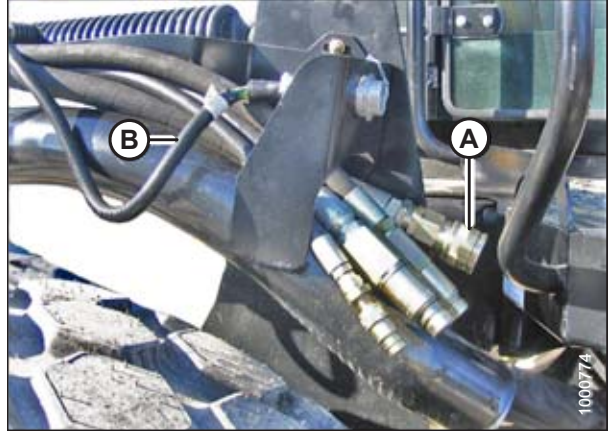

Figure 4.115: Header Drive Hoses and Harness

21. Connect reel hydraulics (A) at right cab-forward side of windrower. For instructions, refer to the draper header operator's manual.

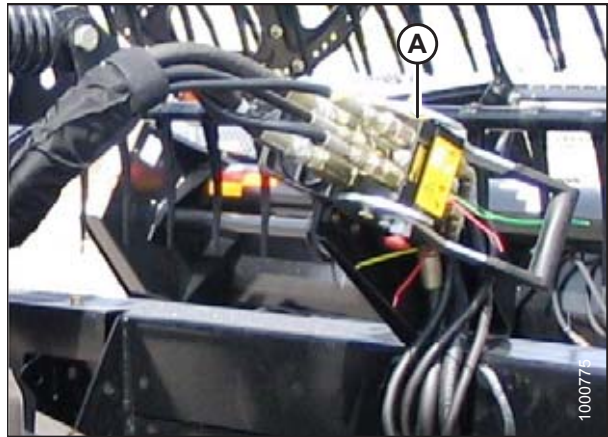

Figure 4.116: Reel Hydraulics

OPERATION

Attaching a D Series or D1 Series Draper Header – Hydraulic Center-Link without Self-Alignment

NOTE:

Draper header boots must be installed onto the windrower lift linkage before starting this procedure. For instructions, refer to [4.5.1 Attaching Header Boots, page 218](#).

WARNING

To avoid bodily injury or death from unexpected startup of the machine, always stop the engine and remove the key from the ignition before leaving the operator's seat for any reason.

1. Shut down the engine, and remove the key from the ignition.
2. Remove hairpin (A) from pins (B), and remove pins from both header legs.

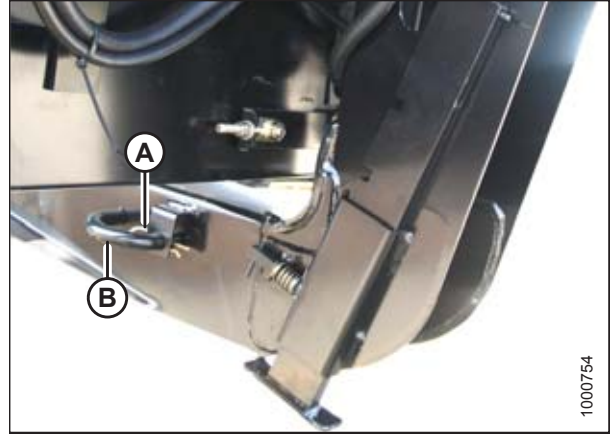

Figure 4.117: Header Leg

CAUTION

Check to be sure all bystanders have cleared the area.

IMPORTANT:

Before starting engine for the first time the windrower is operated in a season, remove protective cover from exhaust stack.

3. Start the engine and activate HEADER DOWN button (A) on the ground speed lever (GSL) to fully retract header lift cylinders.

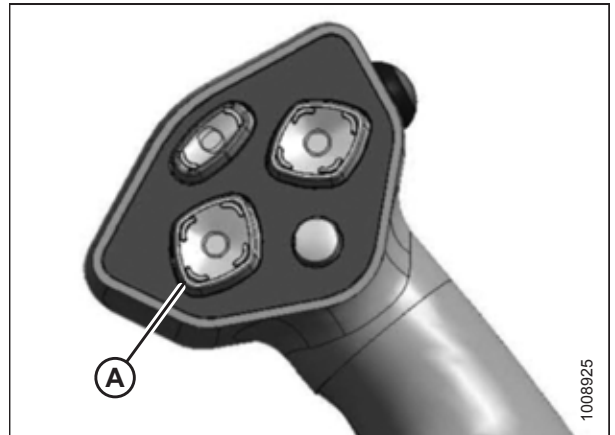

Figure 4.118: Ground Speed Lever

OPERATION

- Remove pin (A) from frame linkage and raise center-link (B) until hook is above the attachment pin on header. Replace pin (A) to hold center-link in place.

IMPORTANT:

If the center-link is too low, it may contact the header as the windrower approaches the header for hookup.

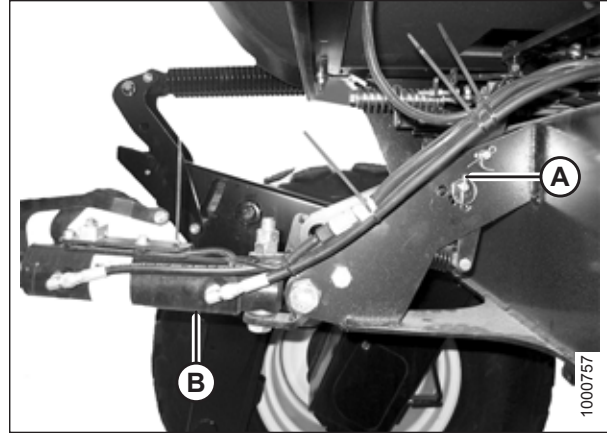

Figure 4.119: Hydraulic Center-Link without Self-Alignment Kit

- Drive the windrower slowly forward until boots (A) enter header legs (B). Continue driving slowly forward until the lift linkages contact the support plates in the header legs and the header nudges forward.
- Ensure the lift linkages are properly engaged in the header legs and are contacting the support plates.

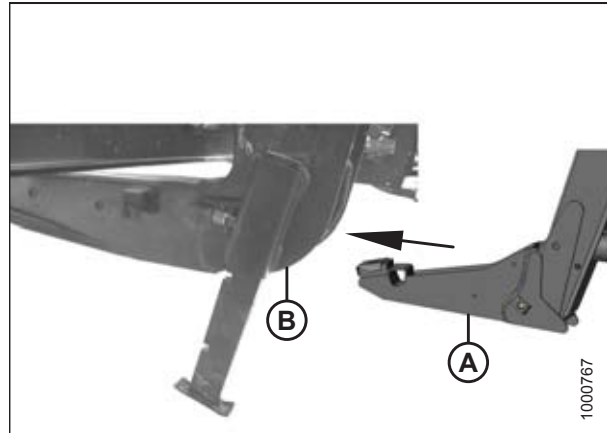

Figure 4.120: Header Leg and Boot

- Use the following GSL functions to position the center-link hook above the header attachment pin:
 - HEADER TILT UP (A) to retract the center-link
 - HEADER TILT DOWN (B) to extend the center-link
- Shut down the engine, and remove the key from the ignition.

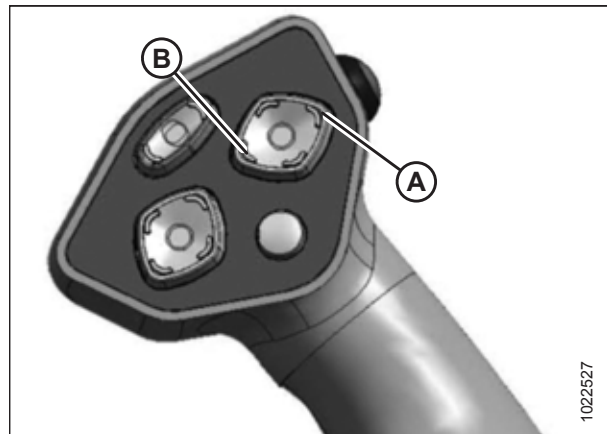

Figure 4.121: Ground Speed Lever

OPERATION

9. Push down on rod end of link cylinder (A) until hook (B) engages and locks onto header pin.

IMPORTANT:

The hook release must be down to enable the self-locking mechanism. If the release is open (up), manually push it down after hook engages header pin.

10. Check that center-link (A) is locked onto the header by pulling upward on rod end (B) of cylinder.

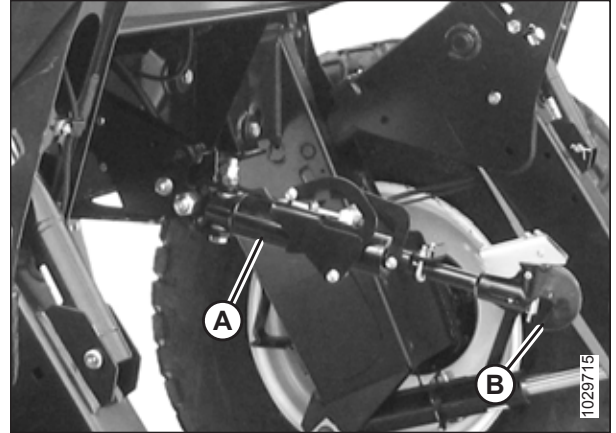

Figure 4.122: Hydraulic Center-Link

CAUTION

Check to be sure all bystanders have cleared the area.

11. Start the engine.
12. Press HEADER UP switch (A) to raise the header to maximum height.
13. If one end of the header does **NOT** fully raise, rephase the lift cylinders as follows:
 - a. Press and hold the HEADER UP switch until both cylinders stop moving.
 - b. Continue to hold the switch for 3–4 seconds. Cylinders are now phased.

NOTE:

It may be necessary to repeat this procedure if there is air in the system.



Figure 4.123: Ground Speed Lever

OPERATION

14. Engage the safety props on both lift cylinders as follows:
 - a. Shut down the engine, and remove the key from the ignition.
 - b. Pull lever (A) and rotate it towards the header to release and lower safety prop (B) onto the lift cylinder.
 - c. Repeat for opposite lift cylinder.

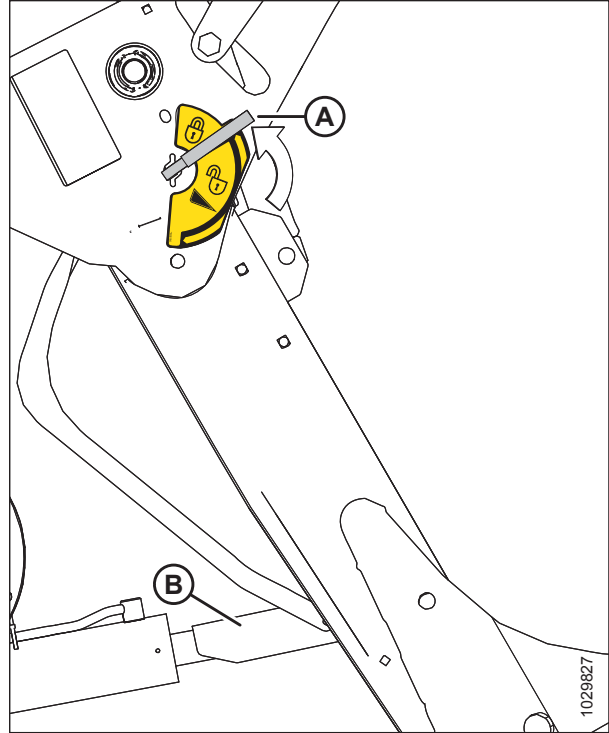

Figure 4.124: Safety Prop

15. Install pin (B) through the header leg (engaging U-bracket in lift linkage) on both sides and secure with hairpin (A).
16. Raise header stand (D) to storage position by pulling spring pin (C) and lifting stand into uppermost position. Release spring pin.

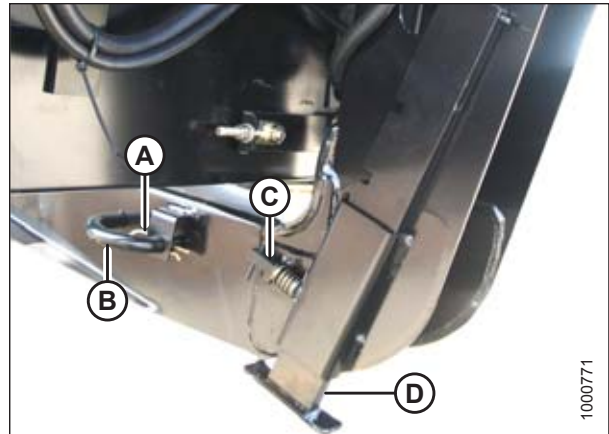

Figure 4.125: Header Leg

OPERATION

17. Remove the clevis pin from storage position (B) in linkage and insert into hole (A) to engage the float springs. Secure with hairpin.

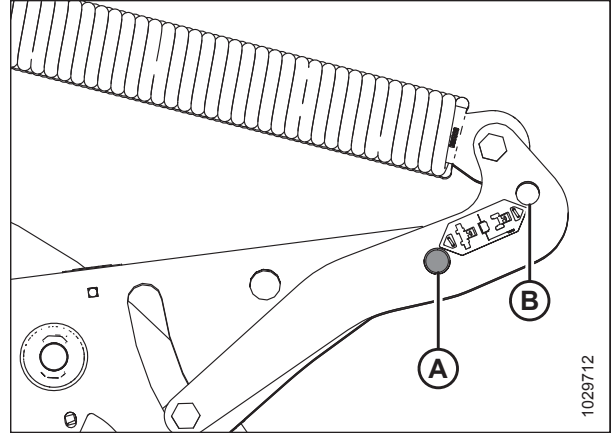

Figure 4.126: Header Float Linkage

18. Disengage the safety prop by turning lever (A) downwards until lever locks into vertical position.
19. Repeat for opposite safety prop.

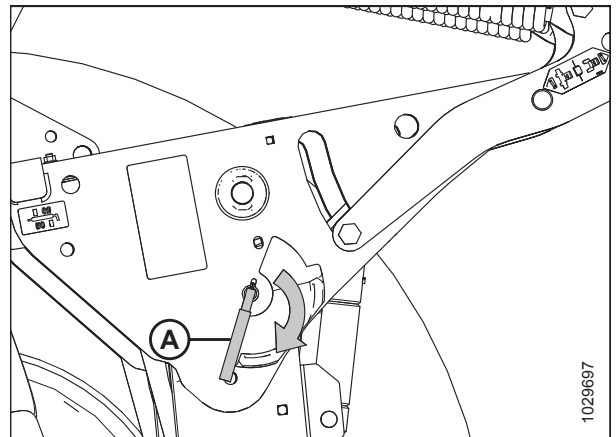

Figure 4.127: Safety Prop Lever

CAUTION

Check to be sure all bystanders have cleared the area.

20. Start the engine and press HEADER DOWN switch (A) on the GSL to fully lower the header.
21. Shut down the engine, and remove the key from the ignition.

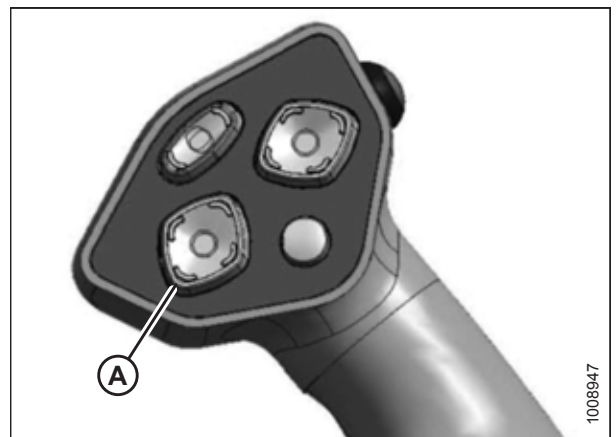

Figure 4.128: Ground Speed Lever

OPERATION

22. Connect header drive hoses (A) and electrical harness (B) to header. For instructions, refer to the header operator's manual.

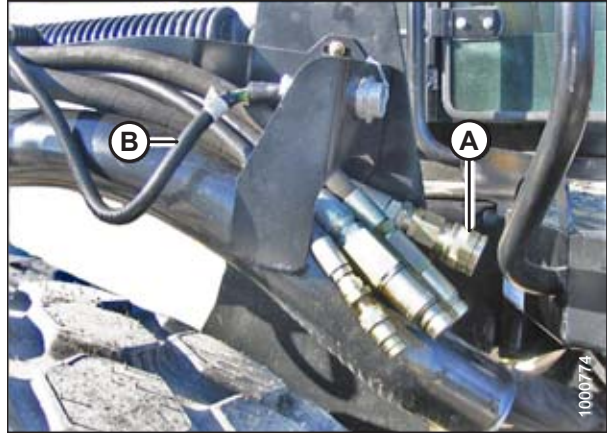

Figure 4.129: Header Drive Hoses and Harness

23. Connect reel hydraulics (A) at right cab-forward side of windrower. For instructions, refer to the draper header operator's manual.

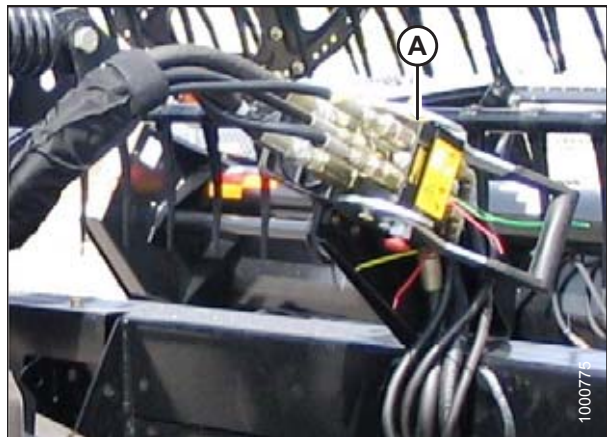

Figure 4.130: Reel Hydraulics

OPERATION

Attaching a D Series or D1 Series Draper Header – Mechanical Center-Link

NOTE:

Draper header boots must be installed onto the windrower lift linkage before starting this procedure. Refer to [4.5.1 Attaching Header Boots, page 218](#).

WARNING

To avoid bodily injury or death from unexpected startup of the machine, always stop the engine and remove the key from the ignition before leaving the operator's seat for any reason.

1. Shut down the engine, and remove the key from the ignition.
2. Remove hairpin (A) from pins (B), and remove pins from both header legs.

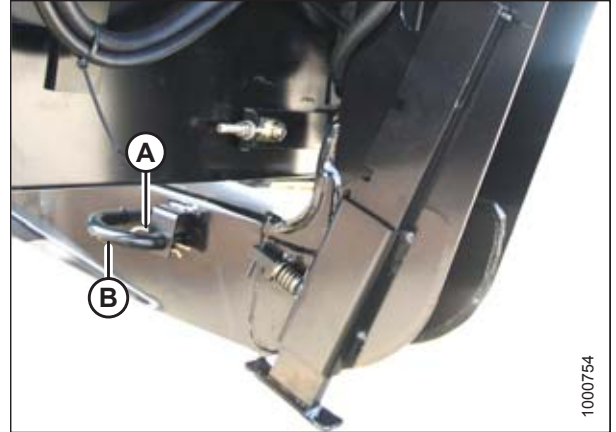

Figure 4.131: Header Leg

CAUTION

Check to be sure all bystanders have cleared the area.

IMPORTANT:

Before starting engine for the first time the windrower is operated in a season, remove protective cover from exhaust stack.

3. Start the engine and activate HEADER DOWN button (A) on the ground speed lever (GSL) to fully retract header lift cylinders.

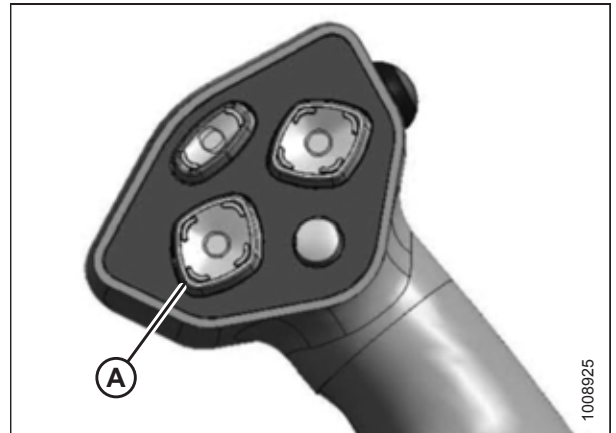

Figure 4.132: Ground Speed Lever

OPERATION

4. Drive the windrower slowly forward until boots (A) enter header legs (B). Continue driving slowly forward until the lift linkages contact the support plates in the header legs and the header nudges forward.
5. Ensure the lift linkages are properly engaged in the header legs and are contacting the support plates.

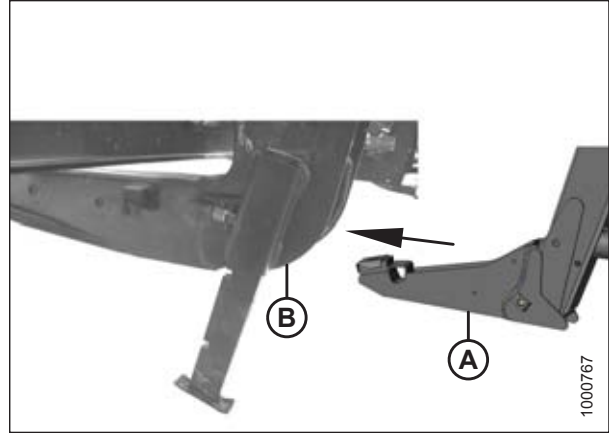

Figure 4.133: Header Leg and Boot

6. Shut down the engine, and remove the key from the ignition.
7. Loosen nut (A) and rotate barrel (B) to adjust length until the link is aligned with the header bracket.
8. Install clevis pin (C) and secure with cotter pin (D).
9. Adjust length of link to achieve proper header angle by rotating barrel (B). Tighten nut (A) against barrel (a slight tap with a hammer is sufficient).

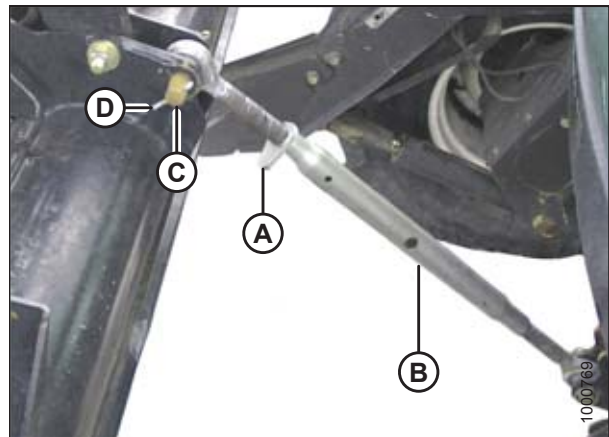

Figure 4.134: Mechanical Center-Link

CAUTION

Check to be sure all bystanders have cleared the area.

10. Start the engine.
11. Press the HEADER UP switch (A) to raise header to maximum height.
12. If one end of the header does **NOT** fully raise, rephase the lift cylinders as follows:
 - a. Press and hold the HEADER UP switch until both cylinders stop moving.
 - b. Continue to hold the switch for 3–4 seconds. Cylinders are now phased.



Figure 4.135: Ground Speed Lever

NOTE:

It may be necessary to repeat this procedure if there is air in the system.

OPERATION

13. Engage the safety props on both lift cylinders as follows:
 - a. Shut down the engine, and remove the key from the ignition.
 - b. Pull lever (A) and rotate it towards the header to release and lower safety prop (B) onto the lift cylinder.
 - c. Repeat for opposite lift cylinder.

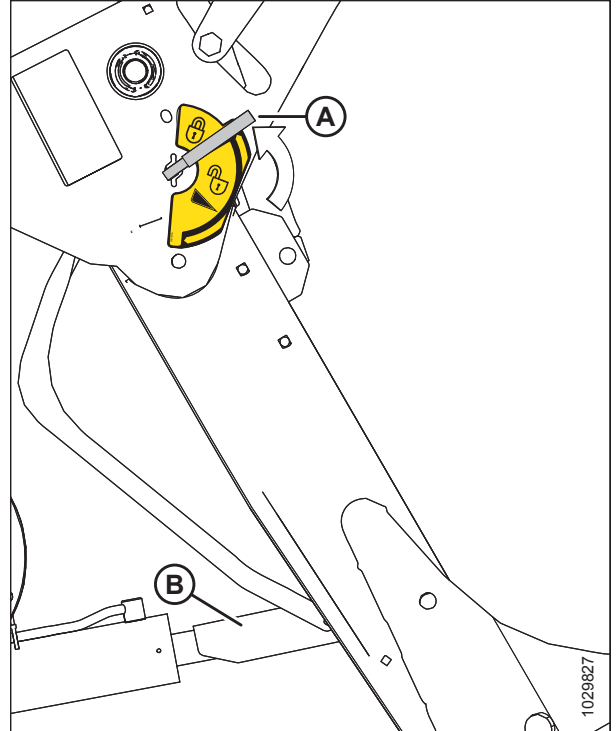

Figure 4.136: Safety Prop

14. Install pin (B) through the header leg (engaging U-bracket in lift linkage) on both sides and secure with hairpin (A).
15. Raise header stand (D) to storage position by pulling spring pin (C) and lifting stand into uppermost position. Release spring pin.

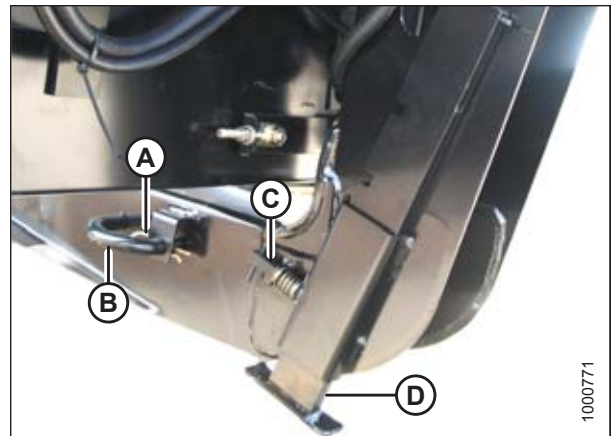

Figure 4.137: Header Leg

OPERATION

16. Remove the clevis pin from storage position (B) in linkage and insert into hole (A) to engage the float springs. Secure with hairpin.

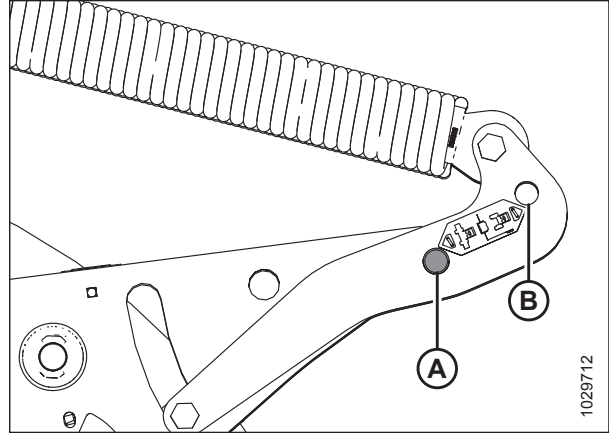

Figure 4.138: Header Float Linkage

17. Disengage the safety prop by turning lever (A) downwards until lever locks into vertical position.
18. Repeat for opposite safety prop.

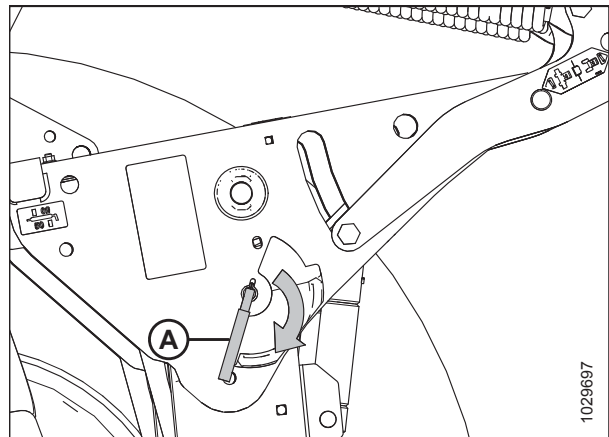

Figure 4.139: Safety Prop Lever

CAUTION

Check to be sure all bystanders have cleared the area.

19. Start the engine and press HEADER DOWN switch (A) on the GSL to fully lower the header.
20. Shut down the engine, and remove the key from the ignition.

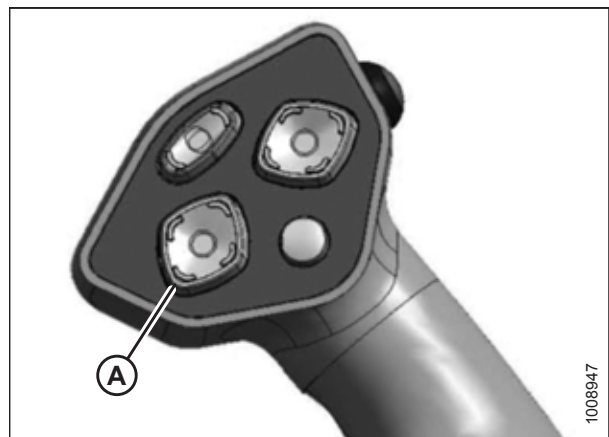

Figure 4.140: Ground Speed Lever

OPERATION

21. Connect header drive hoses (A) and electrical harness (B) to header. For instructions, refer to the header operator's manual.

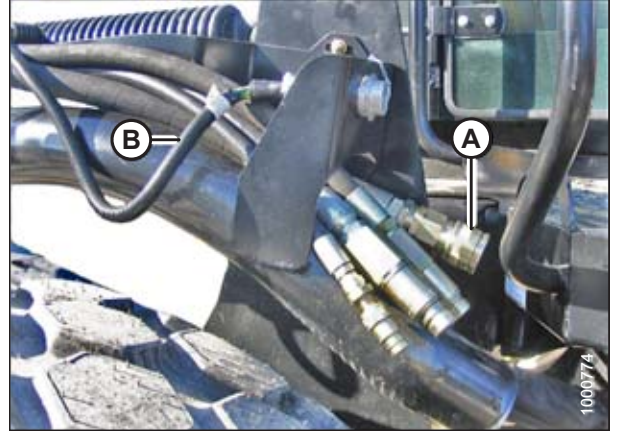

Figure 4.141: Header Drive Hoses and Harness

22. Connect reel hydraulics (A) at right cab-forward side of windrower. For instructions, refer to the draper header operator's manual.

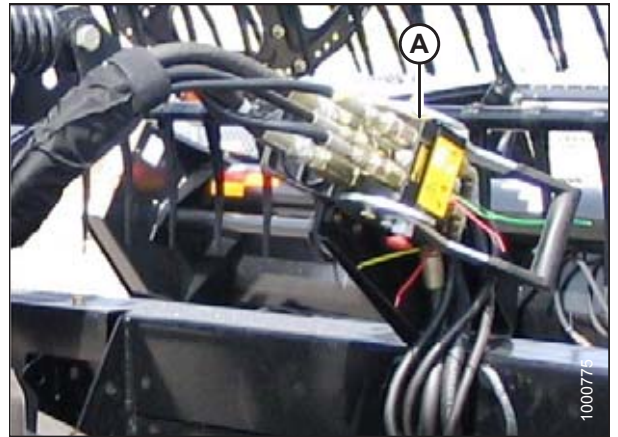

Figure 4.142: Reel Hydraulics

4.5.3 Detaching a D Series or D1 Series Draper Header

Refer to the procedure that is appropriate for the center-link installed on the windrower:

- *Detaching a D Series or D1 Series Draper Header – Hydraulic Center-Link, page 236*
- *Detaching a D Series Header – Mechanical Center-Link, page 240*

Detaching a D Series or D1 Series Draper Header – Hydraulic Center-Link

WARNING

To avoid bodily injury or death from unexpected startup of the machine, always stop the engine and remove the key from the ignition before leaving the operator's seat for any reason.

1. Start engine and press HEADER UP switch (A) to raise header to maximum height.
2. Rephase cylinders if one end of the header does not raise fully. If rephasing is required, proceed as follows:
 - a. Press and hold the HEADER UP switch (A) until both cylinders stop moving.
 - b. Continue to hold the switch for 3–4 seconds. Cylinders are now phased.
3. Shut down the engine, and remove the key from the ignition.



Figure 4.143: Ground Speed Lever (GSL)

4. Pull lever (A) and rotate it toward the header to lower safety prop (B) onto the cylinder. Repeat for the opposite cylinder.

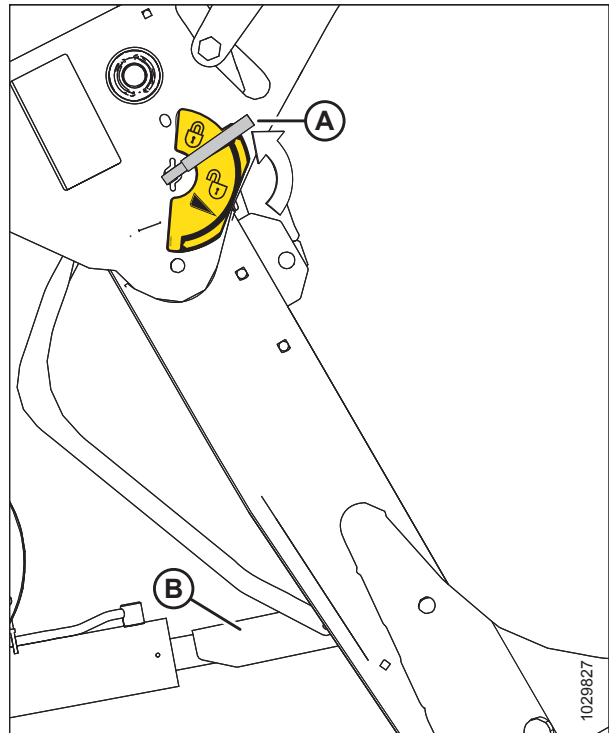

Figure 4.144: Safety Prop

OPERATION

5. Remove pin (B) by removing hairpin (A) from header leg on both sides.
6. Lower header stand (D) by pulling spring loaded pin (C). Release spring pin to lock stand.

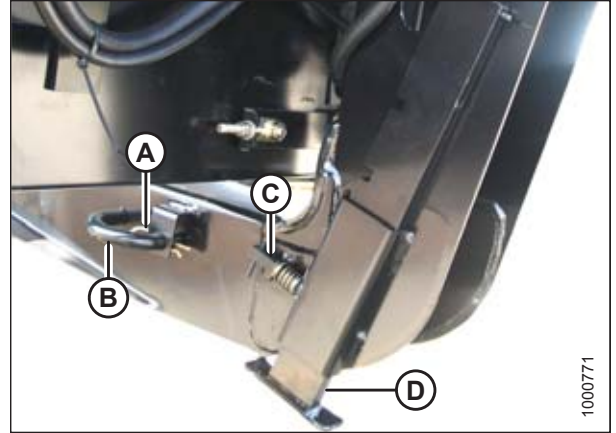

Figure 4.145: Header Stand

7. Remove the clevis pin from location (A) to disengage the float springs and insert in it storage hole (B). Secure with lynch pin.

CAUTION

To prevent damage to the lift system when lowering header lift linkages without a header or weight box attached to the windrower, ensure the float engagement pin is installed in storage position (B) and NOT in engaged position (A).

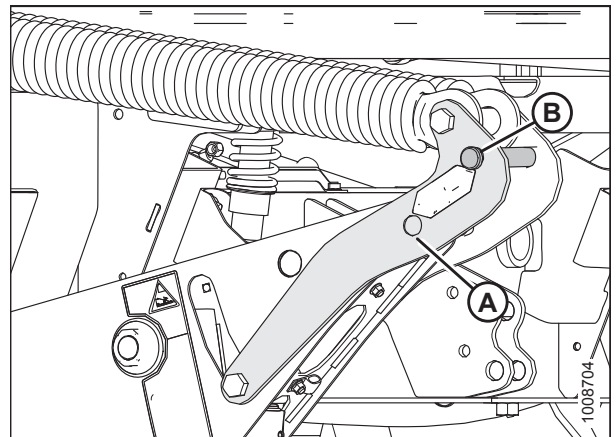

Figure 4.146: Header Float Linkage

8. Turn lever (A) away from header to raise safety prop until lever locks into vertical position. Repeat for opposite cylinder.
9. Start the engine, choose a level area, and lower the header to the ground.
10. Shut down the engine, and remove the key from the ignition.

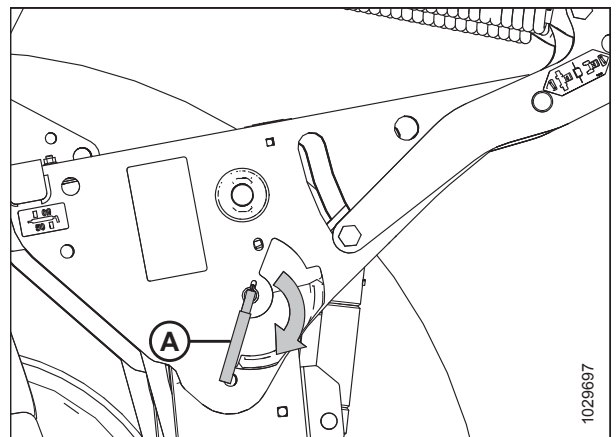

Figure 4.147: Safety Prop

OPERATION

11. Disconnect header drive hydraulics (A) and electrical harness (B) from the header and store them in support on windrower left cab-forward side. Refer to the draper header operator's manual for further information.

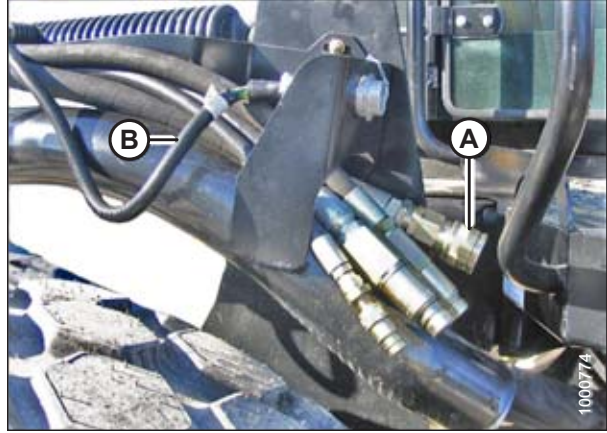

Figure 4.148: Header Drive Hydraulics

12. Disconnect reel hydraulics (A) from header and store on bracket at windrower left cab-forward side. Refer to the draper header operator's manual for further information.

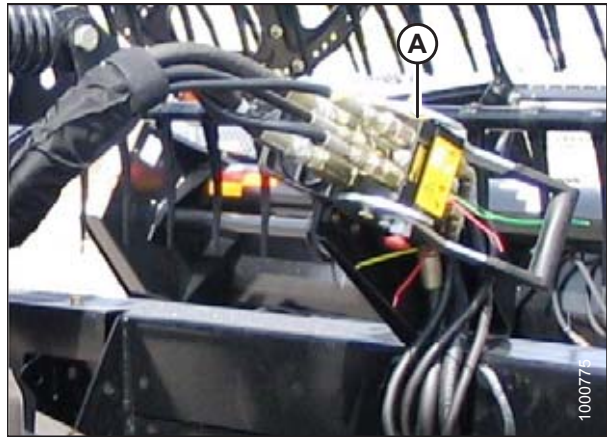

Figure 4.149: Reel Hydraulics

CAUTION

Check to be sure all bystanders have cleared the area.

13. Start the engine, and activate HEADER TILT UP (A) and HEADER TILT DOWN (B) cylinder switches on the ground speed lever (GSL) to release load on the center-link cylinder.

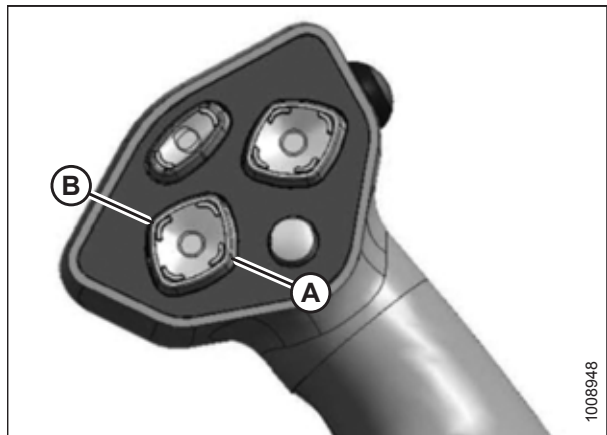

Figure 4.150: Ground Speed Lever

OPERATION

14. Disconnect center-link by lifting release (B) and hook (A) off header.

NOTE:

If optional center-link self-alignment kit is installed, lift release (B) and then operate the link lift cylinder with REEL UP switch on the GSL to disengage the center-link from the header.

NOTE:

If a hay conditioner is installed, watch clearances on both sides.

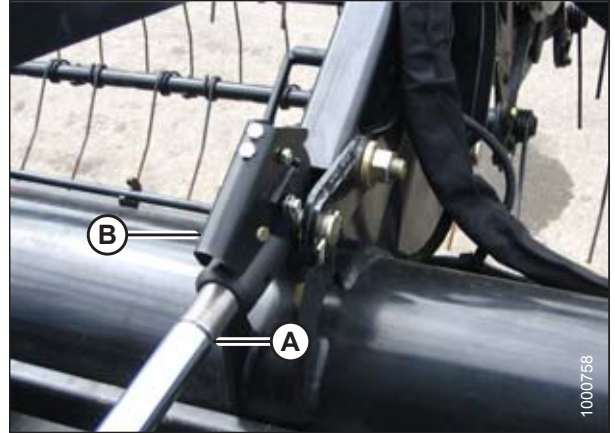

Figure 4.151: Hydraulic Center-Link

15. Reinstall pin (A) into header leg and secure with a hairpin (B).

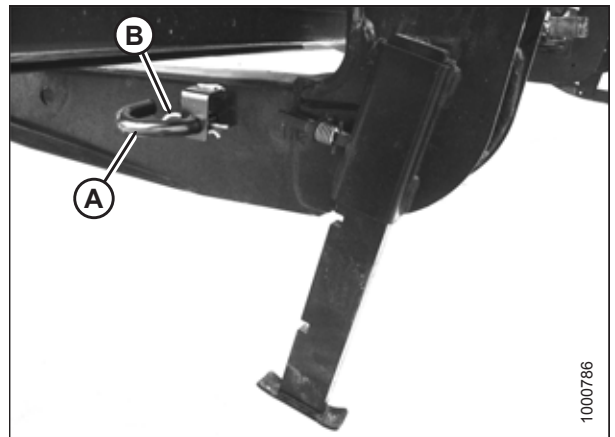

Figure 4.152: Header Stand

OPERATION

Detaching a D Series Header – Mechanical Center-Link

To detach a D Series header from an M Series windrower equipped with mechanical center-link, follow these steps:

WARNING

To avoid bodily injury or death from unexpected startup of the machine, always stop the engine and remove the key from the ignition before leaving the operator's seat for any reason.

1. Start engine and press HEADER UP (A) switch to raise header to maximum height.
2. If one end of the header does **NOT** raise completely, rephase the cylinders as follows:
 - a. Press and hold the HEADER UP (A) switch on the ground speed lever (GSL) until both cylinders stop moving.
 - b. Continue to hold the switch for 3–4 seconds. Cylinders are phased.
3. Stop engine and remove key.
4. Pull lever (A) and rotate it toward the header to lower safety prop (B) onto the cylinder. Repeat for the opposite cylinder.



Figure 4.153: Ground Speed Lever

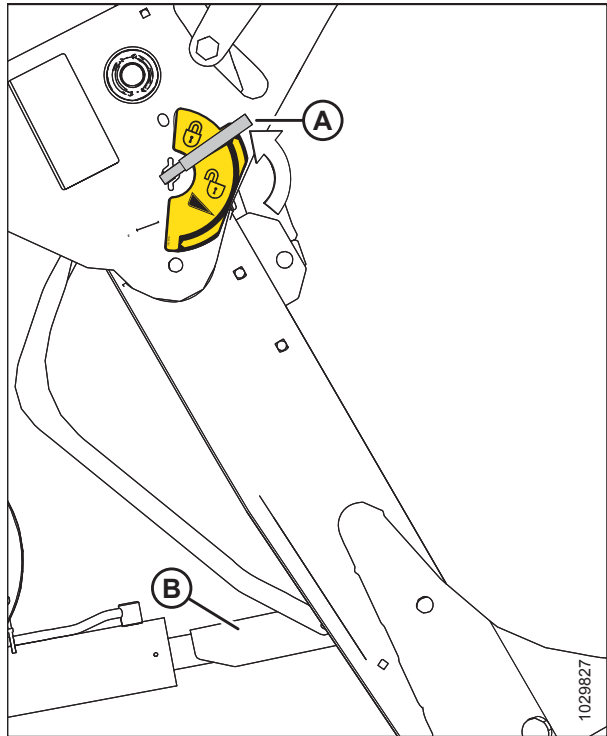

Figure 4.154: Safety Prop

OPERATION

5. Remove the clevis pin (B) by removing hairpin (A) from header leg on both sides.
6. Lower header stand (D) by pulling spring loaded pin (C). Release pin to lock stand.

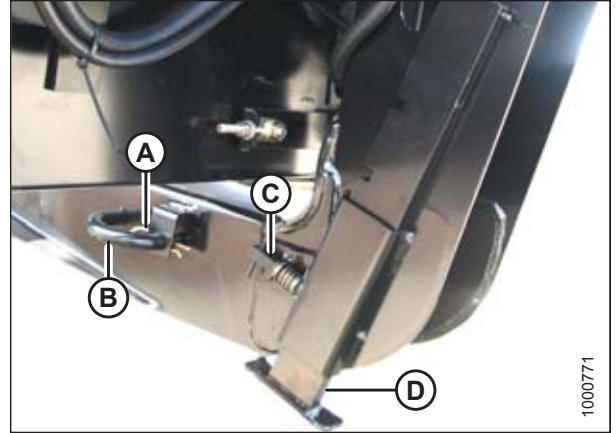

Figure 4.155: Header Stand

7. Remove the clevis pin from location (A) to disengage float springs and insert in storage hole (B). Secure with lynch pin.

CAUTION

To prevent damage to the lift system when lowering header lift linkages without a header or weight box attached to the windrower, ensure the float engagement pin is installed in storage position (B) and NOT in engaged position (A).

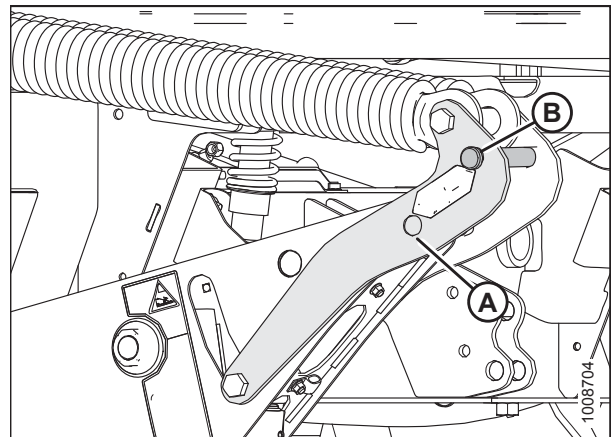

Figure 4.156: Header Float Linkage

8. Turn lever (A) away from header to raise safety prop until lever locks into vertical position. Repeat for opposite cylinder.
9. Start the engine, choose a level area, and lower the header to the ground.
10. Shut down the engine, and remove the key from the ignition.

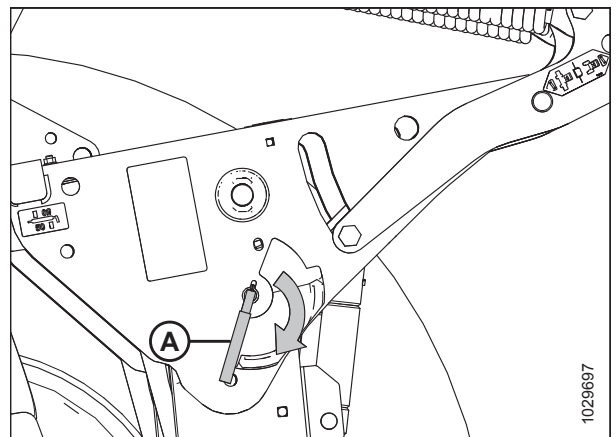

Figure 4.157: Safety Prop

OPERATION

11. Disconnect header drive hydraulics (A) and electrical harness (B) from header and store in support on windrower left cab-forward side. Refer to the draper header operator's manual for further information.

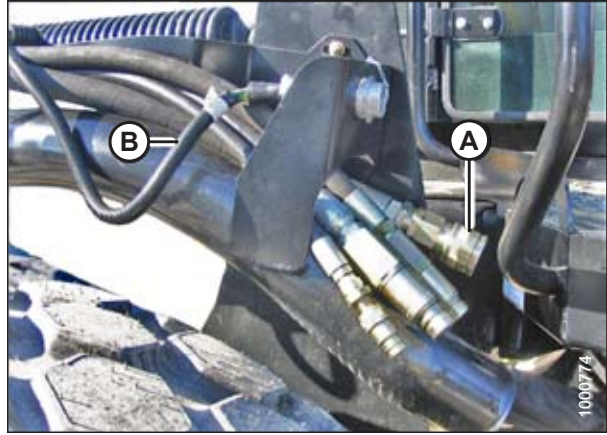

Figure 4.158: Header Drive Hydraulics

12. Disconnect reel hydraulics (A) from header and store on bracket at windrower left cab-forward side. Refer to the draper header operator's manual for further information.

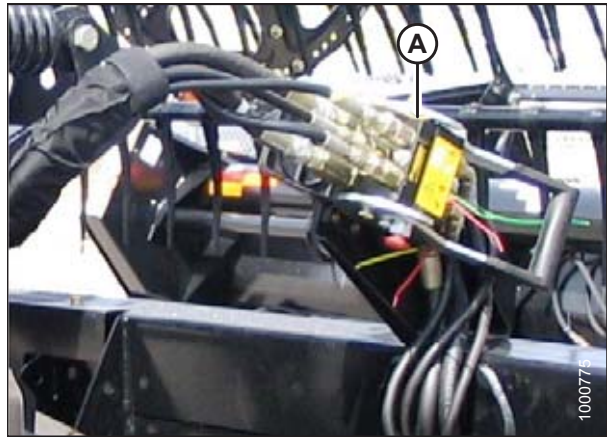

Figure 4.159: Reel Hydraulics

13. Loosen nut (A) and rotate barrel (B) to relieve load on link.
14. Remove cotter pin on clevis pin (D) and remove the pin (C) to disconnect from windrower. Reinstall clevis pin (C) in header.
15. Tighten nut (A) against barrel. A slight tap with a hammer is sufficient.

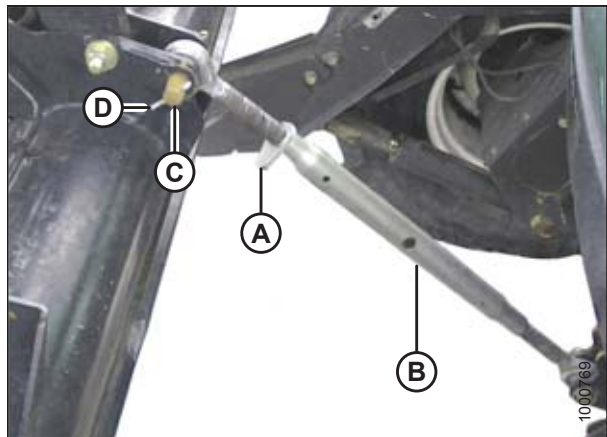

Figure 4.160: Mechanical Center-Link

OPERATION

16. Reinstall pin (A) into header leg and secure with a hairpin (B).

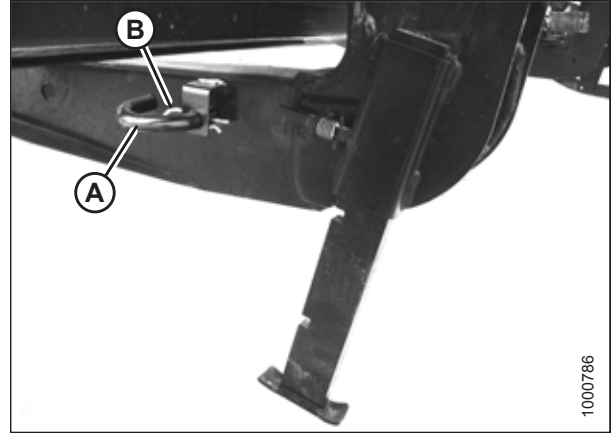

Figure 4.161: Header Leg

4.5.4 Attaching an A Series Header

Refer to the following instructions based on the type of center-link installed on your windrower:

- *Attaching an A Series Header – Hydraulic Center-Link with Optional Self-Alignment, page 243*
- *Attaching an A Series Header – Hydraulic Center-Link without Self-Alignment, page 249*
- *Attaching an A Series Header – Mechanical Center-Link, page 254*

Attaching an A Series Header – Hydraulic Center-Link with Optional Self-Alignment



WARNING

To avoid bodily injury or death from unexpected startup of the machine, always stop the engine and remove the key from the ignition before leaving the operator's seat for any reason.

1. Shut down the engine, and remove the key from the ignition.
2. Remove hairpin (A) from clevis pin (B) and remove clevis pin from header boots (C) on both sides of the header.

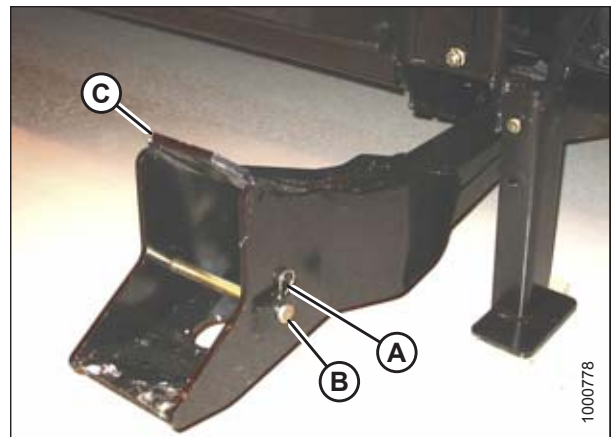

Figure 4.162: Header Boot

OPERATION

IMPORTANT:

To prevent damage to the lift system when lowering header lift linkages without a header or weight box attached to the windrower, ensure the float engagement pin is installed in storage position (B) and **NOT** in engaged position (A).

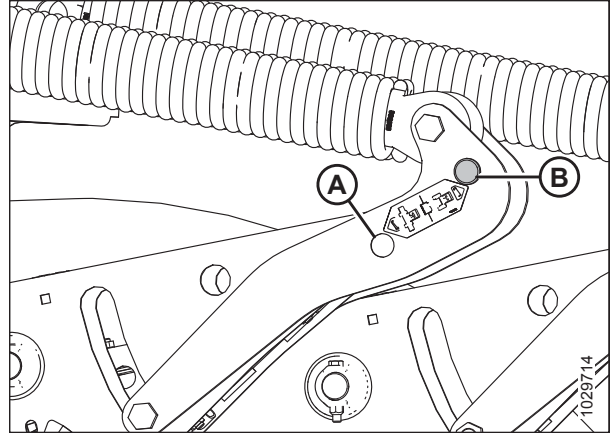

Figure 4.163: Header Float Linkage

CAUTION

Check to be sure all bystanders have cleared the area.

IMPORTANT:

Before starting engine for the first time the windrower is operated in a season, remove protective cover from exhaust stack.

3. Start the engine and activate HEADER DOWN button (A) on the ground speed lever (GSL) to fully retract header lift cylinders.
4. Press REEL UP switch (A) on the GSL to raise the center-link until the hook is above the attachment pin on the header.

IMPORTANT:

If the center-link is too low, it may contact the header as the windrower approaches the header for hookup.

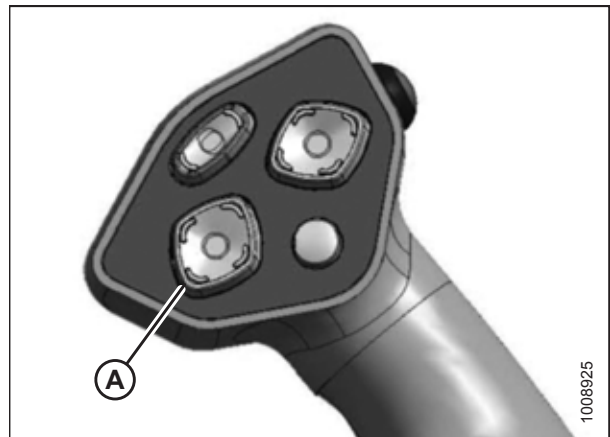

Figure 4.164: Ground Speed Lever

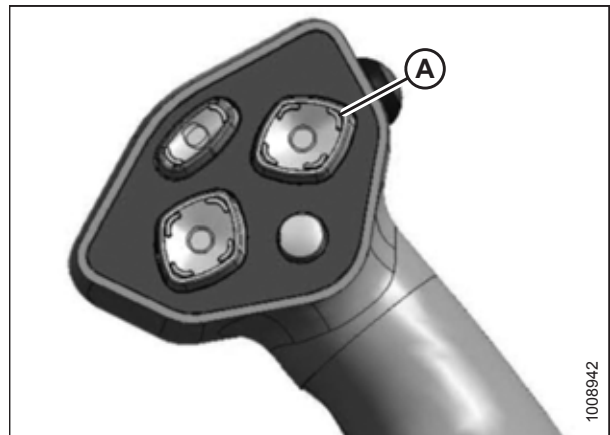

Figure 4.165: Ground Speed Lever

OPERATION

5. Drive the windrower slowly forward until windrower feet (A) enter header supports (B). Continue driving slowly forward until the feet engage the supports and the header nudges forward.

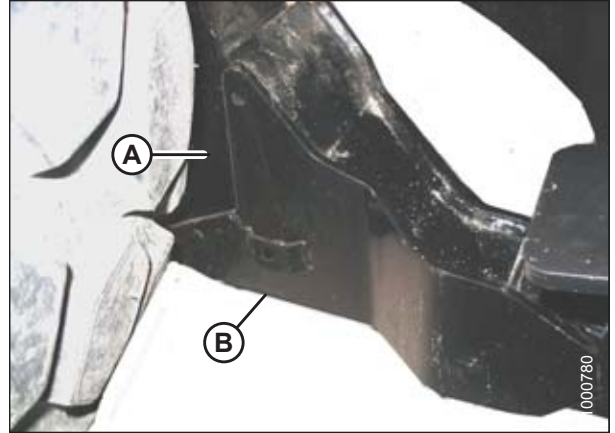

Figure 4.166: Header Support

6. Use the following GSL functions to position the center-link hook above the header attachment pin:
 - REEL UP (A) to raise the center-link
 - REEL DOWN (B) to lower the center-link
 - HEADER TILT UP (C) to retract the center-link
 - HEADER TILT DOWN (D) to extend the center-link

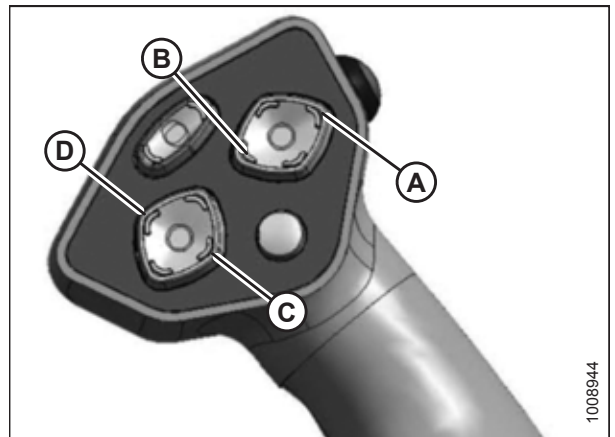

Figure 4.167: Ground Speed Lever

IMPORTANT:

Hook release must be down to enable self-locking mechanism. If the release is open (up), manually push it down after hook engages header pin.

7. Adjust center-link cylinder (A) position with the REEL UP and REEL DOWN switches on the GSL until the hook is positioned above the header attachment pin.

IMPORTANT:

Hook release (B) must be down to enable the self-locking mechanism. If the release is open (up), manually push it down after hook engages header pin.

8. Lower center-link (A) onto the header with the REEL DOWN switch until the center-link locks into position and hook release (B) is down.
9. Check that center-link is locked onto header by pressing the REEL UP switch on the GSL.

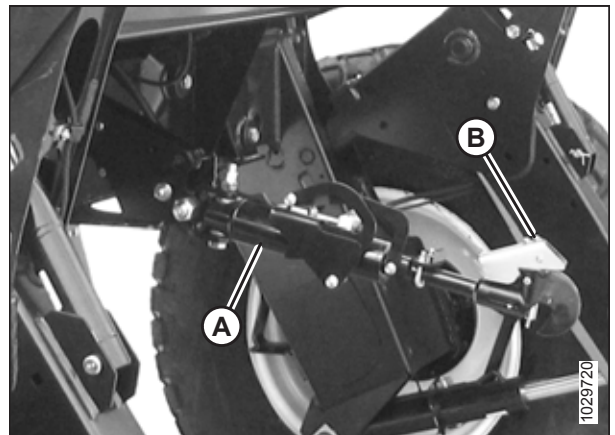

Figure 4.168: Hydraulic Center-Link

CAUTION

Check to be sure all bystanders have cleared the area.

OPERATION

10. Press HEADER UP switch (A) to raise the header to maximum height.
11. If one end of the header does **NOT** fully raise, rephase the lift cylinders as follows:
 - a. Press and hold the HEADER UP switch until both cylinders stop moving.
 - b. Continue to hold the switch for 3–4 seconds. Cylinders are now phased.

NOTE:

It may be necessary to repeat this procedure if there is air in the system.



Figure 4.169: Ground Speed Lever

12. Engage the safety props on both lift cylinders as follows:
 - a. Shut down the engine, and remove the key from the ignition.
 - b. Pull lever (A) and rotate it towards the header to release and lower safety prop (B) onto the lift cylinder.
 - c. Repeat for opposite lift cylinder.

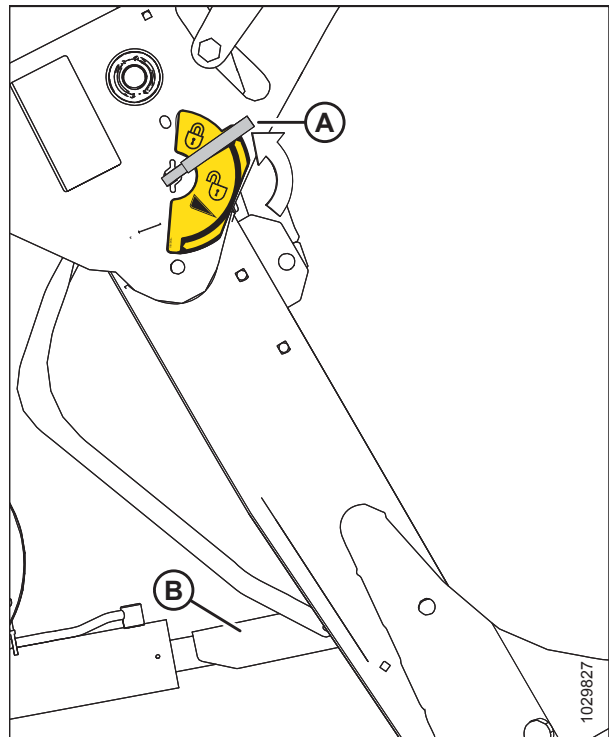

Figure 4.170: Safety Prop

OPERATION

13. Install clevis pin (A) through support and foot, and secure with hairpin. Repeat for opposite support.

IMPORTANT:

Ensure clevis pin (A) is fully inserted and hairpin is installed behind bracket.



Figure 4.171: Header Support

14. Remove lynch pin from clevis pin (A) in stand (B).
15. Hold stand (B) and remove pin (A).
16. Move stand (B) to storage position by inverting and relocating onto bracket as shown. Reinsert clevis pin (A) and secure with lynch pin.

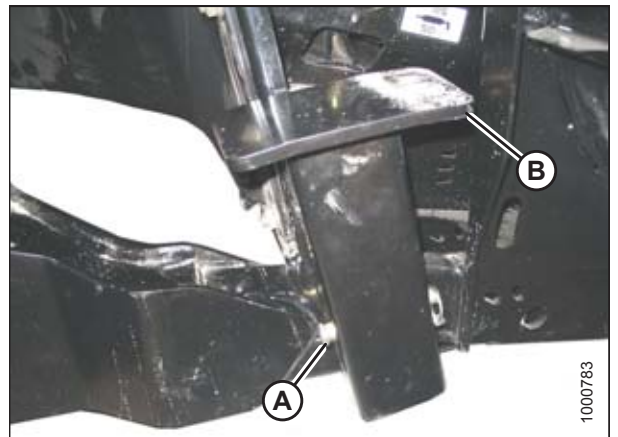

Figure 4.172: Header Stand

17. Remove the clevis pin from storage position (B) in linkage and insert into hole (A) to engage the float springs. Secure with hairpin.

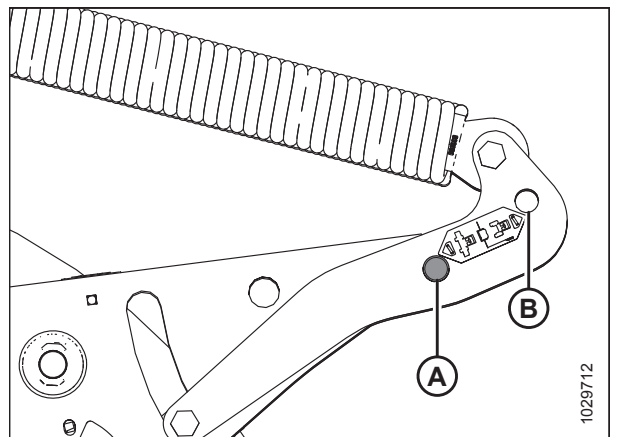

Figure 4.173: Header Float Linkage

OPERATION

18. Disengage the safety prop by turning lever (A) downwards until lever locks into vertical position.
19. Repeat for opposite safety prop.

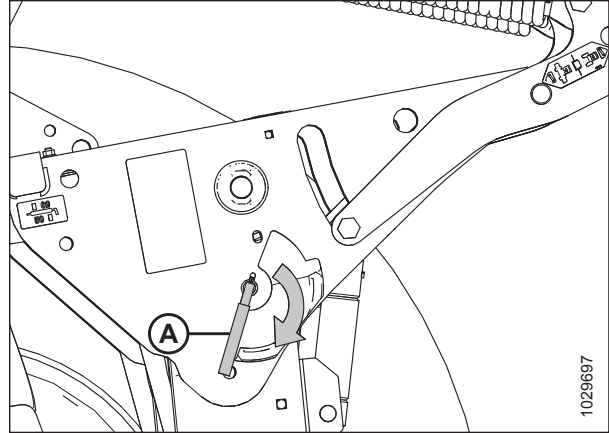

Figure 4.174: Safety Prop Lever

CAUTION

Check to be sure all bystanders have cleared the area.

20. Start the engine and press HEADER DOWN switch (A) on the GSL to fully lower the header.
21. Stop the engine and remove key from ignition.

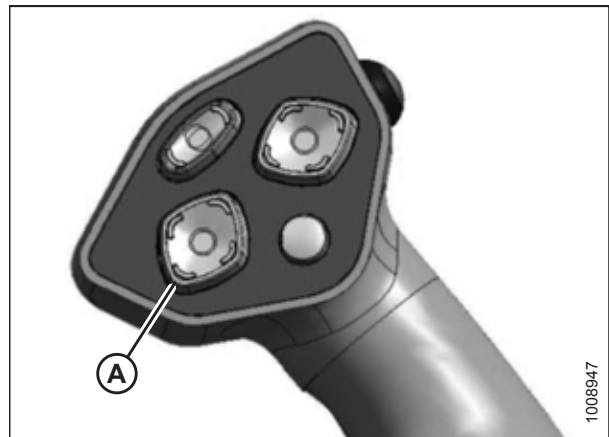

Figure 4.175: Ground Speed Lever

22. Connect header drive hoses (A) and electrical harness (B) to header. For instructions, refer to the header operator's manual.

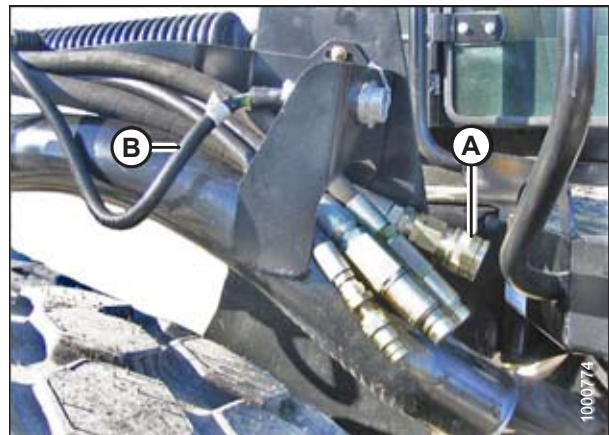

Figure 4.176: Header Drive Hoses and Harness

Attaching an A Series Header – Hydraulic Center-Link without Self-Alignment

WARNING

To avoid bodily injury or death from unexpected startup of the machine, always stop the engine and remove the key from the ignition before leaving the operator's seat for any reason.

1. Shut down the engine, and remove the key from the ignition.
2. Remove hairpin (A) from clevis pin (B) and remove clevis pin from header boots (C) on both sides of the header.

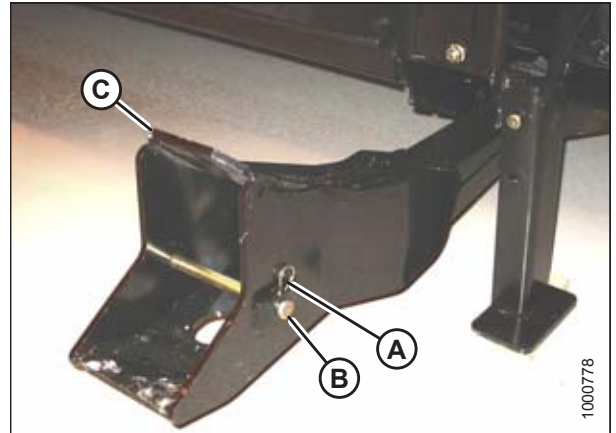

Figure 4.177: Header Boot

IMPORTANT:

To prevent damage to the lift system when lowering header lift linkages without a header or weight box attached to the windrower, ensure the float engagement pin is installed in storage position (B) and **NOT** in engaged position (A).

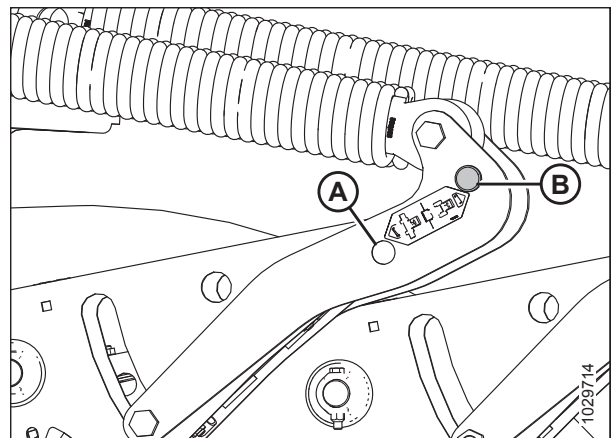

Figure 4.178: Header Float Linkage

CAUTION

Check to be sure all bystanders have cleared the area.

IMPORTANT:

Before starting engine for the first time the windrower is operated in a season, remove protective cover from exhaust stack.

3. Start the engine and activate HEADER DOWN button (A) on the ground speed lever (GSL) to fully retract header lift cylinders.

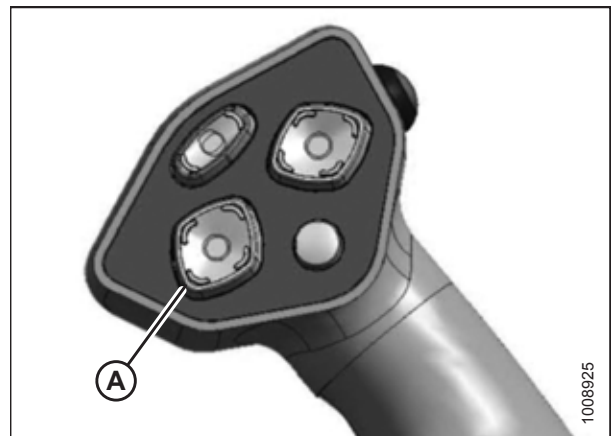

Figure 4.179: Ground Speed Lever

OPERATION

- Remove pin (A) from frame linkage and raise center-link (B) until hook is above the attachment pin on header. Replace pin (A) to hold center-link in place.

IMPORTANT:

If the center-link is too low, it may contact the header as the windrower approaches the header for hookup.

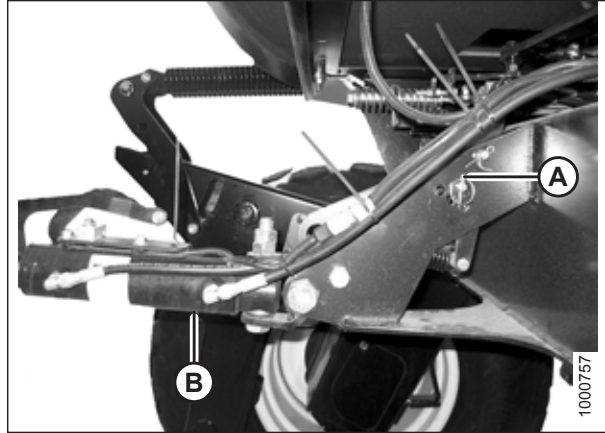

Figure 4.180: Hydraulic Center-Link without Self-Alignment Kit

- Drive the windrower slowly forward until windrower feet (A) enter header supports (B). Continue driving slowly forward until the feet engage the supports and the header nudges forward.

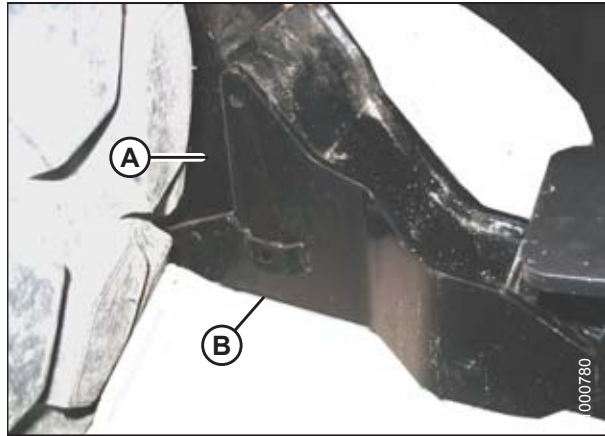

Figure 4.181: Header Support

- Use the following ground speed lever functions to position the center-link hook above the header attachment pin:
 - HEADER TILT UP (A) to retract center-link
 - HEADER TILT DOWN (B) to extend center-link
- Stop engine and remove key from ignition.

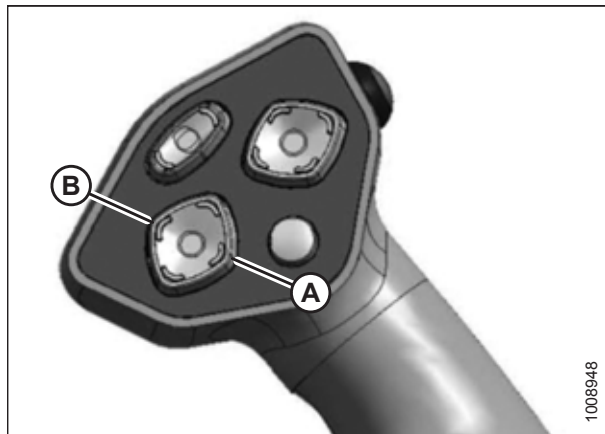

Figure 4.182: Ground Speed Lever

OPERATION

8. Push down on rod end of link cylinder (A) until hook (B) engages and locks onto header pin.

IMPORTANT:

The hook release must be down to enable the self-locking mechanism. If the release is open (up), manually push it down after hook engages header pin.

9. Check that center-link (A) is locked onto the header by pulling upward on rod end (B) of cylinder.

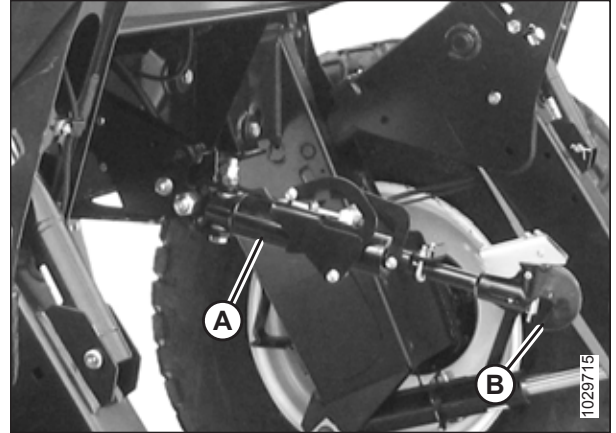

Figure 4.183: Hydraulic Center-Link

CAUTION

Check to be sure all bystanders have cleared the area.

10. Start the engine.
11. Press HEADER UP switch (A) to raise header to maximum height.
12. If one end of the header does **NOT** fully raise, rephase the lift cylinders as follows:
 - a. Press and hold the HEADER UP switch until both cylinders stop moving.
 - b. Continue to hold the switch for 3–4 seconds. Cylinders are now phased.

NOTE:

It may be necessary to repeat this procedure if there is air in the system.



Figure 4.184: Ground Speed Lever

OPERATION

13. Engage the safety props on both lift cylinders as follows:
 - a. Shut down the engine, and remove the key from the ignition.
 - b. Pull lever (A) and rotate it towards the header to release and lower safety prop (B) onto the lift cylinder.
 - c. Repeat for opposite lift cylinder.

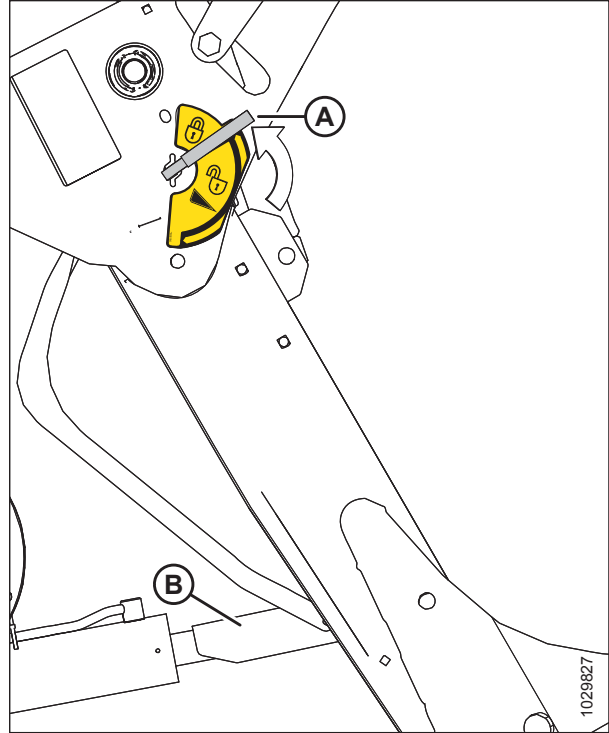

Figure 4.185: Safety Prop

14. Install clevis pin (A) through support and foot, and secure with hairpin. Repeat for opposite support.

IMPORTANT:

Ensure clevis pin (A) is fully inserted and hairpin is installed behind bracket.

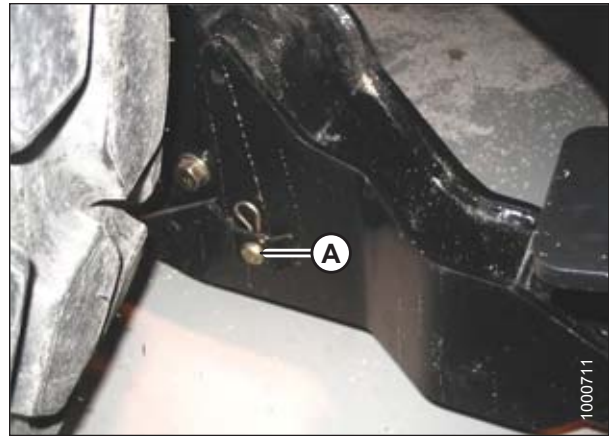

Figure 4.186: Header Support

OPERATION

15. Remove lynch pin from clevis pin (A) in stand (B).
16. Hold stand (B) and remove pin (A).
17. Move stand (B) to storage position by inverting and relocating onto bracket as shown. Reinsert clevis pin (A) and secure with lynch pin.

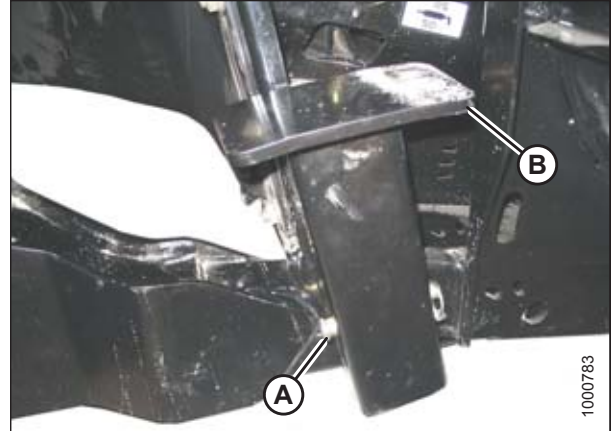

Figure 4.187: Header Stand

18. Remove the clevis pin from storage position (B) in linkage and insert into hole (A) to engage the float springs. Secure with hairpin.

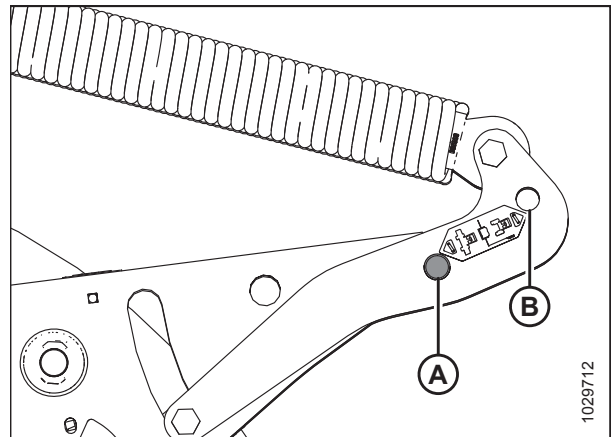

Figure 4.188: Header Float Linkage

19. Disengage the safety prop by turning lever (A) downwards until lever locks into vertical position.
20. Repeat for opposite safety prop.

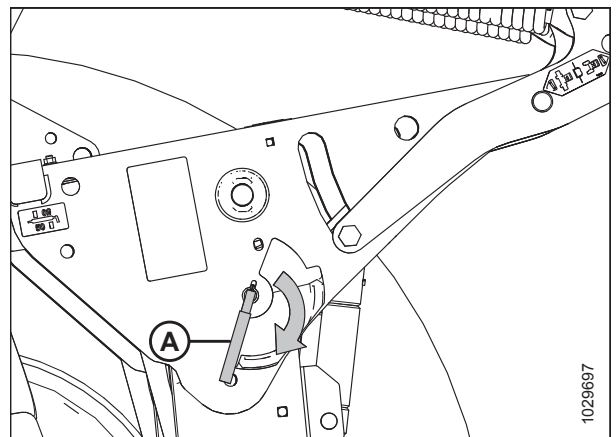

Figure 4.189: Safety Prop Lever

OPERATION

CAUTION

Check to be sure all bystanders have cleared the area.

21. Start the engine and press HEADER DOWN switch (A) on the GSL to fully lower the header.
22. Stop the engine and remove key from ignition.

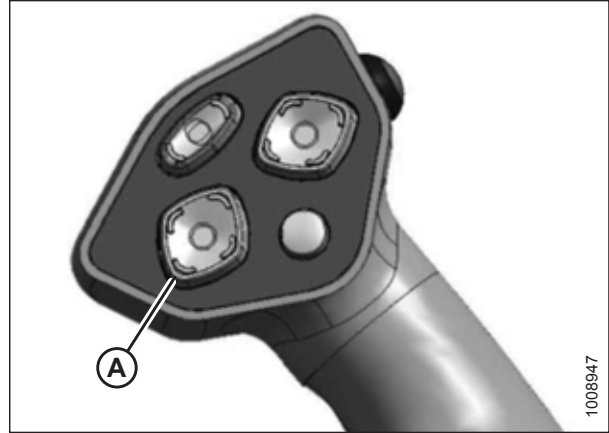

Figure 4.190: Ground Speed Lever

23. Connect header drive hoses (A) and electrical harness (B) to header. For instructions, refer to the header operator's manual.

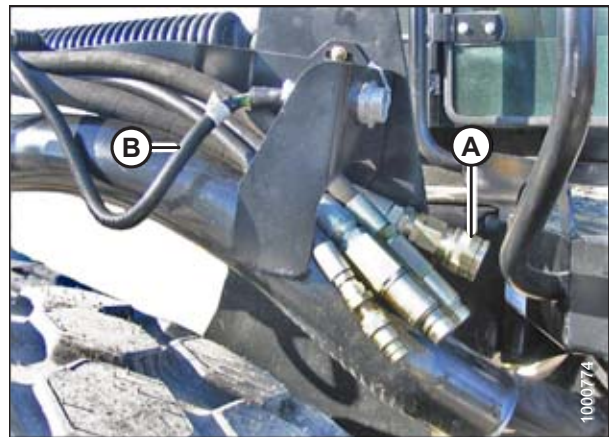

Figure 4.191: Header Drive Hoses and Harness

Attaching an A Series Header – Mechanical Center-Link

WARNING

To avoid bodily injury or death from unexpected startup of the machine, always stop the engine and remove the key from the ignition before leaving the operator's seat for any reason.

1. Shut down the engine, and remove the key from the ignition.
2. Remove hairpin (A) from clevis pin (B) and remove clevis pin from header boots (C) on both sides of the header.

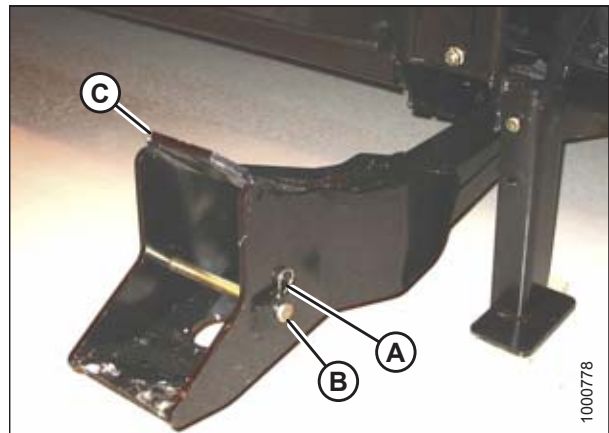

Figure 4.192: Header Boot

OPERATION

IMPORTANT:

To prevent damage to the lift system when lowering header lift linkages without a header or weight box attached to the windrower, ensure the float engagement pin is installed in storage position (B) and **NOT** in engaged position (A).

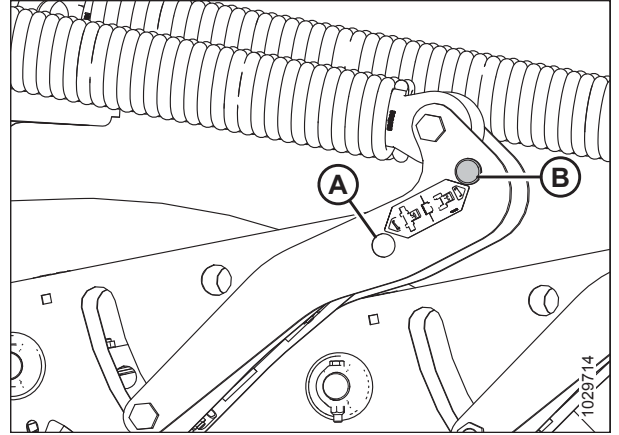

Figure 4.193: Header Float Linkage

CAUTION

Check to be sure all bystanders have cleared the area.

IMPORTANT:

Before starting engine for the first time the windrower is operated in a season, remove protective cover from exhaust stack.

3. Start the engine and activate HEADER DOWN button (A) on the ground speed lever (GSL) to fully retract header lift cylinders.
4. Drive the windrower slowly forward until boots (A) enter header legs (B). Continue driving slowly forward until the lift linkages contact the support plates in the header legs and the header nudges forward.
5. Ensure the lift linkages are properly engaged in the header legs and are contacting the support plates.

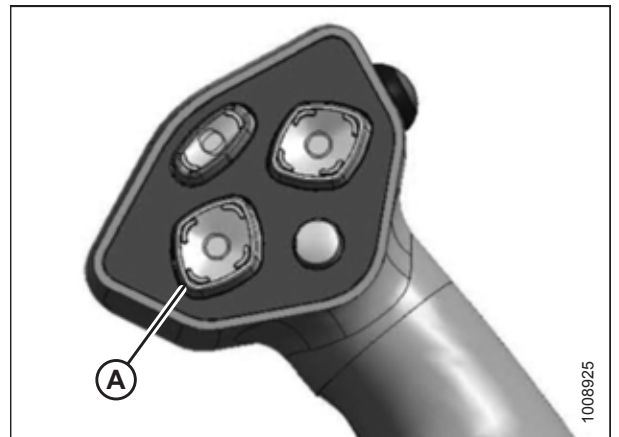

Figure 4.194: Ground Speed Lever

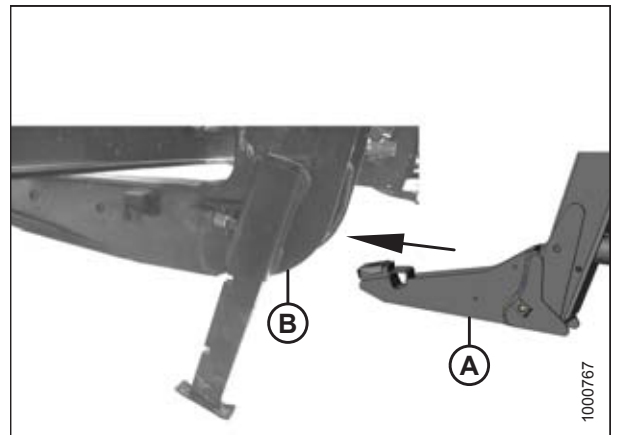

Figure 4.195: Header Leg and Boot

OPERATION

6. Stop engine and remove key from ignition.
7. Loosen nut (A) and rotate barrel (B) to adjust length until the link is aligned with the header bracket.
8. Install clevis pin (C) and secure with cotter pin (D).
9. Adjust length of link to achieve proper header angle by rotating barrel (B). Tighten nut (A) against barrel (a slight tap with a hammer is sufficient).

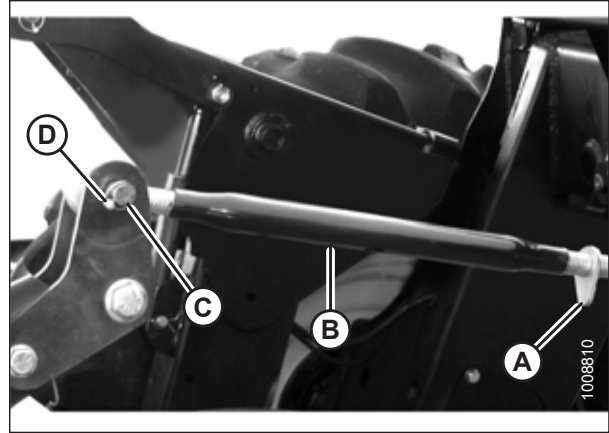

Figure 4.196: Mechanical Center Link

10. Start the engine.
11. Press HEADER UP switch (A) to raise header to maximum height.
12. If one end of the header does **NOT** fully raise, rephase the lift cylinders as follows:
 - a. Press and hold the HEADER UP switch until both cylinders stop moving.
 - b. Continue to hold the switch for 3–4 seconds. Cylinders are now phased.

NOTE:

It may be necessary to repeat this procedure if there is air in the system.



Figure 4.197: Ground Speed Lever

OPERATION

13. Engage the safety props on both lift cylinders as follows:
 - a. Shut down the engine, and remove the key from the ignition.
 - b. Pull lever (A) and rotate it towards the header to release and lower safety prop (B) onto the lift cylinder.
 - c. Repeat for opposite lift cylinder.

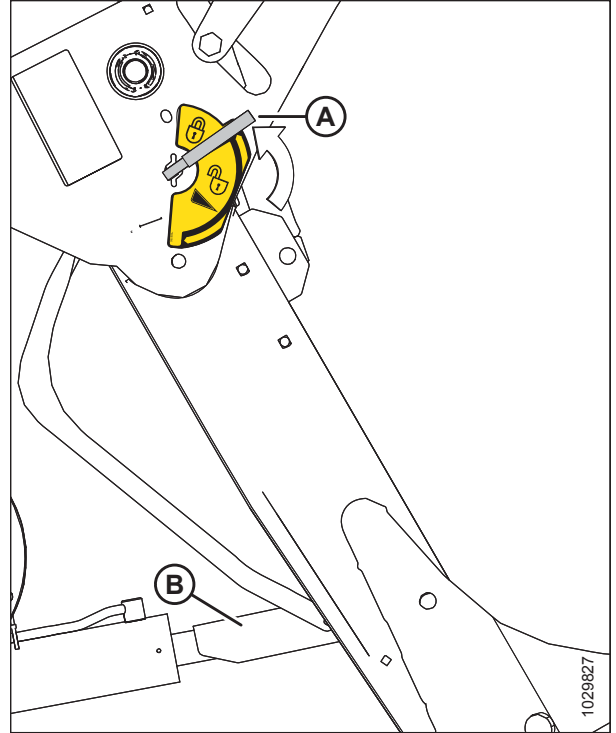

Figure 4.198: Safety Prop

14. Install clevis pin (A) through support and foot, and secure with hairpin. Repeat for opposite support.

IMPORTANT:

Ensure clevis pin (A) is fully inserted and hairpin is installed behind bracket.

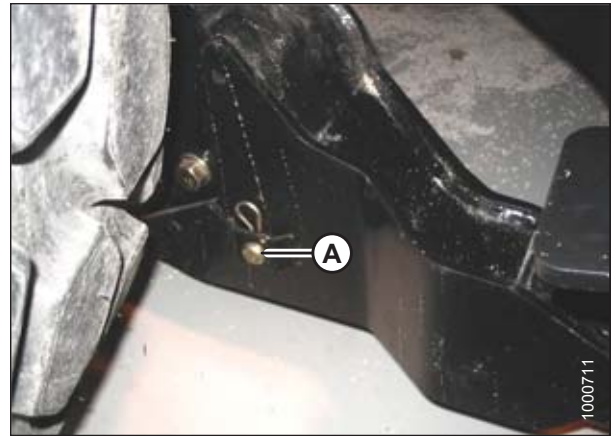

Figure 4.199: Header Support

OPERATION

15. Remove lynch pin from clevis pin (A) in stand (B).
16. Hold stand (B) and remove pin (A).
17. Move stand (B) to storage position by inverting and relocating onto bracket as shown. Reinsert clevis pin (A) and secure with lynch pin.

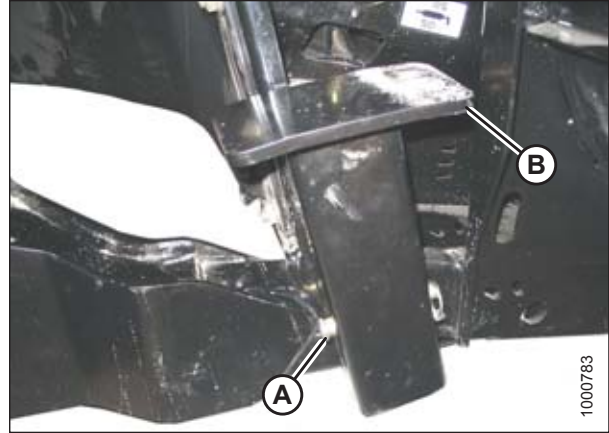

Figure 4.200: Header Stand

18. Remove the clevis pin from storage position (B) in linkage and insert into hole (A) to engage the float springs. Secure with hairpin.

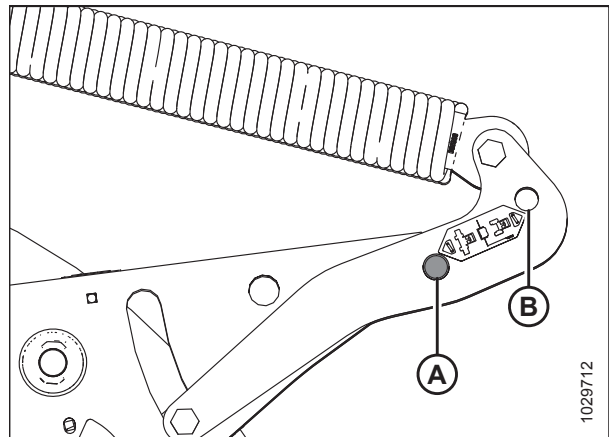

Figure 4.201: Header Float Linkage

19. Disengage the safety prop by turning lever (A) downwards until lever locks into vertical position.
20. Repeat for opposite safety prop.

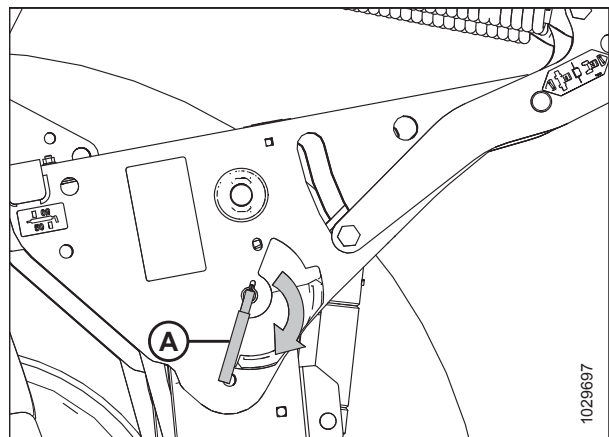

Figure 4.202: Safety Prop Lever

OPERATION

21. Connect header drive hoses (A) and electrical harness (B) to header. For instructions, refer to the header operator's manual.

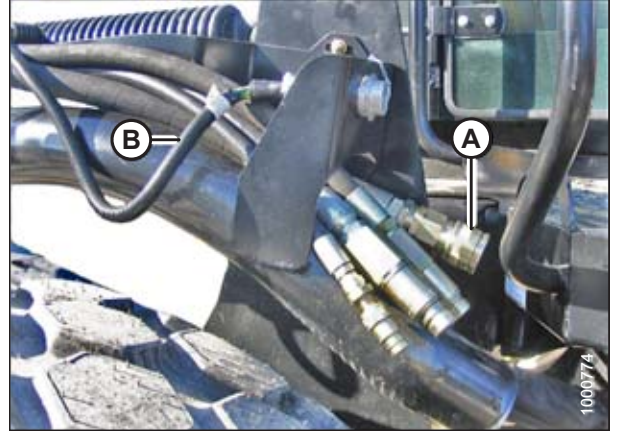

Figure 4.203: Header Drive Hoses and Harness

22. Connect reel hydraulics (A) at right cab-forward side of windrower. For instructions, refer to the draper header operator's manual.

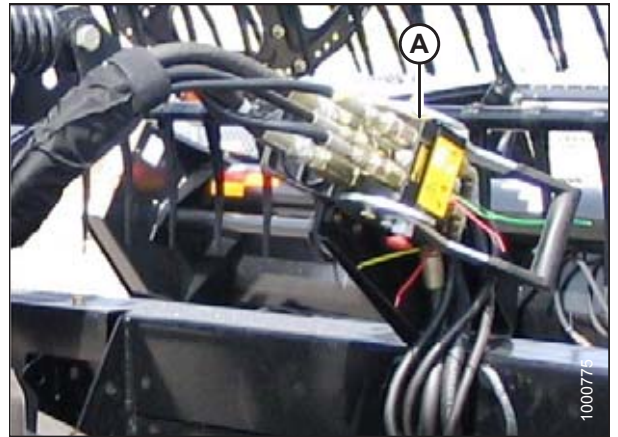

Figure 4.204: Reel Hydraulics

4.5.5 Detaching an A Series Header

Refer to the procedure applicable to the center-link installed on the windrower:

- *Detaching an A Series Header – Hydraulic Center-Link, page 260*
- *Detaching an A Series Header – Mechanical Center-Link, page 263*

Detaching an A Series Header – Hydraulic Center-Link

WARNING

To avoid bodily injury or death from unexpected startup of the machine, always stop the engine and remove the key from the ignition before leaving the operator's seat for any reason.

1. Start the engine and press HEADER UP switch (A) on the ground speed lever (GSL) to raise the header to maximum height.
2. If one end of the header does **NOT** raise fully, rephase the cylinders as follows:
 - a. Press and hold the HEADER UP switch (A) until both cylinders stop moving.
 - b. Continue to hold the switch for 3–4 seconds. Cylinders are now phased.
3. Stop the engine and remove the key.



Figure 4.205: Ground Speed Lever

DANGER

To avoid bodily injury from fall of raised header, always engage safety props when working on or around raised header, and before going under header for any reason.

4. Pull lever (A) and rotate it toward the header to lower safety prop (B) onto the cylinder. Repeat for the opposite cylinder.

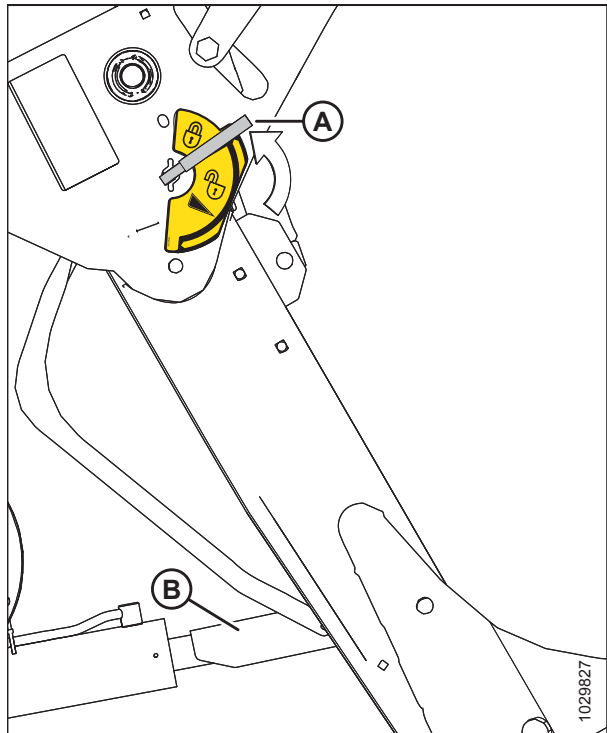

Figure 4.206: Safety Prop

OPERATION

5. Remove the hairpin from clevis pin (A), and remove clevis pin from header boots (B) on both sides.

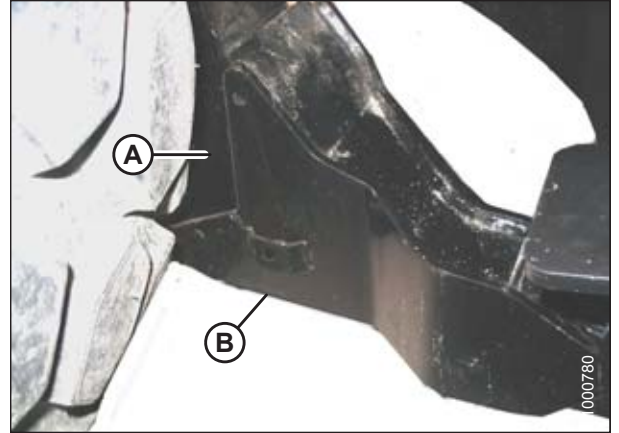

Figure 4.207: Header Boot

6. Lower stand (A) by pulling clevis pin (B), inverting stand, and relocating on bracket. Reinsert pin (B) and secure with hairpin.

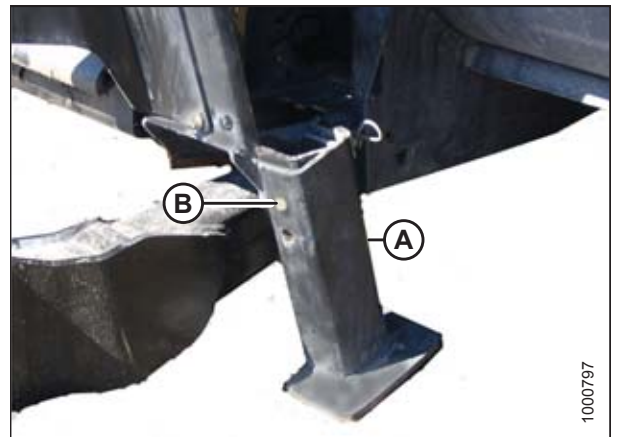

Figure 4.208: Header Stand

CAUTION

To prevent damage to the lift system when lowering header lift linkages without a header or weight box attached to the windrower, ensure the float engagement pin is installed in storage position (B) and NOT in engaged position (A).

7. Remove the lynch pin from the clevis pin, and remove the clevis pin from engaged position (A) in the linkage to disengage the float springs.
8. Insert clevis pin into storage hole (B). Secure with lynch pin. Repeat for opposite linkage.

CAUTION

Check to be sure all bystanders have cleared the area.

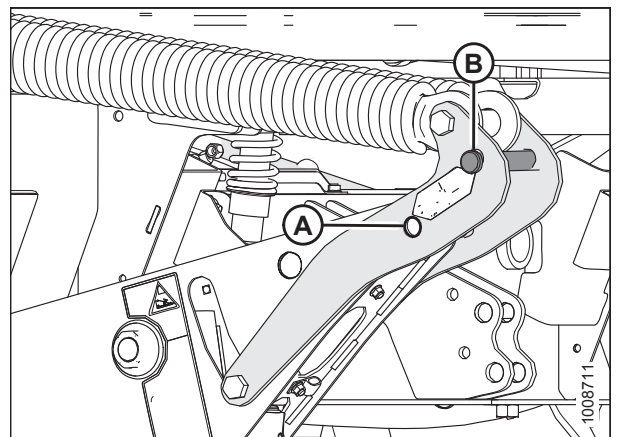

Figure 4.209: Header Float Linkage

OPERATION

- Disengage safety props by turning lever (A) away from header to raise safety prop until lever locks into vertical position. Repeat for opposite cylinder.
- Start the engine, choose a level area, and lower the header to the ground.

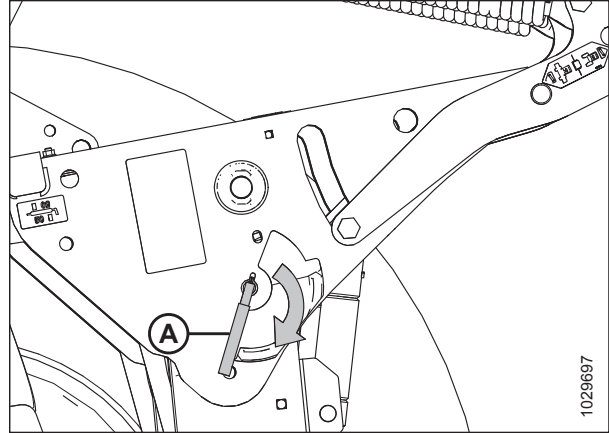

Figure 4.210: Safety Props

- Activate HEADER TILT UP (A) and HEADER TILT DOWN (B) cylinder switches on the GSL to release load on center-link cylinder.

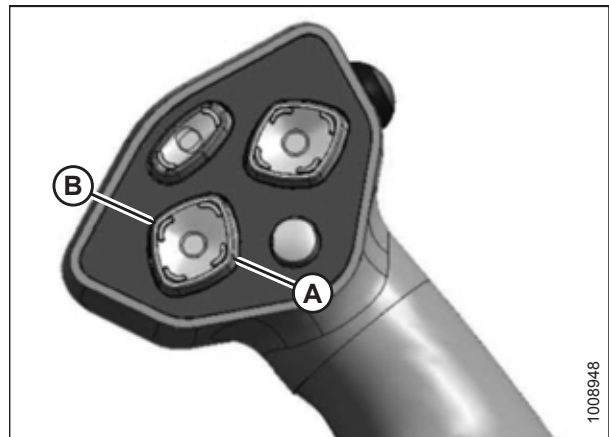

Figure 4.211: Ground Speed Lever

- Stop the engine and remove the key from the ignition.
- Lift hook release (C) and lift hook (B) off header pin.

NOTE:

If optional center-link self-alignment kit is installed, lift release (C) and then operate the link lift cylinder (A) with REEL UP switch on the GSL to disengage the center-link from the header.

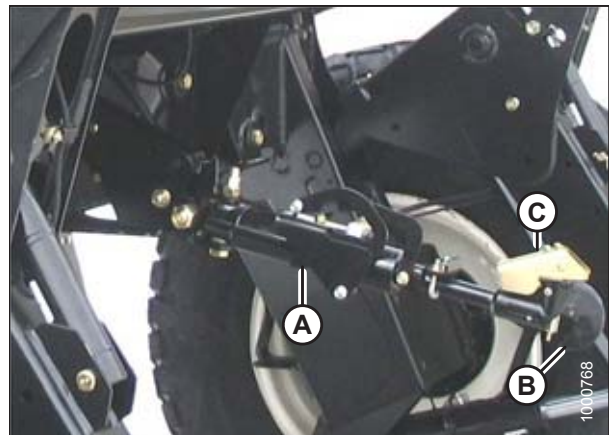

Figure 4.212: Hydraulic Center-Link

OPERATION

14. Disconnect header drive hydraulics (A) and electrical harness (B). Refer to the auger header operator's manual.
15. Back the windrower slowly away from the header.

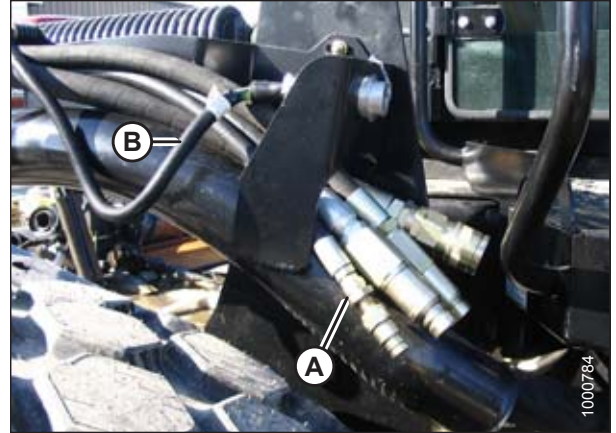

Figure 4.213: Header Drive Hydraulics

16. Reinstall clevis pin (B) into header boot (C) and secure with hairpin (A). Repeat for opposite side.

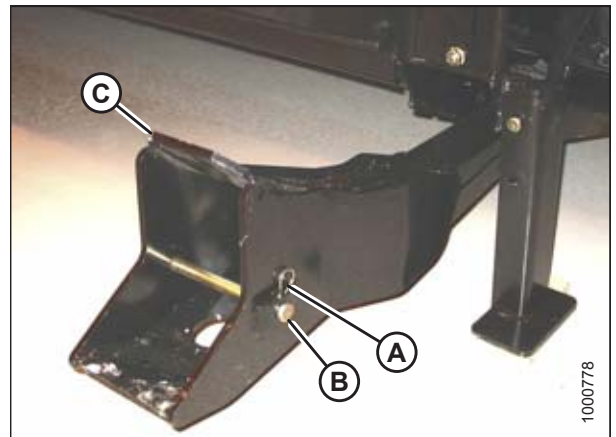

Figure 4.214: Header Boots

Detaching an A Series Header – Mechanical Center-Link

WARNING

To avoid bodily injury or death from unexpected startup of the machine, always stop the engine and remove the key from the ignition before leaving the operator's seat for any reason.

1. Start engine and press HEADER UP switch (A) on ground speed lever (GSL) to raise header to maximum height.
2. If one end of the header does **NOT** raise fully follow these steps to rephase the cylinders:
 - a. Press and hold the HEADER UP (A) switch until both cylinders stop moving.
 - b. Continue to hold the switch for 3–4 seconds. Cylinders are phased.
3. Stop engine and remove key.



Figure 4.215: Ground Speed Lever

OPERATION

DANGER

To avoid bodily injury from fall of raised header, always engage safety props when working on or around raised header, and before going under header for any reason.

4. Pull lever (A) and rotate it toward the header to lower safety prop (B) onto the cylinder. Repeat for the opposite cylinder.

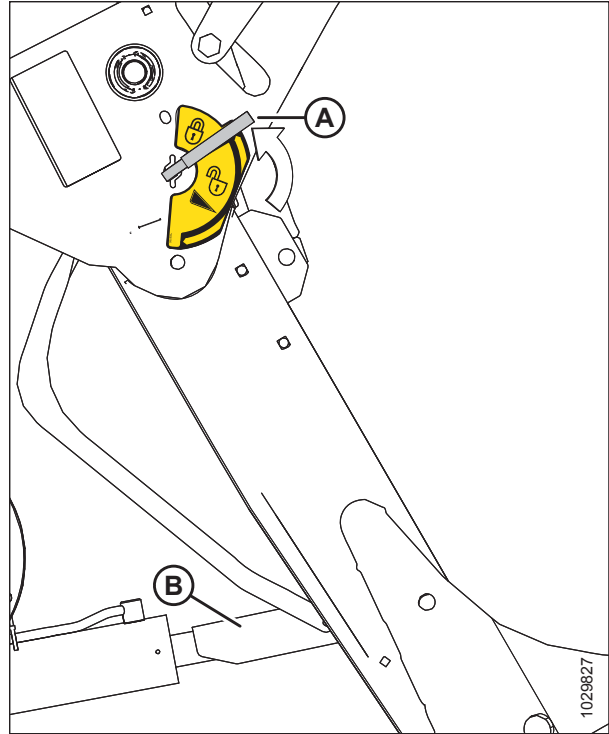

Figure 4.216: Safety Prop

5. Remove hairpin from clevis pin (A) and remove clevis pin from the left and right header boots (B).

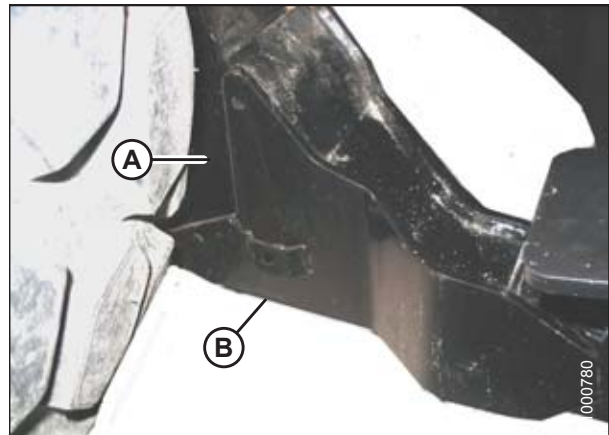

Figure 4.217: Header Boot

OPERATION

6. Lower the header stand (A) by pulling clevis pin (B), inverting stand, and relocating on bracket. Reinsert clevis pin (B) and secure with hairpin.

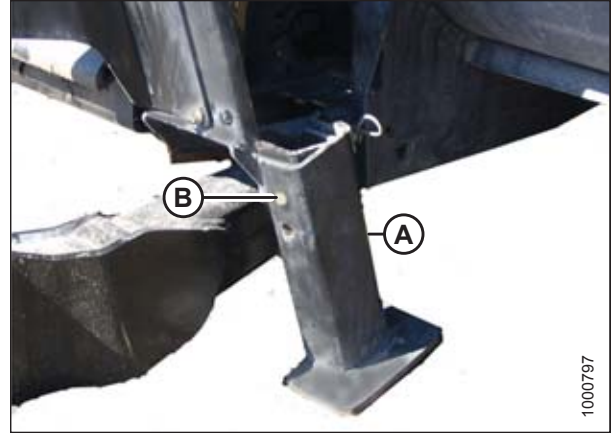

Figure 4.218: Header Stand

7. Remove clevis pin from linkage (A) to disengage float springs and insert in storage hole (B). Secure with lynch pin. Repeat for opposite linkage.

CAUTION

To prevent damage to the lift system when lowering header lift linkages without a header or weight box attached to the windrower, ensure the float engagement pin is installed in storage position (B) and NOT in engaged position (A).

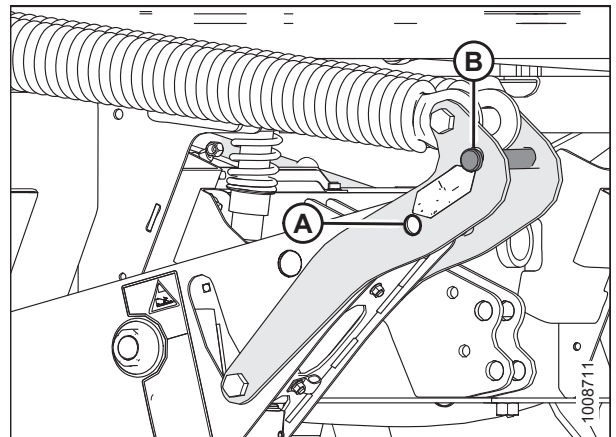

Figure 4.219: Header Float Linkage

8. Turn lever (A) away from header to raise safety prop until lever locks into vertical position. Repeat for opposite cylinder.
9. Start engine, choose a level area, and lower header to ground.
10. Stop engine, and remove key from ignition.

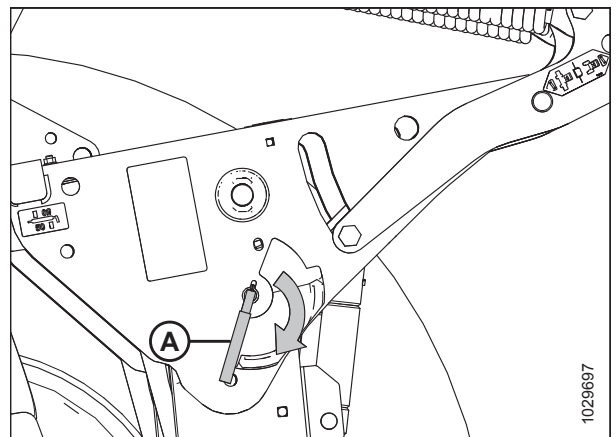

Figure 4.220: Safety Prop

OPERATION

11. Loosen nut (A) and rotate barrel (B) to relieve load on link.
12. Remove cotter pin (D) on clevis pin (C) and remove pin to disconnect from header.
13. Reinstall clevis pin in header.

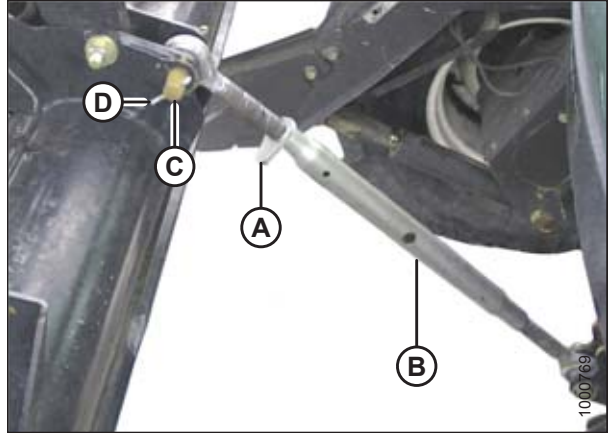

Figure 4.221: Mechanical Center-Link

14. Disconnect header drive hydraulics (A) and electrical harness (B). Refer to the auger header operator's manual.
15. Slowly back windrower away from header.

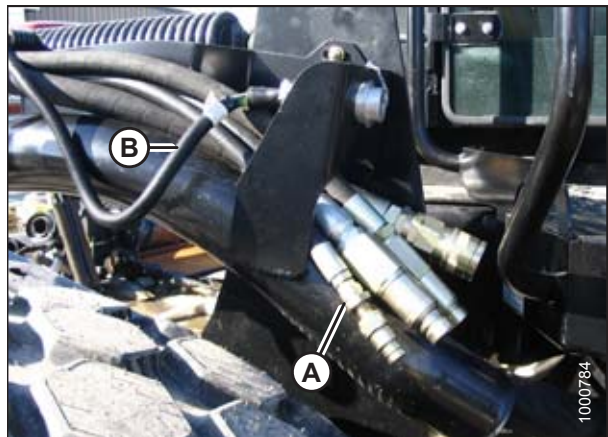

Figure 4.222: Header Drive Hydraulics

16. Reinstall clevis pin (B) and secure with hairpin (A) in header boot (C).
17. Repeat for the opposite side.

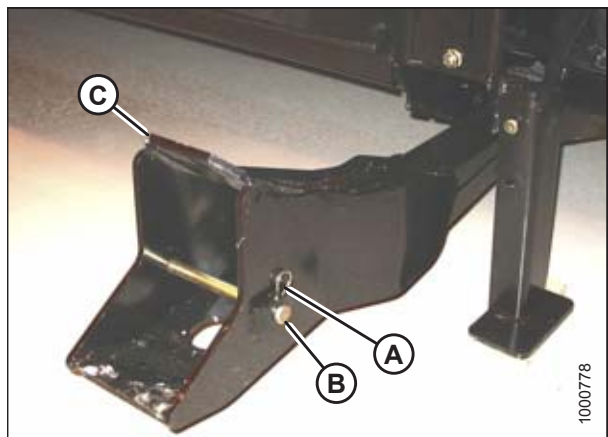

Figure 4.223: Header Boot

4.5.6 Attaching an R Series or R1 Series Header

R and R1 Series Rotary Disc Header can be attached to an M155 Self-Propelled Windrower.

NOTE:

The 18.4 x 26 drive tire is recommended on the M155 Self-Propelled Windrower when operated with a 4 m (13 ft.) R/R1 Series Rotary Disc Header. These drive tires are reversible and should be mounted inset at 3792 mm (149.3 in.) to provide maximum clearance to uncut crop. Mounting these tires outset or mounting all other drive tire options will result in windrower tires slightly wider than the header width. This may cause some uncut crop to be trampled by tires in turns and corners during windrower operation, and may leave some uncut strips of crop in the windrower's next pass.

Refer to the procedure applicable to the center-link installed on the windrower:

- [Attaching an R Series or R1 Series Header – Hydraulic Center-Link with Optional Self-Alignment, page 267](#)
- [Attaching an R Series or R1 Series Header – Hydraulic Center-Link without Optional Self-Alignment, page 272](#)

Attaching an R Series or R1 Series Header – Hydraulic Center-Link with Optional Self-Alignment

⚠ WARNING

To avoid bodily injury or death from unexpected startup of the machine, always stop the engine and remove the key from the ignition before leaving the operator's seat for any reason.

1. Shut down the engine, and remove the key from the ignition.
2. Remove hairpin (B) from clevis pin (A) and remove clevis pin from header support (C) on both sides of the header.

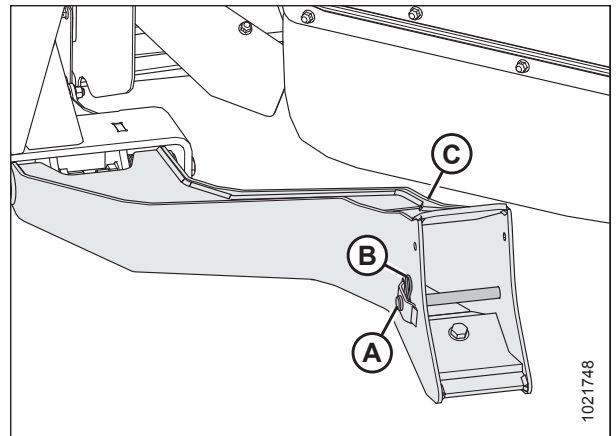

Figure 4.224: Header Support

IMPORTANT:

To prevent damage to the lift system when lowering header lift linkages without a header or weight box attached to the windrower, ensure the float engagement pin is installed in storage hole (B) and **NOT** in engaged position (A).

3. Remove the float engagement pin from hole (A) to disengage float springs, and insert float engagement pin into storage hole (B). Secure with lynch pin. Repeat for opposite linkage.

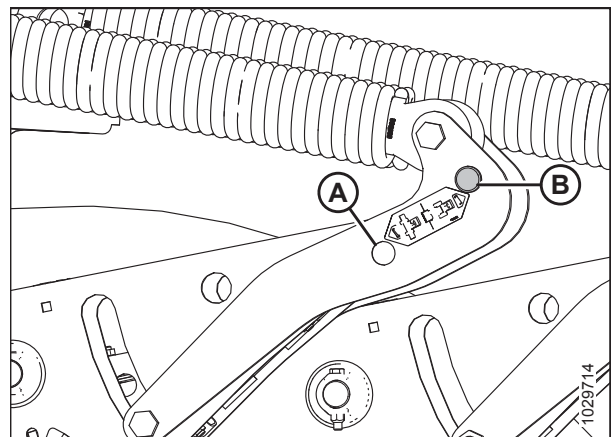

Figure 4.225: Float Linkage

OPERATION

CAUTION

Check to be sure all bystanders have cleared the area.

IMPORTANT:

Before starting engine for the first time the windrower is operated in a season, remove protective cover from exhaust stack.

4. Start the engine and activate HEADER DOWN button (A) on the ground speed lever (GSL) to fully retract header lift cylinders.

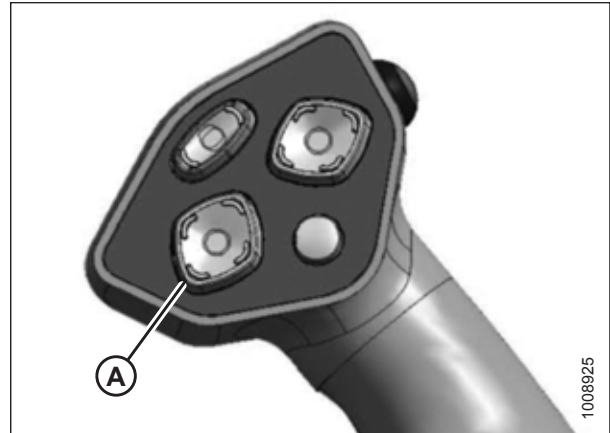

Figure 4.226: Ground Speed Lever

5. Press REEL UP switch (A) on the GSL to raise the center-link until the hook is above the attachment pin on the header.

IMPORTANT:

If the center-link is too low, it may contact the header as the windrower approaches the header for hookup.



Figure 4.227: Ground Speed Lever

6. Slowly drive the windrower forward until the windrower feet (A) enter header supports (B). Continue driving slowly forward until the feet engage the supports and the header nudges forward.

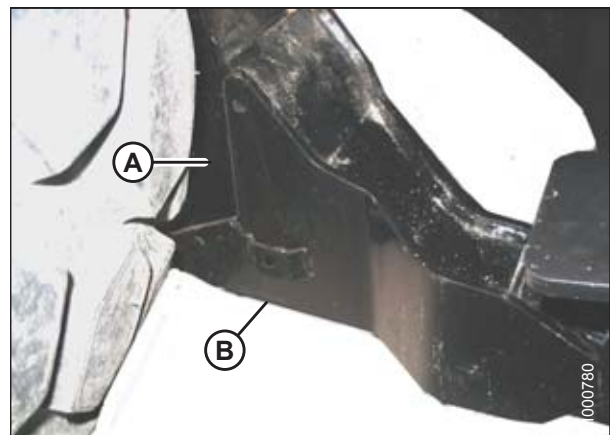

Figure 4.228: Header Support

OPERATION

7. Use the following GSL functions to position the center-link hook above the header attachment pin:
 - REEL UP (A) to raise the center-link
 - REEL DOWN (B) to lower the center-link
 - HEADER TILT UP (C) to retract the center-link
 - HEADER TILT DOWN (D) to extend the center-link

IMPORTANT:

Hook release must be down to enable self-locking mechanism. If the release is open (up), manually push it down after hook engages header pin.

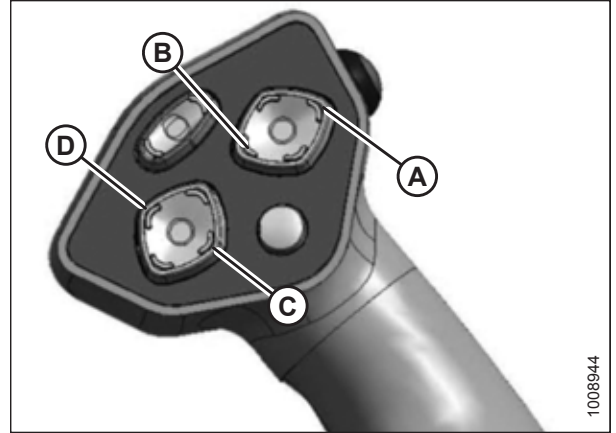

Figure 4.229: Ground Speed Lever

8. Adjust center-link cylinder (A) position with the REEL UP and REEL DOWN switches on the GSL until the hook is positioned above the header attachment pin.

IMPORTANT:

Hook release (B) must be down to enable the self-locking mechanism. If the release is open (up), manually push it down after hook engages header pin.

9. Lower center-link (A) onto the header with the REEL DOWN switch until the center-link locks into position and hook release (B) is down.
10. Check that center-link is locked onto header by pressing the REEL UP switch on the GSL.

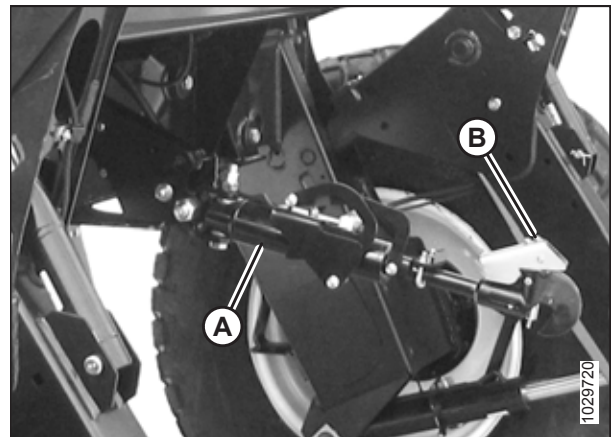

Figure 4.230: Hydraulic Center-Link

CAUTION

Check to be sure all bystanders have cleared the area.

11. Press HEADER UP switch (A) to raise the header to maximum height.
12. If one end of the header does **NOT** fully raise, rephase the lift cylinders as follows:
 - a. Press and hold the HEADER UP switch until both cylinders stop moving.
 - b. Continue to hold the switch for 3–4 seconds. Cylinders are now phased.

NOTE:

It may be necessary to repeat this procedure if there is air in the system.



Figure 4.231: Ground Speed Lever

OPERATION

13. Engage the safety props on both lift cylinders as follows:
 - a. Shut down the engine, and remove the key from the ignition.
 - b. Pull lever (A) and rotate it towards the header to release and lower safety prop (B) onto the lift cylinder.
 - c. Repeat for opposite lift cylinder.

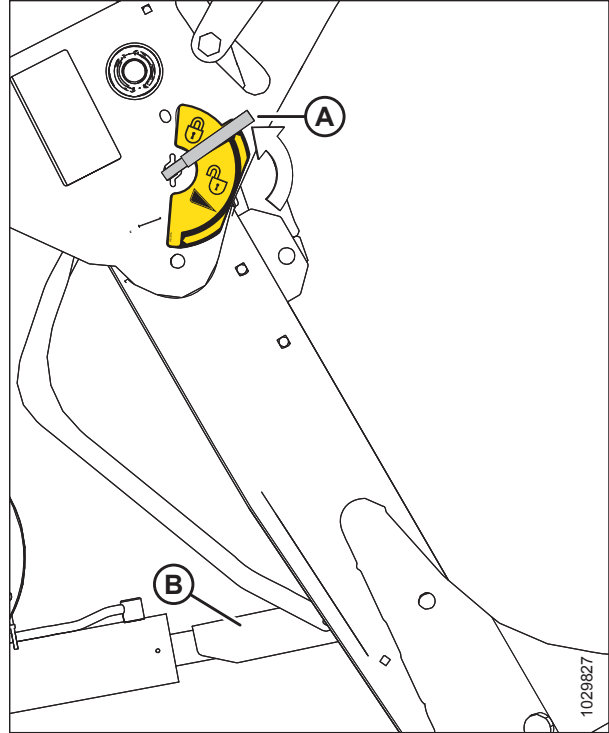

Figure 4.232: Safety Prop

14. Install clevis pin (A) through support and windrower lift member, and secure with hairpin (B). Repeat for the opposite side of the machine.

IMPORTANT:

Ensure clevis pin (A) is fully inserted and hairpin is installed behind bracket.

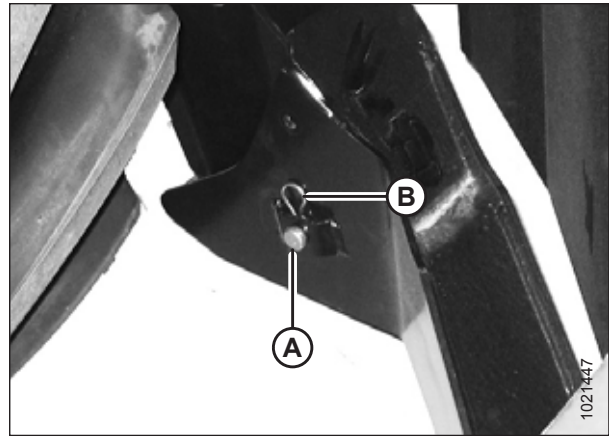

Figure 4.233: Header Support

OPERATION

15. Remove the clevis pin from storage position (B) in linkage and insert into hole (A) to engage the float springs. Secure with hairpin.

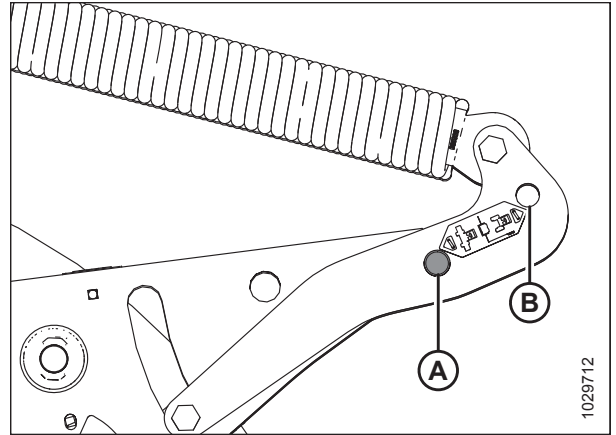

Figure 4.234: Header Float Linkage

16. Disengage the safety prop by turning lever (A) downwards until lever locks into vertical position.
17. Repeat for opposite safety prop.

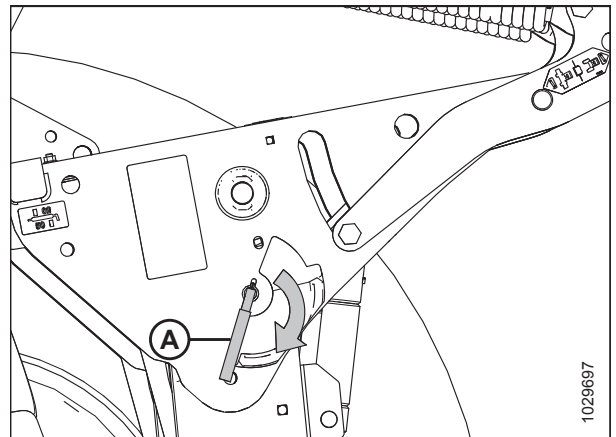

Figure 4.235: Safety Prop Lever

CAUTION

Check to be sure all bystanders have cleared the area.

18. Start the engine and press HEADER DOWN switch (A) on the GSL to fully lower the header.
19. Stop the engine and remove key from ignition.

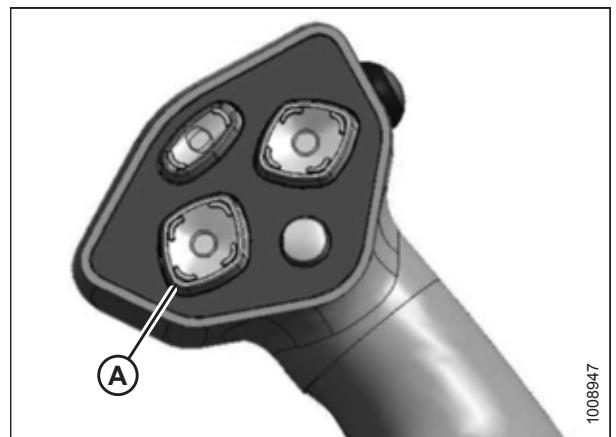

Figure 4.236: Ground Speed Lever

OPERATION

20. Connect header drive hoses (A) and electrical harness (B) to header. For instructions, refer to the header operator's manual.

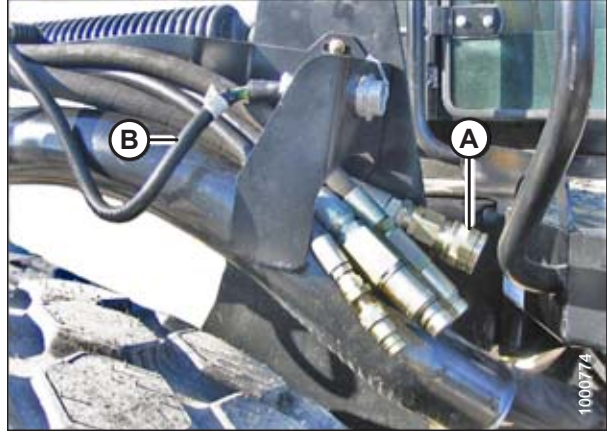

Figure 4.237: Header Drive Hoses and Harness

Attaching an R Series or R1 Series Header – Hydraulic Center-Link without Optional Self-Alignment

WARNING

To avoid bodily injury or death from unexpected startup of the machine, always stop the engine and remove the key from the ignition before leaving the operator's seat for any reason.

1. Shut down the engine, and remove the key from the ignition.
2. Remove hairpin (B) from clevis pin (A), and then remove clevis pin from header support (C) on both sides of the header.

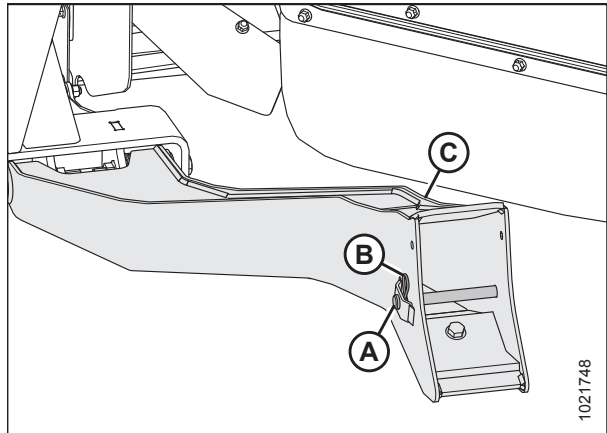

Figure 4.238: Header Support

IMPORTANT:

To prevent damage to the lift system when lowering header lift linkages without a header or weight box attached to the windrower, ensure the float engagement pin is installed in storage position (B) and **NOT** in engaged position (A).

3. To disengage float springs, move the float engagement pin from engaged position (A) and insert pin into storage hole (B). Secure float engagement pin with lynch pin. Repeat for opposite linkage.

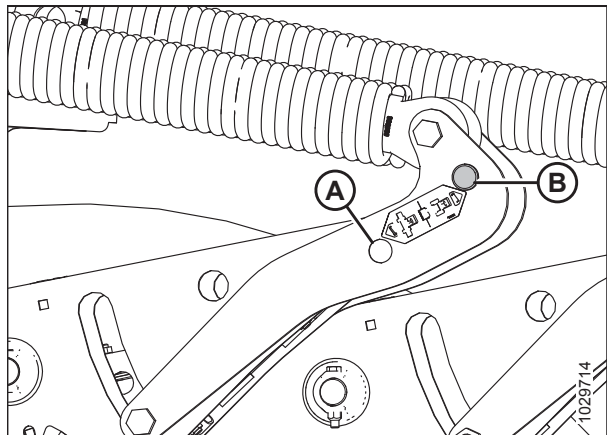

Figure 4.239: Header Float Linkage

CAUTION

Check to be sure all bystanders have cleared the area.

IMPORTANT:

Before starting engine for the first time the windrower is operated in a season, remove protective cover from exhaust stack.

4. Start the engine and activate HEADER DOWN button (A) on the ground speed lever (GSL) to fully retract header lift cylinders.

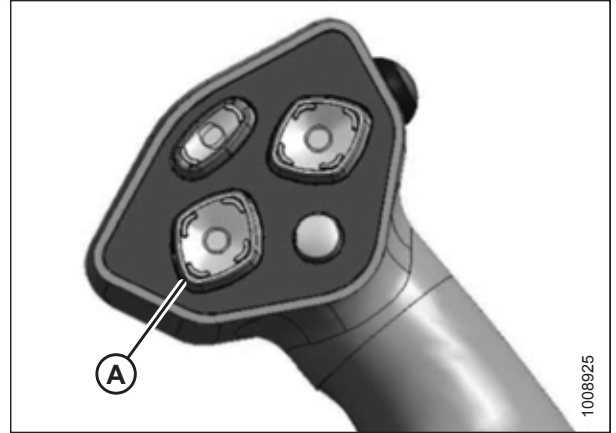

Figure 4.240: Ground Speed Lever

5. Remove pin (A) from frame linkage and raise center-link (B) until hook is above the attachment pin on header. Replace pin (A) to hold center-link in place.

IMPORTANT:

If the center-link is too low, it may contact the header as the windrower approaches the header for hookup.

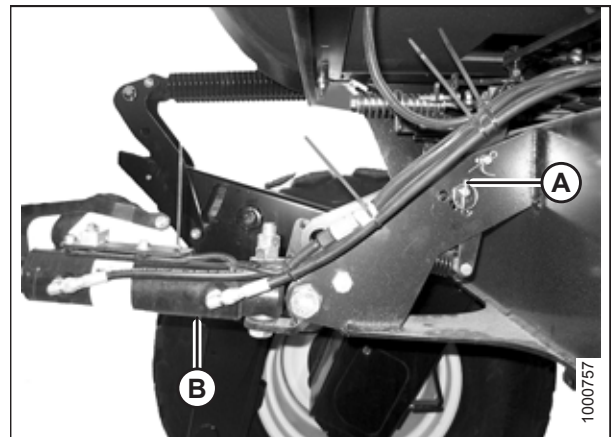

Figure 4.241: Hydraulic Center-Link without Self-Alignment Kit

6. Slowly drive the windrower forward until the windrower feet (A) enter header supports (B). Continue driving slowly forward until the feet engage the supports and the header nudges forward.

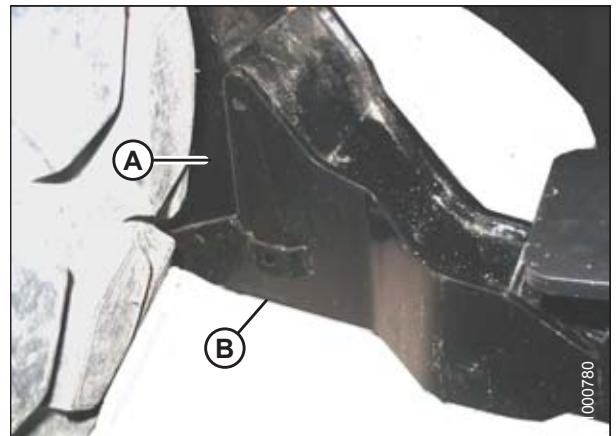

Figure 4.242: Header Support

OPERATION

7. Use the following GSL functions to position the center-link hook above the header attachment pin:
 - HEADER TILT UP (A) to retract the center-link
 - HEADER TILT DOWN (B) to extend the center-link
8. Stop engine, and remove key from ignition.

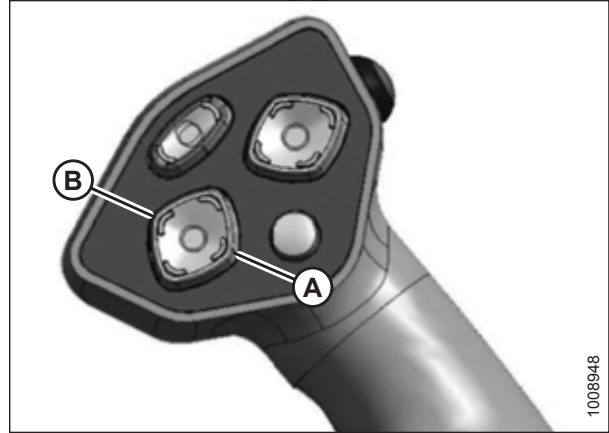

Figure 4.243: Ground Speed Lever

9. Push down on rod end of link cylinder (A) until hook (B) engages and locks onto header pin.

IMPORTANT:

The hook release must be down to enable the self-locking mechanism. If the release is open (up), manually push it down after hook engages header pin.

10. Check that center-link (A) is locked onto the header by pulling upward on rod end (B) of cylinder.

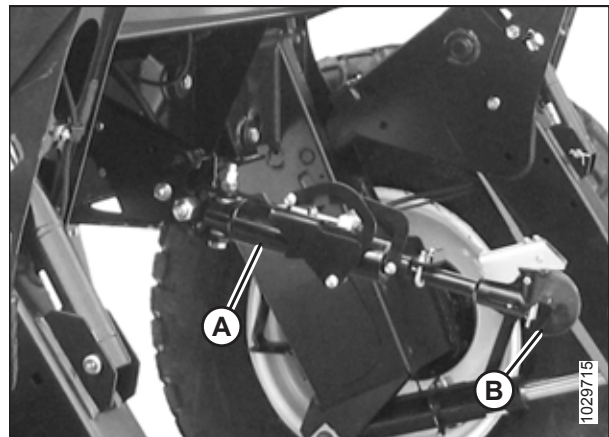

Figure 4.244: Hydraulic Center-Link

CAUTION

Check to be sure all bystanders have cleared the area.

11. Start the engine.
12. Press HEADER UP switch (A) to raise the header to maximum height.
13. If one end of the header does **NOT** fully raise, rephase the lift cylinders as follows:
 - a. Press and hold the HEADER UP switch until both cylinders stop moving.
 - b. Continue to hold the switch for 3–4 seconds. Cylinders are now phased.

NOTE:

It may be necessary to repeat this procedure if there is air in the system.



Figure 4.245: Ground Speed Lever

OPERATION

14. Engage the safety props on both lift cylinders as follows:
 - a. Shut down the engine, and remove the key from the ignition.
 - b. Pull lever (A) and rotate it towards the header to release and lower safety prop (B) onto the lift cylinder.
 - c. Repeat for opposite lift cylinder.

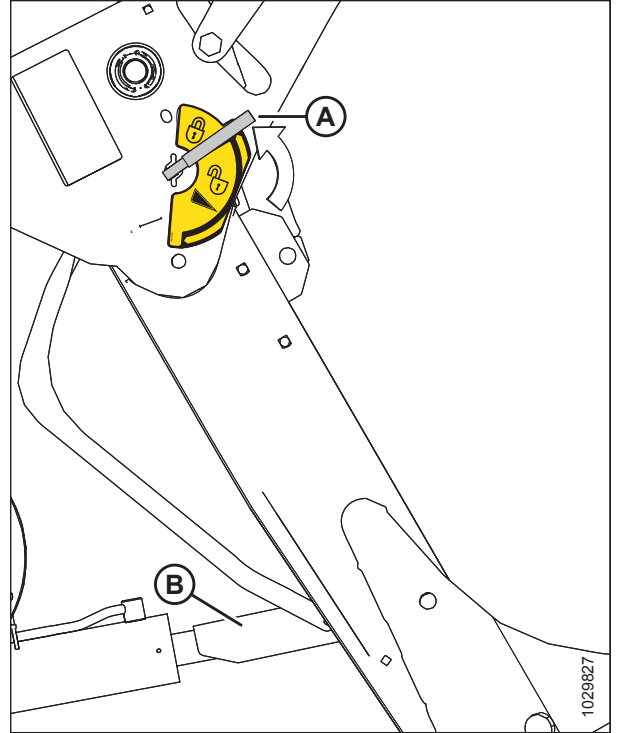

Figure 4.246: Safety Prop

15. Install clevis pin (A) through the support and windrower lift member, and secure with hairpin (B). Repeat for the opposite side of the machine.

IMPORTANT:

Ensure clevis pin (A) is fully inserted and hairpin is installed behind bracket.

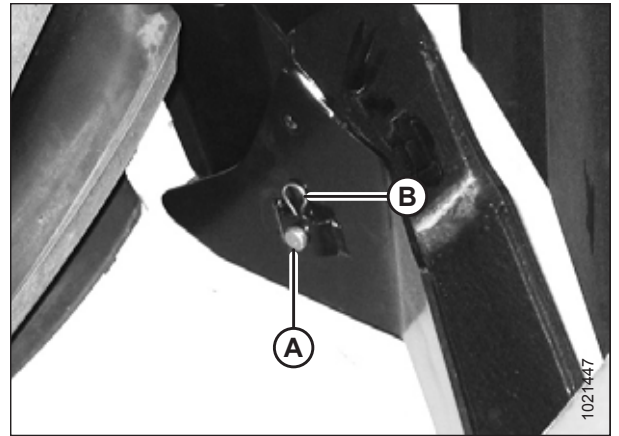

Figure 4.247: Header Support

OPERATION

16. Remove the clevis pin from storage position (B) in linkage and insert into hole (A) to engage the float springs. Secure with hairpin.

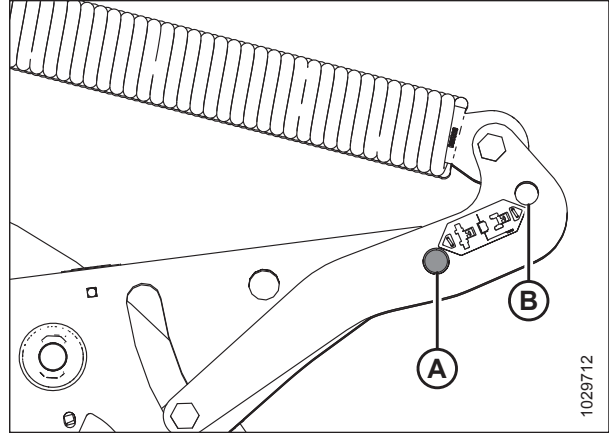

Figure 4.248: Header Float Linkage

17. Disengage the safety prop by turning lever (A) downwards until lever locks into vertical position.
18. Repeat for opposite safety prop.

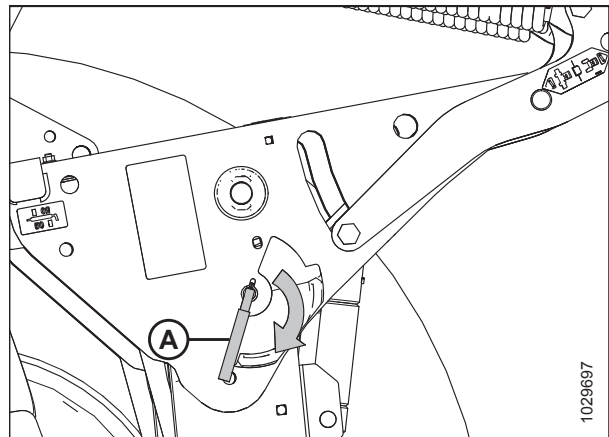

Figure 4.249: Safety Prop Lever

CAUTION

Check to be sure all bystanders have cleared the area.

19. Start the engine and press HEADER DOWN switch (A) on the GSL to fully lower the header.
20. Stop the engine and remove key from ignition.

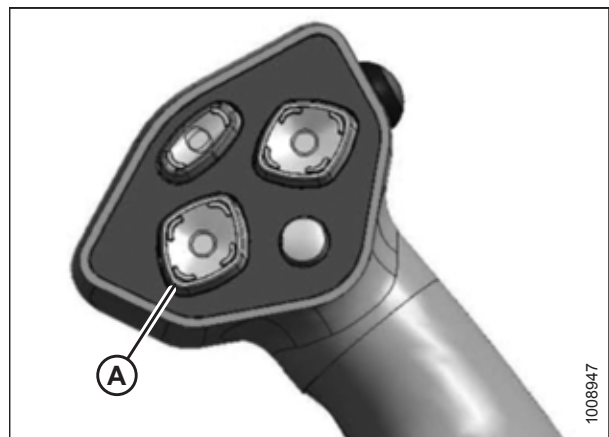

Figure 4.250: Ground Speed Lever

OPERATION

21. Connect header drive hoses (A) and electrical harness (B) to header. For instructions, refer to the header operator's manual.

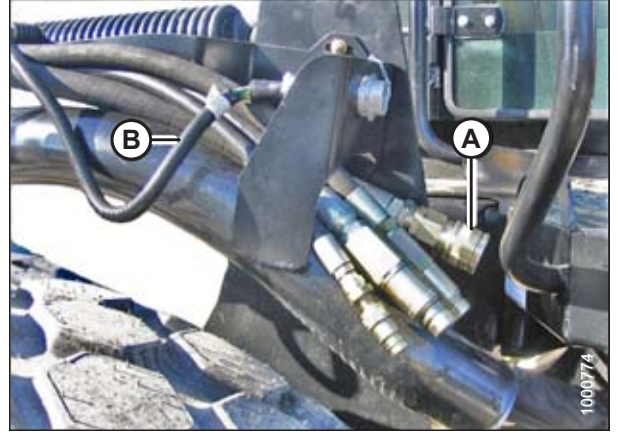

Figure 4.251: Header Drive Hoses and Harness

Attaching an R Series or R1 Series Header – Mechanical Center-Link

WARNING

To avoid bodily injury or death from unexpected startup of the machine, always stop the engine and remove the key from the ignition before leaving the operator's seat for any reason.

1. Shut down the engine, and remove the key from the ignition.
2. Remove hairpin (B) from clevis pin (A) and remove clevis pin from the header supports (C) on both sides of the header.

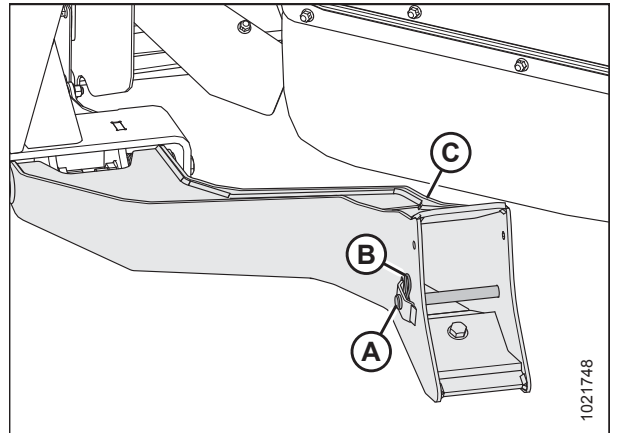

Figure 4.252: Header Support

CAUTION

To prevent damage to the lift system when lowering header lift linkages without a header or weight box attached to the windrower, ensure the float engagement pin is installed in storage position (B) and NOT in engaged position (A).

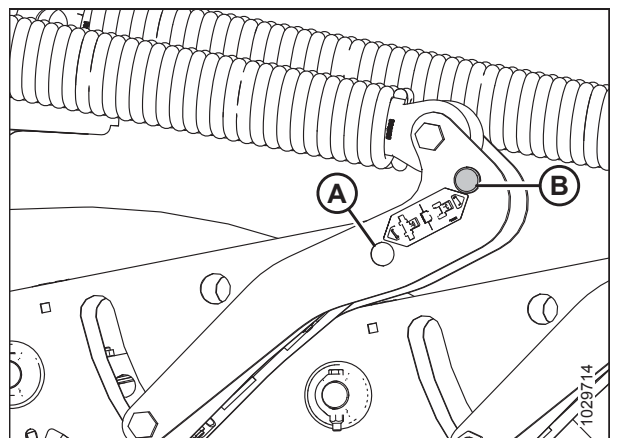

Figure 4.253: Header Float Linkage

OPERATION

CAUTION

Check to be sure all bystanders have cleared the area.

IMPORTANT:

Before starting engine for the first time the windrower is operated in a season, remove protective cover from exhaust stack.

3. Start the engine and activate HEADER DOWN button (A) on the ground speed lever (GSL) to fully retract header lift cylinders.
4. Drive the windrower slowly forward until the windrower feet (A) enter the header supports (B). Continue driving slowly forward until the feet engage the supports and the header nudges forward.
5. Stop engine and remove key from ignition.
6. Loosen nut (A) and rotate barrel (B) to adjust length until the link is aligned with the header bracket.
7. Install clevis pin (C) and secure with cotter pin (D).
8. Adjust length of link to achieve proper header angle by rotating barrel (B). Tighten nut (A) against barrel (a slight tap with a hammer is sufficient).

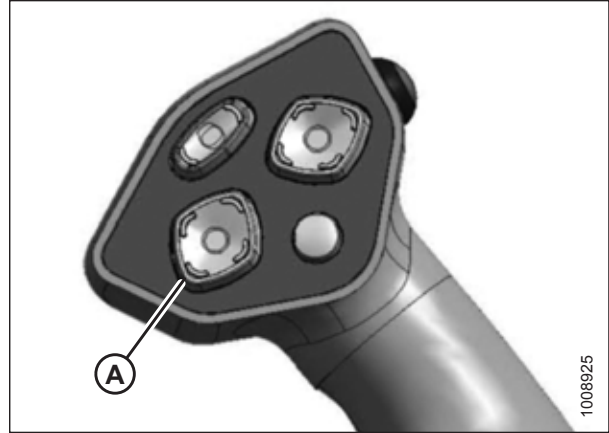

Figure 4.254: Ground Speed Lever

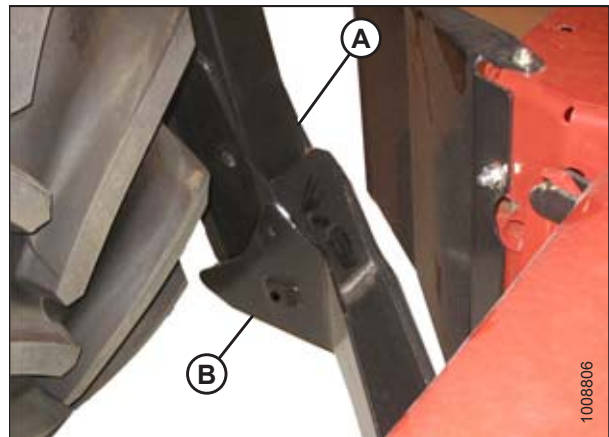

Figure 4.255: Header Support

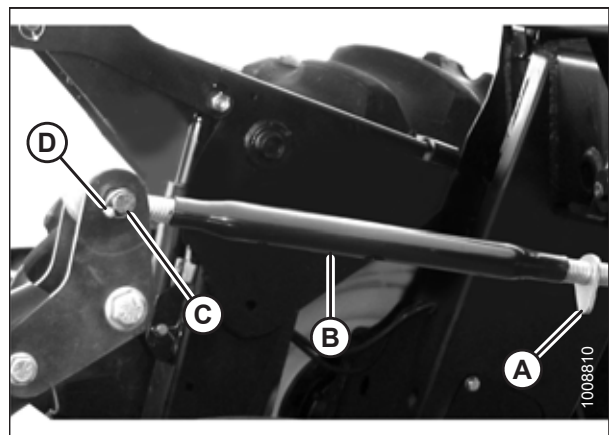

Figure 4.256: Mechanical Center-Link

OPERATION

CAUTION

Check to be sure all bystanders have cleared the area.

9. Start the engine.
10. Press the HEADER UP switch (A) to raise header to maximum height.
11. If one end of the header does **NOT** fully raise, rephase the lift cylinders as follows:
 - a. Press and hold the HEADER UP switch until both cylinders stop moving.
 - b. Continue to hold the switch for 3–4 seconds. Cylinders are now phased.

NOTE:

It may be necessary to repeat this procedure if there is air in the system.

12. Engage the safety props on both lift cylinders as follows:
 - a. Shut down the engine, and remove the key from the ignition.
 - b. Pull lever (A) and rotate it towards the header to release and lower safety prop (B) onto the lift cylinder.
 - c. Repeat for opposite lift cylinder.

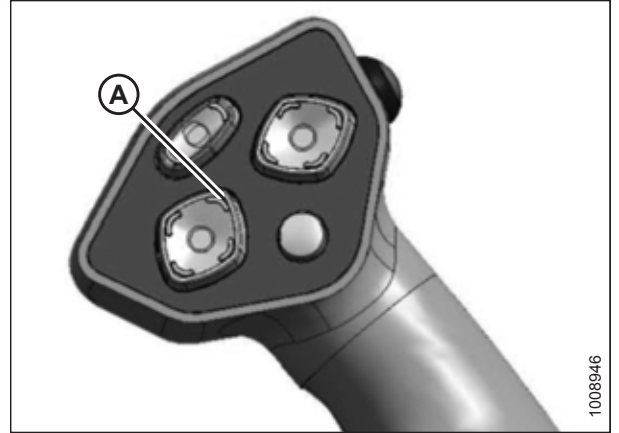

Figure 4.257: Ground Speed Lever

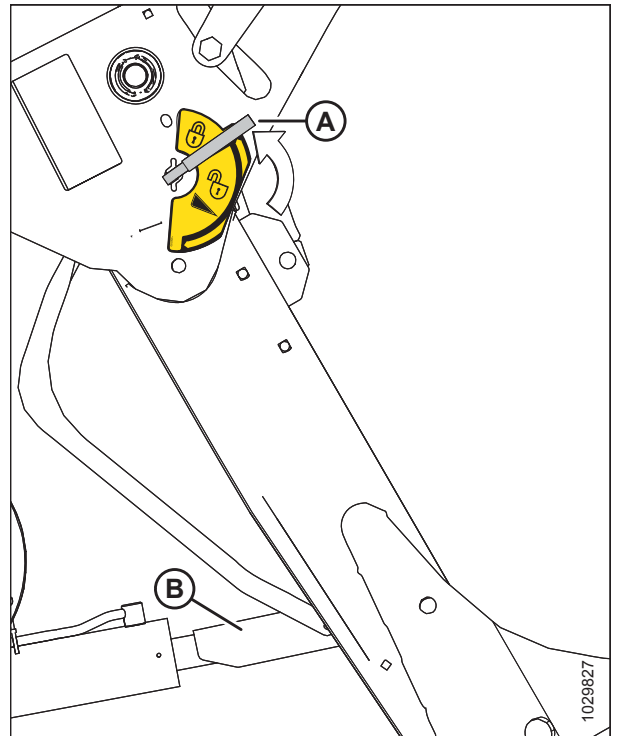

Figure 4.258: Safety Prop

OPERATION

13. Install clevis pin (A) through support and windrower lift member, and secure with hairpin (B). Repeat for opposite side.

IMPORTANT:

Ensure clevis pin (A) is fully inserted and hairpin is installed behind bracket.

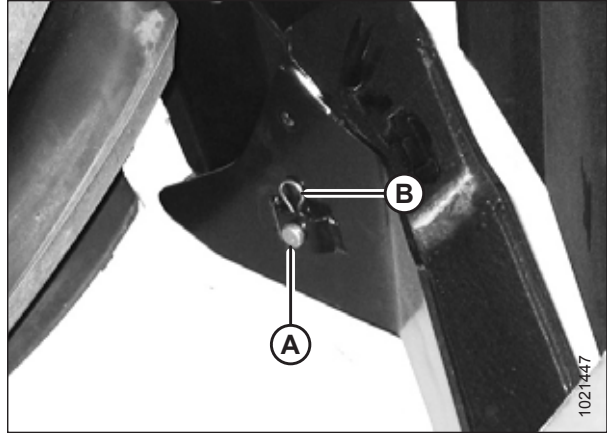

Figure 4.259: Header Support

14. Remove the clevis pin from storage position (B) in linkage and insert into hole (A) to engage the float springs. Secure with hairpin.

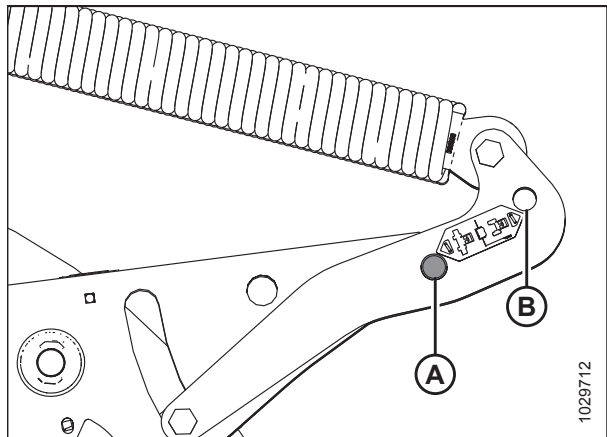

Figure 4.260: Header Float Linkage

15. Disengage the safety prop by turning lever (A) downwards until lever locks into vertical position.
16. Repeat for opposite safety prop.

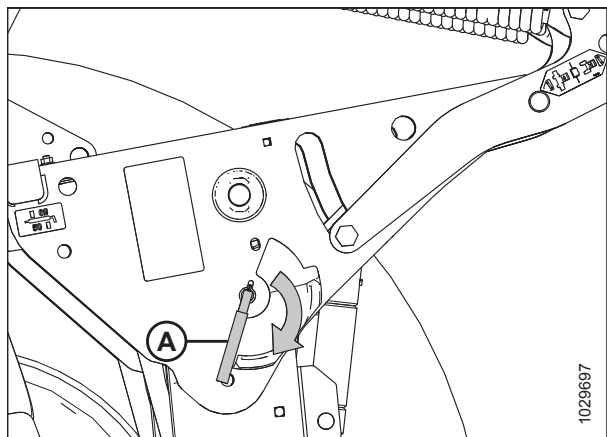

Figure 4.261: Safety Prop Lever

OPERATION

CAUTION

Check to be sure all bystanders have cleared the area.

17. Start the engine and press HEADER DOWN switch (A) on the GSL to fully lower the header.
18. Stop the engine and remove key from ignition.

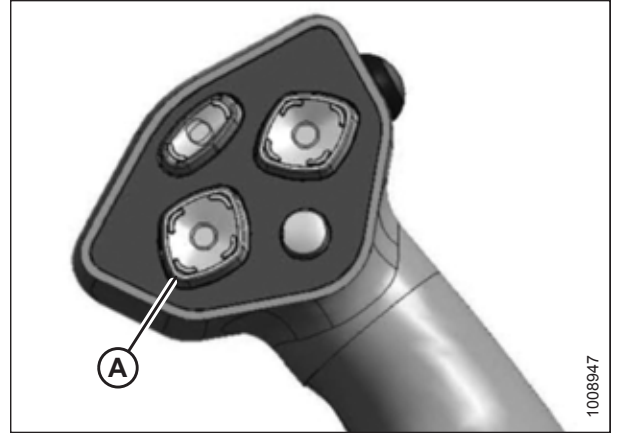

Figure 4.262: Ground Speed Lever

19. Connect header drive hoses (A) and electrical harness (B) to header. For instructions, refer to the header operator's manual.

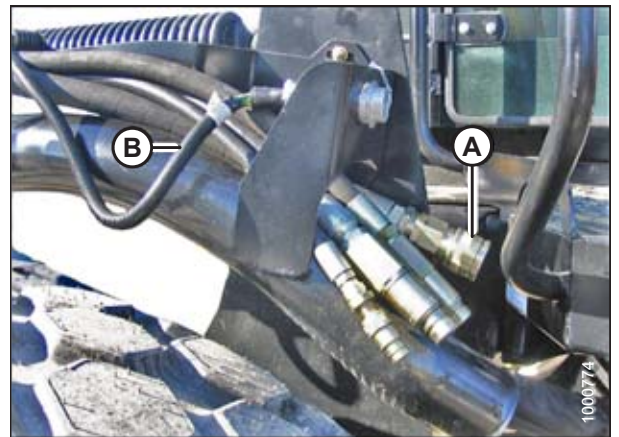

Figure 4.263: Header Drive Hoses and Harness

4.5.7 Detaching an R Series or R1 Series Header

Refer to the procedure that is applicable to the center-link installed on the windrower:

- [Detaching an R Series or R1 Series Header – Hydraulic Center-Link, page 282](#)
- [Detaching an R Series or R1 Series Header – Mechanical Center-Link, page 285](#)

Detaching an R Series or R1 Series Header – Hydraulic Center-Link

WARNING

To avoid bodily injury or death from unexpected startup of the machine, always stop the engine and remove the key from the ignition before leaving the operator's seat for any reason.

1. Start engine and press HEADER UP switch (A) to raise header to maximum height.
2. Rephase cylinders if one end of the header does not raise fully. If rephasing is required, proceed as follows:
 - a. Press and hold the HEADER UP switch (A) until both cylinders stop moving.
 - b. Continue to hold the switch for 3–4 seconds. Cylinders are now phased.



Figure 4.264: Ground Speed Lever (GSL)

3. Stop engine and remove key from ignition.
4. Pull lever (A) and rotate it toward the header to lower safety prop (B) onto the cylinder. Repeat for the opposite cylinder.

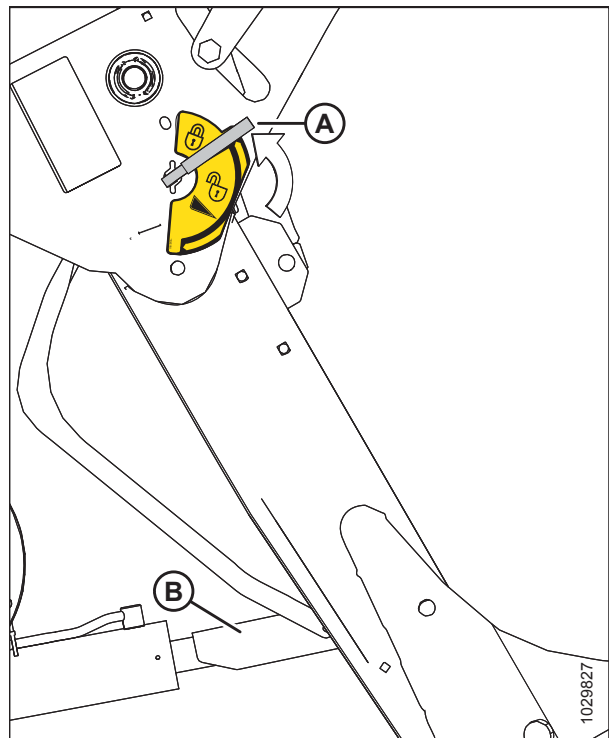

Figure 4.265: Safety Prop

OPERATION

5. Remove hairpin (B) from clevis pin (A) and remove clevis pin from header boot (C) on both sides of header.

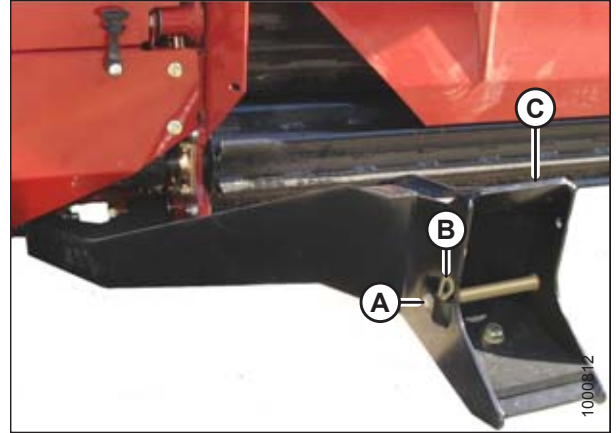

Figure 4.266: Header Boots

CAUTION

To prevent damage to the lift system when lowering header lift linkages without a header or weight box attached to the windrower, ensure the float engagement pin is installed in storage position (B) and NOT in engaged position (A).

6. Remove hairpin and clevis pin from location (A) to disengage float springs, and insert into storage hole (B). Secure with hairpin.

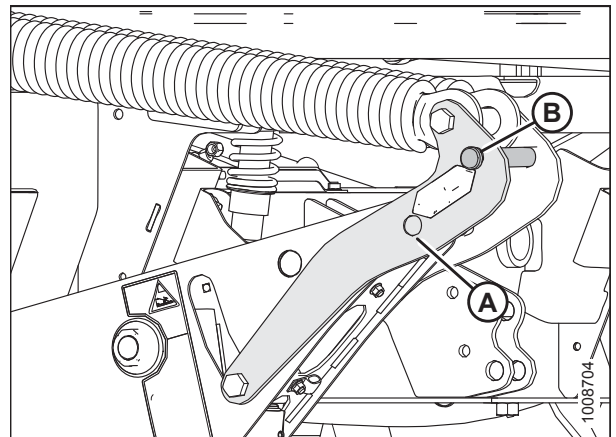

Figure 4.267: Header Float Linkage

CAUTION

Check to be sure all bystanders have cleared the area.

7. Disengage safety props by turning lever (A) away from header to raise safety prop until lever locks into vertical position. Repeat for opposite cylinder.
8. Start the engine, choose a level area, and lower the header to the ground.

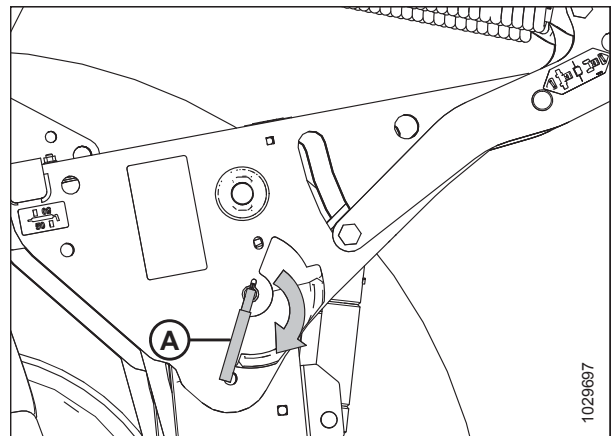

Figure 4.268: Safety Props

OPERATION

9. Press HEADER TILT UP (A) and HEADER TILT DOWN (B) cylinder switches on the GSL to release load on center-link cylinder.

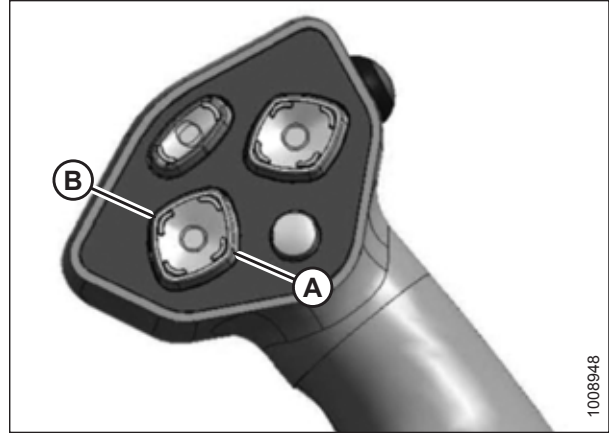

Figure 4.269: Ground Speed Lever

10. Stop the engine and remove the key from the ignition.
11. Lift hook release (C) and lift hook (B) off header pin.

NOTE:

If optional center-link lift cylinder is installed, lift release (C) and then operate the link lift cylinder from the cab to disengage the center-link (A) from the header.

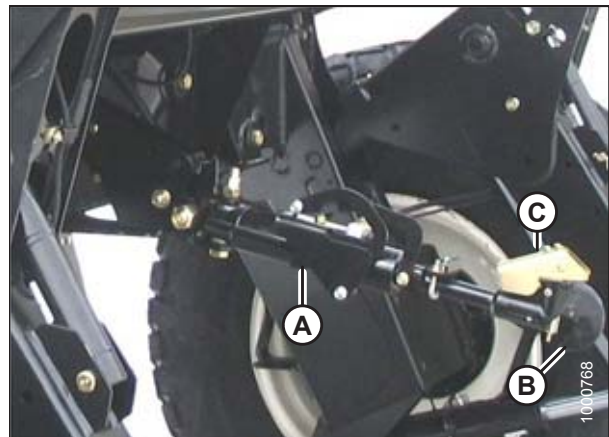

Figure 4.270: Hydraulic Center-Link

12. Disconnect header drive hydraulics (A) and electrical harness (B). Refer to the header operator's manual.
13. Back the windrower slowly away from the header.

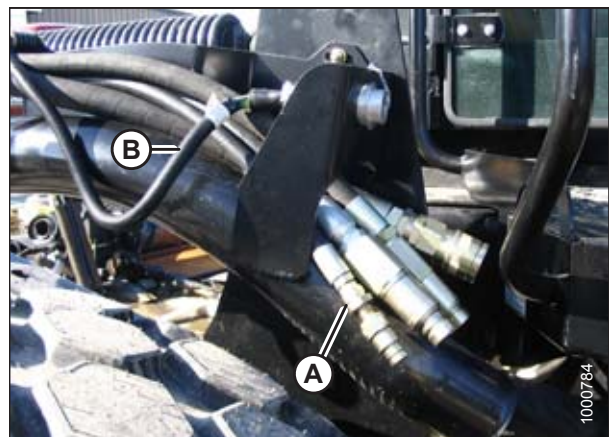

Figure 4.271: Header Drive Hydraulics

OPERATION

14. Reinstall clevis pin (A) through boot (C) and secure with hairpin (B). Repeat for opposite side.

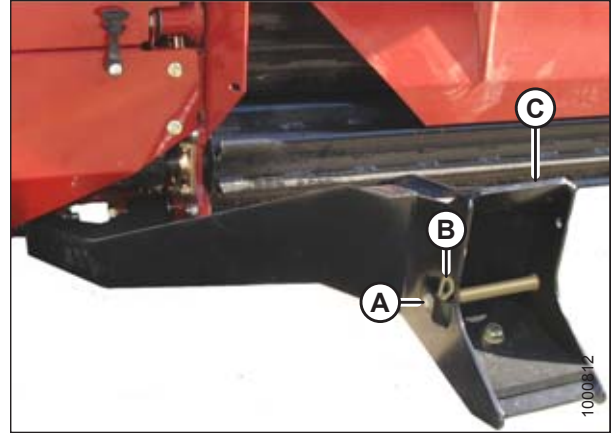

Figure 4.272: Header Boot

Detaching an R Series or R1 Series Header – Mechanical Center-Link

WARNING

To avoid bodily injury or death from unexpected startup of the machine, always stop the engine and remove the key from the ignition before leaving the operator's seat for any reason.

1. Start engine and press HEADER UP switch (A) to raise header to maximum height.
2. Rephase cylinders if one end of the header does not raise fully. If rephasing is required, proceed as follows:
 - a. Press and hold the HEADER UP switch (A) until both cylinders stop moving.
 - b. Continue to hold the switch for 3–4 seconds. Cylinders are now phased.



Figure 4.273: Ground Speed Lever (GSL)

OPERATION

3. Stop engine, and remove key from ignition.
4. Pull lever (A) and rotate toward header to lower safety prop (B) onto cylinder. Repeat for opposite cylinder.

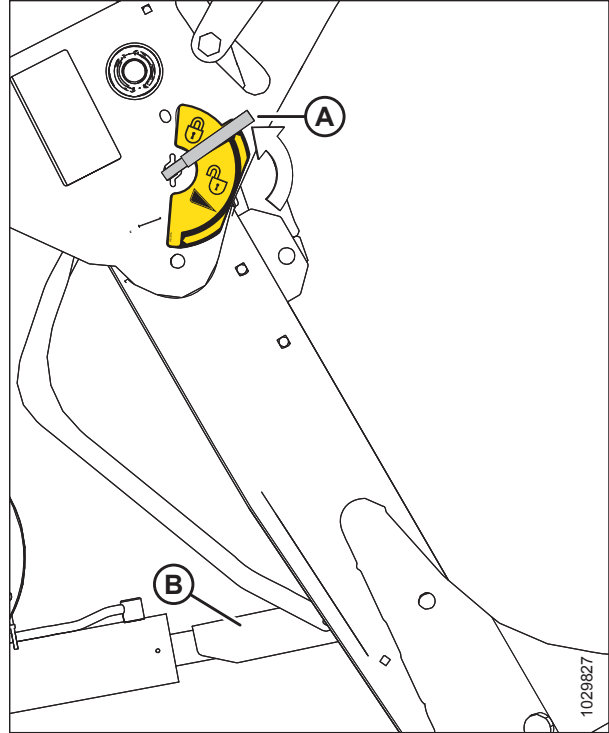

Figure 4.274: Safety Prop

5. Remove hairpin (B) from clevis pin (A) and remove pin from left and right header boots (C) on header.

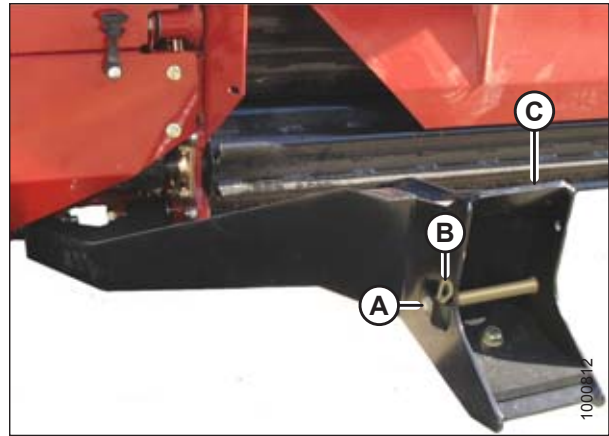

Figure 4.275: Header Boots

OPERATION

6. Remove clevis pin from location (A) to disengage float springs and insert in storage hole (B). Secure with hairpin.

CAUTION

To prevent damage to the lift system when lowering header lift linkages without a header or weight box attached to the windrower, ensure the float engagement pin is installed in storage position (B) and NOT in engaged position (A).

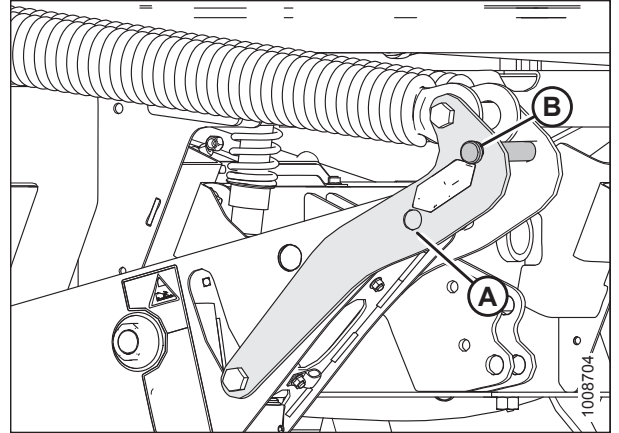

Figure 4.276: Header Float Linkage

7. Turn lever (A) away from header to raise safety prop until lever locks into vertical position. Repeat for opposite cylinder.
8. Start the engine, choose a level area, and lower the header to the ground.
9. Shut down the engine, and remove the key from the ignition.

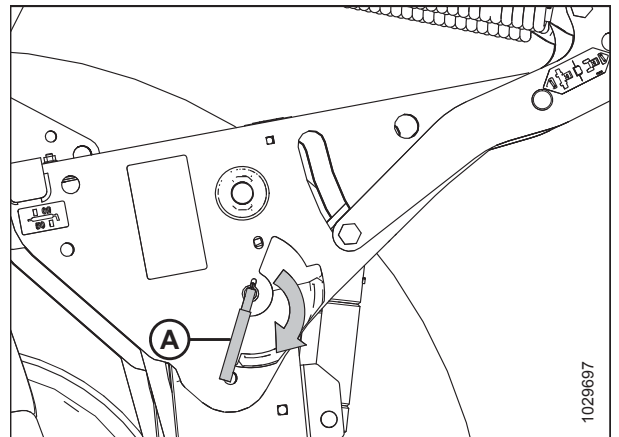

Figure 4.277: Safety Prop

10. Loosen nut (B) and rotate barrel (A) to relieve load on link.

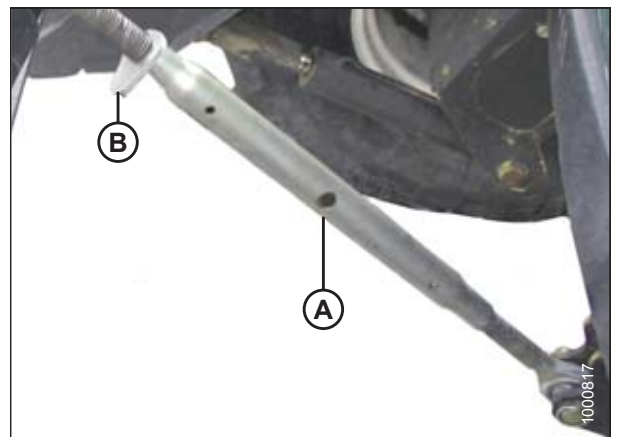

Figure 4.278: Mechanical Center-Link

OPERATION

11. Remove cotter pin on clevis pin (B) and remove pin to disconnect from header. Reinstall clevis pin in header.
12. Tighten nut against barrel (A). A slight tap with a hammer is sufficient.

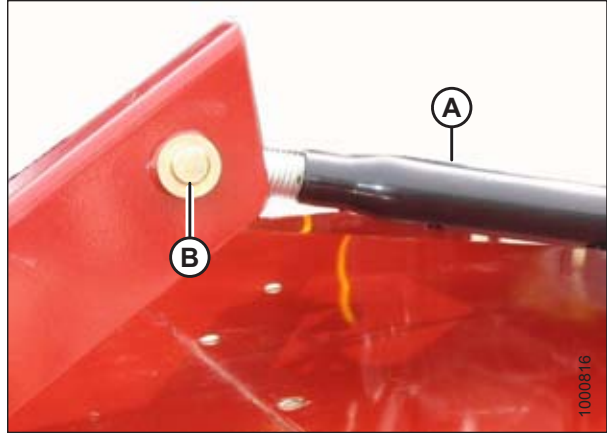

Figure 4.279: Mechanical Center-Link

13. Disconnect header drive hydraulics (A) and electrical harness (B). Refer to the header operator's manual.
14. Start engine and slowly back windrower away from header.

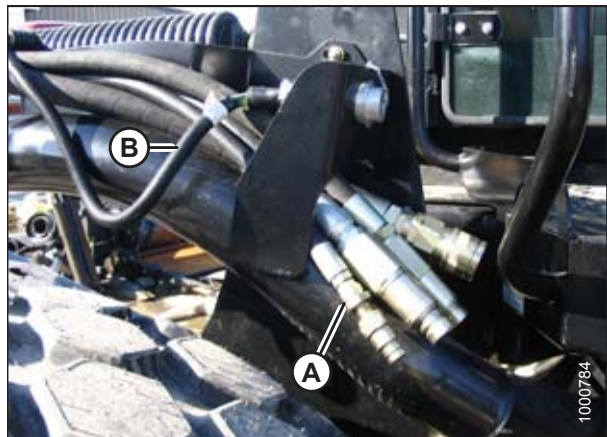

Figure 4.280: Header Drive Hydraulics

15. Stop engine and remove the key.
16. Reinstall the clevis pin (A) through each boot (C) and secure with hairpin (B). Do this to both sides.

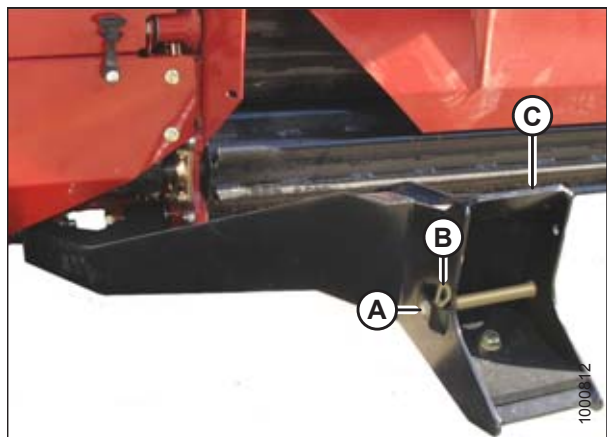

Figure 4.281: Header Boots

4.6 Operating with a D Series or D1 Series Header

The M155 Self-Propelled Windrower is factory-equipped to run a D or D1 Series Draper Header.

If installing a HC10 Hay Conditioner, Reverser kit MD #B4656 is recommended. If necessary, obtain the recommended kit from your MacDon Dealer and install it according to the instructions supplied with the kit.

Refer to the procedures below for the center-link installed on your windrower:

- *Attaching a D Series or D1 Series Draper Header – Hydraulic Center-Link with Optional Self-Alignment, page 219*
- *Attaching a D Series or D1 Series Draper Header – Hydraulic Center-Link without Self-Alignment, page 225*
- *Attaching a D Series or D1 Series Draper Header – Mechanical Center-Link, page 231*

4.6.1 Configuring Hydraulics

The windrower must be fitted with a draper drive basic kit to operate a D or D1 Series Draper Headers.

Windrowers equipped with D or D1 Series hydraulics have four header drive hoses on the left cab-forward side.

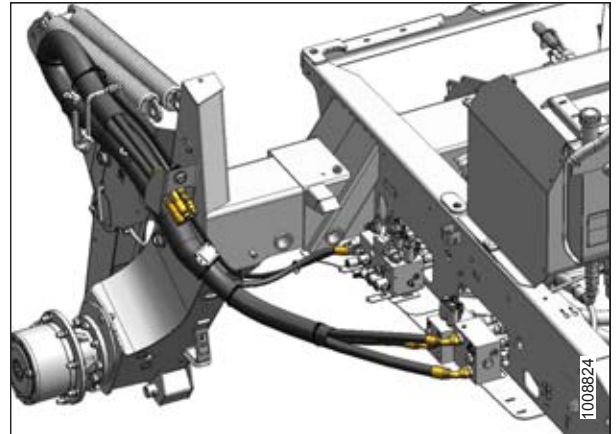

Figure 4.282: Draper Header Hydraulics

There are also up to five reel drive hoses on the right cab-forward side.

If necessary, obtain the following kit from your MacDon Dealer.

- Base kit MD #B5577 (Installation instruction is supplied with the kit.)

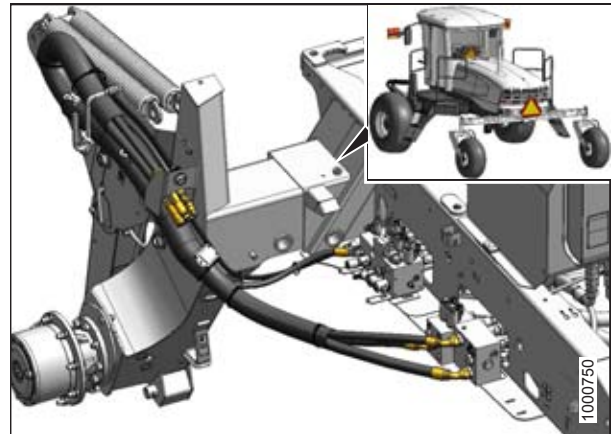

Figure 4.283: Draper Header Drive Hydraulics

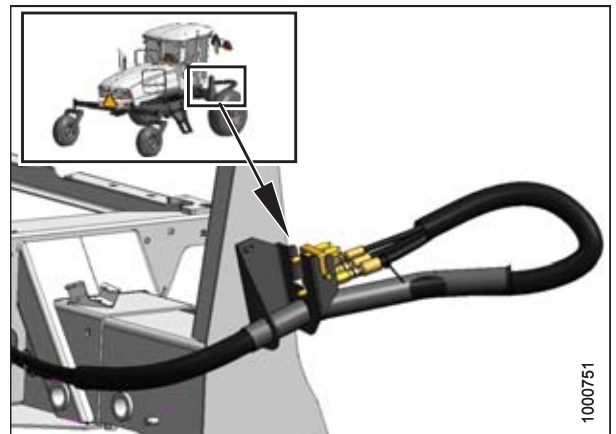

Figure 4.284: Draper Header Reel Hydraulics

4.6.2 Header Position

Refer to *4.4 Operating with a Header, page 196* for procedures for controlling header height, header tilt, and float.

4.6.3 Adjusting the Reel Fore-Aft Position

The reel fore-aft position can be hydraulically adjusted with the optional reel position system and is controlled with multi-function switches on the ground speed lever (GSL).

Press and hold the switch for the desired FORWARD (A) or AFT (B) movement of the reel.



Figure 4.285: Ground Speed Lever

4.6.4 Adjusting the Reel Height

Press and hold the switch for the desired movement of the reel REEL UP (A) or REEL DOWN (B).

IMPORTANT:

Under certain conditions, with the reel raised to full height, the reel tines may contact the cab roof. Exercise care to avoid damage to the machine.

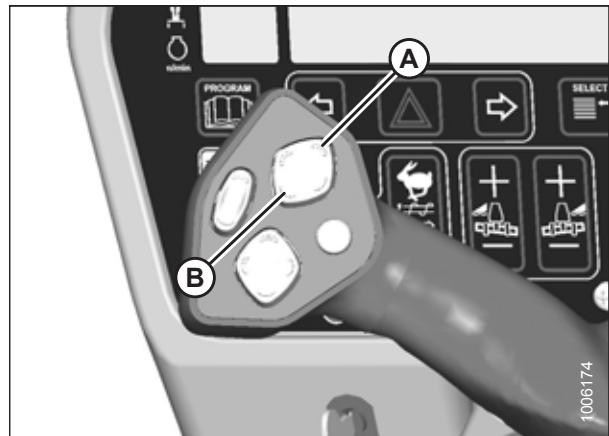

Figure 4.286: Ground Speed Lever (GSL)

4.6.5 Reel Speed

Reel speed is controlled with switches on the ground speed lever (GSL) in the cab. On draper headers, reel speed can run independently, or be set relative to the ground speed of the windrower using the header index feature. Refer to your header's operator manual for specific windrowing guidelines and recommended speeds.

Setting Reel to Ground Speed

Setting the speed of the reel relative to ground speed (using the header index function) allows you to run the engine at lower rpm while maintaining the desired ground and reel speed. Reducing engine speed saves fuel and reduces noise in the cab.

Setting the reel to ground speed requires setting the minimum reel speed and the reel index.

Figure 4.287: Operator Console



CAUTION

Check to be sure all bystanders have cleared the area.

1. Set the minimum reel speed as follows:

IMPORTANT:

Set the minimum reel speed while stationary with the ground speed lever (GSL) in the N-DETENT position.

- a. Engage header.
- b. Set HEADER INDEX switch (B) to **ON**.
- c. Press the DISPLAY SELECTOR button (E) on the GSL to display **##.## MIN REEL** at location (A) or press the FAST (C) or SLOW (D) switch.

The displayed value (##.##) = rpm or mph or km/h²³

23. Depending on CDM programming.

OPERATION

d. Press FAST (C) or SLOW (D) until the desired minimum reel speed is achieved.

2. Set the reel index as follows:

IMPORTANT:

Reel index can only be adjusted while operating at a ground speed faster than minimum reel speed plus header index value.

- a. Set HEADER INDEX switch (B) to **ON**.
- b. Press the DISPLAY SELECTOR button (E) on the GSL to display **##.## #.# REEL IND**²⁴ or press FAST (C) or SLOW (D) switch.
 - The displayed value (**##.##**) = reel speed (rpm or mph or km/h²³)
 - The displayed value (**#.#**) = reel index value
- c. Press FAST (C) or SLOW (D) until the desired reel index is achieved.

NOTE:

The reel will continue operating at the minimum reel speed setting when the ground speed drops below the set value. The cab display module (CDM) display (A) will flash **##.## MIN REEL** (RPM or MPH or KPH) prompting you to change the minimum set-point or increase your ground speed if the total of the ground speed, plus the index value is **LESS THAN** the minimum reel speed set-point.

Examples:

- Windrower is operating at 13 km/h (8 mph) with header index ON and set at -1.0.
Display shows **7.0 -1.0 REEL IND** where **7.0** (8.0-1.0) is the reel speed in mph and **-1.0** is the HEADER INDEX setting.
- Windrower speed drops to 12 km/h (7.5 mph) at same header index setting.
Display shows **6.5 -1.0 REEL IND** where **6.5** (7.5-1.0) is the reel speed in mph and **-1.0** is the HEADER INDEX setting.
- Windrower is operating at 13 km/h (8 mph) with header index ON and set at 2.0.
Display shows: **10.0 2.0 REEL IND** where **10.0** (8+2.0) is the reel speed in mph and **2.0** is the HEADER INDEX setting.

24. REEL IND will only be displayed when operating at a ground speed faster than minimum reel speed plus header index value.

Setting the Reel Only Speed

Figure 4.288: Operator Console



A - Display
D - Reel Slow

B - Header Index
E - Display Selector

C - Reel Fast

CAUTION

Check to be sure all bystanders have cleared the area.

Set the speed of the reel independently of ground speed as follows while operating the windrower:

NOTE:

This procedure is similar to changing the draper speed using the draper speed control switch while in motion. Refer to [Setting Draper Speed Independent of Ground Speed, page 298](#). These changes become the new set-points.

1. Set HEADER INDEX (B) to **OFF**.
2. Press REEL FAST (C) or REEL SLOW (D) on the ground speed lever (GSL) until display (A) shows **##.## REEL MPH** with desired reel speed.

The displayed value (##.##) = reel speed (rpm or mph or km/h²⁵)

25. Depending on cab display module (CDM) programming.

4.6.6 Draper Speed

Draper speed affects the orientation of stalks in the windrow. For information on draper speed guidelines and windrow types, refer to your header operator's manual. The draper speed can be set to run independently, or relative to the ground speed of the windrower with the header index function.

Setting Draper to Ground Speed

Setting the speed of the draper relative to ground speed (using the header index function) allows you to run the engine at lower rpm while maintaining the desired ground and draper speed. Reducing engine speed saves fuel and reduces noise in the cab.

Setting draper to ground speed requires setting both the minimum draper speed and the draper index.

Refer to the following:

- [Setting Minimum Draper Speed, page 295](#)
- [Setting Draper Index, page 296](#)

Setting Minimum Draper Speed

Figure 4.289: Operator Console



CAUTION

Check to be sure all bystanders have cleared the area.

Set draper minimum speed as follows:

IMPORTANT:

Set the minimum draper speed while stationary with the ground speed lever (GSL) in the N-DETENT position.

1. Engage header.
2. Set HEADER INDEX (B) switch to **ON**.
3. Press DISPLAY SELECTOR button (E) until display (A) shows **##.## DRAPER MIN**.
The displayed value (##.##) = draper speed (mph or km/h²⁶).
4. Use the FAST (C) and SLOW (D) buttons to set the desired minimum draper speed.

26. Depending on cab display module (CDM) programming.

Setting Draper Index

Figure 4.290: Operator Console



CAUTION

Check to be sure all bystanders have cleared the area.

Set draper index as follows:

IMPORTANT:

Draper Index can only be adjusted while operating at a ground speed faster than minimum draper speed plus header index value.

1. Engage header.
2. Set HEADER INDEX switch (B) to **ON**.
3. Press DISPLAY SELECTOR (E) on the ground speed lever (GSL) to display **DRAPER INDX²⁷** at (A) on the cab display module (CDM).

27. DRAPER INDX will only be displayed when operating at a ground speed faster than minimum draper speed plus the header index value.

OPERATION

4. Press DRAPER FAST (C) or SLOW (D) on the CDM until display (A) shows **##.## ##.# DRAP IND** with the desired index value.
 - The displayed value (##.##) = draper speed (mph or km/h²⁸)
 - The displayed value (##.#) = the index value

Examples:

- Windrower is operating at 13 km/h (8 mph) with header index ON and set at 1.5.
Display shows: **9.5 1.5 DRAP INDX** where **9.5** (8 + 1.5) is the draper speed in mph and **1.5** is the header index setting.
- Windrower speed drops to 12 km/h (7.5 mph) at same header index setting.
Display shows: **9.0 1.5 DRAP INDX** where **9.0** (7.5 + 1.5) is the draper speed in mph and **1.5** is the header index setting.
- Windrower is operating at 13 km/h (8 mph) with header index ON and set at 0.9.
Display shows: **8.9 0.9 DRAP INDX** where **8.9** (8 + 0.9) is the draper speed in mph and **0.9** is the header index setting.

28. Depending on CDM programming.

OPERATION

Setting Draper Speed Independent of Ground Speed

Figure 4.291: Operator Console

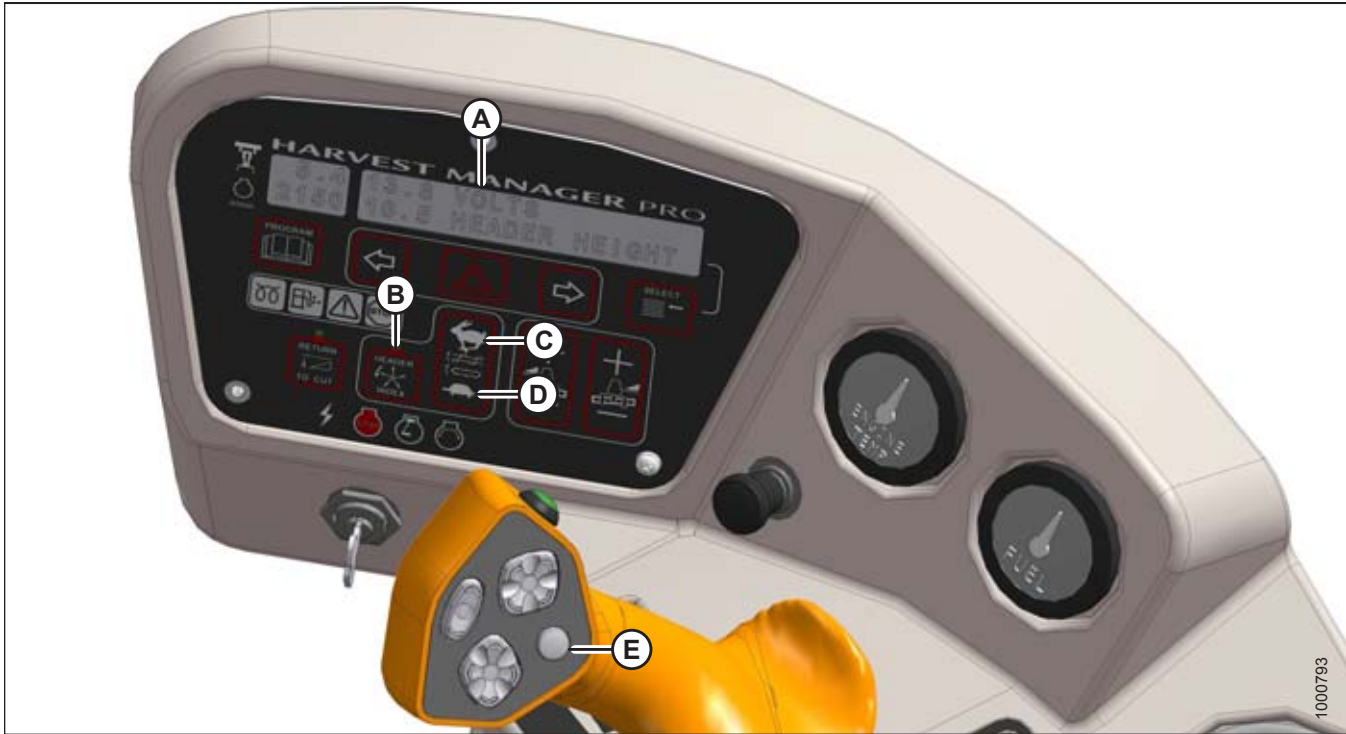

Set the speed of the draper independent of ground speed as follows:

NOTE:

This procedure can also be used to change the draper speed while in motion.

CAUTION

Check to be sure all bystanders have cleared the area.

1. Engage header.
2. Set HEADER INDEX switch (B) to **OFF**.
3. Press DISPLAY SELECTOR button (E) to show **### DRAPER SPEED** on the cab display module (CDM) (A).
Displayed value (###) = draper speed (mph or km/h²⁹).
4. Press FAST (C) or SLOW (D) on the CDM until desired draper speed is displayed at location (A).

29. Depending on CDM programming.

4.6.7 Knife Speeds

The ideal knife speed should achieve a clean cut. Crop types and conditions usually influence the knife and ground speeds.

Table 4.2 Knife Speed Table

Header Description		Knife Speed			
Type	Size	Minimum		Maximum	
		rpm ³⁰	spm ³¹	rpm ³⁰	spm ³¹
Draper with double knife	4.6 m (15 ft.)	750	1500	950	1900
Draper with double knife	6.1 and 7.6 m (20 and 25 ft.)	700	1400	850	1700
Draper with double knife	9.1 m (30 ft.)	600	1200	800	1600
Draper with double knife	10.6 m (35 ft.)	600	1200	700	1400
Draper with double knife	12.2 m (40 ft.)	550	1100	700	1400
Draper with single knife	6.1 and 7.6 m (20 and 25 ft.)	600	1200	750	1500
Draper with single knife	9.1 m (30 ft.)	600	1200	700	1400
Draper with single knife	10.6 m (35 ft.)	550	1100	700	1400
Draper with single knife	12.2 m (40 ft.)	525	1050	600	1200

When the header is first attached to the windrower, the windrower control module (WCM) receives a code from the header that determines the knife speed range and the minimum speed.

The desired speed can be programmed on the cab display module (CDM) and stored in the WCM memory so the knife will operate at the original set point after the header is detached and reattached to the windrower.

If no header code is detected, the CDM displays NO HEADER and the knife speed reverts to the operator’s selection from a range of 800–1000 strokes per minute.

Refer to Header Settings in the header operator’s manual for the suggested knife speed for a variety of crops and conditions.

NOTE:

Knife speed cannot be programmed outside the range specified for each header.

NOTE:

Knife speed can be adjusted without shutting down the machine; however, the windrower should be stopped before adjusting CDM settings.

To adjust the knife speed, refer to *Setting the Header Knife Speed, page 95*.

30. Revolutions per minute is the speed of knife drive box pulley.

31. Strokes per minute of knife (rpm x 2).

4.6.8 Deck Shift Control

When connected to a draper header with the deck shift option, hydraulic deck shift control allows you to select the deck position and draper rotation of the header from the operator's station. Deck shift allows you to select crop delivery from the left side, center, or right side of the header.

Deck Shift

CAUTION

Check to be sure all bystanders have cleared the area.

Shift decks as follows:

1. Engage header by pushing down on the yellow HEADER DRIVE button (A) while pulling up on the black ring (B) at the base of the switch.

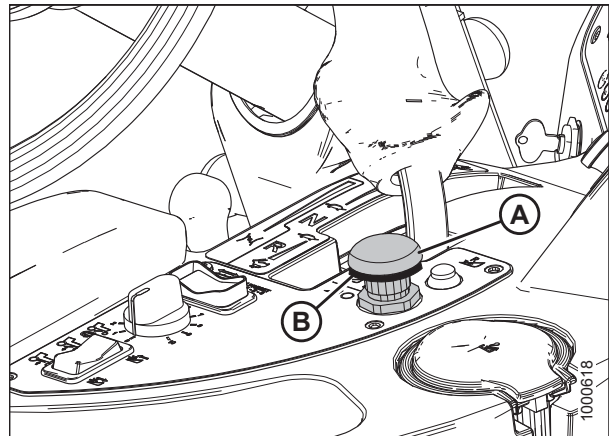

Figure 4.292: Header Drive Button

2. Push switch (A) to desired delivery position. Deck(s) will move and direction of drapers will change accordingly.
3. Operate windrower.

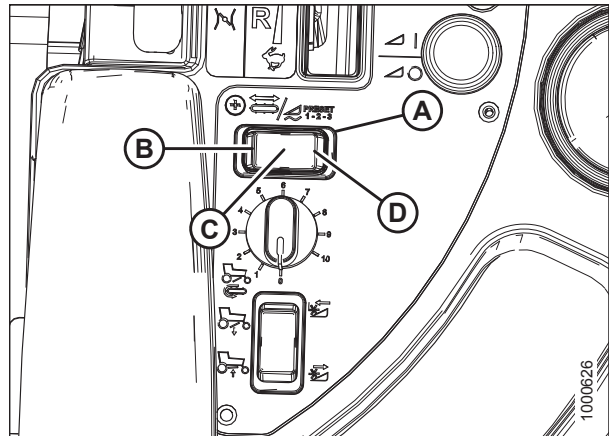

Figure 4.293: Deck Shift Switch

A - Deck Shift Switch
 B - Left-Side Delivery
 C - Center Delivery
 D - Right-Side Delivery

OPERATION

Setting Float Options with Deck Shift

For draper headers equipped with the deck shift option, the header float can be set for each deck position. Float is maintained when the decks are shifted.

CAUTION

Check to be sure all bystanders have cleared the area.

Program the float as follows:

1. Engage header.
2. Using HEADER TILT SWITCHES (A) and (B) on the ground speed lever (GSL), set center-link to mid-range position (05.0 on display [C]).

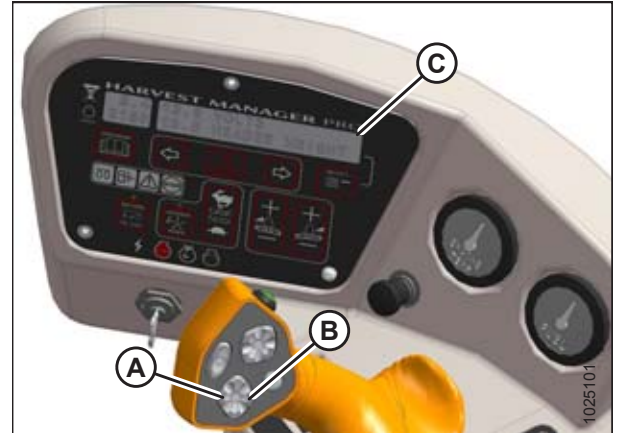

Figure 4.294: Operator Console

3. Select a deck position with DECK SHIFT switch (A) from one of the following delivery options:
 - B - Left-side delivery
 - C - Center delivery
 - D - Right-side delivery

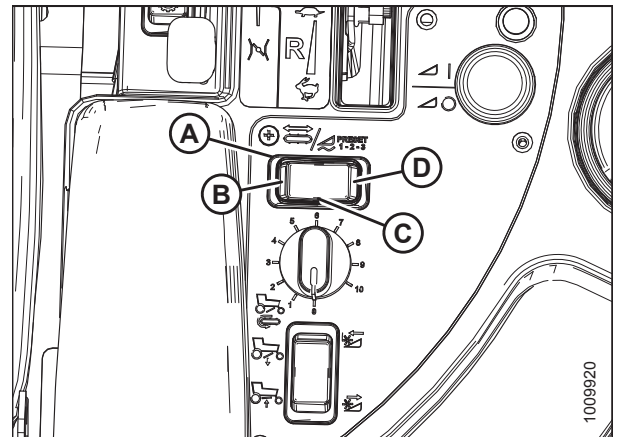

Figure 4.295: Deck Shift Switch

OPERATION

- Using HEADER DOWN switch (A) on the GSL, lower header fully with lift cylinders fully retracted.
- Using LEFT FLOAT SWITCH (B), push + to increase float or – to decrease float on left side of header. Display (D) will indicate selected float value for left side, for example (8.0 L FLOAT R ###.#).
- Repeat for right side float with RIGHT switch (C). Display (D) will indicate float value for both sides, for example (8.0 L FLOAT R 3.0).

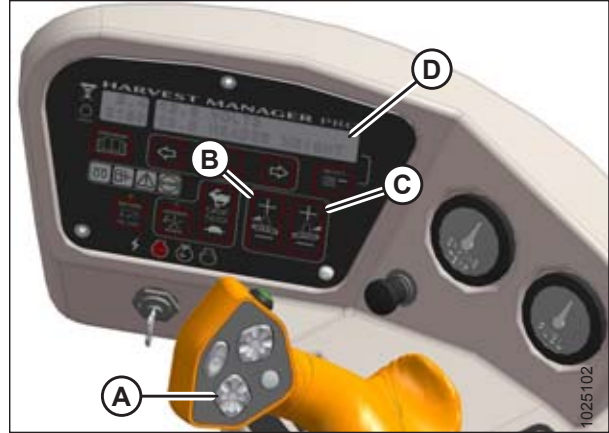

Figure 4.296: Operator Console

- Select a second deck position with the DECK SHIFT switch (A).
- Repeat Step 5, page 302 and Step 6, page 302 to set the float for the second deck position.
- Select a third deck position with the DECK SHIFT switch (A).
- Repeat Step 5, page 302 and Step 6, page 302 to set the float for the third deck position.

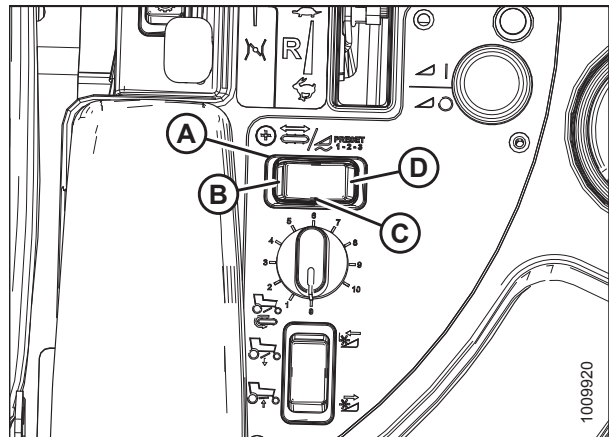

Figure 4.297: Deck Shift Switch

A - Deck Shift Switch
B - Left-Side Delivery
C - Center Delivery
D - Right-Side Delivery

4.7 Operating with an A Series Header

The M155 is factory-equipped to run an A Series Auger Header.

4.7.1 Auger Speed

Auger Speed on A30D Headers

On A30D Auger Headers, the auger speed is fixed to the knife speed. The auger speed is **NOT** monitored and cannot be displayed.

Setting the Auger Speed on A40D Headers

Figure 4.298: Operator Console



CAUTION

Check to be sure all bystanders have cleared the area.

To set the auger speed, follow these steps:

1. Engage header.
2. Set the HEADER INDEX switch (B) to **OFF**.
3. Set the REEL SPEED to the minimum setting. For instructions, refer to [Reel and Disc Speed Switches, page 71](#).
4. Press DISPLAY SELECTOR switch (E) on the ground speed lever (GSL) or press FAST (C) or SLOW (D) on the cab display module (CDM) until **### AUGER SPEED** is displayed at location (A).

The displayed value (###) = auger speed setting.

NOTE:

Changes to reel speed will affect the auger speed directly. However, when adjusting reel speed, the auger speed value displayed on the CDM will not change.

OPERATION

5. Press FAST (C) or SLOW (D) on the CDM until the desired auger speed is achieved.

4.7.2 Reel Speed

Refer to your header operator's manual for recommended reel speed settings for your particular crop.

Reel Speed on A30D Headers

The reel is driven by the auger and both are dependent on the main header drive speed. The auger and reel speed can only be changed by installing a different size auger drive sprocket, or by varying the windrower engine rpm. A30D headers do **NOT** have a reel speed sensor, therefore no reel/auger speed information is displayed on the cab display module.

Reel Speed on A40D Headers

The A40D Auger Header features a hydraulic direct drive reel with an operating speed range of 15–85 rpm. Reel speed is controlled by the cab display module (CDM) and the ground speed lever (GSL) in the operator's station.

The reel drive motor and the auger drive motor are connected in series but a separate line to the auger allows the reel speed to change independently from the auger speed. Switches on the GSL are used to adjust the reel speed which is displayed on the CDM display. The reel speed can be set by three methods:

- Reel Only (only reel speed changes)
- Reel On-the-Go (reel and auger speeds change)
- Reel to Ground (indexed)

NOTE:

Adjusting the reel speed will result in a change to auger speed unless the auger speed has been preset.

Adjusting Reel Only Speed

The A40D reel drive is hydraulically driven. Adjusting reel speed also changes auger speed, unless the auger speed is initially set at a predetermined value. The following procedure sets the auger speed so that subsequent reel speed adjustments will only affect the reel.

Figure 4.299: Operator Console

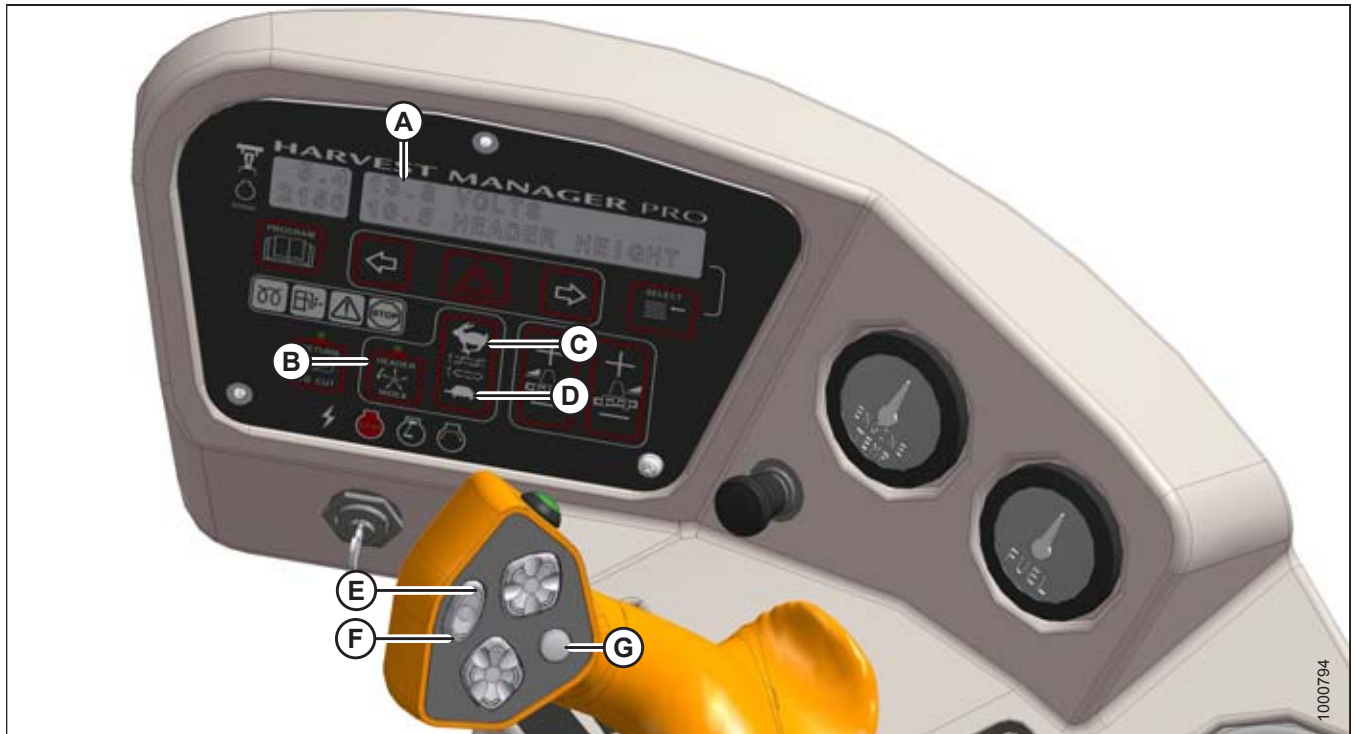

- | | | |
|----------------------|------------------|----------------|
| A - Display | B - Header Index | C - Auger Fast |
| D - Auger Slow | E - Fast | F - Slow |
| G - Display Selector | | |

To prevent overspeeding the auger, initially set the speed of the reel and auger as follows:

NOTE:

Subsequent adjustments to reel speed do **NOT** affect auger speed.

1. Engage header.
2. Set HEADER INDEX SWITCH (B) to **OFF**.
3. On ground speed lever (GSL) press REEL SLOW switch (F) until a beep is heard.
4. Display (A) shows **###.## REEL RPM**.
5. On cab display module (CDM) press AUGER SLOW (D) or FAST (C) switch to set desired auger speed.
6. Display (A) shows **###.## AUGER SPEED**.
7. On the GSL, press REEL SLOW (F) or FAST (E) switch to set desired reel speed.
8. Display (A) shows **###.## REEL RPM**.

NOTE:

The auger speed will **NOT** change if the reel speed is adjusted.

OPERATION

Adjusting Reel Speed: Windrower in Motion

Figure 4.300: Operator Console

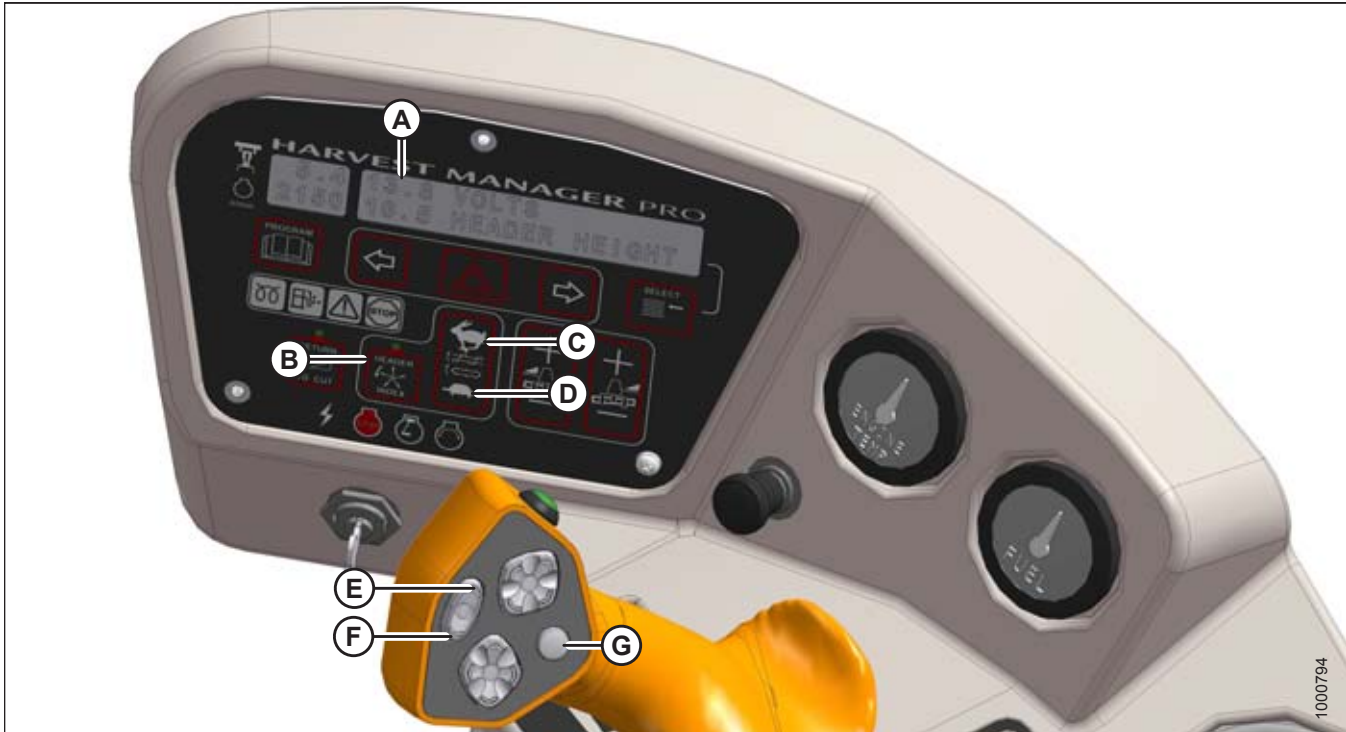

A - Display
E - Reel Fast

B - Header Index
F - Reel Slow

C - Auger Fast
G - Display Selector

D - Auger Slow

The reel speed adjustment range is from 15 to 85 rpm. Adjust the reel speed while the machine is in operation as follows:

1. Set HEADER INDEX switch (B) to **OFF**.
2. Press REEL SLOW (F) or REEL FAST (E) on the ground speed lever (GSL) until display (A) shows **###.## REEL RPM** with desired reel speed.

The displayed value (###.##) = reel speed (rpm or mph or km/h³²).

NOTE:

Adjusting reel speed will alter auger speed unless the auger speed has been preset.

32. Depending on CDM programming.

OPERATION

Setting Reel to Ground Speed

Setting the speed of the reel relative to ground speed (using the header index function) automatically adjusts the reel speed with changes to ground speed. Benefits may include improved crop flow and reduced operator fatigue.

Setting the reel to ground speed requires setting the minimum reel speed and the reel index.

Figure 4.301: Operator Console



CAUTION

Check to be sure all bystanders have cleared the area.

1. Set the minimum reel speed as follows:

IMPORTANT:

Set the minimum reel speed while stationary with the ground speed lever (GSL) in the N-DETENT position.

- a. Engage header.
- b. Set HEADER INDEX switch (B) to **ON**.
- c. Press the DISPLAY SELECTOR button (E) on the GSL to display **###.## MIN REEL** at location (A) or press the FAST (C) or SLOW (D) switch.

The displayed value (###.##) = reel speed (rpm or mph or km/h³³).

- d. Press FAST (C) or SLOW (D) until the desired minimum reel speed is achieved.

33. Depending on CDM programming.

OPERATION

- Set the reel index as follows:

IMPORTANT:

Reel index can only be adjusted while operating at a ground speed faster than minimum reel speed plus header index value.

Figure 4.302: Operator Console



- Set the HEADER INDEX switch (B) to **ON**.
- Press the DISPLAY SELECTOR button (E) on the GSL to display **##.## ##.# REEL IND³⁴** or press the FAST (C) or SLOW (D) switch.
 - The displayed value (**##.##**) = reel speed (mph or km/h or rpm³³)
 - The displayed value (**##.#**) = reel index value
- Press FAST (C) or SLOW (D) until the desired reel index value is achieved.

NOTE:

The reel will continue operating at the minimum reel speed setting when ground speed drops below the set value.

The cab display module (CDM) display (A) will flash **##.## MIN REEL (RPM or MPH or KPH³³)** prompting you to change the minimum set-point or increase ground speed if the total of ground speed, plus the index value is **LESS THAN** the minimum reel speed set-point.

34. REEL IND will only be displayed when operating at a ground speed faster than minimum reel speed plus header index value.

OPERATION

Examples:

- Windrower is operating at 8 mph with HEADER INDEX ON, and set at -1.0.
Display shows: **7.0 -1.0 REEL IND** where **7.0** (8.0-1.0) is the reel speed in mph and **-1.0** is the header index setting.
- Windrower speed drops to 7.5 mph at same HEADER INDEX setting.
Display shows: **6.5 -1.0 REEL IND** where **6.5** (7.5-1.0) is the reel speed in mph and **-1.0** is the header index setting.
- Windrower is operating at 8 mph with HEADER INDEX ON, and set at 2.0.
Display shows: **10.0 2.0 REEL IND** where **10.0** (8+2.0) is the reel speed in mph and **2.0** is the header index setting.

4.7.3 Knife Speed

The ideal cutting speed should achieve a clean cut. Crop types and conditions usually influence the knife and ground speeds.

When the header is first attached to the windrower, the windrower control module (WCM) receives a code from the header that determines the knife speed range and the minimum speed. The desired speed can be programmed on the cab display module (CDM) and stored in the WCM memory so the knife will operate at the original set-point after the header is detached and reattached to the windrower. If no header code is detected, the CDM displays NO HEADER and the knife speed reverts to the operator's selection from a range of 800–1000 strokes per minute. Refer to the header operator's manual for the suggested knife speed for a variety of crops and conditions.

NOTE:

The knife speed cannot be programmed outside the range specified for each header.

NOTE:

The knife speed can be adjusted without shutting down the machine; however, the windrower should be stopped before adjusting CDM settings.

To adjust the knife speed, refer to [Setting the Header Knife Speed, page 95](#).

4.8 Operating with an R Series or R1 Series Header

The R80 and R85 4.0 m (13 ft.) headers are shipped without the motor and hoses installed. The installation of a separate motor and hose bundle is necessary.

If required, obtain kit (MD #B5510) from your MacDon Dealer, and install it according to the instructions supplied with the kit.

NOTE:

Hydraulic Coupler kit (MD #B5497) is also available for quick attachment and removal of multiple header types.

R1 Series headers come from the Dealer with the required completion package (MD #B6272).

A Disc Drive kit (MD #B4657) is also required in order for the windrower to operate the header.

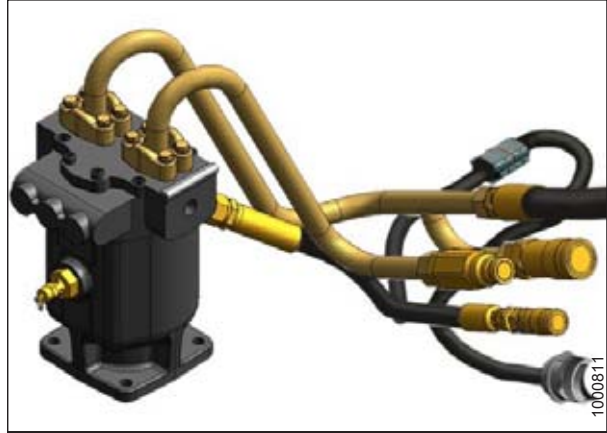

Figure 4.303: Kit MD #B5510

4.8.1 Disc Speed

The ideal disc speed should achieve a clean cut. Crop types and conditions affect disc and ground speeds. Refer to the header operator's manual for the suggested disc speed for a variety of crops and conditions.

Setting Disc Speed

Figure 4.304: Operator Console



A - Display
D - Slow

B - Header Index
E - Display Selector

C - Fast

CAUTION

Check to be sure all bystanders have cleared the area.

Follow these steps to set the disc speed:

1. Engage header.
2. Set HEADER INDEX switch (B) to **OFF**.
3. Press FAST (C) or SLOW (D) on ground speed lever (GSL) until display (A) shows **#### DISC RPM** with desired disc speed.

Displayed value (####) = disc speed (rpm).

Chapter 5: Maintenance and Servicing

The following section will guide you through some of the windrower's basic maintenance and service requirements. More detailed maintenance, service, and parts information is available from your MacDon Dealer.

5.1 Preparation for Servicing



WARNING

To avoid personal injury, before servicing adapter/header or opening drive covers:

- Fully lower the header. If necessary to service in the raised position, always engage lift safety props.
- Disengage drives.
- Stop engine, and remove key.
- Wait for all moving parts to stop.

5.2 Engine Compartment Hood

The engine compartment hood has two open positions. The lowest is for general maintenance such as checking and adding fluid, servicing the cooling box, etc. The highest position provides full access to the engine compartment.

5.2.1 Opening Hood – Lower Position

WARNING

To avoid bodily injury or death from unexpected startup of the machine, always stop the engine and remove the key from the ignition before leaving the operator's seat for any reason.

1. Shut down the engine, and remove the key from the ignition.
2. Locate latch (A) behind the grill and lift to release the hood.
3. Raise hood until strap (B), which should be looped under hooks (C) and (D), stops at approximately a 40° angle.
4. Remove strap (B) from hook (C) and allow the hood to rise slightly farther.

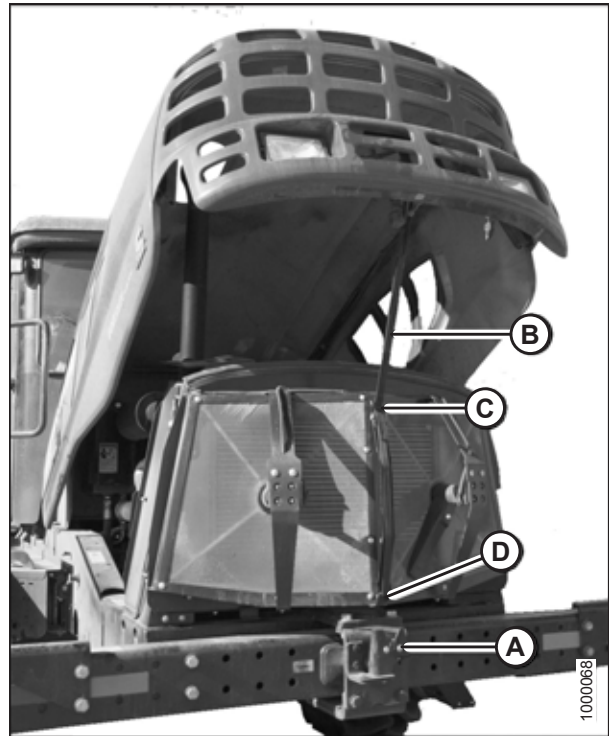

Figure 5.1: Hood Open (Lower Position)

5.2.2 Closing Hood – Lower Position

1. Grasp the strap at location (B) and loop under upper hook (C).

IMPORTANT:

Failure to hook strap may result in it becoming entangled with the screen cleaners or the latch.

2. Pull down on strap, grasp the hood when within reach, and lower until hood engages latch (A).

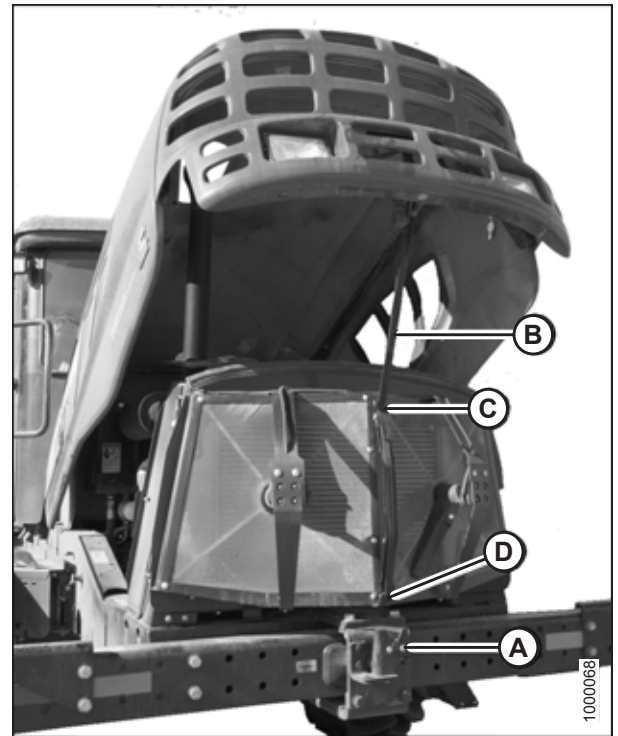

Figure 5.2: Hood Open (Lower Position)

5.2.3 Opening Hood – Highest Position

WARNING

To avoid bodily injury or death from unexpected startup of the machine, always stop the engine and remove the key from the ignition before leaving the operator's seat for any reason.

1. Shut down the engine, and remove the key from the ignition.
2. Locate latch (A) behind the grill and lift to release the hood.
3. Raise hood until strap (B), which should be looped under hooks (C) and (D), stops at approximately a 40° angle.
4. Remove strap (B) from hook (C) and allow hood to rise slightly farther.
5. Remove the strap from hook (D) and allow the hood to rise fully to approximately a 65° angle.

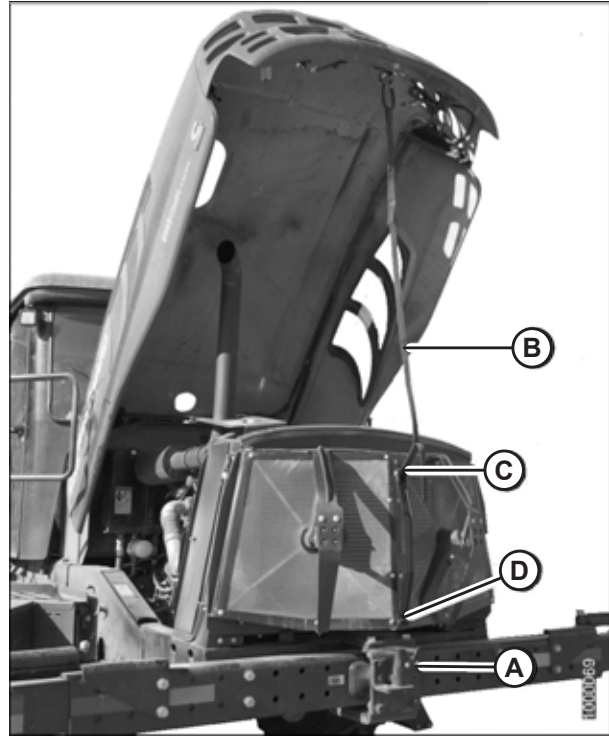

Figure 5.3: Hood Open (Highest Position)

5.2.4 Closing Hood – Highest Position

1. Pull down on strap (B) and loop under lower hook (D).
2. Grasp strap (B) and loop under upper hook (C).

IMPORTANT:

Failure to hook strap may result in it becoming entangled with the screen cleaners or the latch.

3. Pull down on strap (B), grasp the hood when within reach, and lower until hood engages latch (A).

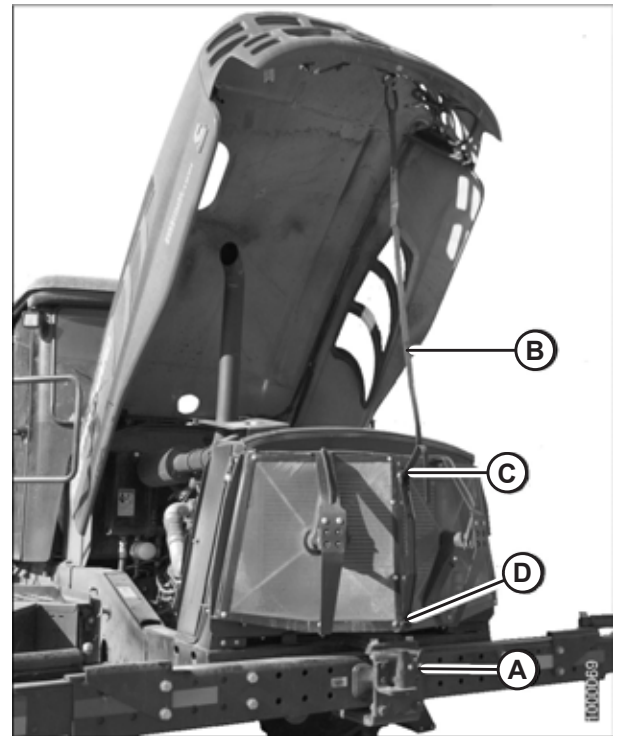

Figure 5.4: Hood Open (Highest Position)

5.3 Maintenance Platforms

Swing-away platforms and stairs are provided on both sides of the windrower for access to the operator's station and engine bay. The platforms can be swung away from the windrower to allow access to the hydraulics plumbing or battery.

The maintenance platforms have three positions:

- Closed position
- Open standard position
- Open major servicing position

5.3.1 Opening Platforms – Standard Position

CAUTION

Do NOT stand on an unlocked platform. It is unstable and may cause you to fall.

This procedure describes how to open the cab-forward left platform (A). The same procedure is used for the right platform (B).

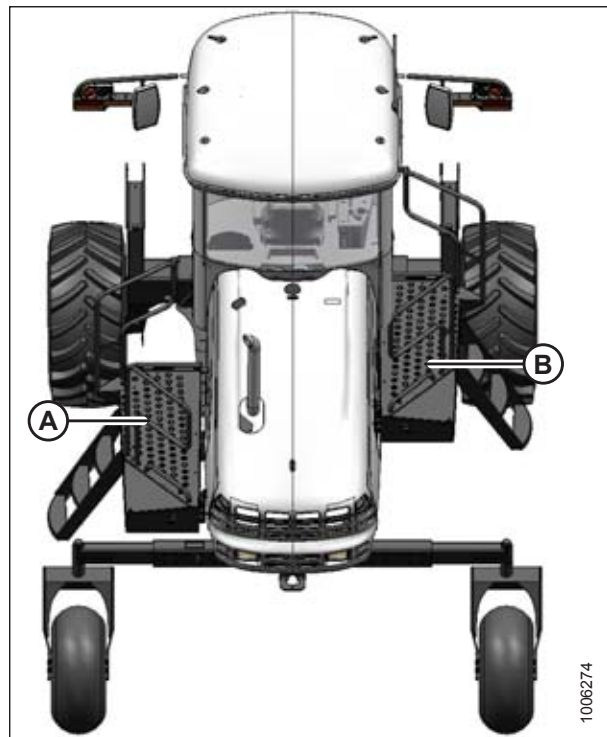

Figure 5.5: Platforms

MAINTENANCE AND SERVICING

1. Push latch (A) and pull platform (B) toward walking beam until it stops and latch engages in open position.

NOTE:

Ensure the platform is latched before using.

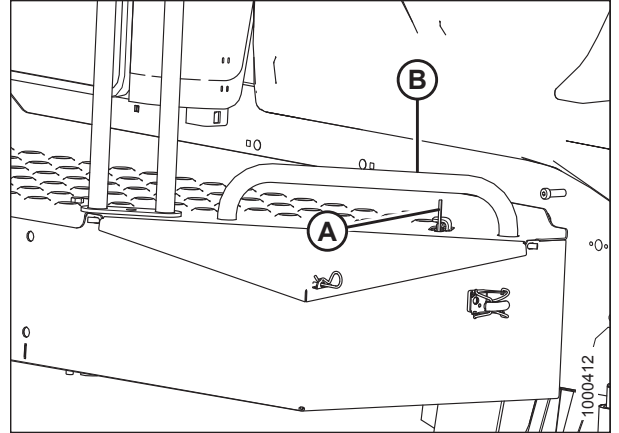

Figure 5.6: Platform Latch

5.3.2 Closing Platforms – Standard Position

CAUTION

Do NOT stand on an unlocked platform. It is unstable and may cause you to fall.

This procedure describes how to close the cab-forward left platform (A). The same procedure is used for the right platform (B).

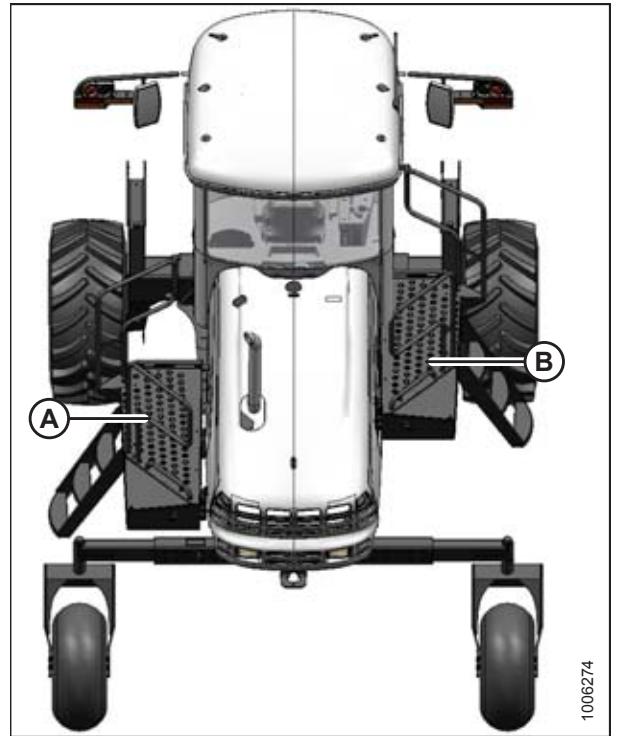

Figure 5.7: Platforms

MAINTENANCE AND SERVICING

1. If platform is latched in the open position, push latch (A) to unlock it.
2. Grasp handle (B) on platform and push forward until it stops and latch (A) engages.

NOTE:

Ensure the platform is latched properly before using.

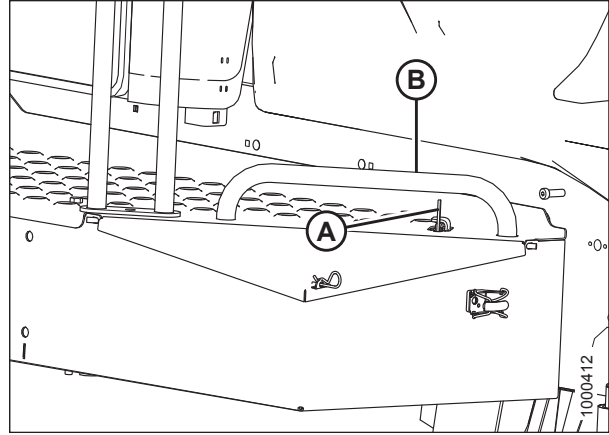

Figure 5.8: Platform Latch

5.3.3 Opening Platforms – Major Service Position

To improve access to the hydraulics plumbing or battery, the platforms can be swung away from the windrower.

CAUTION

Do NOT stand on an unlocked platform. It is unstable and may cause you to fall.

This procedure describes how to open the cab-forward left platform (A). The same procedure is used for the right platform (B).

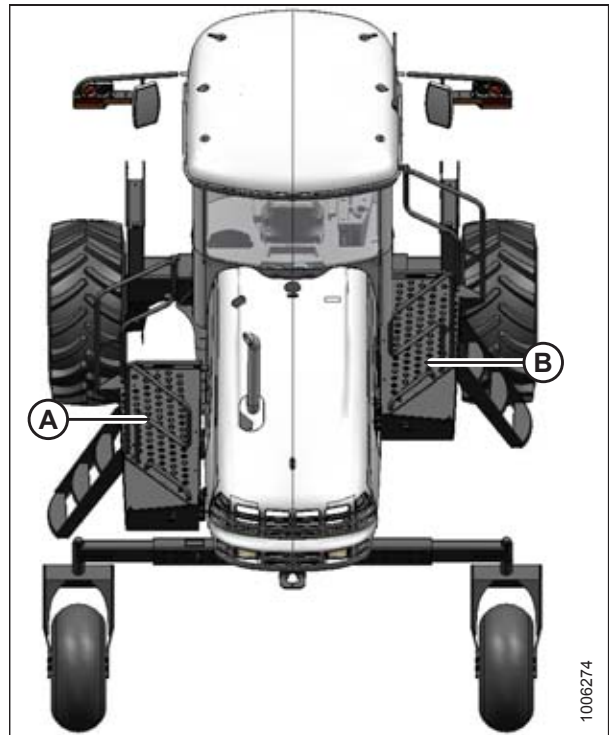

Figure 5.9: Platforms

1. Open the hood. Refer to [5.2.1 Opening Hood – Lower Position, page 314](#).

IMPORTANT:

Failure to open hood will result in damage to the hood when the platform is moved.

MAINTENANCE AND SERVICING

2. Unlock latch (A) and move platform (B) toward open position. Do **NOT** lock in full aft position.

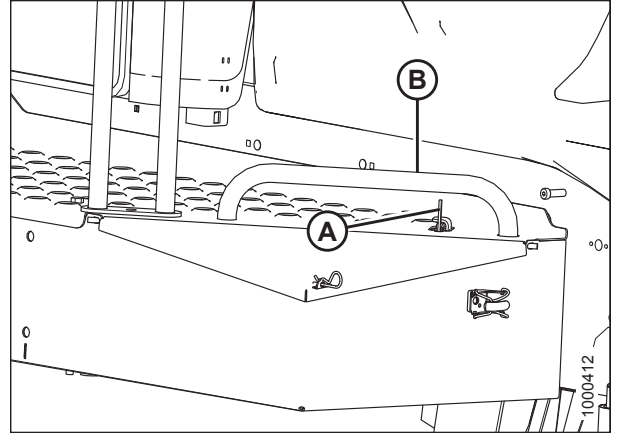

Figure 5.10: Platform Latch

3. Remove the nut and bolt that secure link (A) to the frame. Swing link (A) out of the way.
4. Pull the front (cab-forward) end of platform away from frame while moving it towards the walking beam. The aft corner of platform (B) should project slightly into the engine bay when the opening is optimum.

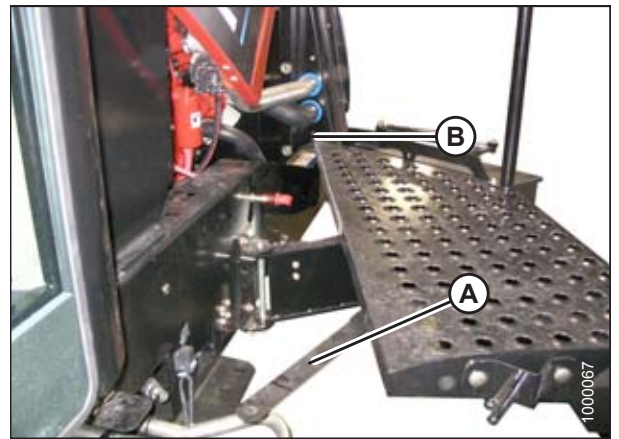

Figure 5.11: Platform

5.3.4 Closing Platforms – Major Service Position

CAUTION

Do NOT stand on an unlocked platform. It is unstable and may cause you to fall.

NOTE:

This procedure is applicable to both platforms. Left side is shown.

1. Swing link (A) all the way forward.
2. Push the front (cab-forward) end (B) of platform towards the frame while moving the platform forward (cab-forward).
3. Position link (A) on bracket and install bolt and nut. Tighten enough so that link can still swivel on bracket.
4. Move platform (B) forward (cab-forward) until it stops and latch (A) engages.
5. Close the hood. Refer to [5.2.2 Closing Hood – Lower Position, page 315](#).

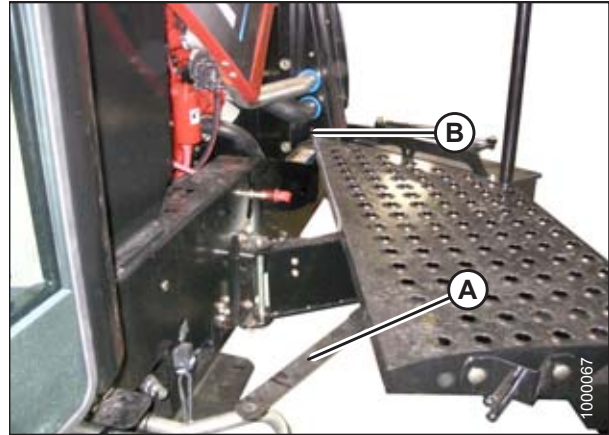

Figure 5.12: Platform

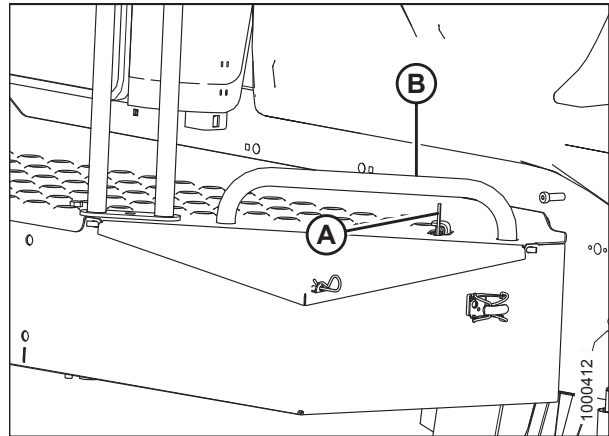

Figure 5.13: Platform Latch

5.4 Windrower Lubrication

WARNING

To avoid personal injury, before servicing windrower or opening drive covers, follow procedures in the SAFETY chapter.

The greasing points are marked on the machine by decals showing a grease gun and grease interval in hours of operation.

Log hours of operation and use the Maintenance Checklist provided to keep a record of scheduled maintenance. Refer to [5.12.1 Maintenance Schedule/Record, page 443](#).

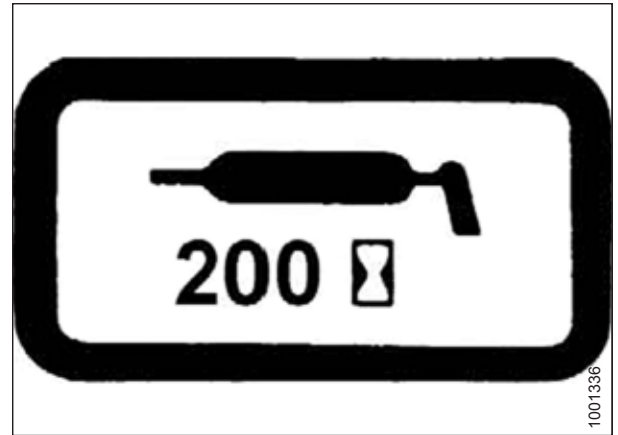

Figure 5.14: Lubrication Interval Decal

5.4.1 Lubricating the Windrower

WARNING

To avoid bodily injury or death from unexpected startup of the machine, always stop the engine and remove the key from the ignition before leaving the operator's seat for any reason.

1. To avoid injecting dirt and grit, wipe grease fitting with a clean cloth before greasing.
2. Inject grease through fitting with grease gun until grease overflows fitting, except where noted. Refer to [8.2.3 Lubricants, Fluids, and System Capacities, page 479](#).
3. Leave excess grease on fitting to keep out dirt.
4. Replace any loose or broken fittings immediately.
5. If fitting will **NOT** take grease, remove and clean thoroughly. Also clean lubricant passageway. Replace fitting if necessary.

5.4.2 Lubrication Points

Figure 5.15: Lubrication Points

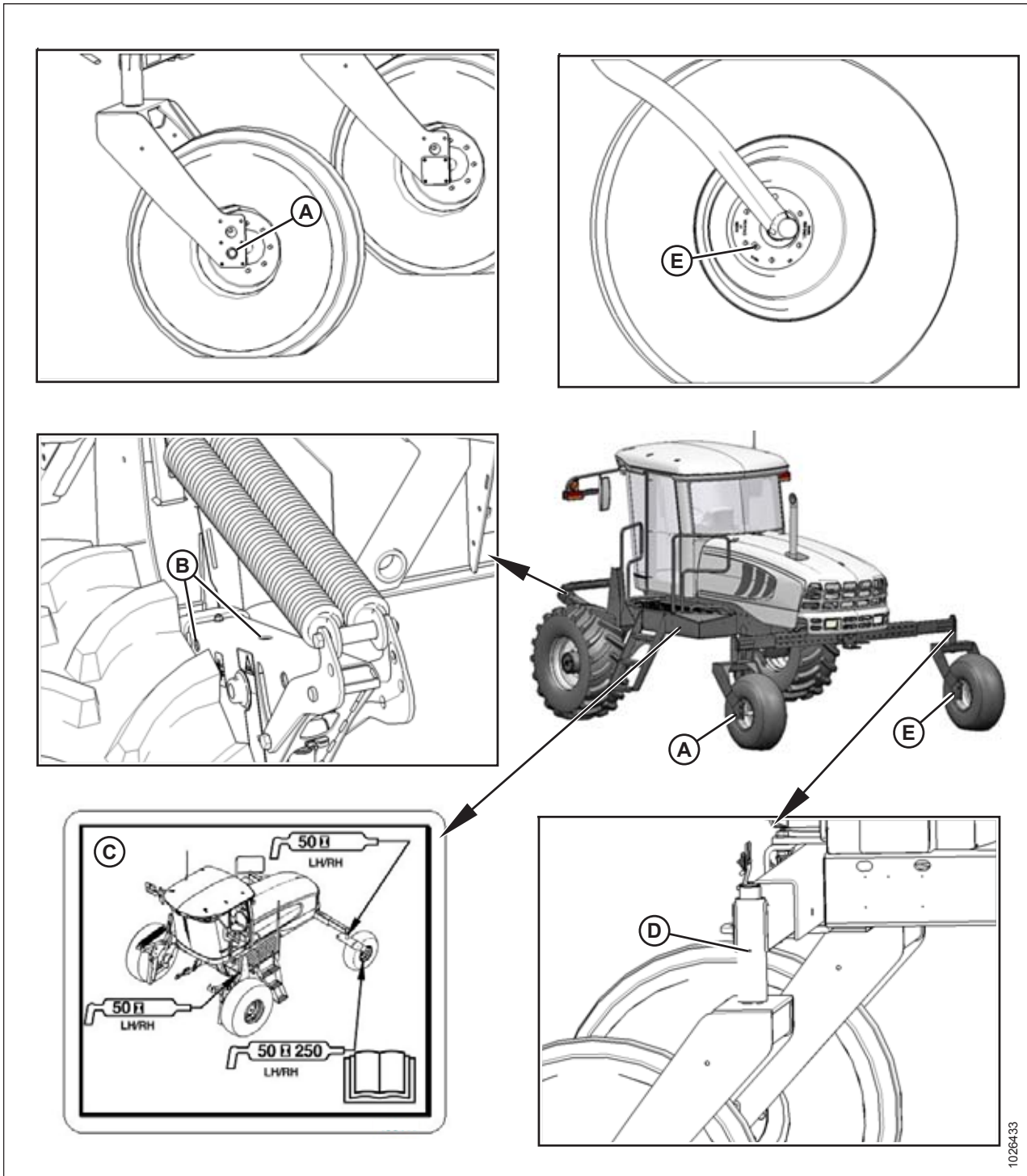

1026433

- A - Forked Caster Wheel Bearing (Two Places) (Outer – Both Wheels)
- B - Top-Link (Two Places) (Both Sides)
- C - Lubrication Decal (MD #183411)
- D - Caster Pivot (Both Sides)
- E - Forked/Formed Caster Wheel Bearing (Two Places) (Inner – Both Wheels) (50 Hrs/250 Hrs)

5.5 Operator's Station

5.5.1 Seat Belts

Seat belts are an important component of the windrower's operator safety system. The following checks and service points will ensure that seat belts are functioning properly:

- Keep sharp edges and items that can cause damage away from the belts.
- Check belts, buckles, retractors, tethers, slack take-up system, and mounting bolts for damage.
- Check that bolts are tight on the seat bracket or mounting.
- Replace all parts that have damage or wear.
- Replace belts that have cuts that can weaken the belt.
- Keep seat belts clean and dry. Clean only with a soap solution and warm water. Do **NOT** use bleach or dye on the belts, as this may weaken the material.

5.5.2 Safety Systems

Perform the following checks on the operator's presence and engine lock-out systems every year or every 500 hours of operation—whichever occurs first.

Checking Operator Presence System

The operator presence system is a safety feature designed to deactivate or alert selected systems when the Operator is not seated at the operator's station.



CAUTION

Check to be sure all bystanders have cleared the area.



CAUTION

Park on a flat, level surface with the header on the ground, the ground speed lever in N-DETENT position, and the steering wheel in locked position (centered). Wait for the CDM to beep and display an "In Park" message to confirm the park brakes have engaged.

1. With the windrower engine running, place the ground speed lever (GSL) in NEUTRAL and turn the steering wheel until it locks.
2. With everyone clear of the machine, engage header drive. Refer to [3.18.1 Header Drive Switch, page 68](#).
3. With header drive running, stand up out of the seat. In approximately 5 seconds, the header should shut off. If **NOT**, the Operator Presence System requires adjustment. See your MacDon Dealer.
4. To restart the header, move the HEADER DRIVE switch to OFF position and back to the ON position again.
5. With the engine running, position the GSL in NEUTRAL and in N-DETENT. Refer to [3.17 Windrower Controls, page 66](#).
6. Swivel the operator's station, but do **NOT** lock into position.
7. Move GSL out of N-DETENT. The engine should shut down and the display will flash LOCK SEAT BASE → CENTER STEERING WHEEL → NOT IN NEUTRAL.
8. Swivel and lock the operator's station, and the display should return to normal. If the engine does **NOT** shut down, the seat position switches require adjustment. See your MacDon Dealer.

MAINTENANCE AND SERVICING

9. With the windrower moving at less than 8 km/h (5 mph), stand up out of the seat. The cab display module (CDM) will flash NO OPERATOR on the upper line and ENGINE SHUT DOWN 5...4...3...2...1...0 on the lower line accompanied by a steady tone. At 0, the engine shuts down. If the engine does **NOT** shut down, the Operator Presence System requires adjustment. See your MacDon Dealer.
10. With the windrower moving at more than 8 km/h (5 mph), stand up out of the seat. The CDM should beep once and display NO OPERATOR on the lower line. If **NOT**, the Operator Presence System requires adjustment. See your MacDon Dealer.

Checking Engine Interlock

CAUTION

Check to be sure all bystanders have cleared the area.

1. With the engine shut down and the header drive switch engaged, try to start the engine. If the engine turns over, the system requires adjustment. See your MacDon Dealer.
2. With the engine shut down, steering wheel **NOT** centered, and the ground speed lever (GSL) in NEUTRAL, but **NOT** in N-DETENT, try to start the engine. The cab display module (CDM) will flash NOT IN NEUTRAL on the display upper line and CENTER STEERING WHEEL on the lower line, accompanied by a short beep with each flash and the engine should **NOT** start. If the engine starts, the system requires adjustment. See your MacDon Dealer.

A properly functioning system should operate as follows:

- The engine should start **ONLY** when the GSL is in N-DETENT, steering wheel is locked in the CENTER position, seat base is latched in either engine-forward or cab-forward direction, and header drive switch is in the OFF position.
- The brake should engage and the machine should **NOT** move after engine start-up, under the above conditions.
- The steering wheel should **NOT** lock with the engine running and the GSL out of the N-DETENT.
- The machine should **NOT** move with the engine running and with the steering wheel still centered, when the GSL is pulled straight out of N-DETENT (**NOT** in forward or reverse).

5.5.3 Ground Speed Lever Adjustments

Adjusting Ground Speed Lever Lateral Movement

Adjusting Ground Speed Lever Fore-Aft Movement

The ground speed lever (GSL) should remain as positioned by the Operator yet be movable without excessive force.

Adjust as follows:

1. Pull handle (A) toward the operator's seat and move the console fully forward to ease accessibility from the underside of the console.

2. Set spring dimension (B) to 32 mm (1-1/4 in.).
3. To increase the pivot resistance, turn the nut (A) clockwise to compress the spring.
4. To decrease the resistance, turn the nut (A) counterclockwise to release the spring tension.

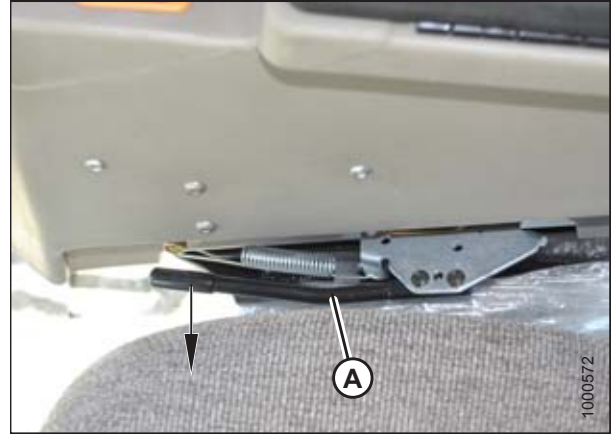

Figure 5.16: Seat Adjustment Handle

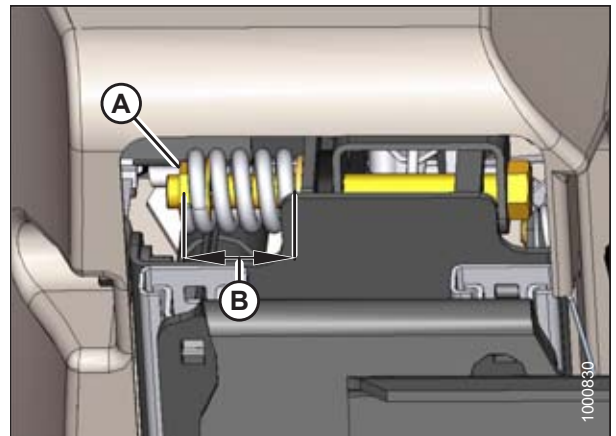

Figure 5.17: GSL Adjustment Spring

5.5.4 Steering Adjustments

Checking Steering Link Pivots

The following checks should be performed every year:

WARNING

To avoid bodily injury or death from unexpected startup of the machine, always stop the engine and remove the key from the ignition before leaving the operator's seat for any reason.

1. Place ground speed lever (GSL) (A) in N-DETENT.
2. Shut down the engine, and remove the key.



Figure 5.18: Operator Console

3. Check steering rod bolts (A) for looseness and ball joints (B) for any perceptible movement.

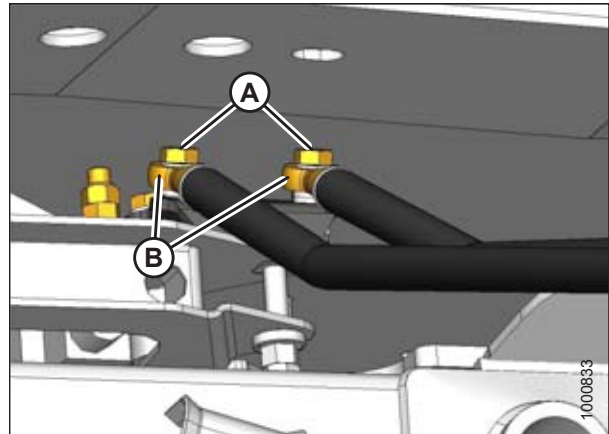

Figure 5.19: Steering Rods

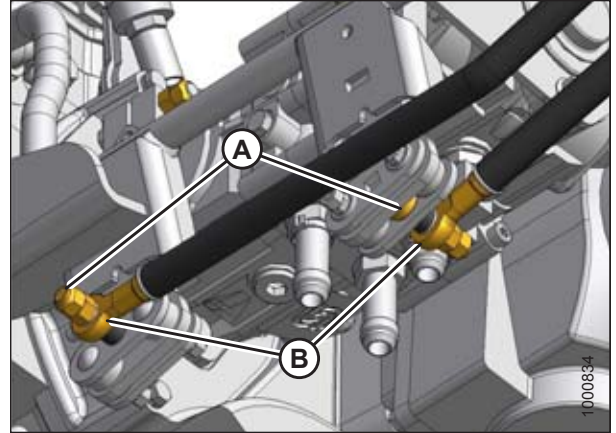

Figure 5.20: Steering Rods (Pump End)

4. Check steering link bolts (A) for looseness and ball joints (B) for any perceptible movement.

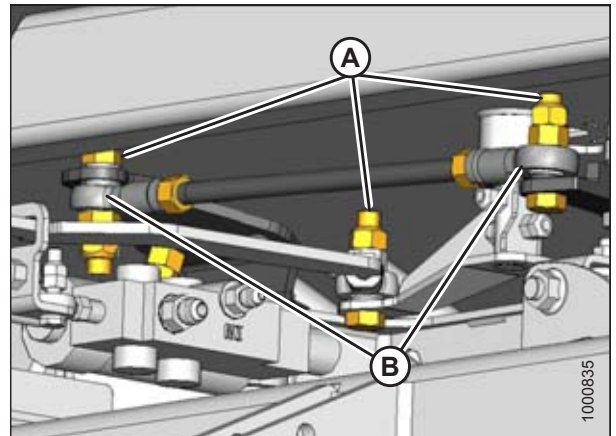

Figure 5.21: Steering Link

5. If bolts are loose:
 - a. Back off jam nut (A).
 - b. Tighten inside nut (B) to 95–108 Nm (70–80 lbf·ft).
 - c. Hold inside nut (B) and tighten jam nut (A) to 81–95 Nm (60–70 lbf·ft).

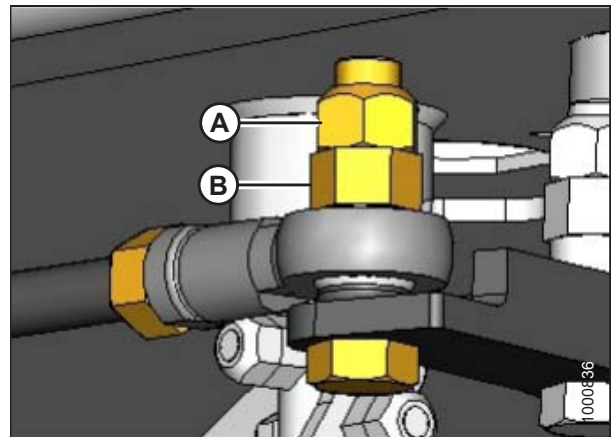

Figure 5.22: Steering Link

6. To replace loose steering link ball joints or steering rod ball joints, contact your MacDon Dealer.
7. After replacing parts or making adjustments, perform checks for neutral interlock and steering lock. Refer to [5.5.2 Safety Systems, page 325](#).

Checking and Adjusting Steering Chain Tension

⚠ WARNING

To avoid bodily injury or death from unexpected startup of the machine, always stop the engine and remove the key from the ignition before leaving the operator's seat for any reason.

1. Check steering for binding or excessive play which may be the result of the steering chain being too tight or too loose. If the steering chain does **NOT** require adjustment, skip the following steps.
2. If the chain tension requires adjustment, swivel the operator's station to position steering column close to the door.
3. At the base of the steering column, check dimension (C) at spring. It should be 16 mm (5/8 in.).
4. Adjust dimension as follows:
 - a. Loosen nut (A) and turn nut (B) to achieve 16 mm (5/8 in.) dimension (C).
 - b. Tighten nut (A) against nut (B) to secure position.
 - c. Check that steering chain is taut and steering shaft is free to rotate.

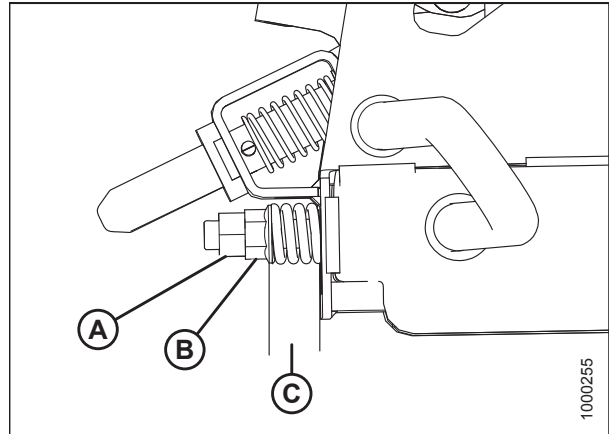

Figure 5.23: Steering Tension Adjuster

5.5.5 Park Brake

The brake is applied when the neutral interlock is fully engaged. To engage the interlock and the brake, the ground speed lever (GSL) must be in the N-DETENT position and the steering wheel centered.

5.6 Cab Suspension Limit Straps

The cab suspension limit straps are located next to the front suspension on both sides of the cab. These straps protect cab suspension components by preventing the cab shocks from fully extending. The straps do not require regular maintenance, but they should be inspected every 100 hours.

1. Inspect the material on straps (A) for fraying or tearing.
2. If material is torn or frayed, contact your MacDon Dealer for replacement straps.

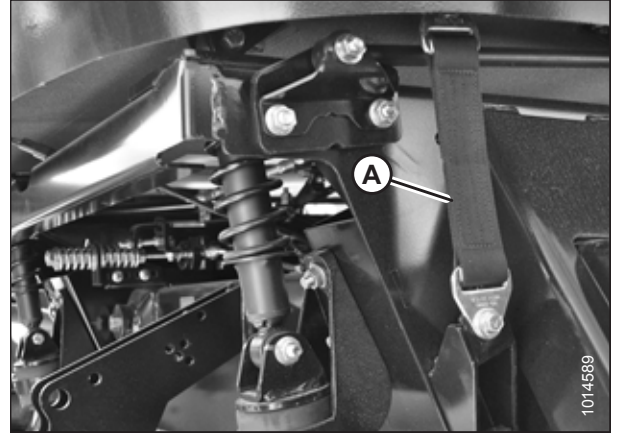

Figure 5.24: Cab Suspension

5.7 Heating, Ventilating, and Air Conditioning System

5.7.1 Fresh Air Intake Filter

The fresh air filter is located outside the right rear of the cab and should be serviced every 50 hours under normal conditions and more frequently in severe conditions.

Removing Fresh Air Filter

⚠ WARNING

To avoid bodily injury or death from unexpected startup of the machine, always stop the engine and remove the key from the ignition before leaving the operator's seat for any reason.

1. Open the right cab-forward platform. Refer to [5.3.1 Opening Platforms – Standard Position, page 318](#).
2. Rotate latch (A) and slide filter tray (B) out of the housing.

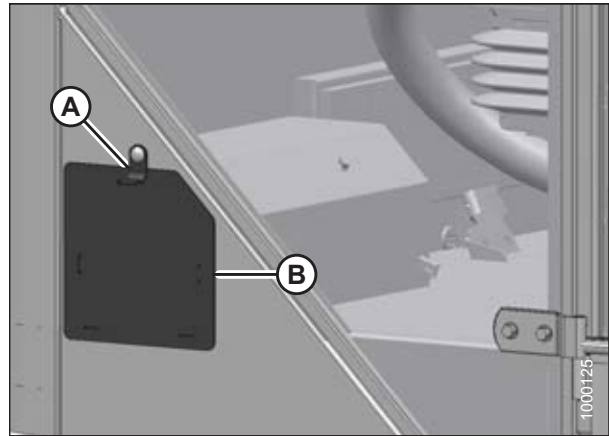

Figure 5.25: Filter Tray

3. Remove filter (A) from tray (B).

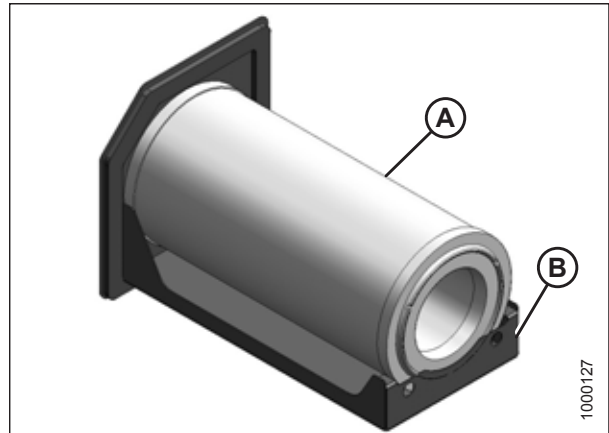

Figure 5.26: Fresh Air Filter

Inspecting and Cleaning Fresh Air Filter Element

1. Tap the sides of filter element (A) gently to loosen dirt. Do **NOT** tap element against a hard surface.
2. Using a dry element cleaner gun, clean element with compressed air.

IMPORTANT:

Air pressure must **NOT** exceed 414 kPa (60 psi). Do **NOT** direct air against outside of element, as dirt might be forced through to inside.

3. Hold the air nozzle next to the filter element's inner surface and move up and down the pleats.
4. Repeat Steps 1, page 333 to 3, page 333 to remove remaining dirt as required.
5. Hold a bright light inside the element and check carefully for holes. Discard any element that shows the slightest hole.
6. Check outer screen for dents. Vibration would quickly wear a hole in the filter.
7. Check filter gasket for cracks, tears, or other signs of damage. If gasket is damaged or missing, replace element.

Installing Fresh Air Filter

Refer to 8.2.4 Filter Part Numbers, page 480 for part number.

1. Clean tray (B) and interior of filter housing.
2. Place filter (A) onto tray (B).

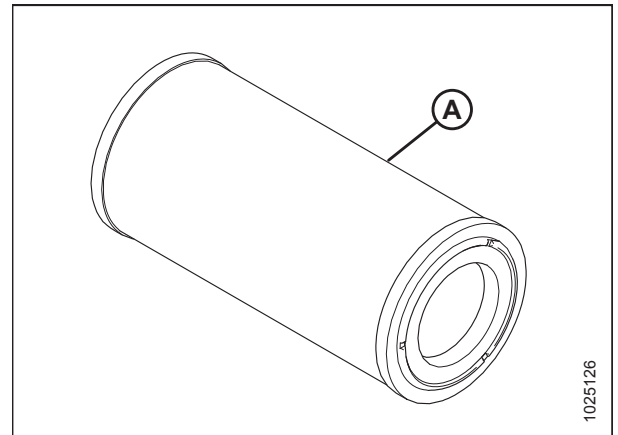

Figure 5.27: Fresh Air Filter Element

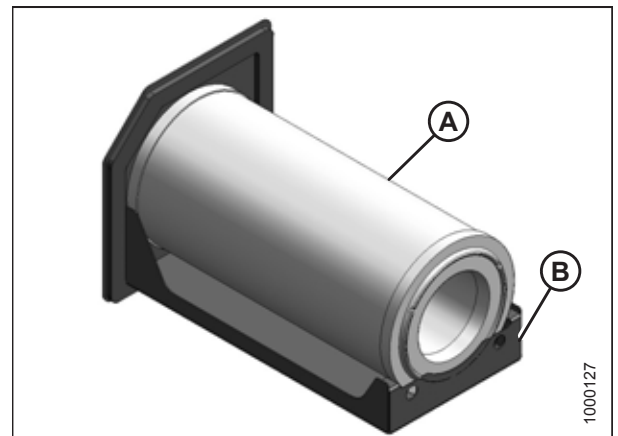

Figure 5.28: Fresh Air Filter

MAINTENANCE AND SERVICING

- Slide filter tray (B) into housing.

NOTE:

If necessary, move the Global Positioning System (GPS) wiring harnesses to the left (engine side) of the housing before inserting the filter tray.

- Close and latch housing door (A).

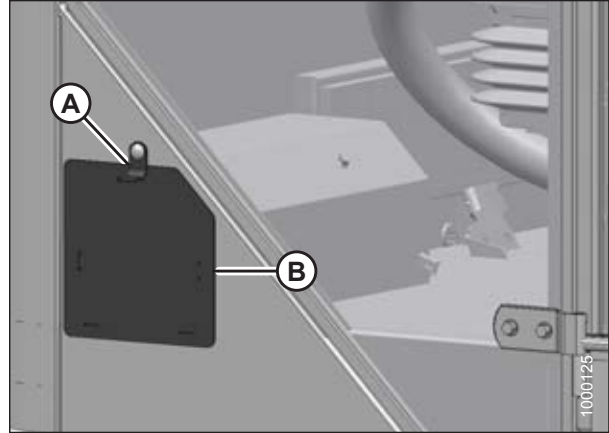

Figure 5.29: Cab Fresh Air Filter Access

5.7.2 Servicing the Return Air Cleaner/Filter

WARNING

To avoid bodily injury or death from unexpected startup of the machine, always stop the engine and remove the key from the ignition before leaving the operator's seat for any reason.

If replacing the return air filter, refer to [8.2.4 Filter Part Numbers, page 480](#) for the part number.

- Unscrew the two knobs (A) attaching cover and filter to cab wall, and remove the cover and filter assembly (B).

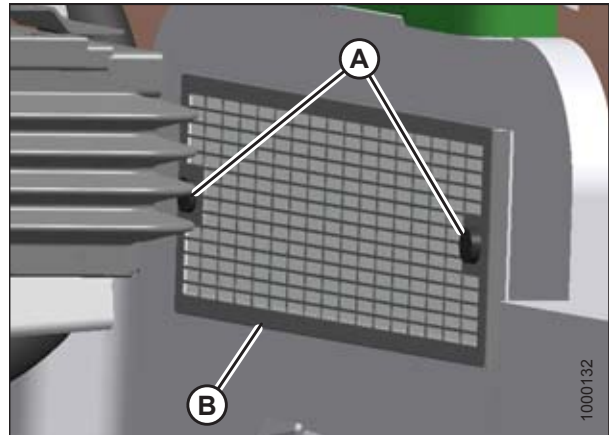

Figure 5.30: Return Air Filter

MAINTENANCE AND SERVICING

2. Separate the filter (B) from the cover (A).
3. Clean or replace the filter. If cleaning filter, refer to [Cleaning Return Air Cleaner/Filter, page 335](#).
4. Assemble the cleaner (B) and cover (A), and position on cab wall over opening.

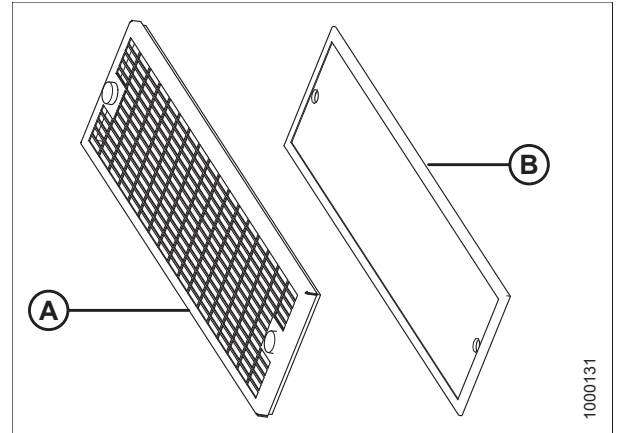

Figure 5.31: Return Air Filter

5. Secure filter assembly (B) to cab wall with knobs (A).

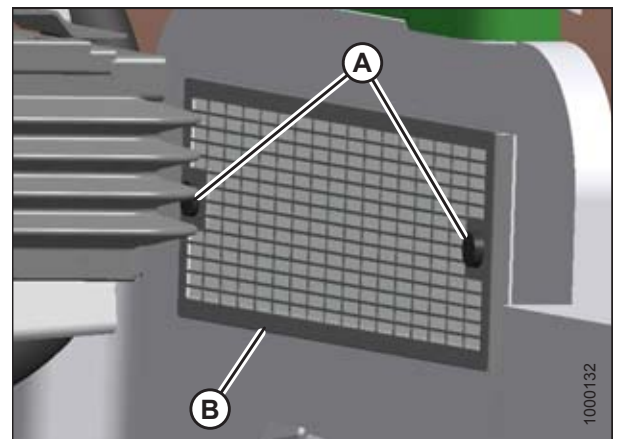

Figure 5.32: Return Air Filter

Cleaning Return Air Cleaner/Filter

Clean the electrostatic filter as follows:

1. Mix a solution of warm water and detergent in a suitable container and soak the filter (A) for a few minutes.
2. Agitate to flush out the dirt.
3. Rinse with clean water, and then dry with compressed air.
4. Inspect filter for damage, separation, and holes. Replace if damaged.

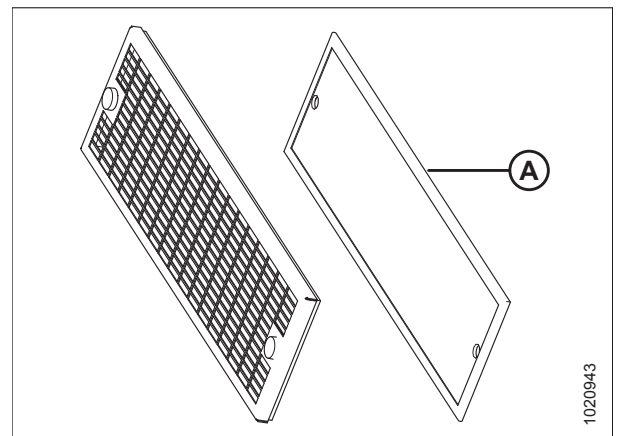

Figure 5.33: Return Air Filter

5.7.3 Air Conditioning Condenser

Clean the air conditioning condenser daily with compressed air. More frequent cleaning may be necessary in severe conditions.

Cleaning the condenser can be done at the same time as the radiator, oil cooler, and charge air cooler. Refer to *Maintaining Engine Cooling Box*, page 369.

5.7.4 Air Conditioning Evaporator Core

Check the air conditioning (A/C) evaporator annually for cleanliness. If the A/C system produces insufficient cooling, a possible cause is clogged evaporator fins. Fins will clog up from the side opposite the blowers. The evaporator is located inside the heating air conditioning unit under the cab.

Removing Air Conditioning Cover

WARNING

To avoid bodily injury or death from unexpected startup of the machine, always stop the engine and remove the key from the ignition before leaving the operator's seat for any reason.

1. Shut down the engine, and remove the key from the ignition.
2. Loosen clamps (A) on the two drain hoses connected to the A/C drain tubes, and pull the hoses off the A/C drain tubes.

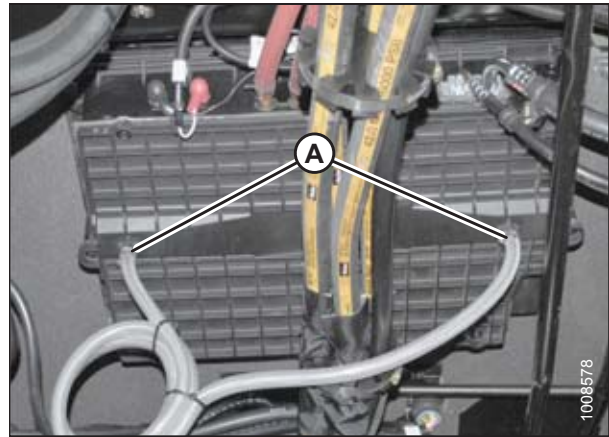

Figure 5.34: HVAC System – 2015 and Later

3. Remove the eight screws (A) that attach the cover (B), and remove the cover.

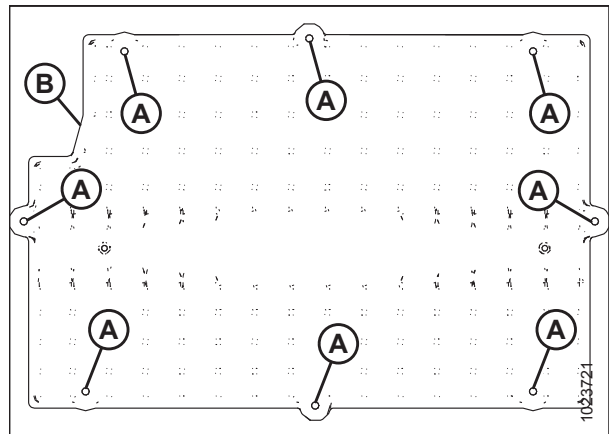

Figure 5.35: A/C Cover

Cleaning Air Conditioning Evaporator Core

WARNING

To avoid cuts from evaporator fins, do NOT use bare hands to brush away clogs.

1. Use a vacuum cleaner or compressed air to remove dirt from inside the A/C unit.
2. Blow compressed air through the evaporator fins from blower side (A) first. Direct the air straight into the evaporator to prevent fin damage. A nozzle extension makes this procedure easier.
3. Repeat Step 2, page 337 at the side (B) opposite the blowers.

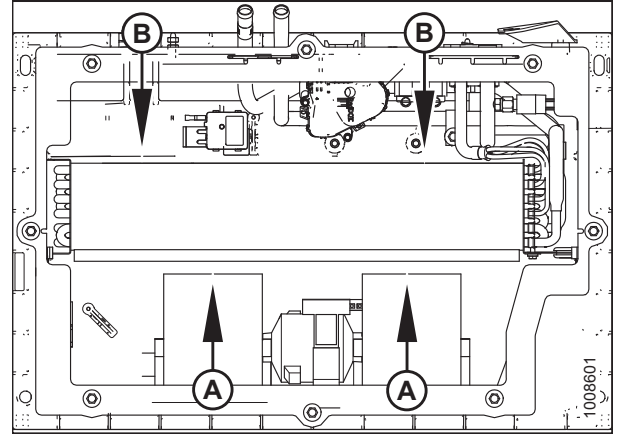

Figure 5.36: HVAC System

4. If you cannot feel the compressed air blowing through the evaporator core, proceed as follows:
 - a. Protect blower motor (A) from water.
 - b. Soak evaporator core (B) with warm water using a low pressure hose. Let soak for several minutes.
 - c. Blow compressed air through the core from blower side (C).
 - d. Repeat the soaking procedure until air blows through the evaporator freely.

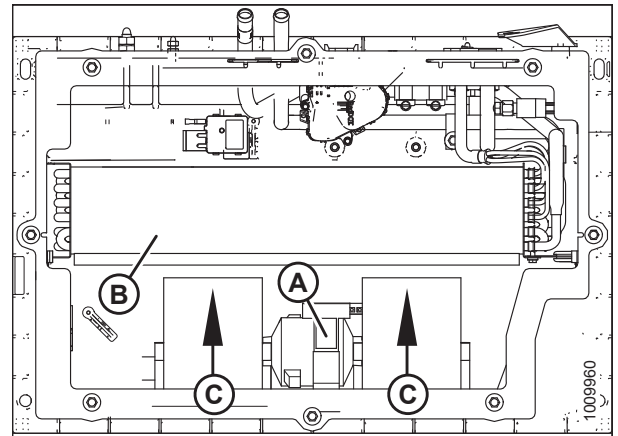

Figure 5.37: HVAC System

Installing Air Conditioning Cover

1. Straighten any bent fins.
2. Position cover (B) onto A/C unit, and attach with eight screws (A).

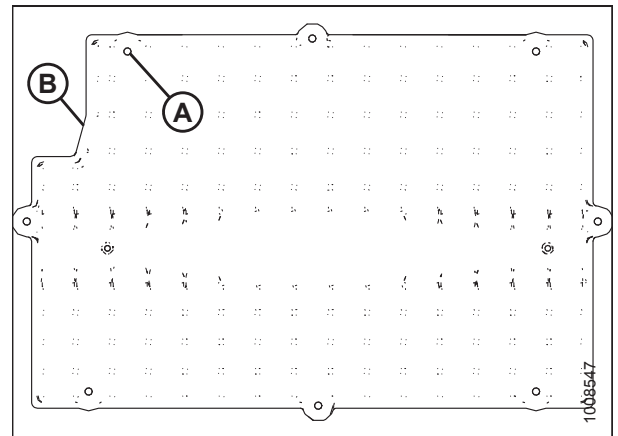

Figure 5.38: A/C Cover

3. Reattach drain hoses to drain tubes and secure with hose clamps (A).

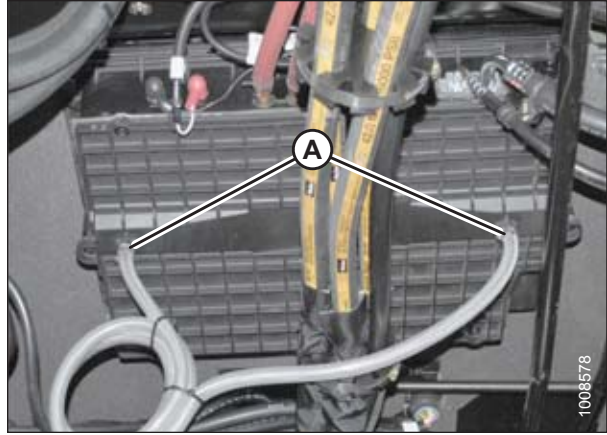

Figure 5.39: A/C Drains

5.7.5 Air Conditioning Compressor

The compressor is protected from excessively low suction and high discharge pressures by two switches that shut down the compressor to prevent damage to the system. These switches do not require regular maintenance. Contact your MacDon Dealer if you suspect a problem with the switches.

Low-pressure switch

The low-pressure switch is closed when there is sufficient refrigerant in the system and the pressure is above 234 kPa (34 psi). The system remains pressurized at about 414–483 kPa (60–70 psi) with the compressor off.

When the air conditioning (A/C) system is turned on, the compressor starts because the system pressure is above 234 kPa (34 psi). As the system gets colder, the suction pressure (low side) drops. At 24–86 kPa (3.5–12.5 psi) (for 2014 and prior: 14–55 kPa [2–8 psi]), the switch opens and shuts down the compressor.

When the pressure rises above 172 kPa (25 psi), the switch closes and the compressor restarts. The low-pressure switch is located at the outlet of the evaporator (under cab in the A/C box).

High-pressure switch

The high-pressure switch is closed when there is sufficient refrigerant in the system. The system remains pressurized at about 414–483 kPa (60–70 psi) with the compressor off.

If the pressure exceeds 2482–2620 kPa (360–380 psi) during operation, the valve opens. It will close when pressure falls below 1517–1931 kPa (220–280 psi). The high-pressure switch is located on the receiver drier (right cab-forward frame rail, behind the fuse panel).

If the compressor cycles rapidly due to rapid pressure changes, the cab display module (CDM) displays a warning CHECK A/C SYSTEM. Contact your Dealer.

Servicing the Air Conditioning Compressor

Refer to [Replacing Air Conditioner Compressor Belt](#), page 379 for belt replacement procedure.

See your MacDon Dealer for all other servicing procedures.

5.8 Engine

CAUTION

- NEVER operate engine in a closed building. Proper ventilation is required to avoid exhaust gas hazards.
- Keep the engine clean. Straw and chaff on a hot engine are a fire hazard.
- NEVER use gasoline, naphtha, or any other volatile material for cleaning purposes. These materials are toxic and/or flammable.

5.8.1 General Engine Inspection

Engine inspection should be performed by your MacDon Dealer.

Refer to your engine manual for further information (Owner's Manual QSB 4.5 and QSB 6.7 Engine Cummins #4021531 are supplied with your machine).

5.8.2 Turning the Engine Manually

To manually turn the engine with the flywheel, an access hole is provided on the left cab-forward side for a barring tool that is available from Cummins.

WARNING

To avoid bodily injury or death from unexpected startup of the machine, always stop the engine and remove the key from the ignition before leaving the operator's seat for any reason.

1. Shut down the engine, and remove the key from the ignition.
2. Open the hood to the lower position. For instructions, refer to [5.2.1 Opening Hood – Lower Position, page 314](#).
3. Move platform on the left cab-forward side of machine to open position. For instructions, refer to [5.3.1 Opening Platforms – Standard Position, page 318](#).
4. Remove positive (red) cables (A) from battery posts first, then remove negative (black) cables (B) from remaining battery posts.

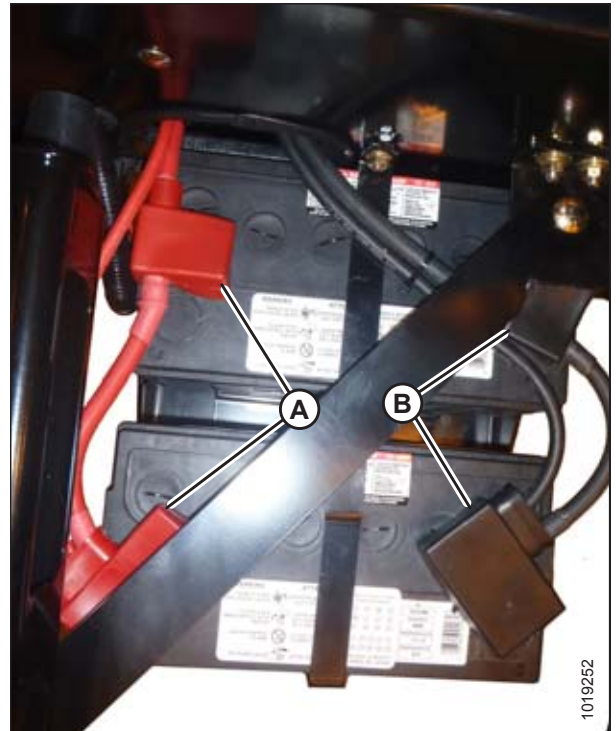

Figure 5.40: Batteries

MAINTENANCE AND SERVICING

5. Clean the area around the plastic cap on access hole (A). Remove the cap.

IMPORTANT:

Ensure nothing falls into gearbox oil reservoir.

6. Insert barring tool (B) into the flywheel housing until it engages the ring gear.
7. Attach a 1/2 in. square drive ratchet or breaker bar and turn.
8. Remove barring tool (B), and then clean oil from around access hole (A).
9. Clean plastic cap and reinstall in access hole (A) with silicone sealant.

IMPORTANT:

Batteries are negative grounded. Always connect starter cable to the positive (+) terminal of battery and battery ground cable to negative (-) terminal of battery. Reversed polarity in battery or alternator may result in permanent damage to electrical system.

10. Attach negative (black) cables (B) to negative posts on batteries, and tighten clamps. Then attach positive (red) cables (A) to positive post on batteries and tighten clamps.
11. Position plastic covers onto clamps.
12. Close the hood. Refer to [5.2.2 Closing Hood – Lower Position, page 315](#).
13. Close the platform. Refer to [5.3.2 Closing Platforms – Standard Position, page 319](#).

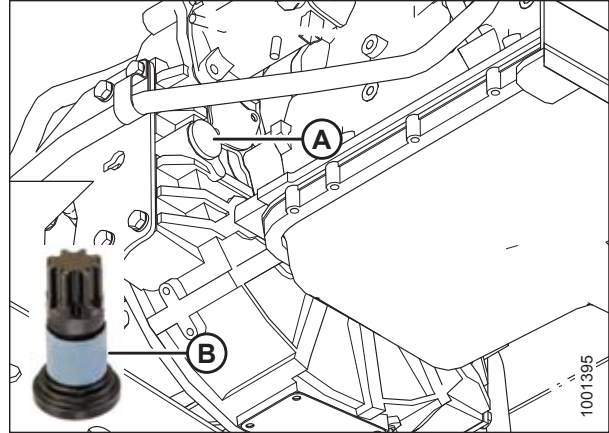

Figure 5.41: Access Hole Location for Barring Tool

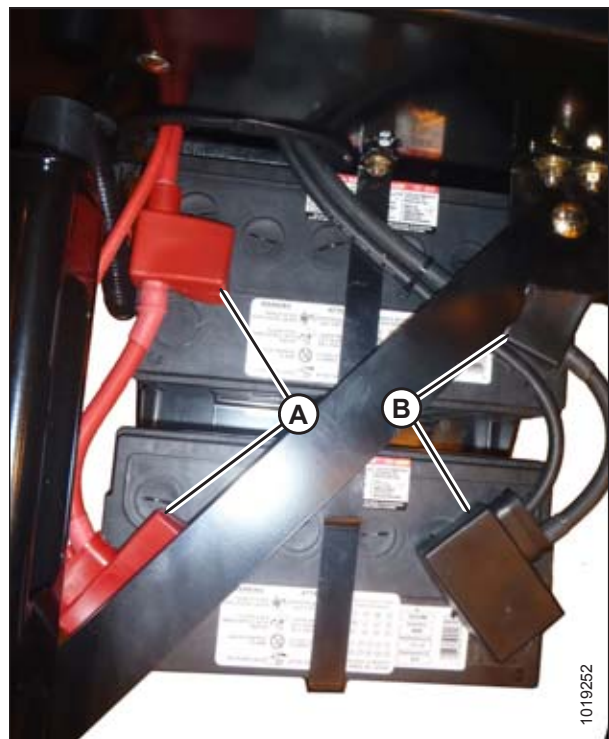

Figure 5.42: Batteries

5.8.3 Engine Oil

Checking Engine Oil Level

Check engine oil level daily (every 10 hours) and watch for any signs of leakage.

CAUTION

To avoid bodily injury or death from unexpected startup of machine, always stop engine and remove key from ignition before leaving operator's seat for any reason.

NOTE:

During the break-in period, a higher than usual oil consumption should be considered normal.

1. Open the hood to the lower position. For instructions, refer to [5.2.1 Opening Hood – Lower Position, page 314](#).
2. Operate the engine at low idle and check for leaks at the filter and drain plug.
3. Shut down the engine, and remove the key from the ignition.
4. Remove dipstick (A) by turning it counterclockwise to unlock.
5. Wipe the dipstick clean and reinsert it into the engine.
6. Remove the dipstick again and check the oil level.

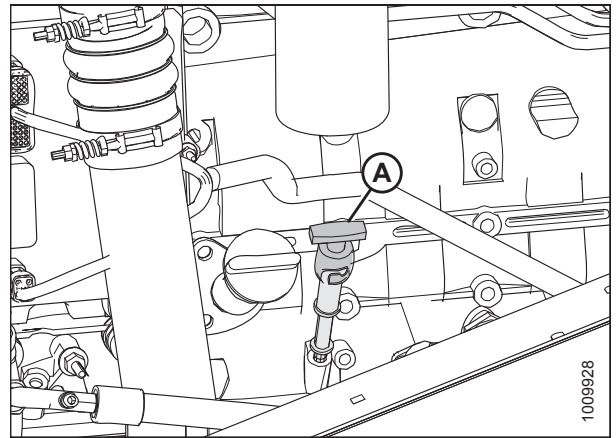

Figure 5.43: Engine Oil Dipstick

7. Add oil if level is below low (L) mark. For instructions, refer to [Adding Engine Oil, page 344](#).

IMPORTANT:

Oil level should be maintained between low (L) and high (H) mark on the dipstick.

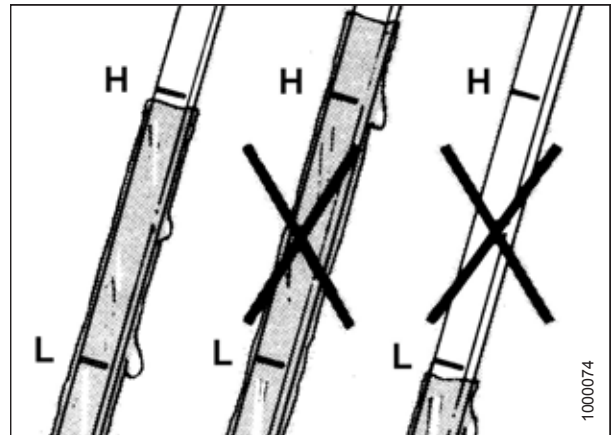

Figure 5.44: Engine Oil Level

MAINTENANCE AND SERVICING

8. Replace dipstick (A) and turn it clockwise to lock.
9. Close the hood. For instructions, refer to [5.2.2 Closing Hood – Lower Position, page 315](#).

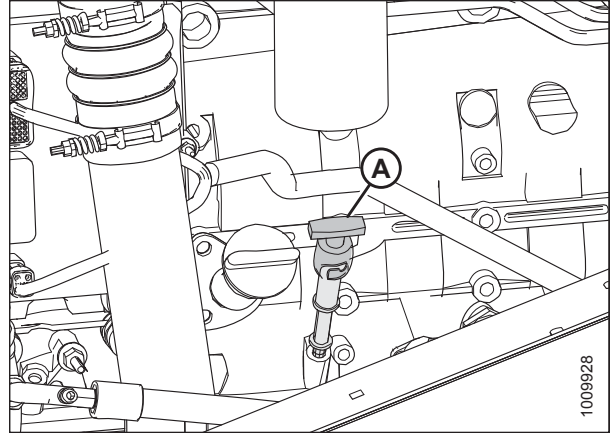

Figure 5.45: Engine Oil Dipstick

Changing Engine Oil

Refer to the following procedures:

- [Checking Engine Oil Level, page 341](#)
- [Draining Engine Oil, page 343](#)
- [Replacing Engine Oil Filter, page 344](#)
- [Adding Engine Oil, page 344](#)

Draining Engine Oil

WARNING

To avoid bodily injury or death from unexpected startup of the machine, always stop the engine and remove the key from the ignition before leaving the operator's seat for any reason.

NOTE:

The engine should be warm when you change the oil.

1. Shut down the engine, and remove the key from the ignition.
2. Place a drain pan with a capacity of about 24 liters (6 US gallons) under the engine oil drain.
3. Remove oil drain plug (A) and allow the oil to drain.
4. When all of the oil has drained out of the tank, replace drain plug (A).
5. Check the condition of the used oil. If either of the following is evident, have your Dealer correct the problem before starting the engine:
 - Thin black oil indicates fuel dilution.
 - Milky discoloration indicates coolant dilution.
6. Properly dispose of used oil.

NOTE:

Replace oil filter each time engine oil is changed. For instructions, refer to [Replacing Engine Oil Filter, page 344](#).

IMPORTANT:

Do **NOT** run engine without oil in the crankcase. For instructions, refer to [Adding Engine Oil, page 344](#).

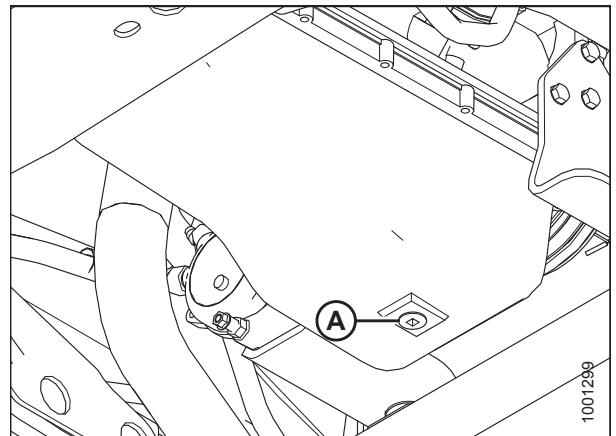

Figure 5.46: Engine Oil Drain Plug

Replacing Engine Oil Filter

NOTE:

Replace oil filter each time engine oil is changed. For instructions, refer to [8.2.4 Filter Part Numbers, page 480](#) for recommended oil filter to use.

1. Open the hood. For instructions, refer to [5.2.1 Opening Hood – Lower Position, page 314](#).
2. Clean around filter head (A).
3. Remove filter (B).
4. Clean gasket mating surface.
5. Apply a thin film of clean oil to the gasket on the new filter.

6. Screw the new filter onto the filter mount until the gasket contacts the filter head.
7. Tighten the filter an additional 1/2 to 3/4 turn by hand.

IMPORTANT:

Do **NOT** use a filter wrench to install the oil filter. Overtightening can damage the gasket and filter.

8. Properly dispose of used filter.

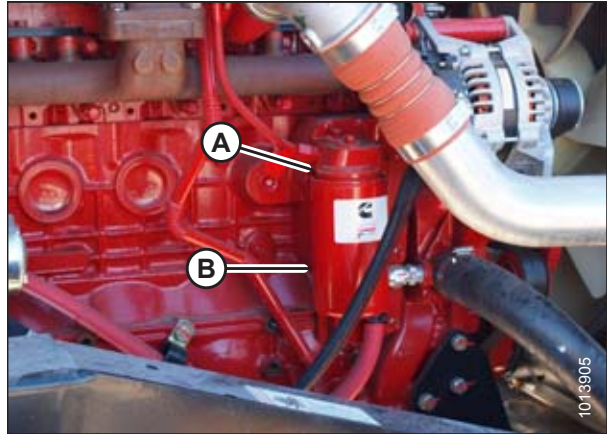

Figure 5.47: Engine Oil Filter

Adding Engine Oil

Refer to [8.2.3 Lubricants, Fluids, and System Capacities, page 479](#) for recommended lubricants.

WARNING

To avoid injury or death from unexpected start-up of machine, always stop the engine and remove the key from the ignition before leaving the operator's seat for any reason.

1. Shut down the engine, and remove the key from the ignition.
2. Open the hood to the lower position. For instructions, refer to [5.2.1 Opening Hood – Lower Position, page 314](#).
3. Remove filler cap (A) by turning it counterclockwise.
4. Carefully pour in the new oil. Use a funnel to avoid spillage.

CAUTION

Do **NOT** fill above the HIGH mark.

5. Replace oil filler cap (A) and turn it clockwise until snug.
6. Check the oil level. For instructions, refer to [Checking Engine Oil Level, page 341](#).
7. Close the hood. Refer to [5.2.2 Closing Hood – Lower Position, page 315](#).

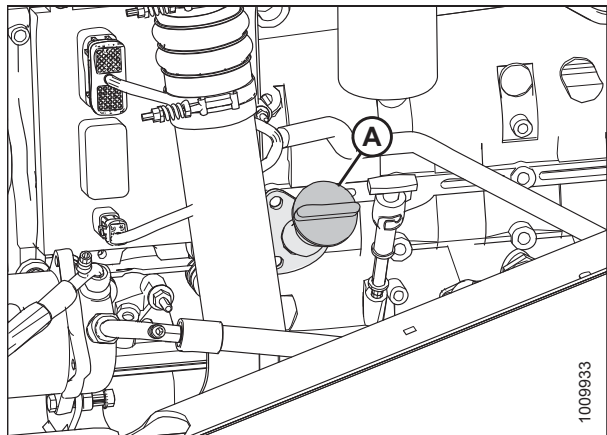

Figure 5.48: Oil Filler Cap

5.8.4 Engine Air Intake System

North America Only: Engine intake air is drawn through a duct (A) from the cooling box that pre-cleans the air, and then through a dual element filter (B). The air cleaner canister is equipped with an aspirator (C) that continuously removes dust from the air cleaner housing. The air cleaner is also equipped with a restriction switch (D) which activates a warning light on the cab display module (CDM) with an alarm when the primary filter element requires cleaning.

IMPORTANT:

Do **NOT** run the engine with the air cleaner disconnected or disassembled.

If you need to replace filters, refer to [8.2.4 Filter Part Numbers, page 480](#).

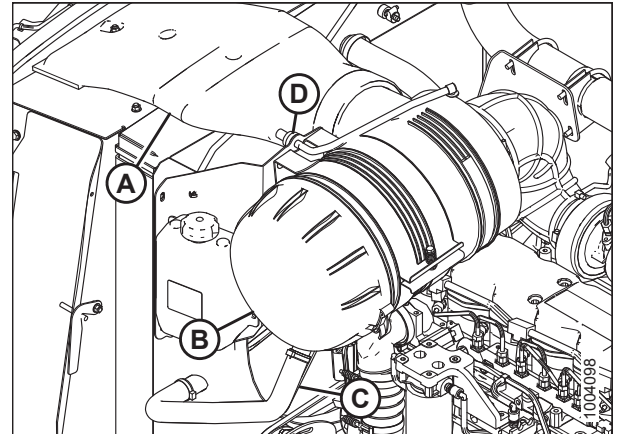

Figure 5.49: Engine Air Intake (North America)

Export Only: Engine intake air is drawn through a duct (A) from the hood mounted pre-cleaner that pre-cleans the air, and then through a dual element filter (B). The air cleaner canister is equipped with an aspirator (C) that continuously removes dust from the air cleaner housing. The air cleaner is also equipped with a restriction switch (D) which activates a warning light on the cab display module (CDM) with an alarm when the primary filter element requires cleaning.

IMPORTANT:

Do **NOT** run the engine with air cleaner disconnected or disassembled.

If you need to replace filters, refer to [8.2.4 Filter Part Numbers, page 480](#).

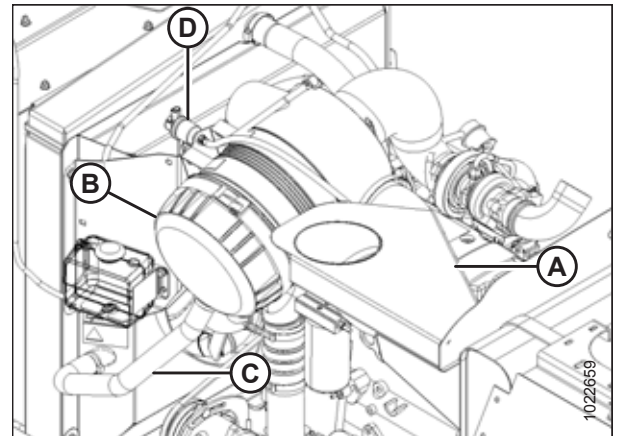

Figure 5.50: Engine Air Intake (Export)

Air Filter Restriction Indicator

During engine operation, the indicator shows the vacuum in inches of H₂O and kPa. As dirt accumulates in the filter, the restriction increases.

When the indicator gauge reaches the CHANGE FILTER mark (A), 25 in. of H₂O (6.20 kPa), a warning tone will sound and the cab display module (CDM) will indicate the filter requires servicing.

IMPORTANT:

Over-servicing the filter element increases the risk of dirt being ingested by the engine, causing severe damage.

Service air filter **ONLY IF** indicator reaches the CHANGE FILTER mark (A) or 25 in. H₂O (6.20 kPa).

IMPORTANT:

After servicing filters, press the RESET button on the end of the indicator (B).



Figure 5.51: Air Filter Restriction Indicator

MAINTENANCE AND SERVICING

Removing Primary Air Filter

1. Open the hood. Refer to [5.2.1 Opening Hood – Lower Position, page 314](#).
2. Open the maintenance platform on right cab-forward side. Refer to [5.3.1 Opening Platforms – Standard Position, page 318](#).
3. Slightly lift catch (A) at side of end cap (B) and rotate end cap counterclockwise until it stops.

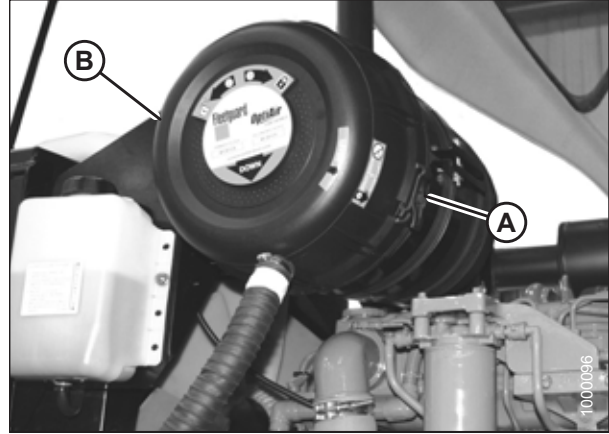

Figure 5.52: Engine Air Cleaner

4. Make sure arrow (A) lines up with UNLOCK symbol on end cap.
5. Pull off the end cap.

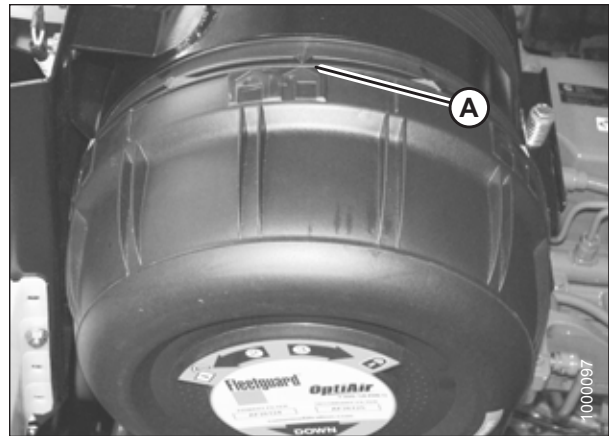

Figure 5.53: Engine Air Cleaner

6. Check the aspirator duct opening (A) for obstructions or damage. Clean if necessary.

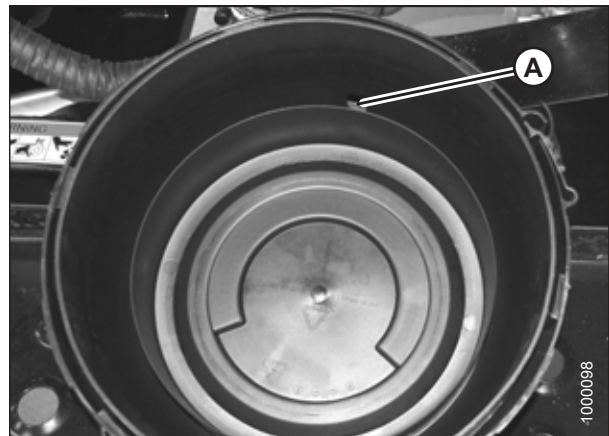

Figure 5.54: Engine Air Cleaner Housing

MAINTENANCE AND SERVICING

7. Pull out the primary filter element (A).

IMPORTANT:

Be extremely careful with the dirty element until it is completely out of the housing. If you accidentally bump the element while it is still inside the filter housing, dirt and dust may contaminate the clean side of the housing.

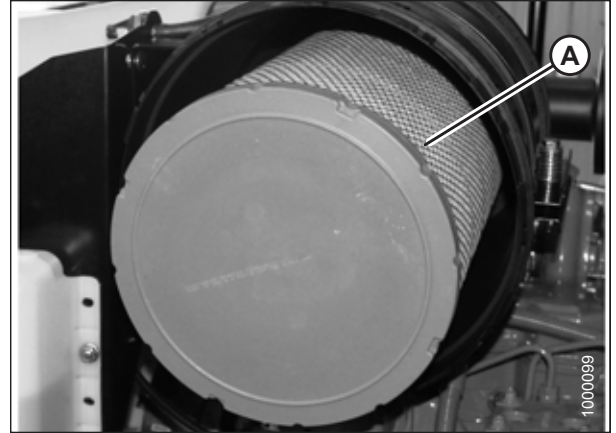

Figure 5.55: Engine Air Cleaner Primary Filter Element

IMPORTANT:

Replace the secondary air filter (A) every year or after every third primary filter change (even if it appears clean).

8. If the secondary air filter is dirty, inspect the primary filter and the filter canister as follows to determine the reason for contamination:
 - Examine the filter canister for cracks, and replace if necessary.
 - Ensure filter sealing surfaces are soft, flexible, and sealing properly. Hard seals may allow debris through to the secondary filter.
 - Ensure canister retaining latches are secure.

IMPORTANT:

- Do **NOT** remove the secondary filter element unless it needs replacing.
- Do **NOT** attempt to clean the secondary element. The secondary element is to be replaced only.

9. If required, replace the secondary filter. Refer to *Removing and Installing Secondary Air Filter, page 351*.
10. Clean the inside of the canister housing and end cap carefully. Dirt left in the air cleaner housing may be harmful to your engine.
 - Remove hardened dirt ridges wherever filter gaskets contact the cleaner housing.
 - Clean the gasket sealing surfaces of the housing. An improper gasket seal is one of the most common causes of engine contamination.
 - Wipe every surface with a clean, water-dampened cloth.
 - Check the housing visually to make sure it is clean before putting in a new filter element.

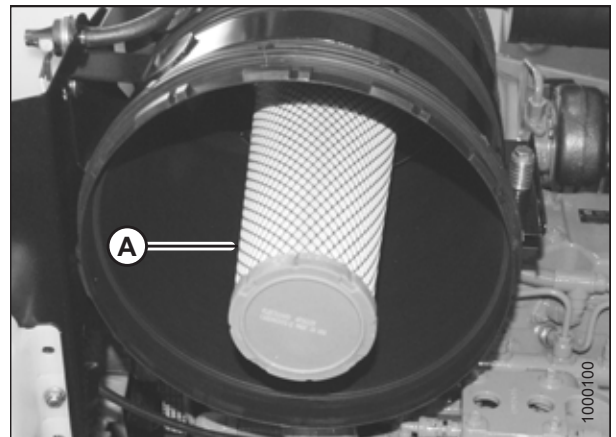

Figure 5.56: Engine Air Cleaner Secondary Filter Element

MAINTENANCE AND SERVICING

11. Check for uneven dirt patterns on old element. They are a valuable clue to potential dust leakage or gasket sealing problems. A pattern on the element clean side is a sign that the old element was **NOT** firmly sealed or that a dust leak exists.
 - Press on the fresh gasket to see if it springs back.
 - Check the gasket for correct sizing. On a radial seal element, the gasket surface is the inside diameter of the open end cap.
 - Make sure the gasket is seating evenly. If the gasket is not forming a perfect seal, you will **NOT** have protection.
 - Ensure the sealing surface in the housing is clean, and the filter element is the correct model number. It may be too short for the housing.
 - Identify and rectify the cause of any leaks before replacing the filter element.

Installing Primary Air Filter

NOTE:

If replacing air filter, refer to [8.2.4 Filter Part Numbers, page 480](#).

1. Insert new primary filter element (A) into canister over secondary element, and push into place, ensuring that element is firmly seated in canister.
2. Align arrow (A) with UNLOCK symbol on end cap, and push end cap fully onto housing.
3. Rotate end cap clockwise until catch (A) engages housing to prevent end cap from turning.

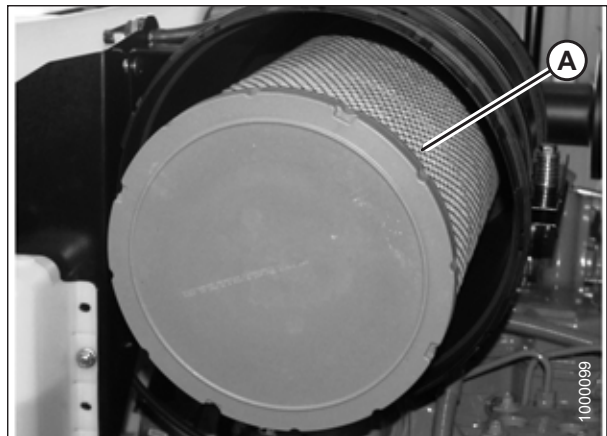

Figure 5.57: Primary Filter Element



Figure 5.58: Engine Air Cleaner

MAINTENANCE AND SERVICING

4. Position end cap (B) onto filter housing with aspirator pointing approximately down.
5. Secure end cap onto filter housing by closing catch (A).

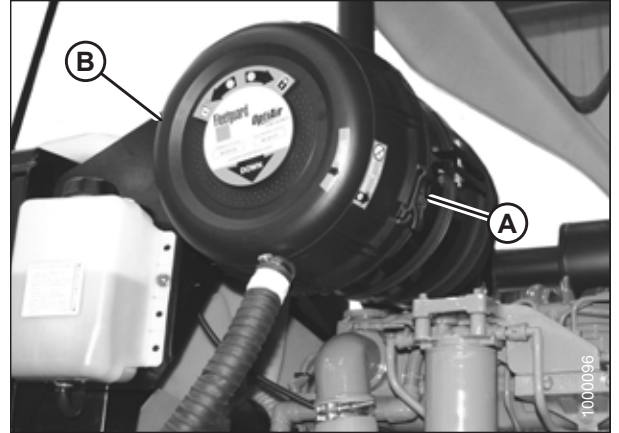

Figure 5.59: Engine Air Cleaner

6. After servicing the filter, reset the restriction switch (A) by pushing the button on the end.
7. Close the hood. Refer to [5.2.2 Closing Hood – Lower Position, page 315](#).
8. Close the maintenance platform. Refer to [5.3.1 Opening Platforms – Standard Position, page 318](#).

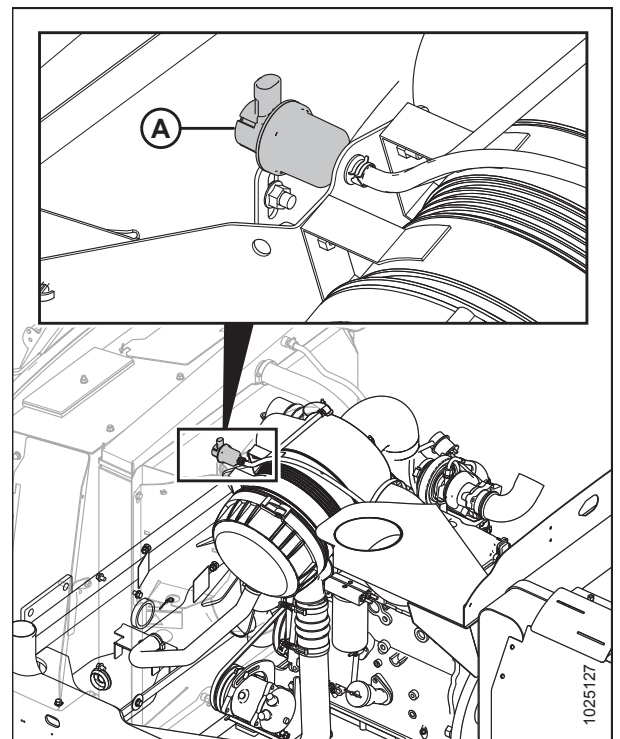

Figure 5.60: Engine Air Cleaner

MAINTENANCE AND SERVICING

Cleaning Engine Air Filter Primary Element

IMPORTANT:

The secondary (inner) element should NEVER be cleaned, only replaced.

IMPORTANT:

Air filter element cleaning is **NOT** recommended due to the possible degradation of the element material. If cleaning is performed, there are several risks involved and the following procedure should be followed. If any of the following conditions are found, the filter element **MUST** be replaced.

1. Hold a bright light inside element, and check carefully for holes.
2. Check outer screen for dents. Vibration will quickly wear a hole in the filter.
3. Check filter gasket for cracks, tears, or other signs of damage.
4. Check element for oil or soot contamination.
5. Check the secondary element for cleanliness. If there is visible dirt on the secondary element, replace both primary and secondary elements. Do **NOT** clean.

IMPORTANT:

The air cleaner's primary (outer) filter element should be replaced after three cleanings or at the specified interval. The secondary (inner) element should be replaced every third time the primary element is changed. Refer to [5.12 Maintenance Schedule, page 442](#) for the required interval.

6. If secondary element passes inspection, clean primary element as follows:
 - a. Use compressed air **NOT** exceeding 400 kPa (60 psi), and a dry element cleaner gun.
 - b. Hold nozzle next to inner surface only, and move up and down on pleats.
 - c. After three cleanings (or at the specified interval), replace the primary element.
7. Repeat inspection before reinstalling filter element.

Removing and Installing Secondary Air Filter

NOTE:

Refer to [8.2.4 Filter Part Numbers, page 480](#) for replacement filter part number.

Replace the secondary air filter (A) every year or after every third primary filter change, even if it appears clean.

If the secondary air filter is dirty, inspect the primary filter and the filter canister to determine the reason for contamination.

- Examine the filter canister for cracks and replace if necessary.
- Ensure filter sealing surfaces are soft, flexible, and sealing properly. Hard seals may allow debris through to the secondary filter.
- Ensure canister retaining latches are secure.

NOTE:

- Do **NOT** remove the secondary filter element unless it needs replacing. For secondary filter part number, refer to [8.2.4 Filter Part Numbers, page 480](#).
- Do **NOT** attempt to clean the secondary element. The secondary element is replace-only.

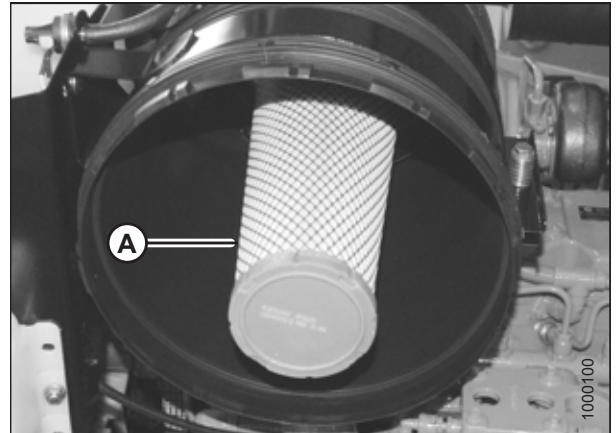

Figure 5.61: Secondary Filter Element

MAINTENANCE AND SERVICING

1. Remove the primary filter. Refer to *Removing Primary Air Filter, page 346*.

IMPORTANT:

When replacing secondary filter, reinsert new filter as soon as possible to prevent dirt from entering engine intake. Do **NOT** remove secondary filter unless a replacement is available for installation.

2. Remove secondary element (A) from canister.
3. Insert new secondary filter element (A) into canister, seal first, and push until seal is seated inside canister.
4. Reinstall the primary filter. Refer to *Installing Primary Air Filter, page 348*.

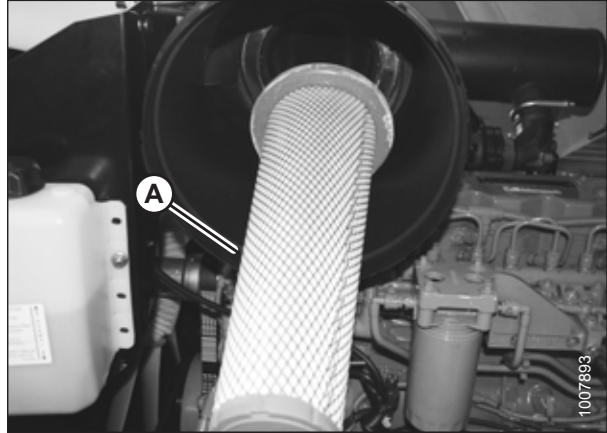

Figure 5.62: Secondary Filter Element

Air Precleaner

The engine air precleaner (A) is attached to the engine compartment hood, and in the closed position, it is sealed to the engine air intake duct in the engine compartment. There are no scheduled servicing requirements other than to ensure the intake is not blocked.

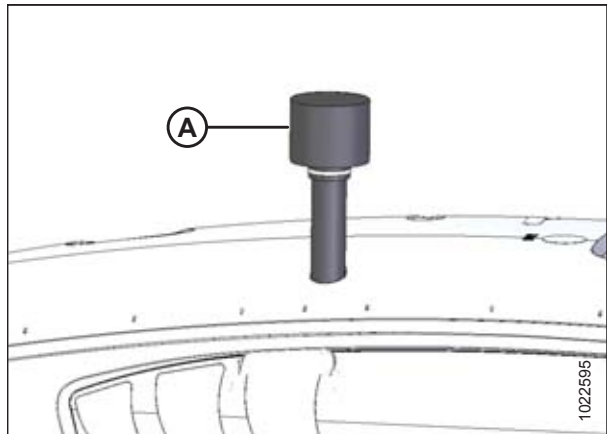

Figure 5.63: Engine Air Precleaner

5.8.5 Fuel System

Replacing Fuel Tank Vent Filter

The fuel tank is vented by a hose that is connected to the filler tube. The hose is connected to a filter that should be changed every year.

For fuel tank vent filter replacement part number, refer to [8.2.4 Filter Part Numbers, page 480](#).

WARNING

To avoid bodily injury or death from unexpected startup of the machine, always stop the engine and remove the key from the ignition before leaving the operator's seat for any reason.

WARNING

To avoid personal injury or death from explosion or fire, do NOT smoke or allow flame or sparks near windrower when servicing.

1. Shut down the engine, and remove the key from the ignition.
2. Open the hood to the highest position. For instructions, refer to [5.2.3 Opening Hood – Highest Position, page 316](#).
3. Open the right cab-forward side maintenance platform. For instruction, refer to [5.3.1 Opening Platforms – Standard Position, page 318](#).
4. Locate filter (A) on vent line against hydraulic oil reservoir.
5. Release hose tension clamps (B) and slide away from filter. Pull the hoses off of the filter.
6. Position the new filter through the hole in frame and attach top hose onto the filter. The IN marking on the filter should face down.

NOTE:

If the filter has an arrow instead of an IN marking, the arrow should point up.

7. Attach the lower hose to the filter and secure both of the hoses with tension clamps (B).

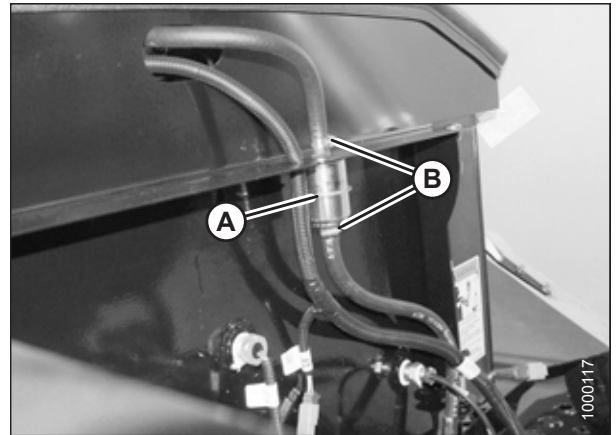

Figure 5.64: Fuel Tank Vent

8. Close the hood from the highest position. For instructions, refer to [5.2.4 Closing Hood – Highest Position, page 317](#).
9. Close the platform. For instructions, refer to [5.3.2 Closing Platforms – Standard Position, page 319](#).

Maintaining Fuel Filters

The windrower fuel system is equipped with primary (A) and secondary (B) screw-on cartridge type filters. The primary filter (A) is equipped with a separator that separates sediment and water from the fuel.

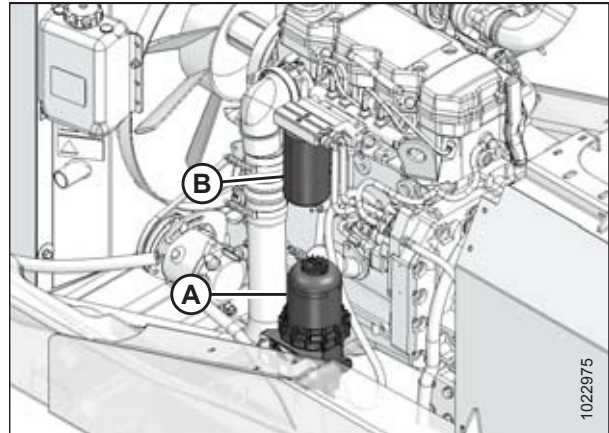

Figure 5.65: Fuel System Filters

Primary filter should be changed once the element is completely covered with fuel.

1. When new, the fuel level in the filter will be very low with minimal restriction. As the filter is used, contaminants collect on the filter from the bottom up. Fuel rises on the filter indicating remaining filter life.
2. Fuel level increases in clear cover. As contaminants collect on the filter, the fuel rises to a non-contaminated section of the filter, providing optimal filtration while maintaining lowest restriction.
3. Fuel level at filter wrap level. Even though the fuel level is now more than half of the filter element, the fuel is still flowing through clean media at minimal restriction levels. The filter still has significant life remaining.
4. The filter element is now completely covered by fuel. At this point, all of the media's surface area is utilized. Restriction is increasing and the filter element should be changed at the next scheduled maintenance interval.

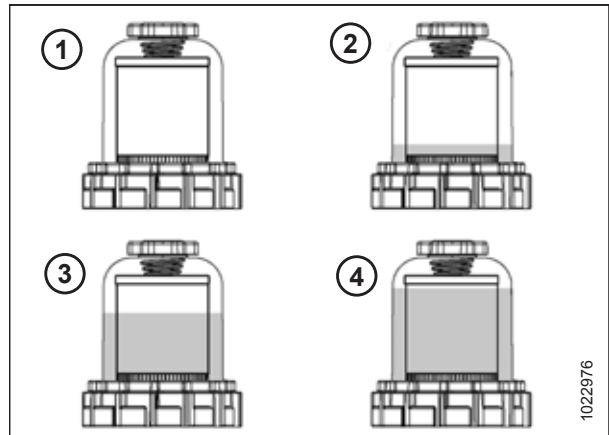

Figure 5.66: Primary Fuel Filter — Fuel Level

Refer to the following procedures:

- [Removing Primary Fuel Filter, page 355](#)
- [Installing Primary Fuel Filter, page 357](#)
- [Removing Secondary Fuel Filter, page 359](#)
- [Installing Secondary Fuel Filter, page 359](#)

Removing Primary Fuel Filter

⚠ WARNING

To avoid bodily injury or death from unexpected startup of the machine, always stop the engine and remove the key from the ignition before leaving the operator's seat for any reason.

1. Shut down the engine, and remove the key from the ignition.
2. Open the hood to the highest position. For instructions, refer to [5.2.3 Opening Hood – Highest Position, page 316](#).
3. On the bottom of the fuel tank, locate fuel supply valve (A) and move it to the closed position.

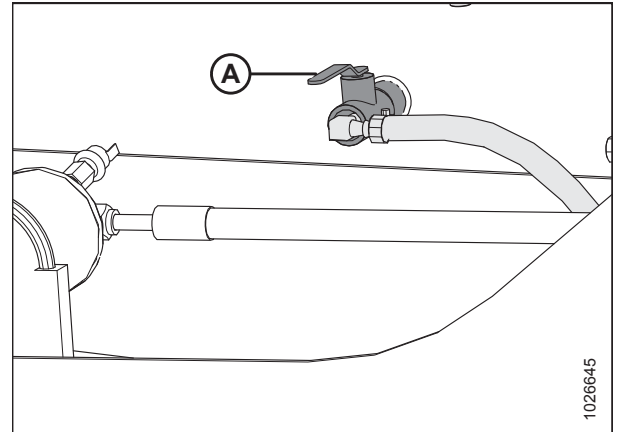

Figure 5.67: Fuel Shut-off Valve

4. Locate primary fuel filter (A) on the right cab-forward side of the windrower.

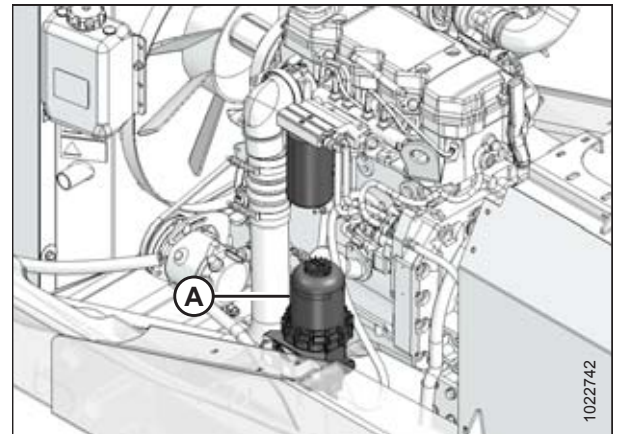

Figure 5.68: Primary Fuel Filter Location

MAINTENANCE AND SERVICING

5. Clean around the primary filter (A) head.
6. Disconnect the water in fuel (WIF) sensor from bottom of filter housing.
7. Remove vent cap (B) and turn valve (C) by hand counterclockwise and drain filter into a container.
8. Close valve (C).
9. Remove collar (D) with a filter wrench³⁵.
10. Remove clear cover (E).

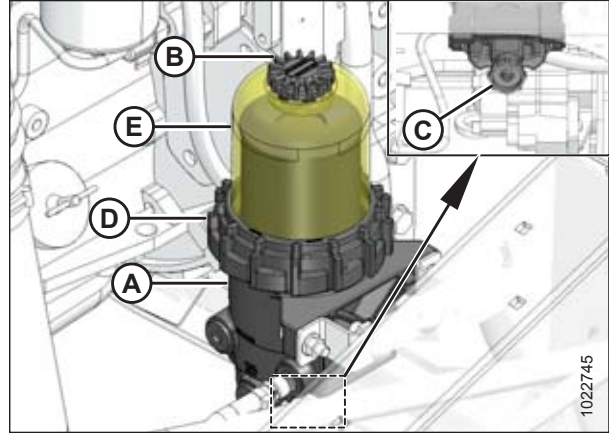

Figure 5.69: Primary Fuel Filter

11. Remove filter (A), cover O-ring (B)³⁶, and vent cap O-ring (C)³⁶. Discard filter and O-rings.

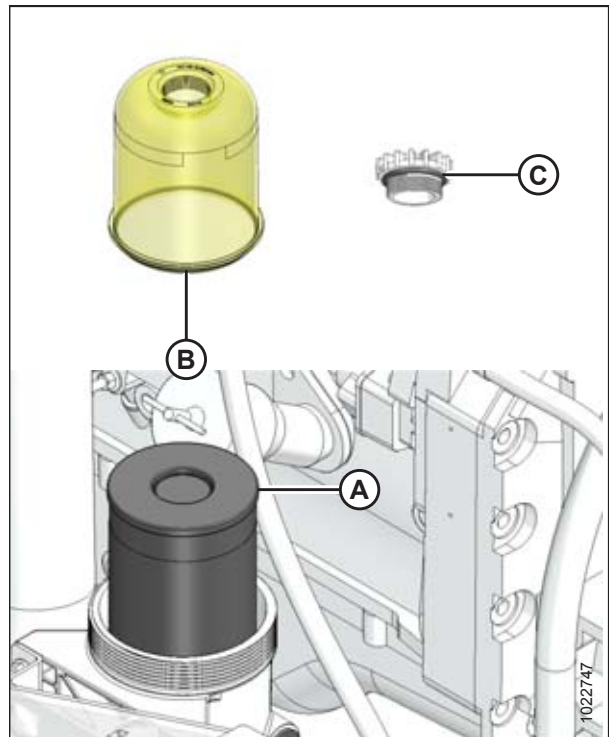

Figure 5.70: Primary Fuel Filter

35. Available from Cummins 3944458 S.

36. Only if using greater than B5 fuel.

Installing Primary Fuel Filter

For primary fuel filter replacement part number, refer to [8.2.4 Filter Part Numbers, page 480](#).

1. Clean cover (A), collar (B), and threads (C) on filter body.
2. Install new filter (D).

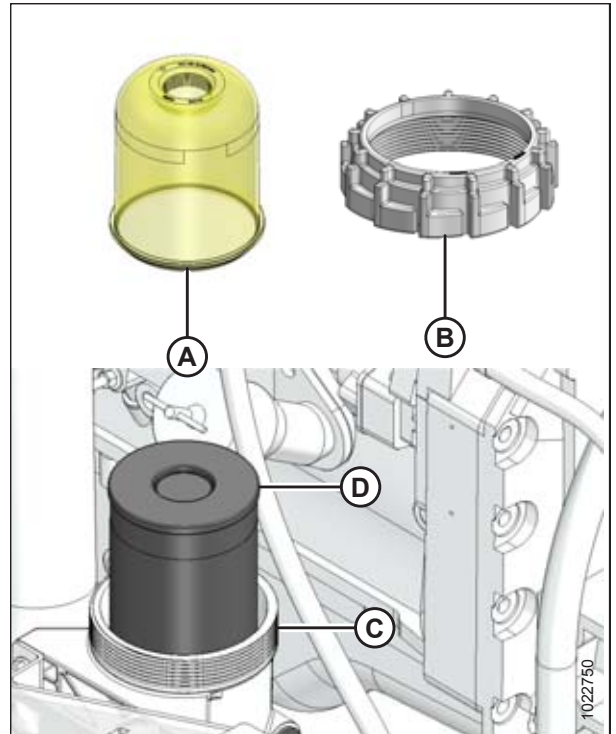

Figure 5.71: Primary Fuel Filter

3. Install new O-rings (A) and (B) onto cover and vent cap³⁷.

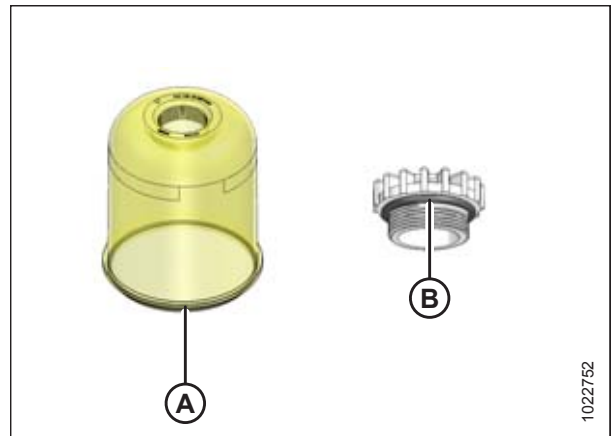

Figure 5.72: Cover and Vent Cap

37. Only if using greater than B5 fuel.

MAINTENANCE AND SERVICING

4. Install spring (A), cover (B), and collar (C). Hand tighten collar.
5. Add clean fuel to filter until level with top of filter element (D).

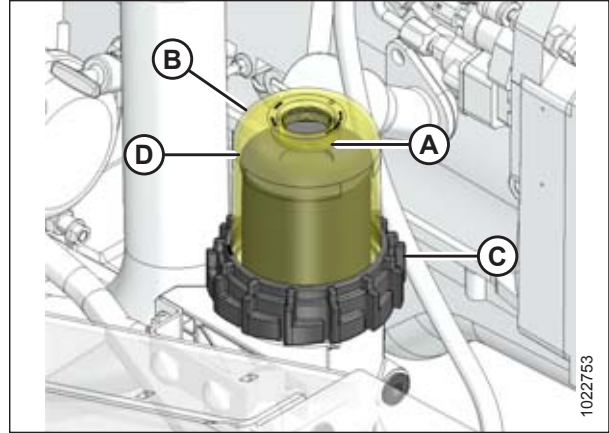

Figure 5.73: Primary Fuel Filter

6. Install vent cap (A). Hand tighten.
7. Reconnect water in fuel (WIF) sensor (not shown).
8. Start engine and run for 1 minute.
9. While engine is running, slowly open vent cap (A) and allow fuel level to drop to about 25 mm (1 in.) above collar (B).
10. Close vent cap (A) and hand tighten.

NOTE:

It is normal for fuel level to vary after initial start-up and during engine operation. Filter performance is not affected.

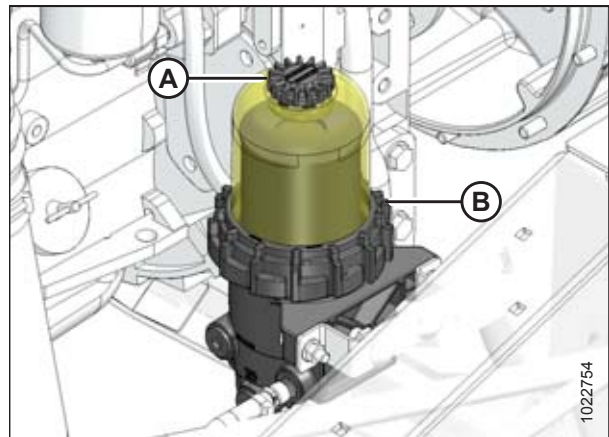

Figure 5.74: Primary Fuel Filter

11. Open valve (A) under fuel tank.

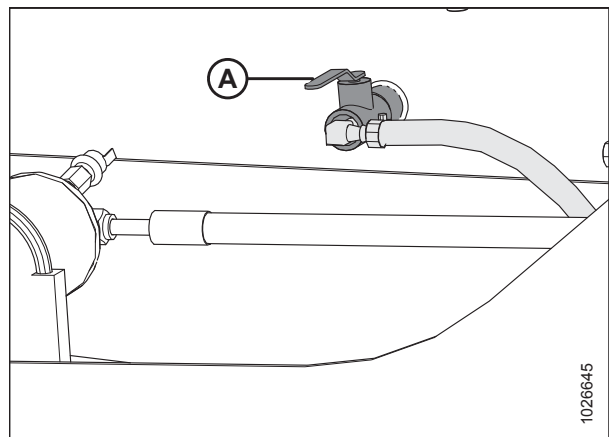

Figure 5.75: Fuel Shut-off valve

Removing Secondary Fuel Filter

⚠ WARNING

To avoid bodily injury or death from unexpected startup of the machine, always stop the engine and remove the key from the ignition before leaving the operator's seat for any reason.

1. Shut down the engine, and remove the key from the ignition.
2. Open the hood to the highest position. For instructions, refer to [5.2.3 Opening Hood – Highest Position, page 316](#).
3. Clean around secondary filter head (A).
4. Place a container under the filter to catch spilled fluid.
5. Remove filter (B) with a filter wrench.
6. Clean gasket mating surface.

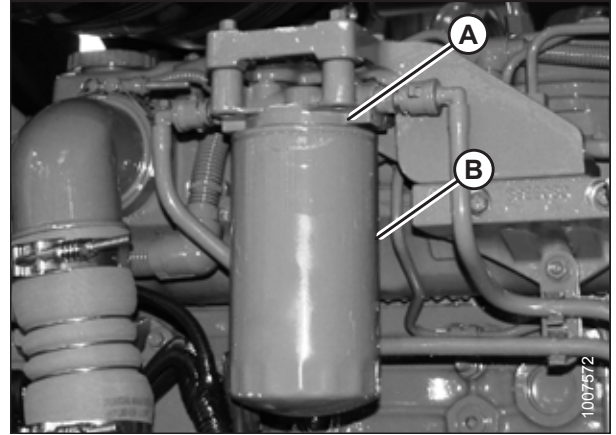

Figure 5.76: Secondary Fuel Filter

Installing Secondary Fuel Filter

For secondary fuel filter replacement part number, refer to [8.2.4 Filter Part Numbers, page 480](#).

1. Screw the new secondary filter (A) onto the filter mount until the gasket contacts the filter head.
2. Tighten the filter an additional 1/2 to 3/4 turn by hand.

IMPORTANT:

Do **NOT** use a filter wrench to install the filter. Overtightening can damage the gasket and filter.

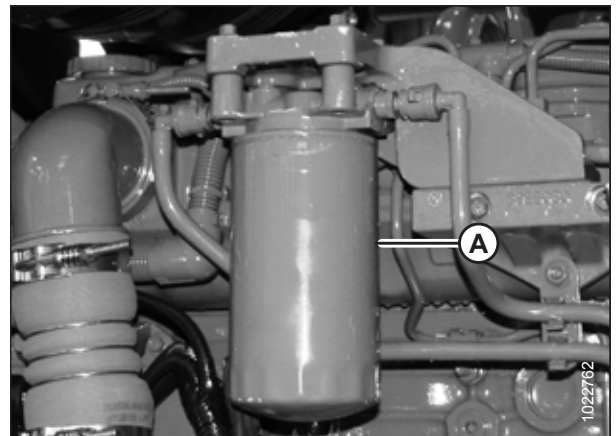

Figure 5.77: Secondary Fuel Filter

MAINTENANCE AND SERVICING

3. Open fuel valve (A) under fuel tank.
4. Prime the fuel system. Refer to *Priming Fuel System*, page 363.

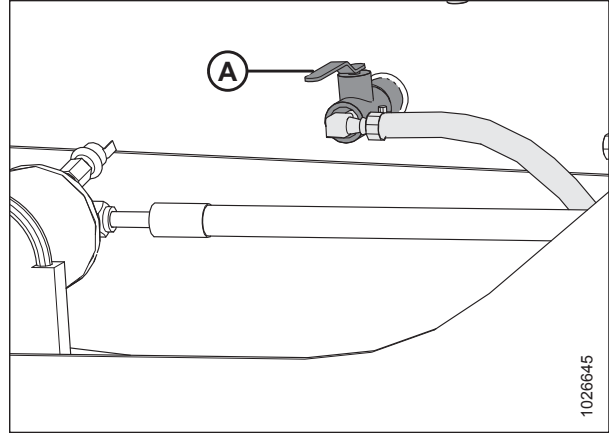

Figure 5.78: Fuel Shut-off Valve

Draining Fuel Tank

Draining the fuel tank is necessary to remove old or contaminated fuel.



WARNING

- To avoid personal injury or death from explosion or fire, do NOT smoke or allow flame or sparks near fuel tank when refueling.
- NEVER refuel the windrower when the engine is hot or running.
- To avoid electric discharge and the risk of a fire or explosion, ensure that the fuel delivery system is properly bonded and grounded. A bonded fuel delivery system has an electrically conductive and unbroken connection between all components of the fuel delivery system (fuel supply tank, transfer pump, transfer hose, nozzle, and others). A wire connection from the fuel delivery system to the machine chassis will equalize the static electric potential between the two machines, further reducing the chance of a static electric discharge. A properly grounded fuel delivery system has an electrically conductive connection from the fuel delivery system tank to earth ground to allow static and electrical charge dissipation.



WARNING

To avoid bodily injury or death from unexpected startup of the machine, always stop the engine and remove the key from the ignition before leaving the operator's seat for any reason.

1. Shut down the engine, and remove the key from the ignition.
2. Open the hood to the lower position. For instructions, refer to *5.2.1 Opening Hood – Lower Position*, page 314.

MAINTENANCE AND SERVICING

3. Close fuel supply valve (A) located on the bottom of the fuel tank.

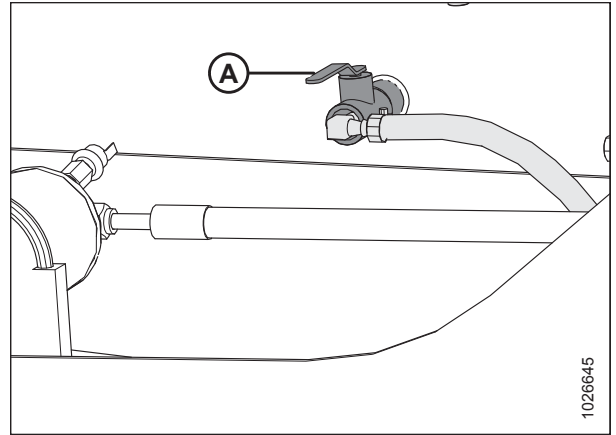

Figure 5.79: Fuel Shut-off Valve

4. Place a 20 liter (5 US gallon) drain pan under the fuel supply hose (A) at the primary filter.
5. Loosen clamp (B) and pull fuel supply hose (A) off fitting.

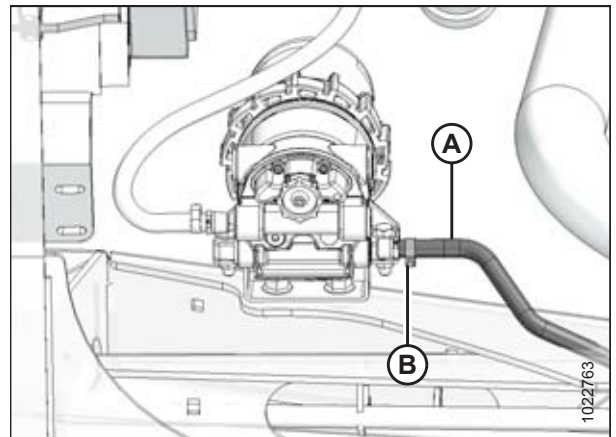

Figure 5.80: Fuel System

6. Route hose to drain pan and open valve (A) to drain tank.

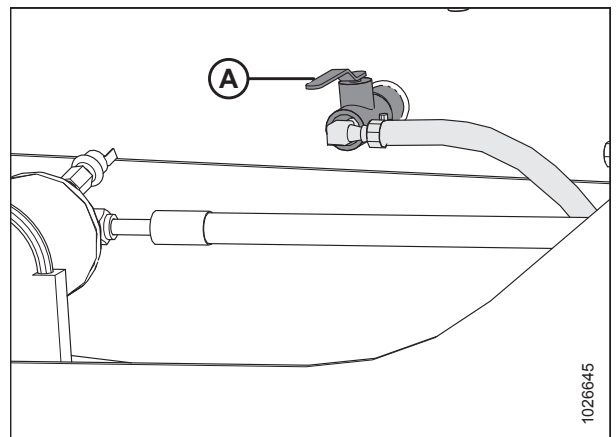

Figure 5.81: Bottom of Fuel Tank

MAINTENANCE AND SERVICING

7. Add some clean fuel to the tank to flush out any remaining contaminants.
8. Reattach fuel supply hose (A) to fitting. Install clamp (B) and tighten.

NOTE:

Do **NOT** refill the fuel tank if performing additional maintenance on fuel system. Refill it once work is completed. Refer to *Filling the Fuel Tank*, page 166.

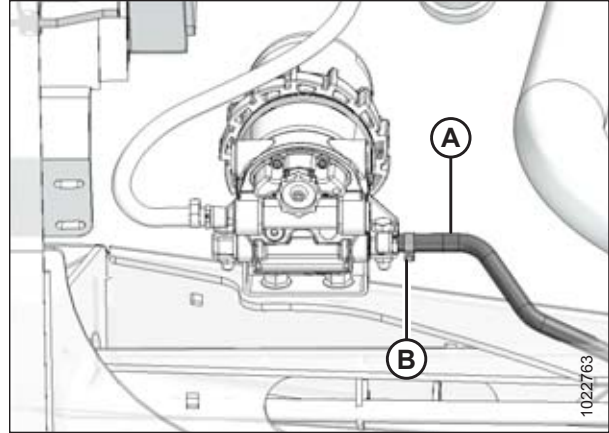

Figure 5.82: Fuel System

Fuel/Water Separator

A fuel/water separator is incorporated into the primary fuel filter. The separator is equipped with a drain and a sensor that triggers a warning on the cab display module (CDM) if water is detected in the fuel. Drain the water and sediment from the separator daily or at any time the CDM water in fuel (WIF) light illuminates.

To remove water from the fuel system, refer to *Removing Water from Fuel System*, page 362.

Removing Water from Fuel System

WARNING

To avoid bodily injury or death from unexpected startup of the machine, always stop the engine and remove the key from the ignition before leaving the operator's seat for any reason.

1. Shut down the engine, and remove the key from the ignition.
2. Open the hood to the lower position. For instructions, refer to *5.2.1 Opening Hood – Lower Position*, page 314.
3. Place a container under filter (A) to catch spilled fluid.
4. Turn drain valve (B) by hand 1 1/2 to 2 turns counterclockwise until fluid drains out of the filter.
5. Drain the filter sump of water and sediment until clear fuel is visible.
6. Turn the valve clockwise to close the drain.
7. Dispose of fluid safely.
8. Close the hood. Refer to *5.2.2 Closing Hood – Lower Position*, page 315.

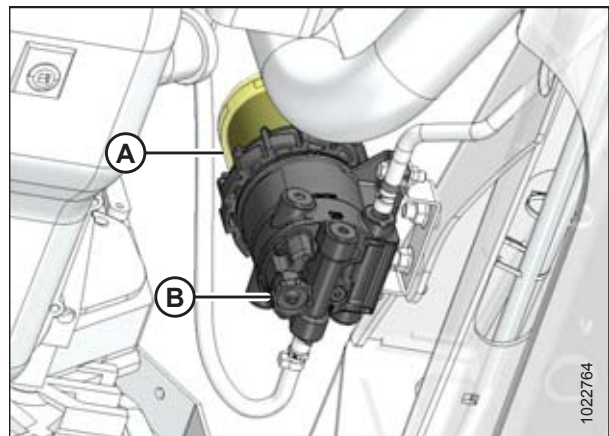

Figure 5.83: Primary Fuel Filter

System Priming

Controlled venting of air is provided at the injection pump through the fuel drain manifold. Small amounts of air, introduced by changing filters or injection pump supply line, will be vented automatically if the fuel filters are changed in accordance with instructions.

IMPORTANT:

Bleeding the fuel system is **NOT** recommended or required. Manual priming will be required if:

- Fuel filter is replaced
- Injection pump is replaced
- High-pressure fuel lines are replaced
- Engine is run until fuel tank is empty

Priming Fuel System

To prime the fuel system, follow these steps:

⚠ WARNING

To avoid bodily injury or death from unexpected startup of the machine, always stop the engine and remove the key from the ignition before leaving the operator’s seat for any reason.

⚠ WARNING

The fuel pump high-pressure fuel lines and fuel rail contain extremely high pressure fuel. Never loosen any fittings. Personal injury and property damage can result.

1. Shut down the engine, and remove the key from the ignition.
2. Open the hood to the lower position. For instructions, refer to *5.2.1 Opening Hood – Lower Position, page 314*.
3. Ensure drain valve (A) at base of filter is closed.
4. Remove vent cap (B) and fill bowl (C) with clean fuel.
5. Reinstall vent cap (B) and hand tighten.
6. Start engine and wait until lubrication system reaches normal operating pressure, then increase engine rpm to high idle for 1 to 2 minutes.
7. After air is purged, loosen vent cap (B) until fuel level lowers to just above collar (D), then hand tighten vent cap (B).

NOTE:

The bowl will not fill completely during engine operation but will gradually fill over time. The fuel level will rise as the filter becomes plugged.

8. Close the hood. Refer to *5.2.2 Closing Hood – Lower Position, page 315*.

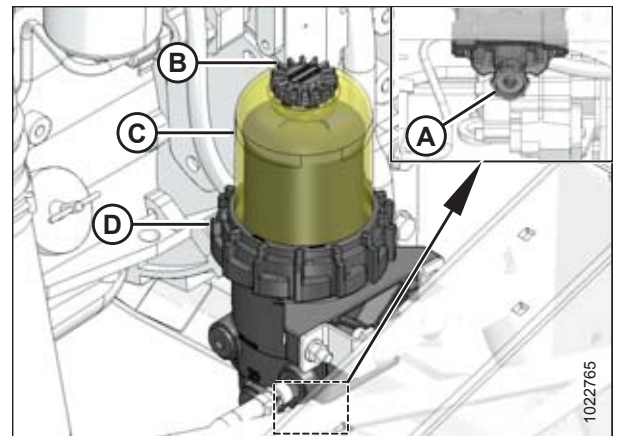

Figure 5.84: Primary Fuel Filter

5.8.6 Engine Cooling System

The engine cooling system is designed to maintain the engine operating temperature within the recommended operating range.

NOTE:

Antifreeze is essential in any climate. It broadens the operating temperature range by lowering the coolant freezing point and by raising its boiling point. Antifreeze also contains rust inhibitors and other additives to prolong engine life.

IMPORTANT:

If antifreeze strength is not adequate, do **NOT** drain cooling system to protect against freezing. The system may not drain completely, and damage from freezing could still result.

Refer to *8.2 Recommended Fuel, Fluids, and Lubricants, page 478* for detailed information.

Inspecting Radiator Cap

The radiator cap must fit tightly and the cap gasket must be in good condition to maintain the 97–124 kPa (14–18 psi) pressure in the cooling system. Check the condition of the cap every year when checking the engine coolant strength.

⚠ WARNING

To avoid bodily injury or death from unexpected startup of the machine, always stop the engine and remove the key from the ignition before leaving the operator's seat for any reason.

⚠ CAUTION

To avoid personal injury from hot coolant, do **NOT** turn radiator cap until engine cools.

1. Shut down the engine, and remove the key from the ignition.
2. Open the hood to the highest position. For instructions, refer to *5.2.3 Opening Hood – Highest Position, page 316*.
3. Move platform on the left cab-forward side of machine to open position. For instructions, refer to *5.3.1 Opening Platforms – Standard Position, page 318*.
4. Turn cap (A) counterclockwise to the first notch to relieve pressure before removing cap completely.
5. Turn cap (A) again and remove.
6. Check the gasket for cracks or deterioration and replace the cap if necessary.
7. Check that the spring in the cap moves freely.
8. Replace cap if spring is stuck.
9. Close the platform. For instructions, refer to *5.3.2 Closing Platforms – Standard Position, page 319*.
10. Close the hood from the highest position. For instructions, refer to *5.2.4 Closing Hood – Highest Position, page 317*.

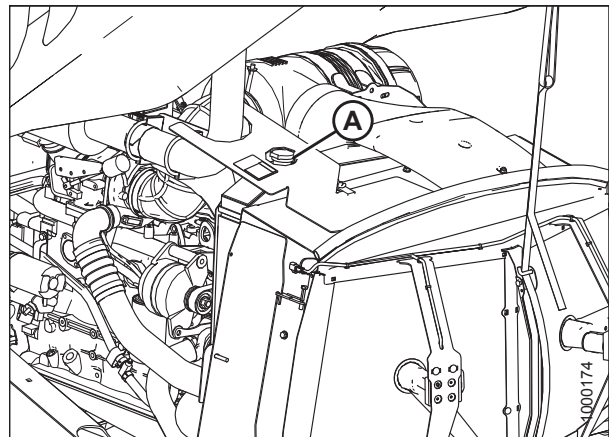

Figure 5.85: Engine Cooling System

Checking Engine Coolant Strength

Check the antifreeze in the radiator with a tester every year, preferably before off-season storage.

WARNING

To avoid bodily injury or death from unexpected startup of the machine, always stop the engine and remove the key from the ignition before leaving the operator's seat for any reason.

CAUTION

To avoid personal injury from hot coolant, do NOT turn radiator cap until engine cools.

1. Shut down the engine, and remove the key from the ignition.
2. Open the hood to the highest position. For instructions, refer to [5.2.3 Opening Hood – Highest Position, page 316](#).
3. Move platform on the left cab-forward side of machine to open position. For instructions, refer to [5.3.1 Opening Platforms – Standard Position, page 318](#).
4. Turn radiator cap (A) counterclockwise to the first notch to relieve pressure before removing cap completely.
5. Turn cap (A) again and remove.
6. Check the coolant in the radiator using an antifreeze tester. Tester should indicate protection to temperatures of -34°C (-30°F).
7. Inspect the radiator cap before reinstalling. Refer to [Inspecting Radiator Cap, page 364](#).
8. Reinstall radiator cap (A).
9. Close the platform. Refer to [5.3.2 Closing Platforms – Standard Position, page 319](#).
10. Close the hood. Refer to [5.2.4 Closing Hood – Highest Position, page 317](#).

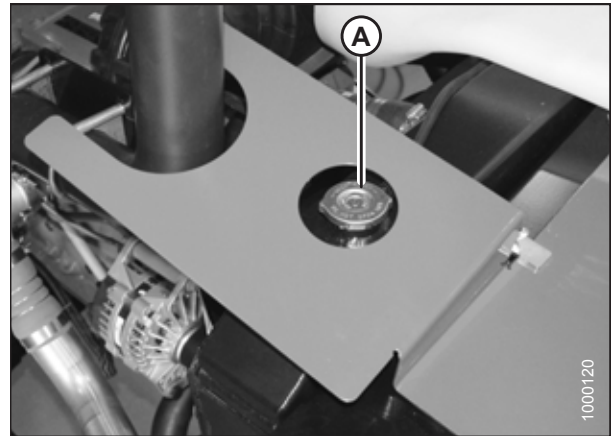

Figure 5.86: Engine Cooling System

Checking Coolant Level

WARNING

To avoid bodily injury or death from unexpected startup of the machine, always stop the engine and remove the key from the ignition before leaving the operator's seat for any reason.

Check coolant level in the coolant recovery tank daily.

1. Shut down the engine, and remove the key from the ignition.
2. Open the hood to the highest position. For instructions, refer to [5.2.3 Opening Hood – Highest Position, page 316](#).
3. Move platform on the left cab-forward side of machine to open position. For instructions, refer to [5.3.1 Opening Platforms – Standard Position, page 318](#).

MAINTENANCE AND SERVICING

4. Ensure coolant recovery tank (A) is one-half full. To add coolant, refer to [Adding Coolant, page 368](#).
5. Close the platform. Refer to [5.3.2 Closing Platforms – Standard Position, page 319](#).
6. Close the hood. Refer to [5.2.4 Closing Hood – Highest Position, page 317](#).

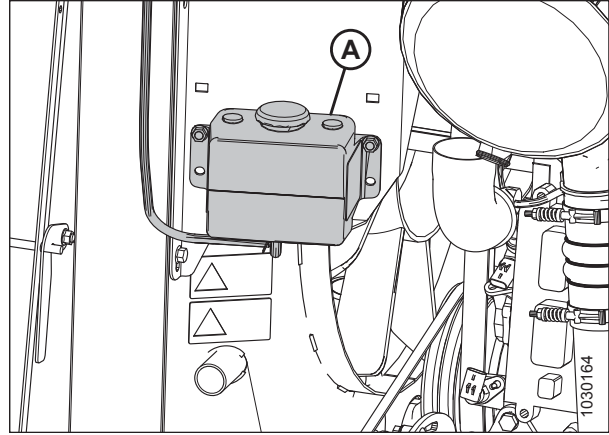

Figure 5.87: Engine Coolant Tank

Changing Coolant

Coolant should be drained and the system flushed and filled with new coolant every **2000 hours or 2 years**.

Refer to the following procedures:

- [Draining and Cleaning the Coolant Tank, page 366](#)
- [Adding Coolant, page 368](#)

Draining and Cleaning the Coolant Tank

WARNING

To avoid bodily injury or death from unexpected startup of the machine, always stop the engine and remove the key from the ignition before leaving the operator's seat for any reason.

CAUTION

To avoid personal injury from hot coolant, do NOT turn radiator cap until engine cools.

1. Shut down the engine, and remove the key from the ignition.
2. Open the hood to the highest position. For instructions, refer to [5.2.3 Opening Hood – Highest Position, page 316](#).
3. Move platform on the left cab-forward side of machine to open position. For instructions, refer to [5.3.1 Opening Platforms – Standard Position, page 318](#).
4. Turn radiator cap (A) to the first notch to relieve pressure before removing cap completely.

IMPORTANT:

Place a drain pan (about 30 liters [8 US gallons] capacity) under the engine and radiator, and use a deflector or hose to prevent coolant running onto frame.

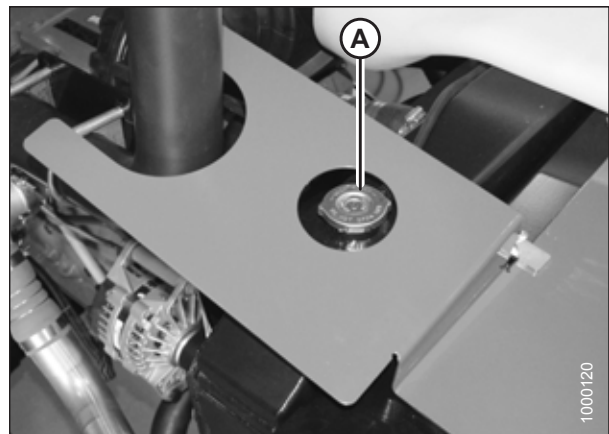

Figure 5.88: Radiator Cap

MAINTENANCE AND SERVICING

5. Remove the radiator cap and open radiator drain valve (A), located at the bottom of the engine side of the radiator lower tank.

NOTE:

Frame has been removed from illustration for clarity.

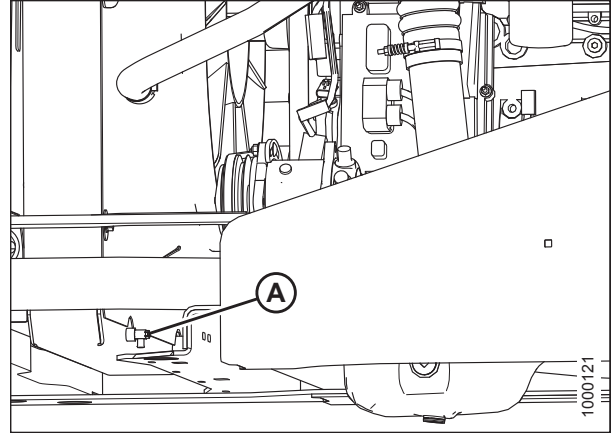

Figure 5.89: Radiator Drain Valve

6. Close the heater shut-off valve (A) and disconnect hose on heater side of valve.
7. Open valve to drain the block.
8. When system is drained, reattach hose on valve (A).

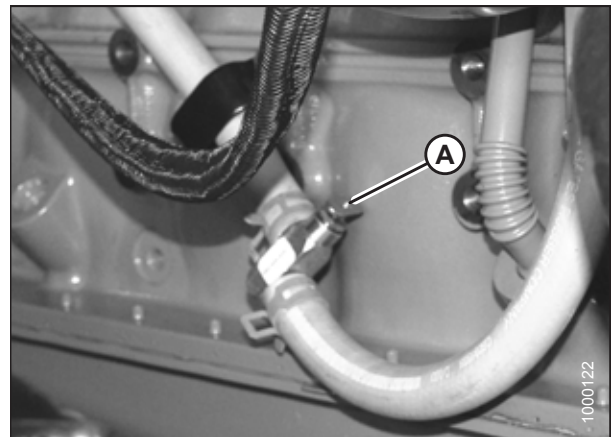

Figure 5.90: Heater Shut-Off Valve

9. Close radiator drain valve (A) at the bottom of the engine side of the radiator lower tank.

NOTE:

Frame has been removed from illustration for clarity.

10. Fill system with clean water through the radiator and replace the radiator cap.

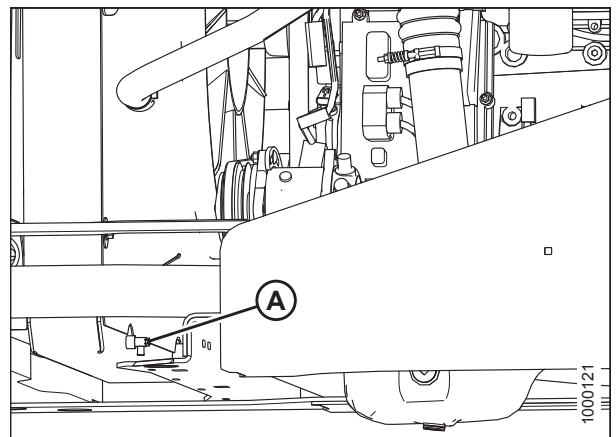

Figure 5.91: Radiator Drain Valve

MAINTENANCE AND SERVICING

11. Open heater shut-off valve (A).
12. Start engine and turn temperature control knob to HIGH. Run engine until normal operating temperature is reached.
13. Stop the engine and drain water out before rust or sediment settles. Repeat coolant removal procedure.
14. Close drain valves and fill system with a solution of clean water and a heavy duty radiator cleaner. Follow instructions provided with cleaner.
15. After using the cleaner solution, flush system with clean water again. Inspect radiator, hoses, and fittings for leaks.
16. Close drain valves and fill system. Refer to [Adding Coolant](#), page 368.
17. Replace cap (A) on coolant recovery tank (B).
18. Close the platform. Refer to [5.3.2 Closing Platforms – Standard Position](#), page 319.
19. Close the hood. Refer to [5.2.4 Closing Hood – Highest Position](#), page 317.

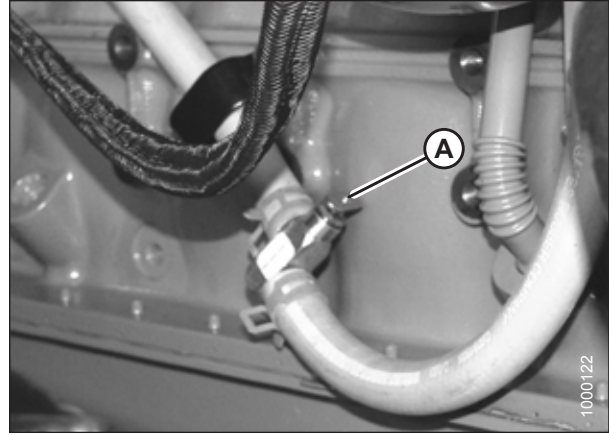

Figure 5.92: Heater Shut-Off Valve

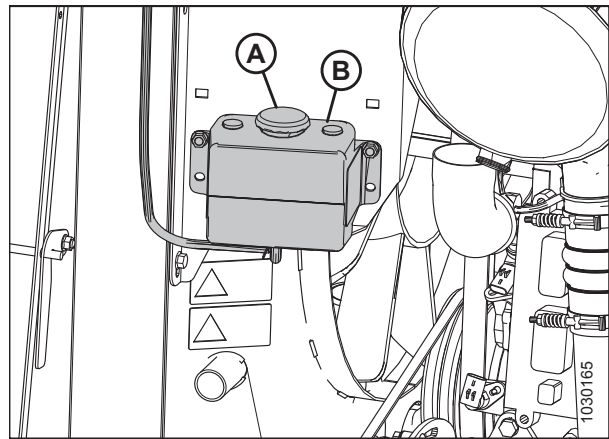

Figure 5.93: Coolant Recovery Tank

Adding Coolant

Check the coolant level in the coolant recovery tank daily. Add coolant if the tank is less than one-half full.

NOTE:

For coolant specifications, refer to the inside back cover.

⚠ WARNING

To avoid bodily injury or death from unexpected startup of the machine, always stop the engine and remove the key from the ignition before leaving the operator's seat for any reason.

⚠ CAUTION

To avoid personal injury from hot coolant, do NOT turn radiator cap until engine cools.

NOTE:

Do NOT add coolant directly into the radiator except when changing coolant.

MAINTENANCE AND SERVICING

To add coolant to the coolant recovery tank, follow these steps:

1. Shut down the engine, and remove the key from the ignition.
2. Open the hood to the highest position. For instructions, refer to [5.2.3 Opening Hood – Highest Position, page 316](#).
3. Move platform on the left cab-forward side of machine to open position. For instructions, refer to [5.3.1 Opening Platforms – Standard Position, page 318](#).
4. Remove cap (A) from coolant recovery tank (B).
5. Add coolant at a rate not exceeding 3 gallons per minute until the recovery tank is one-half full.

CAUTION

Before starting the machine, check to be sure all bystanders have cleared the area.

6. Start engine and run at high idle for approximately 20 minutes or until the engine temperature reaches 85°C (185°F).
7. Check the coolant level again and add coolant until the recovery tank is one-half full.
8. Replace cap (A).
9. Close the platform. Refer to [5.3.2 Closing Platforms – Standard Position, page 319](#).
10. Close the hood. Refer to [5.2.4 Closing Hood – Highest Position, page 317](#).

Maintaining Engine Cooling Box

The engine cooling box components should be cleaned daily—more frequently in severe dust conditions. Refer to the following list of procedures before attempting to service the engine cooling box components:

- [Opening Cooler Box Screen, page 370](#)
- [Charge Air Cooling, page 370](#)
- [Cleaning Screens and Coolers, page 371](#)
- [Cleaning Cooler Box Components, page 372](#)
- [Adjusting Screen Cleaner Rotor to Screen Clearance, page 374](#)
- [Closing Cooler Box Screen, page 374](#)

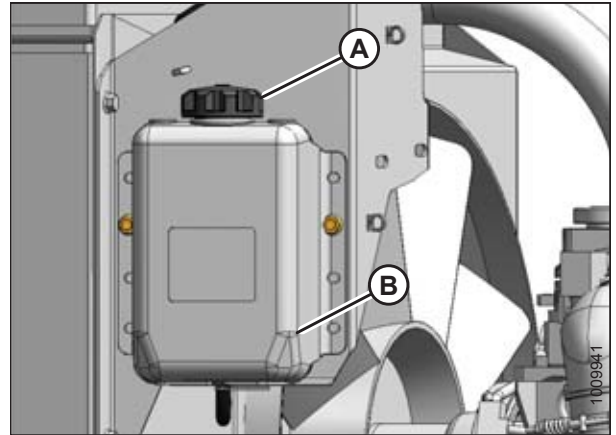

Figure 5.94: Coolant Recovery Tank

Opening Cooler Box Screen

1. Open the hood. Refer to [5.2.3 Opening Hood – Highest Position, page 316](#).
2. Push latch (A) and open screen assembly access door (B).
Secure with rod, stored inside screen door.

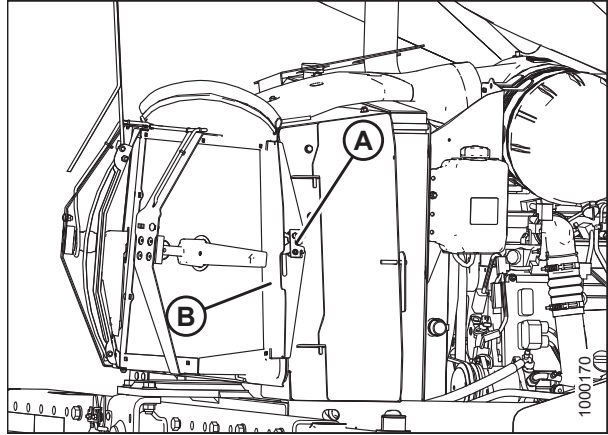

Figure 5.95: Engine Cooling System

Charge Air Cooling

Charge air is routed through a cooler that is located in the cooling box (A), prior to entering the engine intake. The cooler should be cleaned daily with compressed air. Refer to [Cleaning Screens and Coolers, page 371](#) and [Cleaning Cooler Box Components, page 372](#).

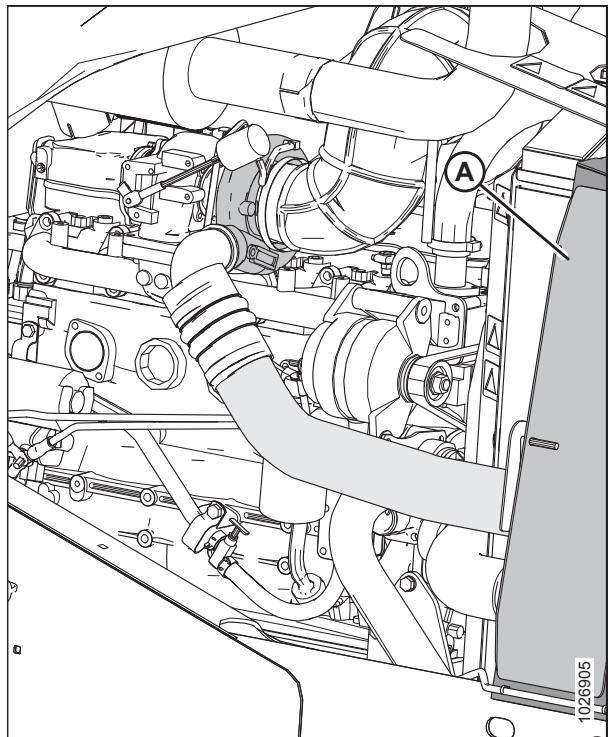

Figure 5.96: Engine Air Intake System

MAINTENANCE AND SERVICING

Cleaning Screens and Coolers

When the engine is running, two electrically-driven rotors and suction from the engine's cooling fan sweep and vacuum debris away from the cooling box screen. If the screen is not being cleaned, the rotors or ducts may be plugged. Follow these steps to clear plugged rotors:

NOTE:

The following procedure is performed on one side, procedure also applies to the other side.

1. Open the hood. Refer to [5.2.3 Opening Hood – Highest Position, page 316](#).
2. Remove nuts (B).
3. Pivot screen cleaner assembly (C) away from screen.
4. Blow out debris from cleaner duct (A) with compressed air.
5. If duct is plugged, open the cooler box screen. Refer to [Opening Cooler Box Screen, page 370](#).

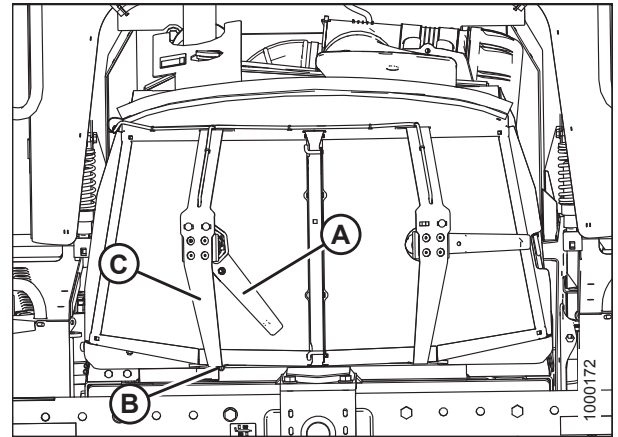

Figure 5.97: Screen Cleaner Assembly

6. Blow debris out of duct (A) with compressed air.
7. Clean screen with compressed air.

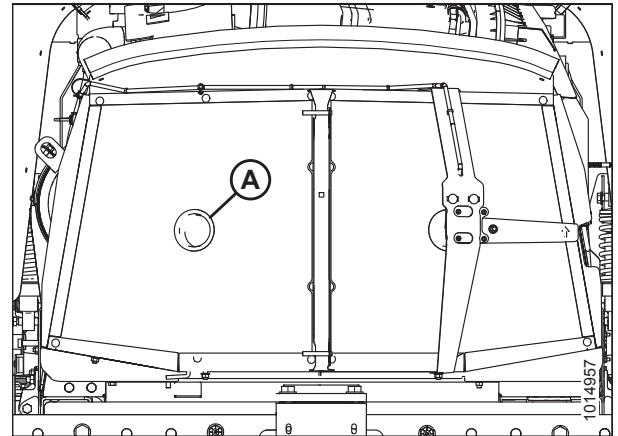

Figure 5.98: Cooler Box Screen

MAINTENANCE AND SERVICING

8. Move screen cleaner assembly (C) back into position and secure with bolts and nuts (B).
9. Check duct (A) clearance to screen. Refer to [Adjusting Screen Cleaner Rotor to Screen Clearance, page 374](#).
10. Close the cooler box screen. Refer to [Closing Cooler Box Screen, page 374](#).
11. Close the hood. Refer to [5.2.4 Closing Hood – Highest Position, page 317](#).

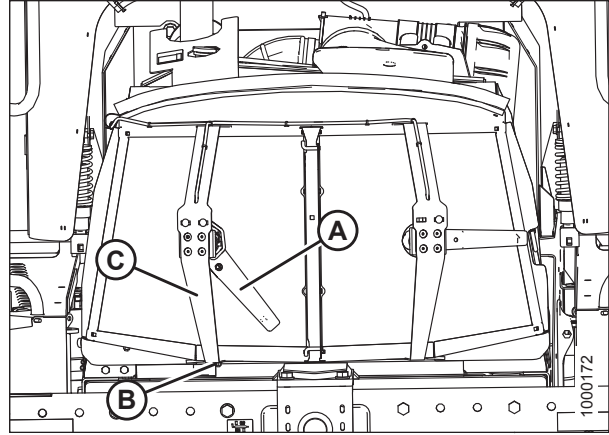

Figure 5.99: Screen Cleaner Assembly

Cleaning Cooler Box Components

The radiator and oil cooler should be cleaned daily with compressed air. More frequent cleaning may be necessary in severe conditions. The charge air cooler and air conditioning (A/C) condenser may also be cleaned at the same time.

To clean these components, proceed as follows:

1. Open cooler box screen. Refer to [Opening Cooler Box Screen, page 370](#).
2. Lift latch (A) and open right access door (B).

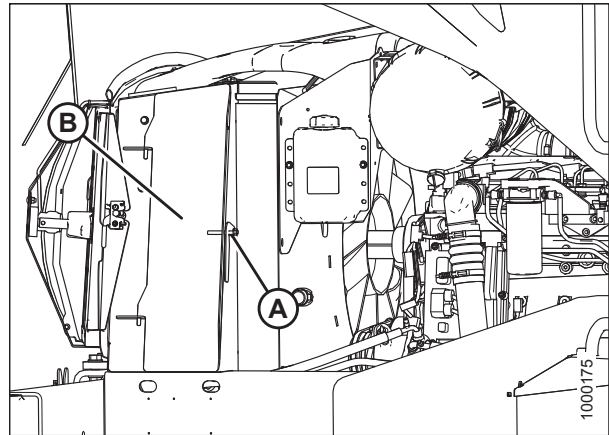

Figure 5.100: Right Cooler Access Door

3. Slide out the oil cooler / air conditioning (A/C) condenser assembly (A).

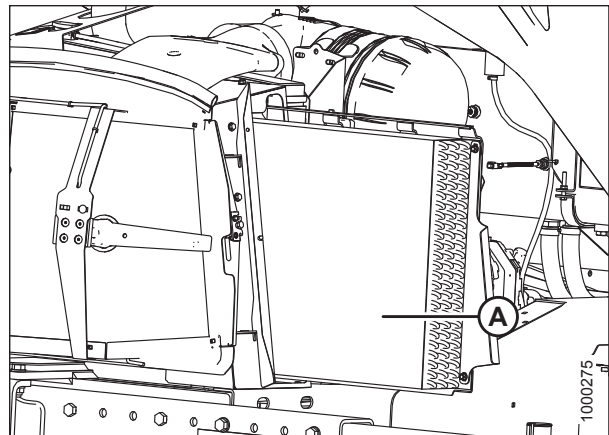

Figure 5.101: A/C Condenser Assembly

MAINTENANCE AND SERVICING

4. Lift latch (A) and open left access door (B).

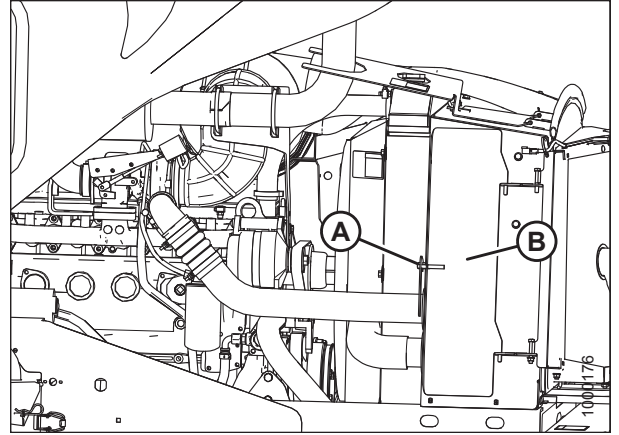

Figure 5.102: Left Cooler Access Door

5. Remove wing nut (A) and open access door (B) at top of cooling box.

NOTE:

Fins on coolers can be very easily bent which may interfere with its function. Exercise caution when cleaning.

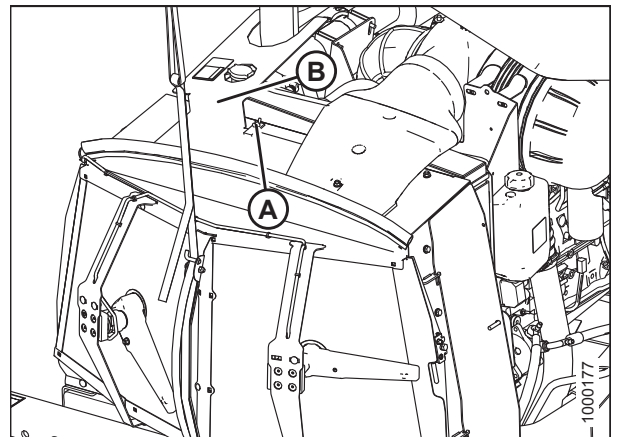

Figure 5.103: Cooling Box Access Door

6. Clean radiator (D) through access hole in cooling box with compressed air.
7. Clean oil cooler / air conditioning condenser (A), charge air cooler (E), cooling box (C), and fuel cooler (B) with compressed air.
8. Inspect all lines and coolers for evidence of leaks and damage.
9. Slide oil cooler / air conditioning condenser (A) back into cooling box (C).
10. Close side access door and lock with lever.
11. Close access door on top of the cooling box and secure with wing nut.
12. Close cooler box screen. Refer to [Closing Cooler Box Screen](#), page 374.

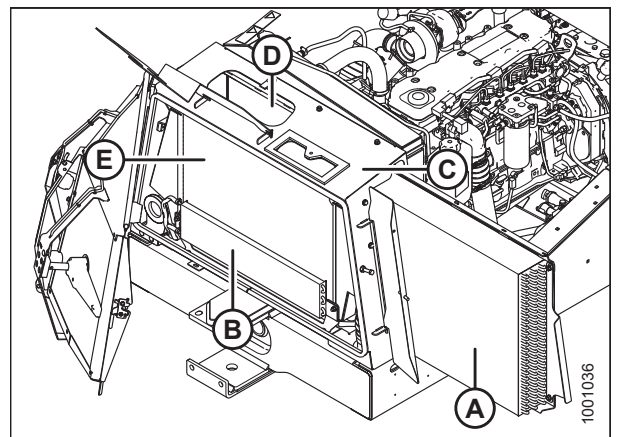

Figure 5.104: Engine Cooling System

Adjusting Screen Cleaner Rotor to Screen Clearance

The clearance between the trailing edge of the screen cleaner rotor and the screen should be 1–8 mm (0.039–0.314 in.) at all locations when rotating.

WARNING

To avoid bodily injury or death from unexpected startup of the machine, always stop the engine and remove the key from the ignition before leaving the operator's seat for any reason.

1. Shut down the engine, and remove the key from the ignition.
2. Open the hood to the lower position. For instructions, refer to [5.2.1 Opening Hood – Lower Position, page 314](#).

NOTE:

Screen cleaner rotors rotate counterclockwise and may touch the screen as long as they continue to rotate.

3. Loosen nut (B) on motor support (C).
4. Move the support in or out until duct (A) is 2–6 mm (0.079–0.236 in.) from the screen near the center.
5. Tighten nut (B).
6. Loosen two motor mount bolts (D).
7. Move motor/duct assembly (E) to obtain 1–8 mm (0.039–0.314 in.) gap to screen at full rotation of the rotor.
8. Tighten nuts (D) on the motor mount.
9. Close the hood. Refer to [5.2.2 Closing Hood – Lower Position, page 315](#).

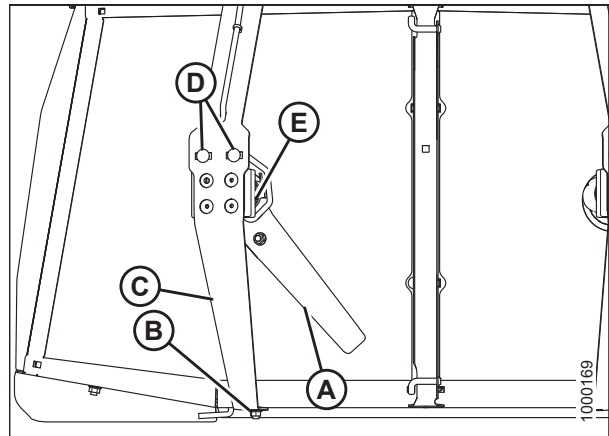

Figure 5.105: Screen Cleaner

Closing Cooler Box Screen

1. Unhook the support rod and store it in the screen door. Close screen access door (B) and engage latch (A).
2. Close the hood. Refer to [5.2.4 Closing Hood – Highest Position, page 317](#).

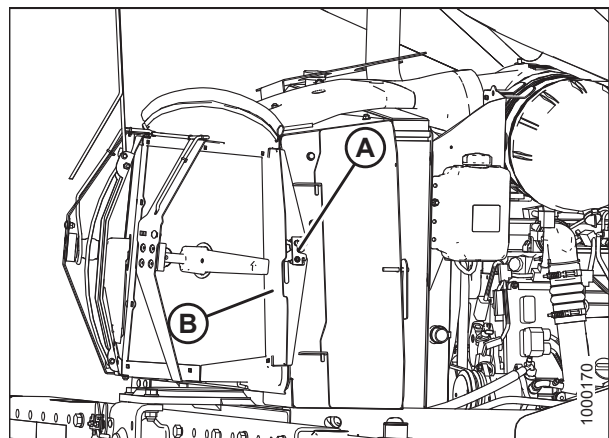

Figure 5.106: Engine Cooling System

5.8.7 Gearbox

Checking Lubricant Level and Adding Lubricant

CAUTION

Park on a flat, level surface with the header on the ground, the ground speed lever (GSL) in N-DETENT position, and the steering wheel in locked position (centered). Wait for the combine display module (CDM) to beep and display an “In Park” message to confirm the park brakes have engaged.

WARNING

To avoid bodily injury or death from unexpected startup of the machine, always stop the engine and remove the key from the ignition before leaving the operator’s seat for any reason.

Check the lubricant level every 50 hours as follows:

1. Park the windrower on level ground, shut down engine, and remove key.
2. Remove check plug (A). The lubricant should be visible through the hole or slightly running out.

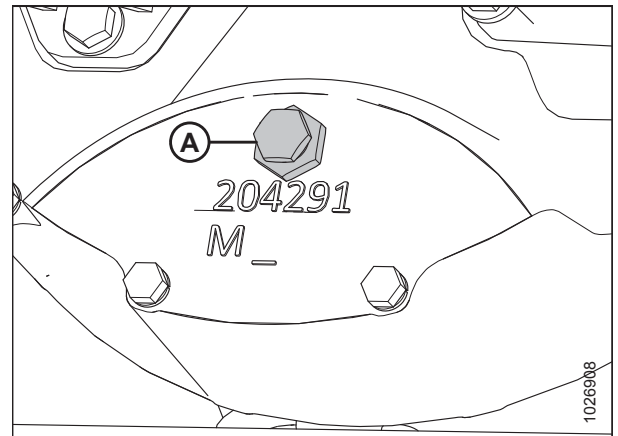

Figure 5.107: Gearbox Lubricant Check Plug

3. Add lubricant as follows:
 - a. Remove breather cap (A) and add lubricant until it runs out the check port. If refilling, add approximately 2.1 liters (2.2 US quarts).
 - b. Replace check plug and breather cap and tighten.
 - c. Operate the engine at low idle and check for leaks at the check plug and drain plug.



Figure 5.108: Gearbox Breather Cap

Changing Lubricant

Change gearbox lubricant after the first 50 hours, and then every 500 hours as follows:

CAUTION

Park on a flat, level surface with the header on the ground, the ground speed lever in N-DETENT position, and the steering wheel in locked position (centered). Wait for the CDM to beep and display an “In Park” message to confirm the park brakes have engaged.

WARNING

To avoid bodily injury or death from unexpected startup of the machine, always stop the engine and remove the key from the ignition before leaving the operator’s seat for any reason.

NOTE:

The engine should be warm when changing the oil.

1. Shut down the engine, and remove the key from the ignition.
2. Place a 4 liter (1 US gallon) drain pan under the gearbox.
3. Remove drain plug (B) and let the oil drain completely.
4. Install drain plug (B) and remove check plug (A).

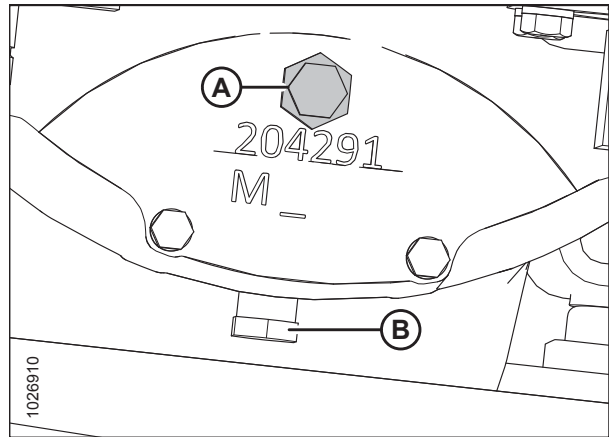

Figure 5.109: Gearbox Lubricant Drain Plug

5. Add lubricant as follows:
 - a. Remove breather cap (A) and add lubricant until it runs out the check port. If refilling, add approximately 2.1 liters (2.2 US quarts).
 - b. Replace check plug and breather cap and tighten.
 - c. Operate the engine at low idle and check for leaks at the check plug and drain plug.

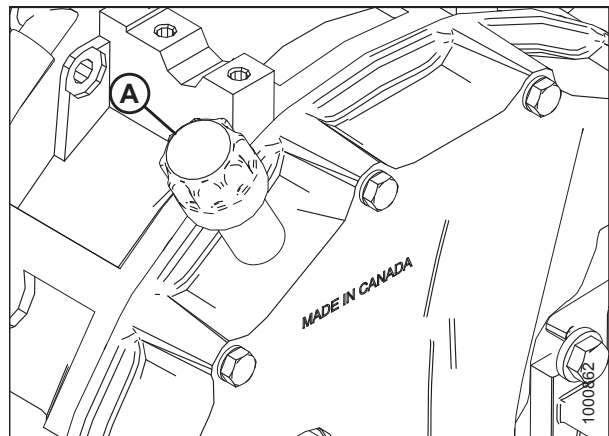

Figure 5.110: Gearbox Breather Cap

5.8.8 Exhaust System

CAUTION

Engine exhaust stack may be hot. To avoid burns, do NOT touch exhaust canister when engine is running. Allow sufficient cooling time after shut-down.

The exhaust system requires no regular maintenance, but it should be inspected periodically as follows:

1. Open the hood to its highest position. For instructions, refer to [5.2.3 Opening Hood – Highest Position, page 316](#).
2. Inspect the area around clamps (A) for breakage, cracks, and rust-through. In addition to excess noise, a leaky exhaust system may allow exhaust gases to escape to the cab.
3. Check tubing for dents or crushed areas. Dents or crushed portions of any tubing create exhaust flow restriction and increase back pressure significantly. Even relatively small dents will cause decreased fuel economy and increased turbo wear. If dents are relatively large, increased bearing and cylinder wear will occur due to increased exhaust temperature.
4. Make sure the exhaust system is secured to eliminate vibration. Brackets (B) should fit securely to muffler (C) and to the engine.

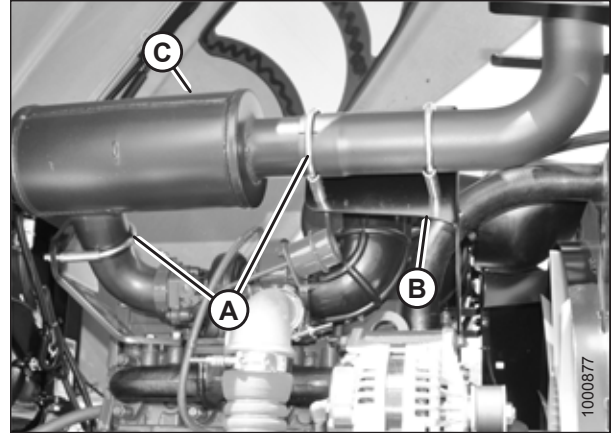

Figure 5.111: Exhaust System

IMPORTANT:

Do NOT change muffler type, piping sizes, or exhaust configuration. See your Dealer for proper replacement parts.

5.8.9 Belts

Tensioning Alternator/Fan Belt

The alternator, water pump, and fan belt are automatically tightened. Manual adjustment is **NOT** required.

Replacing Fan Belt

WARNING

To avoid bodily injury or death from unexpected startup of the machine, always stop the engine and remove the key from the ignition before leaving the operator's seat for any reason.

1. Shut down the engine and remove the key.
2. Open the left cab-forward platform. Refer to [5.3.1 Opening Platforms – Standard Position, page 318](#).
3. Open the hood. Refer to [5.2.1 Opening Hood – Lower Position, page 314](#).

MAINTENANCE AND SERVICING

- Loosen compressor mounting hardware (B) and push compressor towards engine to release tension.
- Remove belt (A) from compressor.

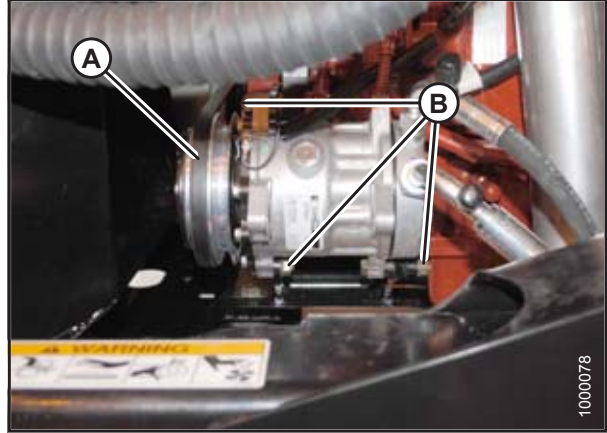

Figure 5.112: A/C Compressor

- Insert the drive end of a 1/2 in. drive ratchet wrench into belt tensioner (B).
- Rotate tensioner counterclockwise until fan belt (A) can be slipped off pulley (C). Release tensioner and remove wrench.
- Remove belt in order 1–2–3 as shown. Route fan belt around fan and remove belt.
- Install new belt (A) around fan and onto pulleys in order 3–2–1 as shown.
- Insert the drive end of a 1/2 in. drive ratchet wrench into belt tensioner (B).
- Rotate tensioner counterclockwise until belt (A) can be slipped onto pulley (C). Release tensioner and remove wrench.
- Check that belt is properly seated in all pulley grooves.
- Reinstall compressor belt (A).
- Pry compressor away from engine so that a force of 35–55 N (8–12 lbf) deflects belt (A) 5 mm (3/16 in.) at mid-span.
- Tighten compressor mounting hardware (B).
- Recheck tension and adjust as required.
- Close the hood. Refer to [5.2.2 Closing Hood – Lower Position](#), page 315.
- Close the platform. Refer to [5.3.2 Closing Platforms – Standard Position](#), page 319.

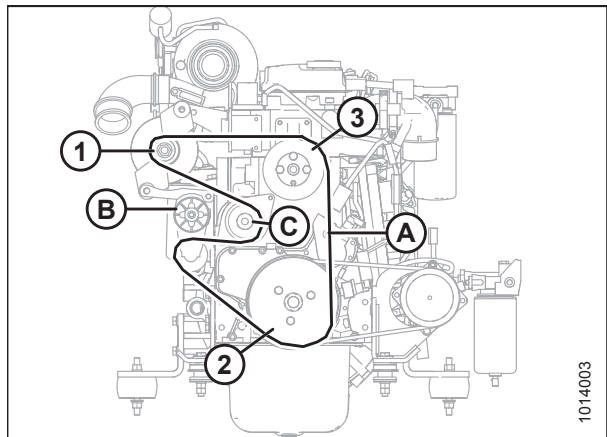

Figure 5.113: Engine Belts

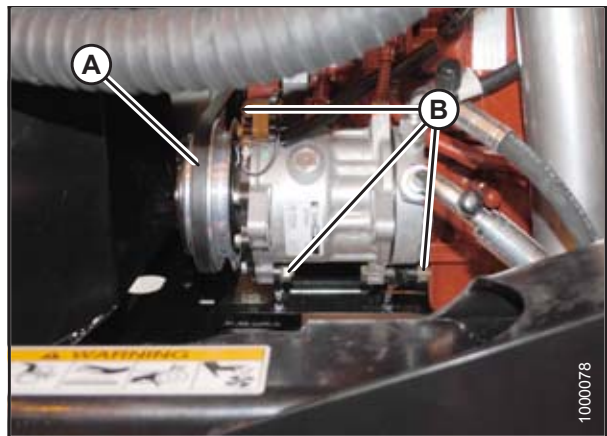

Figure 5.114: A/C Compressor

Tensioning Air Conditioner Compressor Belt

⚠ WARNING

To avoid bodily injury or death from unexpected startup of the machine, always stop the engine and remove the key from the ignition before leaving the operator's seat for any reason.

1. Shut down the engine, and remove the key from the ignition.
2. Open the hood to the lower position. For instructions, refer to [5.2.1 Opening Hood – Lower Position, page 314](#).
3. Loosen compressor mounting hardware (B).
4. Pry compressor away from engine so that a force of 35–55 N (8–12 lbf) deflects belt (A) 5 mm (3/16 in.) at mid-span.
5. Tighten compressor mounting hardware (B).
6. Recheck tension and adjust as required.
7. Close the hood from the lower position. For instructions, refer to [5.2.2 Closing Hood – Lower Position, page 315](#).

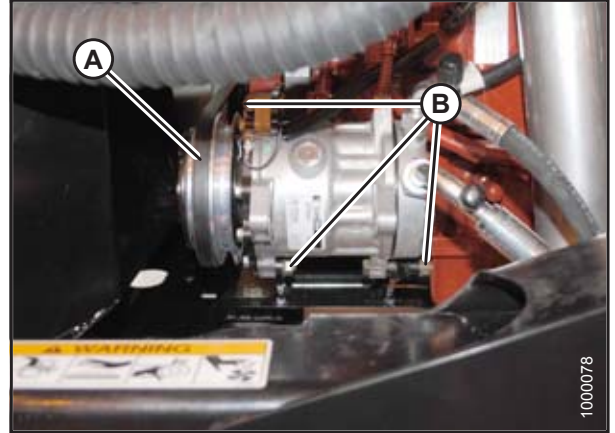

Figure 5.115: A/C Compressor

Replacing Air Conditioner Compressor Belt

⚠ WARNING

To avoid bodily injury or death from unexpected startup of the machine, always stop the engine and remove the key from the ignition before leaving the operator's seat for any reason.

1. Shut down the engine, and remove the key from the ignition.
2. Open the hood to the lower position. For instructions, refer to [5.2.1 Opening Hood – Lower Position, page 314](#).
3. Loosen compressor mounting hardware (B) and push compressor towards engine to release tension.
4. Remove belt (A) from compressor.
5. Install new compressor belt (A).
6. Pry compressor away from engine so that a force of 35–55 N (8–12 lbf) deflects belt (A) 5 mm (3/16 in.) at mid-span.
7. Tighten compressor mounting hardware (B).
8. Recheck tension and adjust as required.
9. Close the hood. Refer to [5.2.2 Closing Hood – Lower Position, page 315](#).

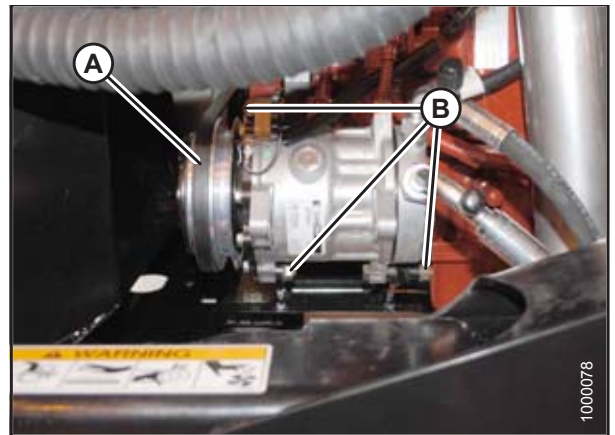

Figure 5.116: A/C Compressor

5.8.10 Engine Speed

The maximum and idle engine speeds are factory set.

Refer to *2.2 Specifications, page 28* for detailed information. If specified speeds cannot be maintained, see your MacDon Dealer.

IMPORTANT:

Do **NOT** remove any seals from injector pump. Removal of seals will void the engine warranty.

Refer to *Engine Intermediate Speed Control, page 164* for additional information about engine speed.

Throttle Adjustment

The engine speed is controlled by a throttle lever connected to an electronic sensor inside the console.

The throttle lever in the cab should move the throttle sensor the full range between slow speed stop and full rpm stop without contacting the console at either position.

If the throttle lever is contacting the console and interferes with specified engine speeds, the sensor position may need adjustment. See your MacDon Dealer.

5.9 Electrical System

5.9.1 Preventing Electrical System Damage

To prevent electrical system damage, take the following precautions:

- Carefully observe polarity when attaching booster battery.
- Do **NOT** short across battery or alternator terminals, or allow battery positive (+) cable or alternator wire to become grounded.
- Be sure alternator connections are correct before cables are connected to battery.
- When welding on any part of the machine, disconnect battery cables and alternator wire. Refer to [1.8 Welding Precautions, page 9](#).
- Always disconnect battery ground cable when working with the alternator or regulator.
- Do **NOT** attempt to polarize alternator or regulator.
- If wires are disconnected from the alternator, ensure that terminals (A) and (B) are connected properly.
- Do **NOT** ground the alternator field terminal or field.
- Do **NOT** connect or disconnect alternator or regulator wires with battery connected or alternator operating.
- Always disconnect cables from the battery when using a charger to charge battery in windrower.
- Ensure all cables are securely connected before operating engine.
- To avoid damage to circuit boards by static electricity, disconnect negative battery terminal when replacing electronic control modules. Additionally, when handling electronic control modules, avoid touching the connector pins directly.

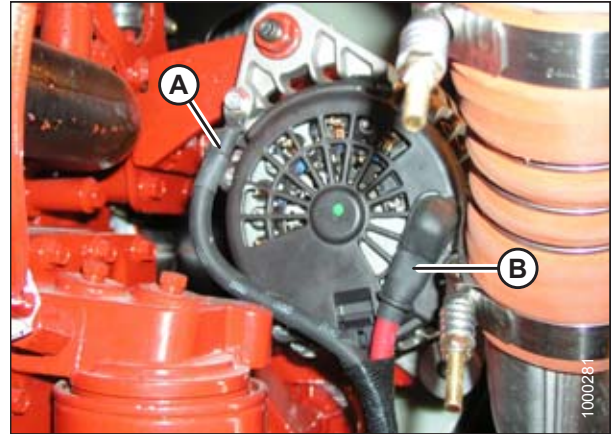

Figure 5.117: Alternator

A - Negative Terminal

B - Positive Terminal

5.9.2 Battery

Maintaining Batteries

CAUTION

Do **NOT** attempt to service battery unless you have the proper equipment and experience to perform the job. Have it done by a qualified Dealer.

- Check battery charge once a year, or more often if operating in cold weather. Hydrometer readings should be 1.260 to 1.300. Readings below 1.250 indicate charging is required. Refer to *Charging the Batteries, page 383*. Add electrolyte if necessary. Refer to *Adding Electrolyte to the Batteries, page 386*.
- Keep batteries clean by wiping with a damp cloth.
- Keep all connections clean and tight; remove any corrosion and wash terminals with a solution of baking soda and water. A light coating of grease on terminals (after cables are attached) will reduce corrosion.
- To prolong battery life, store batteries in a cool, dry area, in an upright position, fully charged at -7° to $+26^{\circ}\text{C}$ ($+20^{\circ}$ to $+80^{\circ}\text{F}$).
- Do **NOT** stack batteries on top of each other unless they are in cartons.
- Test wet batteries every 4–6 months and recharge if necessary.

Battery Main Disconnect Switch

A battery main disconnect switch (A) is located on the right cab-forward side frame rail, just behind the batteries. It can be easily accessed by moving the maintenance platform.

Ensure the switch is in the POWER OFF position when servicing electrical components and to prevent loss of battery charge when the windrower will not be used for periods longer than 1 week.

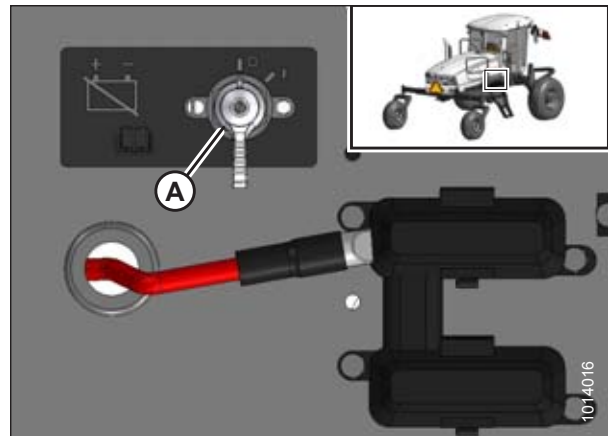

Figure 5.118: Batteries

Charging the Batteries

CAUTION

- Ventilate the area where batteries are being charged.
- Do NOT charge a frozen battery. Warm to 16°C (60°F) before charging.
- Do NOT connect or disconnect live circuits. To prevent sparks, turn off charger and connect positive cable first. PROTECT YOUR EYES.
- If charging battery in windrower, disconnect POSITIVE battery cable before connecting charger cable, then connect ground cable last, away from battery.
- Stop or cut back charging rate if battery feels hot, or is venting electrolyte. Battery temperature must NOT exceed 52°C (125°F).
- The maximum charge rate in amperes should be NO MORE than 1/3 of the battery’s reserve capacity minute rating. If the terminal voltage exceeds 16.0 volts while charging, reduce the charge rate.
- Continue charging and reduce the rate as needed until a 2-hour period results in no increase in voltage or decrease in current.

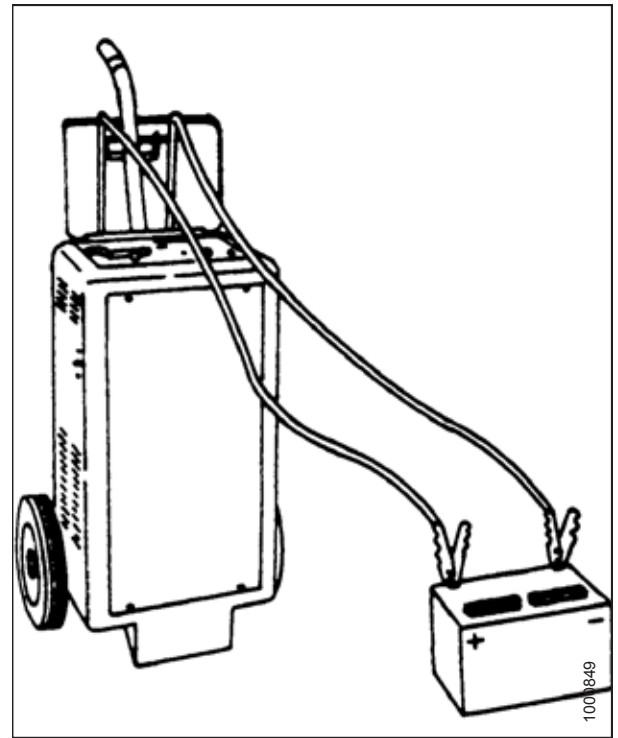

Figure 5.119: Charging Battery

Table 5.1 Voltage Chart

Voltage	State of Charge (%)	Approximate Battery Charging Time ³⁸ to Full Charge at 27°C/80°F (Minutes)			
		Maximum Rate at (Amps)			
Standard Battery		50	30	20	10
12 Volts					
12.6	100	— FULL CHARGE —			
12.4	75	20	35	48	90
12.2	50	45	75	95	180
12.0	25	65	115	145	280
11.8	0	85	150	195	370

WARNING

- Gel and Absorbed Glass Mat (AGM) batteries require a voltage-limited charger. Charging a Gel or AGM battery on a typical shop charger—even one time—may greatly shorten its life.
- If the electrolyte is accessible, verify that plates are covered before beginning to charge. At the end of charge, add distilled water as needed to bring levels to the proper height. If water is added, charge for an additional 30 minutes to mix. If electrolyte levels are low, but battery is not accessible, remove battery from service.

38. Charging time depends upon battery capacity, condition, age, temperature, and efficiency of charger.

CAUTION

Follow all instructions and precautions furnished by the battery charger manufacturer, including the following:

- Charge at recommended rates and times.
- Turn off charger prior to hook up to avoid dangerous sparks. Wear proper eye protection.
- Reduce charge rate if the terminal voltage is higher than 16.0 volts while charging. The maximum charge rate in amperes should NOT exceed 1/3 of the battery's reserve capacity minute rating.
- Continue charging if there is no change in voltage or current for a period of 2 hours and reduce the rate as needed.
- If the battery case gets hot during charging or spews large amount of gasses, temporarily stop charging.

IMPORTANT:

NEVER overcharge batteries. Excessive charging will shorten battery life.

To charge battery, follow these steps:

WARNING

To avoid bodily injury or death from unexpected startup of the machine, always stop the engine and remove the key from the ignition before leaving the operator's seat for any reason.

1. Shut down the engine, and remove the key from the ignition.
2. Move platform on right cab-forward side of machine to open position to allow access to the batteries. For instructions, refer to [5.3.1 Opening Platforms – Standard Position, page 318](#).
3. Remove red plastic covers (A) from positive cable clamps.
4. Remove black plastic covers (B) from negative terminals.
5. If charging battery in windrower, disconnect **positive** battery cable (A), then connect charger cable to positive post. Connect charger ground cable to the engine block last, away from battery.
6. Charge batteries in accordance with charger manufacturer's instructions.
7. Close platform. For instructions, refer to [5.3.2 Closing Platforms – Standard Position, page 319](#).

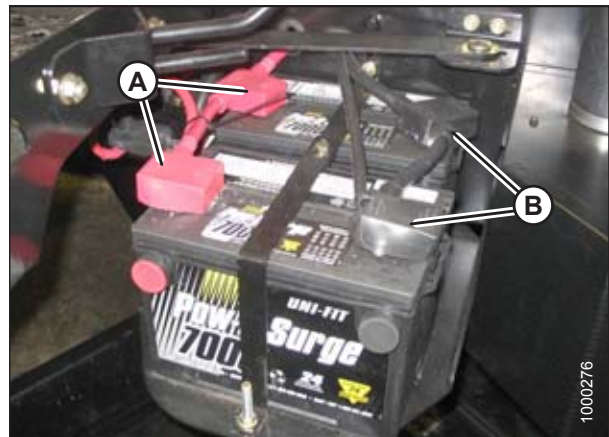

Figure 5.120: Battery Terminal Location

Boosting the Batteries

A 12-volt battery can be connected in parallel (+ to +) with the windrower battery. Use heavy-duty battery cables.

CAUTION

- Gas given off by batteries is explosive. Keep sparks and flames away from batteries.
- Make last connection and first disconnection at the point furthest away from the batteries.
- Wear protective eyewear when using a booster battery.
- Be sure everyone is clear of machine when starting engine. Start engine from operator's station only.

1. Open the hood. For instructions, refer to *5.2.1 Opening Hood – Lower Position, page 314*.
2. Remove red rubber cover from boost post (A) on windrower frame.
3. Attach one end of battery cable to positive (+) terminal of booster battery, and other end to positive boost post (A) on windrower frame.
4. Attach second cable to negative (-) terminal of booster battery, and then to ground post (B) on windrower frame.
5. Turn ignition switch in cab as with normal start up.
6. After engine starts, disconnect cable from windrower ground first, and then disconnect the other cables.
7. Replace rubber cover on boost post (A).
8. Close the hood. For instructions, refer to *5.2.2 Closing Hood – Lower Position, page 315*.

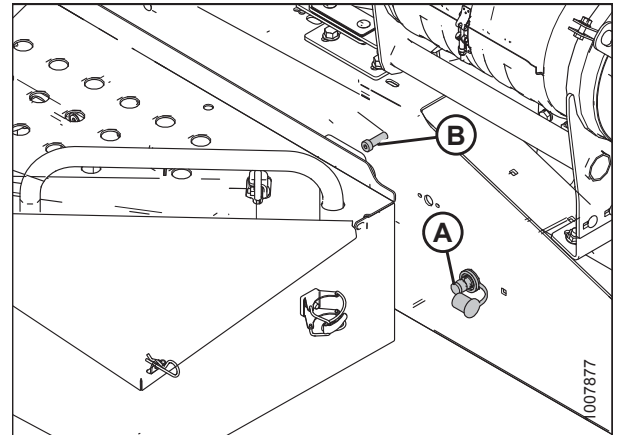

Figure 5.121: Battery Boost Posts

Adding Electrolyte to the Batteries

Before servicing batteries, consult the battery manufacturer’s instructions for proper procedures and safety precautions.

CAUTION

Do NOT attempt to service battery unless you have the proper equipment and experience to perform the job. Have it done by a qualified Dealer.

WARNING

Keep all smoking materials, sparks, and flames away from electrolyte container and battery. Gas given off by electrolyte is explosive.



Figure 5.122: Battery Safety Hazard

WARNING

- Battery electrolyte causes severe burns. Avoid contact with skin, eyes, or clothing. Wear protective eyewear and heavy gloves.
- If electrolyte is spilled or splashed on clothing or on the body, neutralize it immediately with a solution of baking soda and water, then rinse with clean water.
- Electrolyte splashed into the eyes is extremely dangerous. Should this occur, force the eye open, and flood with cool, clean water for 5 minutes. Call a doctor immediately.

WARNING

To avoid bodily injury or death from unexpected startup of the machine, always stop the engine and remove the key from the ignition before leaving the operator’s seat for any reason.

1. Shut down the engine, and remove the key from the ignition.
2. Open the hood to the highest position. For instructions, refer to [5.2.3 Opening Hood – Highest Position, page 316](#).
3. Move platform on the left cab-forward side of machine to open position. For instructions, refer to [5.3.1 Opening Platforms – Standard Position, page 318](#).
4. Add electrolyte in accordance with the battery manufacturer’s instructions.
5. Close the platform. For instructions, refer to [5.3.2 Closing Platforms – Standard Position, page 319](#).
6. Close the hood from the highest position. For instructions, refer to [5.2.4 Closing Hood – Highest Position, page 317](#).

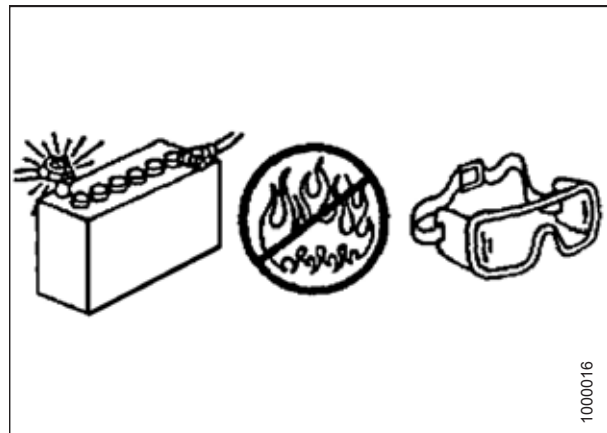

Figure 5.123: Battery Safety

Removing Batteries

WARNING

To avoid bodily injury or death from unexpected startup of the machine, always stop the engine and remove the key from the ignition before leaving the operator's seat for any reason.

CAUTION

Do NOT attempt to service battery unless you have the proper equipment and experience to perform the job. Have it done by a qualified Dealer.

1. Shut down the engine, and remove the key from the ignition.
2. Move platform on the right cab-forward side of machine to open position. For instructions, refer to [5.3.1 Opening Platforms – Standard Position, page 318](#).
3. Ensure battery main disconnect switch (A) is turned to the POWER OFF position.

NOTE:

The battery main disconnect switch is located on the right frame rail beside the batteries.

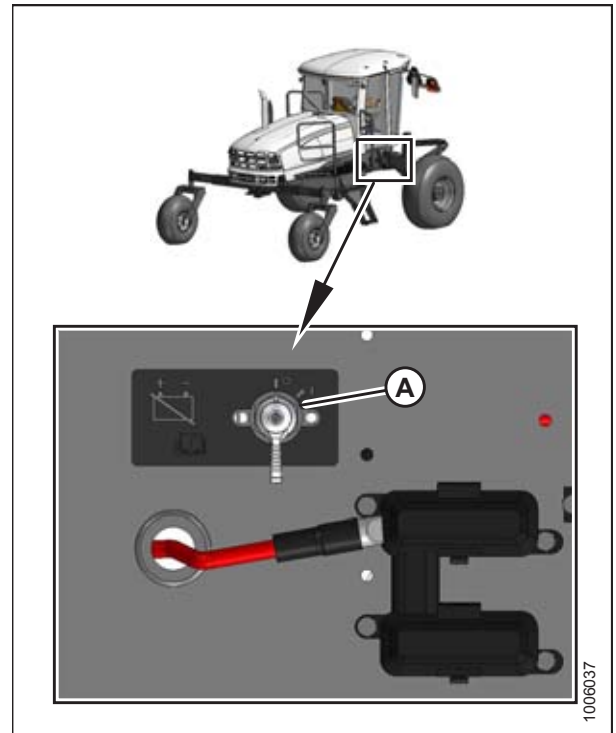

Figure 5.124: Battery Main Disconnect Switch

4. Remove bolt (A) that secures the platform arm to the platform. Swing arm (B) out of the way.
5. Remove the black plastic covers from negative cable clamps (D). Loosen clamps and remove cable from batteries.
6. Remove the red plastic covers from positive cable clamps (C). Loosen the clamps and remove cable from batteries.
7. Remove bolts (E) securing strap (F) to frame, and remove strap.

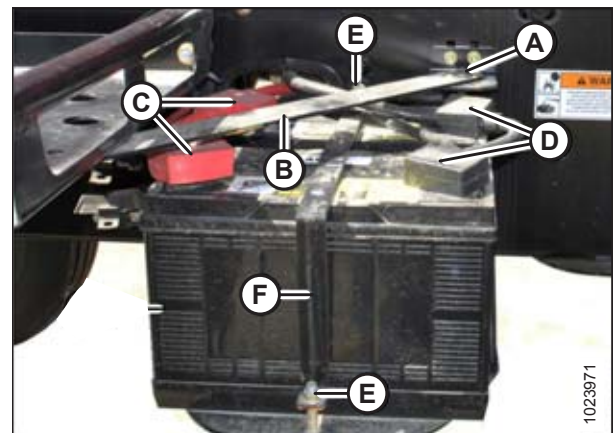

Figure 5.125: Batteries

MAINTENANCE AND SERVICING

- Lift batteries off holder (A).

IMPORTANT:

- Store batteries in a cool, dry area in an upright position.
- Do **NOT** stack batteries on top of each other unless they are in cartons.
- Test wet batteries every 4–6 months and recharge if necessary.

NOTE:

Dual battery support can be removed from frame by simply lifting support, and pulling it away from frame.

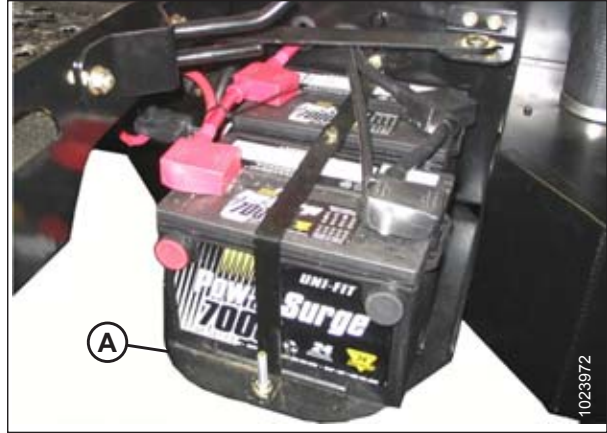

Figure 5.126: Battery Holder

Installing Batteries

Replacement batteries must meet the specifications shown in the following table:

Table 5.2 Battery Specification

Rating	Group	CCA (min)	Volt	Maximum Dimension
Heavy duty, off-road, vibration resistant	BCI 29H or 31A	650	12	334 x 188 x 232 mm (13.25 x 7.37 x 9.44 in.)

- Ensure battery main disconnect switch (A) is turned to the POWER OFF position.

NOTE:

The battery main disconnect switch is located on the right frame rail beside the batteries.

- Open right cab-forward platform to access the batteries. For instructions, refer to [5.3.1 Opening Platforms – Standard Position, page 318](#).
- Remove cable ties securing battery cables to battery clamp.

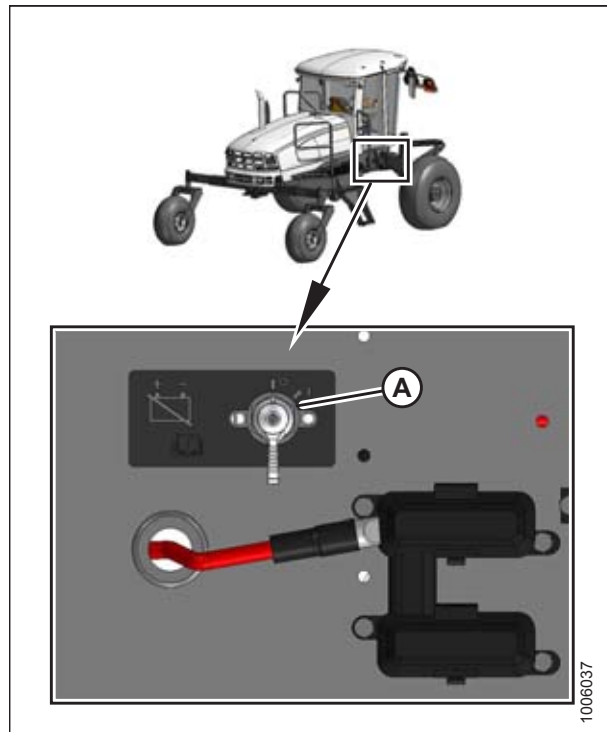

Figure 5.127: Battery Main Disconnect Switch

MAINTENANCE AND SERVICING

4. Position new batteries (G) on dual battery support.

NOTE:

Ensure that batteries are positioned so that positive posts (C) face aft.

5. Install strap (F) with bolts (E).
6. Rotate bar (B) into position and secure with bolt (A).
7. Connect battery cables to positive (C) and negative (D) battery posts. For instructions, refer to [Connecting Batteries, page 389](#).
8. Close the platform. For instructions, refer to [5.3.2 Closing Platforms – Standard Position, page 319](#).

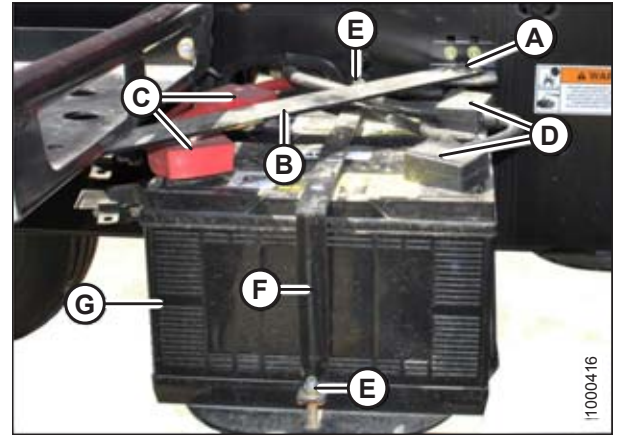

Figure 5.128: Battery

Connecting Batteries

WARNING

To avoid bodily injury or death from unexpected startup of the machine, always stop the engine and remove the key from the ignition before leaving the operator's seat for any reason.

1. Open the right (cab-forward) maintenance platform. For instructions, refer to [5.3.1 Opening Platforms – Standard Position, page 318](#).
2. Ensure battery main disconnect switch (A) is turned to the POWER OFF position.

NOTE:

The battery main disconnect switch is located on the right frame rail beside the batteries.

3. Remove the cable ties securing the battery cables to the battery clamps.

IMPORTANT:

Batteries are negative grounded. Always connect red starter cables to the positive (+) terminals of the batteries and black ground cables to the negative (–) terminals of the batteries. Reversed polarity in the batteries or alternator may result in permanent damage to the electrical system.

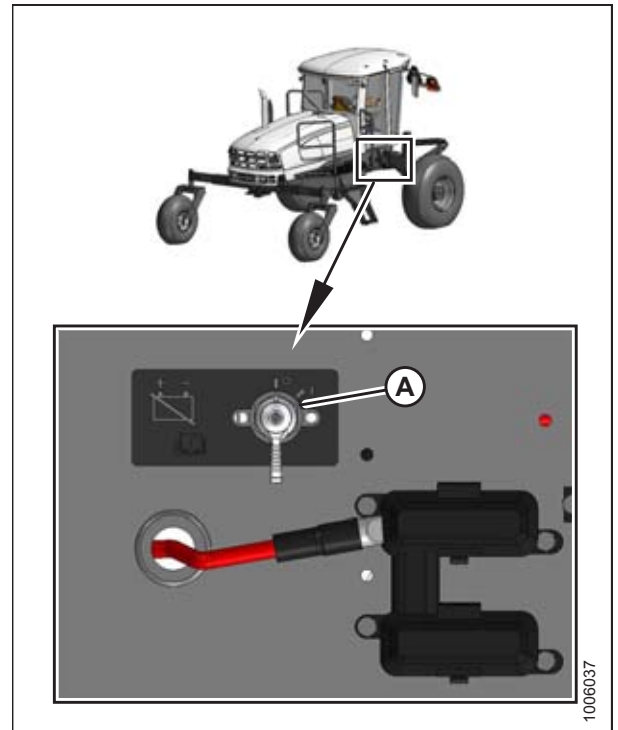

Figure 5.129: Battery Main Disconnect Switch

MAINTENANCE AND SERVICING

4. Remove the plastic caps from the battery posts.
5. Attach the red positive (+) cable terminals to positive posts (A) on the batteries and tighten clamps. Reposition plastic covers onto clamps.
6. Attach the black negative (-) cable terminals to negative posts (B) on the batteries and tighten clamps. Reposition plastic covers onto clamps.
7. Turn the battery main disconnect switch to the POWER ON position.
8. Close the platform. Refer to [5.3.2 Closing Platforms – Standard Position](#), page 319.

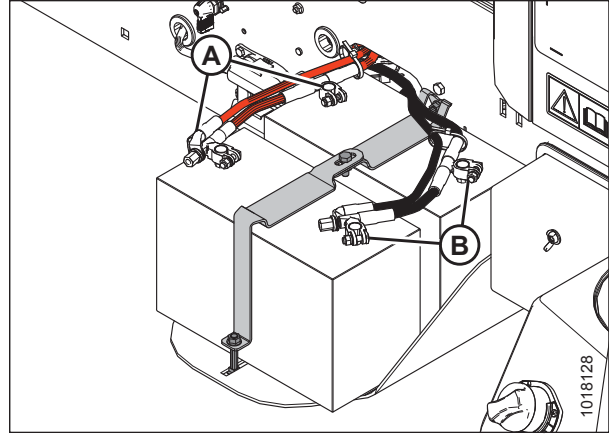

Figure 5.130: Batteries

5.9.3 Headlights – Engine-Forward

Replacing Headlight Bulb

Replacement bulb: MD #110267 (H4 12V 60/55W)

1. Remove two screws (A) and remove headlight assembly from hood.



Figure 5.131: Headlight

2. Pull wiring harness connector off the headlight assembly and remove rubber insulator boot (A).

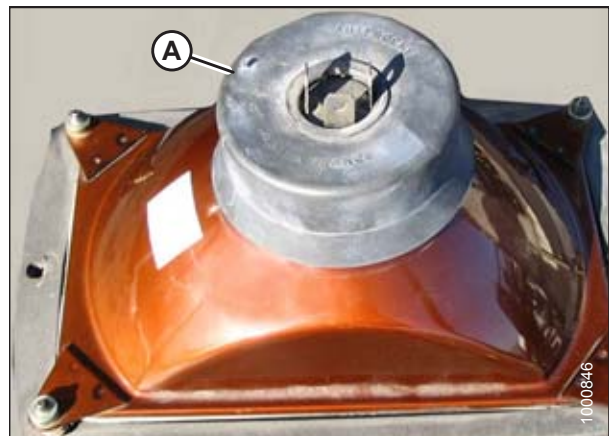

Figure 5.132: Headlight Assembly

MAINTENANCE AND SERVICING

3. Pinch wire retainer (A) and lift away from hooks.
4. Remove bulb (B) from body.

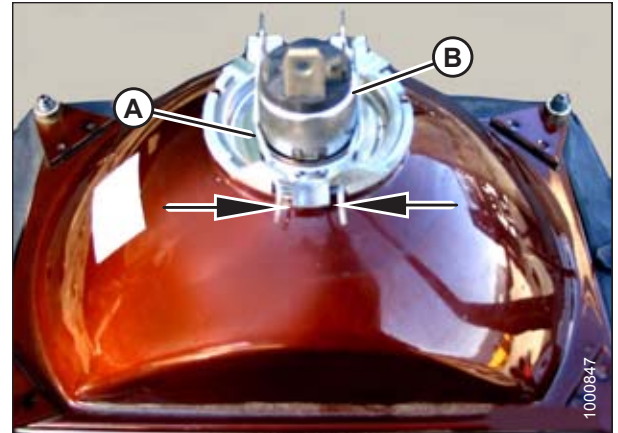

Figure 5.133: Headlight Assembly

5. Align lugs (B) on new bulb with slots (C) in body and push into place.

IMPORTANT:

Do **NOT** touch the glass of the halogen bulb as the oils or other chemicals from your skin will cause the bulb to fail prematurely.

6. Secure bulb with wire retainer (A).

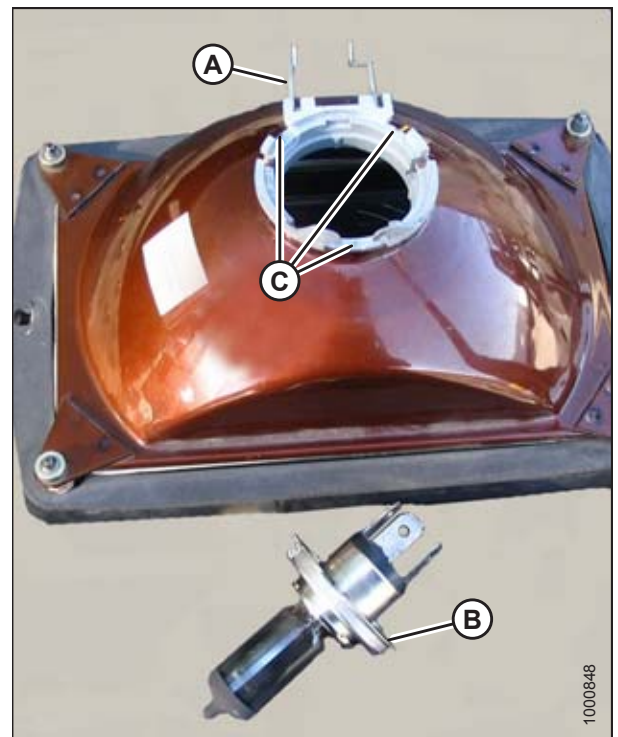

Figure 5.134: Headlight Assembly

MAINTENANCE AND SERVICING

7. Replace rubber insulator boot (A).
8. Push connector onto light bulb.

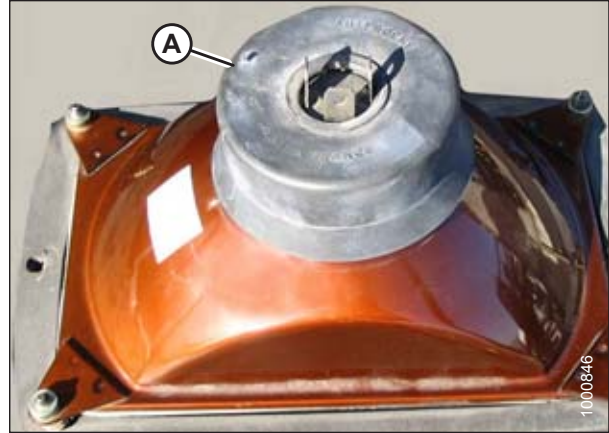

Figure 5.135: Headlight Assembly

9. Position headlight into light receptacle, ensuring top is up, and secure with screws (A). To align the headlights, refer to [Aligning Headlights, page 393](#).



Figure 5.136: Headlight

Aligning Headlights

WARNING

To avoid bodily injury or death from unexpected startup of the machine, always stop the engine and remove the key from the ignition before leaving the operator's seat for any reason.

NOTE:

Header should be attached and raised to maintain proper windrower stance.

1. Position windrower in engine-forward mode on level ground so that headlights are positioned 7.5 m (25 ft.) in front of a vertical surface.
2. Shut down the engine, and remove the key from the ignition.
3. Turn on ROAD lights (A) and switch to low beam (B).

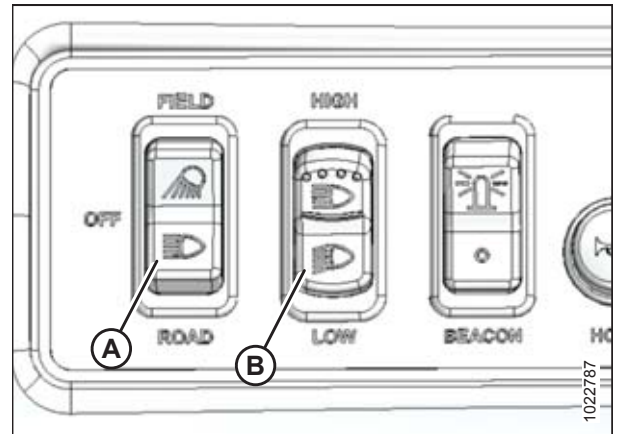

Figure 5.137: Road Light Switch (except Russia)

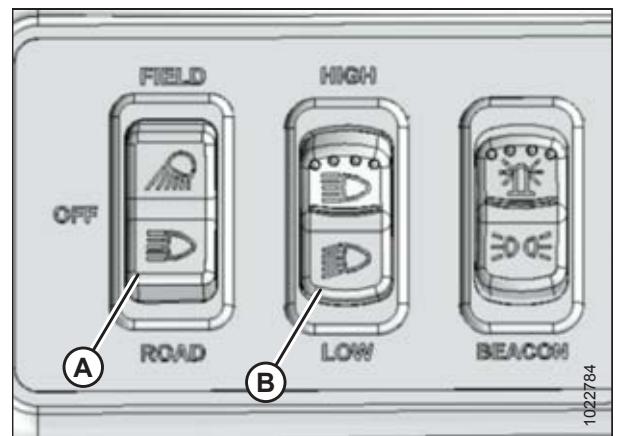

Figure 5.138: Road Light Switch (Russia Only)

MAINTENANCE AND SERVICING

4. Align the headlights to the following specifications by turning adjusting screws (A).
 - Adjustments are for low beam.
 - Light beams laterally centered on the direction of travel line from the headlights (that is, **NOT** skewed left or right).



Figure 5.139: Headlights

- Upper limit of the beam **NOT** higher than 1263 mm (49 3/4 in.) above ground at a distance of 7.5 m (25 ft.) from the headlight.

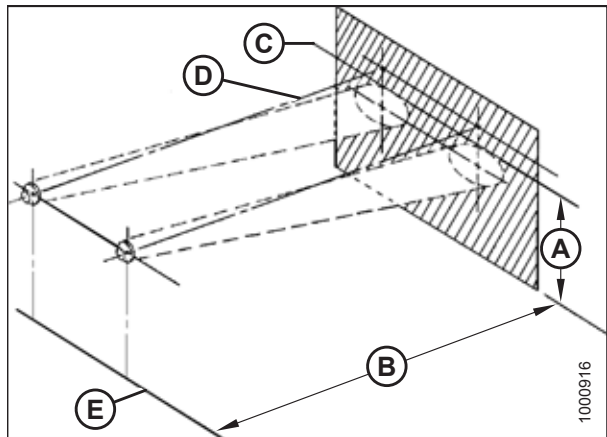

Figure 5.140: Headlight Beam Positioning

- A - 1263 mm (49 3/4 in.) Maximum
- B - 7.5 m (25 ft.)
- C - Top Edge of Beam
- D - Beam Centered on Direction of Travel Line
- E - Ground

5.9.4 Field Lights – Cab-Forward

Adjusting Field Lights

The field lights are best adjusted with the machine in the field (or equivalent) to suit Operator preference.

WARNING

To avoid bodily injury or death from unexpected startup of the machine, always stop the engine and remove the key from the ignition before leaving the operator's seat for any reason.

1. Hold onto handholds (A) on the cab front corners, and stand on header anti-slip strips.

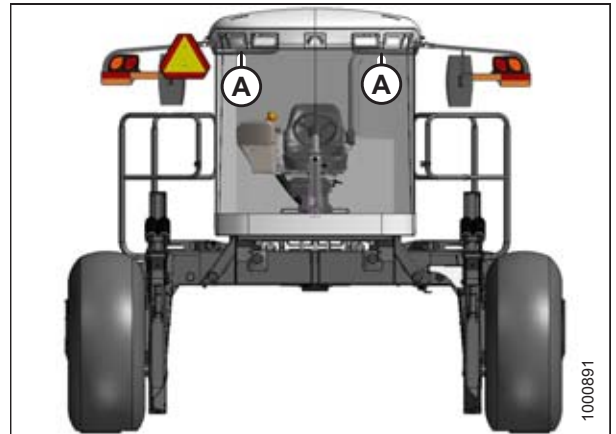

Figure 5.141: Windrower Cab-Forward

2. Adjust lights with screws (A).



Figure 5.142: Field Lights

MAINTENANCE AND SERVICING

Replacing Field Light Bulb

Replacement bulb: MD #110267 (H4 12V 60/55W)

1. Remove two screws (A), and remove light assembly.
2. Replace bulb as described in [Replacing Headlight Bulb, page 390](#).



Figure 5.143: Field Lights

5.9.5 Floodlights – Forward

Adjusting Forward Floodlights

The forward floodlights are **NOT** adjustable.

Replacing Bulb in Cab-Forward Flood Light

Replacement bulb: MD #109113 (H3 12V 55W)

Replace bulbs as follows:

WARNING

To avoid bodily injury or death from unexpected startup of the machine, always stop the engine and remove the key from the ignition before leaving the operator's seat for any reason.

1. Turn the lights OFF.
2. Shut down the engine, and remove the key from the ignition.
3. Remove two screws (B) and remove light bezel (C).

NOTE:

Hold onto handholds (A) on the cab's front corners and stand on the header anti-slip strips when removing the forward field lights.

4. Remove light from receptacle.

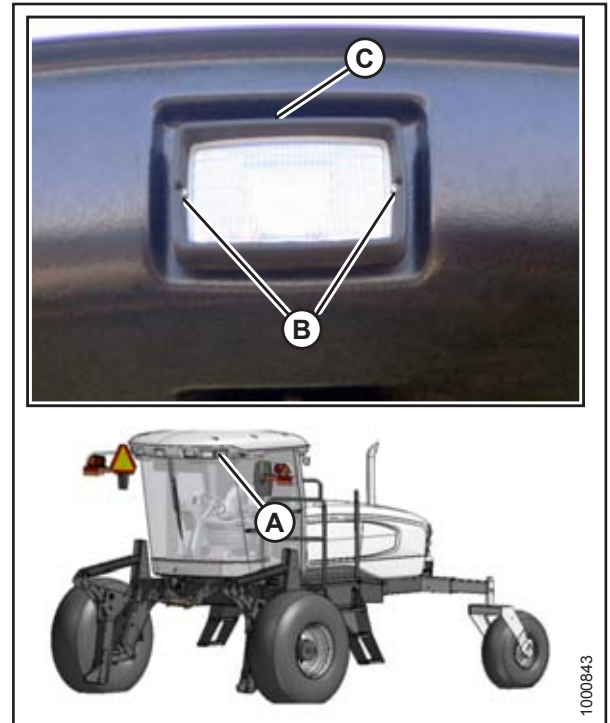

Figure 5.144: Forward Floodlights

MAINTENANCE AND SERVICING

5. Pinch wire retainer (A) and lift away from hooks.
6. Remove bulb (B) from body and pull wire from connector (C).

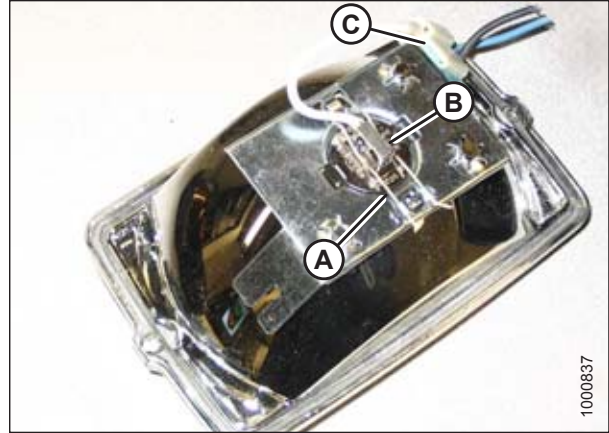

Figure 5.145: Floodlight Assembly

7. Match slots on new bulb (B) with lugs (D) in optical unit and insert bulb into unit.

IMPORTANT:

Do **NOT** touch the glass of the halogen bulb as the oils or other chemicals from your skin will cause the bulb to fail prematurely.

8. Secure bulb with wire retainer (A).
9. Push wire into connector (C).

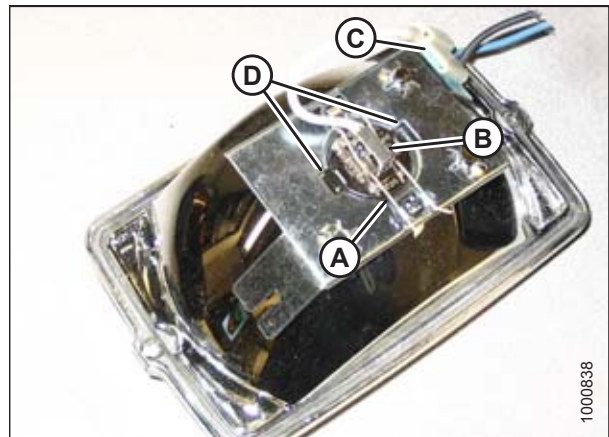

Figure 5.146: Floodlight Assembly

10. Position light into light receptacle, ensuring top is up, and secure with bezel (C) and screws (B).

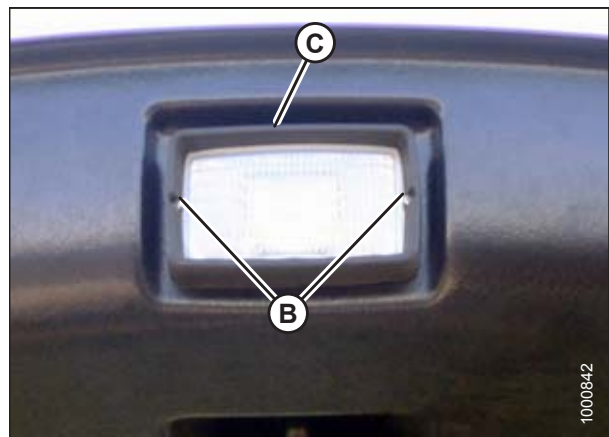

Figure 5.147: Forward Floodlight

5.9.6 High-Intensity Discharge (HID) Auxiliary Lighting (Optional – MD #B5596)

Two optional HID lights provide additional lighting during field operation. They operate only in cab-forward mode.

Adjusting High-Intensity Discharge (HID) Auxiliary Lights (if Installed)

If installed, HID auxiliary lights are best adjusted with the machine in the field (or equivalent) to suit Operator preference.

WARNING

To avoid bodily injury or death from unexpected startup of the machine, always stop the engine and remove the key from the ignition before leaving the operator's seat for any reason.

1. Shut down the engine, and remove the key from the ignition.
2. Turn the lights ON.
3. Loosen bolt (A) and nut (C) (located inside the light/mirror support).
4. Position light (B) to desired position.
5. Tighten bolt and nut.

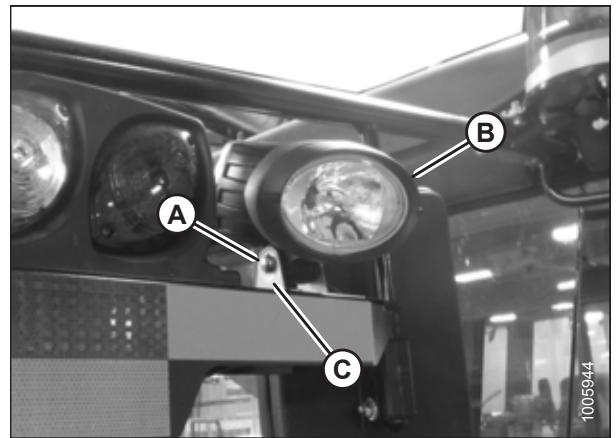

Figure 5.148: HID Auxiliary Lights

Replacing High-Intensity Discharge (HID) Auxiliary Lights (if Installed)

To remove and replace the lamp only, follow these steps:

WARNING

To avoid bodily injury or death from unexpected startup of the machine, always stop the engine and remove the key from the ignition before leaving the operator's seat for any reason.

1. Turn the lights OFF.
2. Shut down the engine and the remove key from the ignition.

NOTE:

Hold onto the handholds (A) on the cab front corners and stand on the header anti-slip strips, or stand on the maintenance platform when accessing the HID auxiliary lights.

3. Remove nut, spring washer, and bolt (A) that secure lamp (B) to lamp bracket (C).
4. Remove lamp (B).
5. Position new lamp (B) in lamp bracket (C) and secure with bolt (A), spring washer, and nut.
6. Adjust lamp (B) to desired position and tighten bolt (A).

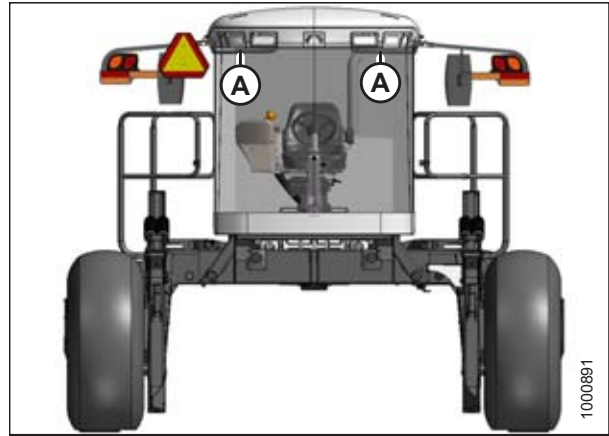

Figure 5.149: Cab-Forward Lights

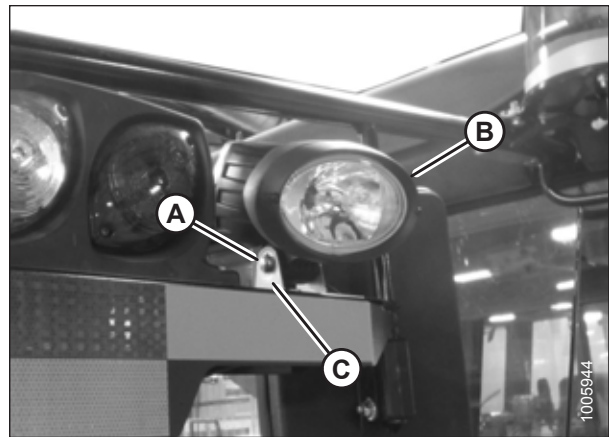

Figure 5.150: HID Auxiliary Lights

MAINTENANCE AND SERVICING

To remove and replace the HID lamp assembly, follow these steps:

7. Disconnect lamp connector (A) from electrical harness (B).

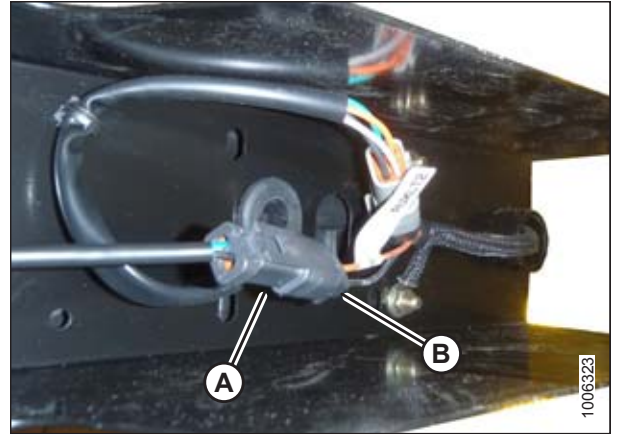

Figure 5.151: HID Auxiliary Light Harness

8. Remove grommet (A) from light support (B).
9. Remove nut (C) and spring washer from inside light support (B).
10. Remove the lamp assembly.

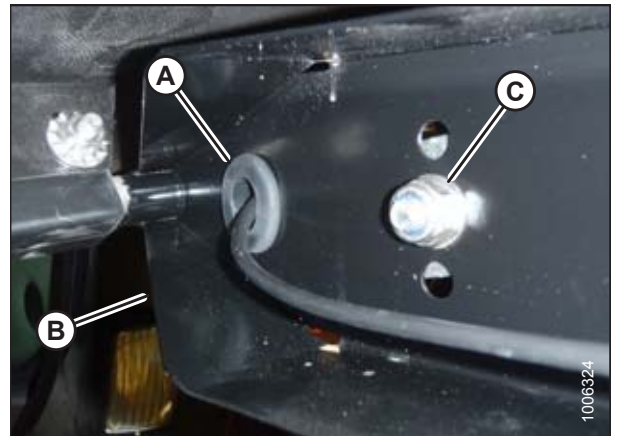

Figure 5.152: HID Light Assembly

11. Locate light in center hole in light support (B) and secure with hardware (C) provided with light assembly.
12. Adjust light assembly to desired position and tighten nut (C).
13. Reinstall grommet (A) in light support (B).
14. Route lamp harness through grommet (A) and slot in light support (B).

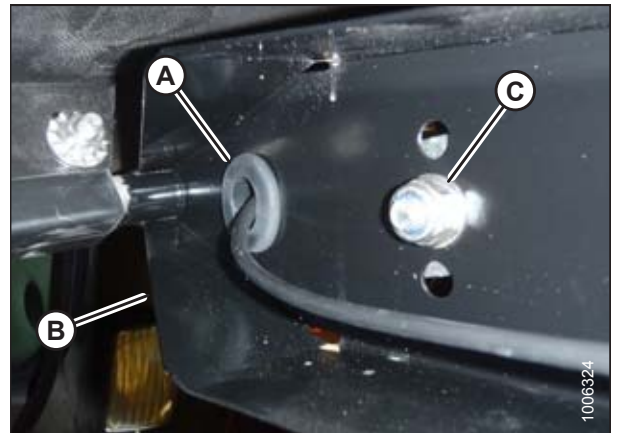

Figure 5.153: HID Light Assembly

MAINTENANCE AND SERVICING

15. Connect lamp plug (A) to main harness connector (B).

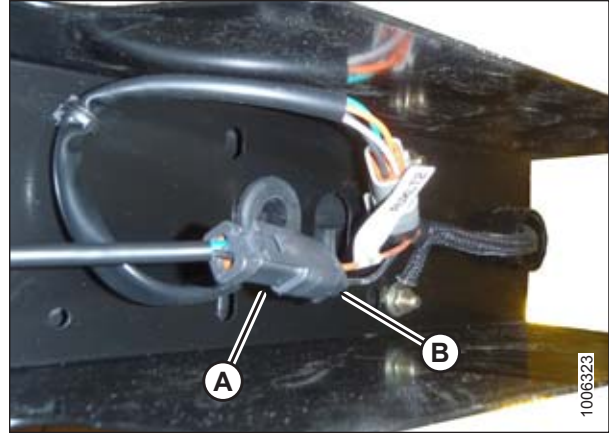

Figure 5.154: HID Auxiliary Light Harness

5.9.7 Floodlights – Rear

Adjusting Rear Floodlights

The rear floodlights are best adjusted with the machine in the field (or equivalent) to suit Operator preference.

WARNING

To avoid bodily injury or death from unexpected startup of the machine, always stop the engine and remove the key from the ignition before leaving the operator's seat for any reason.

1. Shut down the engine, and remove the key from the ignition.
2. Turn the lights ON.
3. Loosen bolts (A) and (B).
4. Position light to desired position.
5. Tighten bolts (A) and (B).

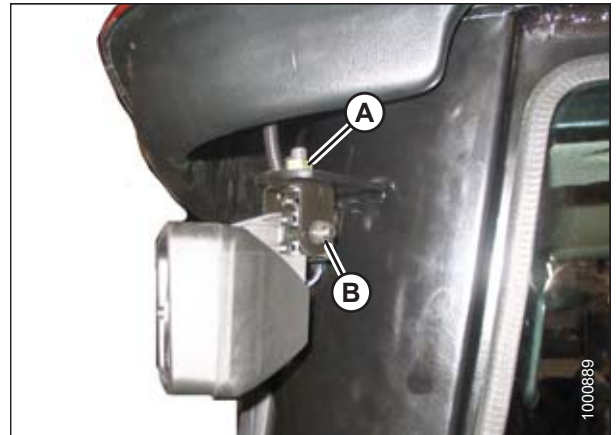

Figure 5.155: Rear Flood Light

Replacing Bulb in Rear Flood Light

Replacement bulb: MD #109113 (H3 12V 55W)

WARNING

To avoid bodily injury or death from unexpected startup of the machine, always stop the engine and remove the key from the ignition before leaving the operator's seat for any reason.

1. Shut down the engine, and remove the key from the ignition.
2. Turn the lights OFF.
3. Remove two screws (A) and remove light bezel (B).
4. Remove light from receptacle.

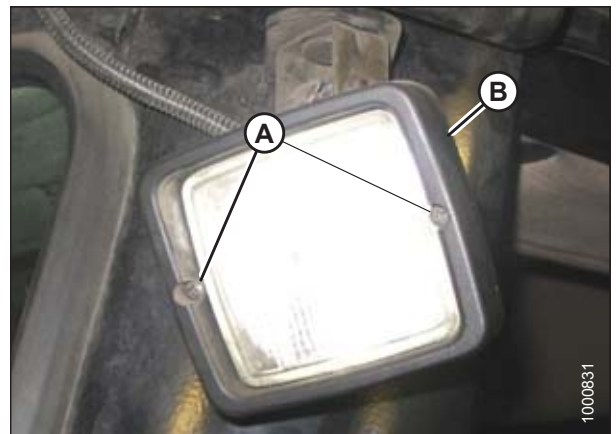

Figure 5.156: Rear Flood Light

MAINTENANCE AND SERVICING

- Pinch wire retainer (A) and lift away from hooks.

IMPORTANT:

Do **NOT** touch the glass of the halogen bulb as the oils or other chemicals from your skin will cause the bulb to fail prematurely.

- Remove bulb (B) from body and pull wire from connector (D).
- Match slots on new bulb (B) with lugs (C) in optical unit and insert bulb into unit.
- Secure bulb with wire retainer (A).
- Push wire into connector (D).
- Position light into light receptacle, ensuring top is up.
- Secure with bezel (B) and screws (A).

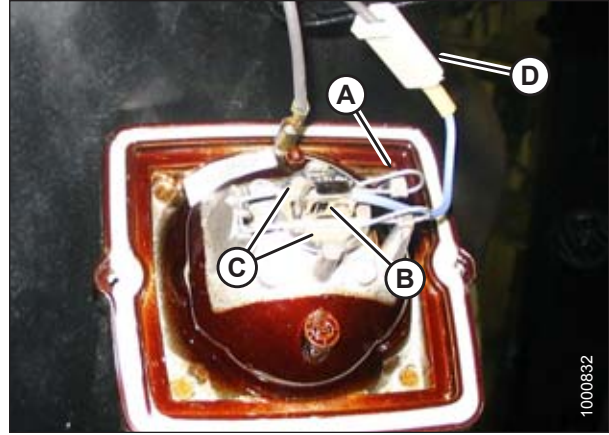

Figure 5.157: Rear Flood Light Assembly

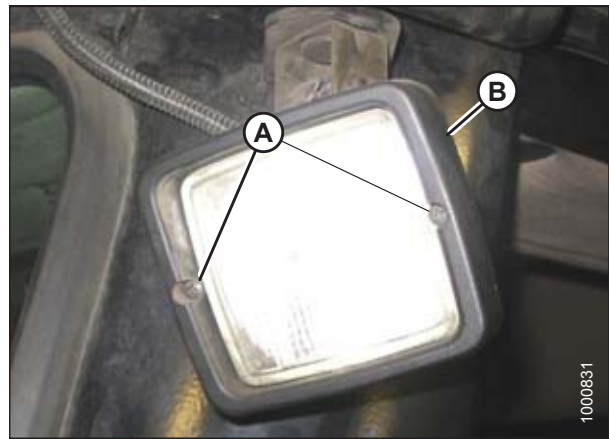

Figure 5.158: Rear Flood Light

5.9.8 Replacing Bulbs in Red and Amber Lights

To replace bulbs in red and amber lights, follow these steps:

WARNING

To avoid bodily injury or death from unexpected startup of the machine, always stop the engine and remove the key from the ignition before leaving the operator's seat for any reason.

1. Shut down the engine, and remove the key from the ignition.
2. Turn the lights OFF.

NOTE:

Hold onto handholds (A) on the cab front corners and stand on the header anti-slip strips, or stand on the maintenance platform when accessing the red and amber lights.

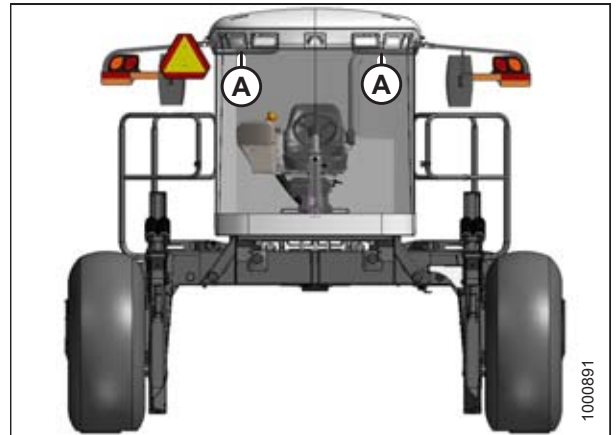

Figure 5.159: Windrower Cab-Forward

3. Remove two screws (A) from lens and remove lens.
4. Push and twist light bulb to remove from socket.
5. Install new bulb in socket ensuring that bulb base is properly engaged in socket.
 - Use Bulb Trade #1157 for red taillights
 - Use Bulb Trade #1156 for amber lights
6. Reinstall lens with screws (A).

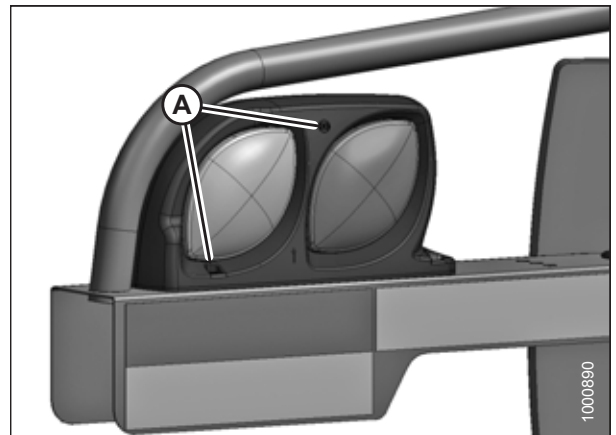

Figure 5.160: Red and Amber Lights

5.9.9 Replacing Red Taillights

Red taillights are included with the Lighting and Marking for Cab-Forward Road Travel Kit (MD #B5412). To replace the red taillights, follow these steps:

WARNING

To avoid bodily injury or death from unexpected startup of the machine, always stop the engine and remove the key from the ignition before leaving the operator's seat for any reason.

1. Shut down the engine and remove the key.
2. Turn lights OFF.
3. In the grill of the hood, remove two screws (A) from light (B), and remove light.
4. Remove connector from light.
5. Connect wiring harness to new light (B) and install light with screws (A).

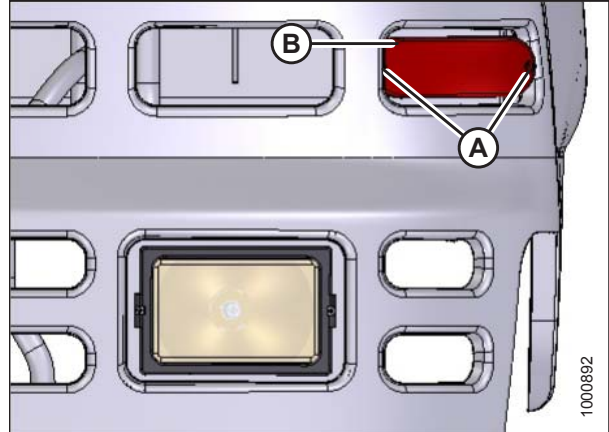

Figure 5.161: Red Taillights

5.9.10 Replacing Beacon Lights

1. Disconnect wiring (A) from harness.
2. Remove nuts (B) and remove beacon (C) from support (D). Discard defective beacon and hardware.
3. Clean residue from support (D) mounting surface.
4. Install new beacon (C) with gasket (E) onto support and secure with bolts (F), washers (G), and nuts (B).
5. Torque nuts to 0.65 Nm (5.75 lbf-in). Do **NOT** exceed 2.0 Nm (17.7 lbf-in) under any circumstances.
6. Connect wiring (A).
7. Check operation of beacons. For instructions, refer to [3.7 Exterior Lighting, page 49](#).

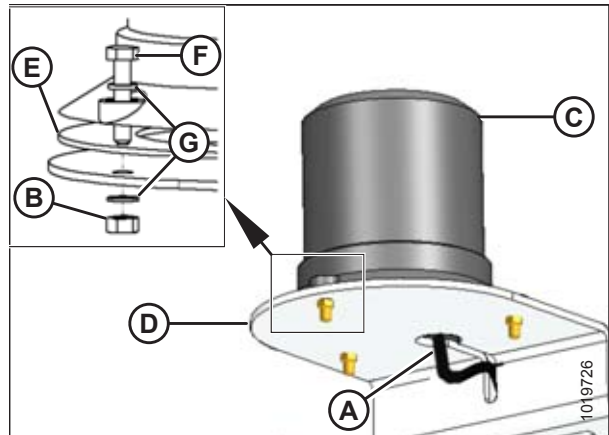

Figure 5.162: Replacing Beacons

5.9.11 Replacing a Console Gauge Light

To replace a light inside one of the console gauges, follow these steps:

WARNING

To avoid bodily injury or death from unexpected startup of the machine, always stop the engine and remove the key from the ignition before leaving the operator's seat for any reason.

1. Shut down the engine, and remove the key from the ignition.
2. Turn the lights OFF.
3. Remove the appropriate gauge access hole decal (A) behind the operator's console.

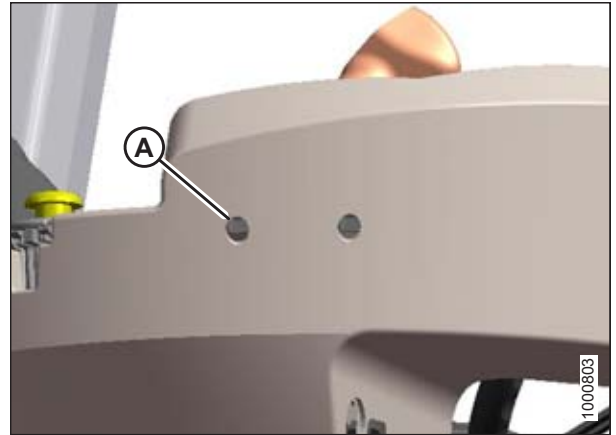

Figure 5.163: Operator Console

4. Remove nut (B) securing mounting bracket (C) to gauge inside the console.
5. Pull gauge out from console. It's not necessary to disconnect the wiring harness from the back of gauge.
6. Twist bulb holder (A) counterclockwise until loose and pull bulb holder from back of gauge.
7. Insert new bulb into gauge and turn clockwise until it locks.
8. Push gauge into console.
9. Locate bracket (C) onto back of gauge and secure with nut (B). Tighten nut.
10. Replace gauge access hole decal.

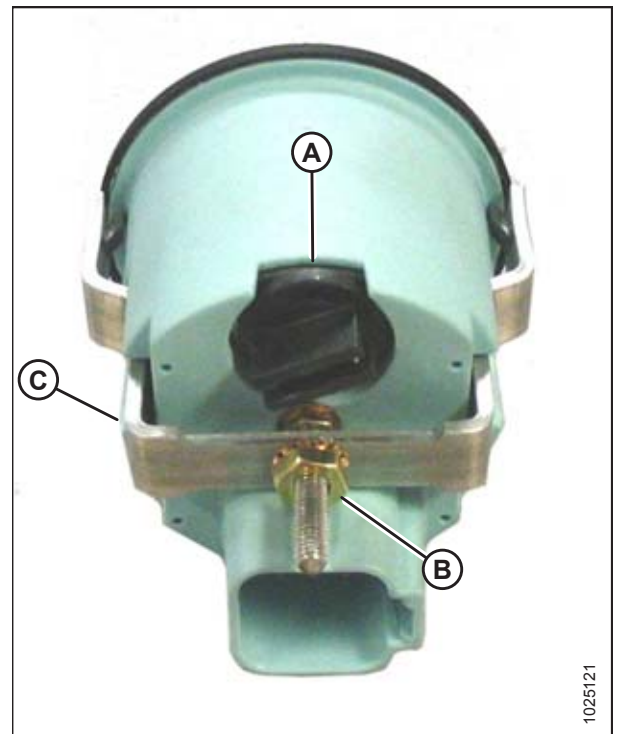

Figure 5.164: Back of Console Gauge

5.9.12 Replacing the Cabin Dome Light

To replace a cabin dome light in the headliner switch panel, follow these steps:

1. Remove two screws (A) from the dome light assembly and remove the assembly.
2. Disconnect the old dome light assembly from the wiring harness.
3. Connect the new dome light (MD #183413) to the wiring harness.
4. Install the new dome light assembly with two screws (A).

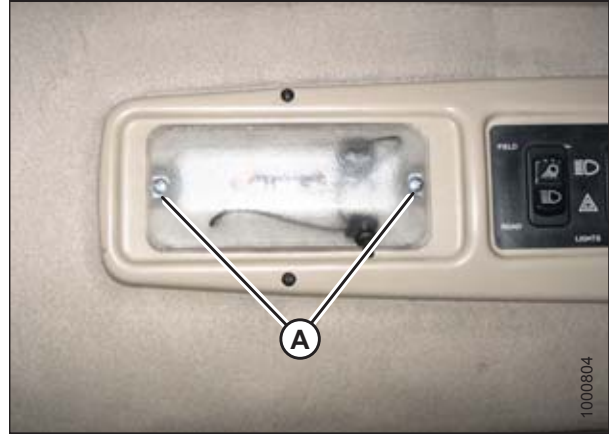

Figure 5.165: Cabin Dome Light

5.9.13 Replacing the Ambient Light Fixture

To replace the ambient light fixture, follow these steps:

1. Locate ambient light fixture (A) in the roof liner.

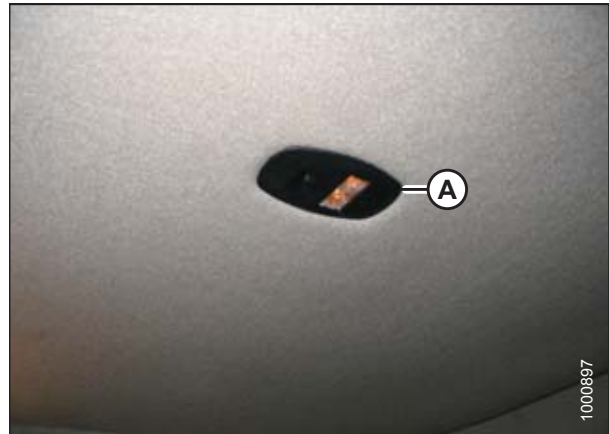

Figure 5.166: Ambient Light Fixture

2. Push new light fixture against tabs (A) with a screwdriver and pull ambient light fixture out of cab roof.
3. Remove wires from connectors (B).
4. Connect wires to new light fixture.
5. Push into place in cab roof until tabs hold fixture in place.

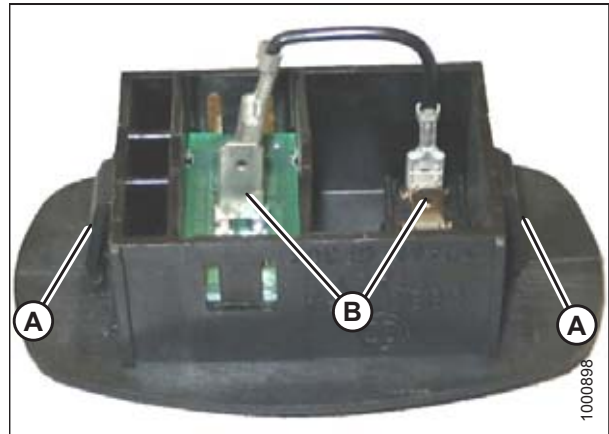

Figure 5.167: Ambient Light Fixture

5.9.14 Turn Signal Indicators

If the turn signal indicators on the console do not function, contact your MacDon Dealer.

5.9.15 Circuit Breakers and Fuses

The circuit breakers and fuses are located inside a fuse box mounted on the right (cab-forward) side of the frame under the platform.

Accessing Circuit Breakers and Fuses

Access the breakers and fuses as follows:

WARNING

To avoid bodily injury or death from unexpected startup of the machine, always stop the engine and remove the key from the ignition before leaving the operator's seat for any reason.

1. Stop engine and remove key.
2. Move right (cab-forward) side platform rearward. Refer to [5.3.1 Opening Platforms – Standard Position, page 318](#).
3. Remove wing nut (A) and remove fuse box cover (B).
4. A cover may be installed over the circuit breaker. Remove it to access the breaker.

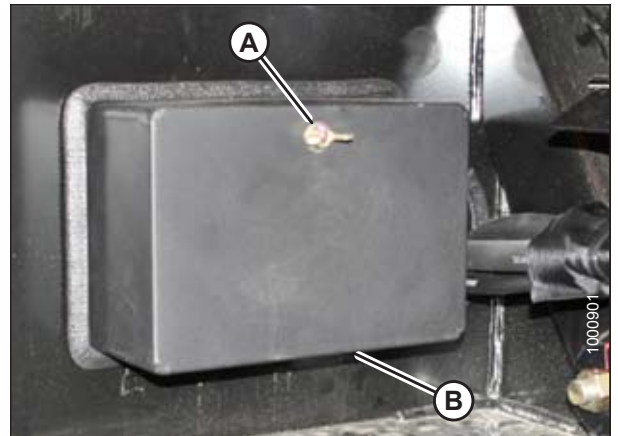

Figure 5.168: Fuse Box

Checking and Replacing Fuses

WARNING

To avoid bodily injury or death from unexpected startup of the machine, always stop the engine and remove the key from the ignition before leaving the operator’s seat for any reason.

1. Stop the engine and remove the key.
2. Open the right (cab-forward) platform. Refer to *5.3.1 Opening Platforms – Standard Position, page 318*.
3. Remove fuse box cover. Refer to *Accessing Circuit Breakers and Fuses, page 409*.
4. Refer to the decal on inside of cover for identification of fuses and circuit breakers.
5. To check fuse, pull fuse out of receptacle and visually examine.
6. To replace fuse, insert new fuse into receptacle.

IMPORTANT:

Replacement fuses should match rating on decal shown on *Fuse Box Decal, page 411*.

7. Reinstall cover and secure with wing nut.

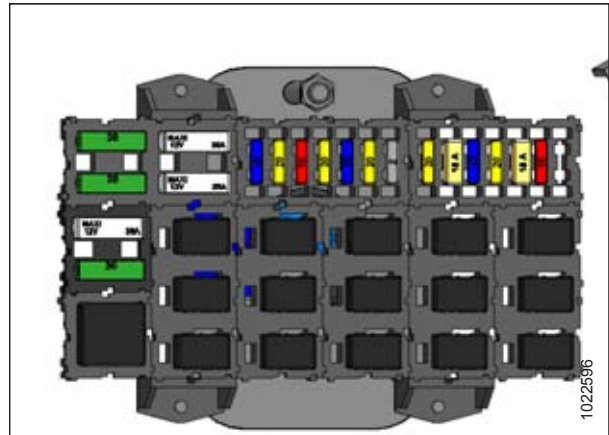

Figure 5.169: Fuses and Circuit Breakers

Replacing Circuit Breakers and Relays

Replace breakers and relays as follows:

WARNING

To avoid bodily injury or death from unexpected startup of the machine, always stop the engine and remove the key from the ignition before leaving the operator’s seat for any reason.

1. Stop engine and remove key.
2. Move right cab-forward platform rearward (cab-forward).
3. Remove fuse box cover. Refer to *Accessing Circuit Breakers and Fuses, page 409*.
4. To replace circuit breaker (A), pull breaker out of receptacle and install new circuit breaker.
5. To replace relay (B), pull relay out of receptacle and install new relay.
6. Reinstall cover and secure with wing nut.

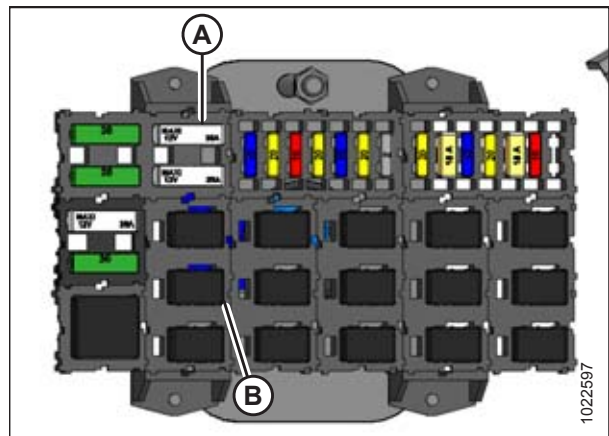
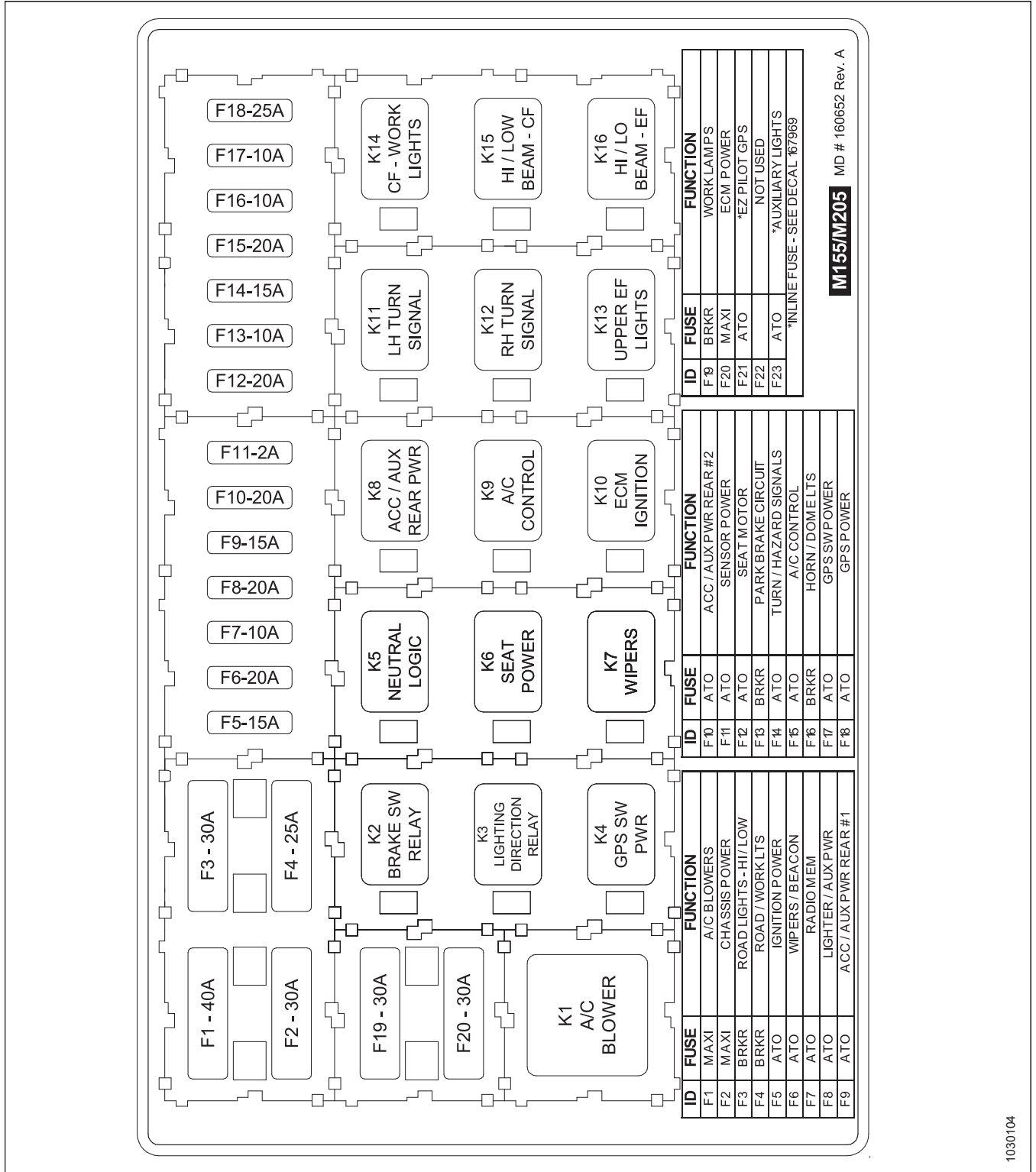

Figure 5.170: Relays and Breakers

MAINTENANCE AND SERVICING

Fuse Box Decal

Figure 5.171: Fuse Decal



MAINTENANCE AND SERVICING

Inspecting and Replacing 125A Main Fuses

The 125A main fuse holders are located on the frame under the right cab-forward platform beside the battery.

WARNING

To avoid bodily injury or death from unexpected startup of the machine, always stop the engine and remove the key from the ignition before leaving the operator's seat for any reason.

1. Stop engine and remove key.
2. Move right (cab-forward) platform rearward.
3. To check condition of fuse, pull tab (A) and open cover (B).

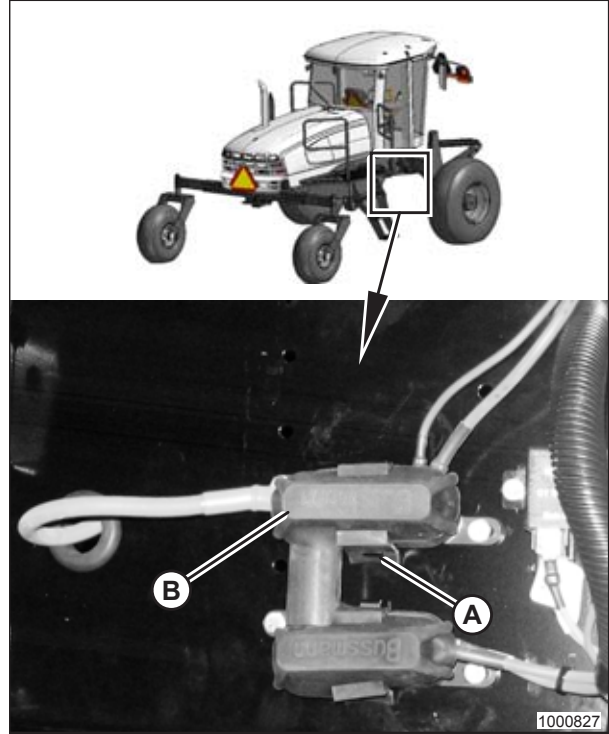

Figure 5.172: 125A Main Fuses

4. Visually examine fuse (B) for indications of melting.
5. To remove fuse (B), remove two nuts (C) and pull fuse free from holder.

NOTE:

The existing wiring may need to be pulled off the stud first.

6. Install new fuse on studs and any existing wiring that was removed.
7. Secure with nuts (C).

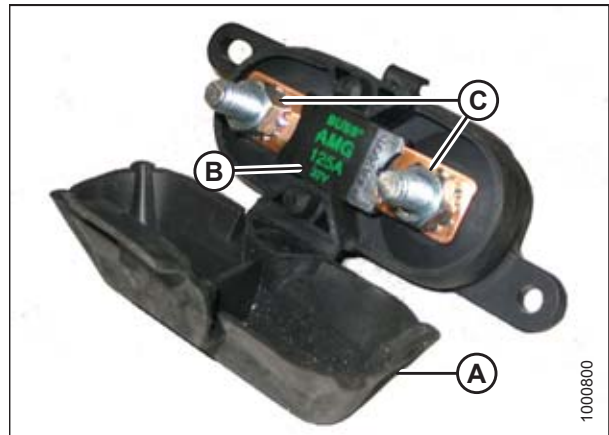

Figure 5.173: 125A Main Fuse

MAINTENANCE AND SERVICING

8. Close cover (B) and secure with tab (A).
9. Return platform to operating position. Ensure lock engages.

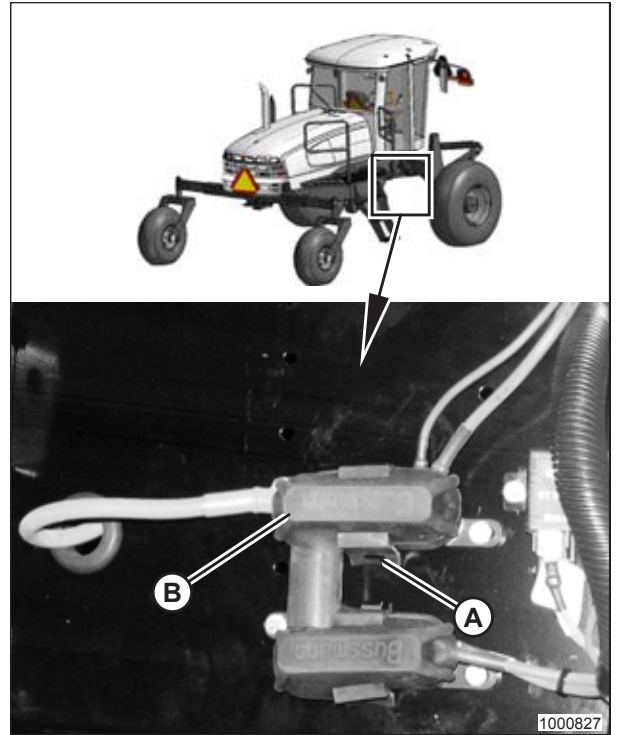

Figure 5.174: 125A Main Fuses

5.10 Hydraulic System

The windrower hydraulic system provides oil pressure for the header lift, the windrower drive, and header drive systems.

WARNING

- Avoid high pressure fluids. Escaping fluid can penetrate the skin causing serious injury. Relieve pressure before disconnecting hydraulic lines.
- Tighten all connections before applying pressure. Keep hands and body away from pin-holes and nozzles which eject fluids under high pressure.



Figure 5.175: Hydraulic Pressure Hazard

WARNING

- Use a piece of cardboard or paper to search for leaks.
- If ANY fluid is injected into the skin, it must be surgically removed within a few hours by a doctor familiar with this type of injury or gangrene may result.

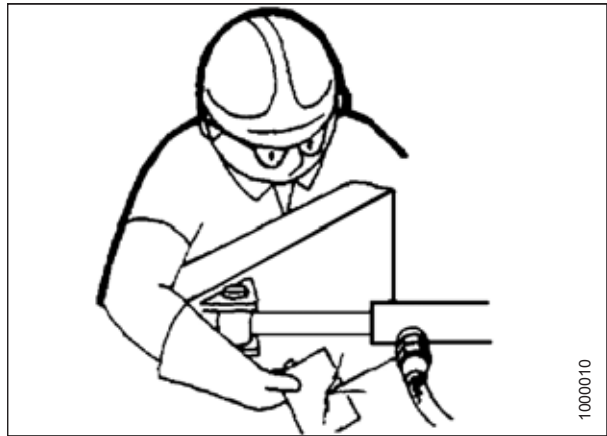

Figure 5.176: Checking Hydraulic Leaks

IMPORTANT:

Foreign materials such as dirt, dust, and water are the major cause of damage in the hydraulic system.

If hydraulic system components must be disconnected for service, protect the ends of hoses, tubing, and ports of components from contamination with clean, lint-free towels, or clean plastic bags.

Before installing any replacement hose, flush the inside with unused diesel fuel or unused commercial petroleum cleaning solvent for 10 seconds minimum. Do **NOT** use water, water soluble cleaners, or compressed air.

The hydraulic system components are built to very close tolerances and have been adjusted at the factory. Do **NOT** attempt to service these components except to maintain proper oil level, change oil and filters, and to adjust relief pressures as described in this manual.

See your MacDon Dealer for all other service.

5.10.1 Checking and Filling Hydraulic Oil

WARNING

To avoid bodily injury or death from unexpected startup of the machine, always stop the engine and remove the key from the ignition before leaving the operator's seat for any reason.

1. Park the windrower on a level surface.
2. Lower the reel fully.
3. Lower the header fully.
4. Shut down the engine, and remove the key from the ignition.
5. Open the hood to the lower position. For instructions, refer to *5.2.1 Opening Hood – Lower Position, page 314*.

NOTE:

A sight glass (A) is provided under the hood on the right side of the tank. It indicates oil level and signs of contamination. No oil in the sight glass indicates oil level is below the add mark on the dipstick.

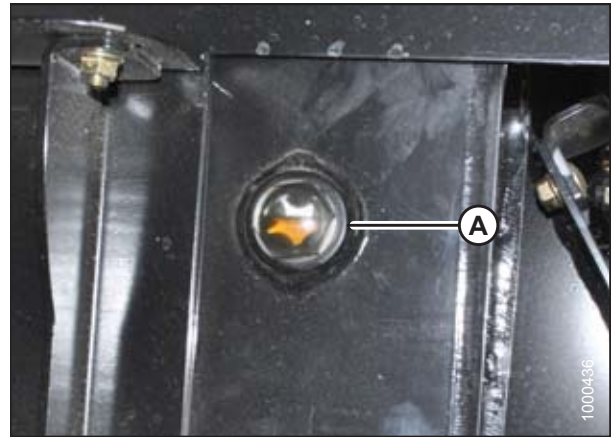

Figure 5.177: Hydraulic Oil Sight Glass

6. Stand on left (cab-forward) platform to access the filler pipe.
7. Clean cap (A) and surrounding area.
8. Turn filler cap (A) counterclockwise to unlock cap and remove dipstick.

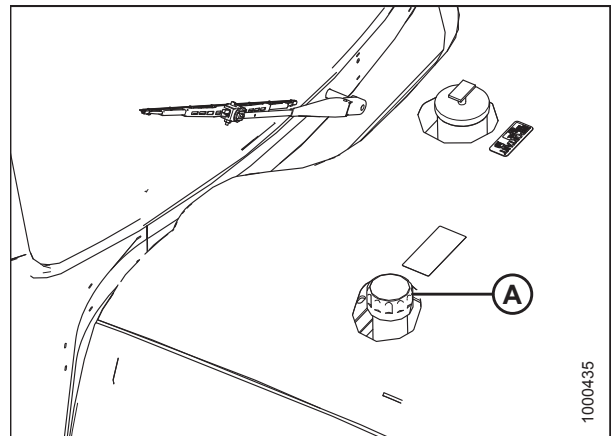

Figure 5.178: Engine Hood

- If necessary, add oil to maintain a level between the low (L) and high (H) marks. Refer to the inside back cover of this manual for hydraulic oil specifications and quantity.

NOTE:

When dipstick is showing low (L), approximately 4 liters (1 US gallon) is required to reach the full (H) mark.

IMPORTANT:

- Use new, good quality, prefiltered clean oil
 - Exercise care to prevent debris from falling into tank
- Reinstall dipstick and filler cap, and turn clockwise to tighten and lock.
 - Close the hood. Refer to [5.2.2 Closing Hood – Lower Position, page 315](#).

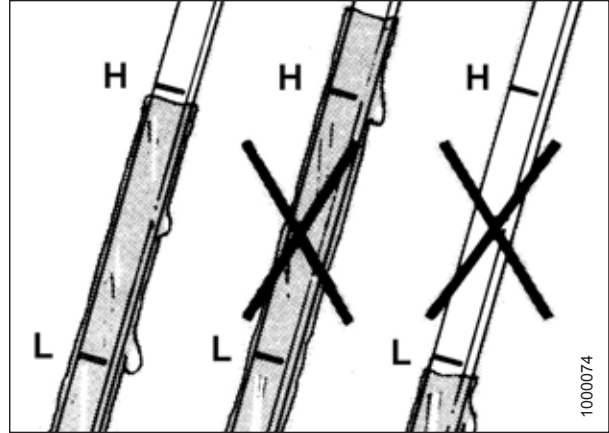

Figure 5.179: Hydraulic Oil Levels

5.10.2 Hydraulic Oil Cooler

The hydraulic oil cooler is located inside the cooling box behind the radiator.

It should be cleaned daily with compressed air. Refer to [Cleaning Cooler Box Components, page 372](#).

5.10.3 Changing the Hydraulic Oil

Hydraulic oil should be changed every 1500 hours or every 2 years.

To drain hydraulic oil, follow these steps:

WARNING

To avoid bodily injury or death from unexpected startup of the machine, always stop the engine and remove the key from the ignition before leaving the operator's seat for any reason.

1. Park the windrower on a level surface.
2. Lower the reel fully.
3. Lower the header fully.
4. Shut down the engine, and remove the key from the ignition.
5. Open the hood to the highest position. For instructions, refer to [5.2.3 Opening Hood – Highest Position, page 316](#).
6. Place a clean container (at least 75 liters [20 US gallons]) under drain at the bottom of the hydraulic reservoir to collect the oil.

MAINTENANCE AND SERVICING

7. Remove drain plug (A) and allow oil to drain.
8. Inspect plug and clean off any metal debris that may have accumulated on magnetic plug. Wipe plug with a clean cloth. Check O-ring condition. Look for cracking, breakage, or deformation that may impede sealing ability and replace as required.
9. Install drain plug (A), and torque to 80 Nm (59 lbf-ft).
10. Fill hydraulic oil reservoir. Refer to [5.10.1 Checking and Filling Hydraulic Oil, page 415](#).

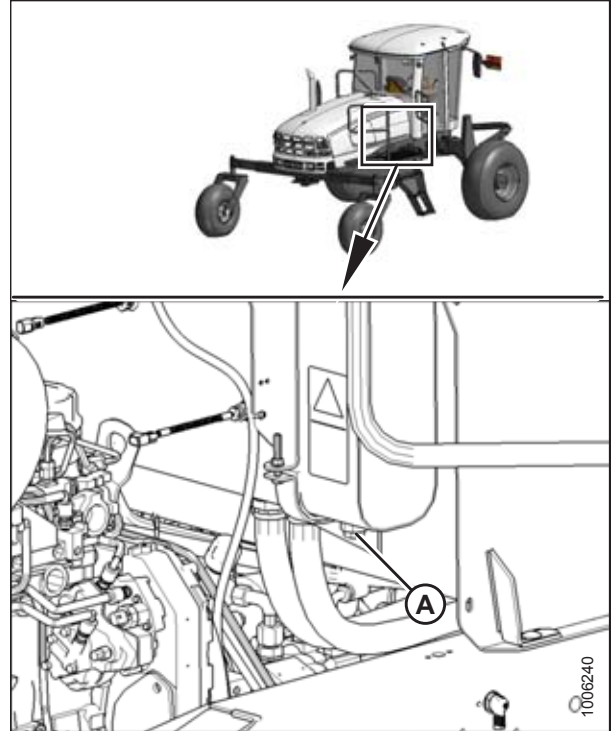

Figure 5.180: Hydraulic Oil Drain Plug

5.10.4 Changing Hydraulic Oil Filters

Change hydraulic oil filters after the first 50 hours of operation, and every 500 hours thereafter. Filter (A) (MD #112419) and service kit for filter (B) (MD #183620) can be obtained from your Dealer.

The charge oil filter (A) and return oil filter (B) are located just inside the frame on the left side of the windrower and are accessible from under the windrower.

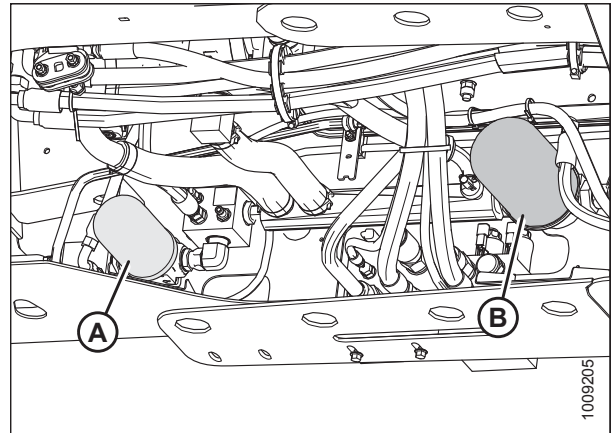

Figure 5.181: Hydraulic Oil Filters

Charge Oil Filter

The charge oil filter cleans the oil in the hydraulic charge circuit. The charge circuit replenishes oil losses that occur normally at the motor and pump case drains and associated circuits.

Refer to the following procedures to change the charge oil filter:

- [Removing Charge Oil Filter, page 418](#)
- [Installing Charge Oil Filter, page 418](#)

Removing Charge Oil Filter

WARNING

To avoid bodily injury or death from unexpected startup of the machine, always stop the engine and remove the key from the ignition before leaving the operator's seat for any reason.

1. Shut down the engine, and remove the key from the ignition.
2. Clean around head of filter (A).
3. Place a container beneath the filter to collect any oil that may leak out.
4. Unscrew filter (A) with a filter wrench.
5. Dispose of used oil and filter in accordance with local legislation.

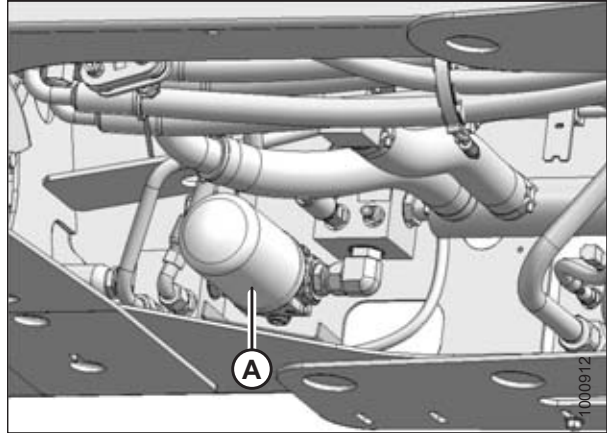

Figure 5.182: Charge Oil Filter

Installing Charge Oil Filter

NOTE:

For charge oil filter replacement part number, refer to [8.2.4 Filter Part Numbers, page 480](#).

1. Clean the gasket surface of the filter head.
2. Apply a thin film of clean oil to the filter gasket.
3. Screw new filter (A) onto the mount until the gasket contacts the filter head.
4. Tighten filter an additional 1/2 turn by hand.

IMPORTANT:

Do **NOT** use a filter wrench to install oil filter. Overtightening can damage gasket and filter.

5. Check hydraulic fluid levels and add fluid if needed. Refer to [5.10.1 Checking and Filling Hydraulic Oil, page 415](#).

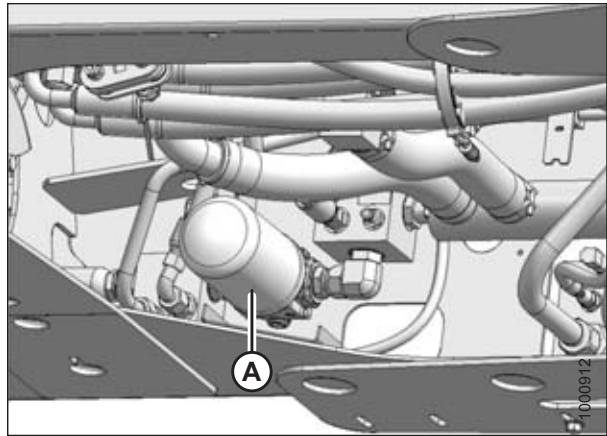

Figure 5.183: Charge Oil Filter

Return Oil Filter

The return oil filter filters the oil in the header drive systems and should be changed after the first 50 hours of operation, and then at 500 hour intervals.

To change the return oil filter, refer to the following procedures:

- [Removing Return Oil Filter, page 419](#)
- [Installing Return Oil Filter, page 420](#)

Removing Return Oil Filter

WARNING

To avoid bodily injury or death from unexpected startup of the machine, always stop the engine and remove the key from the ignition before leaving the operator's seat for any reason.

1. Shut down the engine, and remove the key from the ignition.
2. Move platform on the left cab-forward side of machine to open position. For instructions, refer to [5.3.1 Opening Platforms – Standard Position, page 318](#).
3. Clean around head of filter (A).
4. Place a container beneath filter (A) to collect any oil that may leak out.
5. Unscrew filter (A) with a filter wrench.
6. Dispose of used oil and filter in accordance with local legislation.

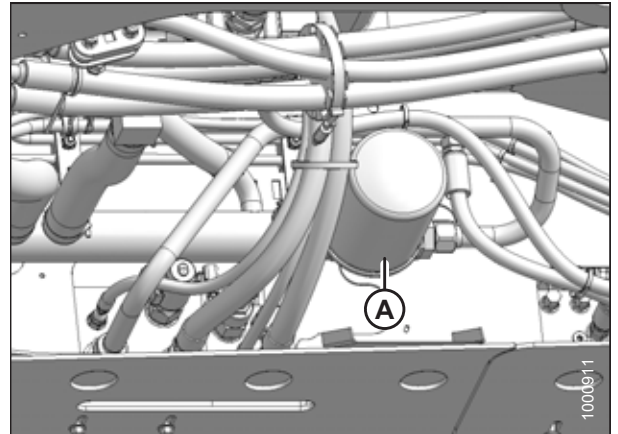

Figure 5.184: Return Oil Filter

NOTE:

Filter head removed to show component clarity.

7. Remove gasket (C) from groove (B) in filter head (A).

NOTE:

Filter (D) shown for context.

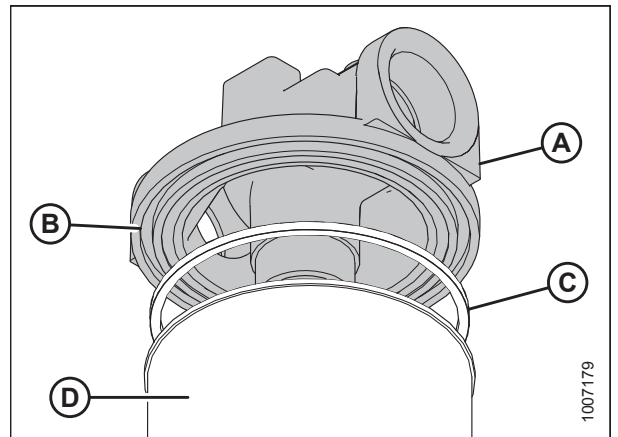

Figure 5.185: Return Oil Filter

Installing Return Oil Filter

NOTE:

For filter specifications, refer to *8.2.4 Filter Part Numbers, page 480*.

1. Clean gasket groove (B) in filter head (A). If O-ring is installed in groove, remove and discard it.
2. Apply a thin film of clean oil to the filter square cut gasket (C).
3. Install new square cut gasket (C) into groove (B) in filter head (A).
4. Screw new filter (D) onto the filter head until the gasket contacts the filter.

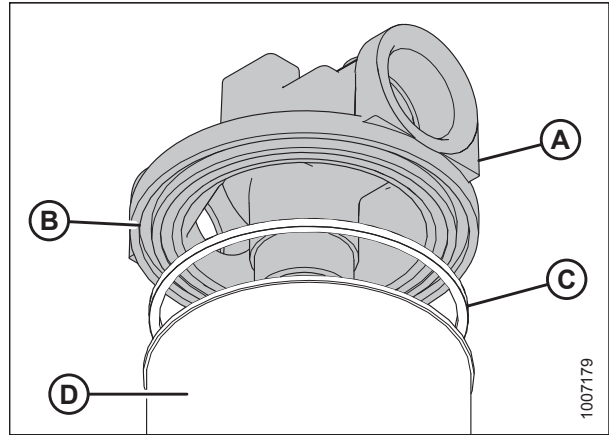

Figure 5.186: Return Oil Filter

5. Tighten filter (A) an additional 3/4 turn by hand.

IMPORTANT:

Do **NOT** use a filter wrench to install oil filter. Overtightening can damage gasket and filter.

6. Check hydraulic fluid levels. Refer to *5.10.1 Checking and Filling Hydraulic Oil, page 415*.

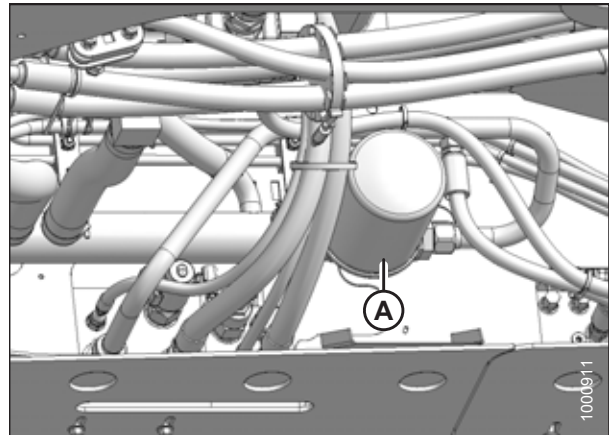

Figure 5.187: Return Oil Filter

5.10.5 Header and Reel Hydraulics

Hoses and Lines

Check hydraulic hoses and lines daily for signs of leaks.

WARNING

- Avoid high-pressure fluids. Escaping fluid can penetrate the skin causing serious injury.
- Relieve pressure before disconnecting hydraulic lines. Tighten all connections before applying pressure.
- Keep hands and body away from pin-holes and nozzles which eject fluids under high pressure.



Figure 5.188: Hydraulic Pressure Hazard

WARNING

- Use a piece of cardboard or paper to search for leaks.
- If ANY fluid is injected into the skin, it must be surgically removed within a few hours by a Doctor familiar with this type of injury or gangrene may result.

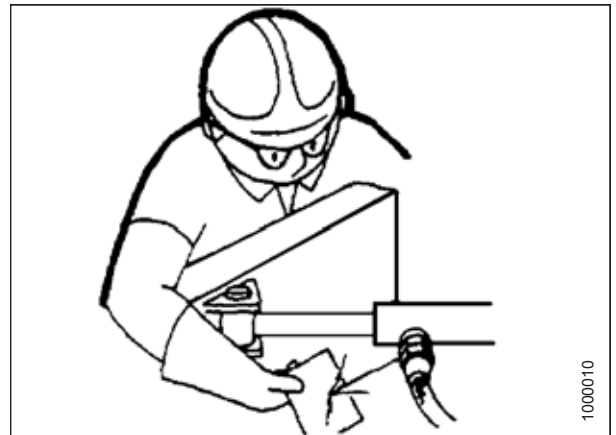

Figure 5.189: Checking Hydraulic Leaks

IMPORTANT:

- Keep hydraulic coupler tips and connectors clean. Dust, dirt, water, and foreign material are the major causes of hydraulic system damage.
- DO **NOT** attempt to service hydraulic system in the field. Precision fits require WHITE ROOM CARE during overhaul.

MAINTENANCE AND SERVICING

Pressure Compensator Valve

The pressure compensator valve protects the header drive pumps from overheating under very heavy loads.

When the operating pressure reaches the absolute pressure limit setting (refer to [5.3, page 422](#)) the compensator valve in the pump is activated and the header drive will slow down to avoid overheating the drive pumps. At this point, reduce the ground speed to maintain the correct system load and header drive operation.

NOTE:

An optional pressure sensor is available to monitor the knife or reel drive hydraulic pressure and provide a warning tone from the cab display module (CDM) if the system pressure approaches a preset limit. The system pressure limit is set during CDM programming. Refer to [7.3.7 Pressure Sensor Kit, page 464](#). The warning tone is only heard if the pressure sensor is installed and enabled.

NOTE:

A warning tone is normal when the operating pressure is close to the compensator valve's pressure setting.

Table 5.3 Header Hydraulic Pressures

Header Model	Application/System	Windrower Absolute Pressure Limit Setting kPa (psi)	Suggested Overload Warning Setting kPa (psi)
R/R1 Series	Disc pressure	28,958 (4200)	27,579 (4000)
D/D1 Series	Reel/drapper pressure	22,063 (3200)	20,684 (3000)
A Series	Knife/conditioner pressure	28,958 (4200)	27,579 (4000)

If lift and drive capacity problems develop, the pressure compensator valve may require adjusting. Contact your MacDon Dealer for assistance.

Flow Control Blocks

Two hydraulic valve blocks with multiple cartridges are used for the various windrower functions and are controlled by the windrower control module (WCM) according to the inputs from the Operator. The valve blocks are located behind the left cab-forward platform.

The valve blocks do not require any scheduled maintenance other than to check for leaking fittings or loose electrical connections. If service is required, contact your MacDon Dealer.

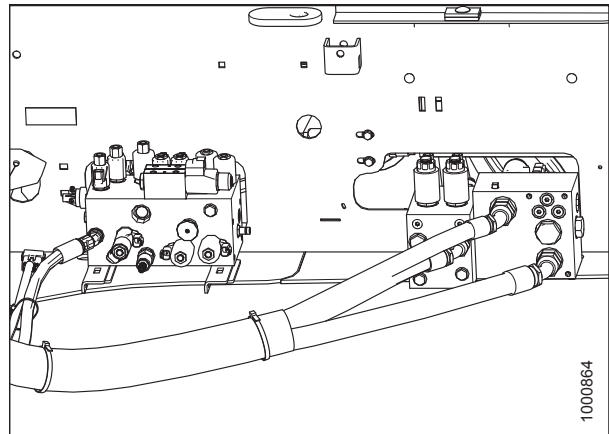

Figure 5.190: Hydraulic Valve Blocks

Adjusting Header Drop Rate

The header should lower gradually when the LOWER HEADER switch is pressed. From fully raised to ground position, it should take approximately 3–4 seconds.

IMPORTANT:

Drop rate should **NOT** be less than 3–4 seconds as structural damage may result.

NOTE:

If drop rate is too slow (over 30 seconds), return to cut height, tilt, or float presets will deactivate to prevent overheating the hydraulic system.

 **WARNING**

To avoid bodily injury or death from unexpected startup of the machine, always stop the engine and remove the key from the ignition before leaving the operator's seat for any reason.

1. Shut down the engine, and remove the key from the ignition.
2. Move platform on the left cab-forward side of machine to open position. For instructions, refer to [5.3.1 Opening Platforms – Standard Position, page 318](#).
3. Loosen inner knob (B) on needle valve, and adjust as follows:
 - Turn outer knob (A) clockwise to decrease the drop rate
 - Turn outer knob (A) counterclockwise to increase the drop rate
4. Tighten inner knob (B).
5. Check the drop rate and adjust as required.
6. Close the platform. For instructions, refer to [5.3.2 Closing Platforms – Standard Position, page 319](#).

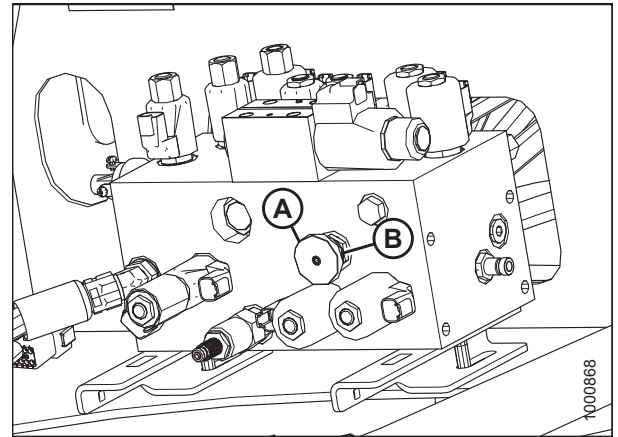

Figure 5.191: Multifunction Control Manifold

Adjusting Reel Drop Rate

When the lower reel switch is pressed, the reel should drop from fully raised to fully lowered in approximately 3–4 seconds. Drop rate is a customer preference and will vary based on crop type and cutting condition.

IMPORTANT:

Drop rate should **NOT** be less than 3–4 seconds as structural damage may result.

 **WARNING**

To avoid bodily injury or death from unexpected startup of the machine, always stop the engine and remove the key from the ignition before leaving the operator's seat for any reason.

1. Lower the header fully.
2. Shut down the engine, and remove the key from the ignition.
3. Move platform on the left cab-forward side of machine to open position. For instructions, refer to [5.3.1 Opening Platforms – Standard Position, page 318](#).

MAINTENANCE AND SERVICING

4. Locate drop rate control valve (A), installed at port D on the manifold.

NOTE:

This valve is installed on draper-ready windrowers and only affects draper headers.

5. Loosen set screw (B), then refer to the following options:
 - Turn cap (C) clockwise to decrease the drop rate.
 - Turn cap (C) counterclockwise to increase the drop rate.
6. Check the drop rate and adjust as required.

NOTE:

To reset to factory specifications, fully close the needle valve and open it four turns counterclockwise.

7. Tighten set screw (B).

NOTE:

Decal (A) is provided on frame for easy reference.

8. Close the platform. For instructions, refer to [5.3.2 Closing Platforms – Standard Position, page 319](#).

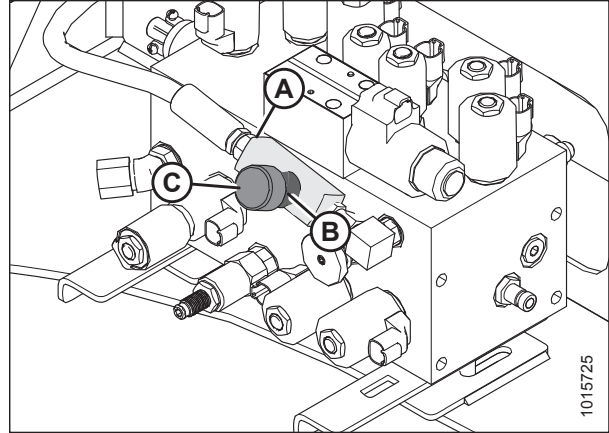

Figure 5.192: Multifunction Control Manifold

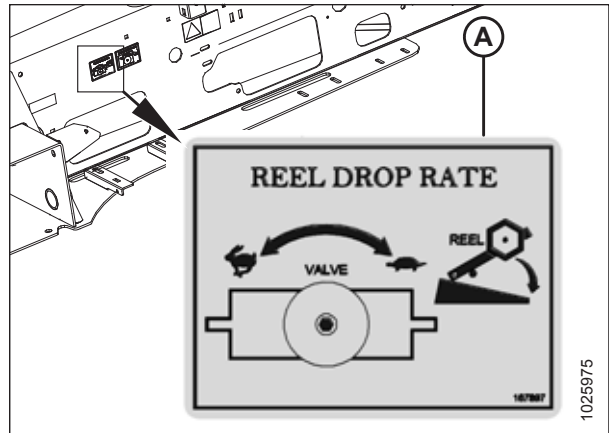

Figure 5.193: Decal

5.10.6 Traction Drive Hydraulics

The windrower transmission consists of two variable-displacement axial-piston hydraulic pumps—one for each drive wheel. The pumps are driven through a gearbox from the engine. Each pump requires charge flow in order to:

- Make up for internal leakage
- Maintain positive pressure in the main circuit
- Provide flow for cooling
- Replace any leakage losses from external valving or auxiliary systems

The charge pressure is monitored. The cab display module (CDM) sounds a tone and displays a flashing warning if charge pressure drops below 1725 kPa (250 psi). Refer to [Display Warnings and Alarms, page 85](#).

Checking Transmission Oil Pressure

IMPORTANT:

Rated charge pressure **MUST** be maintained under all conditions of operation to prevent damage to the transmission.

If the TRANS OIL PRESSURE warning is displayed, shut down the engine, and proceed as follows:

1. Check the hydraulic fluid level in the tank. Refer to *5.10.1 Checking and Filling Hydraulic Oil, page 415*.
2. Check the hoses and lines for leakage.
3. Check the charge pressure relief valve. Refer to *Checking Charge Pump Pressure, page 425*.
4. If charge pressure still cannot be maintained, do **NOT** operate the windrower. Contact your MacDon Dealer.

Checking Charge Pump Pressure

 **WARNING**

To avoid bodily injury or death from unexpected startup of the machine, always stop the engine and remove the key from the ignition before leaving the operator's seat for any reason.

Incorrect charge pressure settings may result in the inability to build required system pressure and/or inadequate loop flushing flows.

Correct charge pressure **MUST** be maintained under all conditions to maintain pump control performance and to operate the brake release.

Check charge pump pressure as follows:

1. Open hood fully. Refer to *5.2.3 Opening Hood – Highest Position, page 316*.
2. Attach a 0–4000 kPa (0–600 psi) pressure gauge to a hose that is long enough to allow pressure gauge to be read from the operator's seat.
3. Locate test port (A) on the charge filter head. Clean the test port fitting, and then attach hose to the fitting.
4. Start engine and leave at idle. Pressure should be 1655–2241 kPa (240–325 psi) with the hydraulic oil at 40°C (100°F) minimum.
5. Make note of the reading and shut down the windrower.
6. If pressure is **NOT** within this range, contact your MacDon Dealer.
7. If pressure is within range, remove the hose from the test port and close the hood. Refer to *5.2.4 Closing Hood – Highest Position, page 317*.

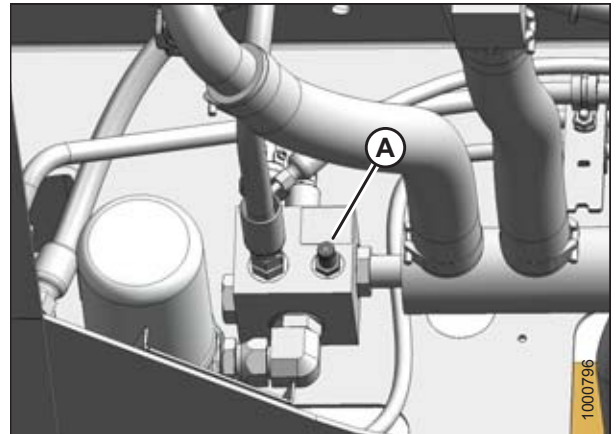

Figure 5.194: Charge Pump Test Port

5.11 Wheels and Tires

5.11.1 Traction Drive

Inflating Drive Wheel Tire

DANGER

- Use a safety cage if available.
- Do NOT stand over tire. Use a clip-on chuck and extension hose.
- NEVER install a tube in a cracked wheel rim.
- NEVER weld a wheel rim.
- Do NOT exceed maximum inflation pressure as per label on tire.
- Make sure all the air is removed from a tire before removing the tire from the rim.



Figure 5.195: Drive Tire Inflation

DANGER

- NEVER use force on an inflated or partially inflated tire. Make sure the tire is correctly seated before inflating to operating pressure.
- Do NOT remove, install, or make repairs to a tire on a rim unless you have the proper equipment and experience to perform the job. Take the tire and rim to a qualified tire repair shop.
- If the tire is NOT in the correct position on the rim or if overinflated, the tire bead can loosen on one side, causing air to leak at high speed and with great force. An air leak of this nature can thrust the tire in any direction, endangering anyone in the area.

WARNING

To avoid bodily injury or death from unexpected startup of the machine, always stop the engine and remove the key from the ignition before leaving the operator's seat for any reason.

Perform a daily visual check that the tires haven't lost pressure. Adjust the pressure as required. Underinflated drive tires can cause sidewall cracks.

Maintain tire pressure as follows:

1. Shut down the engine, and remove the key from the ignition.
2. Determine the type and size of tire that is installed on your machine.
3. Refer to the following table to determine the appropriate tire pressure:

Table 5.4 Drive Wheel Tire Options (Ten Bolt)

18.4-26 Bar	600-65 R28 Bar	18.4-26 Turf	23.1-26 Turf
317 kPa (46 psi)	241 kPa (35 psi)	317 kPa (46 psi)	234 kPa (34 psi)

MAINTENANCE AND SERVICING

- Adjust tire pressure as required.

IMPORTANT:

Check maximum inflation rating on tire sidewall. Do **NOT** exceed recommendation on tire.

Tightening Drive Wheel Nuts

Whenever a wheel is installed, retorque drive wheel nuts after 1 hour of operation. Continue with torque procedure every hour until two consecutive checks produce no movement of the nuts.

IMPORTANT:

- To avoid damage to wheel rims and studs, tighten nuts by hand. Do **NOT** use an impact gun, do **NOT** use lubricant or Never-Seez[®] compound (or equivalent), and do **NOT** overtighten wheel nuts.
- Ensure only the manufacturer's specified wheel nuts are used.

Follow these steps to tighten the drive wheel nuts:

- Tighten drive wheel nuts (A). Ensure nuts and studs are dry with **NO** lubricant or Never-Seez[®] compound (or equivalent). Torque each nut to 510 Nm (375 lbf-ft) using the tightening sequence shown at right.
- Repeat tightening sequence two additional times at specified torque.
- Repeat torque procedure every hour until two consecutive checks produce no movement of the nuts.

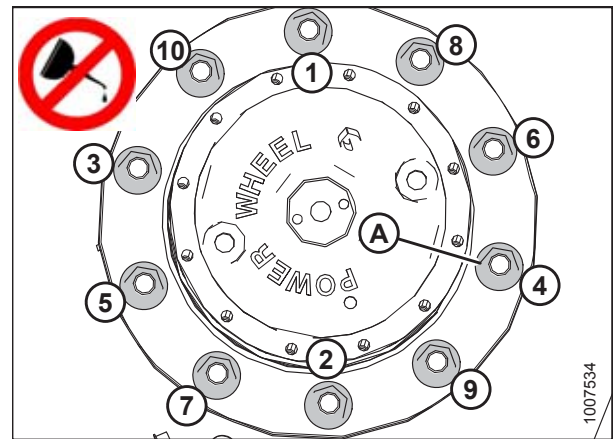

Figure 5.196: Wheel Nut Tightening Sequence

Lubricating Wheel Drive

Refer to these procedures to lubricate the wheel drive:

- [Checking Wheel Drive Lubricant Level, page 427](#)
- [Adding Wheel Drive Lubricant, page 428](#)
- [Changing Wheel Drive Lubricant, page 429](#)

Checking Wheel Drive Lubricant Level

Check the wheel drive lubricant level every 250 hours or annually.

WARNING

To avoid bodily injury or death from unexpected startup of the machine, always stop the engine and remove the key from the ignition before leaving the operator's seat for any reason.

CAUTION

Park on a flat, level surface with the header on the ground, the ground speed lever (GSL) in N-DETENT position, and the steering wheel in locked position (centered). Wait for the combine display module (CDM) to beep and display an "In Park" message to confirm the park brakes have engaged.

- Park the windrower on level ground.

MAINTENANCE AND SERVICING

2. Position windrower so plugs (A) and (B) are horizontally aligned with the hub center (C).
3. Shut down the engine, and remove the key from the ignition.
4. Remove plug (A) or (B). The lubricant should be visible through the port or running out slightly. If lubricant needs to be added, refer to [Adding Wheel Drive Lubricant, page 428](#).

NOTE:

The type of lubricant used after the first wheel drive lubricant change is not the same type of lubricant used in the factory. Refer to the manual's inside back cover for the recommended wheel drive lubricant.

5. Reinstall plugs and tighten.

Adding Wheel Drive Lubricant



WARNING

To avoid bodily injury or death from unexpected startup of the machine, always stop the engine and remove the key from the ignition before leaving the operator's seat for any reason.



CAUTION

Park on a flat, level surface with the header on the ground, the ground speed lever (GSL) in N-DETENT position, and the steering wheel in locked position (centered). Wait for the combine display module (CDM) to beep and display an "In Park" message to confirm the park brakes have engaged.

IMPORTANT:

Do **NOT** mix lubricants of different brands or characteristics.

1. Rotate the wheel drive so plugs (A) and (B) are horizontal with the center of the hub (C).
2. Stop windrower and remove key from ignition.
3. Remove the 2 plugs (A) and (B). The oil should be visible through the hole, or slightly running out.
4. If lubricant needs to be added, remove the second plug (B), and add lubricant until lubricant runs out at location (A). Refer to inside back cover.

NOTE:

The type of lubricant used after the first wheel drive lubricant change is not the same type of lubricant used in the factory. Refer to the manual's inside back cover for the recommended wheel drive lubricant.

5. Reinstall and tighten plugs (A) and (B).
6. Start up and operate the windrower for a few minutes, then stop and check the oil level. If necessary, add more oil.

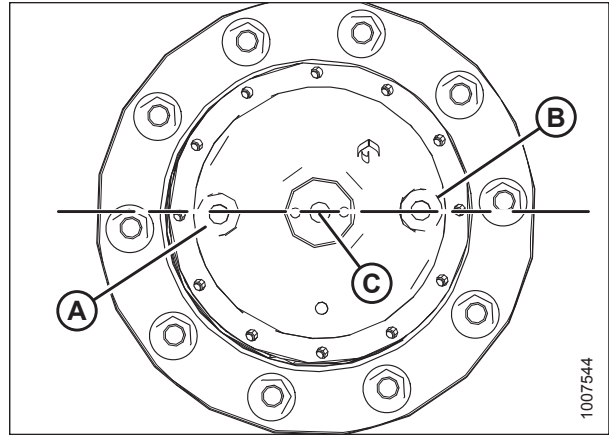

Figure 5.197: Drive Wheel Hub

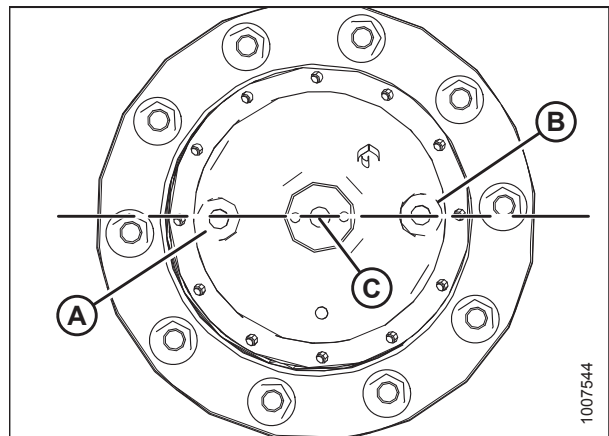

Figure 5.198: Drive Wheel Hub

Changing Wheel Drive Lubricant

The wheel drive lubricant should be changed after the first 50 hours and then changed after every 1000 hours. Change the lubricant when it is warm.

Check the level every 200 hours or annually.

WARNING

To avoid bodily injury or death from unexpected startup of the machine, always stop the engine and remove the key from the ignition before leaving the operator's seat for any reason.

CAUTION

Park on a flat, level surface with the header on the ground, the ground speed lever (GSL) in N-DETENT position, and the steering wheel in locked position (centered). Wait for the combine display module (CDM) to beep and display an "In Park" message to confirm the park brakes have engaged.

1. Park windrower on level ground and position windrower so that one of the drain plugs (A) or (B) is at the lowest point on the drive wheel hub.
2. Shut down the windrower and remove key from ignition.
3. Place a container large enough to hold at least 2 liters (2 quarts) under lower drain plug (B).
4. Remove both plugs (A) and (B), and drain lubricant into container.

CAUTION

Dispose of oil in a manner that complies with local rules and regulations.

5. After the lubricant has drained completely, start the windrower and position it so that ports (A) and (B) on wheel are level with the center of hub (C) as shown.
6. Shut down the windrower and remove the key from the ignition.
7. Add lubricant. Refer to [Adding Wheel Drive Lubricant, page 428](#).

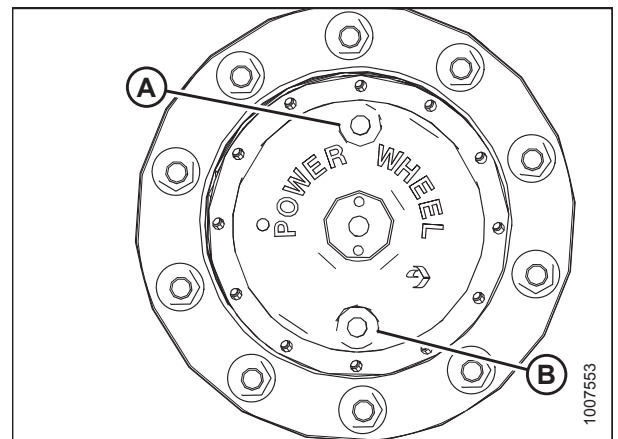

Figure 5.199: Drive Wheel Hub

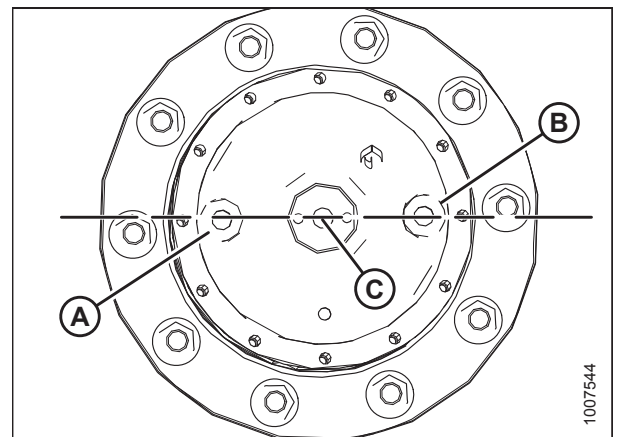

Figure 5.200: Drive Wheel Hub

Servicing Drive Wheel

To service a drive wheel, refer to the following procedures:

- *Raising Drive Wheel, page 430*
- *Removing Drive Wheel, page 431*
- *Installing Drive Wheel, page 432*
- *Lowering Drive Wheel, page 433*

Raising Drive Wheel

This procedure can be used on both drive wheels.

! WARNING

To avoid bodily injury or death from unexpected startup of the machine, always stop the engine and remove the key from the ignition before leaving the operator's seat for any reason.

! CAUTION

Header **MUST** be removed and **NO** weight box installed. Use a hydraulic jack with minimum lifting capacity of 2268 kg (5000 lb.) to provide adequate support for the machine.

1. Remove the header.
2. Park windrower on level ground and block all wheels.
3. Place ground speed lever (GSL) (A) in N-DETENT (B).
4. Shut down the engine, and remove the key from the ignition.



Figure 5.201: Ground Speed Lever

MAINTENANCE AND SERVICING

5. Place a jack under leg jack point (A), and raise the drive wheel until it is slightly off the ground. Place a jack stand beneath lift cylinder mount (B).

NOTE:

Do **NOT** place jack stand under the cylinder. Use a small metal plate on top of the jack stand.

6. Lower the windrower onto the jack stand.

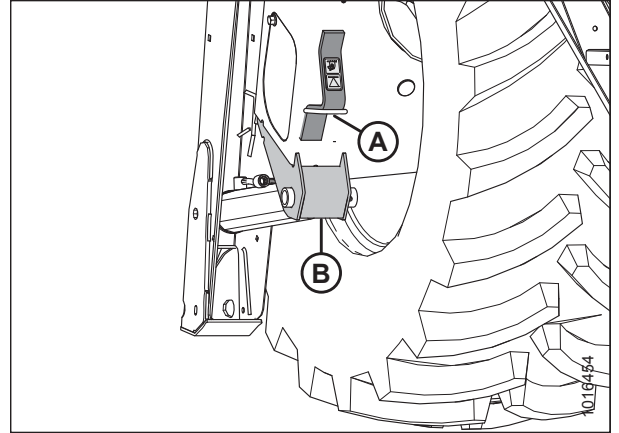

Figure 5.202: Drive Wheel Jack Point

Removing Drive Wheel

CAUTION

Use a suitable lifting device capable of supporting a minimum of 907 kg (2000 lb.) to lift the wheel assembly away from the windrower.

1. Raise windrower drive wheel (A) off the ground. Refer to [Raising Drive Wheel, page 430](#).
2. Remove wheel nuts (B).
3. Use a suitable lifting device to remove drive wheel (A).

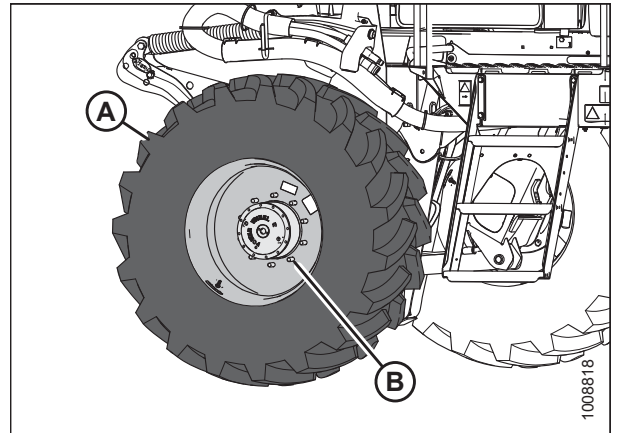

Figure 5.203: Drive Wheel

Installing Drive Wheel

CAUTION

Use a suitable lifting device capable of supporting a minimum of 907 kg (2000 lb.) to lift the wheel assembly away from the windrower.

1. Position drive wheel (A) against wheel drive hub (B) so air valve (C) is on the outside and tire tread (D) points in cab-forward direction.

NOTE:

For turf tires (diamond tread), be sure the arrow on the sidewall points in a cab-forward rotation.

2. Lift the wheel onto the hub using a suitable lifting device.
3. Remove the lifting device.

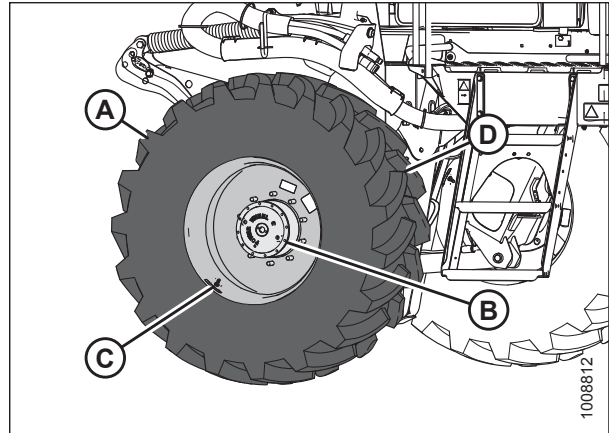

Figure 5.204: Drive Wheel

4. Line up the holes in the rim with the studs on the wheel drive hub and install wheel nuts (A).

IMPORTANT:

To avoid damaging the wheel rims and studs, tighten the nuts by hand. Do **NOT** use an impact gun, do **NOT** use lubricant or Never-Seez[®] compound, and do **NOT** overtighten the wheel nuts.

5. Torque the drive wheel nuts. For instructions, refer to [Tightening Drive Wheel Nuts, page 427](#).
6. Raise the windrower, and remove the jack. For instructions, refer to [Lowering Drive Wheel, page 433](#).

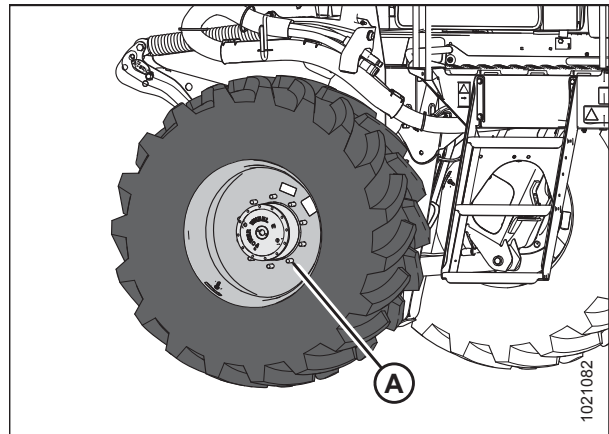

Figure 5.205: Drive Wheel Nuts

Lowering Drive Wheel

This procedure is for lowering the drive wheel when it is raised on a jack stand. This procedure can be used on both drive wheels.

CAUTION

Jack stand must be capable of supporting a minimum of 2268 kg (5000 lb.).

1. Place a jack under leg jack point (A), and raise the drive wheel slightly off the jack stand.
2. Remove the jack stand from under cylinder lift mount (B), and lower the drive wheel to the ground.
3. Remove the jack.

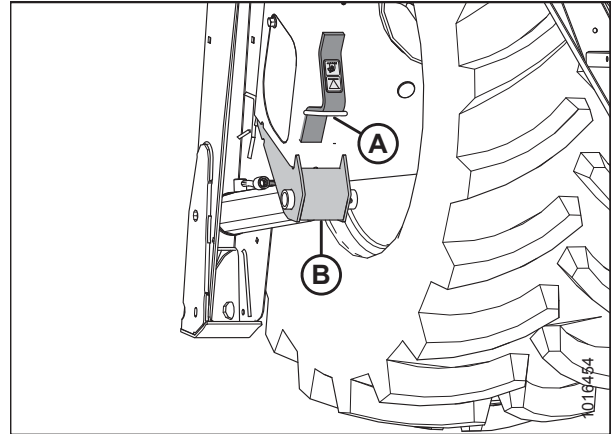

Figure 5.206: Drive Wheel Leg Jack Point

5.11.2 Caster Wheels

Inflating Caster Tire

DANGER

- Do NOT exceed maximum inflation pressure as per label on tire.
- Use a safety cage if available.
- Do NOT stand over tire. Use a clip-on chuck and extension hose.
- NEVER install a tube in a cracked wheel rim.
- NEVER weld a wheel rim.
- Make sure all the air is removed from a tire before removing the tire from the rim.

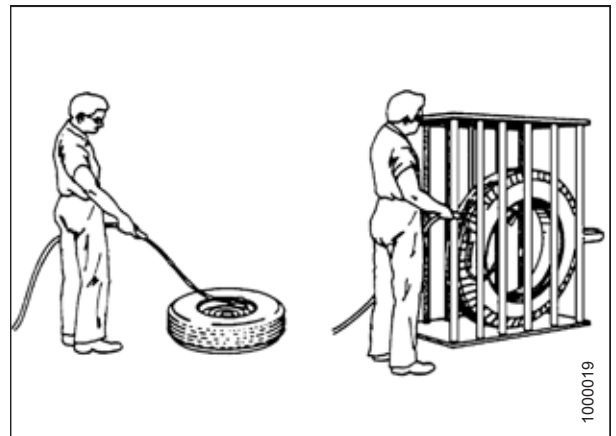

Figure 5.207: Safely Filling a Tire with Air

⚠ DANGER

- NEVER use force on an inflated or partially inflated tire. Make sure the tire is correctly seated before inflating to operating pressure.
- Do NOT remove, install, or make repairs to a tire on a rim, unless you have the proper equipment and experience to perform the job. Take the tire and rim to a qualified tire repair shop.
- If the tire is NOT in the correct position on the rim or if too full of air, the tire bead can loosen on one side, causing air to leak at high speed and with great force. An air leak of this nature can thrust the tire in any direction, endangering anyone in the area.
- To avoid severe personal injury or death caused by machine runaway, shut off engine and remove key before performing any of the following checks and/or adjustments.

Check tire pressure every year. Caster tire pressure should be 69 kPa (10 psi).

To maintain pressure, visually check daily that tires have not lost pressure, and adjust pressure as needed. Underinflation of tires can cause sidewall cracks.

NOTE:

Overinflation may cause caster wheels to shimmy.

Table 5.5 Caster Tire Options

Formed Caster	Forked Caster
7.5–16SL single rib, 10–16 front steer tire	16.5L–16.1 rib implement flotation, 10–16 front steer tire
69 kPa (10 psi)	69 kPa (10 psi)

Tightening Caster Wheel Nuts

At first use or when a wheel is removed, check wheel nut/bolt torque every 15 minutes on the road or 1 hour in the field until the specified torque is maintained.

Once specified torque is maintained, check wheel nut/bolt torque after 10 and 50 hours (field or road operation) and then at 200 hour intervals thereafter.

To tighten the caster wheel nuts on either forked or formed caster wheels, follow these steps:

1. Position wheel assembly on hub and install wheel bolts (A).
2. Tighten wheel nuts (A) to 163 Nm (120 lbf-ft) using the tightening sequence for the type of caster wheel shown in the illustrations at right. Repeat the tightening sequence three times.

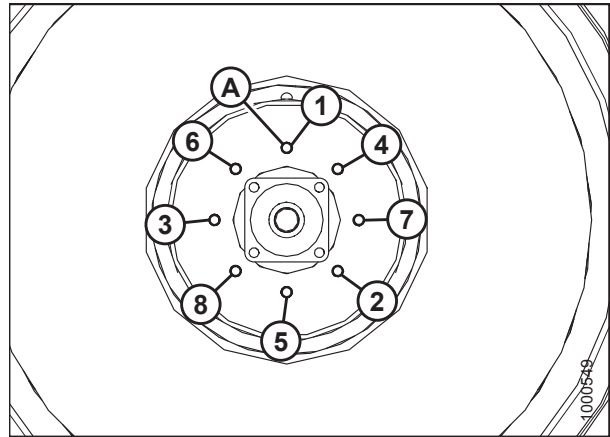

Figure 5.208: Forked Caster Wheel Nut Tightening Sequence

NOTE:

Wheel bolt (A) tightening sequence for a formed caster wheel (B) shown in Figure 5.209, page 435.

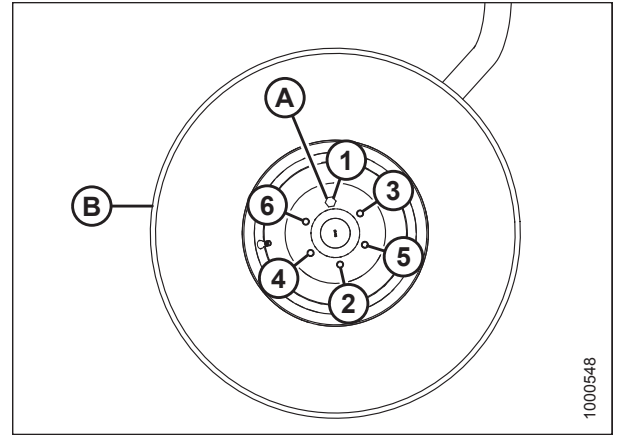

Figure 5.209: Formed Caster Wheel Nut Tightening Sequence

Servicing Caster Wheels

Refer to the following procedures:

- *Raising Caster Wheel – Formed and Forked, page 435*
- *Lowering Caster Wheel – Formed and Forked, page 437*
- *Removing Forked Caster Wheel, page 437*
- *Installing Forked Caster Wheel, page 438*
- *Removing Formed Caster Wheel, page 439*
- *Installing Formed Caster Wheel, page 439*

Raising Caster Wheel – Formed and Forked

This procedure is the same for forked and formed caster wheels.

WARNING

To avoid bodily injury or death from unexpected startup of the machine, always stop the engine and remove the key from the ignition before leaving the operator's seat for any reason.

CAUTION

Jack stand must be capable of supporting a minimum of 2268 kg (5000 lb.).

1. Park windrower on level ground and block the drive wheels.

MAINTENANCE AND SERVICING

2. Place the ground speed lever (GSL) in N-DETENT (A).
3. Shut down the engine, and remove the key from the ignition.



Figure 5.210: GSL Position

4. Raise the end of walking beam (A) until the caster wheel assembly (B) is slightly off the ground. Use a suitable lifting device, capable of lifting 2268 kg (5000 lb.) minimum.
5. Place a jack stand beneath the walking beam and lower until the beam rests on the stand.

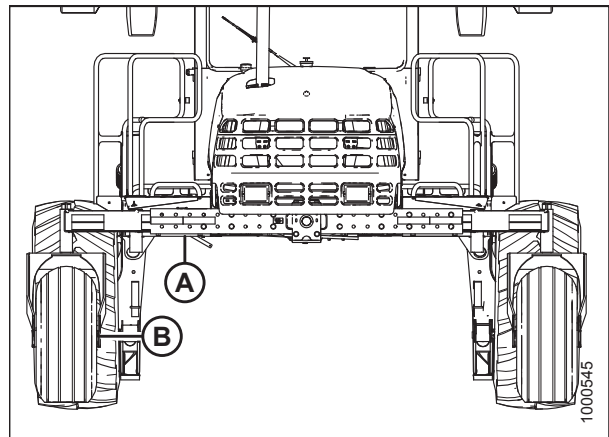

Figure 5.211: Caster Wheels and Walking Beam – Engine-Forward View

Lowering Caster Wheel – Formed and Forked

This procedure is for lowering the caster wheel when it is raised on a jack stand. This procedure is the same for forked and formed caster wheels.

CAUTION

Jack stand must be capable of supporting a minimum of 2268 kg (5000 lb.).

1. Raise the end of walking beam (A) slightly, using a suitable lifting device capable of lifting a minimum of 2268 kg (5000 lb.).
2. Remove the jack stand and lower the end of the walking beam until the caster wheel assembly (B) is on the ground.

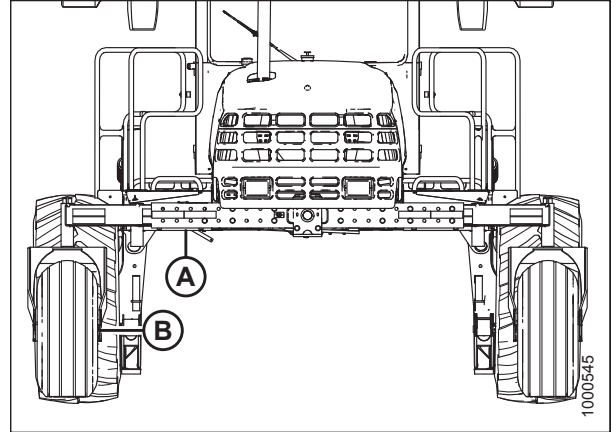

Figure 5.212: Caster Wheels and Walking Beam – Engine-Forward View

Removing Forked Caster Wheel

CAUTION

Wheel assemblies are heavy. Support wheel assembly before removing axle bolts.

1. Raise caster wheel. For instructions, refer to [Raising Caster Wheel – Formed and Forked, page 435](#).
2. Remove 8 bolts (A) (4 on each side of caster) attaching axle (B) and cover (C) to forked caster (E), and remove wheel assembly (D) from caster (E).

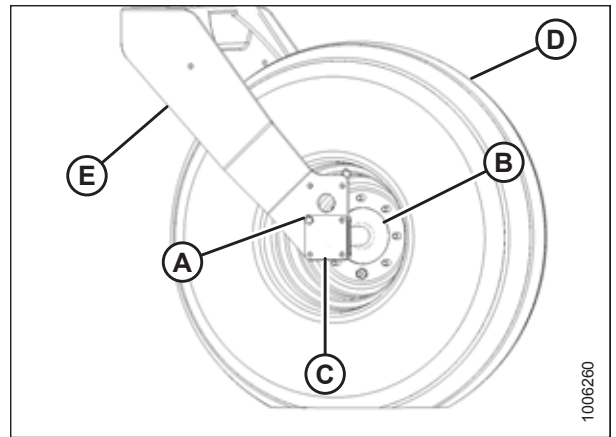

Figure 5.213: Forked Caster Wheel

MAINTENANCE AND SERVICING

3. Remove the 8 wheel nuts (A) that secure axle (B) to wheel (C).
4. Separate axle (B) and wheel (C).

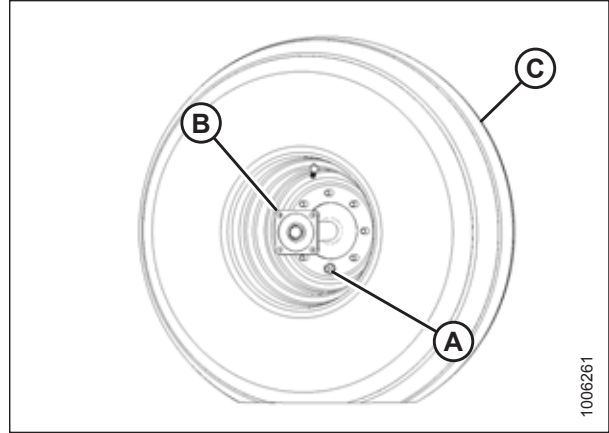

Figure 5.214: Forked Caster Wheel

Installing Forked Caster Wheel

CAUTION

Wheel assemblies are heavy. Support wheel assembly before removing axle bolts.

1. Position wheel assembly (C) on axle assembly (B) and install wheel nuts (A).
2. Torque wheel nuts (A). Refer to *Tightening Caster Wheel Nuts*, page 434.

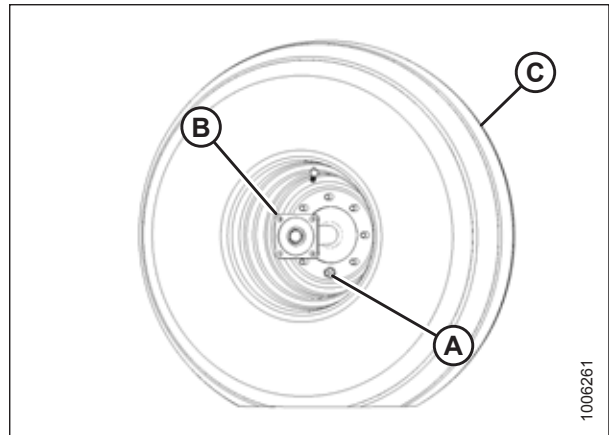

Figure 5.215: Forked Caster Wheel

3. Position wheel assembly (D) in forking caster (E).
4. Position cover plates (C) and install 8 bolts (A) (four on each side of caster) to secure axle (B) to caster (E). Torque bolts to 97–107 Nm (75–79 lbf·ft).
5. Lower caster wheel. Refer to *Lowering Caster Wheel – Formed and Forked*, page 437.

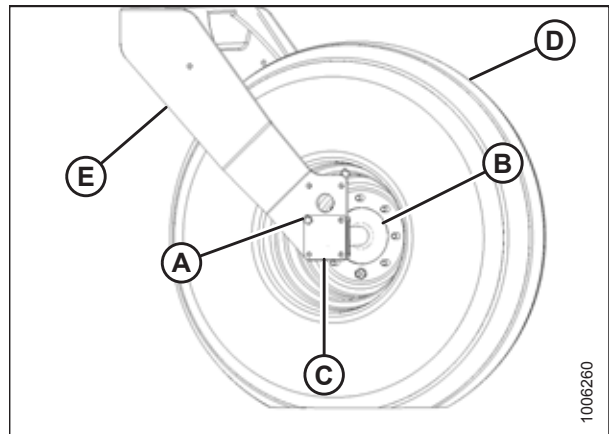

Figure 5.216: Forked Caster Wheel

Removing Formed Caster Wheel

CAUTION

Wheel assemblies are heavy. Support wheel assembly before removing axle bolts.

1. Raise caster wheel. For instructions, refer to *Raising Caster Wheel – Formed and Forked, page 435*.
2. Remove the 6 bolts (A) that secure wheel (B) to the hub.
3. Remove wheel (B).

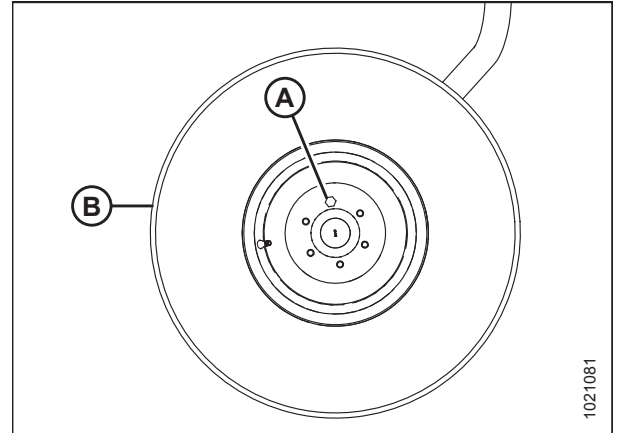

Figure 5.217: Formed Caster Wheel

Installing Formed Caster Wheel

CAUTION

Wheel assemblies are heavy. Support wheel assembly before removing axle bolts.

1. Position wheel assembly (B) on hub, and install 6 wheel bolts (A).
2. Refer to the tightening sequence at right, and torque bolts (A) to 163 Nm (120 lbf·ft).
3. Lower caster wheel. Refer to *Lowering Caster Wheel – Formed and Forked, page 437*.

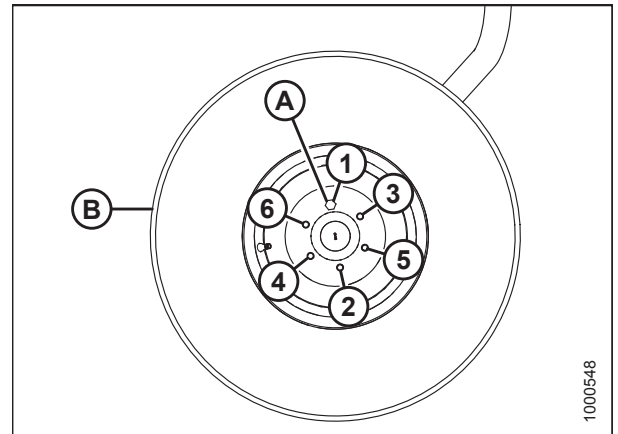

Figure 5.218: Formed Caster Wheel

MAINTENANCE AND SERVICING

Tightening Caster Wheel Anti-Shimmy Dampeners

Each caster is equipped with a fluid-filled anti-shimmy dampener (A).

The mounting bolts (B) need to be checked periodically for security. Refer to [5.12 Maintenance Schedule, page 442](#).

- Inboard bolt should be tightened to 135 Nm (100 lbf-ft)
- Outboard bolt should be tightened to 115 Nm (85 lbf-ft)

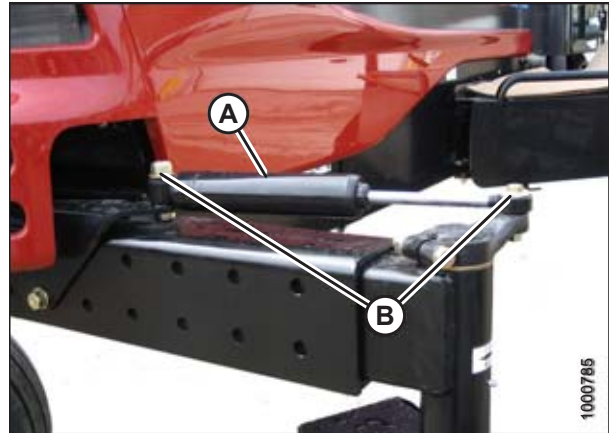

Figure 5.219: Anti-Shimmy Dampener

MAINTENANCE AND SERVICING

Ballast Requirements

Fluid ballasting of rear caster tires is recommended to provide adequate machine stability when using large headers on the windrower. The stability of the machine varies with different attachments, windrower options, terrain, and the operator’s driving technique.

Ballast capability per tire is at a maximum fill of 75%, or when fluid is level with valve stem when the stem is positioned at 12 o’clock. Fluid can be added to any level up to maximum fill. Always add an equal amount of fluid on both sides.

Table 5.6 Recommended Ballast Weight

Header Description		Recommended Ballast				Recommended Tire Size
		Level Ground		Hills		
Type	Size	Per Tire	Both Tires	Per Tire	Both Tires	
		liters (US gal)	kg (lb.) ³⁹	liters (US gal)	kg (lb.) ³⁹	
A Series	All	0				7.5 x 16 10 x 16 16.5 x 16.1
R Series	4.0 m (13 ft.) ONLY	0				7.5 x 16 10 x 16 16.5 x 16.1
D Series	7.6 m (25 ft.) and smaller	0				7.5 x 16 10 x 16 16.5 x 16.1
D Series	9.1 m (30 ft.) single or double reel without conditioner 10.7 m (35-ft.) single reel	0	0	38 (10)	91 (200)	7.5 x 16 10 x 16 16.5 x 16.1
D Series	9.1 m (30 ft.) double reel steel fingers and conditioner 10.7 m (35 ft.) double reel (5 or 6-bat)	69 (18)	170 (380)	115 (30)	288 (630)	Level ground: 10 x 16 Level ground: 16.5 x 16.1 Hills: 16.5 x 16.1
D Series	12.1 m (40 ft.)	115 (30)	288 (630)	158 (41)	377 (830)	16.5 x 16.1

39. Weights are given for typical calcium chloride and water mixtures. Weight is reduced by 20% if only water is used (for areas that do **not** require antifreeze protection).

5.12 Maintenance Schedule

The Maintenance Schedule specifies the recommended periodic maintenance procedures and service intervals. Regular maintenance is the best insurance against early wear and untimely breakdowns. Follow this schedule to maximize machine life.

For detailed instructions, refer to the various procedures in this chapter. Use the fluids and lubricants specified in [8.2 Recommended Fuel, Fluids, and Lubricants, page 478](#).

Service Intervals: The recommended service intervals are in hours of operation. Where a service interval is given in more than one time frame, for example 100 hours or annually, service the machine at whichever interval is reached first.

IMPORTANT:

Recommended intervals are for average conditions. Service the machine more often if operated under adverse conditions (severe dust, extra heavy loads, etc.).



CAUTION

Carefully follow safety messages given in [1 Safety, page 1](#).

5.12.1 Maintenance Schedule/Record

Windrower Serial Number: _____

Combine this record with the record in the header operator’s manual. Make copies of this page to continue the record.

	Hour meter reading																		
	Service date																		
	Serviced by																		
First use		Preseason or Annual. For instructions, refer to 4.3.3 Preseason Checks / Annual Service, page 161 .																	
Action		✓ Check	☼ Lubricate	▲ Change	☼ Clean														
First Hour ⁴⁰																			
✓	Drive wheel nuts. For instructions, refer to Tightening Drive Wheel Nuts, page 427 .																		
First 5 Hours ⁴⁰																			
✓	A/C compressor belt. For instructions, refer to Tensioning Air Conditioner Compressor Belt, page 379 .																		
✓	Caster wheel nuts. For instructions, refer to Tightening Caster Wheel Nuts, page 434 .																		
✓	Caster wheel anti-shimmy dampener bolts. For instructions, refer to Tightening Caster Wheel Anti-Shimmy Dampeners, page 440 .																		
✓	Walking beam width adjustment bolts. For instructions, refer to 4.3.7 Adjusting Caster Tread Width, page 178 .																		
First 10 Hours ⁴⁰																			
✓	Walking beam width adjustment bolts. For instructions, refer to 4.3.7 Adjusting Caster Tread Width, page 178 .																		
✓	Neutral adjustment ⁴¹ .																		
Every 10 Hours or Daily ⁴⁰																			
☼	A/C condenser ⁴² . For instructions, refer to Cleaning Cooler Box Components, page 372 .																		
☼	Charge air cooler. For instructions, refer to Cleaning Cooler Box Components, page 372 .																		

40. Begins from first use of machine.

41. Dealer adjusted.

42. A record of daily maintenance is not normally required but is at the Owner/Operator’s discretion.

MAINTENANCE AND SERVICING

✓	Engine oil level ⁴² . For instructions, refer to <i>Checking Engine Oil Level, page 341</i> .																		
✓	Engine coolant level. For instructions, refer to ⁴² <i>Checking Coolant Level, page 365</i> .																		
✓	Fuel tank ⁴² . For instructions, refer to <i>Filling the Fuel Tank, page 166</i> .																		
✓	Fuel filter water trap ⁴² . For instructions, refer to <i>Removing Water from Fuel System, page 362</i> .																		
✱	Hydraulic oil cooler ⁴² . For instructions, refer to <i>5.10.2 Hydraulic Oil Cooler, page 416</i> .																		
✓	Hydraulic oil level ⁴² . For instructions, refer to <i>5.10.1 Checking and Filling Hydraulic Oil, page 415</i> .																		
✱	Radiator ⁴² . For instructions, refer to <i>Maintaining Engine Cooling Box, page 369</i> .																		
✓	Tire inflation ⁴² . For instructions, refer to <i>Inflating Drive Wheel Tire, page 426</i> .																		
First 50 Hours⁴³																			
✓	Hose clamps: intake/radiator/heater/hydraulic ⁴⁴ . Refer to specific hose clamp section for instructions.																		
✓	Walking beam, with adjustment bolts. For instructions, refer to <i>4.3.7 Adjusting Caster Tread Width, page 178</i> .																		
✓	Caster wheel anti-shimmy dampener bolts (if installed). For instructions, <i>Tightening Caster Wheel Anti-Shimmy Dampeners, page 440</i> .																		
▲	Main gearbox oil. For instructions, refer to <i>Changing Lubricant, page 376</i> .																		
▲	Drive wheel lubricant. For instructions, refer to <i>Changing Wheel Drive Lubricant, page 429</i> .																		
▲	Charge system oil filter. For instructions, refer to <i>Charge Oil Filter, page 417</i> .																		
▲	Return oil filter. For instructions, refer to <i>Return Oil Filter, page 418</i> .																		

43. Begins from first use of machine.
 44. Hand-tighten unless otherwise noted.

MAINTENANCE AND SERVICING

Every 50 Hours													
✱	Cab fresh air intake filter. For instructions, refer to <i>Inspecting and Cleaning Fresh Air Filter Element, page 333.</i>												
●	Caster pivots. For instructions, refer to <i>5.4.2 Lubrication Points, page 324.</i>												
●	Forked caster spindle bearings. For instructions, refer to <i>5.4.2 Lubrication Points, page 324.</i>												
✓	Gearbox oil level. For instructions, refer to <i>Checking Lubricant Level and Adding Lubricant, page 375.</i>												
●	Top lift link pivots. For instructions, refer to <i>5.4.2 Lubrication Points, page 324.</i>												
●	Walking beam center pivot												
Annually ^{45 46}													
✓	A/C blower. For instructions, refer to <i>Air Conditioning Compressor Coolant Cycling, page 161.</i>												
✓	Antifreeze concentration. For instructions, refer to <i>Checking Engine Coolant Strength, page 365.</i>												
✓	Battery charge. For instructions, refer to <i>Maintaining Batteries, page 382.</i>												
✓	Battery fluid level. For instructions, refer to <i>Charging the Batteries, page 383.</i>												
▲	Fuel tank vent line filter. For instructions, refer to <i>Replacing Fuel Tank Vent Filter, page 353.</i>												
✓	Steering linkages. For instructions, refer to <i>Checking Steering Link Pivots, page 328.</i>												
Every 100 Hours or Annually ^{47 46}													
✱	Cab air return filter. For instructions, refer to <i>Cleaning Return Air Cleaner/Filter, page 335.</i>												
✓	Cab suspension limit straps. For instructions, refer to <i>5.6 Cab Suspension Limit Straps, page 331.</i>												

45. Begins from first use of machine.

46. It is recommended that annual maintenance be done prior to start of operating season.

47. Whichever occurs first, begins from first use of machine.

MAINTENANCE AND SERVICING

Every 250 Hours or Annually ^{47 46}													
▲	Engine oil and filter. For instructions, refer to <i>Changing Engine Oil, page 343</i> .												
▲	Engine air cleaner primary filter element. For instructions, refer to <i>Removing Primary Air Filter, page 346</i> and <i>Installing Primary Air Filter, page 348</i> .												
◆	Formed caster wheel hub bearings. For instructions, refer to <i>5.4.2 Lubrication Points, page 324</i> .												
✓	Drive wheel lubricant. For instructions, refer to <i>Checking Wheel Drive Lubricant Level, page 427</i> .												
Every 500 Hours or Annually ^{48 49}													
▲	Fuel filters. For instructions, refer to <i>Maintaining Fuel Filters, page 354</i> .												
▲	Gearbox lubricant. For instructions, refer to <i>Changing Lubricant, page 376</i> .												
▲	Charge system and return oil filters. For instructions, refer to <i>5.10.4 Changing Hydraulic Oil Filters, page 417</i> .												
✓	Safety systems. For instructions, refer to <i>5.5.2 Safety Systems, page 325</i> .												
Every 1000 Hours													
▲	Drive wheel lubricant. For instructions, refer to <i>Changing Wheel Drive Lubricant, page 429</i> .												
1500 Hours or Every Two Years ⁴⁸													
▲	Hydraulic oil. For instructions, refer to <i>5.10.3 Changing the Hydraulic Oil, page 416</i> .												
▲	Engine crank case filter. For instructions, refer to <i>Replacing Engine Oil Filter, page 344</i> .												
5000 hours or every two years ⁴⁸													
✓	Engine valve tappet clearance.												

48. Begins from first use of machine.

49. It is recommended that annual maintenance be done prior to start of operating season.

Chapter 6: Troubleshooting

6.1 Engine Troubleshooting

Problem	Solution	Reference
Symptom: Engine hard to start or will not start		
Controls not in NEUTRAL	Move GSL to NEUTRAL.	<i>Starting the Engine, page 162</i>
Controls not in NEUTRAL	Move steering wheel to locked position.	<i>Starting the Engine, page 162</i>
Controls not in NEUTRAL	Disengage header drive switch.	<i>4.4.4 Header Drive, page 206</i>
NEUTRAL Interlock misadjusted	Contact Dealer.	Contact Dealer
No fuel to engine	Fill empty fuel tank. Replace clogged filter.	<i>Filling the Fuel Tank, page 166 and Maintaining Fuel Filters, page 354</i>
Old fuel in tank	Drain tank. Refill with fresh fuel.	<i>5.8.5 Fuel System, page 353</i>
Water, dirt, or air in fuel system	Drain, flush, fill, and prime system.	<i>5.8.5 Fuel System, page 353</i>
Improper type of fuel	Use proper fuel for operating conditions.	<i>8.2.2 Fuel Specifications, page 478</i>
Crankcase oil too heavy	Use recommended oil.	<i>8.2.3 Lubricants, Fluids, and System Capacities, page 479</i>
Low battery output	Have battery tested. Check battery electrolyte level.	<i>5.9.2 Battery, page 382</i>
Poor battery connection	Clean and tighten loose connections.	<i>5.9.2 Battery, page 382</i>
Faulty starter	Contact Dealer.	Contact Dealer
Loose electrical connection at fuel pump	Ensure connector at pump is fully pushed in.	Contact Dealer
Wiring shorted, circuit breaker open	Check continuity of wiring and breaker (manual reset).	<i>Checking and Replacing Fuses, page 410</i>
ECM fuse (1 of 2) blown	Replace.	<i>Checking and Replacing Fuses, page 410</i>
ECM Ignition relay faulty	Replace.	<i>Checking and Replacing Fuses, page 410</i>
NEUTRAL Logic relay faulty	Replace.	<i>Checking and Replacing Fuses, page 410</i>
Faulty injectors	Contact Dealer.	Contact Dealer
Symptom: Engine knocks		
Engine out of time	Contact Dealer.	Contact Dealer
Insufficient oil	Add oil.	<i>Adding Engine Oil, page 344</i>
Low or high coolant temperature	Contact Dealer.	Contact Dealer
Improper fuel	Use proper fuel.	<i>8.2.2 Fuel Specifications, page 478</i>

TROUBLESHOOTING

Problem	Solution	Reference
Symptom: Low oil pressure		
Low oil level	Add oil.	<i>Adding Engine Oil, page 344</i>
Improper type of oil	Drain and fill crankcase with proper oil.	<i>8.2.3 Lubricants, Fluids, and System Capacities, page 479</i>
Worn components	Contact Dealer.	Contact Dealer
Symptom: High oil consumption		
Internal parts worn	Contact Dealer.	Contact Dealer
Crankcase oil too light	Use recommended oil.	<i>8.2.3 Lubricants, Fluids, and System Capacities, page 479</i>
Oil leaks	Check for leaks around gaskets, seals, and drain plugs.	<i>Checking Engine Oil Level, page 341</i>
Symptom: Engine runs irregularly or stalls frequently		
Unsteady fuel supply	Change filter on fuel tank vent line. Replace clogged fuel filter.	<i>Replacing Fuel Tank Vent Filter, page 353 and 5.8.5 Fuel System, page 353</i>
Water or dirt in fuel system	Drain, flush, and fill fuel system.	<i>8.2.3 Lubricants, Fluids, and System Capacities, page 479</i>
Low coolant temperature	Remove and check thermostat.	Contact Dealer
Air in fuel system	Contact Dealer.	Contact Dealer
Dirty or faulty injectors	Contact Dealer.	Contact Dealer
Symptom: Lack of power		
Incorrect timing	Contact Dealer.	Contact Dealer
Engine oil viscosity too high	Use recommended oil.	<i>8.2.3 Lubricants, Fluids, and System Capacities, page 479</i>
Intake air restriction	Service air cleaner.	<i>5.8.4 Engine Air Intake System, page 345</i>
Clogged fuel filter	Replace primary fuel filter, and if necessary, replace secondary fuel filter.	<i>Maintaining Fuel Filters, page 354</i>
High back pressure	Clean out or replace muffler.	<i>5.8.8 Exhaust System, page 377</i>
Improper type of fuel	Use proper fuel.	<i>8.2.2 Fuel Specifications, page 478</i>
High or low engine temperature	Remove and check thermostat.	Contact Dealer
Improper valve clearance	Contact Dealer.	Contact Dealer
Faulty injectors	Contact Dealer.	Contact Dealer
Symptom: Engine temperature below normal		
Defective thermostat	Remove and check thermostat.	Contact Dealer

TROUBLESHOOTING

Problem	Solution	Reference
Symptom: Warning alarm sounds		
Engine overheated	Check coolant level.	<i>Checking Coolant Level, page 365</i>
Engine overheated	Check thermostat.	Contact Dealer
Low engine oil pressure	Check oil level.	<i>Checking Engine Oil Level, page 341</i>
Low transmission oil pressure	Check oil level.	<i>5.10.1 Checking and Filling Hydraulic Oil, page 415</i>
Symptom: Engine overheats		
Low coolant level	Fill reserve tank to proper level. Check system for leaks.	<i>5.8.6 Engine Cooling System, page 364</i>
Water only for coolant	Replace with antifreeze.	<i>5.8.6 Engine Cooling System, page 364</i>
Engine overloaded	Reduce ground speed.	<i>Driving Forward in Cab-Forward Mode, page 172</i>
Defective radiator cap	Replace cap.	<i>Inspecting Radiator Cap, page 364</i>
Defective fan belt	Replace belt.	<i>Replacing Fan Belt, page 377</i>
Dirty radiator screen, rotors turning	Check for obstructions in ducting from screen to fan shroud.	<i>Maintaining Engine Cooling Box, page 369</i>
Dirty radiator screen, rotors not turning	Check connections to rotor electric motor.	<i>Maintaining Engine Cooling Box, page 369</i>
Dirty radiator core	Clean radiator.	<i>5.8.6 Engine Cooling System, page 364</i>
Cooling system dirty	Flush cooling system.	<i>5.8.6 Engine Cooling System, page 364</i>
Defective thermostat	Remove and check thermostat.	Contact Dealer
Defective temperature gauge or sender	Check coolant temperature with thermometer. Replace gauge if necessary.	Contact Dealer
Defective water pump	Contact Dealer.	Contact Dealer
Symptom: High fuel consumption		
Clogged or dirty air cleaner	Service air cleaner.	<i>5.8.4 Engine Air Intake System, page 345</i>
Engine overloaded	Reduce ground speed.	<i>Driving Forward in Cab-Forward Mode, page 172</i>
Improper valve clearance	Contact Dealer.	Contact Dealer
Engine out of time	Contact Dealer.	Contact Dealer
Dirty injector nozzles	Contact Dealer.	Contact Dealer
Low engine temperature	Check thermostat.	Contact Dealer
Improper type of fuel	Use proper fuel.	<i>8.2.2 Fuel Specifications, page 478</i>

TROUBLESHOOTING

Problem	Solution	Reference
Symptom: Engine emits black or grey exhaust		
Improper type of fuel	Consult your fuel supplier, and use proper type fuel for conditions.	8.2.2 Fuel Specifications, page 478
Engine overloaded	Reduce ground speed.	Driving Forward in Cab-Forward Mode, page 172
Clogged or dirty air cleaner	Service air cleaner.	Cleaning Engine Air Filter Primary Element, page 350
Defective muffler	Check muffler for possible damage that might create back pressure.	5.8.8 Exhaust System, page 377
Dirty or faulty injectors	Contact Dealer.	Contact Dealer
Engine out of time	Contact Dealer.	Contact Dealer
Air in fuel system	Contact Dealer.	Contact Dealer
Symptom: Engine emits white exhaust		
Engine out of time	Contact Dealer.	Contact Dealer
Improper type of fuel	Consult your fuel supplier, and use proper type fuel for conditions.	8.2.2 Fuel Specifications, page 478
Cool engine	Warm engine up to normal operating temperature.	Engine Warm-Up, page 164
Defective thermostat	Remove and check thermostat.	Contact Dealer
Symptom: Starter cranks slowly or will not operate		
Low battery output	Check battery charge.	Maintaining Batteries, page 382
Loose or corroded battery connections	Clean and tighten loose connections.	Maintaining Batteries, page 382
Controls not in NEUTRAL	Move GSL to NEUTRAL.	Driving Forward in Cab-Forward Mode, page 172
Controls not in NEUTRAL	Move steering wheel to CENTER position.	Driving Reverse in Cab-Forward Mode, page 173
Controls not in NEUTRAL	Disengage header.	Engaging and Disengaging the Header, page 206
Relay not functioning	Check relay and wire connections.	5.9 Electrical System, page 381
Main fuse defective/blown	Replace main fuse.	5.9 Electrical System, page 381
Key power fuse blown	Replace key power fuse.	5.9 Electrical System, page 381
Key switch worn or terminals loose	Contact Dealer.	Contact Dealer
Switch at Interlock not closed or defective	Adjust switch or replace. Contact your Dealer.	Contact Dealer
Crankcase oil too high viscosity	Use recommended oil.	8.2.3 Lubricants, Fluids, and System Capacities, page 479
Symptom: Air filters require frequent cleaning		
Aspirator plugged	Clean out aspirator.	5.8.4 Engine Air Intake System, page 345

TROUBLESHOOTING

6.2 Electrical Troubleshooting

Problem	Solution	Reference
Symptom: Low voltage and/or battery will not charge		
Defective battery	Have battery tested.	<i>5.9.2 Battery, page 382</i>
Loose or corroded connections	Clean and tighten battery connections.	<i>Maintaining Batteries, page 382</i>
Defective alternator belt	Replace worn belt.	<i>Replacing Fan Belt, page 377</i>
Alternator or voltage regulator not connected properly	Connect properly.	<i>5.9.2 Battery, page 382</i>
Dirty or defective alternator, defective voltage regulator, or high resistance in circuit	Contact Dealer.	Contact Dealer
Symptom: Lights dim		
Defective light switch	Contact Dealer.	Contact Dealer
High resistance in circuit or poor ground on lights	Check the wiring circuit for a break in a wire or a poor ground.	—
Symptom: Lights do not light		
Burned out or defective light bulb	Replace light bulb.	<i>Replacing Headlight Bulb, page 390</i>
Burned out or defective light bulb	Replace light bulb.	<i>Replacing Bulb in Cab-Forward Flood Light, page 397</i>
Burned out or defective light bulb	Replace light bulb.	<i>Replacing Bulb in Rear Flood Light, page 403</i>
Broken wiring	Check wiring for broken wire or shorts.	—
Poor ground on lights	Clean and tighten ground wires.	—
Open or defective circuit breaker	Check circuit breaker.	<i>Accessing Circuit Breakers and Fuses, page 409</i>
Defective relay	Replace relay.	<i>Replacing Circuit Breakers and Relays, page 410</i>
Defective light switch	Contact Dealer.	Contact Dealer
Symptom: Turn signals or indicators showing wrong direction		
Reversed wires	Contact Dealer.	Contact Dealer
Symptom: No current to cab		
Broken or disconnected wire	Contact Dealer.	Contact Dealer
Circuit breaker tripped	Breaker automatically resets.	—
Battery disconnect switch is OFF	Turn battery disconnect switch ON.	<i>Battery Main Disconnect Switch, page 382</i>

TROUBLESHOOTING

6.3 Hydraulics Troubleshooting

Problem	Solution	Reference
Symptom: Header or reel not lifting		
Appropriate solenoids not being energized by activating switch	Contact Dealer.	Contact Dealer
Contaminant in relief valve	Clean relief valve at cylinder control valve.	Contact Dealer
Relief pressure too low or contaminant in relief valve	Check/adjust/clean relief valve at cylinder control valve.	Contact Dealer
Symptom: Reel and/or conveyor not turning		
HEADER DRIVE switch not engaged	Engage HEADER DRIVE switch.	<i>Engaging and Disengaging the Header, page 206</i>
Flow controls adjusted too low	Toggle speed controls on CDM to increase flow.	D Series and D1 SP Series: <i>4.6.6 Draper Speed, page 294</i> , and <i>4.6.5 Reel Speed, page 291</i> A Series: <i>4.7.1 Auger Speed, page 303</i>
Appropriate solenoid on flow control block not being energized	Contact Dealer.	Contact Dealer
Symptom: Reel and/or conveyor turns but lacks power		
Relief pressure too low	Check/adjust/clean relief valve.	Contact Dealer
Symptom: Hydraulic oil high-temperature alarm		
Hydraulic oil cooling system not working properly	Check/clean cooling box.	<i>Maintaining Engine Cooling Box, page 369</i>
Faulty bypass valve	Clean or replace bypass valve.	Contact Dealer
Symptom: Hydraulic oil low-temperature alarm		
Hydraulic oil too cold	Run engine until hydraulic oil warms up.	—
Symptom: Header or reel lifts unevenly		
Air in system	Fully raise header or reel and hold switch.	<i>4.4.1 Engaging and Disengaging Header Safety Props, page 196</i>

6.4 Header Drive Troubleshooting

Problem	Solution	Reference
Symptom: Header drive not engaging		
HEADER DRIVE switch in cab not engaged	Engage HEADER DRIVE switch.	<i>Engaging and Disengaging the Header, page 206</i>
Operator Presence switch not closed or faulty	Occupy operator's seat or replace switch. Contact your Dealer.	Contact Dealer
Appropriate solenoid not being energized by activating switch	Contact Dealer.	Contact Dealer
Symptom: Header drive lacks power		
Relief valve setting too low	Contact Dealer.	Contact Dealer
Hydraulic couplers/unions not properly connected	Ensure hoses are connected correctly and hose couplers/unions are tight.	Refer to the header operator's manual.
Header drive overload	Reduce ground speed.	—
Symptom: Warning alarm sounds		
Header drive overload	Reduce ground speed.	—
Relief valve setting too low	Contact Dealer.	Contact Dealer

6.5 Traction Drive Troubleshooting

Problem	Solution	Reference
Symptom: Warning alarm sounds and transmission oil light is on		
Low hydraulic oil level	Stop engine, and add oil to hydraulic system.	5.10.1 Checking and Filling Hydraulic Oil, page 415
Low hydraulic pressure	Contact Dealer.	Contact Dealer
Foreign material shorting sender	Contact Dealer.	Contact Dealer
Short in alarm wiring	Contact Dealer.	Contact Dealer
Faulty sender	Contact Dealer.	Contact Dealer
Symptom: Wheels lack pulling ability on a grade or pulling out of a ditch		
Internal pump or motor damage	Contact Dealer.	Contact Dealer
Insufficient torque at drive wheels	Move ground speed range control to field position, and reduce ground speed.	Driving Forward in Engine-Forward Mode, page 174
Loose or worn controls	Check controls.	5.5.3 Ground Speed Lever Adjustments, page 327
Air in system	Use proper oil.	8.2.3 Lubricants, Fluids, and System Capacities, page 479
Air in system	Check oil level and leaks.	5.10.1 Checking and Filling Hydraulic Oil, page 415
Air in system	Check hydraulic oil filters.	5.10 Hydraulic System, page 414
Brakes binding or not releasing fully	Check pressure on brake release valve (min. 1379 kPa [200 psi]).	Contact Dealer
Relief valve in tandem pump dirty or damaged	Replace relief valve.	Contact Dealer
Symptom: With steering wheel centered, one wheel pulls more than the other		
Leakage at pump or motor	Contact Dealer.	Contact Dealer
Wheels not in same speed range	Contact Dealer.	Contact Dealer
Faulty relief valve	Repair or replace valve. Contact Dealer.	Contact Dealer
Symptom: Both wheels will not pull in forward or reverse		
Pump arms have broken shaft or loose hardware	Repair or tighten parts and hardware.	Contact Dealer
Brakes binding or not releasing fully	Check pressure on brake release valve (min. 1379 kPa [200 psi]).	Contact Dealer
Low oil level	Check oil reservoir level.	5.10.1 Checking and Filling Hydraulic Oil, page 415
Power hubs disengaged	Engage final drives.	Engaging and Disengaging Final Drives, page 194
Damaged hydraulic lines preventing proper oil flow	Replace damaged lines.	Contact Dealer
Ground speed range control not working	Contact Dealer.	Contact Dealer

TROUBLESHOOTING

Problem	Solution	Reference
Steering controls worn or defective	Check GSL and steering for loose, worn, or damaged ball joints and connecting rods.	5.5.3 Ground Speed Lever Adjustments, page 327 and 5.5.4 Steering Adjustments, page 328
Charge pressure relief valve misadjusted or damaged	Check the valve adjustment. Check valve parts and seat.	Checking Charge Pump Pressure, page 425
Failed pump or motor	Contact Dealer.	Contact Dealer
Symptom: One wheel does not pull in forward or reverse		
Broken pump arm or shaft	Contact Dealer.	Contact Dealer
One final drive disengaged	Engage final drive.	Engaging and Disengaging Final Drives, page 194
Steering controls worn or defective	Check GSL and steering for loose, worn, or damaged ball joints and connecting rods.	5.5.3 Ground Speed Lever Adjustments, page 327 and 5.5.4 Steering Adjustments, page 328
High pressure relief valve stuck open, damaged seat	Check valve, and clean or replace.	Contact Dealer
Brakes binding or not releasing fully	Check pressure on brake release valve (min. 1379 kPa [200 psi]).	Contact Dealer
Damaged hydraulic lines preventing proper oil flow	Contact Dealer.	Contact Dealer
Ground speed range control not working	Contact Dealer.	Contact Dealer
Failed pump, motor, or power hub	Contact Dealer.	Contact Dealer
Symptom: Excessive noise from drive system		
Mechanical interference in steering or ground speed linkage	Adjust, repair, and replace.	5.5.3 Ground Speed Lever Adjustments, page 327 and 5.5.4 Steering Adjustments, page 328
Brakes binding or not releasing fully	Check pressure on brake release valve (min. 1379 kPa [200 psi]).	Contact Dealer
Faulty pump or motor	Contact Dealer.	Contact Dealer
Air in system	Check lines for leakage.	—
Hydraulic line clamps loose	Tighten clamps.	—
Symptom: Hydraulic oil filter leaks at seal		
Not properly tightened	Tighten filter element.	5.10.4 Changing Hydraulic Oil Filters, page 417
Damaged seal or threads	Replace filter or filter head.	5.10.4 Changing Hydraulic Oil Filters, page 417

6.6 Steering and Ground Speed Control Troubleshooting

Problem	Solution	Reference
Symptom: Machine will not steer straight		
Linkage worn or loose	Adjust steering chain tension. Replace worn parts. Adjust linkage.	<i>5.5.4 Steering Adjustments, page 328</i>
Symptom: Machine moves on flat ground with controls in neutral		
Neutral interlock misadjusted	Contact Dealer.	Contact Dealer
Parking brake not functioning	Contact Dealer.	Contact Dealer
GSL servo misadjusted	Contact Dealer.	Contact Dealer
GSL cable misadjusted	Contact Dealer.	Contact Dealer
Transmission interlock misadjusted	Contact Dealer.	Contact Dealer
Symptom: Steering wheel will not unlock		
Transmission interlock cylinder not working	Contact Dealer.	Contact Dealer
Symptom: Insufficient road speed		
Ground speed range control in field position	Move to road position.	<i>Driving on the Road, page 180</i>
Symptom: Steering is too stiff or too loose		
Steering chain tension is out of adjustment	Adjust steering chain tension.	<i>5.5.4 Steering Adjustments, page 328</i>

6.7 Cab Air Troubleshooting

Problem	Solution	Reference
Symptom: Blower fan will not run		
Burned out motor	Contact Dealer.	Contact Dealer
Burned out switch	Contact Dealer.	Contact Dealer
Motor shaft tight or bearings worn	Contact Dealer.	Contact Dealer
Faulty wiring—loose or broken	Contact Dealer.	Contact Dealer
Blower rotors in contact with housing	Contact Dealer.	Contact Dealer
Symptom: Blower fan operating but no air coming into cab		
Dirty fresh air filter	Clean fresh air filter.	<i>Inspecting and Cleaning Fresh Air Filter Element, page 333</i>
Dirty recirculating air filter	Clean recirculating filter.	<i>Cleaning Return Air Cleaner/ Filter, page 335</i>
Evaporator clogged	Clean evaporator.	<i>Cleaning Air Conditioning Evaporator Core, page 337</i>
Air flow passage blocked	Remove blockage.	—
Symptom: Heater not heating		
Heater shut-off valve at engine closed	Open valve.	<i>3.10.1 Heater Shut-Off, page 56</i>
Defective thermostat in engine water outlet manifold	Replace thermostat.	Contact Dealer
Heater temperature control defective	Replace control.	Contact Dealer
No thermostat in engine water outlet manifold	Install thermostat.	Contact Dealer
Symptom: Odor from air louvers		
Plugged drainage hose	Blow out hose with compressed air.	—
Dirty filters	Clean filters.	<i>Cleaning Return Air Cleaner/ Filter, page 335</i>
Symptom: Air conditioning not cooling		
Low refrigerant level	Add refrigerant. Contact Dealer.	Contact Dealer
Clutch coil burned out or disconnected	Contact Dealer.	Contact Dealer
Blower motor disconnected or burned out	Contact Dealer.	Contact Dealer
Switch contacts in thermostat burned excessively, or sensing element defective	Replace thermostat.	Contact Dealer.
Compressor partially or completely seized	Remove compressor for service or replacement.	Contact Dealer.
Condenser fins plugged	Clean condenser.	<i>5.7.3 Air Conditioning Condenser, page 336</i>

TROUBLESHOOTING

Problem	Solution	Reference
Loose or broken compressor drive belt	Replace drive belt and/or tighten to specifications.	<i>Tensioning Air Conditioner Compressor Belt, page 379 and Replacing Air Conditioner Compressor Belt, page 379</i>
Dirty filters	Clean fresh air and recirculation filters.	<i>Cleaning Engine Air Filter Primary Element, page 350 and Cleaning Return Air Cleaner/Filter, page 335</i>
Broken or disconnected electrical wire	Check all terminals for loose connections; check wiring for hidden breaks.	—
Broken or disconnected ground wire	Check ground wire to see if the wire is loose, broken, or disconnected.	—
Expansion valve stuck in open or closed position	Contact Dealer.	Contact Dealer
Broken refrigerant line	Contact Dealer.	Contact Dealer
Leak in system	Contact Dealer.	Contact Dealer
Compressor shaft seal leaking	Contact Dealer.	Contact Dealer
Clogged screen in receiver-drier; plugged hose or coil	Contact Dealer.	Contact Dealer
Symptom: Air conditioning not producing sufficient cooling⁵⁰		
Compressor clutch slipping	Remove clutch assembly for service or replacement.	Contact Dealer
Thermostat defective or improperly adjusted	Replace thermostat.	Contact Dealer
Clogged air filters	Remove air filters, and clean or replace as necessary.	<i>Cleaning Engine Air Filter Primary Element, page 350 and Cleaning Return Air Cleaner/Filter, page 335</i>
Heater circuit is open	Close temperature control in cab, and valve on engine.	<i>3.10.3 Climate Controls, page 57 and 3.10.1 Heater Shut-Off, page 56</i>
Insufficient air circulation over condenser coil; fins clogged with dirt or insects	Clean condenser.	<i>5.7.3 Air Conditioning Condenser, page 336</i>
Evaporator fins clogged	Clean evaporator fins (under cab floor).	<i>Cleaning Air Conditioning Evaporator Core, page 337</i>
Refrigerant low	Contact Dealer.	Contact Dealer
Clogged expansion valve	Contact Dealer.	Contact Dealer
Clogged receiver-drier	Contact Dealer.	Contact Dealer
Excessive moisture in system	Contact Dealer.	Contact Dealer

50. Sufficient cooling defined as when air temperature in cab, measured at louvered vent, can be maintained at 14°C (25°F) below ambient air temperature.

TROUBLESHOOTING

Problem	Solution	Reference
Air in system	Contact Dealer.	Contact Dealer
Blower motor sluggish in operation	Contact Dealer.	Contact Dealer
Symptom: Air conditioning cools intermittently		
Unit icing up due to thermostat adjusted too low	Adjust thermostat.	Contact Dealer
Unit icing up due to excessive moisture in system	Contact Dealer.	Contact Dealer
Unit icing up due to incorrect super-heat adjustment in the expansion valve	Contact Dealer.	Contact Dealer
Thermostat defective	Contact Dealer.	Contact Dealer
Defective blower switch or blower motor	Contact Dealer.	Contact Dealer
Partially open, improper ground or loose connection in compressor clutch coil	Contact Dealer.	Contact Dealer
Compressor clutch slipping	Contact Dealer.	Contact Dealer
Symptom: Air conditioning system too noisy		
Defective winding or improper connection in compressor clutch coil or relay	Contact Dealer.	Contact Dealer
Excessive charge in system	Contact Dealer.	Contact Dealer
Low charge in system	Contact Dealer.	Contact Dealer
Excessive moisture in system	Contact Dealer.	Contact Dealer
Loose or excessively worn drive belt	Tighten or replace as required.	<i>Tensioning Air Conditioner Compressor Belt, page 379 and Replacing Air Conditioner Compressor Belt, page 379</i>
Noisy clutch	Remove clutch for service or replacement as required.	Contact Dealer
Noisy compressor	Check mountings and repair. Remove compressor for service or replacement.	Contact Dealer
Compressor oil level low	Add SP-15 PAG refrigerant oil.	Contact Dealer
Blower fan noisy due to excessive wear	Remove blower motor for service or replacement as necessary.	Contact Dealer
Symptom: Windows fog up		
High humidity	Run A/C to dehumidify air and heater to control temperature.	<i>3.10.3 Climate Controls, page 57</i>

6.8 Operator's Station Troubleshooting

Problem	Solution	Reference
Symptom: Rough ride		
Seat suspension not adjusted for operator's weight	Adjust seat suspension.	<i>3.3 Operator's Seat Adjustments, page 42</i>
High air pressure in tires	Deflate to proper pressure.	<i>Inflating Drive Wheel Tire, page 426 and Inflating Caster Tire, page 433</i>
Cab suspension too stiff	Adjust suspension.	Contact Dealer

Chapter 7: Options and Attachments

The following options and attachments are available through your MacDon Dealer. The Dealer will require the part number (MD #) to determine pricing and availability.

7.1 Cab

7.1.1 AM/FM Radio

The cab is pre-wired for easy installation of a single DIN audio component available from your MacDon Dealer. Speakers are factory-installed.

In order to retain radio settings and preset memory with the battery disconnect turned off, select a radio with non-volatile memory.

For installation details, refer to the unloading and assembly instructions supplied with your windrower.

7.1.2 Automated Steering Systems

A MacDon-approved automated steering system is available from MacDon Dealers that provide Trimble® global positioning system (GPS) installation and support services.

MacDon windrowers are partially pre-wired for either the Trimble® AutoPilot™ hydraulically integrated steering system or the Trimble® EZ-Pilot® wheel/column-based assisted steering system. The windrower's ground speed lever (GSL) has an automated steering (autosteer) engage switch and the Trimble® display mounting kit (MD #183348) is supplied in the cab.

The Trimble® AutoPilot™ system requires the MacDon automated steering hydraulic interface kit (MD #B5589). Installation instruction (MD #169539) is included in the bundle.

Other GPS providers may supply parts in their vehicle-specific installation packages or make installation kits available through MacDon Dealers.

7.1.3 High Intensity Discharge Auxiliary Lighting

This kit includes two cab-mounted high intensity discharge (HID) lamps that provide additional field lighting.

MD #B5596

Instruction MD #169621 is included in the bundle.

7.1.4 Warning Beacons

This kit includes two rotating warning beacons designed for installation onto the pre-wired cab, a switch, mounting hardware, and instructions. The beacons are standard equipment for exported windrowers, and are optional for North America. Fits model year 2009 and newer machines.

MD #B5582

Instruction MD #169538 is included in the bundle.

7.1.5 Windshield Shades

This kit includes retractable sun shades for front and rear windows. Attachment hardware is also included in the kit.

MD #B4866

Instruction MD #169218 is included in the bundle.

7.2 Engine

7.2.1 Engine Block Heater

Contact your nearest Cummins Engine Distributor, and provide your engine model and serial numbers to ensure the proper heater is supplied.

7.2.2 Engine Fan Air Baffle

The Engine Fan Air Baffle kit prevents the windrow from being disturbed by engine cooling fan air blast.

MD #B5440

Instruction MD #169443 is included in the bundle.

7.3 Header Operation

7.3.1 Draper Header Case Drain Kit

The Draper Header Case Drain kit must be installed when attaching a MacDon D50, D60, or D65 Draper Header with an upper cross auger (UCA), without double-draper drive. Case Drain kit (MD #B5842) is **NOT** required for double-draper drive headers equipped with kits MD #B5606 and MD #B6154.

MD #B5842

7.3.2 Draper Header Reel Drive and Lift Plumbing

This base kit is required to run a draper header. It includes draper header reel drive and lift plumbing (less valve) and reel fore-aft hydraulics.

NOTE:

If the last digit of windrower code is B, this bundle is already installed.

MD #B5577

Instruction MD #169537 is included in the bundle.

7.3.3 Header Drive Reverser

This kit allows the conditioner, knife, auger, and reel to reverse on the auger header, and the conditioner and knife to reverse on the draper header.

MD #B4656 ^{51, 52, 53, 54}

Instruction MD #169213 is included with the bundle.

-
51. If installed on a windrower equipped with a D Series Draper Header, only the knife circuit will reverse.
 52. If installed on a windrower equipped with an A Series Auger Header, the knife, reel, auger, and conditioner will reverse. Grass seed auger headers are not equipped with conditioners.
 53. If installed on a windrower equipped with a D Series Draper Header and HC10 Hay Conditioner, knife and conditioner will reverse.
 54. R Series Disc Headers cannot use the reversing feature.

7.3.4 Hydraulic Center-Link

Allows remote adjustment of the header angle using a hydraulic cylinder between the header and the windrower.

- MD #B4650 (hydraulic center-link)
- Instruction MD #169236 is included in the bundle
- MD #B5269 (auxiliary valve)
- Instruction MD #169271 is included in the bundle

7.3.5 Light Header Flotation

This kit is available for headers that do not require as much spring tension for header float.

MD #B4664

Instruction MD #169033 is included in the bundle.

7.3.6 Mechanical Center-Link

The mechanical center-link provides a manually adjustable connection between the windrower and the header/mower conditioner.

MD #B4665

7.3.7 Pressure Sensor Kit

This kit provides enhanced monitoring of the knife drive (or reel drive) hydraulic pressure, and warns of overload conditions.

MD #B5574

Instruction MD #169031 is included in the bundle.

7.3.8 R1 Disc Drive Kit

This kit includes a valve required to run an R1 Series Rotary Disc Header on an M155 SP Windrower.

MD #B4657

7.3.9 R80 and R85 Rotary Header Drive Hydraulics – 4.0 m (13 ft.)

This kit is required to allow operation of a 4.0 m (13 ft.) R80 or R85 Rotary Disc Header. The kit includes header drive plumbing and installation instructions.

MD #B5510

Instructions are included in the bundle.

MD #169544 4.0 m (13 ft.) R80 and R85 attached to M150, M155, or M155E4

7.3.10 Self-Aligning Center-Link

This kit allows the center-link cylinder to be hydraulically positioned and connected to the header without leaving the operator's station.

Hydraulic center-link (MD #B4650) must be installed.

MD #B4802

Instruction MD #169004 included in the bundle.

7.3.11 Spring with External Booster Spring

This kit is available for headers over 2724 kg (6000 lb.) to increase float capacity.

The Spring with External Booster Spring kit (MD #B4659) includes two springs (one for each side) and mounting brackets.

Instruction MD #169032 is included in the bundle.

7.3.12 Spring with Internal Booster Spring

MacDon windrowers have two large diameter springs on each side—one is the outboard spring, and the other is the inboard spring. This kit (MD #B5303) replaces ONE of the large-diameter springs (that does not already have an inner booster spring installed) with a new inboard spring assembly that comes with an internal booster spring inside.

The Spring with Internal Booster Spring kit (MD #B5303) includes one spring and castings for one side of the windrower.

Instruction MD #169316 is included in the bundle.

7.3.13 Swath Compressor

The MacDon Swath Compressor is a large, formed polyethylene sheet which is designed to mount to the underside of a MacDon M Series Self-Propelled Windrower. The MacDon Swath Compressor is designed for use with D Series Draper Headers cutting canola.

When lowered, the swath compressor helps prevent wind damage by shaping the windrow and anchoring it into the stubble behind the header using a smooth, gradual transition that helps prevent shelling in ripe conditions.

The Swath Compressor height is adjusted using a rocker switch on the operator's console and monitored on the Cab Display Module (CDM).

MD #C2061

Instructions MD #214752 and MD #214732 are included.

7.3.14 Swath Roller

An axle-mounted swath roller increases the windrow's resistance to wind disturbance, especially in canola or similar crops. It can be fitted with a hydraulic lift with in-cab controls.

Contact your MacDon Dealer for information.

7.4 Transport

7.4.1 Lighting and Marking for Cab-Forward Road Travel

This kit allows the windrower to be compliant with vehicle lighting regulations when travelling in the cab-forward mode on public roads. The kit includes red taillights, slow moving vehicle (SMV) markings, hardware, and installation instructions.

MD #B5412

Instruction MD #169426 is included in the bundle.

7.4.2 Towing Harness

The towing harness is used together with the weight box (refer to [7.4.3 Weight Box, page 466](#)) when towing a D Series Draper Header equipped with slow speed transport option behind the windrower.

MD #B5280 – Weight box harness only. Includes hitch pin and wiring for use with slow speed header transport option.

Instruction MD #169278 is included in the bundle.

7.4.3 Weight Box

A weight box installed onto the windrower header lift system is required to transport a header behind the windrower.

MD #B5238 – Weight box without harness

A towing harness is required to use the weight box. Refer to [7.4.2 Towing Harness, page 466](#) for more information.

Chapter 8: Reference

8.1 Recommended Torques

8.1.1 Torque Specifications

The following tables provide correct torque values for various bolts, cap screws, and hydraulic fittings.

- Tighten all bolts to torque values specified in charts (unless otherwise noted throughout this manual).
- Replace hardware with same strength and grade of bolt.
- Use torque value tables as a guide and periodically check tightness of bolts.
- Understand torque categories for bolts and cap screws by using their identifying head markings.

Jam nuts

When applying torque to finished jam nuts, multiply the torque applied to regular nuts by $f=0.65$.

Self-tapping screws

Standard torque is to be used (**NOT** to be used on critical or structurally important joints).

SAE Bolt Torque Specifications

Torque values shown in following tables are valid for non-greased, or non-oiled threads and heads; therefore, do **NOT** grease or oil bolts or cap screws unless otherwise specified in this manual.

Table 8.1 SAE Grade 5 Bolt and Grade 5 Free Spinning Nut

Nominal Size (A)	Torque (Nm)		Torque (lbf·ft) (*lbf·in)	
	Min.	Max.	Min.	Max.
1/4-20	11.9	13.2	*106	*117
5/16-18	24.6	27.1	*218	*241
3/8-16	44	48	32	36
7/16-14	70	77	52	57
1/2-13	106	118	79	87
9/16-12	153	170	114	126
5/8-11	212	234	157	173
3/4-10	380	420	281	311
7/8-9	606	669	449	496
1-8	825	912	611	676

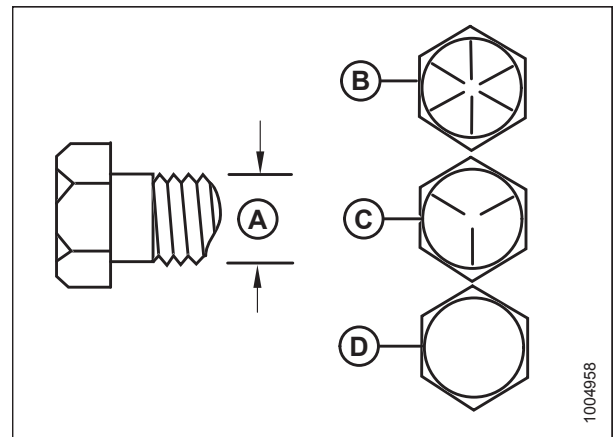

Figure 8.1: Bolt Grades

A - Nominal Size
C - SAE-5

B - SAE-8
D - SAE-2

REFERENCE

Table 8.2 SAE Grade 5 Bolt and Grade F Distorted Thread Nut

Nominal Size (A)	Torque (Nm)		Torque (lbf-ft) (*lbf-in)	
	Min.	Max.	Min.	Max.
1/4-20	8.1	9	*72	*80
5/16-18	16.7	18.5	*149	*164
3/8-16	30	33	22	24
7/16-14	48	53	35	39
1/2-13	73	80	54	59
9/16-12	105	116	77	86
5/8-11	144	160	107	118
3/4-10	259	286	192	212
7/8-9	413	456	306	338
1-8	619	684	459	507

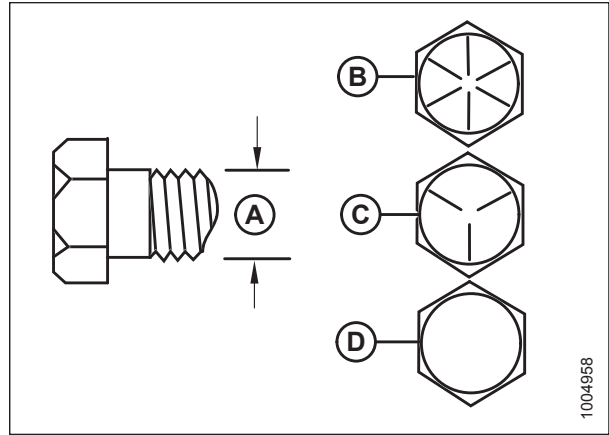

Figure 8.2: Bolt Grades

A - Nominal Size
 B - SAE-8
 C - SAE-5
 D - SAE-2

Table 8.3 SAE Grade 8 Bolt and Grade G Distorted Thread Nut

Nominal Size (A)	Torque (Nm)		Torque (lbf-ft) (*lbf-in)	
	Min.	Max.	Min.	Max.
1/4-20	16.8	18.6	*150	*165
5/16-18	24	26	18	19
3/8-16	42	46	31	34
7/16-14	67	74	50	55
1/2-13	102	113	76	84
9/16-12	148	163	109	121
5/8-11	204	225	151	167
3/4-10	362	400	268	296
7/8-9	583	644	432	477
1-8	874	966	647	716

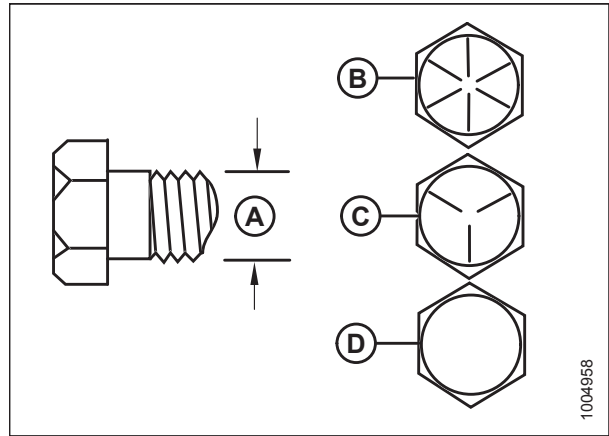

Figure 8.3: Bolt Grades

A - Nominal Size
 B - SAE-8
 C - SAE-5
 D - SAE-2

REFERENCE

Table 8.4 SAE Grade 8 Bolt and Grade 8 Free Spinning Nut

Nominal Size (A)	Torque (Nm)		Torque (lbf-ft) (*lbf-in)	
	Min.	Max.	Min.	Max.
1/4-20	16.8	18.6	*150	*165
5/16-18	35	38	26	28
3/8-16	61	68	46	50
7/16-14	98	109	73	81
1/2-13	150	166	111	123
9/16-12	217	239	160	177
5/8-11	299	330	221	345
3/4-10	531	587	393	435
7/8-9	855	945	633	700
1-8	1165	1288	863	954

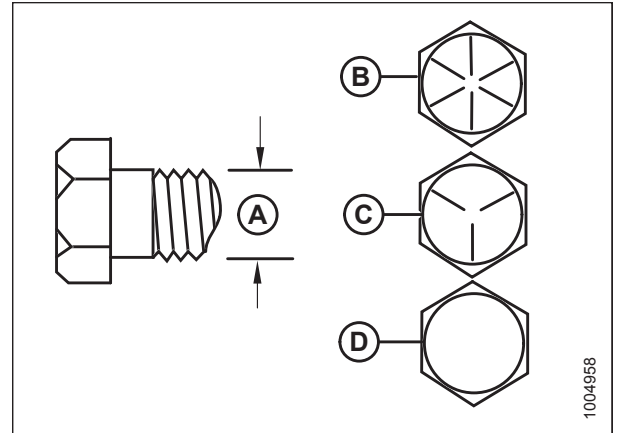

Figure 8.4: Bolt Grades

A - Nominal Size
C - SAE-5

B - SAE-8
D - SAE-2

Metric Bolt Specifications

Table 8.5 Metric Class 8.8 Bolts and Class 9 Free Spinning Nut

Nominal Size (A)	Torque (Nm)		Torque (lbf-ft) (*lbf-in)	
	Min.	Max.	Min.	Max.
3-0.5	1.4	1.6	*13	*14
3.5-0.6	2.2	2.5	*20	*22
4-0.7	3.3	3.7	*29	*32
5-0.8	6.7	7.4	*59	*66
6-1.0	11.4	12.6	*101	*112
8-1.25	28	30	20	23
10-1.5	55	60	40	45
12-1.75	95	105	70	78
14-2.0	152	168	113	124
16-2.0	236	261	175	193
20-2.5	460	509	341	377
24-3.0	796	879	589	651

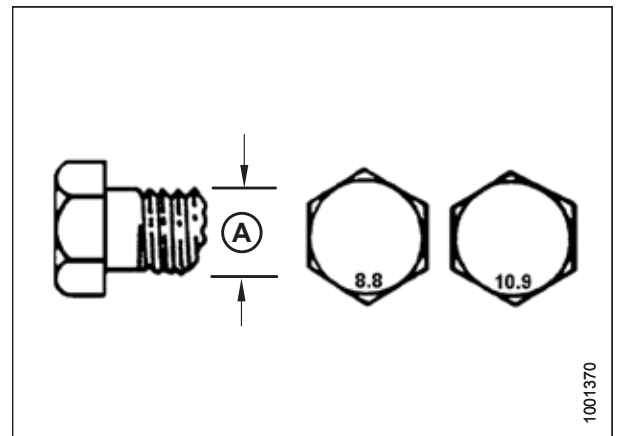

Figure 8.5: Bolt Grades

REFERENCE

Table 8.6 Metric Class 8.8 Bolts and Class 9 Distorted Thread Nut

Nominal Size (A)	Torque (Nm)		Torque (lbf-ft) (*lbf-in)	
	Min.	Max.	Min.	Max.
3-0.5	1	1.1	*9	*10
3.5-0.6	1.5	1.7	*14	*15
4-0.7	2.3	2.5	*20	*22
5-0.8	4.5	5	*40	*45
6-1.0	7.7	8.6	*69	*76
8-1.25	18.8	20.8	*167	*185
10-1.5	37	41	28	30
12-1.75	65	72	48	53
14-2.0	104	115	77	85
16-2.0	161	178	119	132
20-2.5	314	347	233	257
24-3.0	543	600	402	444

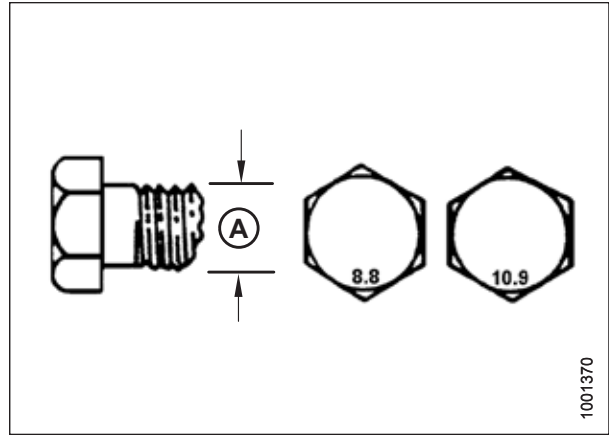

Figure 8.6: Bolt Grades

Table 8.7 Metric Class 10.9 Bolts and Class 10 Free Spinning Nut

Nominal Size (A)	Torque (Nm)		Torque (lbf-ft) (*lbf-in)	
	Min.	Max.	Min.	Max.
3-0.5	1.8	2	*18	*19
3.5-0.6	2.8	3.1	*27	*30
4-0.7	4.2	4.6	*41	*45
5-0.8	8.4	9.3	*82	*91
6-1.0	14.3	15.8	*140	*154
8-1.25	38	42	28	31
10-1.5	75	83	56	62
12-1.75	132	145	97	108
14-2.0	210	232	156	172
16-2.0	326	360	242	267
20-2.5	637	704	472	521
24-3.0	1101	1217	815	901

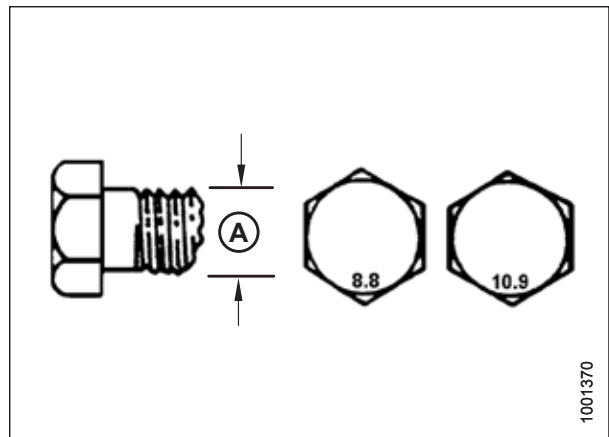

Figure 8.7: Bolt Grades

REFERENCE

Table 8.8 Metric Class 10.9 Bolts and Class 10 Distorted Thread Nut

Nominal Size (A)	Torque (Nm)		Torque (lbf-ft) (*lbf-in)	
	Min.	Max.	Min.	Max.
3-0.5	1.3	1.5	*12	*13
3.5-0.6	2.1	2.3	*19	*21
4-0.7	3.1	3.4	*28	*31
5-0.8	6.3	7	*56	*62
6-1.0	10.7	11.8	*95	*105
8-1.25	26	29	19	21
10-1.5	51	57	38	42
12-1.75	90	99	66	73
14-2.0	143	158	106	117
16-2.0	222	246	165	182
20-2.5	434	480	322	356
24-3.0	750	829	556	614

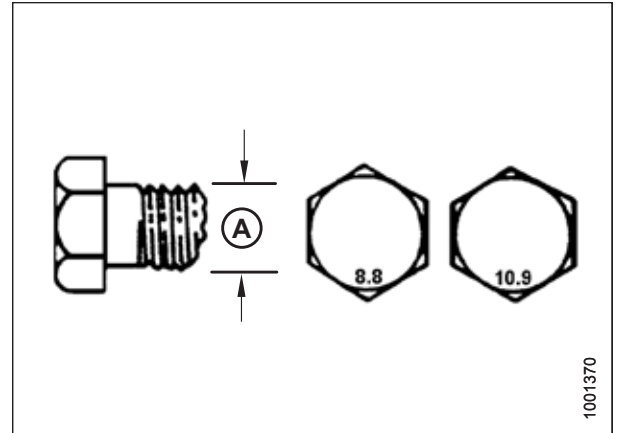

Figure 8.8: Bolt Grades

Metric Bolt Specifications Bolting into Cast Aluminum

Table 8.9 Metric Bolt Bolting into Cast Aluminum

Nominal Size (A)	Bolt Torque			
	8.8 (Cast Aluminum)		10.9 (Cast Aluminum)	
	Nm	lbf-ft	Nm	lbf-ft
M3	-	-	-	1
M4	-	-	4	2.6
M5	-	-	8	5.5
M6	9	6	12	9
M8	20	14	28	20
M10	40	28	55	40
M12	70	52	100	73
M14	-	-	-	-
M16	-	-	-	-

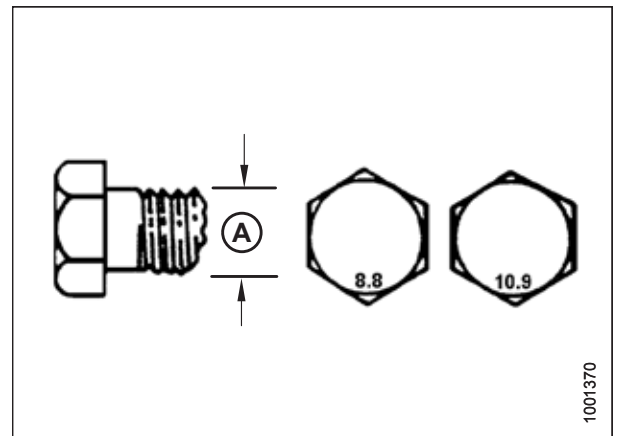

Figure 8.9: Bolt Grades

REFERENCE

Flare-Type Hydraulic Fittings

1. Check flare (A) and flare seat (B) for defects that might cause leakage.
2. Align tube (C) with fitting (D) and thread nut (E) onto fitting without lubrication until contact has been made between flared surfaces.
3. Torque fitting nut (E) to specified number of flats from finger tight (FFFT) or to a given torque value in Table 8.10, page 472.
4. Use two wrenches to prevent fitting (D) from rotating. Place one wrench on fitting body (D), and tighten nut (E) with other wrench to torque shown.
5. Assess final condition of connection.

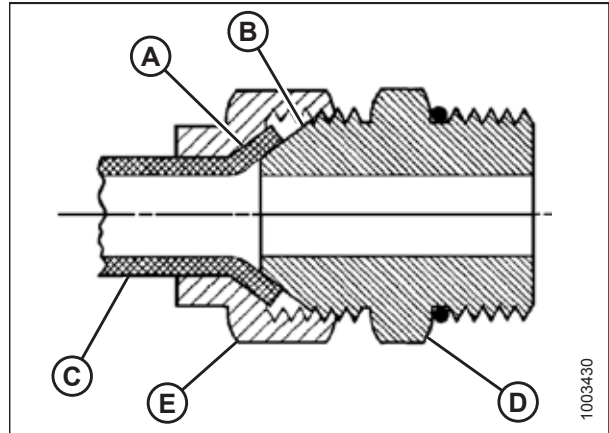

Figure 8.10: Hydraulic Fitting

Table 8.10 Flare-Type Hydraulic Tube Fittings

SAE Dash Size	Thread Size (in.)	Torque Value ⁵⁵		Flats from Finger Tight (FFFT)	
		Nm	lbf-ft	Tube	Swivel Nut or Hose
-2	5/16-24	4-5	3-4	—	—
-3	3/8-24	7-8	5-6	—	—
-4	7/16-20	18-19	13-14	2 1/2	2
-5	1/2-20	19-21	14-15	2	2
-6	9/16-18	30-33	22-24	2	1 1/2
-8	3/4-16	57-63	42-46	2	1 1/2
-10	7/8-14	81-89	60-66	1 1/2	1 1/2
-12	1 1/16-12	113-124	83-91	1 1/2	1 1/4
-14	1 3/16-12	136-149	100-110	1 1/2	1 1/4
-16	1 5/16-12	160-176	118-130	1 1/2	1
-20	1 5/8-12	228-250	168-184	1	1
-24	1 7/8-12	264-291	195-215	1	1
-32	2 1/2-12	359-395	265-291	1	1
-40	3-12	—	—	1	1

55. Torque values shown are based on lubricated connections as in reassembly.

REFERENCE

O-Ring Boss Hydraulic Fittings – Adjustable

1. Inspect O-ring (A) and seat (B) for dirt or obvious defects.
2. Back off lock nut (C) as far as possible. Ensure that washer (D) is loose and is pushed toward lock nut (C) as far as possible.
3. Check that O-ring (A) is **NOT** on threads and adjust if necessary.
4. Apply hydraulic system oil to O-ring (A).

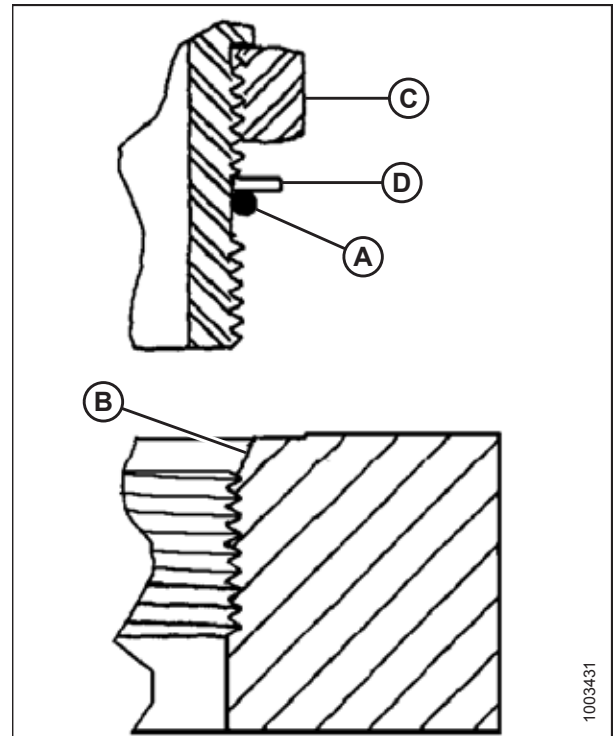

Figure 8.11: Hydraulic Fitting

5. Install fitting (B) into port until backup washer (D) and O-ring (A) contact part face (E).
6. Position angle fittings by unscrewing no more than one turn.
7. Turn lock nut (C) down to washer (D) and tighten to torque shown. Use two wrenches, one on fitting (B) and other on lock nut (C).
8. Check final condition of fitting.

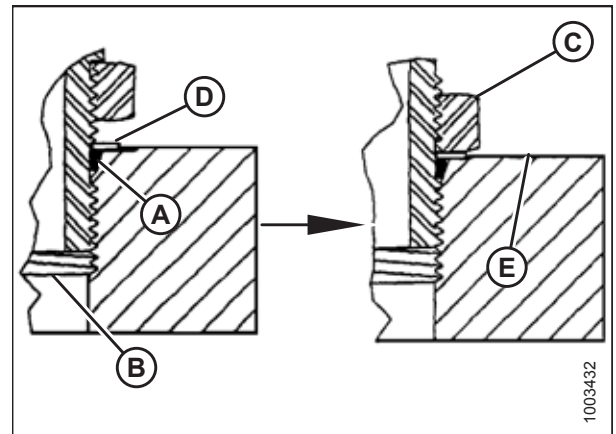

Figure 8.12: Hydraulic Fitting

REFERENCE

Table 8.11 O-Ring Boss (ORB) Hydraulic Fittings – Adjustable

SAE Dash Size	Thread Size (in.)	Torque Value ⁵⁶	
		Nm	lbf·ft (*lbf·in)
-2	5/16-24	6-7	*53-62
-3	3/8-24	12-13	*106-115
-4	7/16-20	19-21	14-15
-5	1/2-20	21-33	15-24
-6	9/16-18	26-29	19-21
-8	3/4-16	46-50	34-37
-10	7/8-14	75-82	55-60
-12	1 1/16-12	120-132	88-97
-14	1 3/8-12	153-168	113-124
-16	1 5/16-12	176-193	130-142
-20	1 5/8-12	221-243	163-179
-24	1 7/8-12	270-298	199-220
-32	2 1/2-12	332-365	245-269

56. Torque values shown are based on lubricated connections as in reassembly.

REFERENCE

O-Ring Boss Hydraulic Fittings – Non-Adjustable

1. Inspect O-ring (A) and seat (B) for dirt or obvious defects.
2. Check that O-ring (A) is **NOT** on threads and adjust if necessary.
3. Apply hydraulic system oil to O-ring.
4. Install fitting (C) into port until fitting is hand-tight.
5. Torque fitting (C) according to values in Table 8.12, page 475.
6. Check final condition of fitting.

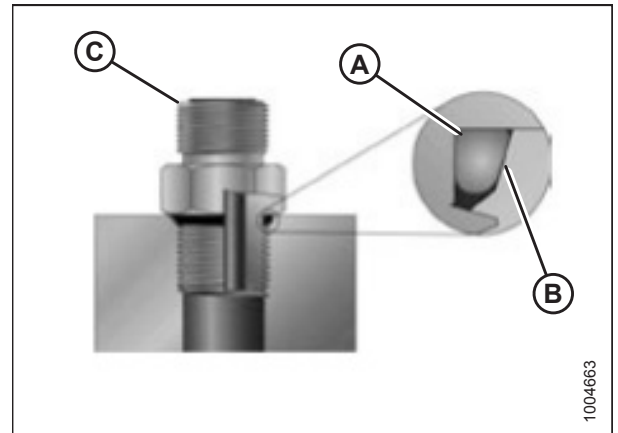

Figure 8.13: Hydraulic Fitting

Table 8.12 O-Ring Boss (ORB) Hydraulic Fittings – Non-Adjustable

SAE Dash Size	Thread Size (in.)	Torque Value ⁵⁷	
		Nm	lbf·ft (*lbf·in)
-2	5/16–24	6–7	*53–62
-3	3/8–24	12–13	*106–115
-4	7/16–20	19–21	14–15
-5	1/2–20	21–33	15–24
-6	9/16–18	26–29	19–21
-8	3/4–16	46–50	34–37
-10	7/8–14	75–82	55–60
-12	1 1/16–12	120–132	88–97
-14	1 3/8–12	153–168	113–124
-16	1 5/16–12	176–193	130–142
-20	1 5/8–12	221–243	163–179
-24	1 7/8–12	270–298	199–220
-32	2 1/2–12	332–365	245–269

57. Torque values shown are based on lubricated connections as in reassembly.

REFERENCE

O-Ring Face Seal Hydraulic Fittings

1. Check components to ensure that sealing surfaces and fitting threads are free of burrs, nicks, scratches, or any foreign material.



Figure 8.14: Hydraulic Fitting

2. Apply hydraulic system oil to O-ring (B).
3. Align tube or hose assembly so that flat face of sleeve (A) or (C) comes in full contact with O-ring (B).
4. Thread tube or hose nut (D) until hand-tight. The nut should turn freely until it is bottomed out.
5. Torque fittings according to values in Table 8.13, page 476.

NOTE:

If applicable, hold hex on fitting body (E) to prevent rotation of fitting body and hose when tightening fitting nut (D).

6. Use three wrenches when assembling unions or joining two hoses together.
7. Check final condition of fitting.

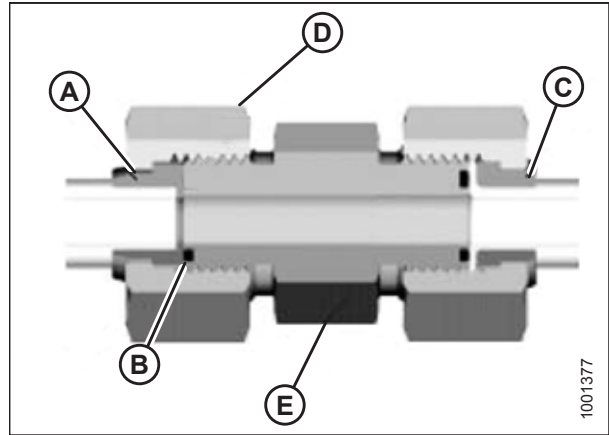

Figure 8.15: Hydraulic Fitting

Table 8.13 O-Ring Face Seal (ORFS) Hydraulic Fittings

SAE Dash Size	Thread Size (in.)	Tube O.D. (in.)	Torque Value ⁵⁸	
			Nm	lbf-ft
-3	Note ⁵⁹	3/16	-	-
-4	9/16	1/4	25-28	18-21
-5	Note ⁵⁹	5/16	-	-
-6	11/16	3/8	40-44	29-32
-8	13/16	1/2	55-61	41-45
-10	1	5/8	80-88	59-65
-12	1 3/16	3/4	115-127	85-94
-14	Note ⁵⁹	7/8	-	-

58. Torque values and angles shown are based on lubricated connection as in reassembly.

59. O-ring face seal type end not defined for this tube size.

REFERENCE

Table 8.13 O-Ring Face Seal (ORFS) Hydraulic Fittings (continued)

SAE Dash Size	Thread Size (in.)	Tube O.D. (in.)	Torque Value ⁶⁰	
			Nm	lbf-ft
-16	1 7/16	1	150–165	111–122
-20	1 11/16	1 1/4	205–226	151–167
-24	1–2	1 1/2	315–347	232–256
-32	2 1/2	2	510–561	376–414

Tapered Pipe Thread Fittings

Assemble pipe fittings as follows:

1. Check components to ensure that fitting and port threads are free of burrs, nicks, scratches, or any form of contamination.
2. Apply pipe thread sealant (paste type) to external pipe threads.
3. Thread fitting into port until hand-tight.
4. Torque connector to appropriate torque angle. The turns from finger tight (TFFT) and flats from finger tight (FFFT) values are shown in Table 8.14, page 477. Make sure that tube end of a shaped connector (typically 45° or 90°) is aligned to receive incoming tube or hose assembly. Always finish alignment of fitting in tightening direction. Never back off (loosen) pipe threaded connectors to achieve alignment.
5. Clean all residue and any excess thread conditioner with appropriate cleaner.
6. Assess final condition of fitting. Pay special attention to possibility of cracks to port opening.
7. Mark final position of fitting. If a fitting leaks, disassemble fitting and check for damage.

NOTE:

Overtorque failure of fittings may not be evident until fittings are disassembled.

Table 8.14 Hydraulic Fitting Pipe Thread

Tapered Pipe Thread Size	Recommended TFFT	Recommended FFFT
1/8–27	2–3	12–18
1/4–18	2–3	12–18
3/8–18	2–3	12–18
1/2–14	2–3	12–18
3/4–14	1.5–2.5	12–18
1–11 1/2	1.5–2.5	9–15
1 1/4–11 1/2	1.5–2.5	9–15
1 1/2–11 1/2	1.5–2.5	9–15
2–11 1/2	1.5–2.5	9–15

60. Torque values and angles shown are based on lubricated connection as in reassembly.

8.2 Recommended Fuel, Fluids, and Lubricants

8.2.1 Storing Lubricants and Fluids

Your machine can only operate at top efficiency if clean fuel and lubricants are used.

- Buy good quality, clean fuel from a reputable Dealer.
- Use clean containers to handle fuel and lubricants.
- Keep containers full to avoid condensation issues.
- Store in an area protected from dust, moisture, and other contaminants.
- Avoid storing fuel over long periods of time. If you have a slow fuel turnover in the windrower or supply tank, add fuel conditioner to avoid condensation problems.
- Store fuel in a convenient place away from buildings.

8.2.2 Fuel Specifications

Use good quality diesel fuel from a reputable supplier. For most year-round service, a No. 2 diesel fuel that meets ASTM specification D975 Grade S15 will provide good performance.

If the vehicle is exposed to extreme cold (below -7°C [20°F]) or is required to operate at colder-than-normal conditions for prolonged periods, use climatized No.2 diesel fuel, or dilute the No.2 fuel with 50% No.1 fuel. This will provide better protection from fuel gelling or wax-plugging of the fuel filters.

Table 8.15 Fuel Specification

Fuel	Specification	Sulphur (by weight)	Water and Sediment (by volume)	Cetane No.	Lubricity
No.2 ULSD	ASTM D975	0.5% maximum	0.05% maximum	40°C (104°F) minimum	520 microns
No.1 and No.2 mix ⁶¹ ULSD	n/a	0.5% maximum preferred (1% maximum)	0.1% maximum	45–55°C (113–131°F) cold weather / high altitude	460 microns

In extreme situations, when available fuels are of poor quality or problems exist which are specific to certain operations, additives can be used; however, the engine manufacturer recommends consulting the fuel supplier or engine manufacturer before using fuel additives. Situations where additives are useful include:

- A cetane improver additive can be used with low cetane fuels.
- A wax crystal modifier can improve fuels with high cold filter plugging points (CFPP).
- An anti-icer can help prevent ice formation in wet fuel during cold weather.
- An antioxidant or storage stability additive can help with fuel system deposits and poor storage stability.
- A lubricity enhancer can be used to increase the lubricity of fuels so that they meet the requirements given in Table 8.15, page 478. Diesel fuel conditioner is available from your Dealer.

61. Optional when operating temperature is below 0°C (32°F).

8.2.3 Lubricants, Fluids, and System Capacities

 **WARNING**

To avoid injury or death, do NOT allow ANY machine fluids to enter the body.

Table 8.16 System Capacities

Lubricant/Fluid	Location	Description	Capacity
Grease	As required unless otherwise specified	SAE multi-purpose high temperature extreme pressure (EP2) performance with 1% max molybdenum disulphide (NLGI Grade 2) lithium base	—
Diesel fuel	Fuel tank	Diesel Grade No. 2, or Diesel Grade No. 1 and 2 mix ⁶² ; refer to 8.2.2 Fuel Specifications, page 478 for more information	378 L (97 US gal)
Hydraulic oil	Hydraulic reservoir	SAE 15W-40 compliant with SAE specs for API class SJ and CH-4 engine oil.	65 L (17.2 US gal)
Gear lubricant	Gearbox	SAE 80W-140 ⁶³ , API service class GL-5. Fully synthetic gear lubricant (SAE J2360 preferred)	2.1 L (2.2 US qt.)
Gear lubricant	Wheel drive ⁶⁴	SAE 75W-90, API service class GL-5. Fully synthetic gear lubricant (SAE J2360 preferred)	1.4 L (1.5 US qt.)
Antifreeze	Engine cooling system	ASTM D-6210 and Fleetguard [®] ES Compleat [™] . Refer to <i>notes</i> following this table	27.5 L (7.3 US gal) ⁶⁵
Engine oil	Engine oil pan	SAE 15W-40 compliant with SAE specs for API class SJ and CH-4 engine oil	11 L (11.6 US qt.)
Air conditioning refrigerant ⁶⁶	Air conditioning system	R134A	2.27 kg (5 lb.)
Air conditioning refrigerant oil ⁶⁷	Air conditioning system total capacity	PAG SP-15	240 cc (8.1 fl. oz.)

62. Optional when operating temperature is below 0°C (32°F).

63. SAE 75W-140 may be substituted for SAE 80W-140 if necessary.

64. SAE 85W-140 API Service Class GL-5. Extreme Pressure Gear Lubricant is used before initial change.

65. Equal parts with high quality, soft, deionized or distilled water as recommended by Supplier.

66. For prior models that have not upgraded to 2.27 kg (5 lb.) of refrigerant order Kit MD #183180, which includes decal to advise of systems 2.27 kg (5 lb.) charge requirement, refer to Service Bulletin 1254.

67. New compressor (MD #183515) comes filled. If installing on 2014 and prior models, refer to Service Bulletin 1254.

REFERENCE

NOTE:

If Fleetguard® ES Compleat™ is unavailable, use a coolant concentrate or prediluted coolant intended for use with heavy-duty diesel engines. Ensure coolant meets a minimum of the following chemical and physical properties:

- Provides cylinder cavitation protection according to fleet study run at or above 60% load capacity.
- Protects the cooling system metals (cast iron, aluminum alloys, and copper alloys such as brass) from corrosion.

An additive package should contain one of the following coolant mixtures:

- Ethylene glycol or propylene glycol base prediluted (40–60%) heavy duty coolant.
- Ethylene glycol or propylene glycol base heavy duty coolant concentrate in a 40–60% mixture of concentrate with quality water.

Water quality is important to the performance of the cooling system. Distilled, deionized, or demineralized water is recommended for mixing with ethylene glycol and propylene glycol base engine coolant concentrate.

IMPORTANT:

Do **NOT** use cooling system sealing additives or antifreeze that contains sealing additives. Ethylene glycol and propylene glycol may alter the freeze temperature. Verify that the mixture meets the freeze protection criteria of its intended use.

8.2.4 Filter Part Numbers

Table 8.17 M155 Filter Part Numbers

Filter	Part Number
Engine oil filter	MD #111974
Charge oil filter	MD #112419
Return oil filter service kit	MD #183620 ⁶⁸
Primary fuel filter element	MD #183800
Secondary fuel filter element	MD #166312
Fuel strainer filter (breather)	MD #111608
Fuel filler filter	MD #163989
Return air filter	MD #109797
Primary element (cab)	MD #111060
Primary air filter element	MD #111954
Safety air filter element	MD #111955

68. Includes filter with seal and O-ring.

8.3 Conversion Chart

Table 8.18 Conversion Chart

Quantity	SI Units (Metric)		Factor	US Customary Units (Standard)	
	Unit Name	Abbreviation		Unit Name	Abbreviation
Area	hectare	ha	$\times 2.4710 =$	acre	acres
Flow	liters per minute	L/min	$\times 0.2642 =$	US gallons per minute	gpm
Force	Newton	N	$\times 0.2248 =$	pound force	lbf
Length	millimeter	mm	$\times 0.0394 =$	inch	in.
Length	meter	m	$\times 3.2808 =$	foot	ft.
Power	kilowatt	kW	$\times 1.341 =$	horsepower	hp
Pressure	kilopascal	kPa	$\times 0.145 =$	pounds per square inch	psi
Pressure	megapascal	MPa	$\times 145.038 =$	pounds per square inch	psi
Pressure	bar (Non-SI)	bar	$\times 14.5038 =$	pounds per square inch	psi
Torque	Newton meter	Nm	$\times 0.7376 =$	pound feet or foot pounds	lbf-ft
Torque	Newton meter	Nm	$\times 8.8507 =$	pound inches or inch pounds	lbf-in
Temperature	degrees Celsius	°C	$(^{\circ}\text{C} \times 1.8) + 32 =$	degrees Fahrenheit	°F
Velocity	meters per minute	m/min	$\times 3.2808 =$	feet per minute	ft/min
Velocity	meters per second	m/s	$\times 3.2808 =$	feet per second	ft/s
Velocity	kilometers per hour	km/h	$\times 0.6214 =$	miles per hour	mph
Volume	liter	L	$\times 0.2642 =$	US gallon	US gal
Volume	milliliter	mL	$\times 0.0338 =$	ounce	oz.
Volume	cubic centimeter	cm ³ or cc	$\times 0.061 =$	cubic inch	in. ³
Weight	kilogram	kg	$\times 2.2046 =$	pound	lb.

REFERENCE

8.4 Engine Error Codes

The following example explains the segments of an error code:

If the cab display module (CDM) displays the Error Code 629S 12F 28C

629S: S represents the J1939 SPN column. Locate code 629 in that column.

12F: F represents the FMI column. Locate code 12 in that column.

28C: C represents the occurrences (count); 28 is the quantity.

J1939 SPN description: Controller #1. The Cummins description of this is engine control module critical internal failure — Bad intelligent device or component.

The Cummins Dealer will request the fault code that corresponds with the number that you have located in the J1939 SPN column.

Cummins Fault Code	J1939 SPN	J1939 FMI	Lamp	J1939 SPN Description	Cummins Description ⁶⁹
719	22	3	Amber	Crankcase pressure	Extended crankcase blow-by pressure circuit — voltage above normal, or shorted to high source
729	22	4	Amber	Crankcase pressure	Extended crankcase blow-by pressure circuit — voltage below normal, or shorted to low source
2114	52	0	Red	Coolant temperature	Coolant temperature 2 — data valid but above normal operational range — most severe level
2111	52	3	Amber	Coolant temperature	Coolant temperature 2 sensor circuit — voltage above normal, or shorted to high source
2112	52	4	Amber	Coolant temperature	Coolant temperature 2 sensor circuit — voltage below normal, or shorted to low source
2113	52	16	Amber	Coolant temperature	Coolant temperature 2 — data valid but above normal operational range — moderately severe level
241	84	2	Amber	Wheel-based vehicle speed	Vehicle speed sensor circuit — data erratic, intermittent, or incorrect
242	84	10	Amber	Wheel-based vehicle speed	Vehicle speed sensor circuit tampering has been detected — abnormal rate of change
148	91	0	Red	Accelerator pedal position	Accelerator pedal or lever position sensor circuit — abnormal frequency, pulse width, or period
147	91	1	Red	Accelerator pedal position	Accelerator pedal or lever position sensor circuit — abnormal frequency, pulse width, or period
1242	91	2	Red	Accelerator pedal position	Accelerator pedal or lever position sensor 1 and 2 — data erratic, intermittent, or incorrect
131	91	3	Red	Accelerator pedal position	Accelerator pedal or lever position sensor circuit — voltage above normal, or shorted to high source

69. The descriptions of Cummins J1939 SPN codes are subject to change at their discretion.

REFERENCE

Cummins Fault Code	J1939 SPN	J1939 FMI	Lamp	J1939 SPN Description	Cummins Description⁷⁰
132	91	4	Red	Accelerator pedal position	Accelerator pedal or lever position sensor circuit — voltage below normal, or shorted to low source
287	91	19	Red	Accelerator pedal position	SAE J1939 multiplexing accelerator pedal or lever sensor system error — received network data in error
528	93	2	Amber	Switch — data	Auxiliary alternate torque validation switch — data erratic, intermittent, or incorrect
2216	94	1	Amber	Fuel delivery pressure	Fuel pump delivery pressure — data valid but above normal operational range — moderately severe level
268	94	2	Amber	Fuel delivery pressure	Fuel pressure sensor circuit — data erratic, intermittent, or incorrect
546	94	3	Amber	Fuel delivery pressure	Fuel delivery pressure sensor circuit — voltage above normal, or shorted to high source
547	94	4	Amber	Fuel delivery pressure	Fuel delivery pressure sensor circuit — voltage below normal, or shorted to low source
2261	94	15	Amber Blinking	Fuel delivery pressure	Fuel pump delivery pressure — data valid but above normal operational range — least severe level
2262	94	17	Amber Blinking	Fuel delivery pressure	Fuel pump delivery pressure — data valid but below normal operational range — least severe level
2215	94	18	Amber	Fuel delivery pressure	Fuel pump delivery pressure — data valid but below normal operational range — moderately severe level
2372	95	16	Amber	Engine fuel filter differential pressure	Fuel filter differential pressure — data valid but above normal operational range — moderately severe level
428	97	3	Amber	Water in fuel indicator	Water in fuel sensor circuit — voltage above normal, or shorted to high source
429	97	4	Amber	Water in fuel indicator	Water in fuel sensor circuit — voltage below normal, or shorted to low source
418	97	15	Amber Blinking	Water in fuel indicator	Water in fuel indicator high — data valid but above normal operational range — least severe level
1852	97	16	Amber	Water in fuel indicator	Water in fuel indicator — data valid but above normal operational range — moderately severe level
415	100	1	Red	Engine oil pressure	Oil pressure low — data valid but below normal operational range — most severe level
435	100	2	Amber	Engine oil pressure	Oil pressure sensor circuit — data erratic, intermittent, or incorrect

70. The descriptions of Cummins J1939 SPN codes are subject to change at their discretion.

REFERENCE

Cummins Fault Code	J1939 SPN	J1939 FMI	Lamp	J1939 SPN Description	Cummins Description⁷¹
135	100	3	Amber	Engine oil pressure	Oil pressure sensor circuit — voltage above normal, or shorted to high source
141	100	4	Amber	Engine oil pressure	Oil pressure sensor circuit — voltage below normal, or shorted to low source
143	100	18	Amber	Engine oil pressure	Oil pressure low — data valid but below normal operational range — moderately severe level
2973	102	2	Amber	Boost pressure	Intake manifold pressure sensor circuit — data erratic, intermittent, or incorrect
122	102	3	Amber	Boost pressure	Intake manifold pressure sensor circuit — voltage above normal, or shorted to high source
123	102	4	Amber	Boost pressure	Intake manifold pressure sensor circuit — voltage below normal, or shorted to low source
124	102	16	Amber	Boost pressure	Intake manifold 1 pressure — data valid but above normal operational range — moderately severe level
2345	103	10	Amber	Turbocharger 1 speed	Turbocharger speed invalid rate of change detected — abnormal rate of change
595	103	16	Amber	Turbocharger 1 speed	Turbocharger #1 speed high — data valid but above normal operational range — moderately severe level
687	103	18	Amber	Turbocharger 1 speed	Turbocharger #1 speed low — data valid but below normal operational range — moderately severe level
155	105	0	Red	Intake manifold #1 temp	Intake manifold air temperature high — data valid but above normal operational range — most severe level
153	105	3	Amber	Intake manifold #1 temp	Intake manifold air temperature sensor circuit — voltage above normal, or shorted to high
154	105	4	Amber	Intake manifold #1 temp	Intake manifold air temperature sensor circuit — voltage below normal, or shorted to low source
488	105	16	Amber	Intake manifold	Intake manifold 1 temperature — data valid but above normal operational range — moderately severe level
295	108	2	Amber	Barometric pressure	Barometric pressure sensor circuit — data erratic, intermittent, or incorrect
221	108	3	Amber	Barometric pressure	Barometric pressure sensor circuit — voltage above normal, or shorted to high source
222	108	4	Amber	Barometric pressure	Barometric pressure sensor circuit — voltage below normal, or shorted to low source

71. The descriptions of Cummins J1939 SPN codes are subject to change at their discretion.

REFERENCE

Cummins Fault Code	J1939 SPN	J1939 FMI	Lamp	J1939 SPN Description	Cummins Description⁷²
231	109	3	Amber	Coolant pressure	Coolant pressure sensor circuit — voltage above normal, or shorted to high source
232	109	4	Amber	Coolant pressure	Coolant pressure sensor circuit — voltage below normal, or shorted to low source
233	109	18	Amber	Coolant pressure	Coolant pressure — data valid but below normal operational range — moderately severe level
151	110	0	Red	Engine coolant temperature	Coolant temperature high — data valid but above normal operational range — most severe level
334	110	2	Amber	Engine coolant temperature	Coolant temperature sensor circuit — data erratic, intermittent, or incorrect
144	110	3	Amber	Engine coolant temperature	Coolant temperature sensor circuit — voltage above normal, or shorted to high source
145	110	4	Amber	Engine coolant temperature	Coolant temperature sensor circuit — voltage below normal, or shorted to low source
2963	110	15	None	Engine coolant temperature	Engine coolant temperature high — data valid but above normal operational range — least severe level
146	110	16	Amber	Engine coolant temperature	Coolant temperature high — data valid but above normal operational range — moderately severe level
235	111	1	Red	Coolant level	Coolant level low — data valid but below normal operational range — most severe level
422	111	2	Amber	Coolant level	Coolant level — data erratic, intermittent, or incorrect
195	111	3	Amber	Coolant level	Coolant level sensor circuit — voltage above normal, or shorted to high source
196	111	4	Amber	Coolant level	Coolant level sensor circuit — voltage below normal, or shorted to low source
2448	111	17	Amber Blinking	Coolant level	Coolant level — data valid but below normal operating range — least severe level
197	111	18	Amber	Coolant level	Coolant level — data valid but below normal operational range — moderately severe level
449	157	0	Red	Injector metering rail 1 pressure	Fuel pressure high — data valid but above normal operational range — moderately severe level
1911	157	0	Amber	Injector metering rail	Injector metering rail 1 pressure — data valid but above normal operational range — most severe level
224 9	157	1	Amber	Injector metering rail 1 pressure	Injector metering rail 1 pressure — data valid but below normal operational range — most severe level

72. The descriptions of Cummins J1939 SPN codes are subject to change at their discretion.

REFERENCE

Cummins Fault Code	J1939 SPN	J1939 FMI	Lamp	J1939 SPN Description	Cummins Description⁷³
554	157	2	Amber	Injector metering rail 1 pressure	Fuel pressure sensor error — data erratic, intermittent, or incorrect
451	157	3	Amber	Injector metering rail 1 pressure	Injector metering rail #1 pressure sensor circuit — voltage above normal, or shorted to high source
452	157	4	Amber	Injector metering rail 1 pressure	Injector metering rail #1 pressure sensor circuit — voltage below normal, or shorted to low source
553	157	16	Amber	Injector metering rail 1 pressure	Injector metering rail #1 pressure high — data valid but above normal operational range — moderately severe level
559	157	18	Amber	Injector metering rail 1 pressure	Injector metering rail #1 pressure low — data valid but below normal operational range — moderately severe level
951	166	2	None	Cylinder power	Cylinder power imbalance between cylinders — data erratic, intermittent, or incorrect
598	167	1	Red	Alternate potential (voltage)	Electrical charging system voltage low — data valid but below normal operational range — most severe level
596	167	16	Amber	Alternate potential (voltage)	Electrical charging system voltage high — data valid but above normal operational range — moderately severe level
597	167	18	Amber	Alternate potential (voltage)	Electrical charging system voltage low — data valid but below normal operational range — moderately severe level
442	168	16	Amber	Electrical potential (voltage)	Battery #1 voltage high — data valid but above normal operational range — moderately severe level
441	168	18	Amber	Electrical potential (voltage)	Battery #1 voltage low — data valid but below normal operational range — moderately severe level
249	171	3	Amber	Ambient air temperature	Ambient air temperature sensor circuit — voltage above normal, or shorted to high source
256	171	4	Amber	Ambient air temperature	Ambient air temperature sensor circuit — voltage below normal, or shorted to low source
263	174	3	Amber	Fuel temperature	Engine fuel temperature sensor 1 circuit — voltage above normal, or shorted to high source
265	174	4	Amber	Fuel temperature	Engine fuel temperature sensor 1 circuit — voltage below normal, or shorted to low source

73. The descriptions of Cummins J1939 SPN codes are subject to change at their discretion.

REFERENCE

Cummins Fault Code	J1939 SPN	J1939 FMI	Lamp	J1939 SPN Description	Cummins Description⁷⁴
261	174	16	Amber	Fuel temperature	Engine fuel temperature — data valid but above normal operational range — moderately severe level
214	175	0	Red	Oil temperature	Engine oil temperature — data valid but above normal operational range — most severe level
425	175	2	Amber	Oil temperature	Engine oil temperature — data erratic, intermittent, or incorrect
212	175	3	Amber	Oil temperature	Engine oil temperature sensor 1 circuit — voltage above normal, or shorted to high source
213	175	4	Amber	Oil temperature	Engine oil temperature sensor 1 circuit — voltage below normal, or shorted to low source
234	190	0	Red	Engine speed	Engine speed high — data valid but above normal operational range — most severe level
689	190	2	Amber	Engine speed	Primary engine speed sensor error — data erratic, intermittent, or incorrect
2321	190	2	None	Engine speed	Engine speed/position sensor #1 — data erratic, intermittent, or incorrect
349	191	16	Amber	Transmission output shaft speed	Transmission output shaft speed — data valid but above normal operational range — moderately severe level
489	191	18	Amber	Transmission output shaft speed	Transmission output shaft speed — data valid but below normal operational range — moderately severe level
319	251	2	Amber Blinking	Real time clock power	Real time clock power interrupt — data erratic, intermittent, or incorrect
2375	412	3	Amber	Exhaust gas recirculation temperature	Exhaust gas recirculation temperature sensor circuit — voltage above normal, or shorted to high source
2376	412	4	Amber	Exhaust gas recirculation temperature	Exhaust gas recirculation temperature sensor circuit — voltage below normal, or shorted to low source
293	441	3	Amber	OEM temperature	Auxiliary temperature sensor input #1 circuit — voltage above normal, or shorted to high source
294	441	4	Amber	OEM temperature	Auxiliary temperature sensor input #1 circuit — voltage below normal, or shorted to low source
292	441	14	Red	Auxiliary temperature 1	Auxiliary temperature sensor input 1 — special instructions
431	558	2	Amber	Accelerator pedal low idle switch	Accelerator pedal or lever idle validation circuit — data erratic, intermittent, or incorrect

74. The descriptions of Cummins J1939 SPN codes are subject to change at their discretion.

REFERENCE

Cummins Fault Code	J1939 SPN	J1939 FMI	Lamp	J1939 SPN Description	Cummins Description⁷⁵
551	558	4	Amber	Accelerator pedal low idle switch	Accelerator pedal or lever idle validation circuit — voltage below normal, or shorted to low source
432	558	13	Red	Accelerator pedal low idle switch	Accelerator pedal or lever idle validation circuit — out of calibration
523	611	2	Amber	System diagnostic code #1	OEM intermediate (PTO) speed switch validation — data erratic, intermittent, or incorrect
2292	611	16	Amber	Fuel inlet meter device	Fuel inlet meter device — data valid but above normal operational range — moderately severe level
2293	611	18	Amber	Fuel inlet meter device	Fuel inlet meter device flow demand lower than expected — data valid but below normal operational range — moderately severe level
115	612	2	Red	System diagnostic code #2	Engine speed/position sensor circuit lost both of two signals from the magnetic pickup sensor — data erratic, intermittent, or incorrect
244	623	4	Amber	Red stop lamp	Red stop lamp driver circuit — voltage below normal, or shorted to low source
1117	627	2		Power supply	Power lost with ignition on — data erratic, intermittent, or incorrect
351	627	12	Amber	Controller #1	Injector power supply — bad intelligent device or component
111	629	12	Red	Controller #1	Engine control module critical internal failure — bad intelligent device or component
343	629	12	Amber	Controller #1	Engine control module warning internal hardware failure — bad intelligent device or component
341	630	2	Amber	Calibration memory	Engine control module data lost — data erratic, intermittent, or incorrect
342	630	13	Red	Calibration memory	Electronic calibration code incompatibility — out of calibration
2217	630	31	Amber	Calibration memory	ECM program memory (ram) corruption — condition exists
2311	633	31	Amber	Fuel control valve #1	Fueling actuator #1 circuit error — condition exists
285	639	9	Amber	SAE J1939 datalink	SAE J1939 multiplexing PGN timeout error — abnormal update rate
286	639	13	Amber	SAE J1939 datalink	SAE J1939 multiplexing configuration error — out of calibration
599	640	14	Red	Engine external protection input	Auxiliary commanded dual output shutdown — special instructions

75. The descriptions of Cummins J1939 SPN codes are subject to change at their discretion.

REFERENCE

Cummins Fault Code	J1939 SPN	J1939 FMI	Lamp	J1939 SPN Description	Cummins Description⁷⁶
237	644	2	Amber	External speed input	External speed input (multiple unit synchronization) — data erratic, intermittent, or incorrect
2377	647	3	Amber	Fan clutch output device driver	Fan control circuit — voltage above normal, or shorted to high source
245	647	4	Amber	Fan clutch output device driver	Fan control circuit — voltage below normal, or shorted to low source
322	651	5	Amber	Injector cylinder #01	Injector solenoid cylinder #1 circuit — current below normal, or open circuit
1139	651	7	Amber	Injector cylinder #01	Injector cylinder #1 — mechanical system not responding properly or out of adjustment
331	652	5	Amber	Injector cylinder #02	Injector solenoid cylinder #2 circuit — current below normal, or open circuit
1141	652	7	Amber	Injector cylinder #02	Injector cylinder #2 — mechanical system not responding properly or out of adjustment
324	653	5	Amber	Injector cylinder #03	Injector solenoid cylinder #3 circuit — current below normal, or open circuit
1142	653	7	Amber	Injector cylinder #03	Injector cylinder #3 — mechanical system not responding properly or out of adjustment
332	654	5	Amber	Injector cylinder #04	Injector solenoid cylinder #4 circuit — current below normal, or open circuit
1143	654	7	Amber	Injector cylinder #04	Injector cylinder #4 — mechanical system not responding properly or out of adjustment
323	655	5	Amber	Injector cylinder #05	Injector solenoid cylinder #5 circuit — current below normal, or open circuit
1144	655	7	Amber	Injector cylinder #05	Injector cylinder #5 — mechanical system not responding properly or out of adjustment
325	656	5	Amber	Injector cylinder #06	Injector solenoid cylinder #6 circuit — current below normal, or open circuit
1145	656	7	Amber	Injector cylinder #06	Injector cylinder #6 — mechanical system not responding properly or out of adjustment
584	677	3	Amber	Starter solenoid lockout relay driver circuit	Starter relay circuit — voltage above normal, or shorted to high source
585	677	4	Amber	Starter solenoid lockout relay driver circuit	Starter relay circuit — voltage below normal, or shorted to low source
2557	697	3	Amber	Auxiliary PWM driver #1	Auxiliary PWM driver #1 — voltage above normal, or shorted to high source
2558	697	4	Amber	Auxiliary PWM driver #1	Auxiliary PWM driver #1 — voltage below normal, or shorted to low source
527	702	3	Amber	Circuit — voltage	Auxiliary input/output 2 circuit — voltage above normal, or shorted to high source

76. The descriptions of Cummins J1939 SPN codes are subject to change at their discretion.

REFERENCE

Cummins Fault Code	J1939 SPN	J1939 FMI	Lamp	J1939 SPN Description	Cummins Description⁷⁷
529	703	3	Amber	Circuit — voltage	Auxiliary input/output 3 circuit — voltage above normal, or shorted to high source
779	703	11	Amber	Auxiliary equipment sensor input	Warning auxiliary equipment sensor input #3 (OEM switch) — root cause not known
2195	703	14	Red	Auxiliary equipment sensor	Auxiliary equipment sensor input 3 engine protection critical — special instructions
778	723	2	Amber	Engine speed sensor #2	Engine speed sensor (camshaft) error — data erratic, intermittent, or incorrect
2322	723	2	None	Engine speed sensor #2	Engine speed/position sensor #2 — data erratic, intermittent, or incorrect
731	723	7	Amber	Engine speed sensor #2	Engine speed/position #2 mechanical misalignment between camshaft and crankshaft sensors — mechanical system not responding properly or out of adjustment
2555	729	3	Amber	Inlet air heater driver #1	Intake air heater #1 circuit — voltage above normal, or shorted to high source
2556	729	4	Amber	Inlet air heater driver #1	Intake air heater #1 circuit — voltage below normal, or shorted to low source
2426	730	3	None	Intake air heater #2	Intake air heater 2 circuit — voltage above normal, or shorted to high source
2425	730	4	None	Intake air heater #2	Intake air heater 2 circuit — voltage below normal, or shorted to low source
133	974	3	Red	Remote accelerator	Remote accelerator pedal or lever position sensor circuit — voltage above normal, or shorted to high source
134	974	4	Red	Remote accelerator	Remote accelerator pedal or lever position sensor circuit — voltage below normal, or shorted to low source
288	974	19	Red	Remote accelerator	SAE J1939 multiplexing remote accelerator pedal or lever data error — received network data in error
284	1043	4	Amber	Internal sensor voltage supply	Engine speed/position sensor (crankshaft) supply voltage circuit — voltage below normal, or shorted to low source
2182	1072	3	Amber	Engine brake output #1	Engine brake actuator driver 1 circuit — voltage above normal, or shorted to high source
2183	1072	4	Amber	Engine brake output #1	Engine brake actuator driver 1 circuit — voltage below normal, or shorted to low source
2367	1073	3	Amber	Engine compression brake output #2	Engine brake actuator circuit #2 — voltage above normal, or shorted to high source
2363	1073	4	Amber	Engine compression brake output #2	Engine brake actuator circuit #2 — voltage below normal, or shorted to low source

77. The descriptions of Cummins J1939 SPN codes are subject to change at their discretion.

REFERENCE

Cummins Fault Code	J1939 SPN	J1939 FMI	Lamp	J1939 SPN Description	Cummins Description⁷⁸
2265	1075	3	Amber	Electric lift pump for engine fuel	Fuel priming pump control signal circuit — voltage above normal, or shorted to high source
2266	1075	4	Amber	Electric lift pump for engine fuel	Fuel priming pump control signal circuit — voltage below normal, or shorted to low source
2368	1112	3	Amber	Engine brake output #3	Engine brake actuator driver 3 circuit — voltage above normal, or shorted to high source
2365	1112	4	Amber	Engine brake output #3	Engine brake actuator driver output 3 circuit — voltage below normal, or shorted to low source
697	1136	3	Amber	Sensor circuit — voltage	ECM internal temperature sensor circuit — voltage above normal, or shorted to high source
698	1136	4	Amber	Sensor circuit — voltage	ECM internal temperature sensor circuit — voltage below normal, or shorted to low source
691	1172	3	Amber	Turbocharger #1 compressor inlet temperature	Turbocharger #1 compressor inlet temperature sensor circuit — voltage above normal, or shorted to high source
692	1172	4	Amber	Turbocharger #1 compressor inlet temperature	Turbocharger #1 compressor inlet temperature sensor circuit — voltage below normal, or shorted to low source
2373	1209	3	Amber	Exhaust gas pressure	Exhaust gas pressure sensor circuit — voltage above normal, or shorted to high source
2374	1209	4	Amber	Exhaust gas pressure	Exhaust gas pressure sensor circuit — voltage below normal, or shorted to low source
338	1267	3	Amber	Vehicle accessories relay driver	Idle shutdown vehicle accessories relay driver circuit — voltage above normal, or shorted to high source
339	1267	4	Amber	Vehicle accessories relay driver	Idle shutdown vehicle accessories relay driver circuit — voltage below normal, or shorted to low source
272	1347	3	Amber	Fuel pump pressurizing assembly #1	High fuel pressure solenoid valve circuit — voltage above normal, or shorted to high source
271	1347	4	Amber	Fuel pump pressurizing assembly #1	High fuel pressure solenoid valve circuit — voltage below normal, or shorted to low source
281	1347	7	Amber	Fuel pump pressurizing assembly #1	High fuel pressure solenoid valve #1 — mechanical system not responding properly or out of adjustment
497	1377	2	Amber	Switch circuit	Multiple unit synchronization switch circuit — data erratic, intermittent, or incorrect

78. The descriptions of Cummins J1939 SPN codes are subject to change at their discretion.

REFERENCE

Cummins Fault Code	J1939 SPN	J1939 FMI	Lamp	J1939 SPN Description	Cummins Description⁷⁹
649	1378	31	Amber Blinking	Engine oil change interval	Change lubricating oil and filter — condition exists
297	1388	3	Amber	Auxiliary pressure	Auxiliary pressure sensor input #2 circuit — voltage above normal, or shorted to high source
298	1388	4	Amber	Auxiliary pressure	Auxiliary pressure sensor input #2 circuit — voltage below normal, or shorted to low source
296	1388	14	Red	Auxiliary pressure	Auxiliary pressure sensor input 1 — special instructions
211	1484	31	None	J1939 error	Additional auxiliary diagnostic codes logged — condition exists
1256	1563	2	Amber	Control module identification input state	Control module identification input state error — data erratic, intermittent, or incorrect
1257	1563	2	Red	Control module identification input state	Control module identification input state error — data erratic, intermittent, or incorrect
199	1661	4	Amber	Engine automatic start lamp	Engine automatic start lamp driver circuit — voltage above normal, or shorted to high source
2263	1800	16	Amber	Battery temperature	Battery temperature — data valid but above normal operational range — moderately severe level
2264	1800	18	Amber	Battery temperature	Battery temperature — data valid but below normal operational range — moderately severe level
1239	2623	3	Amber	Accelerator pedal position	Accelerator pedal or lever position sensor 2 circuit — voltage above normal, or shorted to high source
1241	2623	4	Amber	Accelerator pedal position	Accelerator pedal or lever position sensor 2 circuit — voltage below normal, or shorted to low source
2346	2789	15	None	System diagnostic code #1	Turbocharger turbine inlet temperature (calculated) — data valid but above normal operational range — least severe level
2347	2790	15	None	System diagnostic code #1	Turbocharger compressor outlet temperature (calculated) — data valid but above normal operational range — least severe level
757	2802	31	Amber	Electronic control module	Electronic control module data lost — condition exists
2115	2981	3	Amber	Coolant pressure	Coolant pressure 2 circuit — voltage above normal, or shorted to high source
2116	2981	4	Amber	Coolant pressure	Coolant pressure 2 circuit — voltage below normal, or shorted to low source

79. The descriptions of Cummins J1939 SPN codes are subject to change at their discretion.

REFERENCE

Cummins Fault Code	J1939 SPN	J1939 FMI	Lamp	J1939 SPN Description	Cummins Description⁸⁰
2117	2981	18	Amber	Coolant pressure	Coolant pressure 2 — data valid but below normal operational range — moderately severe level
386	3509	3	Amber	5 volts dc supply	Sensor supply voltage #1 circuit — voltage above normal, or shorted to high source
352	3509	4	Amber	5 volts dc supply	Sensor supply voltage #1 circuit — voltage below normal, or shorted to low source
227	3510	3	Amber	5 volts dc supply	Sensor supply voltage #2 circuit — voltage above normal, or shorted to high source
187	3510	4	Amber	5 volts dc supply	Sensor supply voltage #2 circuit — voltage below normal, or shorted to low source
239	3511	3	Amber	System diagnostic code #2	Sensor supply voltage #3 circuit — voltage above normal, or shorted to high source
238	3511	4	Amber	System diagnostic code #1	Sensor supply voltage #3 circuit — voltage below normal, or shorted to low source
2185	3512	3	Amber	System diagnostic code #1	Sensor supply voltage #4 circuit — voltage above normal, or shorted to high source
2186	3512	4	Amber	System diagnostic code #1	Sensor supply voltage #4 circuit — voltage below normal, or shorted to low source
193	520199	3	Amber	Cruise control	Cruise control (resistive) signal circuit — voltage above normal, or shorted to high source
194	520199	4	Amber	Cruise control	Cruise control (resistive) signal circuit — voltage below normal, or shorted to low source

80. The descriptions of Cummins J1939 SPN codes are subject to change at their discretion.

REFERENCE

8.5 Cab Display Module Error Codes

The CDM displays error codes when there is a fault with one of the sensors that monitor and control windrower operation. Use the list of error codes to help identify a specific problem with the windrower.

NOTE:

In the case of dual codes being shown for an item (primarily the solenoid valves), the first code indicates a SHORT CIRCUIT condition, while the second code indicates an OPEN CIRCUIT condition. That is, E41 would be a SHORT in the reel aft solenoids (P55, P59), while E141 would indicate an OPEN circuit.

Codes	CDM Display	Description
E1		
E2	RTCH NOT ALLOWED	Return to cut activated with the header off
E3	CDM CAN BUS ERROR	E3 is triggered when the CDM module can not transmit and/or receive CANBUS. Check CAN signals on pin 22, 23, 24 and the power ground on 9, 11 and 25 in connector P38. If all signals check out OK, check CANBUS cabling and end bus terminations in place. The terminators are located behind the Cab Display Module (CDM) connector P41, and near the engine Electronic Control Module (ECM) connector P40. The resistance should be 120 ohm resistance
E4	HDR DRV NOT ALLOWED	HEADER ENGAGE switch activated while in engine-forward
E5	CHECK HEADER ID	Header ID change has been detected while the header was engaged
E6	TEMP GAUGE SHORT	Wiring/connection problem
E7	SPEED STICK SHORT	Wiring/connection problem
E8	HEADER ENABLE SHORT	Wiring/connection problem
E9	WCM ENABLE SHORT	Wiring/connection problem
E10	CDM INTERNAL ERROR	A generic internal CDM error summarizing a number of internal problems
E11	CDM POWER UP	Indicates that the voltage on CDM connector P38, pin 26 is too low or the ground connections are loose; could be a wiring issue
E12	WCM POWER UP	E12 indicates that the voltage on WCM connector P34, pin 2 is too low or the ground on pin 9 is loose; could be a wiring issue
E13	FUEL SOLENOID	WCM fuel solenoid output fault detected
E14		
E15	KNIFE DRIVE PWM P68	Knife drive – PWM solenoid P68 drive fault detected
E16	DRAPER DRIVE PWM P69	Draper drive – PWM solenoid P69 drive fault detected
E17	REEL DRIVE PWM P70	Reel drive – PWM solenoid P70 drive fault detected
E18		
E19	E119 Load Sense P75	Disc block valve – Solenoid P75 drive fault detected
E20		
E21	E121 REVERSER P106	Reverser solenoid P106 fault detected
E22		
E23	E123 REVERSER	Reverser – solenoid (P65, P66, P67) fault detected

REFERENCE

Codes		CDM Display	Description
E24	E124	DECK SHFT RIGHT P95	Right deck shift solenoid P95 fault detected
E25	E125	DECK SHFT LEFT P96	Left deck shift solenoid P96 fault detected
E26	E126	DWA UP	DWA raise solenoid P72, P73 fault detected
E27	E127	DWA DOWN	DWA lower solenoid P72, P73, fault detected circuit
E28	E128	TILT RETRACT	Header tilt retract solenoid P54, fault detected
E29	E129	TILT EXTEND	Header tilt extend solenoid P53, P54, fault detected
E30	E130	4 WAY VALVE P62	4-way valve solenoid P62 fault detected
E31	E131	BYPASS VALVE P52	Bypass valve solenoid P52 fault detected
E32	E132	HEADER UP/DOWN P57	Header up/down solenoid P57, fault detected
E33	E133	SCREEN CLEANERS	Screen cleaner output fault detected
E34	E134	RIGHT STOP LAMP	Right stop lamp output fault detected
E35	E135	LEFT STOP LAMP	Left stop lamp output fault detected ⁸¹
E36	E136	RIGHT TURN LAMP	Right turn lamp output fault detected ⁸²
E37	E137	LEFT TURN LAMP	Left turn lamp output fault detected
E38	E138	MAIN DRIVE	Main header drive solenoid P71 fault detected
E39	E139	LOW RANGE P61	Low range solenoid P61 fault detected
E40	E140	HIGH RANGE P60	High range solenoid P60 fault detected
E41	E141	REEL AFT	Reel aft solenoid P55, P59, fault detected
E42	E142	REEL FORE	Reel fore solenoid P55, P59, fault detected
E43	E143	REEL UP/DOWN P58	Reel up/down solenoid P58, P52, P62 fault detected
E44	E144	FLOAT RHS P64	Right float solenoid P64, fault detected
E45	E145	FLOAT LHS P63	Left float solenoid P63, fault detected
E46		SENSOR VOLTS HIGH	WCM's 9V Sensor voltage output high (wire 5)
E47		SENSOR VOLTS LOW	WCM's 9V Sensor voltage output low (wire 5)
E48		WCM OVER TEMP	E49 the temp limits are set to -10C and +85C representing the board temp read by the chip inside the WCM module; this is to protect the module when operating at extreme temp; the WCM outputs will stop working (they stay off) when the board temp is below -20C or above 120C; the high temp may indicate a strong/ massive short circuit in the cabling on the WCM outputs
E49		WCM LOW TEMP	WCM low temp fault
E50		BATT+ OUT OF RANGE	System voltage above 15.5 VDC
E51	E151	DISK DRIVE PWM P68	Disk header drive solenoid P68 fault detected
E52			
E53			

81. If road light kit is not installed, CDM will display E135 LEFT STOP LAMP as a malfunction in CAB-FORWARD mode.
 82. If road light kit is not installed, CDM will display E134 RIGHT STOP LAMP as a malfunction in CAB-FORWARD mode.

REFERENCE

Codes		CDM Display	Description
E54			
E55		DISK SPD OVERLOAD	Low disk speed detected < setpoint
Error codes E56 to E63 not allocated			
E64		HEADER OIL PRESSURE	Header drive charge pressure low (Switch MD #112848 on return manifold)
E65		KNIFE OVERLOAD	Low knife speed detected < setpoint
E66		### LOW VOLTS	Low system voltage <11.5 VDC
E67		TRANS OIL PRESSURE	Supercharge pressure low (switch MD #139775)
E68		HYDRAULIC OIL HOT	Oil tank temp >110°C (230°F)
E69		ENGINE AIR FILTER	Engine air filter plugged
E70		HYDRAULIC FILTER	Hydraulic filter pressure too high (MD #139722)
E71		LOW HYDRAULIC OIL	Low hydraulic oil level sensor tripped (MD #138473)
E72		### HIGH VOLTS	System voltage above 15.5 VDC
Error codes E73 to E100 not allocated			
E101		SPI ERROR	Indicates that the communication between the two micros inside the WCM module is not working properly; could be resolved by reprogramming the WCM
E102		CAN ERROR	E102 is detected by the WCM module so the issue is related to the CANBUS signals on the WCM end; it may happen when the CDM sees the engine ECU but not the WCM (not hooked up or experiencing power or CANBUS problems; may also happen if the CDM connector P38, pin 8 signal is malfunctioning or the wire between the CDM connector P38, pin 8 and WCM connector P36, pin 30 is not making a proper connection). The wire at the CDM is CB60 and at the WCM CH60
E103		EEPROM READ ERROR	Internal errors specific to the WCM; try reprogramming the module
E104		EEPROM WRITE ERROR	Internal errors specific to the WCM; try reprogramming the module
E105		TEMP SENSOR ERROR	Internal errors specific to the WCM; try reprogramming the module

Index

A

A Series headers	
A30D	
auger speed	303
reel speed	304
A30S	
auger speed	303
A40D	
auger speed	303
reel only speed	305
reel speed	304
reel speed while moving	306
reel to ground speed	307
attaching header with hydraulic center-link and optional self-alignment kit	243
attaching header with mechanical center-link	254
attaching to M155	243
auger speed	303
knife speed	309
air conditioning, <i>See</i> HVAC systems	
air intake systems	345
antenna mountings	62
API	
definition	25
assembly	
attaching A Series header to M155	243
attaching R Series header to M155	
hydraulic center-link without self-alignment kit	272
attaching R Series header to M155 SP Windrower	
hydraulic center-link with optional self-alignment kit	267
attaching R1 SP Series header to M155	
hydraulic center-link without self-alignment kit	272
attaching R1 SP to M155 SP Windrower	
hydraulic center-link with optional self-alignment kit	267
ASTM	
definition	25
auger speeds	303
A30D header	303
A30S header	303
A40D header	303
auto raise height feature	214
programming auto raise height	214
using auto raise height feature	215
automated steering systems	461
autosteer, <i>See</i> automated steering systems	

B

batteries	
adding electrolyte to batteries	386
battery safety	8
boosting	385
charging	383
connecting	389
installing	388
main disconnect switch	382
maintaining	382
removing	387
belts	377
A/C compressor belt	
replacing	379
tensioning	379
engine belts	
alternator/fan belt	
replacing	377
tensioning	377
bolts	
definition	25
brakes	
park brake	330

C

cab display module (CDM)	
CDM/WCM fault codes	154
configuring the CDM	88
guidelines	87
configuring the windrower, <i>See</i> CanWin service tool	
display and sound options	89
backlighting	93
buzzer volume	92
display contrast	94
display language	90
display units	91
engine and windrower functions	73
engine error codes	154, 482
engine warning lights	84
header functions	74
header sensors	124
header float sensor	128
header height sensor	124
header tilt sensor	126
locking CDM buttons	
auger speed	118
displaying locked buttons	122
draper speed	117
header float	114

INDEX

header tilt	112
knife speed	119
reel fore-aft	115
reel speed	121
rotary disc speed	120
operating screens.....	75
programming	
auger reel speed.....	108
auto raise height.....	101
engine intermediate speed control (ISC)	110
hay conditioner	107
header cut width	104
header index mode	99
hydraulic center-link.....	102
hydraulic overload pressure.....	98
knife overload speed	96
knife speed	95
return to cut mode	100
rotary disc hydraulics.....	103
rotary disc overload speed	97
swath compressor.....	105
tire size	109
swath compressor sensor calibration	130
troubleshooting	
activating hydraulic purge	152
draper drive activate function	145
engine error codes	131
forcing a header ID	136
header sensors	133
header tilt activate function.....	141
header up/down.....	138
knife drive circuit	143
reel drive circuit activate function.....	147
reel fore-aft activate function	151
reel up/down activate function	140
rotary disc drive circuit activate function.....	149
sensor input signals.....	135
windrower error codes	131
warning/alarms	84
cab suspension limit straps.....	331
cab temperature, <i>See</i> HVAC systems	
cab-forward	
definition.....	25
CDM, <i>See</i> cab display module (CDM)	
center-links	25
<i>See also</i> , mechanical links	
definition.....	25
self-locking center-link hook mechanism	209
CGVW	
definition.....	25
charge air cooling	370
circuit breakers	409
accessing	409
replacing	410
climate controls	56–57

<i>See also</i> HVAC systems	
component locations	35
compressors, <i>See</i> HVAC systems	
configuring the CDM, <i>See</i> cab display module (CDM)	
configuring the windrower, <i>See</i> CanWin service tool	
consoles	39
conversion chart	481
cutting height	211

D

D Series headers	
attaching	219
attaching header boots	218
deck shift.....	300
deck shift control.....	300
setting float options	301
draper index	
setting draper index	296
draper speed	
setting draper speed	294
setting draper to ground speed	294
setting independent of ground speed.....	298
setting minimum draper speed.....	295
header float	
float options with deck shift	301
header position	290
reel fore-aft position	290
hydraulics configuration - D Series	289
knife speed	299
reel height	290
reel speed.....	291
reel index	291
reel minimum speed	291
reel only speed.....	293
reel to ground speed	291
D1 Series headers	
attaching	219
attaching header boots	218
deck shift.....	300
deck shift control.....	300
setting float options	301
draper index	
setting draper index	296
draper speed	
setting draper speed	294
setting draper to ground speed	294
setting independent of ground speed.....	298
setting minimum draper speed.....	295
header float	
float options with deck shift	301
header position	290
reel fore-aft position	290
knife speed	299
reel height	290

INDEX

reel speed	
reel index	291
reel minimum speed	291
reel only speed.....	293
reel to ground speed	291
DDD	
definition.....	25
decals	
fuse box decal	411
GSL header switch functions	69
location of safety signs.....	13
deck shift control.....	300
declaration of conformity	i
definition of terms.....	25
DK	
definition.....	25
DKD	
definition.....	25
draper index	
setting for D Series	296
setting for D1 Series headers.....	296
draper speed	
setting for D Series	294
setting for D1 Series headers.....	294
setting independent of ground speed	298
setting minimum draper speed.....	295
drive wheels	
installing	432
nut tightening procedure.....	427
servicing	430
driving the windrower	169
cab-forward operation	172
driving on the road.....	180
engine-forward operation.....	174
entering/exiting	170
reverse in cab-forward mode	173
reverse in engine-forward mode.....	175
spin turn.....	176
stopping	177
E	
ECM	
definition.....	25
electrical systems	168, 381
accessing circuit breakers and fuses	409
batteries.....	382
adding electrolyte	386
battery main disconnect switch	382
boosting the batteries	385
charging the batteries.....	383
connecting.....	389
installing	388
maintaining the battery	382
removing.....	387
checking and replacing fuses.....	410
circuit breakers and fuses	409
fuse box decal	411
inspecting 125A main fuse.....	412
preventing damage to electrical system	381
replacing 125A main fuse	412
replacing circuit breaker/relay.....	410
engine compartment hoods, <i>See</i> hoods	
engine cooling systems	
changing coolant.....	366
cooler box.....	369
cleaning cooler.....	371
cleaning cooler box components	372
screen cleaner duct to screen clearance.....	374
cooler box screen	
adjusting clearance	374
cleaning screen	371
closing	374
opening	370
engine coolant	
adding coolant	368
checking level	365
checking strength	365
cleaning tank	366
draining coolant	366
radiator	
inspecting radiator cap	364
engine operation	
adjusting the throttle.....	380
engine speed.....	380
engine temperature.....	167
fuelling.....	166
intermediate speed control (ISC).....	164
oil pressure	168
shutting down the engine.....	165
starting the engine	162
engine warm-up	164
engine-forward	
definition.....	25
engines.....	339
air filters	
cleaning air filter primary element.....	350
installing primary air filter	348
installing secondary air filter	351
removing primary air filter.....	346
removing secondary air filter	351
air intake system.....	345
belts	377
charge air cooling.....	370
checking interlock	326
controls and gauges.....	65
electronics	11
engine cooling system.....	364
engine error codes on CDM display	154
gearbox maintenance	375

INDEX

adding lubricant	375
changing lubricant	376
checking lubricant level.....	375
general inspection.....	339
inspecting exhaust system	377
manuals	339
power	11
safety.....	10
speed.....	11
turning engine manually.....	339
warning lights.....	84, 168
error codes	
cab display module (CDM)	494
engine error codes	482
displaying.....	131
windrower error codes	
displaying.....	131
evaporator heater cores	336
cleaning.....	337

F

FFFT	
definition.....	25
filters	
engine air filters	
cleaning air filter primary element	350
installing primary air filter	348
installing secondary air filter	351
removing primary air filter.....	346
removing secondary air filter	351
servicing air filter restriction indicator	345
fuel filters	354
installing primary fuel filter.....	357
installing secondary fuel filter	359
removing primary fuel filter.....	355
removing secondary fuel filter.....	359
HVAC filters	
fresh air filter	
inspecting/cleaning filter element	333
installing	333
removing	332
return air cleaner/filter	
cleaning	335
servicing	334
hydraulic filters	
changing oil filters.....	417
charge oil filter	417
installing	418
removing	418
return oil filter	418
installing	420
removing	419
final drives	194
finger tight	

definition.....	25
float booster springs	
spring with internal booster spring kit.....	465
float springs	
spring with external booster spring kit	465
floats, <i>See</i> header float	
fluids, fuel, and lubricants.....	478
capacities	479
fuel specifications	478
storing	478
fuel systems	353
fluids, fuel, and lubricants.....	478
fuel filters	354
fuel/water separator	362
installing primary fuel filter.....	357
installing secondary fuel filter	359
removing primary fuel filter.....	355
removing secondary fuel filter.....	359
fuel specifications	478
fuel tank	
draining	360
filling	166
fuel tank vent filter	
installing	353
removing	353
fuel/water separator	362
removing water from fuel system	362
priming	
procedure	363
system priming.....	363
fuel, fluids, and lubricants	
engine oil.....	341
hydraulic oil	414
fuse box decals	411
fuses	409
accessing	409
checking and replacing.....	410
inspecting and replacing 125A	412

G

gearbox	375
glossary	25
GPS automated steering systems.....	461
GSL	69
<i>See also</i> header controls	
definition.....	25
GVW	
definition.....	25

H

header angles	208
header controls.....	68

INDEX

console header switches.....	72	self-aligning hydraulic center-link	219
deck shift/float preset switch.....	72	attaching header boots.....	218
display selector switch	70	detaching	236
ground speed lever (GSL) header switches.....	69	hydraulic center-link	236
header drive reverse button.....	68	mechanical center-link	240
header drive switch	68	D1 Series headers	
header position switches	70	attaching	
reel and disc speed switches	71	non-self-aligning hydraulic center-link.....	225
header drives.....	206	self-aligning hydraulic center-link	219
header float	198	attaching header boots.....	218
adjusting float using drawbolts.....	200	detaching	236
checking float.....	199	hydraulic center-link	236
float operating guidelines	198	definition.....	25
float options and presets.....	201	drop rate	423
float options with deck shift (D Series and D1 Series)	301	R Series headers	
header levelling.....	203	attaching.....	267
header operation	196	hydraulic center-link without self-alignment kit	272
engaging the header.....	206	mechanical center-link	277
header and reel hydraulics.....	421	self-aligning hydraulic center-link	267
header angle	208	detaching	282
header drive.....	206	hydraulic center-link	282
header drop rate.....	215	mechanical center-link	285
levelling the header.....	203	R1 Series headers	
operating with a header		attaching.....	267
A Series header	303	mechanical center-link	277
D Series header	289	detaching	282
D1 Series header	289	hydraulic center-link	282
header float.....	198	mechanical center-link	285
R Series header	310	R1 SP	
R1 Series header.....	310	attaching	
reversing the header.....	207	self-aligning hydraulic center-link	267
header sensors		R1 SP Series headers	
calibrating header sensors	124	attaching	
header float sensor	128	hydraulic center-link without self-alignment kit	272
header height sensor.....	124	heater shut-off valves.....	56
header tilt sensor.....	126	heating, <i>See</i> HVAC systems	
switching installed sensors on or off.....	133	hex keys	
header tilt		definition.....	25
calibrating header tilt sensor.....	126	hoods	
header tilt control lockout on CDM	112	closing from highest position.....	317
testing header tilt activate function.....	141	closing from lower position.....	315
headers		opening to highest position.....	316
A Series headers		opening to lowest position.....	314
attaching		horns	64
mechanical center-link	254	HVAC systems	
non-self-aligning hydraulic center-link	249	A/C compressor	
self-aligning hydraulic center-link	243	compressor belt	
detaching	260	replacing.....	379
hydraulic center-link	260	tensioning	379
mechanical center-link	263	coolant cycling	161
D Series headers		servicing the compressor	338
attaching		A/C condenser.....	336
mechanical center-link	231	air distribution.....	56
non-self-aligning hydraulic center-link	225		

INDEX

- compressor 338
 - controls 57
 - cover
 - installing cover 337
 - removing cover 336
 - evaporator heater core 336
 - cleaning 337
 - filters
 - fresh air filter
 - installing 333
 - removing 332
 - fresh air intake filter
 - cleaning filter element..... 333
 - return air cleaner/filter
 - cleaning 335
 - servicing 334
 - fresh air intake filter 332
 - heater shut-off valve..... 56
 - hydraulic oil..... 414
 - changing hydraulic oil 416
 - checking and filling 415
 - hydraulic system
 - filters
 - filter part numbers 480
 - hydraulic filters
 - charge oil filter
 - installing 418
 - removing 418
 - return oil filter
 - installing 420
 - removing 419
 - knife drive
 - testing knife drive circuit using CDM 143
 - hydraulics
 - changing hydraulic oil filters..... 417
 - D Series header hydraulics..... 289
 - fittings
 - flare-type 472
 - O-ring boss (ORB) adjustable 473
 - O-ring boss (ORB) non-adjustable 475
 - O-ring face seal (ORFS) 476
 - tapered pipe thread fittings 477
 - header and reel hydraulics..... 421
 - flow control blocks..... 422
 - header drop rate 423
 - pressure compensator valve 422
 - reel drop rate..... 423
 - hydraulic filters
 - charge oil filter 417
 - return oil filter 418
 - hydraulic hoses and lines..... 421
 - hydraulic oil cooler 416
 - hydraulic safety 6
 - traction drive hydraulics 424
 - charge pump pressure 425
 - transmission oil pressure..... 425
 - warnings..... 414
- ## K
- knife drives
 - testing knife drive circuit using CDM..... 143
 - knife speeds
 - A Series header..... 309
 - D Series header 299
 - D1 Series header..... 299
- ## L
- lighting 49–50
 - beacons..... 406
 - engine-forward lighting 52
 - field lights
 - adjusting field lights 395
 - replacing bulb 396
 - floodlights
 - adjusting cab-forward floodlights..... 397
 - adjusting rear floodlights..... 403
 - replacing bulb in cab-forward flood light..... 397
 - replacing bulb in rear flood light..... 403
 - headlights
 - aligning headlights 393
 - replacing bulb 390
 - HID auxiliary lighting..... 53, 399, 461
 - adjusting HID lights 399
 - replacing lamp 400
 - interior lights..... 58
 - ambient light 408
 - console gauge light 407
 - dome light 408
 - red and amber lights
 - replacing bulbs..... 405
 - red taillights
 - replacing bulb 406
 - turn signal indicators 409
 - lubricating the windrower..... 323
 - lubricants, fluids, and system capacities 479
 - lubricating engine gearbox..... 375
 - lubricating wheel drive..... 427
 - adding lubricant 428
 - changing wheel drive lubricant..... 429
 - checking lubricant levels 427
 - lubrication points 324
 - lubrication procedure 323
 - recommended fuel, fluids, and lubricants 478
 - storing lubricants and fluids 478

INDEX

M

maintenance and servicing.....	313
A/C compressor belt	
replacing	379
tensioning	379
battery	382
daily checks and maintenance	162
electrical system	381
engine.....	339
charge air cooling	370
engine belt	377
general engine inspection	339
turning the engine manually	339
engine compartment	
opening and closing platforms	318
engine cooling system.....	364
engine exhaust system	377
engine gearbox.....	375
engine oil.....	341
checking level	341
filter part numbers	480
fuel system	353
fuel, fluids, and lubricants.....	478
HVAC system.....	332
fresh air filter	
cleaning filter element.....	333
installing	333
hydraulic oil tank	
checking and filling hydraulic oil.....	415
lighting	
aligning headlights	393
lubricating the windrower	323
maintenance schedule	442
operator presence system	325
operator's station	325
checking engine interlock	326
preparing for servicing	313
priming	
procedure	363
system priming.....	363
safety.....	5
safety systems	325
wheels and tires.....	426
caster wheels.....	433
maintenance platforms.....	318
maintenance schedule.....	442
metric bolts	
torque specifications	469
minimum reel speed	291

N

NPT	
definition.....	25

O

oils (engine).....	341
adding.....	344
capacities and specifications	479
changing engine oil.....	343
checking level.....	341
draining.....	343
replacing engine oil filter	344
operations.....	159
<i>See also</i> engine operation	
<i>See also</i> header operation	
auto raise height feature	214
programming auto raise height feature	214
using auto raise height.....	215
break-in period.....	160
daily checks.....	162
driving the windrower.....	169
header float	198
operating with a header	196
A Series header	303
D Series header	289
D1 Series header	289
R Series header	310
R1 Series header.....	310
owner/operator responsibilities.....	155
preseason checks/annual service	161
distributing A/C compressor coolant	161
return to cut feature	
programming return to cut feature	212
using return to cut feature	213
safety props	196
symbols.....	156
operator presence system.....	41
engine and transmission.....	41
header drive.....	41
operator's seat	
adjusting armrest.....	43
adjusting armrest angle.....	45
adjusting fore-aft position	42
adjusting lumbar support.....	45
adjusting seat tilt	44
adjusting suspension and seat height.....	42
adjusting vertical dampener.....	43
fore-aft isolator lock	44
operator's station.....	39, 325
AM/FM radio.....	62
amenities.....	60
climate controls	57
console	39
emergency exit	59
engine controls and gauges.....	65
GSL adjustments	327
adjusting GSL fore-aft movement	327
adjusting GSL lateral movement	327
header controls	68

INDEX

HID lighting (optional)	53
horn	64
interior light	58
lighting	49–50, 52
operator presence system	41, 325
engine and transmission	41
header drive	41
parking brake	330
rearview mirror	55
safety systems	325
seat belts	47, 325
steering adjustments	328
steering column	48
training seat	46
windrower controls	66
windshield wiper	54
options and attachments	461
automated steering systems	461
booster spring kit (internal)	465
cab	
AM/FM radio	461
windshield shades	461
center-link	
hydraulic	464
mechanical	464
draper header case drain kit	463
draper header reel drive and lift plumbing	463
engine	
block heater	462
engine fan air baffle	462
header drive reverser	463
hydraulic	
hydraulic center-link	464
rotary header drive hydraulics	464
light header flotation	464
lighting	
HID auxiliary lighting	461
lighting/marketing for cab-forward travel	466
warning beacons	461
pressure sensor kit	464
R1 disc drive kit (B4657)	464
self-aligning center-link	465
spring with external booster spring kit	465
swath compressor	465
swath roller	465
transport	
lighting/marketing for cab-forward travel	466
towing harness	466
weight box	466
weight box	189
ORB	
definition	25
owner/operator responsibilities	155

P

platforms	318
closing platform (major service position)	322
closing platform (standard position)	319
opening platform (major service position)	320
opening platform (standard position)	318
product overview	25
programming	
auto raise height feature	214
return to cut-feature	212
programming the CDM, <i>See</i> cab display module (CDM)	

R

R Series headers	310
attaching	267
hydraulic center-link with optional self-alignment kit	267
hydraulic center-link without self-alignment kit	272
setting disc speed	311
R Series Rotary Disc Headers	
disc speed	311
R1 Series headers	310
attaching	267
R1 SP	
attaching	
hydraulic center-link with optional self-alignment kit	267
R1 SP Series headers	
attaching	
hydraulic center-link without self-alignment kit	272
radiators	
inspecting radiator cap	364
radios	62, 461
rearview mirrors	55
reel height	
D Series header	290
D1 Series header	290
reel index	291
reel minimum speed	291
reel speed	291
A30D header	304
A40D header	304
D Series header	291
D1 Series header	291
reel-to-ground speed	291
reels	
reel drop rate	423
reference	
torque specifications	467
relays	
replacing	410

INDEX

- return to cut feature 211
 - programming return to cut 212
 - using return to cut 213
- RoHS
 - definition 25
- rpm
 - definition 25
- S**
- SAE
 - bolt torques 467
 - definition 25
- safety
 - battery safety 8
 - engine safety 10
 - engine electronics 11
 - high-pressure rail 11
 - general safety 3
 - hydraulic safety 6
 - maintenance safety 5
 - operational safety 159
 - safety alert symbols 1
 - safety sign decals 12
 - installing decals 12
 - interpreting decals 17
 - sign location 13
 - signal words 2
 - tire safety 7
 - welding precautions 9
- safety props
 - M Series Windrower 196
- screen cleaners
 - adjusting clearance 374
- screws
 - definition 25
- SDD
 - definition 25
- seat belts 47
 - maintaining seat belts 325
- self-propelled windrowers
 - definition 25
- serial numbers
 - location vi
- shutting down the engine 165
- SK
 - definition 25
- SKD
 - definition 25
- soft joints
 - definition 25
- specifications 28
 - filter part numbers 480
 - fuel 478
 - torque specifications 467
 - windrower dimensions 32
- spm
 - definition 25
- springs
 - float springs
 - spring with internal booster spring kit 465
- starting the engine 162
 - engine warm-up 164
- steering
 - adjusting steering chain tension 330
 - adjusting steering column 48
 - adjustments 328
 - automated steering systems (option) 461
 - checking steering chain tension 330
 - checking steering link pivots 328
- storing the windrower 195
- swath compressors
 - activating swath compressor 105
 - calibrating sensor 130
 - controls and automated functions 216
 - using swath compressor 215
- symbols
 - definitions 156
 - engine function 156
 - header function 158
 - windrower operating 157
- T**
- temperature
 - cab 56
 - engine 167
- TFFT
 - definition 25
- torque
 - definition 25
- torque angles
 - definition 25
- torque specifications 467
 - flare-type hydraulic fittings 472
 - metric bolt specifications 469
 - bolting into cast aluminum 471
 - O-ring boss (ORB) hydraulic fittings – adjustable 473
 - O-ring boss (ORB) hydraulic fittings – non-adjustable 475
 - O-ring face seal (ORFS) fittings 476
 - SAE bolt torque specifications 467
 - tapered pipe thread fittings 477
- torque-tension
 - definition 25
- towing
 - attaching tow-bar to windrower 189
 - towing header with windrower 183
- towing harness 466
- towing headers

INDEX

weight box.....	466
towing windrower	193
engaging and disengaging final drives	194
training seats.....	46
transporting	
attaching header transport hitch to header.....	189
converting from field to transport mode	184
converting from transport to field mode	187
Trimble® automated steering systems	461
troubleshooting	
cab air.....	457
electrical.....	451
engine.....	447
header drive.....	453
header problems.....	138
hydraulics	452
operator's station	460
steering and ground speed control	456
traction drive	454
windrower problems	131
turn signal indicators.....	409

U

UCA	
definition.....	25
ULSD	
definition.....	25

V

ventilating, *See* HVAC systems

W

washers	
definition.....	25
WCM	
definition.....	25
weight boxes	466
attaching to windrower	189
welding.....	9
wheels and tires.....	426
caster wheels	178, 433
anti-shimmy dampener.....	440
ballast requirement.....	441
forked caster wheels	
installing	438
lowering	437
raising	435
removing	437
formed caster wheels	
installing	439
lowering	437

raising	435
removing	439
inflating caster tire.....	433
servicing.....	435
tightening caster wheel nuts.....	434
drive wheels	
inflating drive tire	426
lowering.....	433
nut tightening procedure	427
raising.....	430
removing.....	431
servicing.....	430
safety.....	7
wheel drive	
checking lubricant levels	427
lubricating wheel drive	427
adding lubricant	428
changing lubricant	429
windrower control module (WCM)	
calibrating header sensors	124
windrowers	
definition.....	25
windshield wipers.....	54

Lubricants, Fluids, and System Capacities



To avoid injury or death, do NOT allow ANY machine fluids to enter the body.

Lubricant/Fluid	Location	Description	Capacity
Grease	As required unless otherwise specified	SAE multi-purpose high temperature extreme pressure (EP2) performance with 1% max Molybdenum Disulphide (NLGI Grade 2) lithium base	—
Diesel fuel	Fuel tank	Diesel Grade No.2, or Diesel Grade No.1 and 2 mix ⁸³ ; refer to 8.2.2 Fuel Specifications, page 478 for more information	378 liters (97 US gallons)
Hydraulic oil	Hydraulic reservoir	SAE 15W-40 compliant with SAE specs for API class SJ and CH-4 engine oil.	65 liters (17.2 US gallons)
Gear lubricant	Gearbox	SAE 80W-140 ⁸⁴ , API service class GL-5. Fully synthetic gear lubricant, (SAE J2360 preferred)	2.1 liters (2.2 US quarts)
Gear lubricant	Wheel drive ⁸⁵	SAE 75W-90, API service class GL-5. Fully synthetic gear lubricant, (SAE J2360 preferred)	1.4 liters (1.5 US quarts)
Antifreeze	Engine cooling system	ASTM D-6210 and Fleetguard [®] ES Compleat [™] ; refer to 8.2.3 Lubricants, Fluids, and System Capacities, page 479	27.5 liters (7.3 US gallons) ⁸⁶
Engine oil	Engine oil pan	SAE 15W-40 compliant with SAE specs for API class SJ and CH-4 engine oil	11 liters (11.6 US quarts)
Air conditioning refrigerant ⁸⁷	Air conditioning system	R134A	2.27 kg (5 lb.)
Air conditioning refrigerant oil ⁸⁸	Air conditioning system total capacity	PAG SP-15	240 cc (8.1 fl. oz.)

83. Optional when operating temperature is below 0°C (32°F).

84. SAE 75W-140 may be substituted for SAE 80W-140 if necessary.

85. SAE 85W-140 API Service Class GL-5. Extreme Pressure Gear Lubricant is used before initial change.

86. Equal parts with water, high quality, soft, de-ionized or distilled water as recommended by Supplier.

87. For prior models who have not upgraded to 2.27 kg (5 lb.) of refrigerant order Kit MD #183180, which includes decal to advise of systems 2.27 kg (5 lb.) charge requirement. Refer to Service Bulletin 1254.

88. New compressor (MD #203013) comes filled. If installing on 2014 and prior models, refer to Service Bulletin 1254.

MacDon Industries Ltd.

680 Moray Street
Winnipeg, Manitoba
Canada R3J 3S3
t. (204) 885-5590 f. (204) 832-7749

MacDon, Inc.

10708 N. Pomona Avenue
Kansas City, Missouri
United States 64153-1924
t. (816) 891-7313 f. (816) 891-7323

MacDon Australia Pty. Ltd.

A.C.N. 079 393 721
P.O. Box 103 Somerton, Victoria, Australia
Australia 3061
t.+61 3 8301 1911 f.+61 3 8301 1912

MacDon Brasil Agribusiness Ltda.

Rua Grã Nicco, 113, sala 404, B. 04
Mossunguê, Curitiba, Paraná
CEP 81200-200 Brasil
t. +55 (41) 2101-1713 f. +55 (41) 2101-1699

LLC MacDon Russia Ltd.

123317 Moscow, Russia
10 Presnenskaya nab, Block C
Floor 5, Office No. 534, Regus Business Centre
t. +7 495 775 6971 f. +7 495 967 7600

MacDon Europe GmbH

Hagenauer Strasse 59
65203 Wiesbaden
Germany

CUSTOMERS

MacDon.com

DEALERS

Portal.MacDon.com

Trademarks of products are the marks of their
respective manufacturers and/or distributors.

Printed in Canada