

M155E4 **Self-Propelled Windrower**

Unloading and Assembly Instructions (North America)

147950 Revision A
2017 Model Year
Original Instruction

Featuring the Dual Direction® and Ultra Glide® suspension on the M155E4.

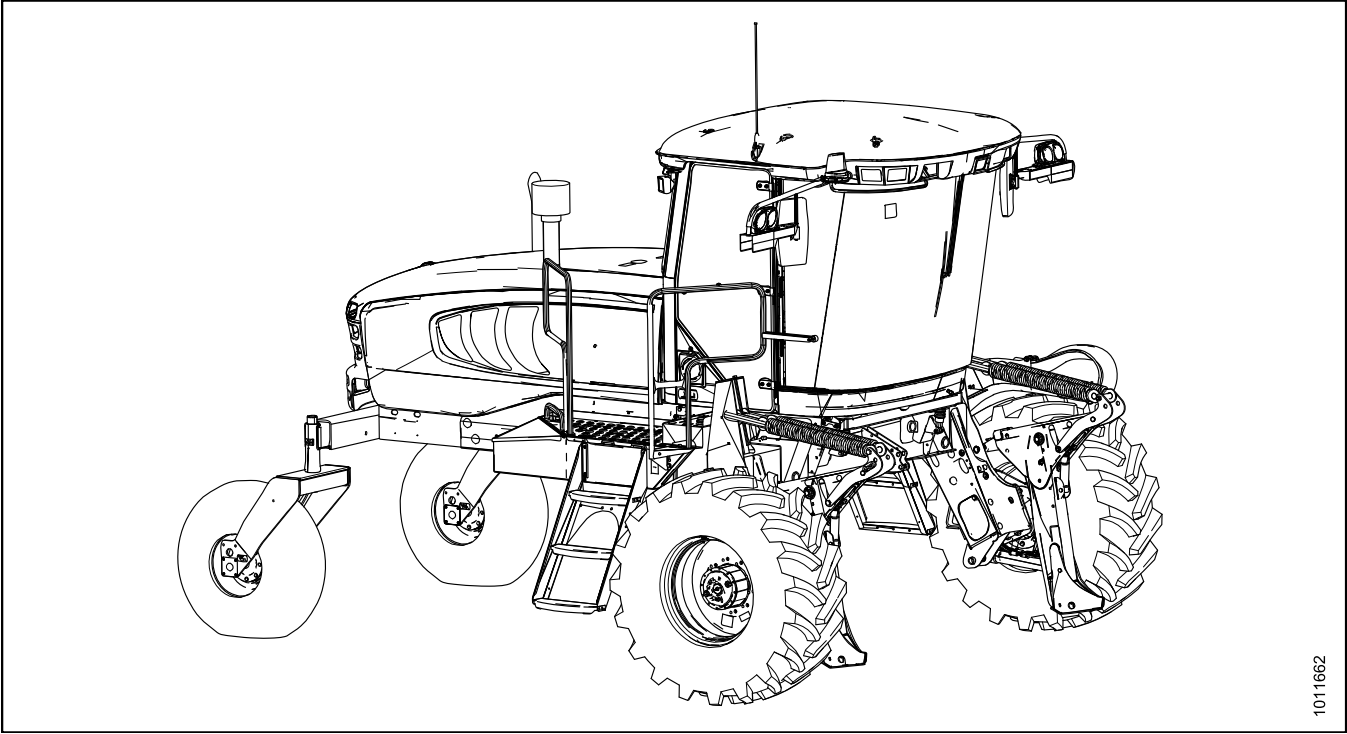

1011662

Published in June, 2016

Introduction

This instruction manual describes the unloading, setup, and predelivery requirements for the MacDon M155E4 Self-Propelled Windrowers.

Carefully read all the material provided before attempting to unload, assemble, or use the machine.

Retain this instruction for future reference.

Conventions

The following conventions are used in this document: Right- and left-hand are determined from the operator's position. The front of the windrower is the side that faces the crop.

NOTE:

Keep your MacDon publications up-to-date. The most current version can be downloaded from our website (www.macdon.com) or from our Dealer-only site (<https://portal.macdon.com>) (login required).

List of Revisions

The following list provides an account of major changes from the previous version of this document.

Summary of Change	Location
Removed a step and updated illustration to point to the right part.	5.9 Checking Gearbox Lubricant Level, page 142
Added an important note about optional red tail lighting and marking kit.	5.12.7 Checking Exterior Lights, page 151
Changed topic title (from Connecting Batteries) and revised procedure.	3.5 Activating the Battery Main Switch, page 18
Added a step to remove shipping stand from lift legs.	3.2 Installing Drive Wheel, page 13
Added a step to remove banding and wooden blocks from center of walking beam.	3.3 Repositioning Caster Wheels, page 15
Revised Intermediate Speed Control (ISC).	4.4.15 Setting the Engine Intermediate Speed Control (ISC) RPM, page 94
Added procedure	5.8 Draining and Refilling the Diesel Exhaust Fluid (DEF) Tank, page 140
Added a step to add fuel, fluids, or lubricants.	<ul style="list-style-type: none"> • 5.2 Checking Wheel Drive Lubricant Level, page 132 • 5.5 Checking Hydraulic Oil, page 137 • 5.7 Checking Engine Coolant, page 139 • 5.9 Checking Gearbox Lubricant Level, page 142
Removed the procedure for unpacking ignition keys, as this does not apply.	—
Changed measurement format so that metric appear first followed by imperial in parenthesis.	Throughout the book

TABLE OF CONTENTS

Introduction	i
List of Revisions	ii
1 Safety	1
1.1 Signal Words	1
1.2 General Safety	2
1.3 Battery Safety	4
1.4 Safety Signs	5
2 Unloading the Windrower	7
2.1 Using Two Forklifts to Unload Windrower	7
2.2 Using One Forklift to Unload Windrower	9
2.2.1 Method 1: Pulling from Trailer Deck	9
2.2.2 Method 2: Lifting from Trailer Deck	10
3 Assembling the Windrower	11
3.1 Repositioning Right Leg	11
3.2 Installing Drive Wheel	13
3.3 Repositioning Caster Wheels	15
3.4 Installing Steps	17
3.5 Activating the Battery Main Switch	18
3.6 Starting Engine	19
3.7 Installing AM/FM Radio	22
3.8 Installing the Slow Moving Vehicle (SMV) Sign	26
3.9 Attaching Headers	27
3.9.1 Attaching Header Boots	27
3.9.2 Attaching a D-Series Header	28
Attaching a D-Series Header: Hydraulic Center-Link with Optional Self-Alignment	28
Attaching a D-Series Header: Hydraulic Center-Link without Self-Alignment	33
3.9.3 Attaching an A-Series Header	39
Attaching an A-Series Header: Hydraulic Center-Link with Optional Self-Alignment	40
Attaching an A-Series Header: Hydraulic Center-Link without Self-Alignment	45
3.9.4 Attaching an R-Series Header	51
Attaching an R-Series Header: Hydraulic Center-Link with Optional Self-Alignment	51
Attaching an R-Series Header: Hydraulic Center-Link without Self-Alignment	56
3.10 Lubricating the Windrower	62
3.10.1 Lubrication Procedure	62
3.10.2 Lubrication Points	63
3.11 Fuel and Diesel Exhaust Fluid (DEF) Display Module	64
4 Cab Display Module (CDM)	67
4.1 Cab Display Module (CDM) Programming	67
4.2 Cab Display Options	69
4.2.1 Setting the Cab Display Language	69
4.2.2 Changing the Windrower Display Units	70
4.2.3 Adjusting the Cab Display Buzzer Volume	71
4.2.4 Adjusting the Cab Display Backlighting	72
4.2.5 Adjusting the Cab Display Contrast	73
4.3 Calibrating the Header Sensors	75
4.3.1 Calibrating the Header Height Sensor	75
4.3.2 Calibrating the Header Tilt Sensor	77
4.3.3 Calibrating the Header Float Sensors	79
4.4 Programming the Windrower	81
4.4.1 Activating the Hydraulic Center-Link	81
4.4.2 Activating the Rotary Header Drive Hydraulics	81
4.4.3 Setting the Header Knife Speed	82
4.4.4 Setting the Knife Overload Speed	83

TABLE OF CONTENTS

4.4.5	Setting the Rotary Disc Overload Speed	84
4.4.6	Setting the Hydraulic Overload Pressure	85
4.4.7	Setting the Header Index Mode	86
4.4.8	Setting the Return to Cut Mode	87
4.4.9	Setting the Header Cut Width	88
4.4.10	Activating the Double Windrow Attachment (DWA)	88
4.4.11	Setting the Auto Raise Height	90
4.4.12	Activating the Hay Conditioner	91
4.4.13	Displaying Reel Speed	92
4.4.14	Setting the Windrower's Tire Size	93
4.4.15	Setting the Engine Intermediate Speed Control (ISC) RPM	94
4.4.16	Clearing Sub-Acres	95
4.5	Activating Cab Display Lockouts	96
4.5.1	Activating Knife Speed Control Lockout	96
4.5.2	Activating Rotary Disc Speed Control Lockout	97
4.5.3	Activating the Header Float Control Lockout	98
4.5.4	Activating the Draper Speed Control Lockout	99
4.5.5	Activating the Auger Speed Control Lockout	101
4.5.6	Activating the Reel Speed Control Lockout	102
4.5.7	Activating the Reel Fore-Aft Control Lockout	103
4.5.8	Activating the Header Tilt Control Lockout	104
4.6	Displaying Activated Cab Display Lockouts	105
4.7	Troubleshooting Windrower Problems	107
4.7.1	Displaying the Windrower and Engine Error Codes	107
4.7.2	Switching the Installed Header Sensors ON or OFF	108
4.7.3	Displaying Header Sensor Input Signals	109
4.7.4	Forcing a Header ID	111
4.8	Troubleshooting Header Problems	113
4.8.1	Testing the Header Up/Down Activate Function Using the Cab Display Module (CDM)	113
4.8.2	Testing the Reel Up/Down Activate Function Using the Cab Display Module (CDM)	114
4.8.3	Testing the Header Tilt Activate Function Using the Cab Display Module (CDM)	116
4.8.4	Testing the Reel Fore-Aft Activate Function Using the Cab Display Module (CDM)	118
4.8.5	Activating the Hydraulic Purge Using the Cab Display Module (CDM)	119
4.8.6	Testing the Knife Drive Circuit Using the Cab Display Module (CDM)	121
4.8.7	Testing the Draper Drive Circuit Activate Function Using the Cab Display Module (CDM)	123
4.8.8	Testing the Reel Drive Circuit Activate Function Using the Cab Display Module (CDM)	124
4.8.9	Testing the Rotary Disc Drive Circuit Activate Function Using the Cab Display Module (CDM)	126
4.8.10	Testing the Double Windrower Attachment (DWA) Drive Activate Function Using the Cab Display Module (CDM)	128
5	Performing Predelivery Checks	131
5.1	Recording Serial Numbers	131
5.2	Checking Wheel Drive Lubricant Level	132
5.3	Checking Tire Pressures and Adding Tire Ballast	133
5.3.1	Checking Tire Pressures	133
5.3.2	Adding Tire Ballast	133
5.4	Checking Engine Air Intake	135
5.5	Checking Hydraulic Oil	137
5.6	Checking Fuel Separator	138
5.7	Checking Engine Coolant	139
5.8	Draining and Refilling the Diesel Exhaust Fluid (DEF) Tank	140
5.9	Checking Gearbox Lubricant Level	142
5.10	Checking Air Conditioning (A/C) Compressor Belts	143
5.11	Checking Safety System	144

TABLE OF CONTENTS

5.12	Performing Operational Checks	146
5.12.1	Checking Engine Warning Lights	146
5.12.2	Checking Windrower Startup	147
5.12.3	Checking Engine Speed	147
5.12.4	Checking Gauges and Cab Display Module (CDM) Display	148
5.12.5	Checking Electrical System	148
5.12.6	Checking Operator's Presence System	149
5.12.7	Checking Exterior Lights	151
	Auto Road Light	153
5.12.8	Checking Horn	154
5.12.9	Checking Interior Lights	154
5.12.10	Checking Air Conditioning (A/C) and Heater	155
5.13	Checking Manuals	156
5.14	Performing Final Steps	157
6	Reference	159
6.1	Torque Specifications	159
6.1.1	SAE Bolt Torque Specifications	159
6.1.2	Metric Bolt Specifications	161
6.1.3	Metric Bolt Specifications Bolting into Cast Aluminum	164
6.1.4	Flare-Type Hydraulic Fittings	164
6.1.5	O-Ring Boss (ORB) Hydraulic Fittings (Adjustable)	166
6.1.6	O-Ring Boss (ORB) Hydraulic Fittings (Non-Adjustable)	168
6.1.7	O-Ring Face Seal (ORFS) Hydraulic Fittings	169
6.1.8	Tapered Pipe Thread Fittings	171
6.2	Conversion Chart	172
6.3	Definitions	173
	Predelivery Checklist	177

1 Safety

1.1 Signal Words

Three signal words, **DANGER**, **WARNING**, and **CAUTION**, are used to alert you to hazardous situations. The appropriate signal word for each situation has been selected using the following guidelines:

DANGER

Indicates an imminently hazardous situation that, if not avoided, will result in death or serious injury.

WARNING

Indicates a potentially hazardous situation that, if not avoided, could result in death or serious injury. It may also be used to alert against unsafe practices.

CAUTION

Indicates a potentially hazardous situation that, if not avoided, may result in minor or moderate injury. It may be used to alert against unsafe practices.

1.2 General Safety

CAUTION

The following are general farm safety precautions that should be part of your operating procedure for all types of machinery.

Protect yourself.

- When assembling, operating, and servicing machinery, wear all the protective clothing and personal safety devices that could be necessary for the job at hand. Do **NOT** take chances. You may need the following:
 - Hard hat
 - Protective footwear with slip resistant soles
 - Protective glasses or goggles
 - Heavy gloves
 - Wet weather gear
 - Respirator or filter mask
- Be aware that exposure to loud noises can cause hearing impairment or loss. Wear suitable hearing protection devices such as ear muffs or ear plugs to help protect against objectionable or loud noises.

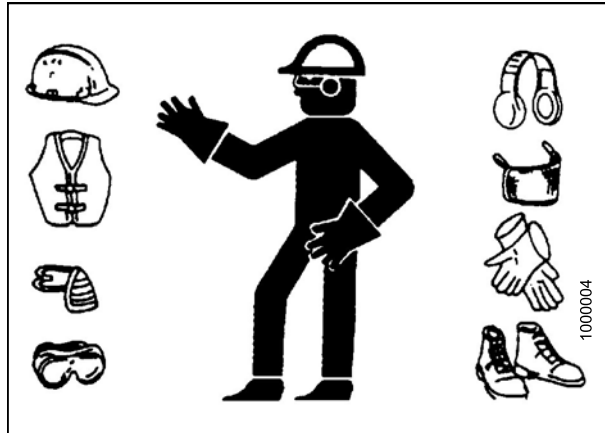

Figure 1.1: Safety Equipment



Figure 1.2: Safety Equipment

- Provide a first aid kit for use in case of emergencies.
- Keep a fire extinguisher on the machine. Be sure the fire extinguisher is properly maintained. Be familiar with its proper use.
- Keep young children away from the machinery at all times.
- Be aware that accidents often happen when the Operator is tired or in a hurry. Take the time to consider the safest way. Never ignore the warning signs of fatigue.

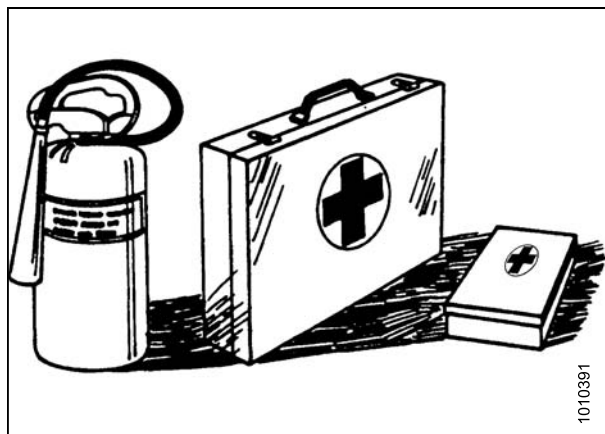

Figure 1.3: Safety Equipment

SAFETY

- Wear close-fitting clothing and cover long hair. Never wear dangling items such as scarves or bracelets.
- Keep all shields in place. **NEVER** alter or remove safety equipment. Make sure driveline guards can rotate independently of the shaft and can telescope freely.
- Use only service and repair parts made or approved by the equipment manufacturer. Substituted parts may not meet strength, design, or safety requirements.



Figure 1.4: Safety around Equipment

- Keep hands, feet, clothing, and hair away from moving parts. **NEVER** attempt to clear obstructions or objects from a machine while the engine is running.
- Do **NOT** modify the machine. Non-authorized modifications may impair machine function and/or safety. It may also shorten the machine's life.
- To avoid bodily injury or death from unexpected startup of machine, **ALWAYS** stop the engine and remove the key from ignition before leaving operator's seat for any reason.

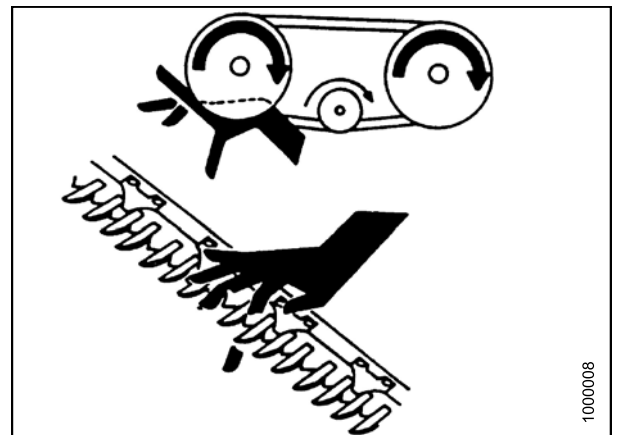

Figure 1.5: Safety around Equipment

- Keep the service area clean and dry. Wet or oily floors are slippery. Wet spots can be dangerous when working with electrical equipment. Be sure all electrical outlets and tools are properly grounded.
- Keep work area well lit.
- Keep machinery clean. Straw and chaff on a hot engine is a fire hazard. Do **NOT** allow oil or grease to accumulate on service platforms, ladders, or controls. Clean machines before storage.
- **NEVER** use gasoline, naphtha, or any volatile material for cleaning purposes. These materials may be toxic and/or flammable.
- When storing machinery, cover sharp or extending components to prevent injury from accidental contact.



Figure 1.6: Safety around Equipment

1.3 Battery Safety

WARNING

- Keep all sparks and flames away from the batteries, as a gas given off by electrolyte is explosive.
- Ventilate when charging in enclosed space.

WARNING

- Wear safety glasses when working near batteries.
- Do NOT tip batteries more than 45° to avoid electrolyte loss.
- Battery electrolyte causes severe burns. Avoid contact with skin, eyes, or clothing.
- Electrolyte splashed into the eyes is extremely dangerous. Should this occur, force the eye open, and flood with cool, clean water for five minutes. Call a doctor immediately.
- If electrolyte is spilled or splashed on clothing or the body, neutralize it immediately with a solution of baking soda and water, then rinse with clear water.

WARNING

- To avoid injury from spark or short circuit, disconnect battery ground cable before servicing and part of electrical system.
- Do NOT operate the engine with alternator or battery disconnected. With battery cables disconnected and engine running, a high voltage can be built up if terminals touch the frame. Anyone touching the frame under these conditions would be severely shocked.
- When working around storage batteries, remember that all of the exposed metal parts are live. Never lay a metal object across the terminals because a spark or short circuit will result.
- Keep batteries out of reach of children.



Figure 1.7: Safety around Batteries

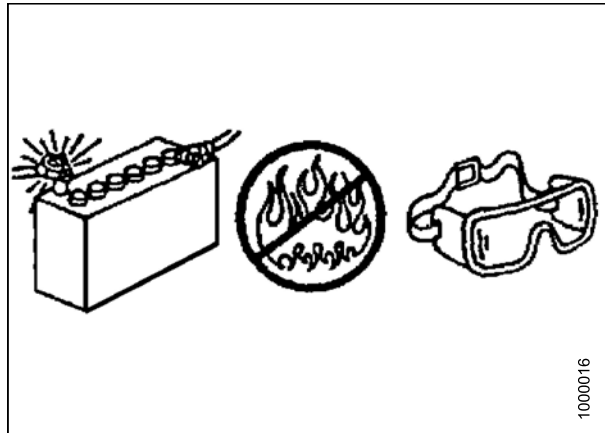

Figure 1.8: Safety around Batteries

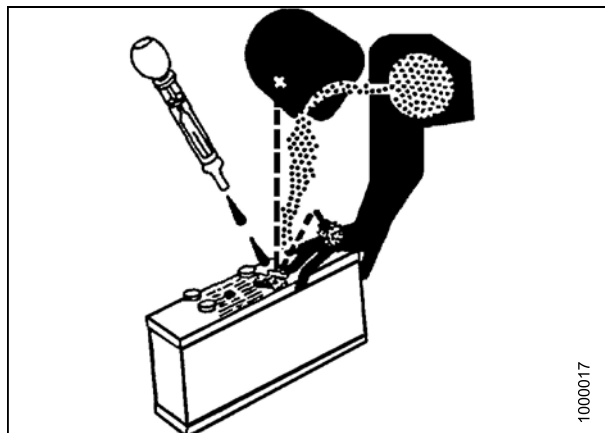

Figure 1.9: Safety around Batteries

1.4 Safety Signs

- Keep safety signs clean and legible at all times.
- Replace safety signs that are missing or become illegible.
- If original parts on which a safety sign was installed are replaced, be sure the repair part also bears the current safety sign.
- Safety signs are available from your MacDon dealer.

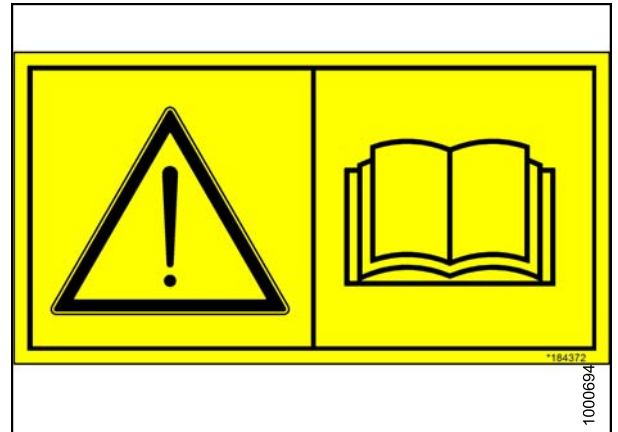

Figure 1.10: Operator's Manual Decal

2 Unloading the Windrower

2.1 Using Two Forklifts to Unload Windrower



Figure 2.1: Two-Forklift Unloading Method

CAUTION

To prevent injury to bystanders and avoid striking them with machinery, do NOT allow people to stand in the unloading area.

CAUTION

Equipment used for unloading must meet or exceed the specified requirements. Using inadequate equipment may result in chain breakage, vehicle tipping, or machine damage.

Table 2.1 Lifting Vehicle Requirements

Minimum Lifting Capacity ¹	2500 kg (5500 lb.)
Minimum Fork Length	1981 mm (78 in.)

IMPORTANT:

Forklifts are normally rated for a load located 610 mm (24 in.) ahead of the back end of the forks. To obtain forklift capacity at 1220 mm (48 in.), check with your forklift distributor.

1. Move the trailer onto level ground and block the trailer wheels.
2. Set forklift tines to the widest possible setting.
3. Position one forklift on either side of the trailer, and position the forks under the windrower frame.

1. At 1220 mm (48 in.) from back end of forks.

UNLOADING THE WINDROWER

NOTE:

The windrower's center of gravity is approximately 1397 mm (55 in.) rearwards from the center of the drive wheel.

4. Lift with both forklifts simultaneously until the windrower is clear of the trailer deck.



WARNING

Ensure the forks are secure before moving the trailer away from the load. Stand clear when lifting.

5. Drive truck slowly forward until trailer deck is clear of windrower.
6. Lower unit slowly to the ground using both forklifts simultaneously. If the ground is soft, place wooden blocks under the front shipping stands.
7. Back off forklifts.
8. Check windrower for shipping damage, and check shipment for missing parts.

2.2 Using One Forklift to Unload Windrower

There are two different methods for unloading a windrower using one forklift. If using a chain to pull the windrower to a ground level that is equal to, or slightly lower than the height of the trailer deck, refer to [2.2.1 Method 1: Pulling from Trailer Deck, page 9](#). If lifting the windrower from the left or right side of the trailer deck, refer to [2.2.2 Method 2: Lifting from Trailer Deck, page 10](#).

2.2.1 Method 1: Pulling from Trailer Deck

CAUTION

Equipment used for unloading must meet or exceed the specified requirements. Using inadequate equipment may result in chain breakage, vehicle tipping, or machine damage.

Table 2.2 Lifting Vehicle Requirements

Minimum Capacity ²	2500 kg (5500 lb.)
-------------------------------	--------------------

IMPORTANT:

Forklifts are normally rated for a load located 610 mm (24 in.) ahead of the back end of the forks. To obtain forklift capacity at 1220 mm (48 in.), check with your forklift distributor.

Table 2.3 Pulling Chain Requirements

Type	Overhead lifting quality (1/2 in.)
Minimum Working Load	2270 kg (5000 lb.)

1. Position the rear of the trailer against an unloading dock that is the same height, or slightly lower than, the trailer deck.
2. Remove shipped parts from underneath the windrower frame.
3. Set forklift tines to the widest possible setting.
4. Drive forklift up to the rear of the windrower and place forks under the rear frame cross member.
5. Install chains between the forklift mast and the jacking brackets on both front legs of the windrower. Chains must be the same length.

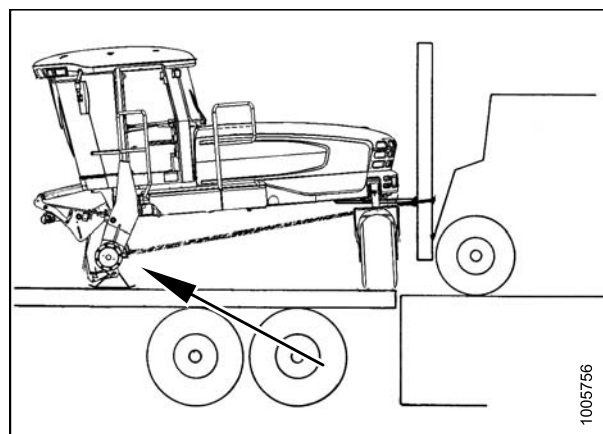

Figure 2.2: Chain Installation Location

CAUTION

The front legs rest on the trailer deck on skid shoes. Ensure there are no obstructions preventing the skid shoes from sliding rearwards, and watch carefully while dragging the unit to ensure the skid shoes do not slide sideways towards the edge of the trailer deck.

6. Drag the windrower rearwards off of carrier.
7. Remove chains and back off the forklift.
8. Check windrower for shipping damage, and check shipment for missing parts.

2. At 1220 mm (48 in.) from back end of forks.

UNLOADING THE WINDROWER

2.2.2 Method 2: Lifting from Trailer Deck

CAUTION

Equipment used for unloading must meet or exceed the specified requirements. Using inadequate equipment may result in chain breakage, vehicle tipping, or machine damage.

Table 2.4 Lifting Vehicle Requirements

Minimum Capacity ³	4994 kg (11,000 lb.)
Minimum Fork Length	1981 mm (78 in.)

IMPORTANT:

Forklifts are normally rated for a load located 610 mm (24 in.) ahead of the back end of the forks. To obtain forklift capacity at 1220 mm (48 in.), check with your forklift distributor.

WARNING

Ensure the forks are secure before moving the trailer away from the load. Stand clear when lifting.

1. Move the trailer onto level ground and block the trailer wheels.
2. Set forklift tines to the widest possible setting.
3. Position forklift on left or right side of trailer, and position forks (A) under windrower frame.

NOTE:

The windrower's center of gravity is approximately 1397 mm (55 in.) rearwards from the center of the drive wheel.



Figure 2.3: Windrowers on Trailer

WARNING

Ensure the forks extend beyond the far side of the frame.

4. Lift until windrower is clear of the trailer deck.
5. Back forklift slowly away from trailer until the windrower is clear of the trailer deck.
6. Lower unit slowly to the ground. If the ground is soft, place wooden blocks under the front shipping stands.
7. Back off forklift.
8. Check windrower for shipping damage, and check shipment for missing parts.

3. At 1220 mm (48 in.) from back end of forks.

3 Assembling the Windrower

Perform all procedures in this chapter in the order in which they are listed.

3.1 Repositioning Right Leg

The right cab-forward leg requires repositioning from shipping to field configuration.

1. Remove two bolts (A), washers, and nuts from frame.

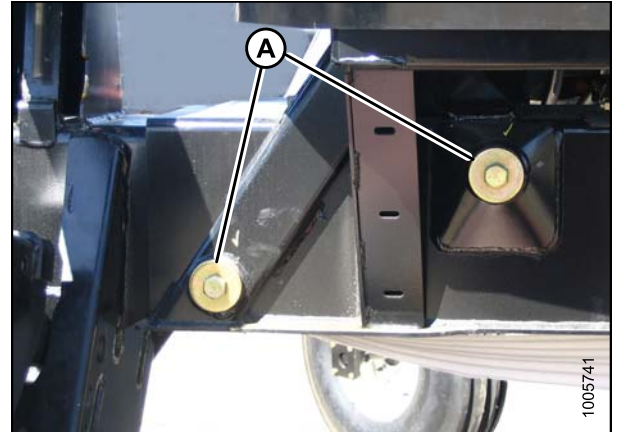

Figure 3.1: Windrower Frame

2. Support the front of the windrower with a stand (A) (or equivalent) so the right leg is off the ground.
3. Position jack (B) under the right leg and slightly raise the jack to take some weight off the leg.

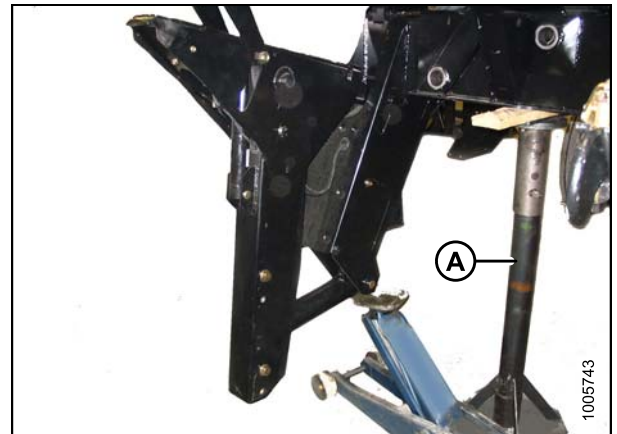

Figure 3.2: Right Leg

4. Adjust jack height until pin (A) is loose. Extract pin from front of frame with a slide hammer or tool (MD #B5442) (B) (due to limited space in front of Diesel Exhaust Fluid [DEF] tank). Instructions are included with the tool.

IMPORTANT:

Removing the pins will be difficult if the jack is not properly positioned to take the weight off the leg.

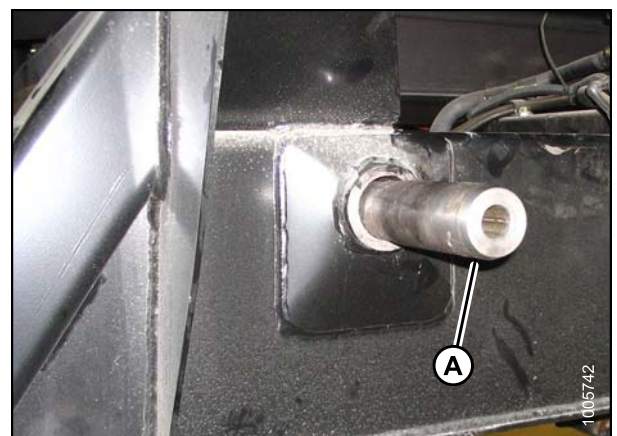

Figure 3.3: Windrower Frame

ASSEMBLING THE WINDROWER

5. Move leg outwards to expose one hole (A).
6. Reinstall pins and secure with bolts (B), washers, and nuts. Torque nuts to 136 N·m (100 ft·lbf).
7. Lower jack and remove it from the right-hand leg.

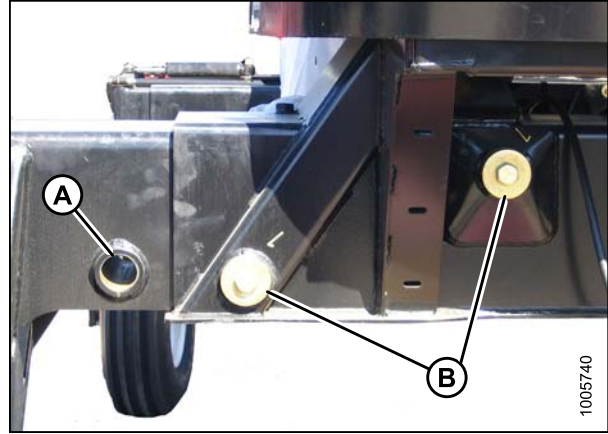

Figure 3.4: Windrower Frame

3.2 Installing Drive Wheel

CAUTION

Use a suitable lifting device capable of supporting a minimum of 907 kg (2000 lb.) to lift the wheel assembly away from the windrower.

1. Support the front of the windrower off the ground using stand (A).
2. Remove shipping stand (B) from lift leg. Repeat at the opposite side.

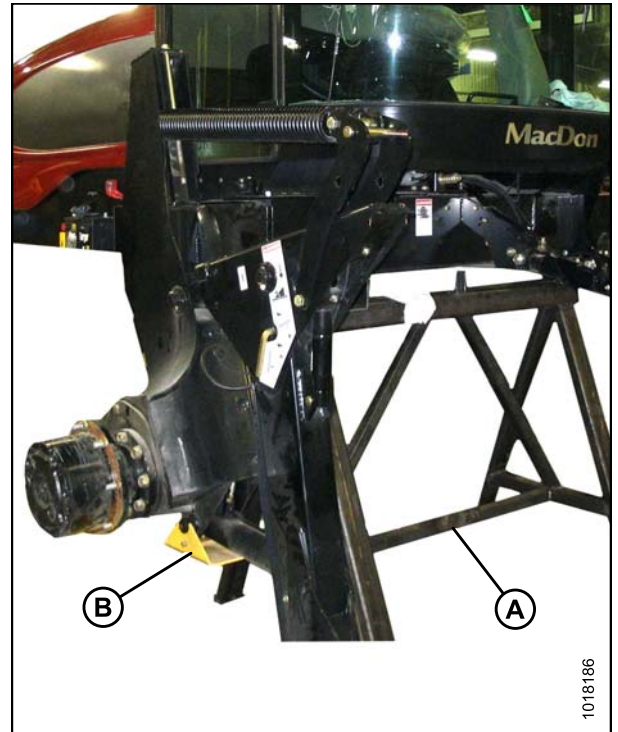

Figure 3.5: Windrower on Stand

3. Position drive wheel (A) against the wheel drive hub (B) so the air valve (C) is on the outside and the tire tread (D) points in cab-forward direction.

NOTE:

For turf tires (diamond tread), be sure arrow on sidewall points in cab-forward rotation.

4. Lift wheel onto hub using a suitable lifting device.
5. Remove the lifting device.

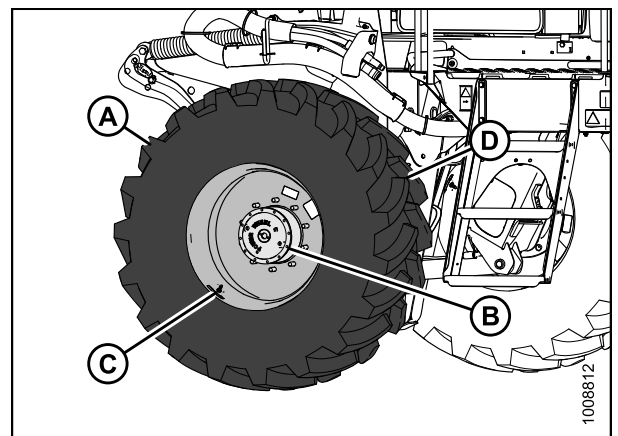

Figure 3.6: Drive Wheel

ASSEMBLING THE WINDROWER

- Line up the holes in the rim with the studs on the wheel drive hub and install wheel nuts (A).

IMPORTANT:

To avoid damage to wheel rims and studs, tighten nuts by hand. Do **NOT** use an impact gun, do **NOT** use lubricant or Never-Seez[®] compound, and do **NOT** overtighten wheel nuts.

- Torque drive wheel nuts to 510 N·m (375 ft·lbf) using the tightening sequence shown.

IMPORTANT:

Use only manufacturer specified nuts (MD #205397).

- Repeat tightening sequence two additional times ensuring the specified torque of 510 N·m (375 ft·lbf) is achieved each time.
- Repeat torque procedure every hour until two consecutive checks confirm there is no movement of the nuts.

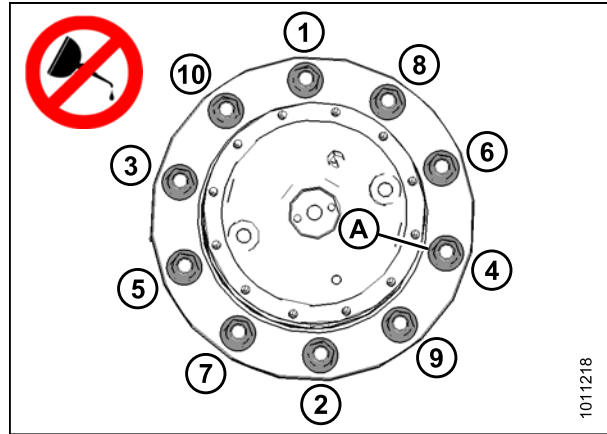

Figure 3.7: Drive Wheel Nuts

3.3 Repositioning Caster Wheels

As an option, the rear casters can be adjusted to a narrow tread width which allows for loading and shipping without having to remove them.

A **narrow tread** width is better suited for smaller headers because it allows more space to the uncut crop and provides more maneuverability around poles, irrigation inlets, and other obstacles.

A **wider tread** width is preferable for reducing run-over in heavy crops that produce large windrows.

1. Raise the rear of the windrower slightly using a jack or other lifting device under the frame at location (A) until most of the weight is off the casters.

NOTE:

Lifting device must have a lifting capacity of at least 2270 kg (5000 lb.).

2. Remove six bolts (B) (four on backside and two on underside) and washers from left and right sides of walking beam.

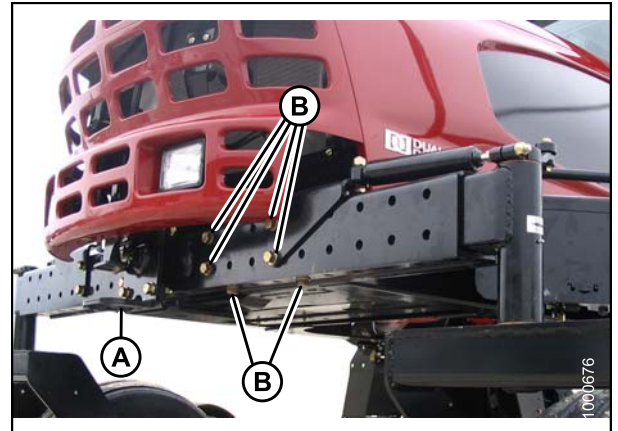

Figure 3.8: Walking Beam

3. Slide left and right side extensions equal distances in the outboard direction, and align holes at the preferred locations.

NOTE:

Rotate the caster so the wheel is parallel to the axle to assist with axle movement.



Figure 3.9: Walking Beam

ASSEMBLING THE WINDROWER

4. Ensure caster wheels are positioned at equal distances from the center of the windrower.

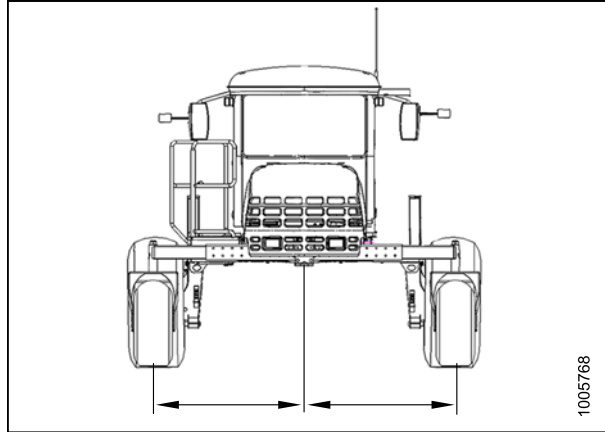

Figure 3.10: Widest Tread Width Shown

5. Position bracket (A) as shown.
6. Install two 3/4 in. x 2-3/4 in. hex head bolts (B) at the back outboard location, and install two 3/4 in. x 2-1/4 in. hex head bolts (C) at the back inboard location.
7. Install two 3/4 in. x 2-1/4 in. hex head bolts (D) to the underside. Tighten bolts snug.
8. Torque all bolts (B and C) at the back location to 447 N·m (330 ft·lbf).
9. Torque all bolts (D) on the underside to 447 N·m (330 ft·lbf).
10. Lower windrower to the ground.

IMPORTANT:

Torque all bolts to 447 N·m (330 ft·lbf) after the first 5 and 10 hours of operation.

11. Remove banding and wooden blocks from center of walking beam.

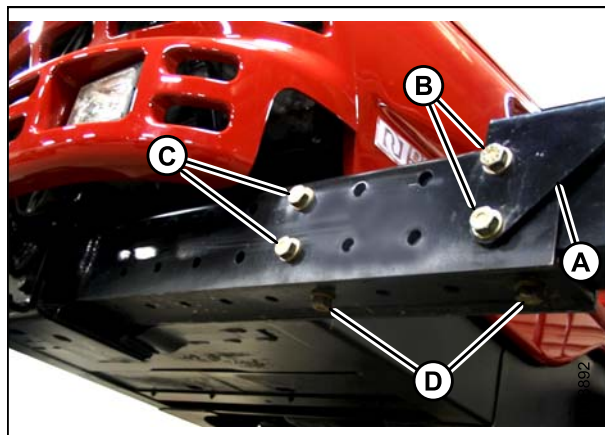

Figure 3.11: Walking Beam

3.4 Installing Steps

NOTE:

Procedure for left-hand installation shown—right-hand installation similar.

1. Remove two bolts (A) securing steps to platform and remove steps.
2. Remove bolt (B) and retain for reinstallation.

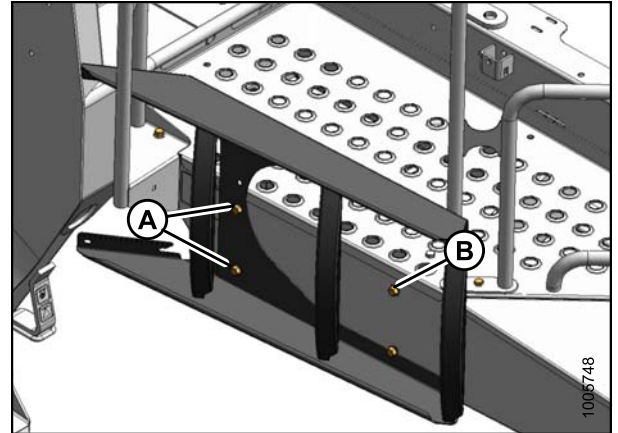

Figure 3.12: Left-Hand Steps in Shipping Position

3. Install bolt (A) into lower hole of platform. Do **NOT** fully thread in bolt.

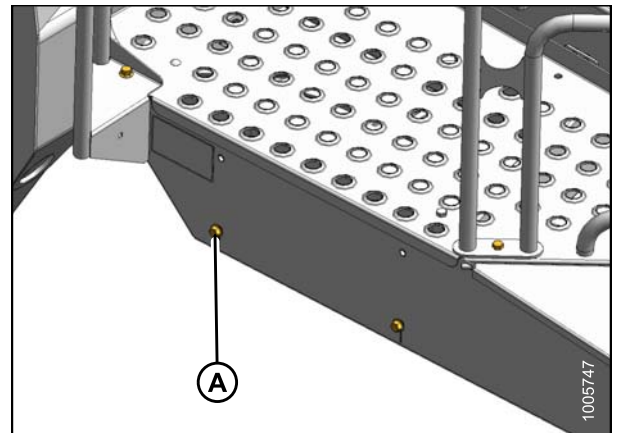

Figure 3.13: Left-Hand Platform

4. Hang step assembly on lower bolts (B) (back off bolts, if necessary).
5. Install two bolts (A) in upper holes of step and platform.
6. Torque all bolts to 20 N·m (15 ft·lbf).
7. Repeat for opposite step assembly.

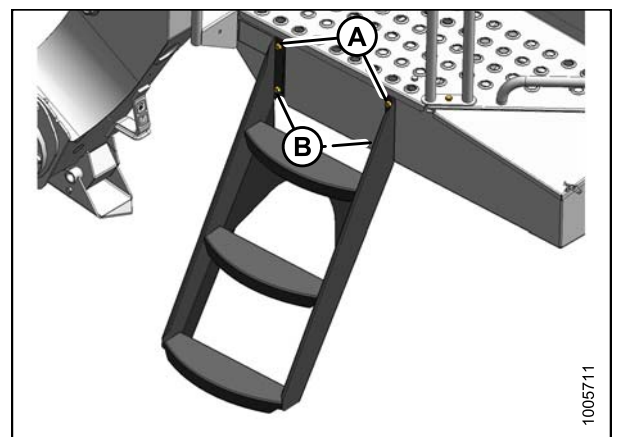

Figure 3.14: Left-Hand Steps Installed

3.5 Activating the Battery Main Switch

1. Open the right-hand (cab-forward) maintenance platform.
2. Turn the battery switch (A) to the POWER ON position.
3. Move the right-hand (cab-forward) maintenance platform forward to the closed position.

IMPORTANT:

Turn the battery switch (A) to the POWER OFF position if the machine will be stored for a week or more.

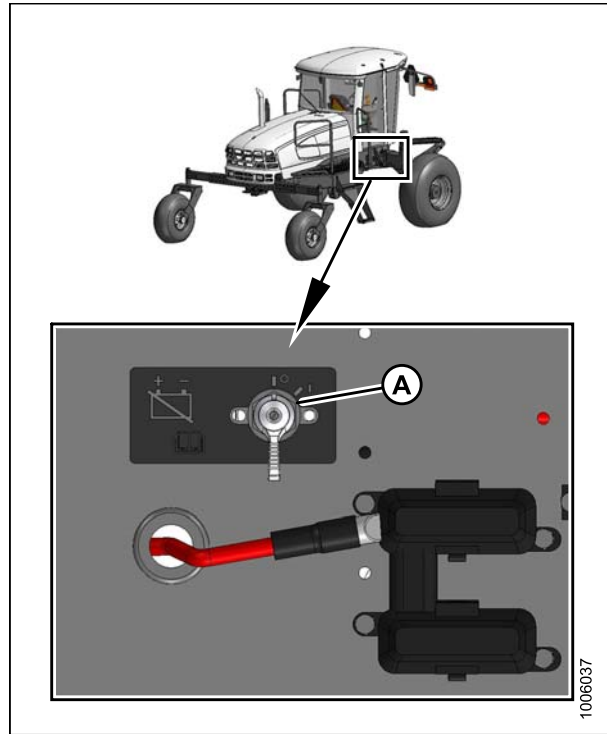

Figure 3.15: Battery Main Disconnect Switch

3.6 Starting Engine

1. Ensure there is sufficient fuel and diesel exhaust fluid (DEF) for a 15 minute run.

NOTE:

Ensure there is sufficient diesel exhaust fluid (DEF) to avoid DEF level warnings. Refer to [3.11 Fuel and Diesel Exhaust Fluid \(DEF\) Display Module, page 64](#).

2. Move the ground speed lever (GSL) (A) into the N-DETENT position.
3. Turn the steering wheel until it locks.
4. Push header drive switch (B) to the OFF position.

⚠ CAUTION

Check to be sure all bystanders have cleared the area.

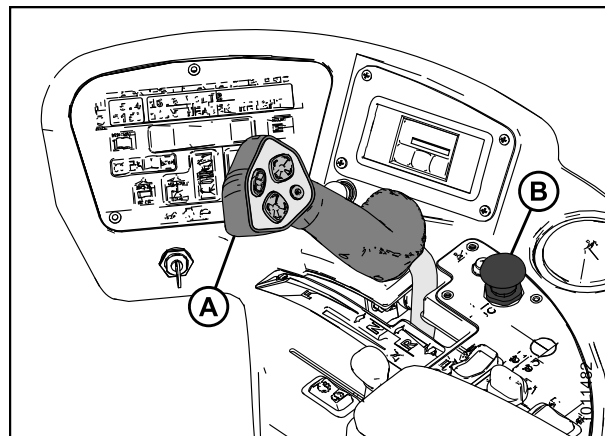

Figure 3.16: Operator Console

Normal Start (All Engines):

5. Follow these steps when starting engine in temperatures above 16°C (60°F):
 - a. Move throttle fully back to START position (A).
 - b. Sound horn three times.
 - c. Turn ignition key (B) to RUN position.

NOTE:

A single loud tone will sound, engine warning lights will illuminate, and the cab display module will display “HEADER DISENGAGED” and “IN PARK”.

⚠ WARNING

If starter engages with steering wheel unlocked, ground speed lever out of NEUTRAL, or header clutch engaged, do NOT start engine. Refer to the technical manual.

- d. Turn ignition key (B) to START position until engine starts and then release the key. The tone will cease and warning lights will go out.

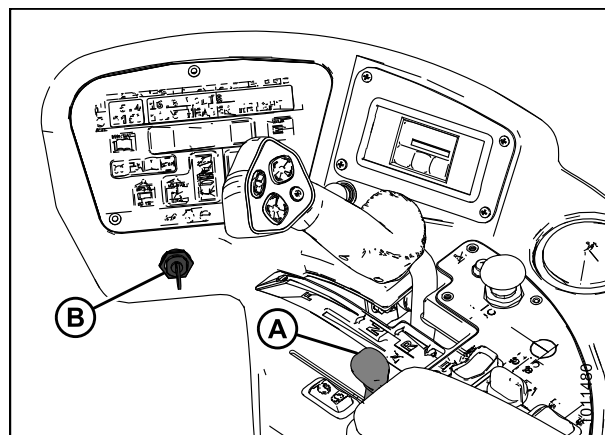

Figure 3.17: Operator Console

ASSEMBLING THE WINDROWER

IMPORTANT:

- Do **NOT** operate starter for longer than 15 seconds at a time.
- If engine does **NOT** start, wait at least 2 minutes before trying again.
- After the third 15 second crank attempt, allow the starter motor to cool for 10 minutes before further cranking attempts.
- If engine still does **NOT** start, refer to Table [3.1 Engine Start Troubleshooting, page 20](#).

Cold Start:

NOTE:

Engines are equipped with cold start assist system.

6. Use cold start for engine temperatures below 5°C (40°F). Refer to Step [5, page 19](#) for engine temperatures below 5°C (40°F), but adhere to the following *NOTE* and *IMPORTANT* statements while starting the engine.

NOTE:

Engine will cycle through a period when it appears to labour during engine warm up. The throttle is nonresponsive while engine is in warm up mode. Warm up mode lasts between 30 seconds and 3 minutes depending on the temperature. The throttle will become active after the engine has stabilized and is idling normally.

IMPORTANT:

Do **NOT** operate engine above 1500 rpm until engine temperature is above 40°C (100°F).

Table 3.1 Engine Start Troubleshooting

Problem	Solution
Controls not in NEUTRAL	<ul style="list-style-type: none"> • Move GSL to NEUTRAL • Move steering wheel to locked position • Disengage header clutch
Operator's station not locked	<ul style="list-style-type: none"> • Adjust position of operator's station • Ensure lock is engaged
Neutral interlock misadjusted	<ul style="list-style-type: none"> • Refer to the windrower technical manual
No fuel to engine	<ul style="list-style-type: none"> • Fill empty fuel tank • Replace clogged filter • Ensure fuel shut off valve is in open position
Old fuel in tank	<ul style="list-style-type: none"> • Drain tank • Refill with fresh fuel
Water, dirt, or air in fuel system	<ul style="list-style-type: none"> • Drain, flush, fill, and prime system
Improper type of fuel	<ul style="list-style-type: none"> • Use proper fuel for operating conditions
Crankcase oil too heavy	<ul style="list-style-type: none"> • Use recommended oil

ASSEMBLING THE WINDROWER

Problem	Solution
Low battery output	<ul style="list-style-type: none">• Test the battery• Check battery electrolyte level
Poor battery connection	<ul style="list-style-type: none">• Clean and tighten loose connections
Faulty starter	<ul style="list-style-type: none">• Refer to the windrower technical manual
Wiring shorted, circuit breaker open	<ul style="list-style-type: none">• Check continuity of wiring and breaker (manually reset)
Faulty injectors	<ul style="list-style-type: none">• Refer to the windrower technical manual

3.7 Installing AM/FM Radio

M155E4 Windrowers are designed to accept a DIN E style AM/FM radio with a depth (X) of 161 mm and having a 5 mm threaded stud (A) centered on the rear for support. Adjustments are possible if the radio falls outside these parameters.

In order to retain radio settings and preset memory with the battery disconnect turned off, select a radio with non-volatile settings memory.

NOTE:

An approved radio package is available from Radio Engineering Industries (REI) of Omaha, Nebraska.

1. Ensure the ignition is turned to the OFF position.
2. Remove radio panel by removing four screws (A).

3. Remove screw and nuts (A) and (C) to remove support (B) from panel. Retain nut (C) and lock washer.

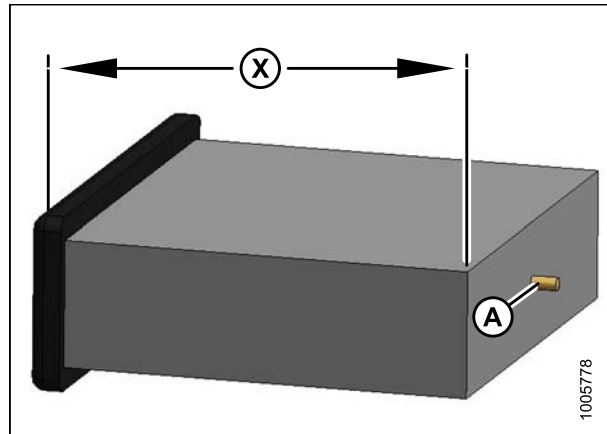

Figure 3.18: Mounting Dimension

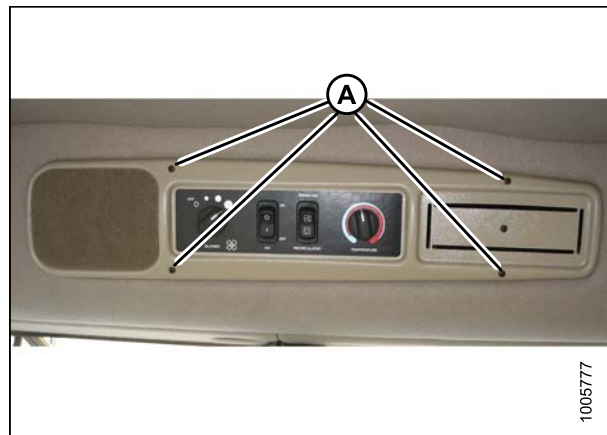

Figure 3.19: Radio Panel

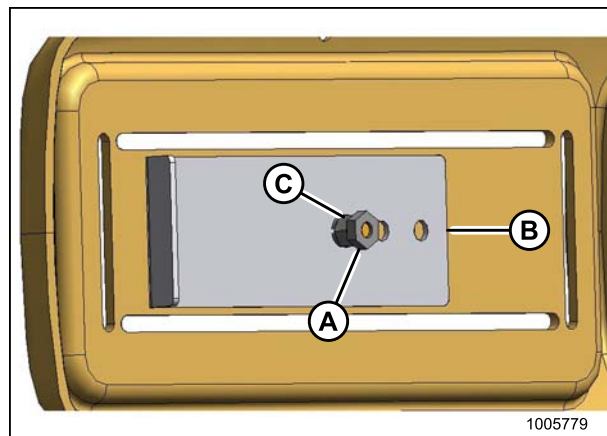

Figure 3.20: Panel Support

ASSEMBLING THE WINDROWER

4. Remove the cutout by cutting the tabs (A) in the panel. Remove sharp edges from the panel.

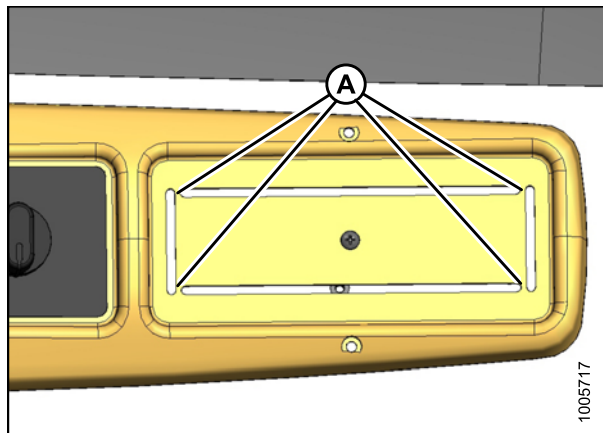

Figure 3.21: Panel

5. Position receptacle (A) (supplied with radio) into opening and secure by bending tabs (B) on receptacle against panel.

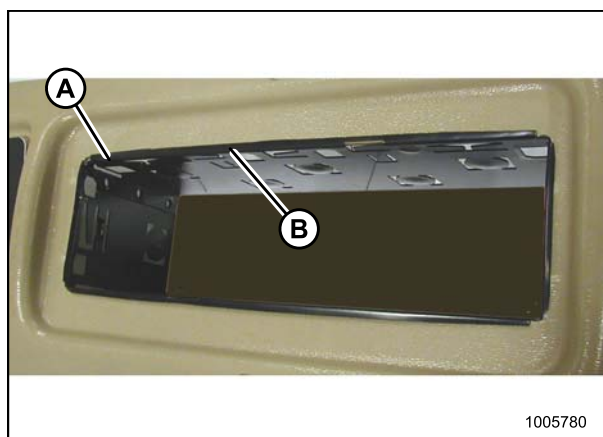

Figure 3.22: Radio Receptacle

6. Insert radio into receptacle and attach radio bezel. Ensure radio locks into position and faceplate (A) is against the panel.



Figure 3.23: Radio Installed

ASSEMBLING THE WINDROWER

7. Ensure the radio has a six-pin connector (Packard #2977042) and a terminal arrangement as shown at right. This enables the radio to connect to the windrower's six-pin radio connector wiring harness.
8. Attach the following two additional wires from the wiring harness to the radio:
 - a. **Circuit 503:** Red live-wire with 1/4 in. female blade terminal provides power for the radio clock/memory if radio is equipped with this feature.
 - b. **Circuit 315:** Black ground-wire attaches to the radio body.
9. Plug antenna cable into radio.

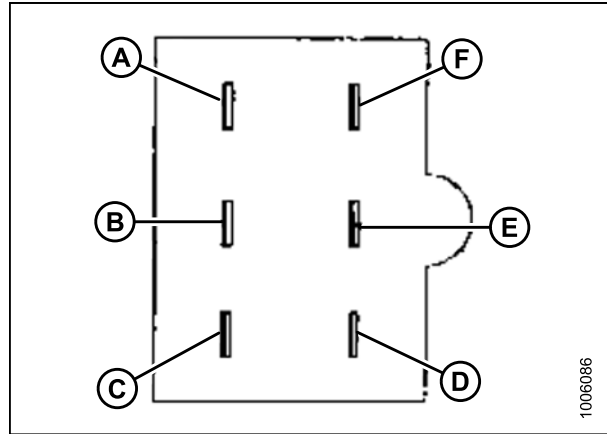

Figure 3.24: Six-Pin Connector Terminal Arrangement

- A - Left Speaker Power (+)
- B - Left Speaker Ground (-)
- C - Radio Ground (-)
- D - Right Speaker Ground (-)
- E - Right Speaker Power (+)
- F - Radio Power (+) (Live when Ignition is ON)

10. Attach stud (supplied with radio) to center rear of radio.
11. Attach support (B) to stud on back of radio chassis with nut (A) and lock washer supplied with the support.

NOTE:

Support can be attached to chassis in multiple locations to allow for proper radio mounting.

12. Install radio panel using original screws.

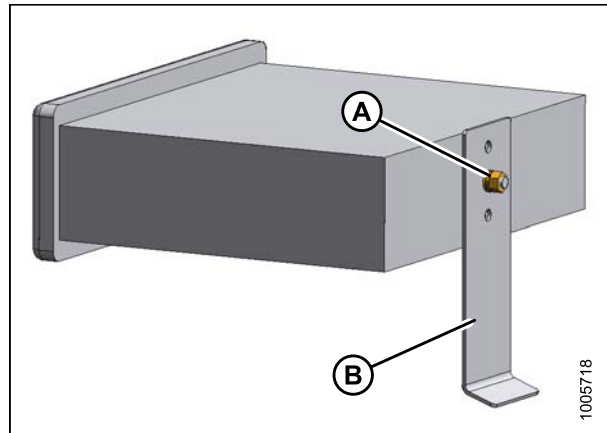

Figure 3.25: Radio and Support

13. Adjust bracket (A) (if necessary) by loosening nuts (B) to allow radio to slide into opening and securely capture support (C).
14. Retrieve antenna from inside cab and remove protective cover from base.

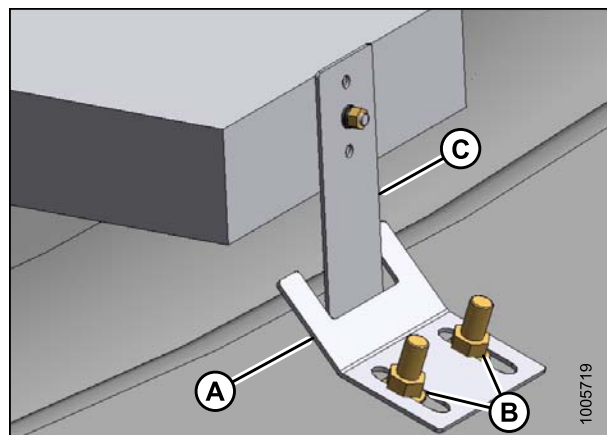

Figure 3.26: Radio and Support

ASSEMBLING THE WINDROWER

15. Remove protective cover (A) from antenna mount on cab roof and thread antenna onto base until hand tight.

NOTE:

Store protective cover in cab and reinstall to protect antenna mount if antenna needs to be removed.

16. Turn the ignition key to ACC, switch radio ON, and check operation in accordance with instructions supplied with the radio.
17. Turn the ignition key to the OFF position.

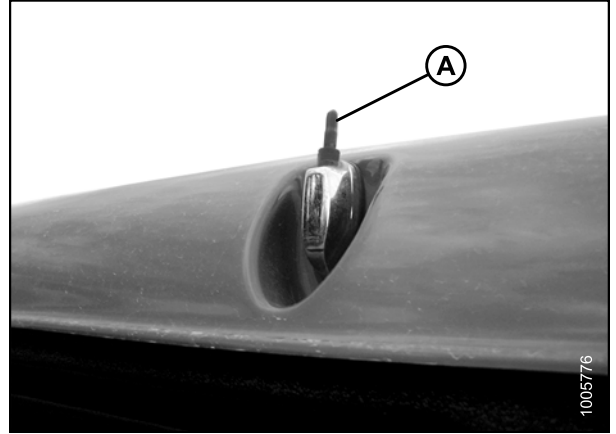

Figure 3.27: Antenna Mount on Cab Roof

3.8 Installing the Slow Moving Vehicle (SMV) Sign

1. Install the SMV sign (A) (shipped inside the cab) onto the windrower in accordance with the instructions supplied with the sign. SMV signs must be visible when travelling on the road.

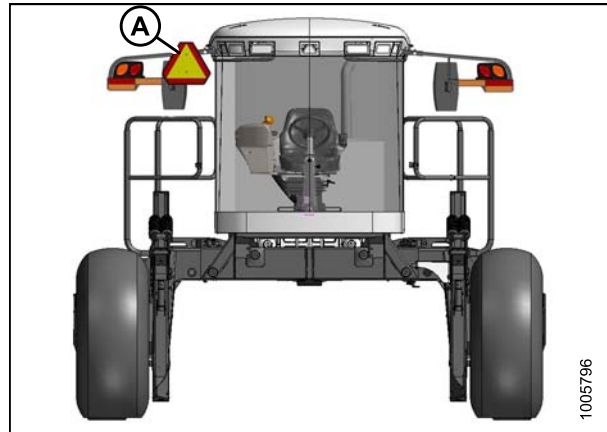

Figure 3.28: Engine-Forward Location

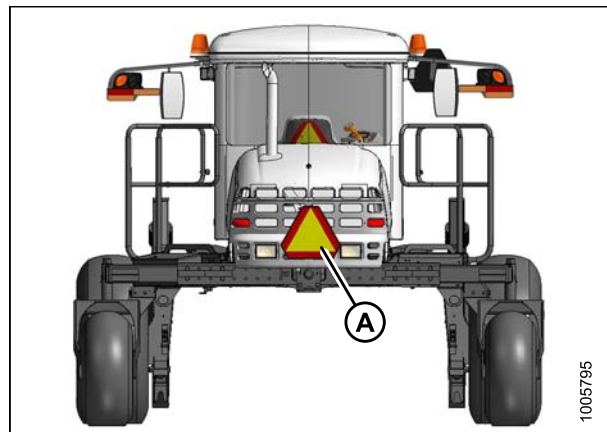

Figure 3.29: Cab-Forward Location

3.9 Attaching Headers

3.9.1 Attaching Header Boots

Header boots are required to attach a D-Series draper header to the windrower. Attach header boots (supplied with header) to windrower lift linkage if not already installed.

CAUTION

To prevent damage to the lift system when lowering header lift linkages without a header or weight box attached to the windrower, ensure the float engagement pin is installed in storage position (B) and NOT in engaged position (A).

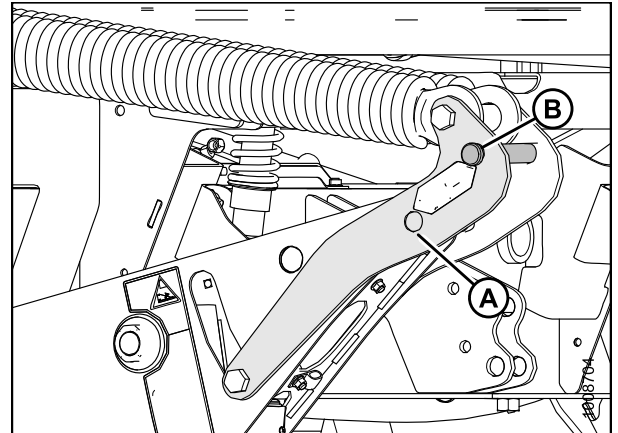

Figure 3.30: Header Float Linkage

1. Remove pin (B) from boot (A).

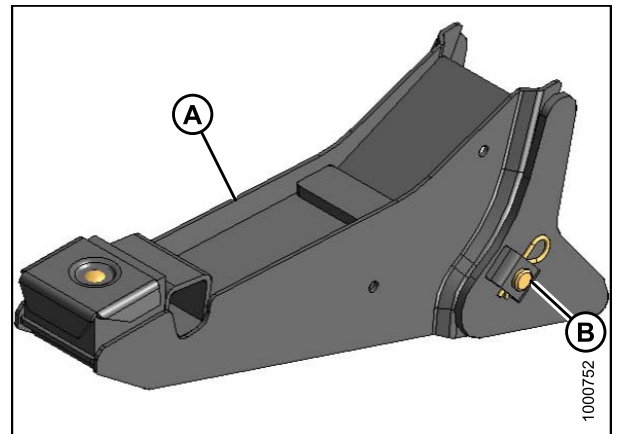

Figure 3.31: Header Boot

2. Position boot (B) onto lift linkage (A) and reinstall pin (C). Pin may be installed from either side of boot.
3. Secure pin (C) with hairpin (D).
4. Repeat for opposite side.

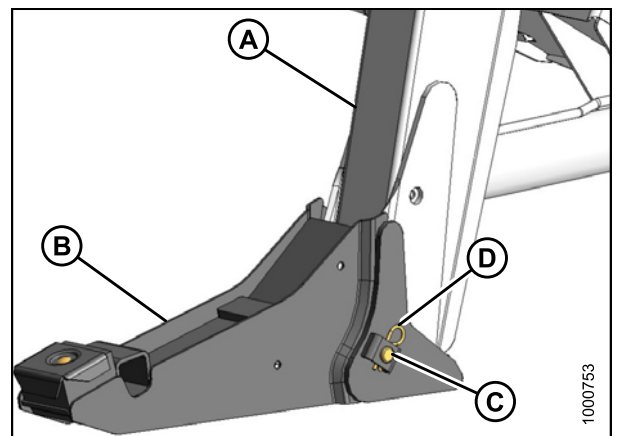

Figure 3.32: Header Boot

3.9.2 Attaching a D-Series Header

D50, D60, and D65 headers can be attached to an M155E4 Self-Propelled Windrower.

The M155E4 Self-Propelled Windrower is factory-equipped to run a D-Series Draper Header.

If installing an HC10 Hay Conditioner, reverser kit MD #B4656 is recommended. If necessary, obtain the recommended kit and install it in accordance with the instructions supplied with the kit.

Refer to the following instructions based on the type of center-link installed on your windrower:

- [Attaching a D-Series Header: Hydraulic Center-Link with Optional Self-Alignment, page 28](#)
- [Attaching a D-Series Header: Hydraulic Center-Link without Self-Alignment, page 33](#)

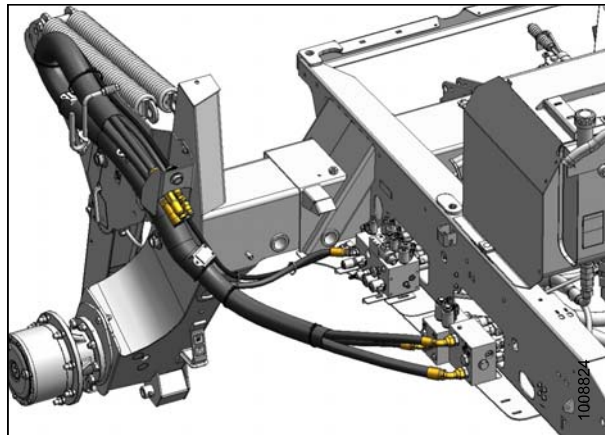

Figure 3.33: M155E4 Draper Header Hydraulics

Attaching a D-Series Header: Hydraulic Center-Link with Optional Self-Alignment

NOTE:

Draper header boots must be installed onto the windrower lift linkage before starting this procedure. Refer to [3.9.1 Attaching Header Boots, page 27](#).

⚠ DANGER

To avoid bodily injury or death from unexpected startup of the machine, always stop the engine and remove the key from the ignition before leaving the operator's seat for any reason.

1. Remove hairpin (A) from pins (B), and remove pins from both header legs.

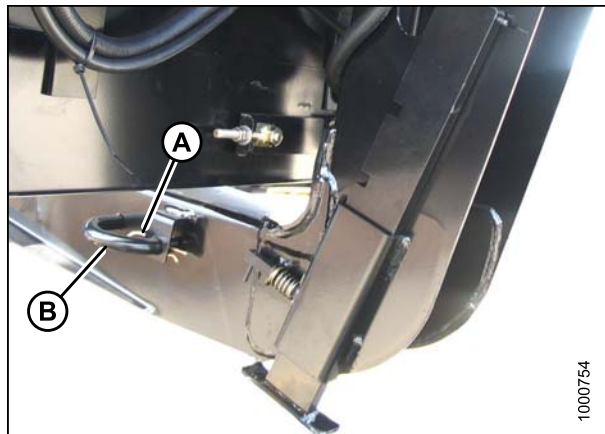

Figure 3.34: Header Leg

ASSEMBLING THE WINDROWER

CAUTION

Check to be sure all bystanders have cleared the area.

IMPORTANT:

Remove protective cover from exhaust stack prior to starting engine.

2. Start the engine and activate the HEADER DOWN button (A) on the ground speed lever (GSL) to fully retract header lift cylinders.

3. Activate the REEL UP switch (A) on the GSL to raise the center-link until the hook is above the attachment pin on the header.

IMPORTANT:

If the center-link is too low, it may contact the header as the windrower approaches the header for hookup.

4. Drive the windrower slowly forward until the boots (A) enter the header legs (B). Continue driving slowly forward until lift linkages contact the support plates in the header legs and the header nudges forward.
5. Ensure the lift linkages are properly engaged in the header legs and are contacting the support plates.

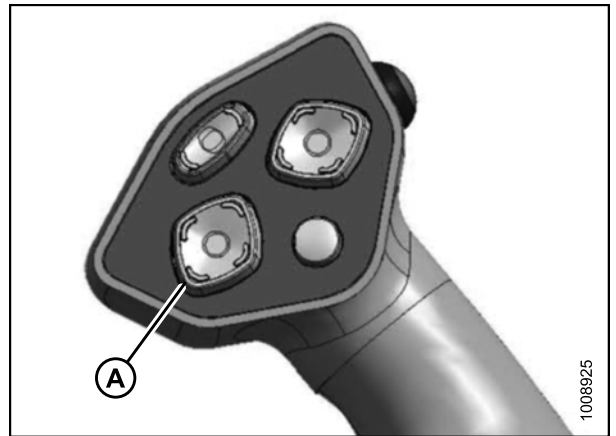

Figure 3.35: Ground Speed Lever

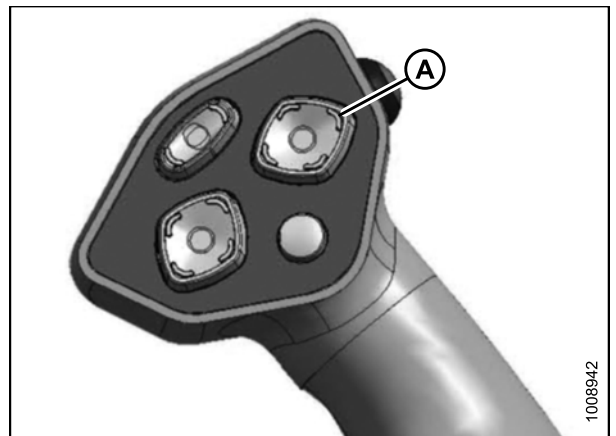

Figure 3.36: Ground Speed Lever

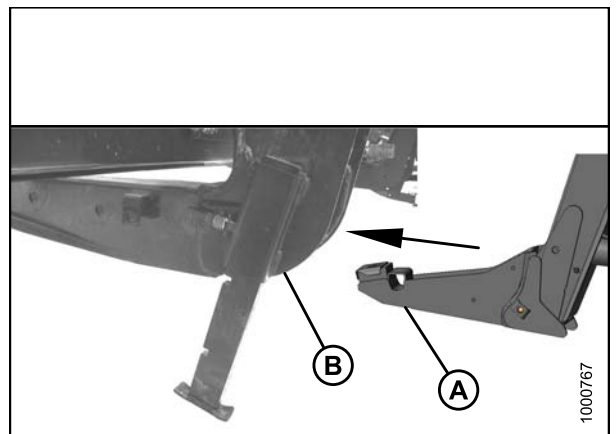

Figure 3.37: Header Leg and Boot

ASSEMBLING THE WINDROWER

6. Use the following GSL functions to position the center-link hook above the header attachment pin:
- Reel up (A) to raise the center-link
 - Reel down (B) to lower the center-link
 - Header tilt up (C) to retract the center-link
 - Header tilt down (D) to extend the center-link

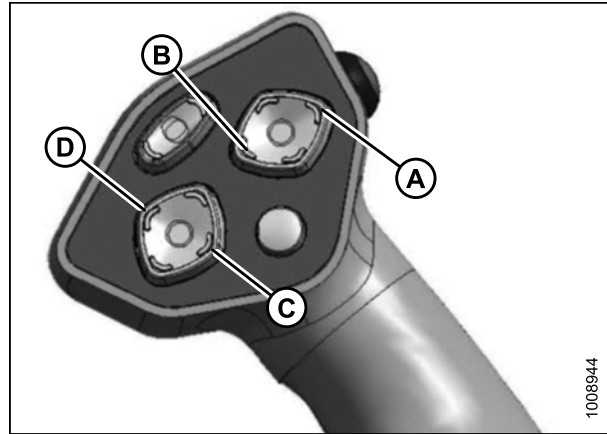

Figure 3.38: Ground Speed Lever

7. Adjust position of the center-link cylinder (A) with the REEL UP, REEL DOWN, AND HEADER TILT switches on the GSL until the hook is above the header attachment pin.

IMPORTANT:

Hook release must be down to enable self-locking mechanism. If the release is open (up), manually push it down after hook engages header pin.

8. Lower center-link (A) onto the header with the REEL DOWN switch on the GSL until it locks into position (hook release [B] is down).
9. Check that center-link is locked onto header by pressing the REEL UP switch on the GSL.

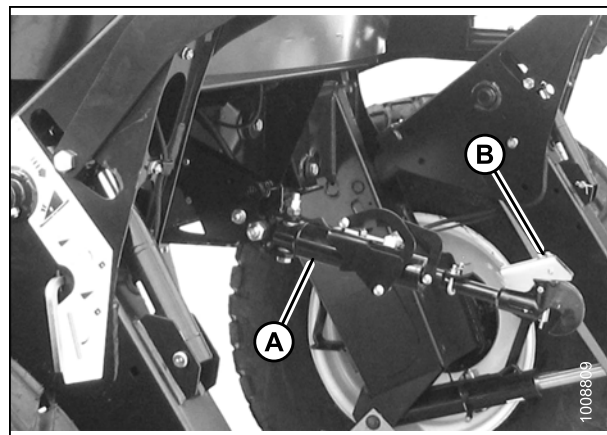

Figure 3.39: Hydraulic Center-Link

CAUTION

Check to be sure all bystanders have cleared the area.

10. Press the HEADER UP switch (A) to raise header to maximum height.

NOTE:

If one end of the header does **NOT** fully rise, rephase the lift cylinders as follows:

- Press and hold the HEADER UP switch until both cylinders stop moving.
- Continue to hold the switch for 3–4 seconds. Cylinders are now phased.

NOTE:

It may be necessary to repeat this procedure if there is air in the system.

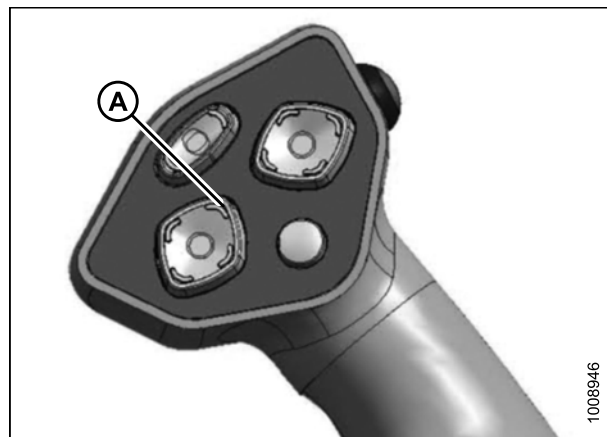

Figure 3.40: Ground Speed Lever

ASSEMBLING THE WINDROWER

11. Engage safety props on both lift cylinders as follows:
 - a. Stop engine and remove key from ignition.
 - b. Pull lever (A) and rotate towards the header to release and lower safety prop (B) onto the lift cylinder.
 - c. Repeat for opposite lift cylinder.

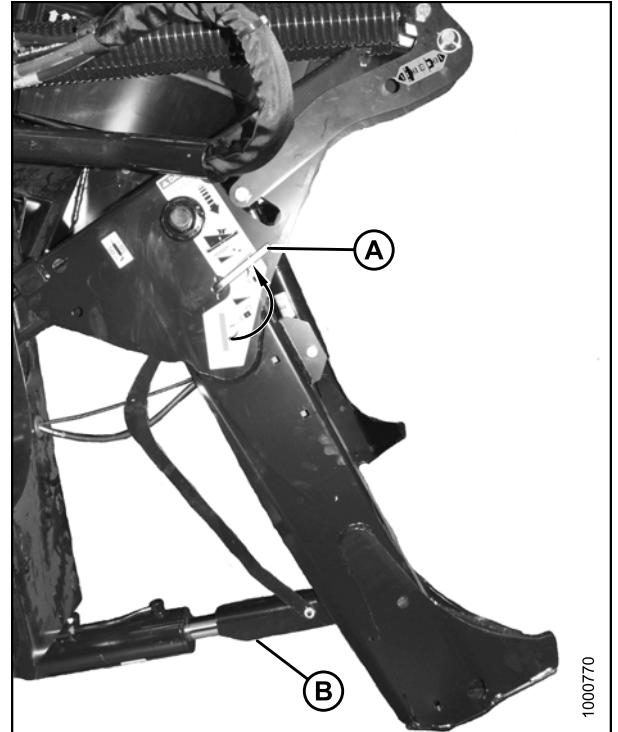

Figure 3.41: Safety Prop

12. Install pin (B) through the header leg (engaging U-bracket in lift linkage) on both sides and secure with hairpin (A).
13. Raise header stand (D) to storage position by pulling spring pin (C) and lifting stand into uppermost position. Release spring pin.

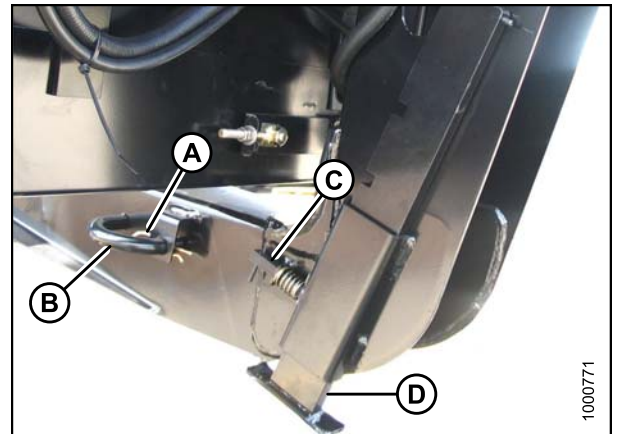

Figure 3.42: Header Leg

ASSEMBLING THE WINDROWER

14. Remove clevis pin from storage position (B) in linkage and insert into hole (A) to engage float springs. Secure with hairpin.

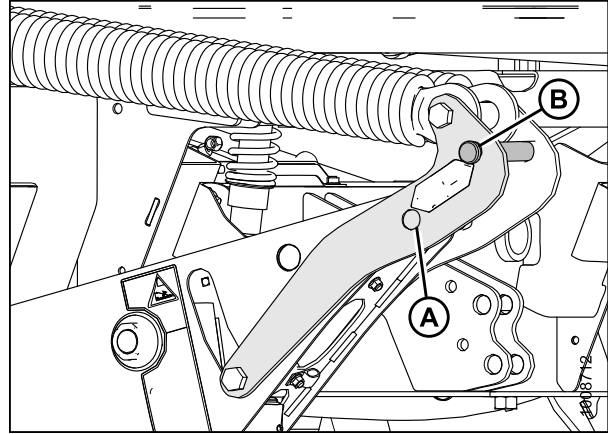

Figure 3.43: Header Float Linkage

15. Disengage safety prop by turning lever (A) downwards to release and lower stop until lever locks into vertical position.
16. Repeat for opposite safety prop.

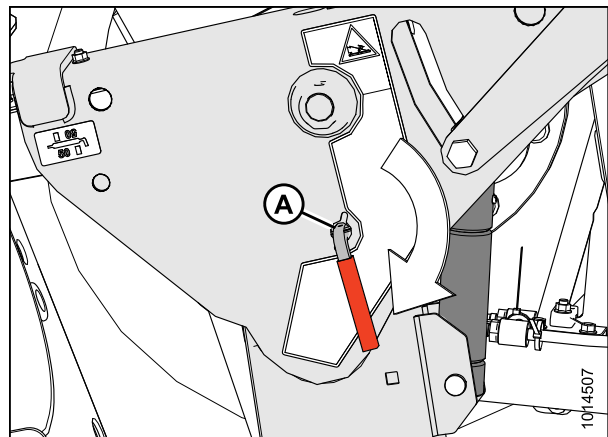

Figure 3.44: Safety Prop

CAUTION

Check to be sure all bystanders have cleared the area.

17. Start the engine and activate the HEADER DOWN switch (A) on the GSL to fully lower the header.
18. Stop engine and remove key from ignition.

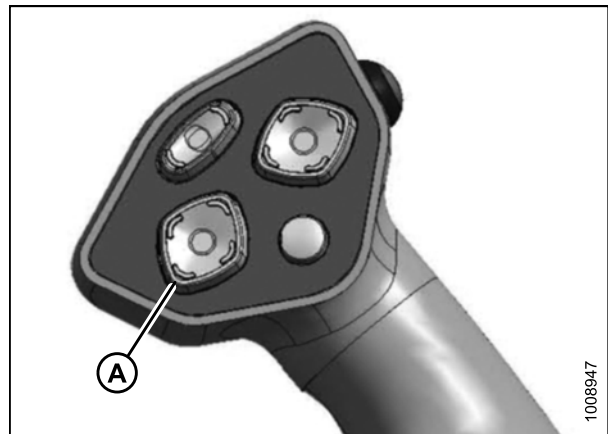

Figure 3.45: Ground Speed Lever

ASSEMBLING THE WINDROWER

19. Connect header drive hoses (A) and electrical harness (B) to header. Refer to the draper header operator's manual.

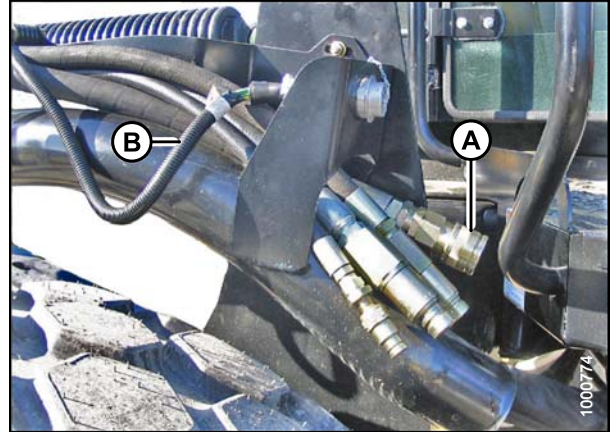

Figure 3.46: Header Drive Hoses and Harness

20. Connect reel hydraulics (A) at right cab-forward side of windrower. Refer to the draper header operator's manual.

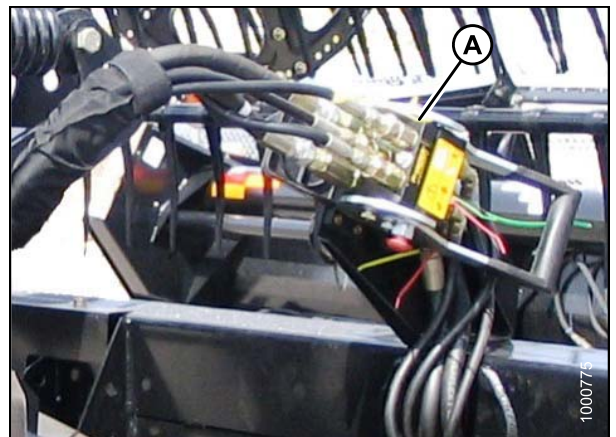

Figure 3.47: Reel Hydraulics

Attaching a D-Series Header: Hydraulic Center-Link without Self-Alignment

NOTE:

Draper header boots must be installed onto the windrower lift linkage before starting this procedure. Refer to [3.9.1 Attaching Header Boots, page 27](#).

DANGER

To avoid bodily injury or death from unexpected startup of the machine, always stop the engine and remove the key from the ignition before leaving the operator's seat for any reason.

ASSEMBLING THE WINDROWER

1. Remove hairpin (A) from pins (B), and remove pins from both header legs.

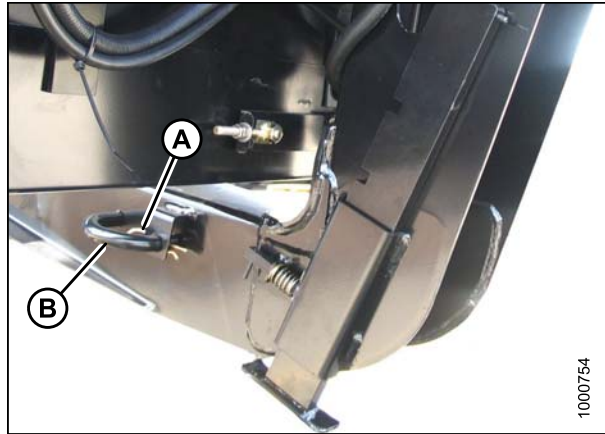

Figure 3.48: Header Leg

CAUTION

Check to be sure all bystanders have cleared the area.

IMPORTANT:

Remove protective cover from exhaust stack prior to starting engine.

2. Start the engine and activate the HEADER DOWN button (A) on the ground speed lever (GSL) to fully retract header lift cylinders.

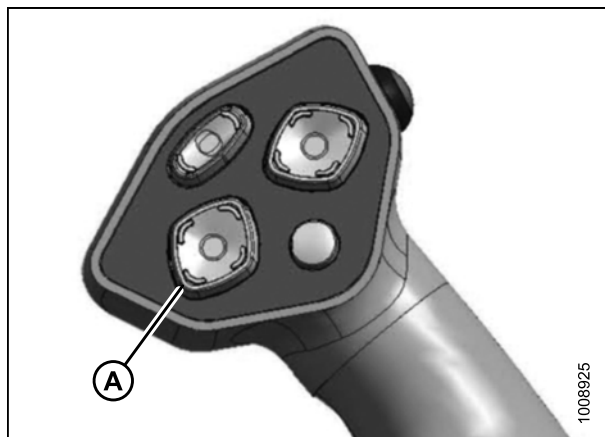

Figure 3.49: Ground Speed Lever

3. Relocate pin (A) in frame linkage as required to raise the center-link (B) until the hook is above the attachment pin on the header.

IMPORTANT:

If the center-link is too low, it may contact the header as the windrower approaches the header for hookup.

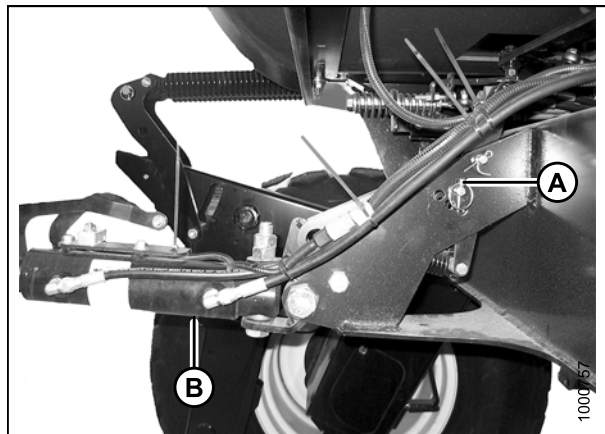

Figure 3.50: Hydraulic Center-Link without Self-Alignment Kit

ASSEMBLING THE WINDROWER

4. Drive the windrower slowly forward until the boots (A) enter the header legs (B). Continue driving slowly forward until lift linkages contact the support plates in the header legs and the header nudges forward.
5. Ensure the lift linkages are properly engaged in the header legs and are contacting the support plates.

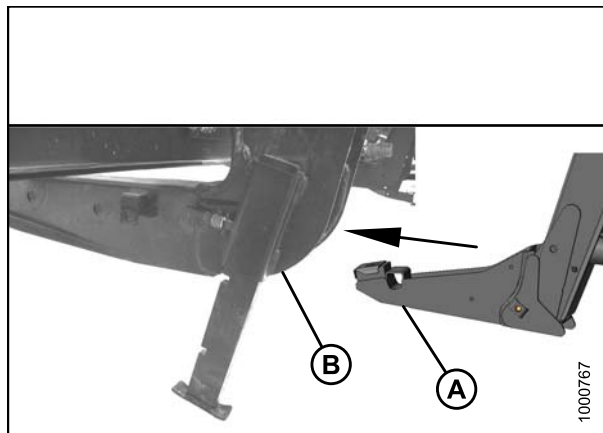

Figure 3.51: Header Leg and Boot

6. Use the following GSL functions to position the center-link hook above the header attachment pin:
 - Header tilt up (A) to retract the center-link
 - Header tilt down (B) to extend the center-link
7. Stop engine and remove key from ignition.

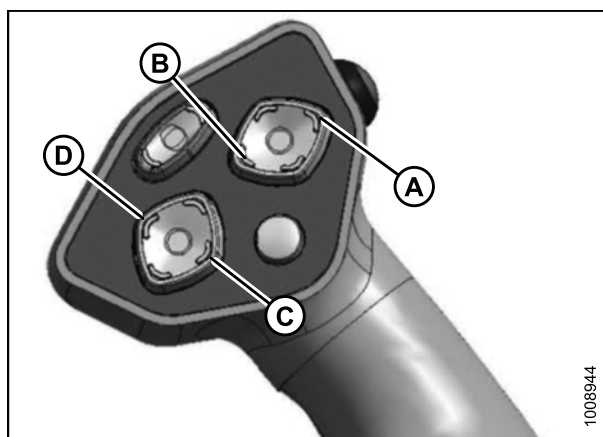

Figure 3.52: Ground Speed Lever

8. Push down on rod end of link cylinder (B) until hook engages and locks onto header pin.

IMPORTANT:

Hook release must be down to enable self-locking mechanism. If the release is open (up), manually push it down after hook engages header pin.

9. Check that center-link (A) is locked onto header by pulling upward on rod end (B) of cylinder.

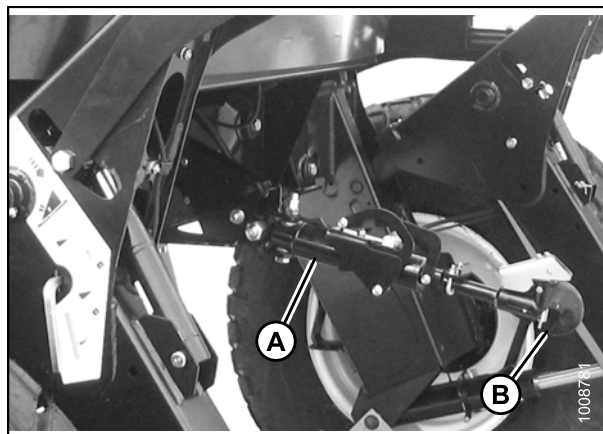

Figure 3.53: Hydraulic Center-Link

ASSEMBLING THE WINDROWER

CAUTION

Check to be sure all bystanders have cleared the area.

10. Start the engine.
11. Press the HEADER UP switch (A) to raise header to maximum height.

NOTE:

If one end of the header does **NOT** fully rise, rephase the lift cylinders as follows:

- a. Press and hold the HEADER UP switch until both cylinders stop moving.
- b. Continue to hold the switch for 3–4 seconds. Cylinders are now phased.

NOTE:

It may be necessary to repeat this procedure if there is air in the system.

12. Engage safety props on both lift cylinders as follows:
 - a. Stop engine and remove key from ignition.
 - b. Pull lever (A) and rotate towards the header to release and lower safety prop (B) onto the lift cylinder.
 - c. Repeat for opposite lift cylinder.

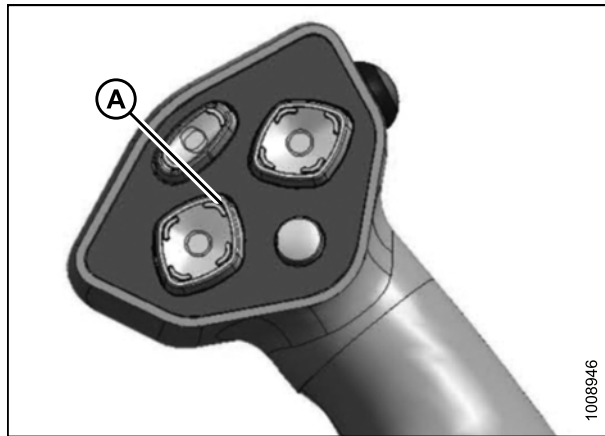

Figure 3.54: Ground Speed Lever

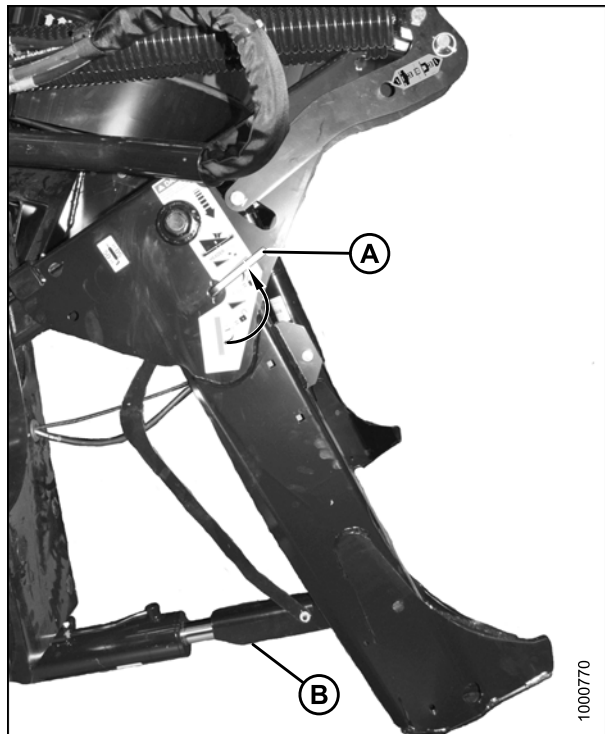

Figure 3.55: Safety Prop

ASSEMBLING THE WINDROWER

13. Install pin (B) through the header leg (engaging U-bracket in lift linkage) on both sides and secure with hairpin (A).
14. Raise header stand (D) to storage position by pulling spring pin (C) and lifting stand into uppermost position. Release spring pin.

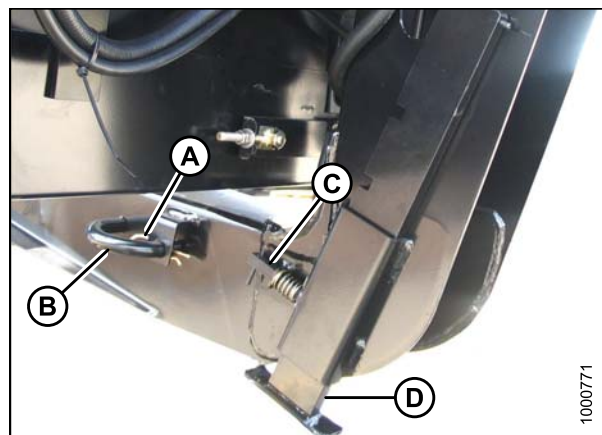

Figure 3.56: Header Leg

15. Remove clevis pin from storage position (B) in linkage and insert into hole (A) to engage float springs. Secure with hairpin.

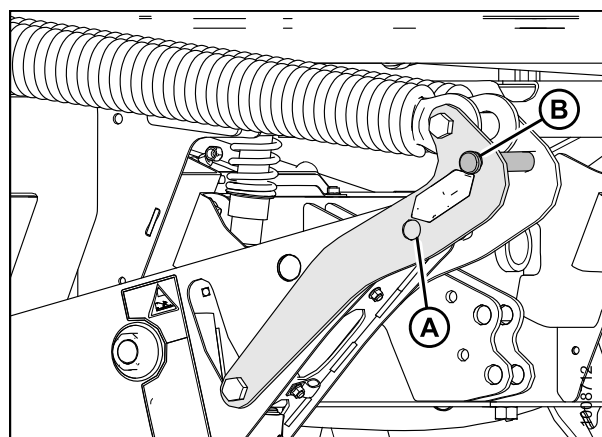

Figure 3.57: Header Float Linkage

16. Disengage safety prop by turning lever (A) downwards to release and lower stop until lever locks into vertical position.
17. Repeat for opposite safety prop.

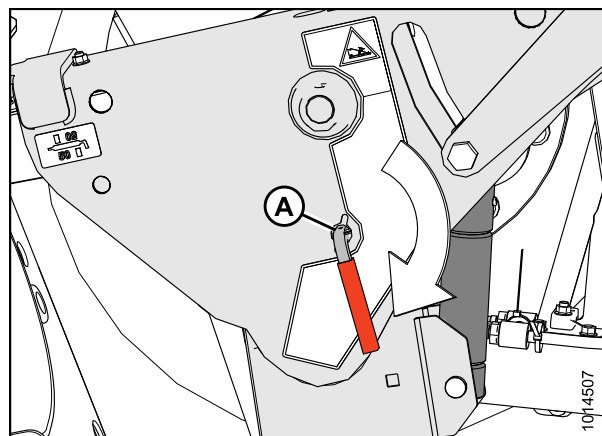

Figure 3.58: Safety Prop

ASSEMBLING THE WINDROWER

CAUTION

Check to be sure all bystanders have cleared the area.

18. Start the engine and activate the HEADER DOWN switch (A) on the GSL to fully lower the header.
19. Stop engine and remove key from ignition.

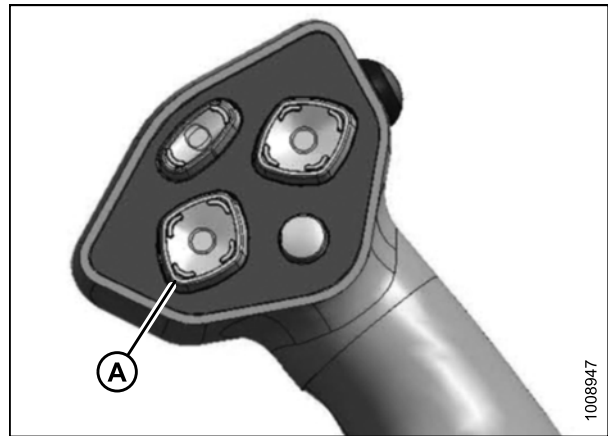

Figure 3.59: Ground Speed Lever

20. Connect header drive hoses (A) and electrical harness (B) to header. Refer to the draper header operator's manual.

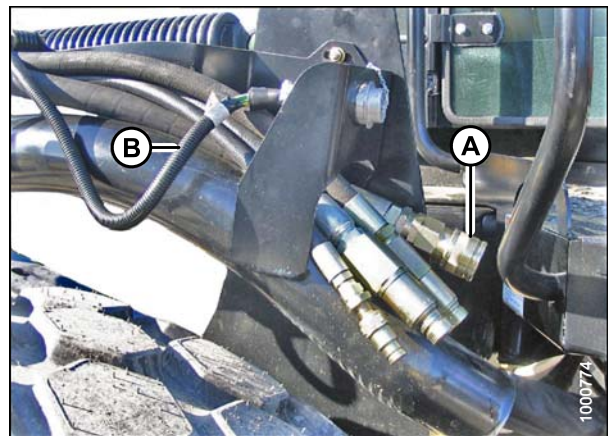

Figure 3.60: Header Drive Hoses and Harness

21. Connect reel hydraulics (A) at right cab-forward side of windrower. Refer to the draper header operator's manual.

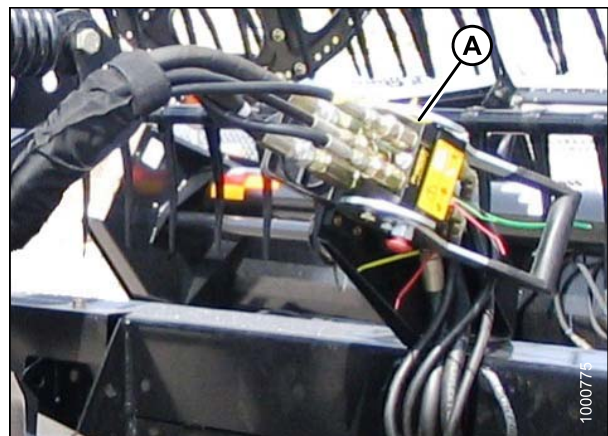

Figure 3.61: Reel Hydraulics

3.9.3 Attaching an A-Series Header

A30-D, A30-S, and A40-D headers can be attached to an M155E4 Self-Propelled Windrower.

The M155E4 Self-Propelled Windrower is factory-equipped to run an A-Series Auger Header.

Windrowers equipped with A-Series hydraulics have four header-drive hoses on the left-hand side.

The attachment procedure varies depending on the type of center-link installed on the windrower. Refer to the following instructions based on the type of center-link installed on your windrower:

- [Attaching an A-Series Header: Hydraulic Center-Link with Optional Self-Alignment, page 40](#)
- [Attaching an A-Series Header: Hydraulic Center-Link without Self-Alignment, page 45](#)



Figure 3.62: M155E4 and A40-D Auger Header

ASSEMBLING THE WINDROWER

Attaching an A-Series Header: Hydraulic Center-Link with Optional Self-Alignment

DANGER

To avoid bodily injury or death from unexpected startup of the machine, always stop the engine and remove the key from the ignition before leaving the operator's seat for any reason.

1. Remove hairpin (A) from clevis pin (B) and remove clevis pin from the header boots (C) on both sides of the header.

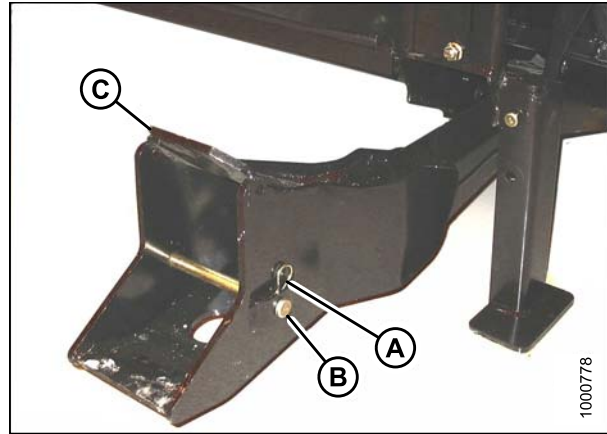

Figure 3.63: Header Boot

CAUTION

To prevent damage to the lift system when lowering header lift linkages without a header or weight box attached to the windrower, ensure the float engagement pin is installed in storage position (B) and NOT in engaged position (A).

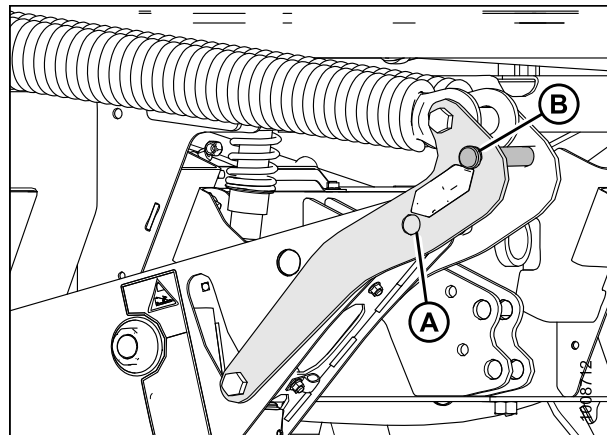

Figure 3.64: Header Float Linkage

CAUTION

Check to be sure all bystanders have cleared the area.

IMPORTANT:

Remove protective cover from exhaust stack prior to starting engine.

2. Start the engine and activate the HEADER DOWN button (A) on the ground speed lever (GSL) to fully retract header lift cylinders.

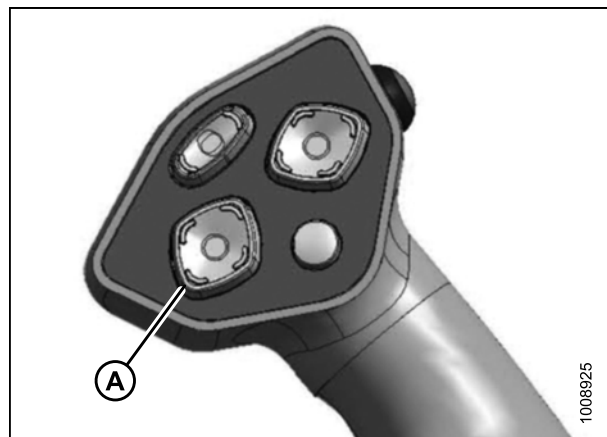

Figure 3.65: Ground Speed Lever

ASSEMBLING THE WINDROWER

3. Activate the REEL UP switch (A) on the GSL to raise the center-link until the hook is above the attachment pin on the header.

IMPORTANT:

If the center-link is too low, it may contact the header as the windrower approaches the header for hookup.

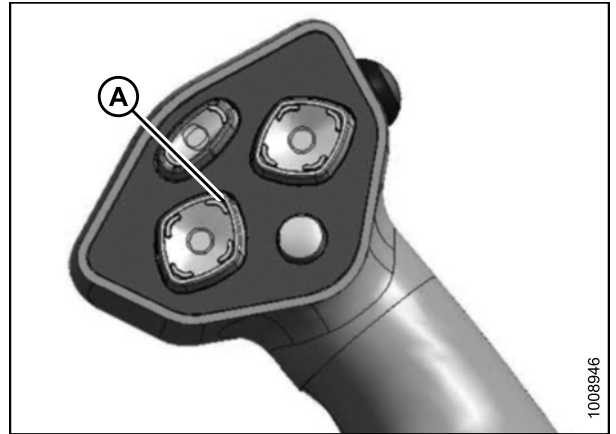

Figure 3.66: Ground Speed Lever

4. Drive the windrower slowly forward until the windrower feet (A) enter the header boots (B). Continue driving slowly forward until the feet engage the boots and the header nudges forward.

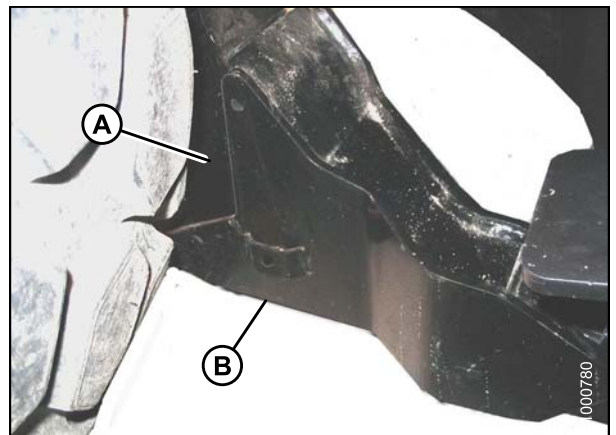

Figure 3.67: Header Boot

5. Use the following GSL functions to position the center-link hook above the header attachment pin:
 - Reel up (A) to raise the center-link
 - Reel down (B) to lower the center-link
 - Header tilt up (C) to retract the center-link
 - Header tilt down (D) to extend the center-link

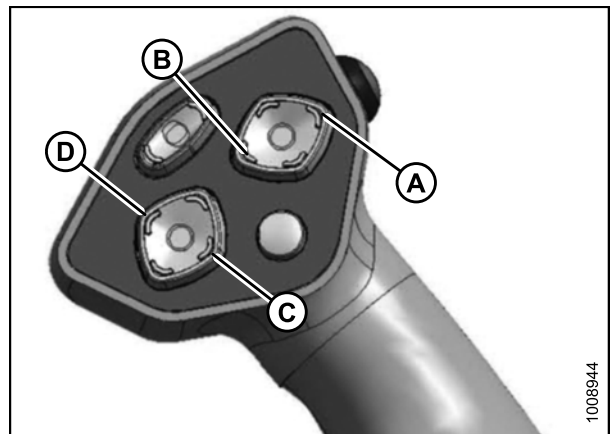

Figure 3.68: Ground Speed Lever

ASSEMBLING THE WINDROWER

- Adjust position of the center-link cylinder (A) with the REEL UP and REEL DOWN switches on the GSL until the hook is positioned above the header attachment pin.

IMPORTANT:

Hook release must be down to enable self-locking mechanism. If the release is open (up), manually push it down after hook engages header pin.

- Lower center-link (A) onto the header with REEL DOWN switch until it locks into position (hook release [B] is down).
- Check that center-link is locked onto header by pressing the REEL UP switch on the GSL.

CAUTION

Check to be sure all bystanders have cleared the area.

- Press the HEADER UP switch (A) to raise header to maximum height.

NOTE:

If one end of the header does **NOT** fully rise, rephase the lift cylinders as follows:

- Press and hold the HEADER UP switch until both cylinders stop moving.
- Continue to hold the switch for 3–4 seconds. Cylinders are now phased.

NOTE:

It may be necessary to repeat this procedure if there is air in the system.

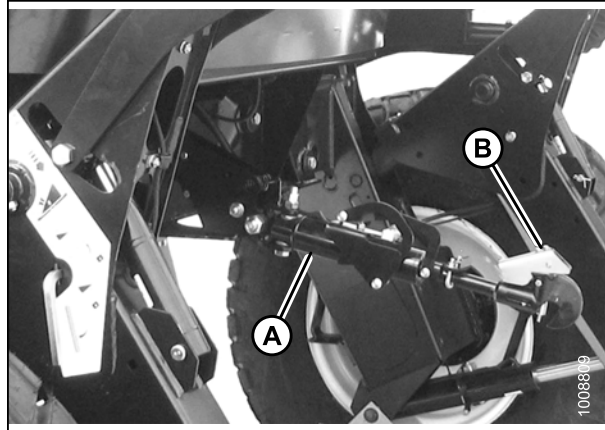

Figure 3.69: Hydraulic Center-Link



Figure 3.70: Ground Speed Lever

ASSEMBLING THE WINDROWER

10. Engage safety props on both lift cylinders as follows:
 - a. Stop engine and remove key from ignition.
 - b. Pull lever (A) and rotate towards the header to release and lower safety prop (B) onto the lift cylinder.
 - c. Repeat for opposite lift cylinder.

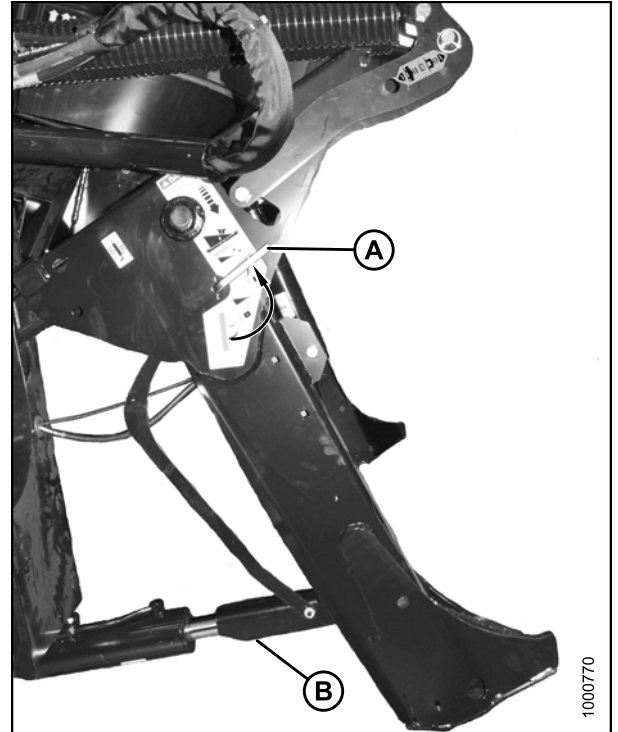

Figure 3.71: Safety Prop

11. Install clevis pin (A) through boot and foot and secure with hairpin. Repeat for opposite boot.

IMPORTANT:

Ensure clevis pin (A) is fully inserted and hairpin is installed behind bracket.

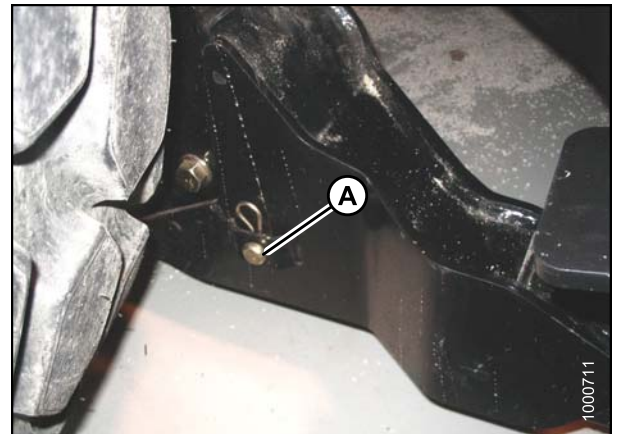

Figure 3.72: Header Boot

ASSEMBLING THE WINDROWER

12. Remove lynch pin from clevis pin (A) in stand (B).
13. Hold stand (B) and remove pin (A).
14. Move stand (B) to storage position by inverting and relocating onto bracket as shown. Reinsert clevis pin (A) and secure with lynch pin.

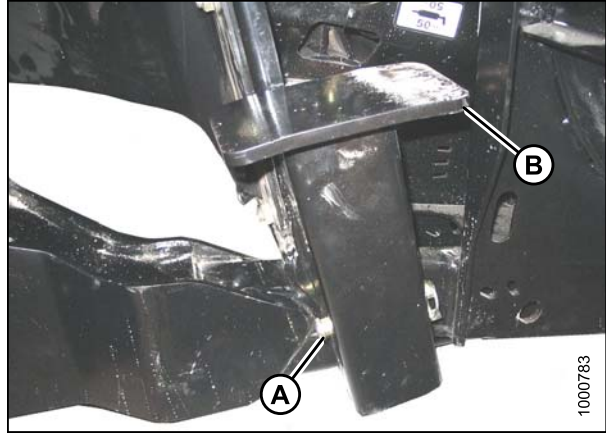

Figure 3.73: Header Stand

15. Remove clevis pin from storage position (B) in linkage and insert into hole (A) to engage float springs. Secure with hairpin.

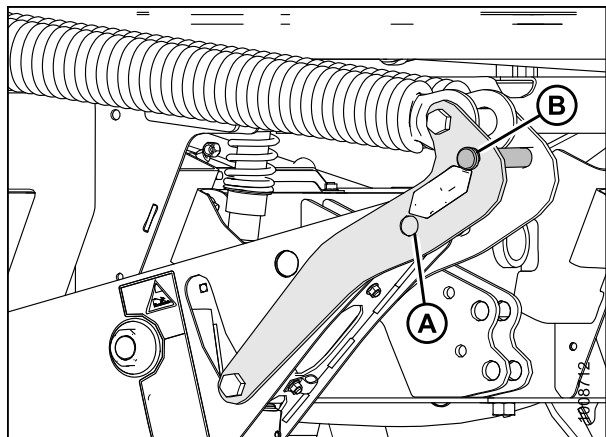

Figure 3.74: Header Float Linkage

16. Disengage safety prop by turning lever (A) downwards to release and lower stop until lever locks into vertical position.
17. Repeat for opposite safety prop.

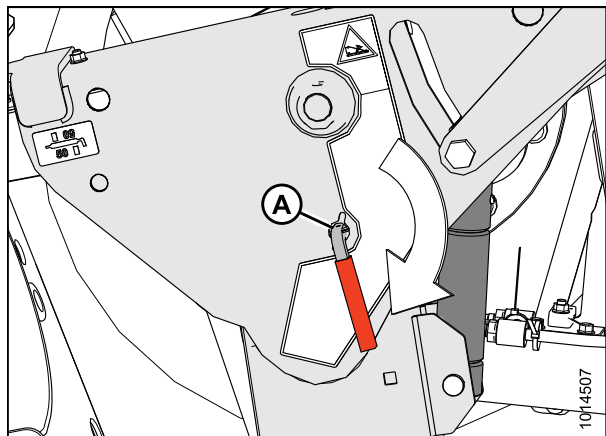

Figure 3.75: Safety Prop

ASSEMBLING THE WINDROWER

CAUTION

Check to be sure all bystanders have cleared the area.

18. Start the engine and activate the HEADER DOWN switch (A) on the GSL to fully lower the header.
19. Stop engine and remove key from ignition.

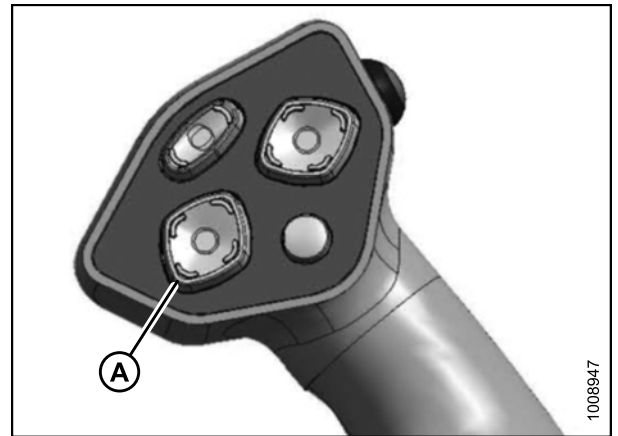

Figure 3.76: Ground Speed Lever

20. Connect header drive hoses (A) and electrical harness (B) to header. Refer to the auger header operator's manual.

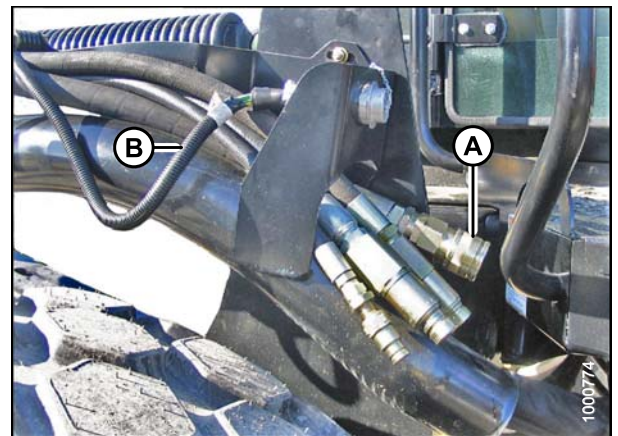

Figure 3.77: Header Drive Hoses and Harness

Attaching an A-Series Header: Hydraulic Center-Link without Self-Alignment

DANGER

To avoid bodily injury or death from unexpected startup of the machine, always stop the engine and remove the key from the ignition before leaving the operator's seat for any reason.

1. Remove hairpin (A) from clevis pin (B) and remove clevis pin from the header boots (C) on both sides of the header.

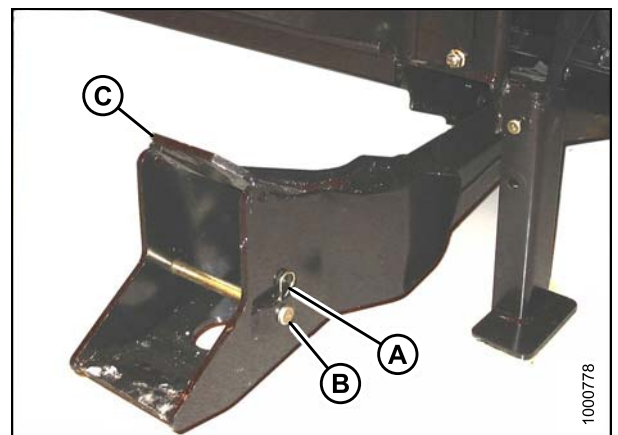

Figure 3.78: Header Boot

ASSEMBLING THE WINDROWER

CAUTION

To prevent damage to the lift system when lowering header lift linkages without a header or weight box attached to the windrower, ensure the float engagement pin is installed in storage position (B) and NOT in engaged position (A).

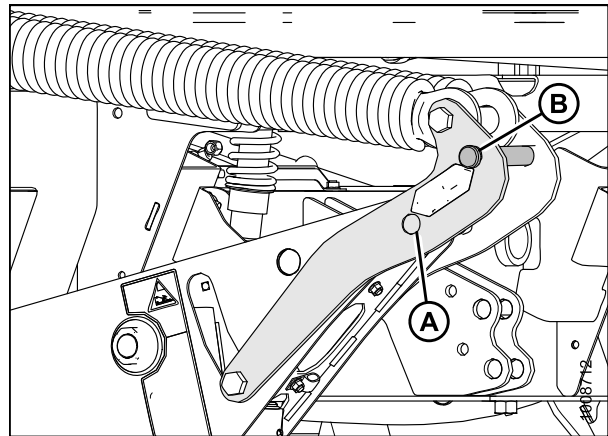

Figure 3.79: Header Float Linkage

CAUTION

Check to be sure all bystanders have cleared the area.

IMPORTANT:

Remove protective cover from exhaust stack prior to starting engine.

2. Start the engine and activate the HEADER DOWN button (A) on the ground speed lever (GSL) to fully retract header lift cylinders.
3. Relocate pin (A) in frame linkage as required to raise the center-link (B) until the hook is above the attachment pin on the header.

IMPORTANT:

If the center-link is too low, it may contact the header as the windrower approaches the header for hookup.

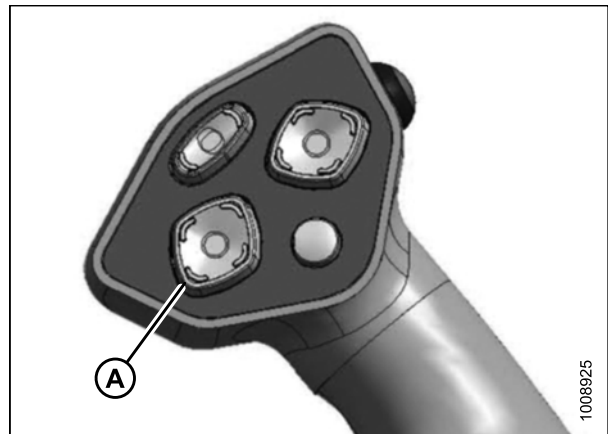

Figure 3.80: Ground Speed Lever

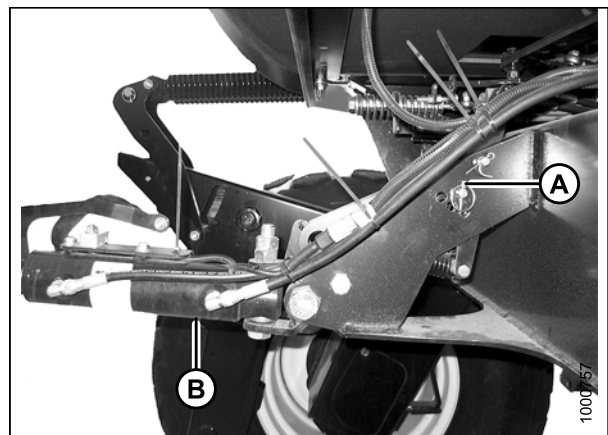

Figure 3.81: Hydraulic Center-Link without Self-Alignment Kit

ASSEMBLING THE WINDROWER

4. Drive the windrower slowly forward until the windrower feet (A) enter the header boots (B). Continue driving slowly forward until the feet engage the boots and the header nudges forward.

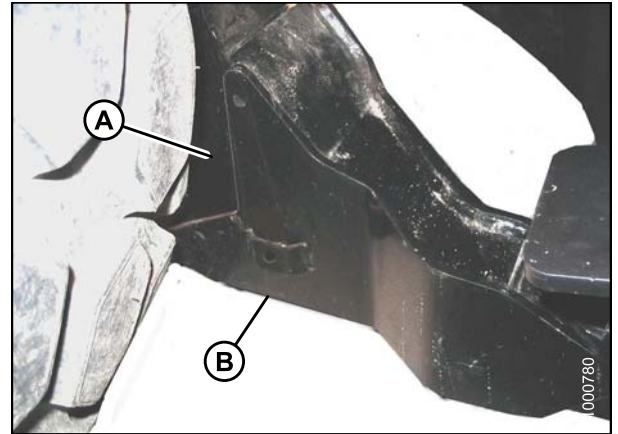

Figure 3.82: Header Boot

5. Use the following GSL functions to position the center-link hook above the header attachment pin:
 - Header tilt up (A) to retract center-link
 - Header tilt down (B) to extend center-link
6. Stop engine and remove key from ignition.

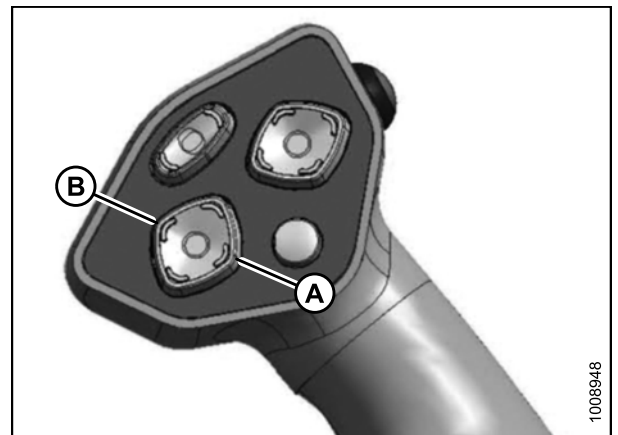

Figure 3.83: Ground Speed Lever

7. Push down on rod end of link cylinder (B) until hook engages and locks onto header pin.

IMPORTANT:

Hook release must be down to enable self-locking mechanism. If the release is open (up), manually push it down after hook engages header pin.

8. Check that center-link (A) is locked onto header by pulling upward on rod end (B) of cylinder.

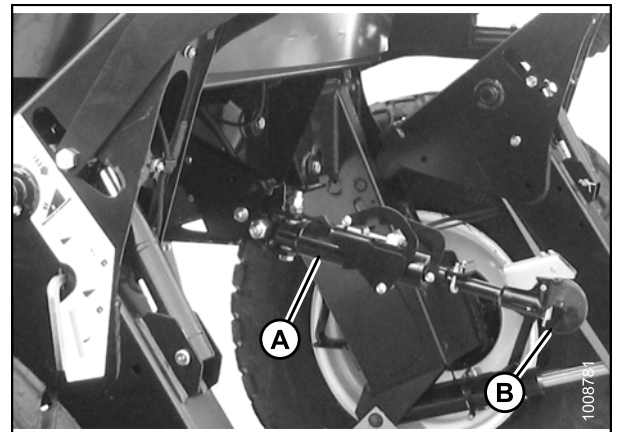

Figure 3.84: Hydraulic Center-Link

ASSEMBLING THE WINDROWER

CAUTION

Check to be sure all bystanders have cleared the area.

9. Start the engine.
10. Press the HEADER UP switch (A) to raise header to maximum height.

NOTE:

If one end of the header does **NOT** fully rise, rephase the lift cylinders as follows:

- a. Press and hold the HEADER UP switch until both cylinders stop moving.
- b. Continue to hold the switch for 3–4 seconds. Cylinders are now phased.

NOTE:

It may be necessary to repeat this procedure if there is air in the system.

11. Engage safety props on both lift cylinders as follows:
 - a. Stop engine and remove key from ignition.
 - b. Pull lever (A) and rotate towards the header to release and lower safety prop (B) onto the lift cylinder.
 - c. Repeat for opposite lift cylinder.

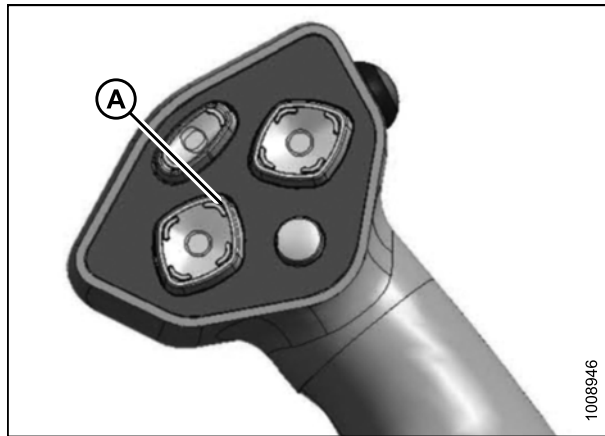

Figure 3.85: Ground Speed Lever

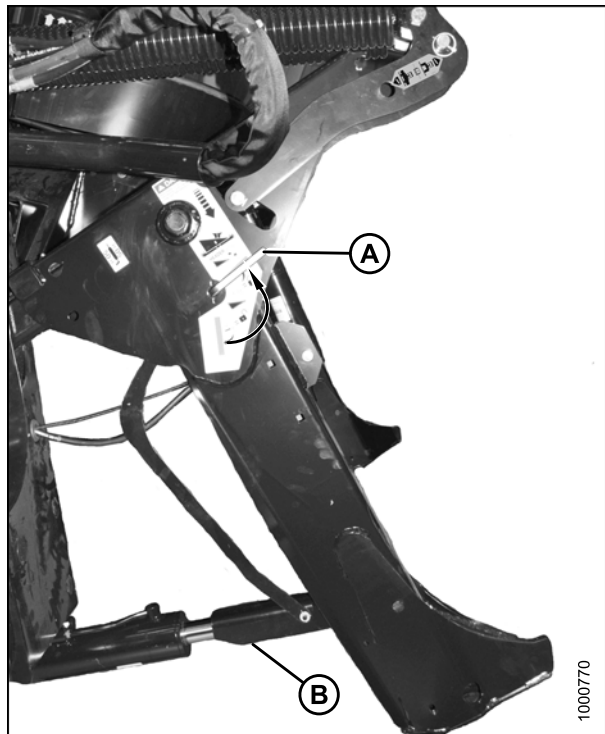

Figure 3.86: Safety Prop

ASSEMBLING THE WINDROWER

12. Install clevis pin (A) through boot and foot and secure with hairpin. Repeat for opposite boot.

IMPORTANT:

Ensure clevis pin (A) is fully inserted and hairpin is installed behind bracket.

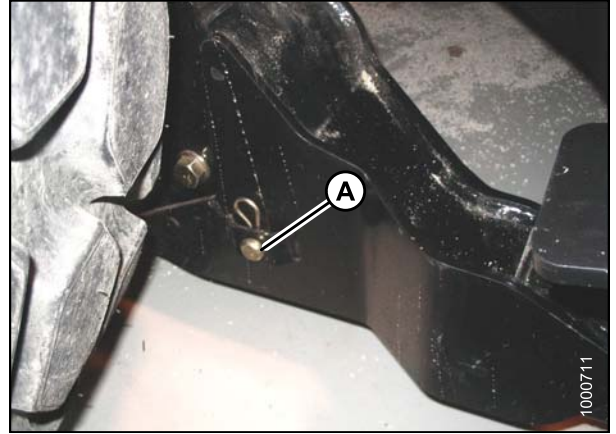

Figure 3.87: Header Boot

13. Remove lynch pin from clevis pin (A) in stand (B).
14. Hold stand (B) and remove pin (A).
15. Move stand (B) to storage position by inverting and relocating onto bracket as shown. Reinsert clevis pin (A) and secure with lynch pin.

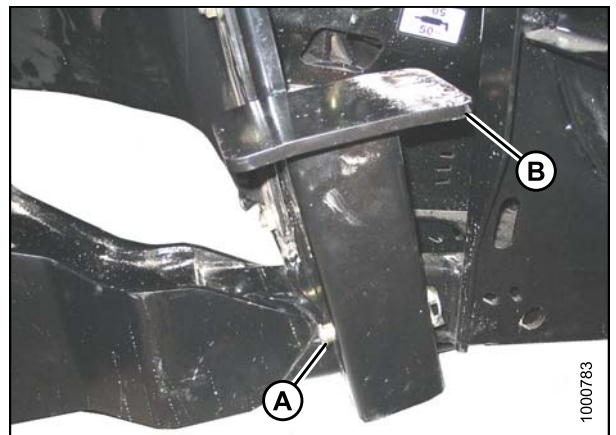

Figure 3.88: Header Stand

16. Remove clevis pin from storage position (B) in linkage and insert into hole (A) to engage float springs. Secure with hairpin.

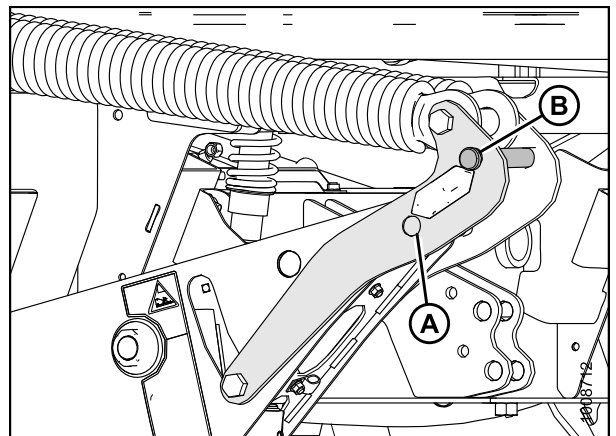

Figure 3.89: Header Float Linkage

ASSEMBLING THE WINDROWER

17. Disengage safety prop by turning lever (A) downwards to release and lower stop until lever locks into vertical position.
18. Repeat for opposite safety prop.

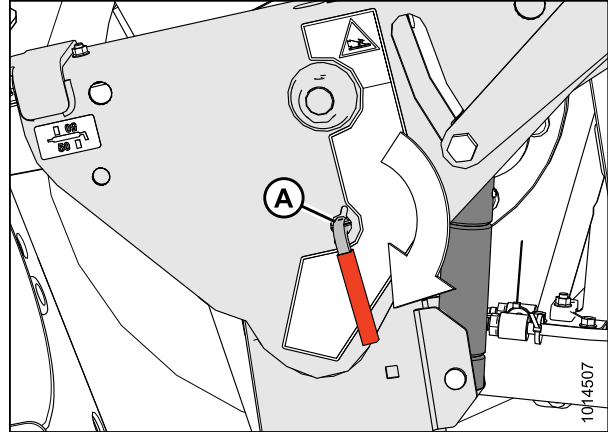

Figure 3.90: Safety Prop

CAUTION

Check to be sure all bystanders have cleared the area.

19. Start the engine and activate the HEADER DOWN switch (A) on the GSL to fully lower the header.
20. Stop engine and remove key from ignition.

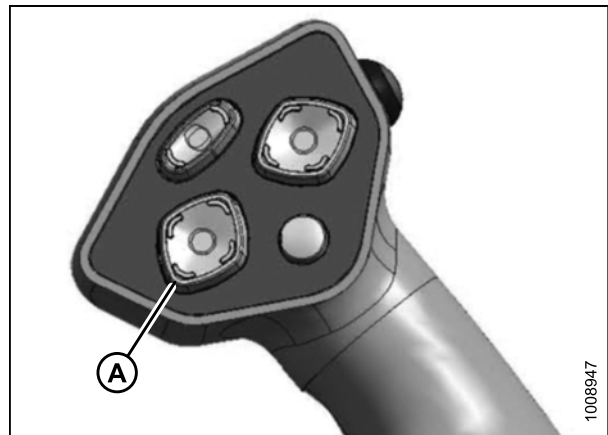

Figure 3.91: Ground Speed Lever

21. Connect header drive hoses (A) and electrical harness (B) to header. Refer to the auger header operator's manual.

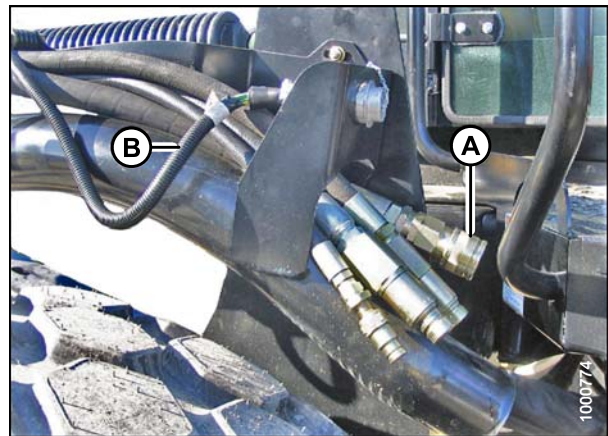

Figure 3.92: Header Drive Hoses and Harness

3.9.4 Attaching an R-Series Header

Only a 13-foot R-Series Rotary Disc Header (R80 and R85) can be attached to an M155E4 Self-Propelled Windrower.

The M155E4 Self-Propelled Windrower can operate 13-foot R80 and R85 Rotary Disc Headers **only**. These headers are shipped without the motor or hoses installed, so a separate motor, hose bundle, and hydraulic valve kit is required to operate the header.

If necessary, obtain the following kits and install them in accordance with the instructions supplied with the kits.

Table 3.2 Rotary Disc Header Bundles

Kit Description	Kit Number
Hydraulic Drive kit	MD #B5510
Hydraulic Valve kit	MD #B4657

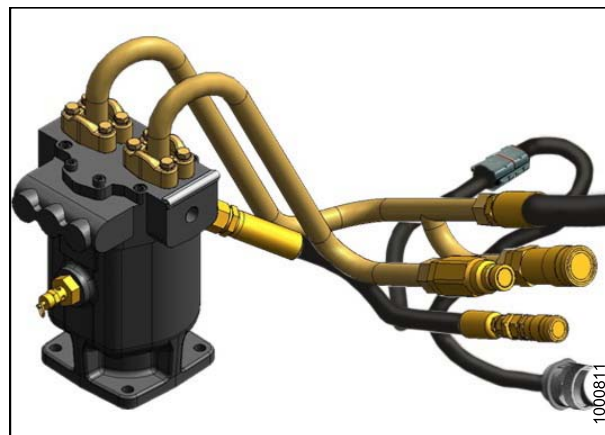

Figure 3.93: Hydraulic Drive Kit (MD #B5510)

Refer to the following instructions based on the type of center-link installed on your windrower:

- [Attaching an R-Series Header: Hydraulic Center-Link with Optional Self-Alignment, page 51](#)
- [Attaching an R-Series Header: Hydraulic Center-Link without Self-Alignment, page 56](#)

Attaching an R-Series Header: Hydraulic Center-Link with Optional Self-Alignment

DANGER

To avoid bodily injury or death from unexpected startup of the machine, always stop the engine and remove the key from the ignition before leaving the operator's seat for any reason.

1. Remove hairpin (B) from clevis pin (A) and remove clevis pin from the header boots (C) on both sides of the header.

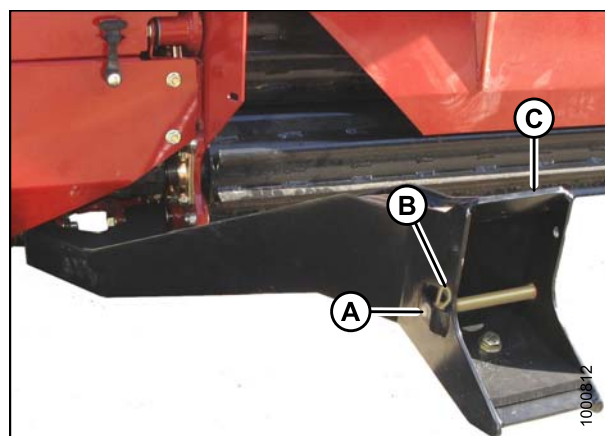

Figure 3.94: Header Boot

ASSEMBLING THE WINDROWER

CAUTION

To prevent damage to the lift system when lowering header lift linkages without a header or weight box attached to the windrower, ensure the float engagement pin is installed in storage position (B) and NOT in engaged position (A).

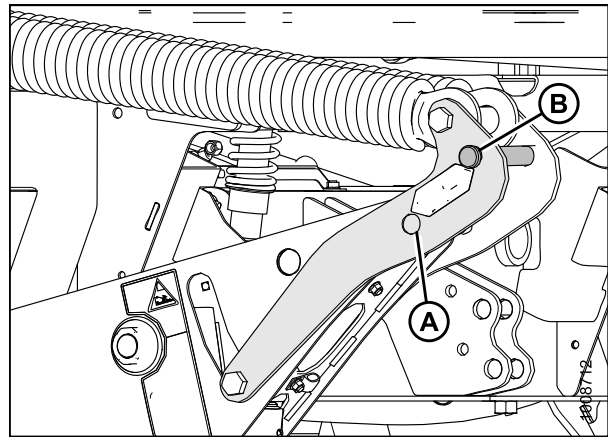

Figure 3.95: Header Float Linkage

CAUTION

Check to be sure all bystanders have cleared the area.

IMPORTANT:

Remove protective cover from exhaust stack prior to starting engine.

2. Start the engine and activate the HEADER DOWN button (A) on the ground speed lever (GSL) to fully retract header lift cylinders.

IMPORTANT:

If the center-link is too low, it may contact the header as the windrower approaches the header for hookup.

3. Activate the REEL UP switch (A) on the GSL to raise the center-link until the hook is above the attachment pin on the header.

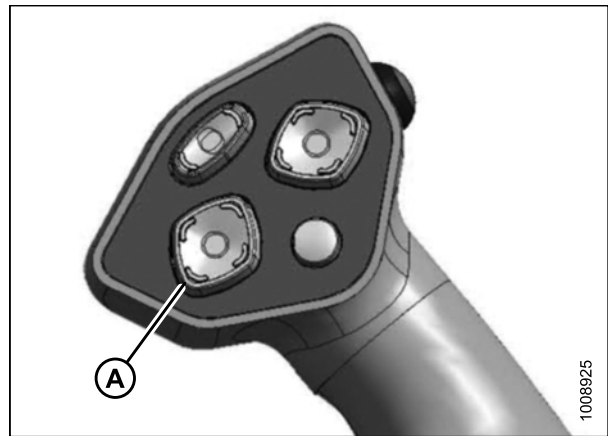

Figure 3.96: Ground Speed Lever

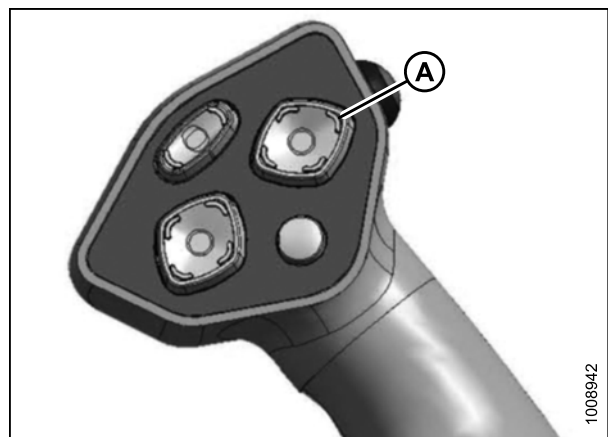

Figure 3.97: Ground Speed Lever

ASSEMBLING THE WINDROWER

4. Drive the windrower slowly forward until the windrower feet (A) enter the header boots (B). Continue driving slowly forward until the feet engage the boots and the header nudges forward.

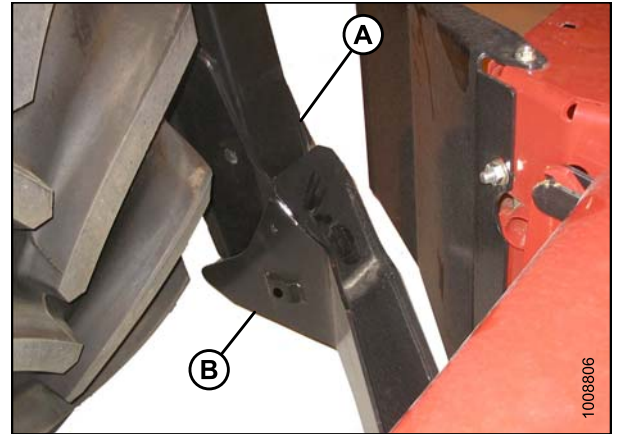

Figure 3.98: Header Boot

5. Use the following GSL functions to position the center-link hook above the header attachment pin:
 - Reel up (A) to raise the center-link
 - Reel down (B) to lower the center-link
 - Header tilt up (C) to retract the center-link
 - Header tilt down (D) to extend the center-link

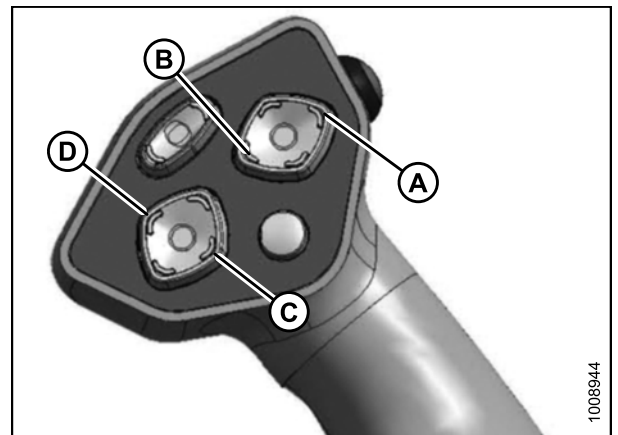

Figure 3.99: Ground Speed Lever

6. Adjust position of the center-link cylinder (A) with the REEL UP and REEL DOWN switches on the GSL until the hook is positioned above the header attachment pin.

IMPORTANT:

Hook release must be down to enable self-locking mechanism. If the release is open (up), manually push it down after hook engages header pin.

7. Lower center-link (A) onto the header with REEL DOWN switch until it locks into position (hook release [B] is down).
8. Check that center-link is locked onto header by pressing the REEL UP switch on the GSL.

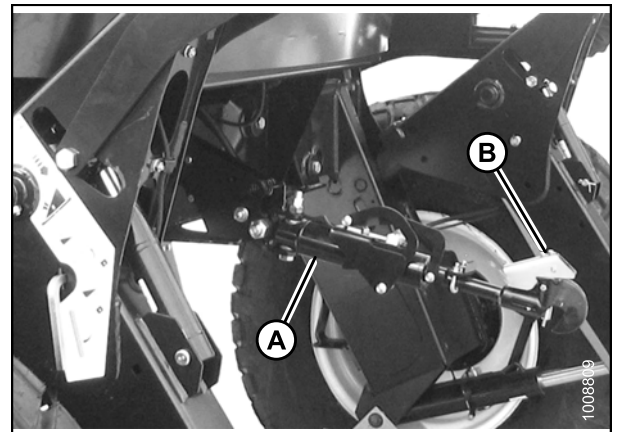

Figure 3.100: Hydraulic Center-Link

ASSEMBLING THE WINDROWER

CAUTION

Check to be sure all bystanders have cleared the area.

9. Press the HEADER UP switch (A) to raise header to maximum height.

NOTE:

If one end of the header does **NOT** fully rise, rephase the lift cylinders as follows:

- a. Press and hold the HEADER UP switch until both cylinders stop moving.
- b. Continue to hold the switch for 3–4 seconds. Cylinders are now phased.

NOTE:

It may be necessary to repeat this procedure if there is air in the system.

10. Engage safety props on both lift cylinders as follows:
 - a. Stop engine and remove key from ignition.
 - b. Pull lever (A) and rotate towards the header to release and lower safety prop (B) onto the lift cylinder.
 - c. Repeat for opposite lift cylinder.

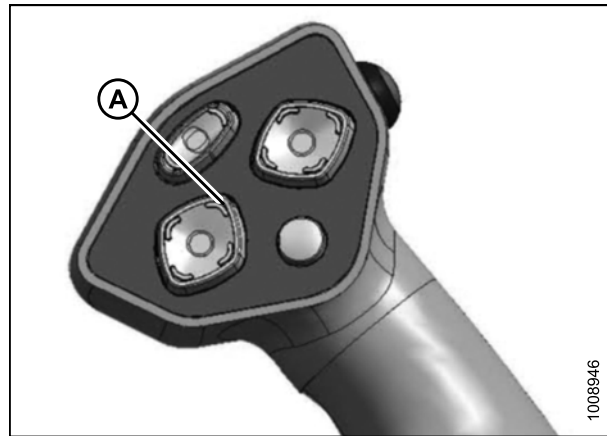

Figure 3.101: Ground Speed Lever

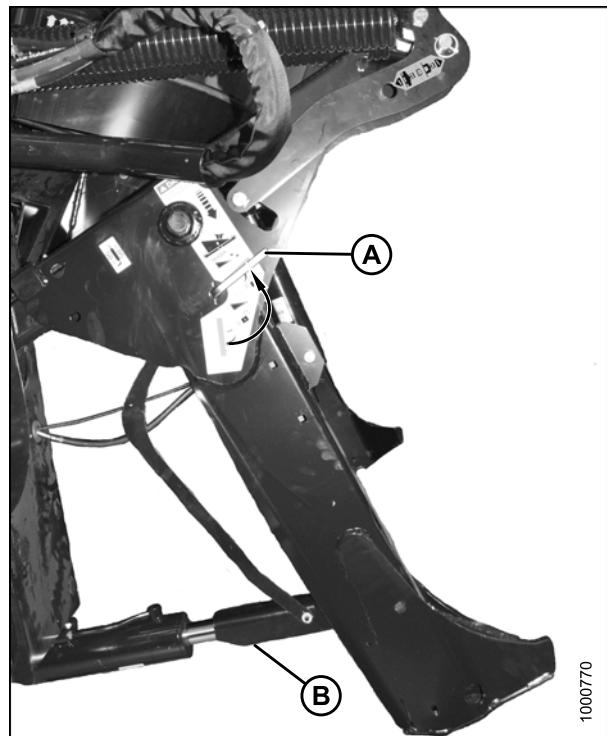

Figure 3.102: Safety Prop

ASSEMBLING THE WINDROWER

11. Install clevis pin (A) through boot and foot and secure with hairpin (B). Repeat for opposite side.

IMPORTANT:

Ensure clevis pin (A) is fully inserted and hairpin is installed behind bracket.

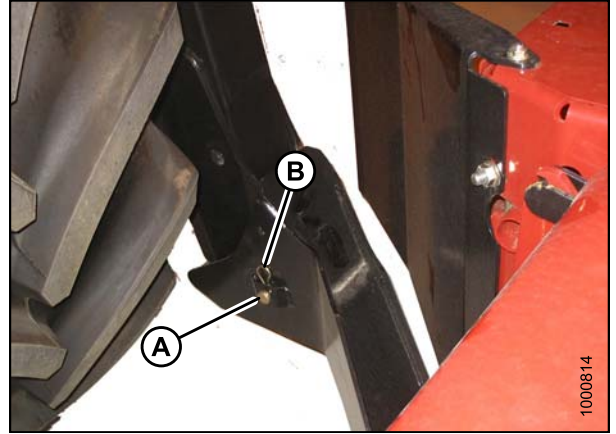

Figure 3.103: Header Boot

12. Remove clevis pin from storage position (B) in linkage and insert into hole (A) to engage float springs. Secure with hairpin.

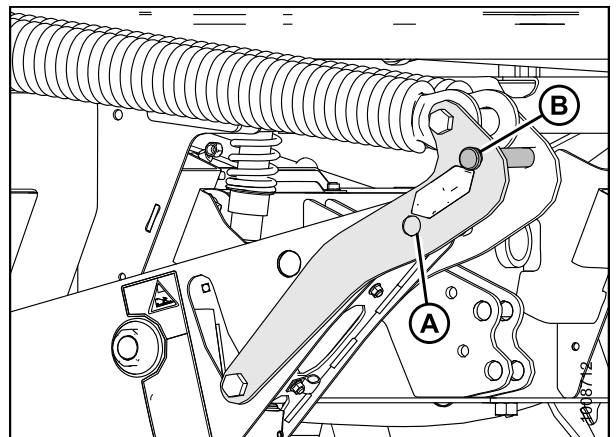

Figure 3.104: Header Float Linkage

13. Disengage safety prop by turning lever (A) downwards to release and lower stop until lever locks into vertical position.
14. Repeat for opposite safety prop.

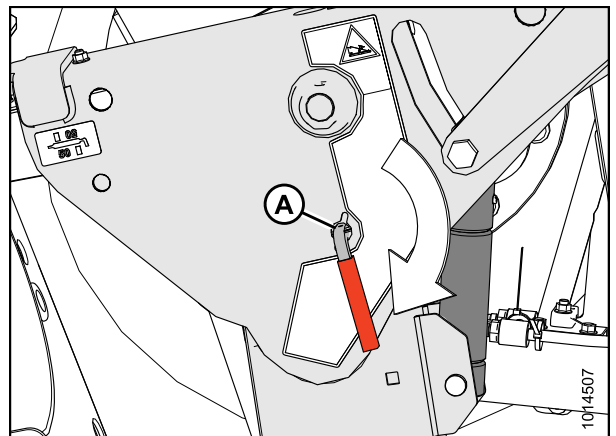

Figure 3.105: Safety Prop

ASSEMBLING THE WINDROWER

CAUTION

Check to be sure all bystanders have cleared the area.

15. Start the engine and activate the HEADER DOWN switch (A) on the GSL to fully lower the header.
16. Stop engine and remove key from ignition.

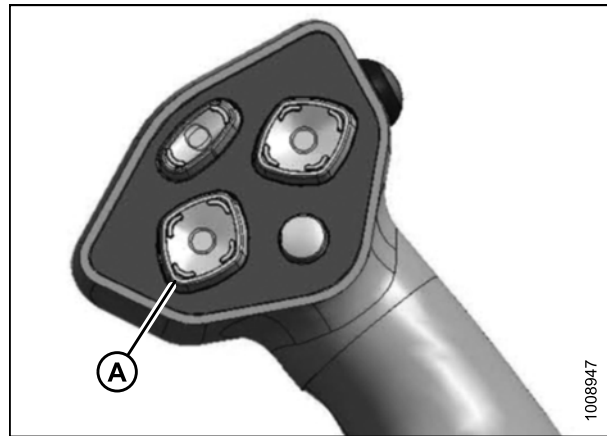

Figure 3.106: Ground Speed Lever

17. Connect header drive hoses (A) and electrical harness (B) to header. Refer to the rotary disc header operator's manual.

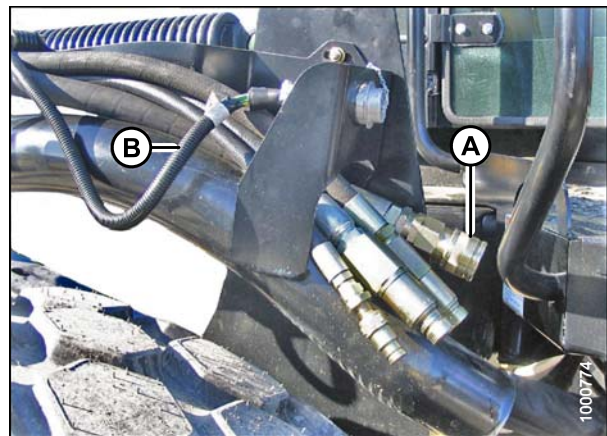

Figure 3.107: Header Drive Hoses and Harness

Attaching an R-Series Header: Hydraulic Center-Link without Self-Alignment

DANGER

To avoid bodily injury or death from unexpected startup of the machine, always stop the engine and remove the key from the ignition before leaving the operator's seat for any reason.

1. Remove hairpin (B) from clevis pin (A) and remove clevis pin from the header boots (C) on both sides of the header.

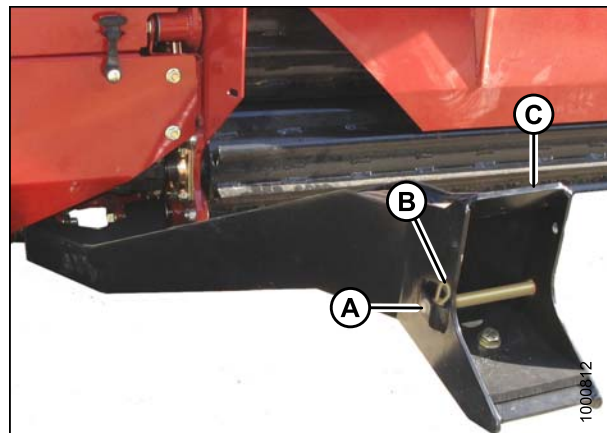

Figure 3.108: Header Boot

ASSEMBLING THE WINDROWER

CAUTION

To prevent damage to the lift system when lowering header lift linkages without a header or weight box attached to the windrower, ensure the float engagement pin is installed in storage position (B) and NOT in engaged position (A).

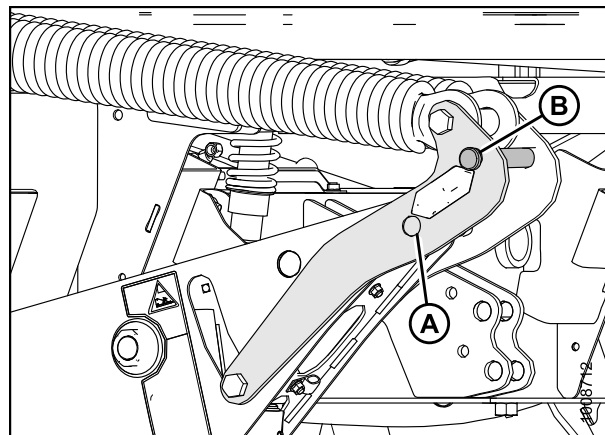

Figure 3.109: Header Float Linkage

CAUTION

Check to be sure all bystanders have cleared the area.

IMPORTANT:

Remove protective cover from exhaust stack prior to starting engine.

2. Start the engine and activate the HEADER DOWN button (A) on the ground speed lever (GSL) to fully retract header lift cylinders.



Figure 3.110: Ground Speed Lever

3. Relocate pin (A) in frame linkage as required to raise the center-link (B) until the hook is above the attachment pin on the header.

IMPORTANT:

If the center-link is too low, it may contact the header as the windrower approaches the header for hookup.

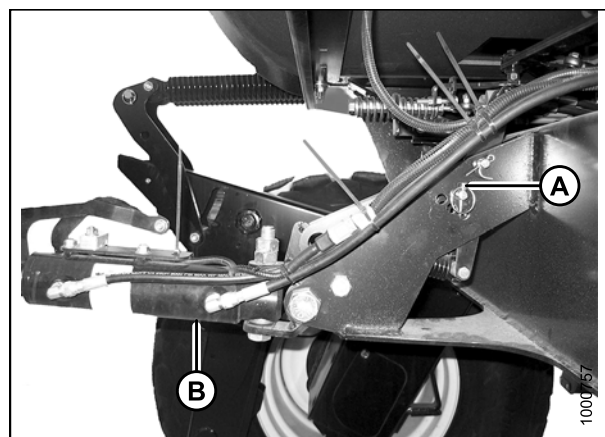

Figure 3.111: Hydraulic Center-Link without Self-Alignment Kit

ASSEMBLING THE WINDROWER

4. Drive the windrower slowly forward until the windrower feet (A) enter the header boots (B). Continue driving slowly forward until the feet engage the boots and the header nudges forward.

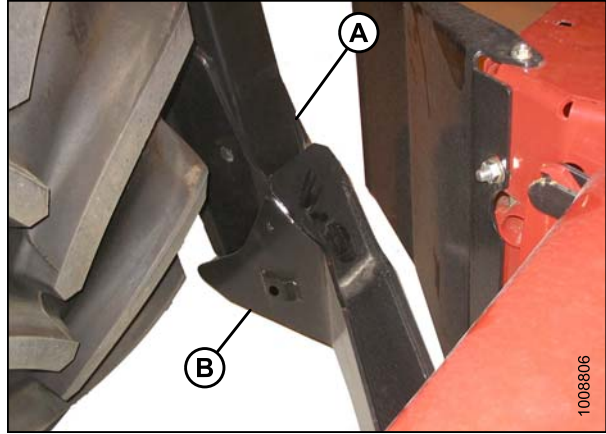

Figure 3.112: Header Boot

5. Use the following GSL functions to position the center-link hook above the header attachment pin:
 - Header tilt up (A) to retract the center-link
 - Header tilt down (B) to extend the center-link
6. Stop engine and remove key from ignition.

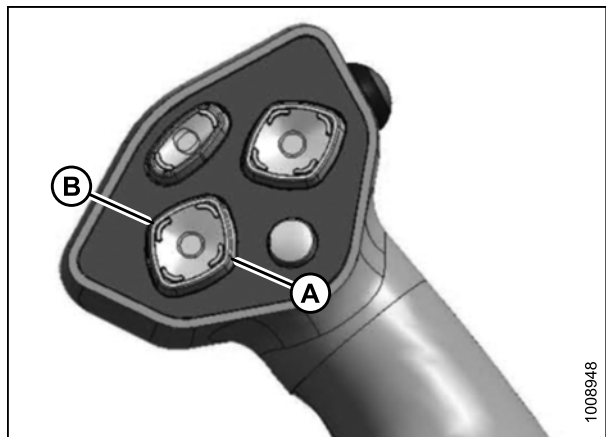

Figure 3.113: Ground Speed Lever

7. Push down on rod end of link cylinder (B) until hook engages and locks onto header pin.

IMPORTANT:

Hook release must be down to enable self-locking mechanism. If the release is open (up), manually push it down after hook engages header pin.

8. Check that center-link (A) is locked onto header by pulling upward on rod end (B) of cylinder.

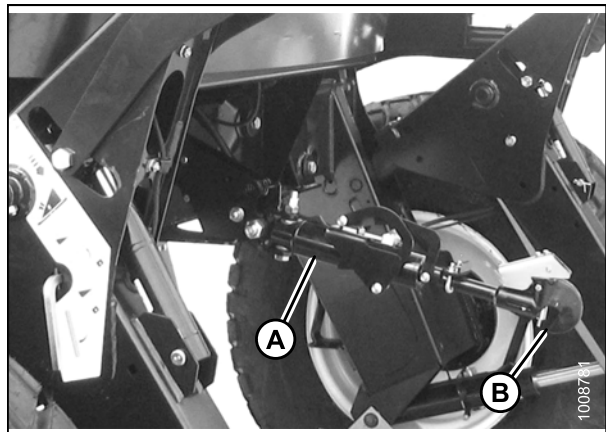

Figure 3.114: Hydraulic Center-Link

ASSEMBLING THE WINDROWER

CAUTION

Check to be sure all bystanders have cleared the area.

9. Start the engine.
10. Press the HEADER UP switch (A) to raise header to maximum height.

NOTE:

If one end of the header does **NOT** fully rise, rephase the lift cylinders as follows:

- a. Press and hold the HEADER UP switch until both cylinders stop moving.
- b. Continue to hold the switch for 3–4 seconds. Cylinders are now phased.

NOTE:

It may be necessary to repeat this procedure if there is air in the system.

11. Engage safety props on both lift cylinders as follows:
 - a. Stop engine and remove key from ignition.
 - b. Pull lever (A) and rotate towards the header to release and lower safety prop (B) onto the lift cylinder.
 - c. Repeat for opposite lift cylinder.

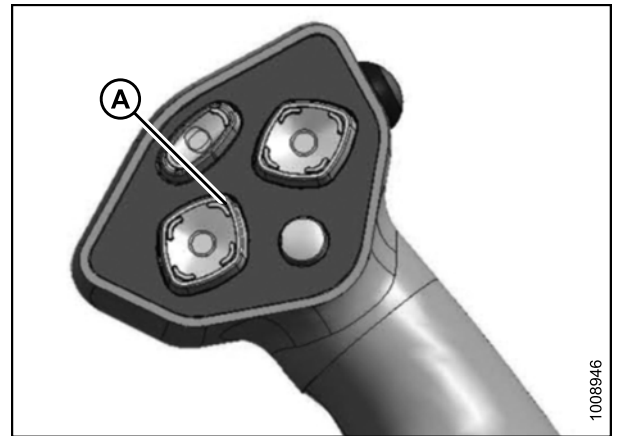

Figure 3.115: Ground Speed Lever

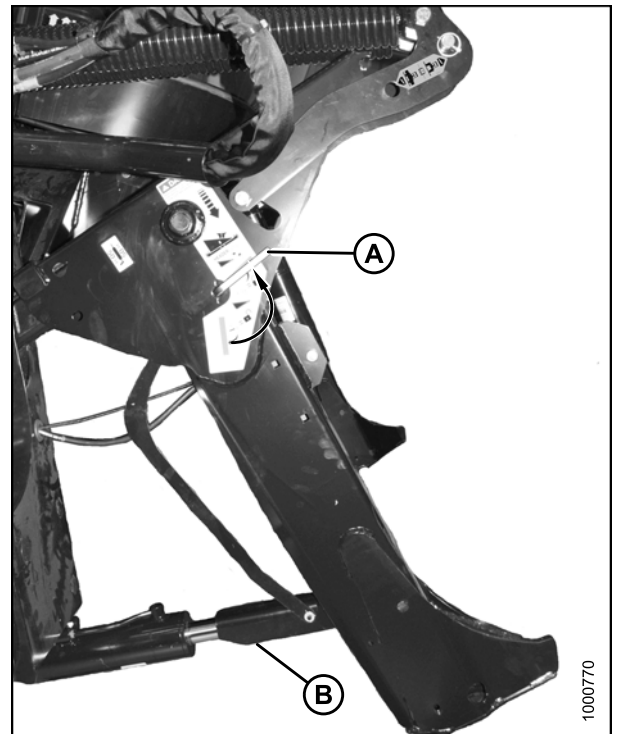

Figure 3.116: Safety Prop

ASSEMBLING THE WINDROWER

12. Install clevis pin (A) through boot and foot and secure with hairpin (B). Repeat for opposite side.

IMPORTANT:

Ensure clevis pin (A) is fully inserted and hairpin is installed behind bracket.

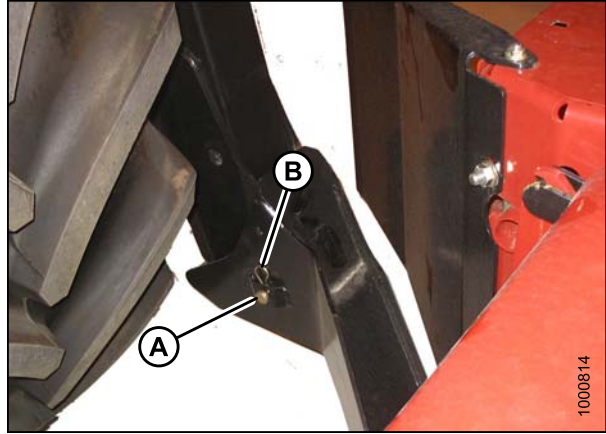

Figure 3.117: Header Boot

13. Remove clevis pin from storage position (B) in linkage and insert into hole (A) to engage float springs. Secure with hairpin.

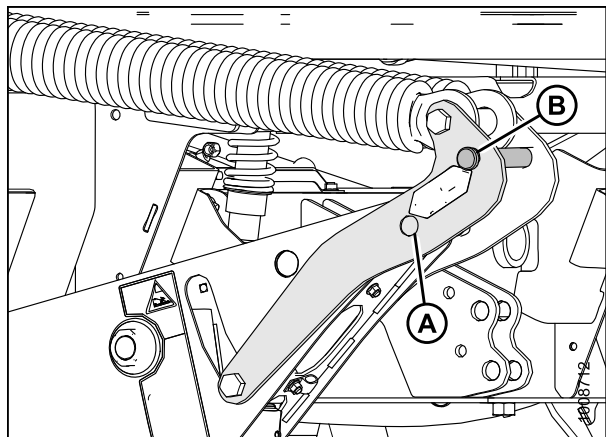

Figure 3.118: Header Float Linkage

14. Disengage safety prop by turning lever (A) downwards to release and lower stop until lever locks into vertical position.
15. Repeat for opposite safety prop.

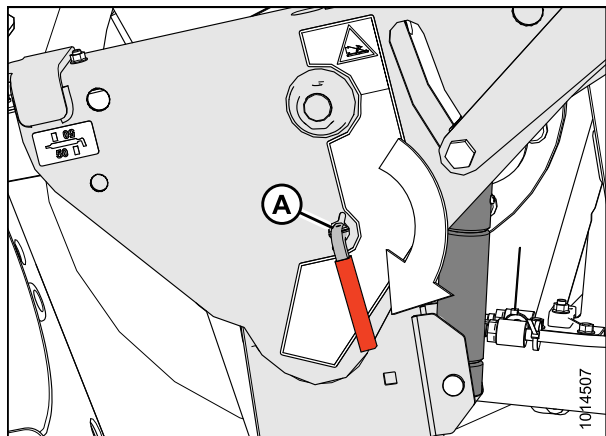

Figure 3.119: Safety Prop

ASSEMBLING THE WINDROWER

CAUTION

Check to be sure all bystanders have cleared the area.

16. Start the engine and activate the HEADER DOWN switch (A) on the GSL to fully lower the header.
17. Stop engine and remove key from ignition.

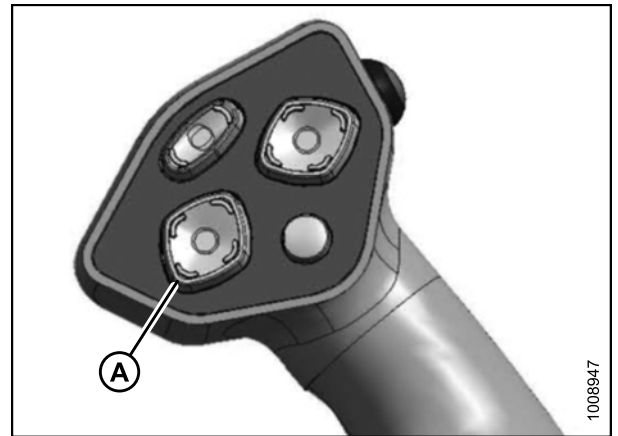

Figure 3.120: Ground Speed Lever

18. Connect header drive hoses (A) and electrical harness (B) to header. Refer to the rotary disc header operator's manual.

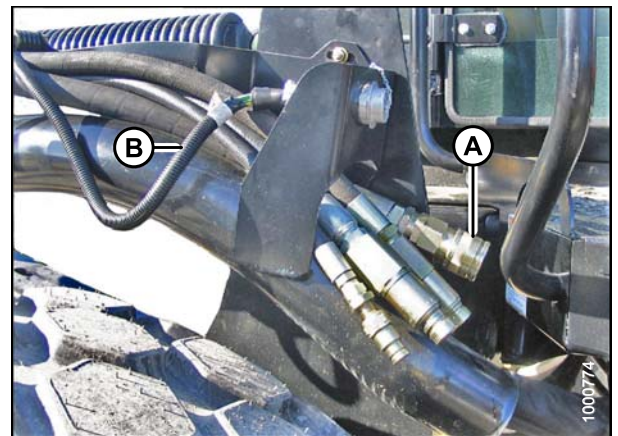

Figure 3.121: Header Drive Hoses and Harness

3.10 Lubricating the Windrower

Table 3.3 Recommended Lubricant

Specification	Description	Use
SAE Multi-Purpose	High temperature, extreme pressure (EP2) performance with 1% max molybdenum disulphide (NLGI Grade 2) lithium base	As required unless otherwise specified.

3.10.1 Lubrication Procedure

 **DANGER**

To avoid bodily injury or death from unexpected startup of the machine, always stop the engine and remove the key from the ignition before leaving the operator's seat for any reason.

1. Wipe grease fitting with a clean cloth before greasing to avoid injecting dirt and grit.
2. Inject grease through fitting with grease gun until grease overflows fitting. Do **NOT** overgrease wheel bearings.
3. Leave excess grease on fitting to keep out dirt.
4. Replace any loose or broken fittings immediately.
5. Remove and thoroughly clean any fitting that will not take grease. Also clean lubricant passageway. Replace fitting if necessary.

3.10.2 Lubrication Points

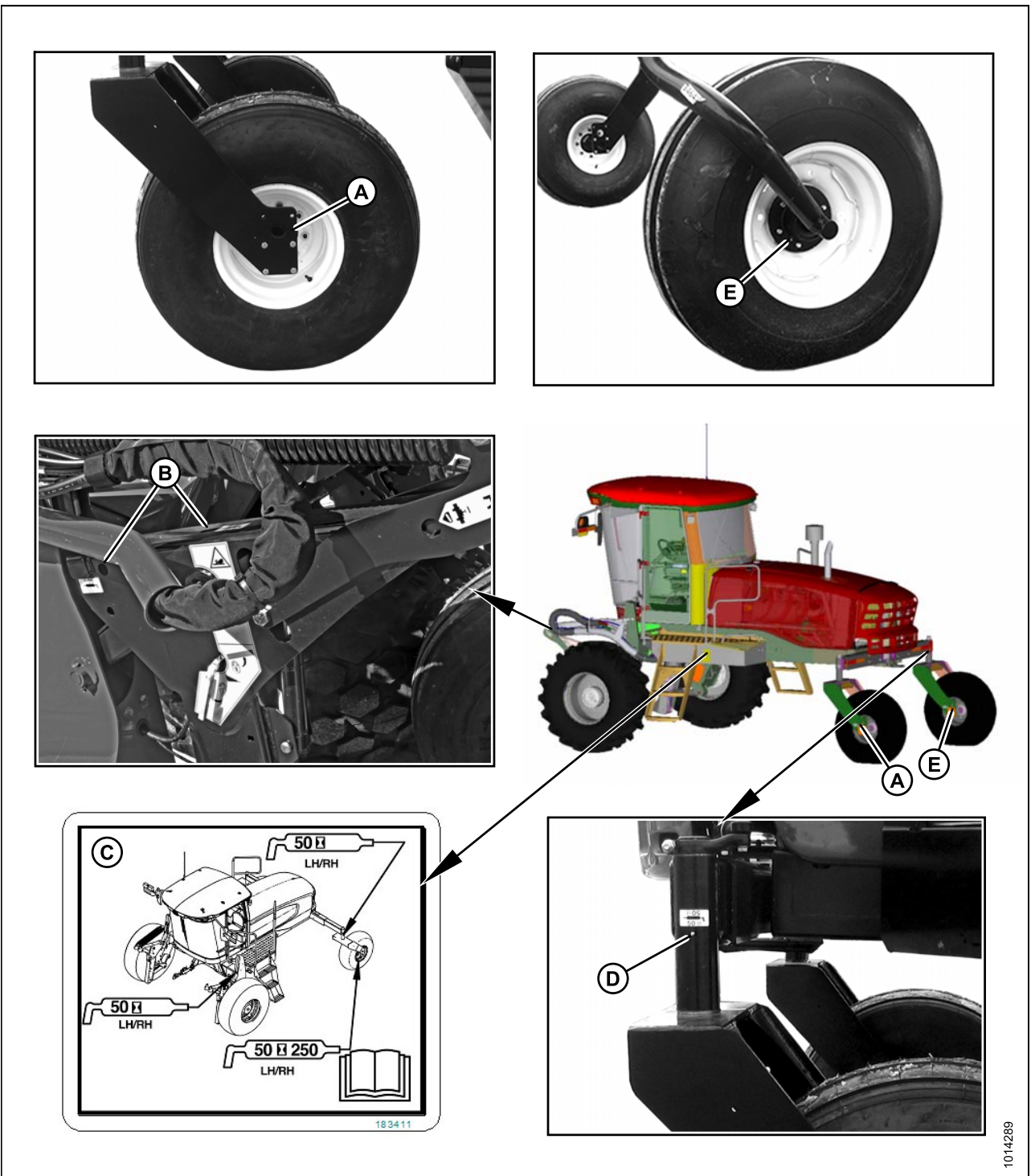

Figure 3.122: Lubrication Points

- A - Forked Caster Wheel Bearing (Two Places) (Outer – Both Wheels)
- B - Top-Link (2 Places) (Both Sides)
- C - Lubrication Decal (MD #183411)
- D - Caster Pivot (Both Sides)
- E - Forked/Formed Caster Wheel Bearing (Two Places) (Inner – Both Wheels) (50 Hrs/250 Hrs)

1014289

3.11 Fuel and Diesel Exhaust Fluid (DEF) Display Module



Figure 3.123: Fuel and Diesel Exhaust Fluid (DEF) Display Module

A - Fuel and DEF Level

B - High Exhaust System Temperature (HEST)

C - Inhibit Selective Catalytic Reduction (SCR) System Cleaning

D - Force SCR System Cleaning

Fuel and DEF level

- Level gauge appears green when levels are between full and 1/8, and appears red when levels are between 1/8 and empty.
- When the levels are in the green range, switches (icons) appear white. When the levels are in the red range, switches (icons) turn black and are backlit with amber light. The amber lights blink when the tank level is depleted to 1/16.

IMPORTANT:

Running out of DEF will cause the engine to derate and will eventually limit throttle to idle.

WARNING

Do NOT park vehicle indoors when HEST lamp is on.

- When the HEST warning is active, the switch (icon) turns black and a warning lamp is backlit with amber light at location (A) (warning lamp not shown).
- The HEST lamp appears when the engine enters a selective catalytic reduction (SCR) system cleaning—this will not hinder normal vehicle operation.
- When the HEST warning is inactive, the switch (icon) is not visible and will appear entirely black (A).

IMPORTANT:

A forced system cleaning can only be initiated if the Operator is prompted by a flashing icon. A forced system cleaning cannot be initiated at other times.

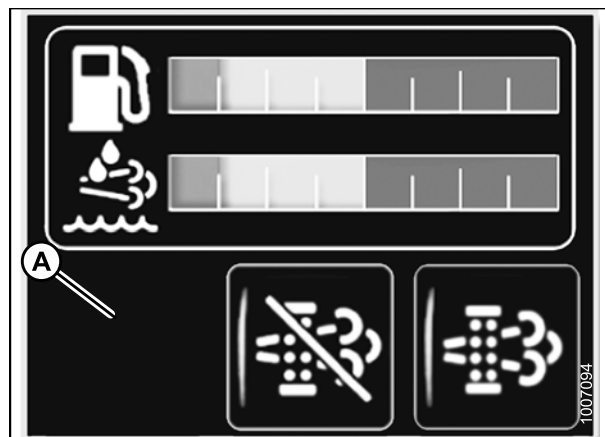

Figure 3.124: Inactive HEST Icon

SCR System Cleaning Inhibit and SCR System Cleaning Forced

SCR system cleaning is a high-temperature clean-out cycle to keep the after-treatment free of crystallized DEF.

A passive system cleaning may occur depending on engine duty cycles, and may last for 15–30 minutes. It will not have an impact on operation other than high exhaust temperature. A forced SCR system cleaning may be required for extensive clean-out (e.g., when the inhibit switch has been left ON for a long period of time). The system will derate if the forced SCR system cleaning is not done.

- Switches (icons) (A) and (B) work as lamps and switches.
- The switches (icons) turn gray when the function is not active. When the function is active, the switches (icons) turn black and are backlit with amber light.
- To activate the functions, press and hold the switch (icon) (SCR system cleaning inhibit [A] or SCR system cleaning forced [B]) for 3 seconds. During the 3-second interval, the fuel icon and gauge are replaced with the following red text at location (C), HOLD 3 SECONDS, and the red border turns white. After which, the fuel gauge returns and the white border starts blinking. The border reverts to solid red when the switch (icon) is released.

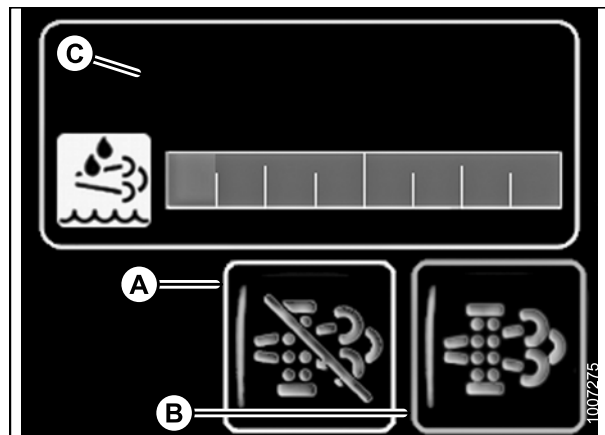

Figure 3.125: SCR System Cleaning Icons

ASSEMBLING THE WINDROWER

IMPORTANT:

- SCR System Cleaning inhibit (A) allows the Operator to temporarily prevent the machine from performing an SCR System Cleaning. It should be used only when the environment is unsafe to allow high exhaust temperatures (e.g., inside of a building).
- SCR System Cleaning Forced (B) will rarely require activation by the Operator. If required, the switch (icon) will flash amber. If the SCR System Cleaning Forced switch (icon) begins to flash, park the windrower outside in a safe environment for high exhaust temperatures. Place the ground speed lever (GSL) in N-Detent, throttle to idle, and press and hold the SCR System Cleaning Forced switch (icon) for 3 seconds. The engine will then take over throttle control. During the 3-second interval, the fuel icon and gauge will be replaced with the following red text, HOLD 3 SECONDS (C), and the red border will turn white. After which, the fuel gauge will return and the white border will start blinking. The border will revert to solid red when the switch (icon) is released.

4 Cab Display Module (CDM)

Although the other procedures in this manual are intended to be followed in the order in which they are listed, the sections in this chapter can be referred to in any order according to your specific requirements.

4.1 Cab Display Module (CDM) Programming



Figure 4.1: CDM

A - Side Display
D - Menu Item Scroll Forward

B - Main Display
E - Menu Item Scroll Backward

C - Select Switch
F - Program Switch

Side Display: Displays software revision status.

- Upper Line – C### (CDM)
- Lower Line – E### (WCM)

Main Display: Displays menu item and selection⁴.

- Upper Line – Menu Item
- Lower Line – Selection

Select Switch: Places monitor into Program Mode with PROGRAM switch. Press to accept menu item and advance to next item.

Menu Item Scroll Forward: Displays value under menu item.

- Push to scroll forward
- Hold down for fast scroll⁵

4. The current selection is flashing.

5. Fast scroll applies only when changing KNIFE SPEED, OVERLOAD PRESSURE, and TIRE SIZE.

CAB DISPLAY MODULE (CDM)

Menu Item Scroll Backward: Displays value under menu item.

- Push to scroll backward
- Hold down for fast scroll⁵

Program Switch: Places monitor into program mode. Press while pressing select switch.

NOTE:

The following menus are available when ignition key is set to RUN:

- WINDROWER SETUP
- CAB DISPLAY SETUP
- DIAGNOSTIC MODE

The CALIBRATE SENSORS menu is available only when engine is running.

4.2 Cab Display Options

The display and sound features of the cab display module (CDM) can be adjusted to suit each particular Operator.

NOTE:

The procedures listed in this section are current for cab display module (CDM) software version C507 and windrower control module (WCM) E228. The WCM is supplied preloaded with the latest released version of the operating software. Any subsequent updates will be made available via internet download from the MacDon Dealer Portal (<https://portal.macdon.com>).

NOTE:

Screens may appear differently if running newer or older versions of software, and not all features are available on every machine.

4.2.1 Setting the Cab Display Language

1. Turn ignition key to RUN, or start the engine.
2. Press PROGRAM (A) and SELECT (C) on cab display module (CDM) to enter Programming Mode.
 - WINDROWER SETUP? is displayed on the upper line.
 - NO/YES is displayed on the lower line.

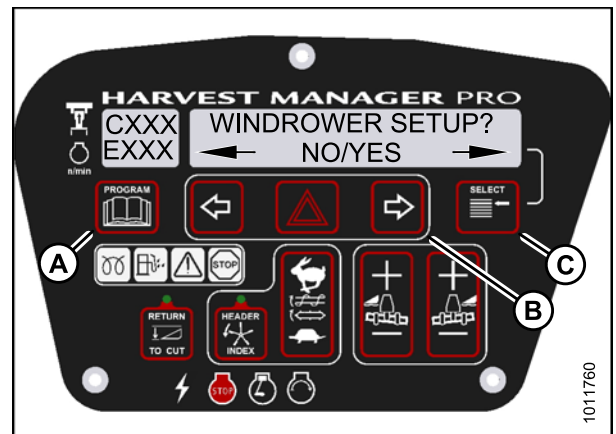

Figure 4.2: CDM Programming Buttons

3. Press SELECT (B) until CAB DISPLAY SETUP? is displayed on the upper line.
 - NO/YES is displayed on the lower line.

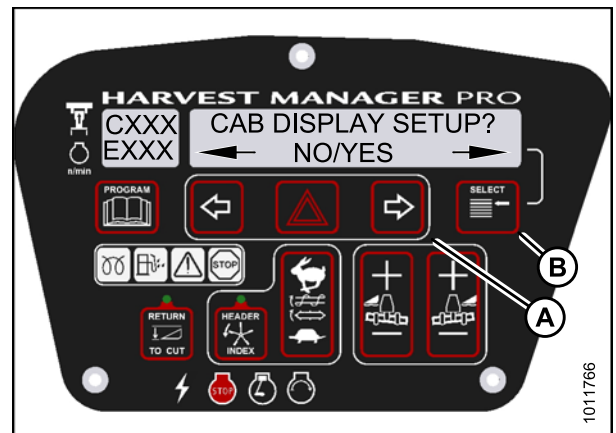

Figure 4.3: Cab Display Setup

CAB DISPLAY MODULE (CDM)

- Press right (C) arrow select YES. Press SELECT (D).
 - DISPLAY LANGUAGE? is displayed on the upper line.
 - Default language is displayed on the lower line.
- Press left (B) or right (C) arrow to select preferred language.

NOTE:

English, Russian, and Spanish language options are available on windrowers. Not all language options are available on all windrowers.

- Press PROGRAM (A) to exit Programming Mode or press SELECT (D) to proceed to next CAB DISPLAY SETUP? action.



Figure 4.4: Display Language

4.2.2 Changing the Windrower Display Units

- Turn ignition key to RUN, or start the engine.
- Press PROGRAM (A) and SELECT (C) on cab display module (CDM) to enter Programming Mode.
 - WINDROWER SETUP? is displayed on the upper line.
 - NO/YES is displayed on the lower line.

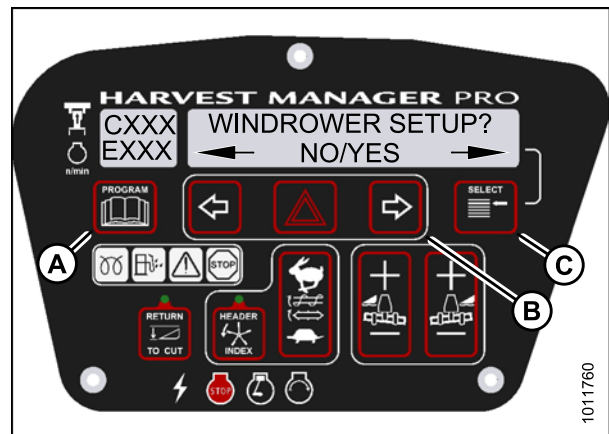

Figure 4.5: CDM Programming Buttons

- Press SELECT (B) until CAB DISPLAY SETUP? is displayed on the upper line.
 - NO/YES is displayed on the lower line.
- Press right (A) arrow to select YES. Press SELECT (B).
 - DISPLAY LANGUAGE? is displayed on the upper line.

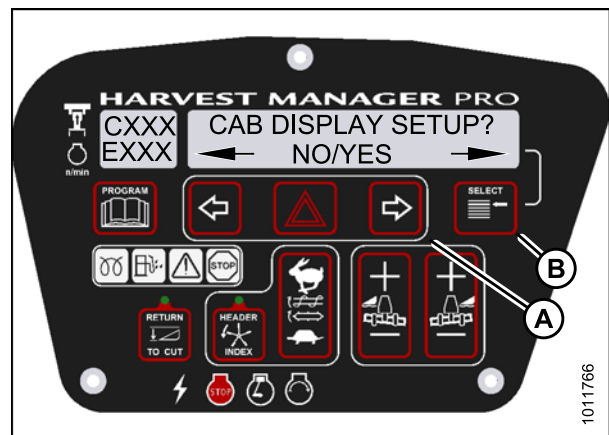

Figure 4.6: Cab Display Setup

CAB DISPLAY MODULE (CDM)

5. Press SELECT (D) until DISPLAY UNITS? is displayed on the upper line.
 - Default setting is displayed on the lower line.
6. Press left (B) or right (C) arrow to select either METRIC or IMPERIAL speed display.
7. Press PROGRAM (A) to exit Programming Mode or press SELECT (D) to proceed to next CAB DISPLAY SETUP? action.

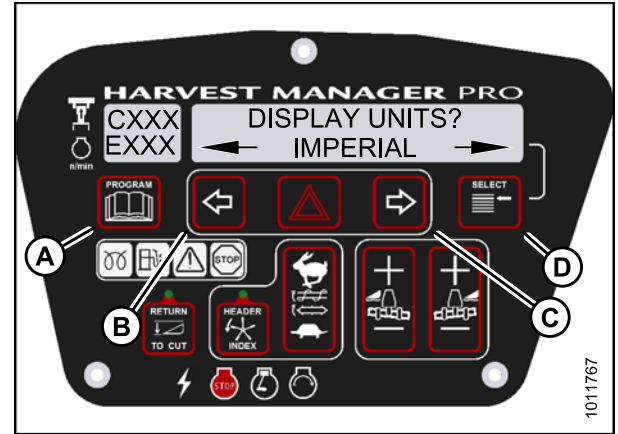

Figure 4.7: Display Units

4.2.3 Adjusting the Cab Display Buzzer Volume

1. Turn ignition key to RUN, or start the engine.
2. Press PROGRAM (A) and SELECT (C) on cab display module (CDM) to enter Programming Mode.
 - WINDROWER SETUP? is displayed on the upper line.
 - NO/YES is displayed on the lower line.

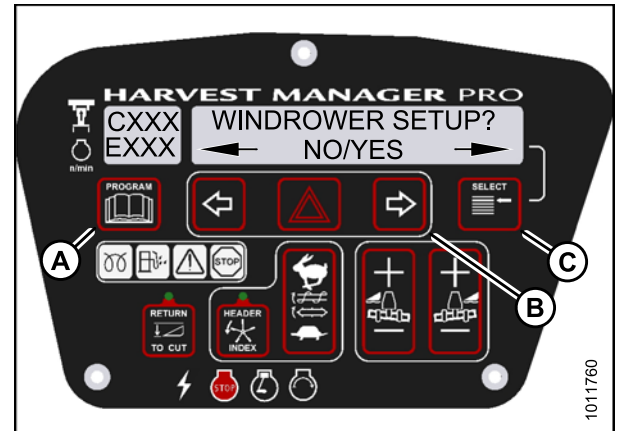

Figure 4.8: CDM Programming Buttons

3. Press SELECT (B) until CAB DISPLAY SETUP? is displayed on the upper line.
 - NO/YES is displayed on the lower line.
4. Press right (A) arrow to select YES. Press SELECT (B).
 - DISPLAY LANGUAGE? is displayed on the upper line.

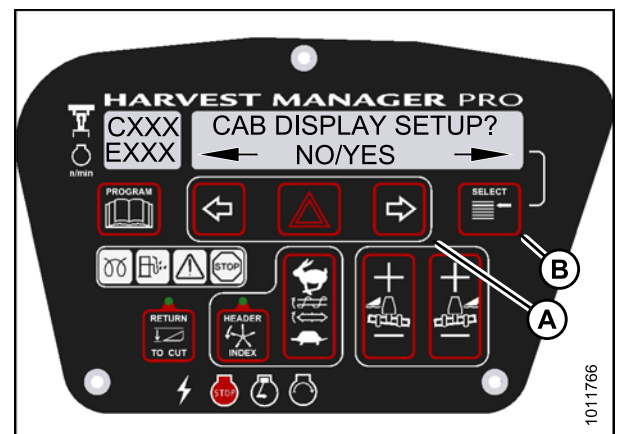

Figure 4.9: Cab Display Setup

CAB DISPLAY MODULE (CDM)

5. Press SELECT (D) until BUZZER VOLUME is displayed on the upper line.
 - Previous setting is displayed on the lower line.
6. Press left (B) or right (C) arrows to adjust buzzer volume.
7. Press PROGRAM (A) to exit Programming Mode or press SELECT (D) to proceed to next CAB DISPLAY SETUP? action.

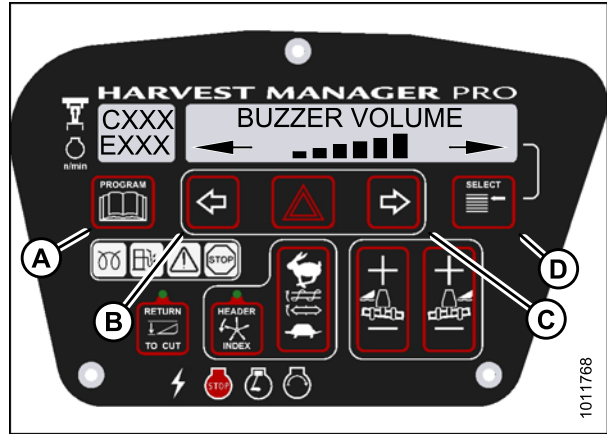

Figure 4.10: Buzzer Volume

4.2.4 Adjusting the Cab Display Backlighting

The backlighting feature brightens the display screen helping you read the cab display module (CDM) in low light situations.

1. Turn ignition key to RUN, or start the engine.
2. Press PROGRAM (A) and SELECT (C) on cab display module (CDM) to enter Programming Mode.
 - WINDROWER SETUP? is displayed on the upper line.
 - NO/YES is displayed on the lower line.

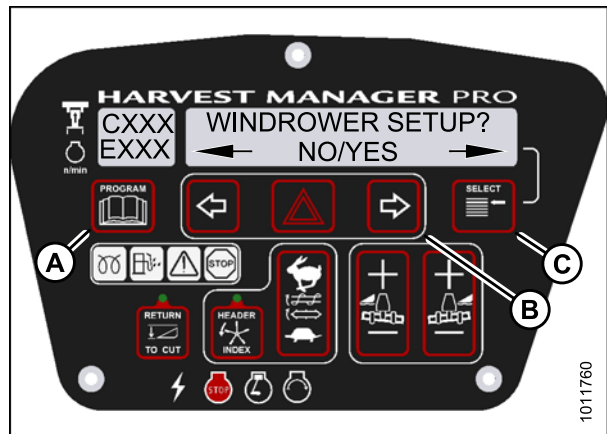

Figure 4.11: CDM Programming Buttons

3. Press SELECT (B) until CAB DISPLAY SETUP? is displayed on the upper line.
 - NO/YES is displayed on the lower line.
4. Press right (A) arrow to select YES. Press SELECT (B).
 - DISPLAY LANGUAGE? is displayed on the upper line.

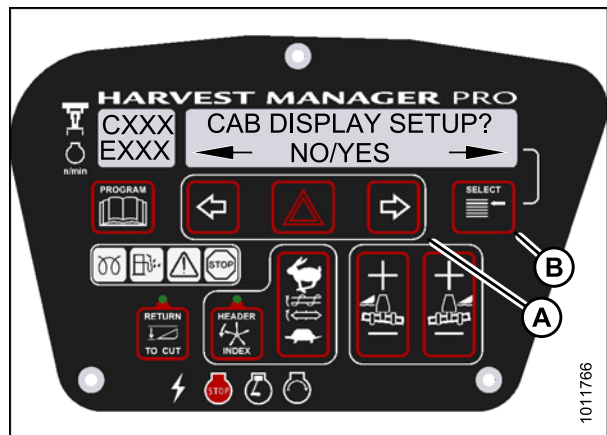

Figure 4.12: Cab Display Setup

CAB DISPLAY MODULE (CDM)

5. Press SELECT (D) until BACKLIGHTING is displayed on the upper line.
 - Default setting is displayed on the lower line.
6. Press left (B) or right (C) arrows to adjust display backlighting.
7. Press PROGRAM (A) to exit Programming Mode or press SELECT (D) to proceed to next CAB DISPLAY SETUP? action.



Figure 4.13: Backlighting

4.2.5 Adjusting the Cab Display Contrast

1. Turn ignition key to RUN, or start the engine.
2. Press PROGRAM (A) and SELECT (C) on cab display module (CDM) to enter Programming Mode.
 - WINDROWER SETUP? is displayed on the upper line.
 - NO/YES is displayed on the lower line.

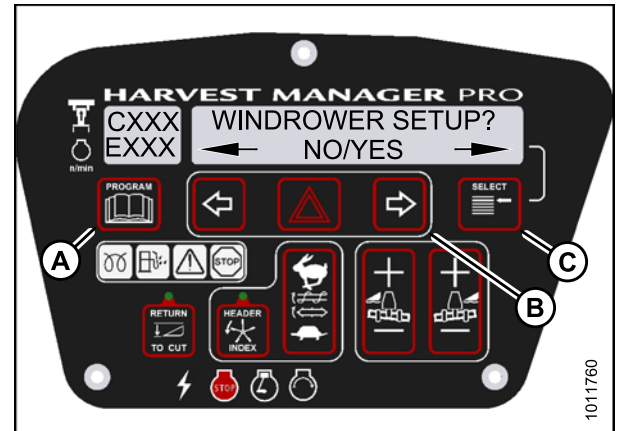

Figure 4.14: CDM Programming Buttons

3. Press SELECT (B) until CAB DISPLAY SETUP? is displayed on the upper line.
 - NO/YES is displayed on the lower line.
4. Press right (A) arrow to select YES. Press SELECT (B).
 - DISPLAY LANGUAGE? is displayed on the upper line.

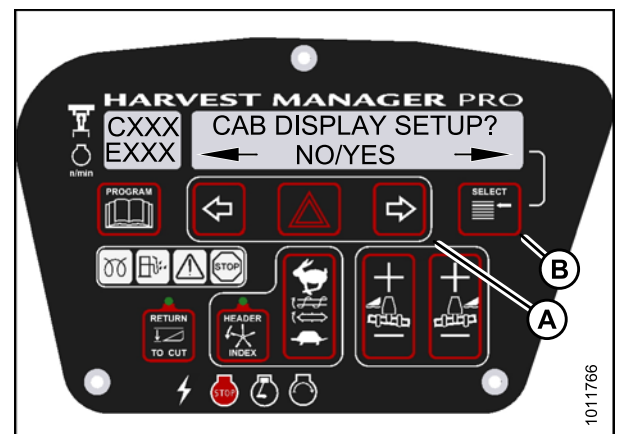

Figure 4.15: Cab Display Setup

CAB DISPLAY MODULE (CDM)

5. Press SELECT (D) until DISPLAY CONTRAST is displayed on the upper line.
 - Default setting is displayed on the lower line.
6. Press left (B) or right (C) arrows to adjust display contrast.
7. Press PROGRAM (A) to exit Programming Mode or press SELECT (D) to proceed to next CAB DISPLAY SETUP? action.

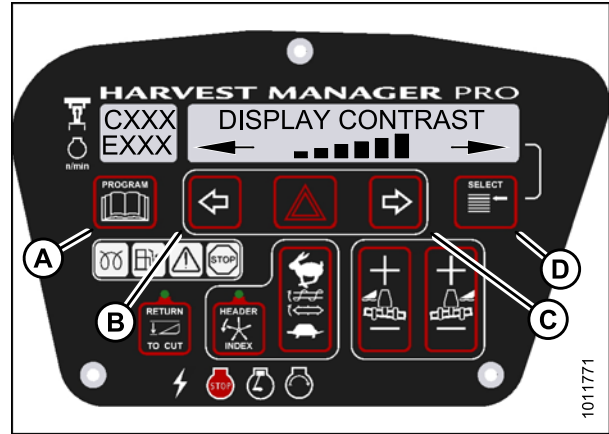

Figure 4.16: Display Contrast

4.3 Calibrating the Header Sensors

Sensor calibration programs the windrower control module (WCM) with settings for the attached header.

4.3.1 Calibrating the Header Height Sensor

NOTE:

- The header **MUST** be attached to the windrower to perform this procedure. The cab display module (CDM) automatically adjusts its programming for each header.
- The engine **MUST** be running to perform this procedure.

1. Turn ignition key to RUN, or start the engine.
2. Press PROGRAM (A) and SELECT (C) on cab display module (CDM) to enter Programming Mode.
 - WINDROWER SETUP? is displayed on the upper line.
3. Press SELECT (C) until CALIBRATE SENSORS? is displayed on the upper line.
 - NO/YES is displayed on the lower line.

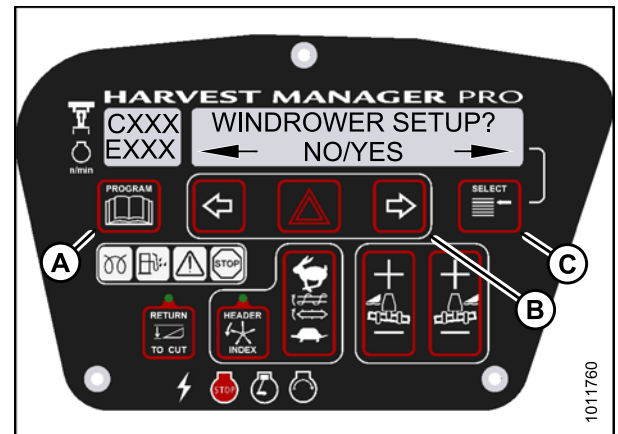

Figure 4.17: CDM Programming Buttons

4. Press right (B) arrow to select Yes. Press SELECT (C).
 - TO CALIBRATE SELECT is displayed in upper line.
5. Press left (A) or right (B) arrow until HEADER HEIGHT is displayed on the lower line. Press SELECT (C).
 - CALIBRATING HEIGHT is displayed on the upper line.
 - RAISE HEADER HOLD is displayed on the lower line.

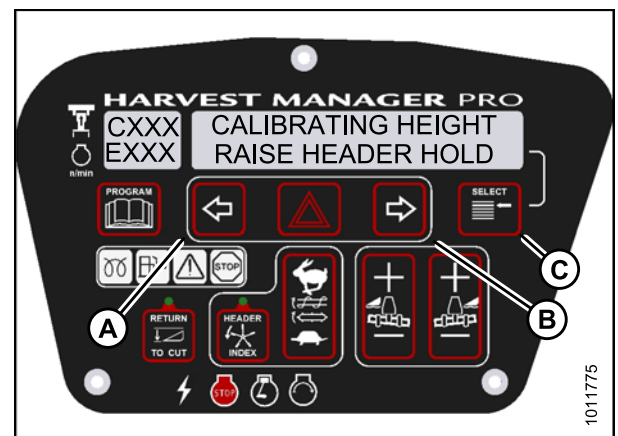

Figure 4.18: Header Height Calibration

⚠ CAUTION

Check to be sure all bystanders have cleared the area.

6. Press and hold the HEADER UP (C) button on the ground speed lever (GSL).
 - CALIBRATING HEIGHT is displayed on the upper line.
 - RAISE HEADER HOLD is displayed on the lower line.

NOTE:

The word HOLD will flash during calibration. RAISE HEADER DONE will display on the lower line once calibration is complete.

7. Release the HEADER UP (C) button.
 - HEIGHT SENSOR CAL is displayed on the upper line.
 - PRESS LOWER HEADER is displayed on the lower line.

8. Press and hold HEADER DOWN (A) button on GSL.

NOTE:

The word HOLD will flash during calibration. HT SENSOR COMPLETE will display on the lower line once calibration is complete.

9. Release HEADER DOWN (A) button.
 - TO CALIBRATE SELECT is displayed on the upper line.
 - HEADER HEIGHT is displayed on the lower line.

10. Press right arrow to select next header sensor calibration or STOP & EXIT. Press SELECT. Refer to [4.3.2 Calibrating the Header Tilt Sensor, page 77](#) or [4.3.3 Calibrating the Header Float Sensors, page 79](#).

11. Press PROGRAM to exit Programming Mode.

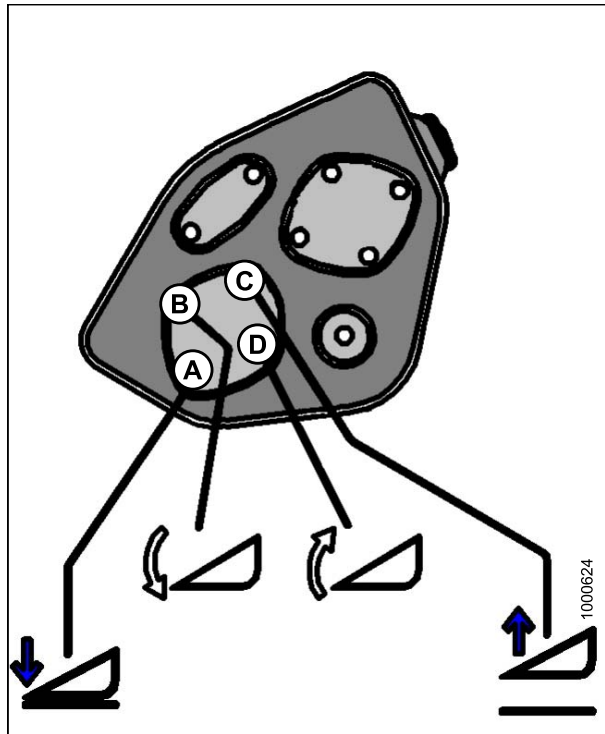

Figure 4.19: Header Height Controls on Ground Speed Lever

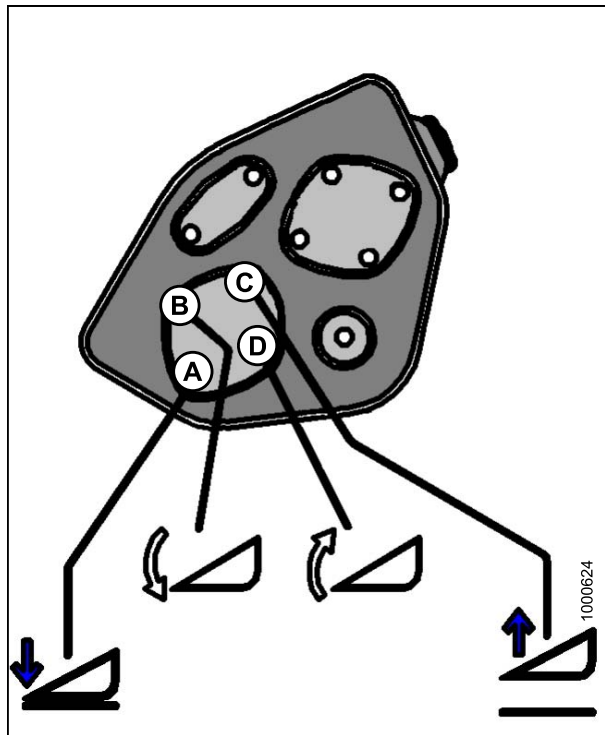

Figure 4.20: Header Height Controls on Ground Speed Lever

CAB DISPLAY MODULE (CDM)

4.3.2 Calibrating the Header Tilt Sensor

NOTE:

- The header **MUST** be attached to the windrower to perform this procedure. The cab display module (CDM) automatically adjusts its programming for each header.
- The engine **MUST** be running to perform this procedure.

1. Turn ignition key to RUN, or start the engine.
2. Press PROGRAM (A) and SELECT (C) on cab display module (CDM) to enter Programming Mode.
 - WINDROWER SETUP? is displayed on the upper line.
3. Press SELECT (C) until CALIBRATE SENSORS? is displayed on the upper line.
 - NO/YES is displayed on the lower line.

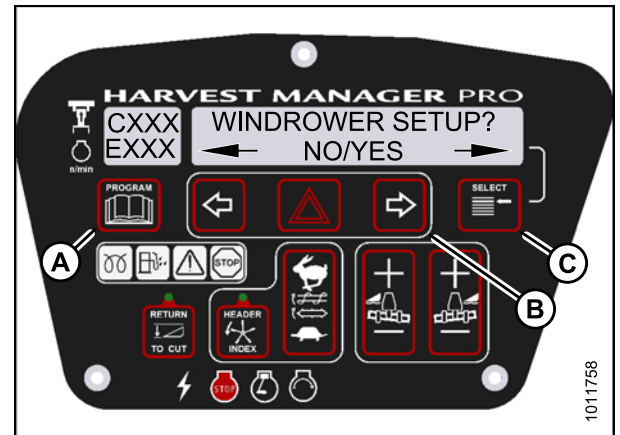

Figure 4.21: CDM Programming Buttons

4. Press right (B) arrow to select YES. Press SELECT (C).
 - TO CALIBRATE SELECT is displayed in upper line.
5. Press left (A) or right (B) arrow until HEADER TILT is displayed on the lower line. Press SELECT (C).
 - HDR TILT SENSOR CAL is displayed on the upper line.
 - EXTEND TILT TO START is displayed on the lower line.



Figure 4.22: Header Tilt

CAUTION

Check to be sure all bystanders have cleared the area.

6. Press and hold the HEADER TILT EXTEND (B) button on the ground speed lever (GSL).
 - CALIBRATING TILT is displayed on the upper line.
 - EXTEND TILT HOLD is displayed on the lower line.

NOTE:

The word HOLD will flash during calibration. HEADER TILT DONE will display on the lower line once calibration is complete.

7. Release the HEADER TILT EXTEND (B) button.
 - HEADER TILT SENSOR CAL is displayed on upper line.
 - PRESS RETRACT TILT is displayed on the lower line.

8. Press and hold HEADER TILT RETRACT (D) button on GSL.
 - CALIBRATING TILT is displayed on the upper line.
 - RETRACT TILT HOLD is displayed on the lower line.

NOTE:

The word HOLD will flash during calibration. HEADER TILT COMPLETE will display on the lower line once calibration is complete.

9. Release HEADER TILT RETRACT (D) button.
 - TO CALIBRATE SELECT is displayed on the upper line.
 - HEADER TILT is displayed on the lower line.
10. Press right arrow to select next header sensor calibration or STOP & EXIT. Press SELECT. Refer to [4.3.1 Calibrating the Header Height Sensor, page 75](#) or [4.3.3 Calibrating the Header Float Sensors, page 79](#).
11. Press PROGRAM to exit Programming Mode.

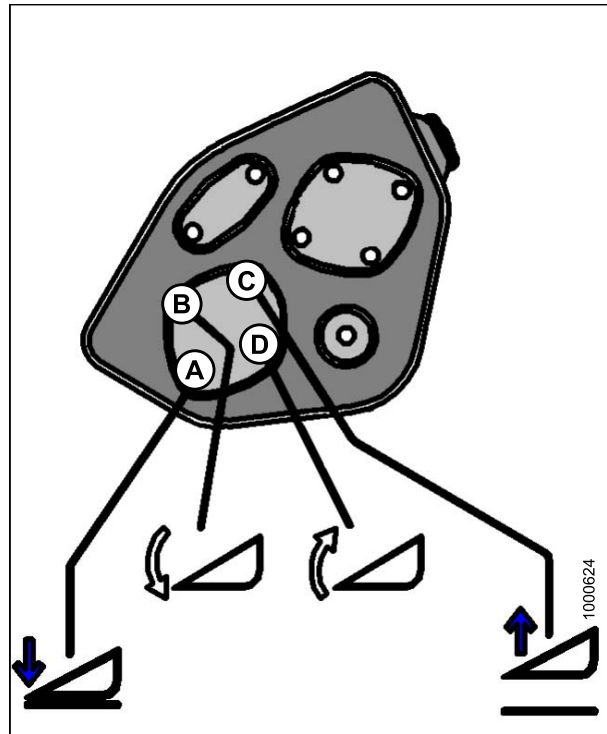

Figure 4.23: Header Tilt Controls on Ground Speed Lever

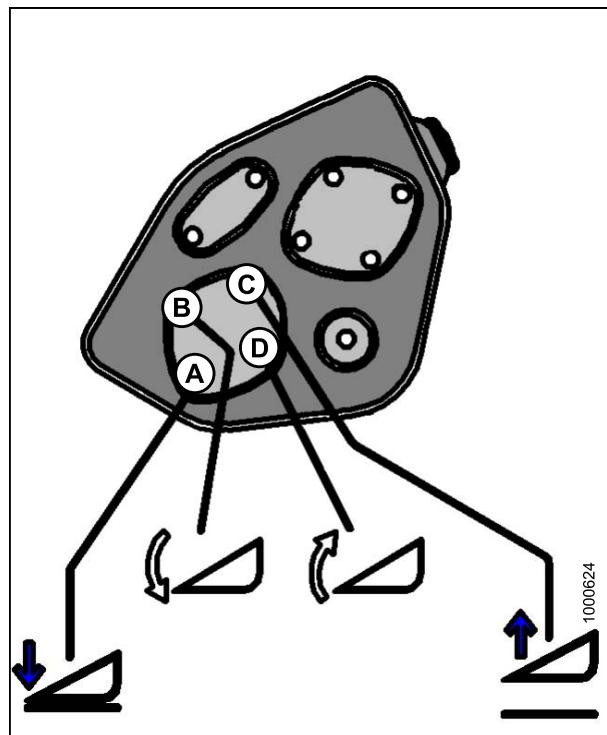

Figure 4.24: Header Tilt Controls on Ground Speed Lever

CAB DISPLAY MODULE (CDM)

4.3.3 Calibrating the Header Float Sensors

NOTE:

- The header **MUST** be attached to the windrower to perform this procedure. The cab display module (CDM) automatically adjusts its programming for each header.
- The Operator can use the left or right FLOAT buttons on the cab display module (CDM) to perform this procedure.

1. Turn ignition key to RUN, or start the engine.
2. Press PROGRAM (A) and SELECT (C) on cab display module (CDM) to enter Programming Mode.
 - WINDROWER SETUP? is displayed on the upper line.
3. Press SELECT (C) until CALIBRATE SENSORS? is displayed on the upper line.
 - NO/YES is displayed on the lower line.

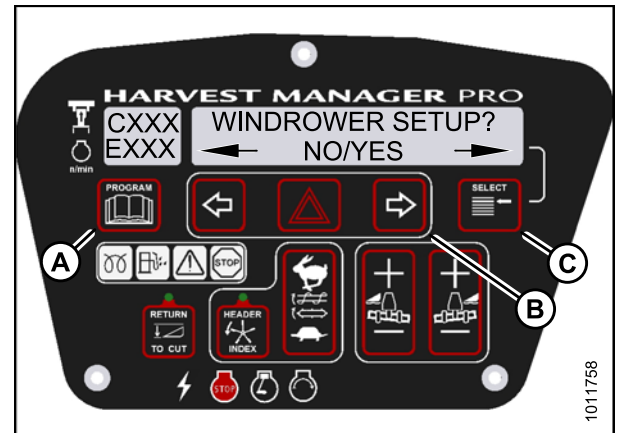

Figure 4.25: CDM Programming Buttons

4. Press right (B) arrow to select Yes. Press SELECT (C).
 - TO CALIBRATE SELECT is displayed in upper line.
5. Press left (A) or right (B) arrow until HEADER FLOAT is displayed on the lower line. Press SELECT (C).
 - CALIBRATING FLOAT is displayed on the upper line.
 - PRESS FLOAT + TO START is displayed on the lower line.

CAUTION

Check to be sure all bystanders have cleared the area.

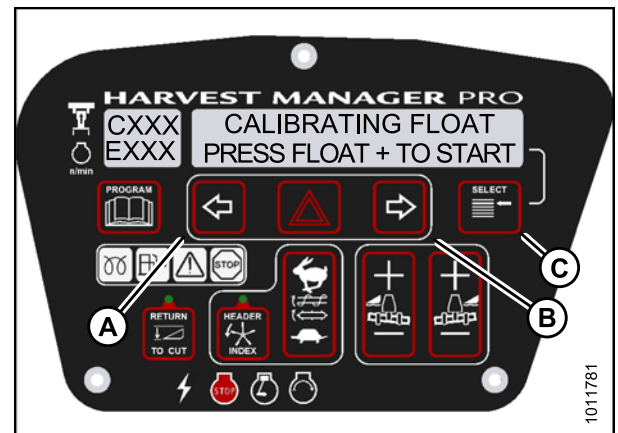

Figure 4.26: Header Float

CAB DISPLAY MODULE (CDM)

6. Press and hold FLOAT + button (A) on the CDM.
 - CALIBRATING FLOAT is displayed on the upper line.
 - FLOAT (+) HOLD is displayed on the lower line.

NOTE:

The word HOLD will flash during calibration.
 FLOAT (+) DONE will display on the lower line once calibration is complete.

7. Release the FLOAT + button (A).
 - CALIBRATING FLOAT is displayed on the upper line.
 - FLOAT (-) HOLD is displayed on the lower line.

8. Press and hold FLOAT - button (A) on CDM.
 - CALIBRATING FLOAT is displayed on the upper line.
 - FLOAT (-) HOLD is displayed on the lower line.

NOTE:

The word HOLD will flash during calibration.
 HDR FLOAT COMPLETE will display on the lower line once calibration is complete.

9. Release FLOAT - button (A).
 - TO CALIBRATE SELECT is displayed on the upper line.
 - HEADER FLOAT is displayed on the lower line.

10. Press right arrow to select next header sensor calibration or STOP & EXIT. Press SELECT
 Refer to [4.3.1 Calibrating the Header Height Sensor, page 75](#) or [4.3.2 Calibrating the Header Tilt Sensor, page 77](#).

11. Press PROGRAM to exit Programming Mode.



Figure 4.27: Positive Header Float

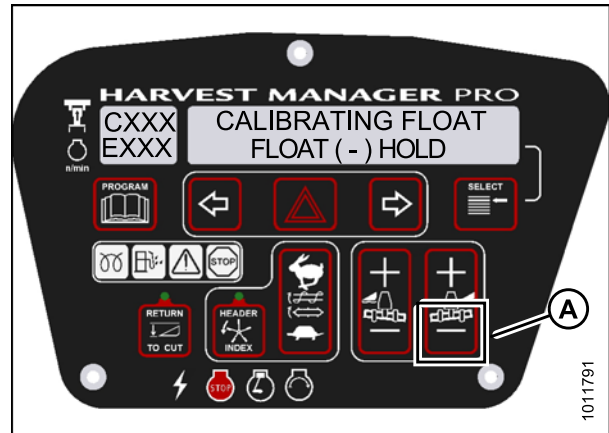

Figure 4.28: Negative Header Float

4.4 Programming the Windrower

The windrower can be programmed to meet changing crop conditions, activate newly added options, indicate a change of header type, or increase your comfort level.

4.4.1 Activating the Hydraulic Center-Link

1. Turn ignition key to RUN, or start the engine. Refer to [3.6 Starting Engine, page 19](#).
2. Press PROGRAM (A) and SELECT (C) on cab display module (CDM) to enter Programming Mode.
 - WINDROWER SETUP? is displayed on the upper line.
 - NO/YES is displayed on the lower line.
3. Press right (B) arrow to select YES. Press SELECT (C).
 - SET KNIFE SPEED? is displayed on the upper line.

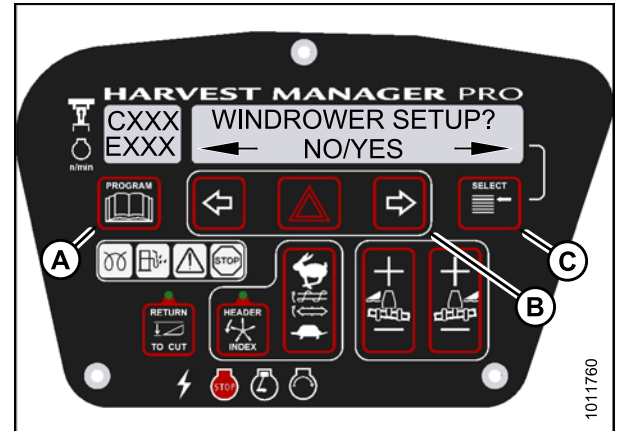

Figure 4.29: CDM Programming Buttons

4. Press SELECT (C) until TILT CYL INSTALLED? is displayed on the upper line.
 - NO/YES is displayed on the lower line.
5. Press right (B) arrow to select YES. Press SELECT (C).
6. Press PROGRAM (A) to exit Programming Mode or press SELECT (C) to proceed to next WINDROWER SETUP action.

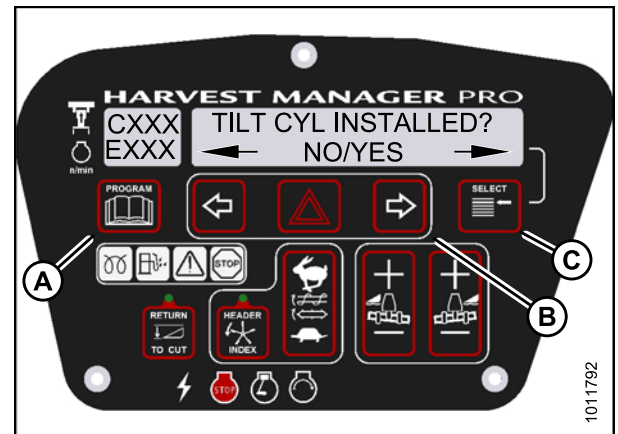

Figure 4.30: Hydraulic Center-Link

4.4.2 Activating the Rotary Header Drive Hydraulics

NOTE:

This procedure requires installation of the optional Rotary Header Drive Hydraulics (MD #B5510). For more information, refer to the rotary disc header operator's manual.

CAB DISPLAY MODULE (CDM)

1. Turn ignition key to RUN, or start the engine. Refer to [3.6 Starting Engine, page 19](#).
2. Press PROGRAM (A) and SELECT (C) on cab display module (CDM) to enter Programming Mode.
 - WINDROWER SETUP? is displayed on the upper line.
 - NO/YES is displayed on the lower line.
3. Press right (B) arrow to select YES. Press SELECT (C).
 - SET KNIFE SPEED? is displayed on the upper line.

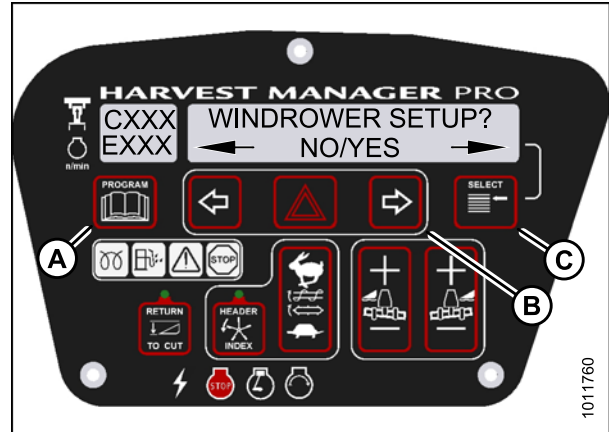

Figure 4.31: CDM Programming Buttons

4. Press SELECT (C) until DISC BLK INSTALLED? is displayed on the upper line.
 - NO/YES is displayed on the lower line.
5. Press right (B) arrow to select YES. Press SELECT (C).
6. Press PROGRAM (A) to exit Programming Mode or press SELECT (C) to proceed to next WINDROWER SETUP action.

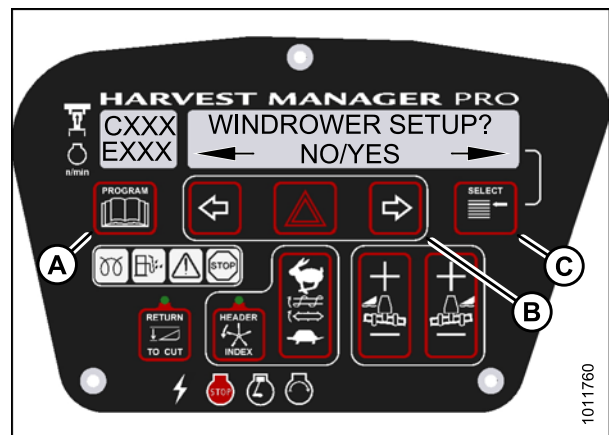

Figure 4.32: Rotary Disc Hydraulics

4.4.3 Setting the Header Knife Speed

NOTE:

The header **MUST** be attached to the windrower to perform this procedure. The cab display module (CDM) automatically adjusts its programming for each header.

1. Turn ignition key to RUN, or start the engine.
2. Press PROGRAM (A) and SELECT (C) on cab display module (CDM) to enter Programming Mode.
 - WINDROWER SETUP? is displayed on the upper line.
 - NO/YES is displayed on the lower line.
3. Press right (B) arrow to select YES. Press SELECT (C).
 - SET KNIFE SPEED? is displayed.
 - The current knife speed is displayed on the lower line.

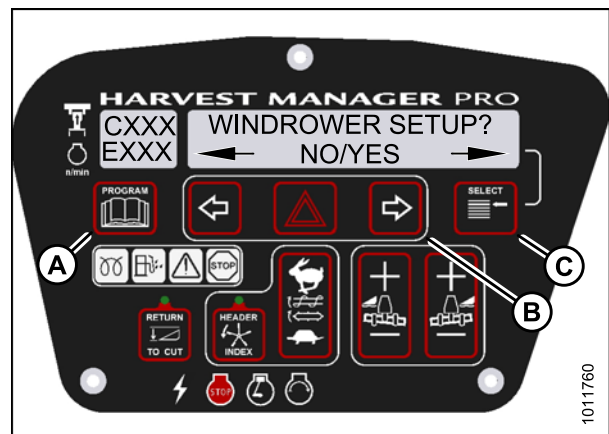

Figure 4.33: CDM Programming Buttons

CAB DISPLAY MODULE (CDM)

4. Press left (B) or right (C) arrows to select knife speed. Press SELECT (D).
5. Press PROGRAM (A) to exit Programming Mode or press SELECT (D) to proceed to next WINDROWER SETUP action.

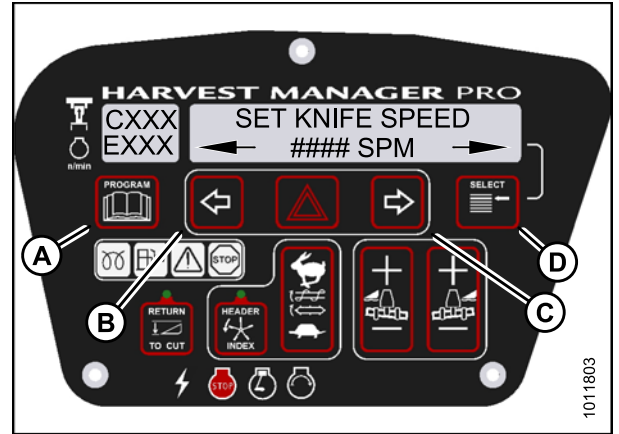

Figure 4.34: Knife Speed

4.4.4 Setting the Knife Overload Speed

NOTE:

- The header **MUST** be attached to the windrower to perform this procedure. The cab display module (CDM) automatically adjusts its programming for each header.
- The recommended knife overload speed is 75% of knife speed.

1. Turn ignition key to RUN, or start the engine.
2. Press PROGRAM (A) and SELECT (C) on cab display module (CDM) to enter Programming Mode.
 - WINDROWER SETUP? is displayed on the upper line.
 - NO/YES is displayed on the lower line.
3. Press right (B) arrow to select YES. Press SELECT (C).
 - SET KNIFE SPEED? is displayed.

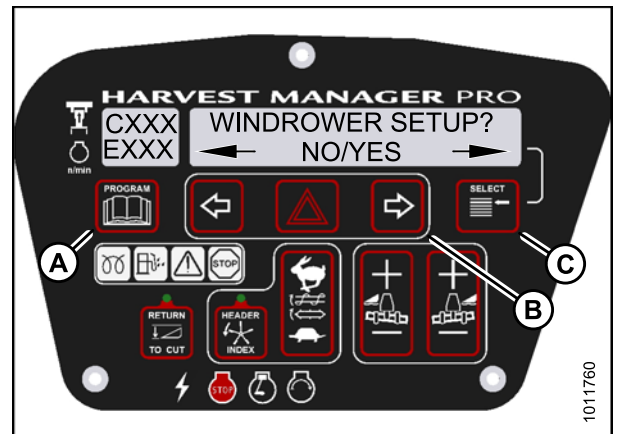

Figure 4.35: CDM Programming Buttons

CAB DISPLAY MODULE (CDM)

4. Press SELECT (D) until KNIFE OVERLOAD SPD? is displayed on the upper line.

- Current overload speed is displayed on the lower line.

NOTE:

Default setting is -300 spm. Range is -500 to -100 spm.

5. Press left (B) or right (C) arrows to set knife overload speed. Press SELECT (D).
6. Press PROGRAM (A) to exit Programming Mode or press SELECT (D) to proceed to next WINDROWER SETUP action.

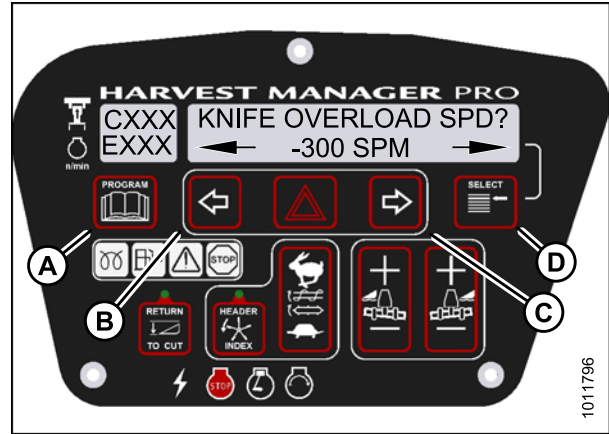

Figure 4.36: Knife Overload Speed

4.4.5 Setting the Rotary Disc Overload Speed

NOTE:

- The header **MUST** be attached to the windrower to perform this procedure. The cab display module (CDM) automatically adjusts its programming for each header.
- The recommended disc overload speed is 75% of disc speed. For more information refer to the rotary disc header operator's manual to determine proper overload speed.

1. Turn ignition key to RUN, or start the engine.
2. Press PROGRAM (A) and SELECT (C) on cab display module (CDM) to enter Programming Mode.
 - WINDROWER SETUP? is displayed on the upper line. NO/YES is displayed on the lower line.
3. Press right (B) arrow to select YES. Press SELECT (C).
 - SET KNIFE SPEED? is displayed.

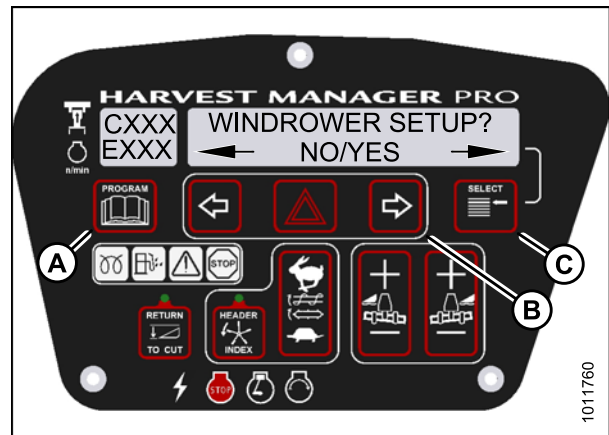

Figure 4.37: CDM Programming Buttons

CAB DISPLAY MODULE (CDM)

4. Press SELECT (D) until DISK OVERLOAD SPD? is displayed on the upper line.

- The current overload speed is displayed on the lower line.

NOTE:

Default setting is -300 rpm. Range is -500 to -100 rpm.

5. Press left (B) or right (C) arrows to set disc overload speed. Press SELECT (D).
6. Press PROGRAM (A) to exit Programming Mode or press SELECT (D) to proceed to next WINDROWER SETUP action.

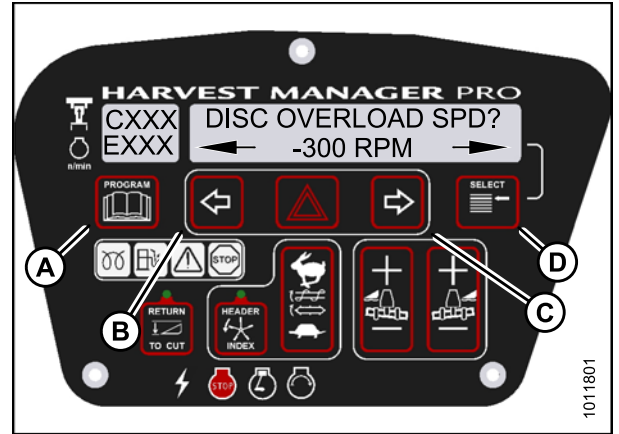

Figure 4.38: Disc Overload Speed

4.4.6 Setting the Hydraulic Overload Pressure

NOTE:

- This procedure requires installation of the optional pressure sensor (MD #B5574). For overload pressure values, refer to pressure sensor installation instructions (MD #169031).
- To enable sensor, refer to [4.7.2 Switching the Installed Header Sensors ON or OFF, page 108](#).

1. Turn ignition key to RUN, or start the engine.
2. Press PROGRAM (A) and SELECT (C) on cab display module (CDM) to enter Programming Mode.
 - WINDROWER SETUP? is displayed on the upper line.
 - NO/YES is displayed on the lower line.
3. Press right (B) arrow to select YES. Press SELECT (C).
 - SET KNIFE SPEED? is displayed.

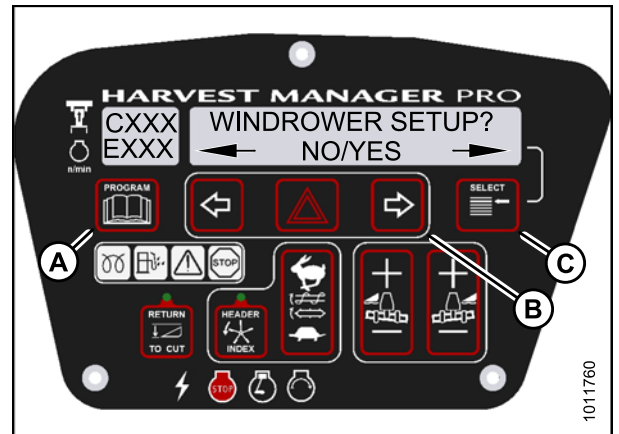

Figure 4.39: CDM Programming Buttons

CAB DISPLAY MODULE (CDM)

4. Press SELECT (D) until OVERLOAD PRESSURE? is displayed on the upper line.

- The current overload pressure is displayed on lower line.

NOTE:

Pressure range is 17,237–34,474 kPa (2500–5000 psi).

5. Press left (B) or right (C) arrows to set hydraulic overload pressure. Press SELECT (D).
6. Press PROGRAM (A) to exit Programming Mode or press SELECT (D) to proceed to next WINDROWER SETUP action.

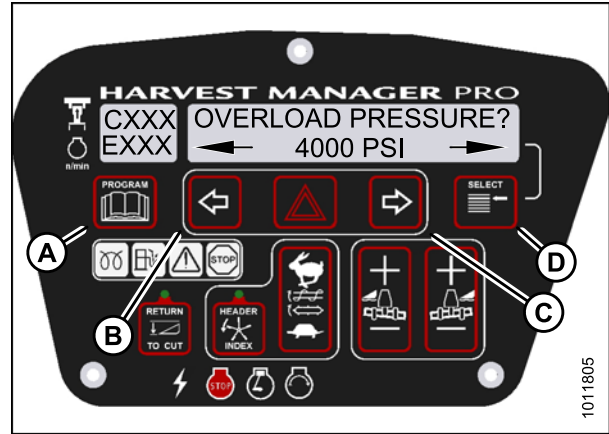

Figure 4.40: Hydraulic Overload Pressure

4.4.7 Setting the Header Index Mode

Header Index feature is not applicable to rotary headers.

NOTE:

The header **MUST** be attached to the windrower to perform this procedure. The cab display module (CDM) automatically adjusts its programming for each header.

1. Turn ignition key to RUN, or start the engine.
2. Press PROGRAM (A) and SELECT (C) on cab display module (CDM) to enter Programming Mode.
 - WINDROWER SETUP? is displayed on the upper line.
 - NO/YES is displayed on the lower line.
3. Press right (B) arrow to select YES. Press SELECT (C).
 - SET KNIFE SPEED? is displayed on the upper line.

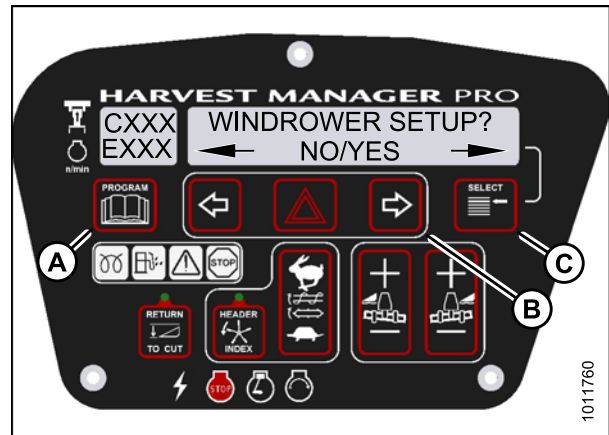

Figure 4.41: CDM Programming Buttons

CAB DISPLAY MODULE (CDM)

4. Press SELECT (D) until HEADER INDEX MODE? is displayed on the upper line.
 - REEL & CONVEYOR or REEL ONLY is displayed on the lower line.
5. Press left (B) or right (C) arrows to set header index mode. Press SELECT (D).
6. Press PROGRAM (A) to exit Programming Mode or press SELECT (D) to proceed to next WINDROWER SETUP action.

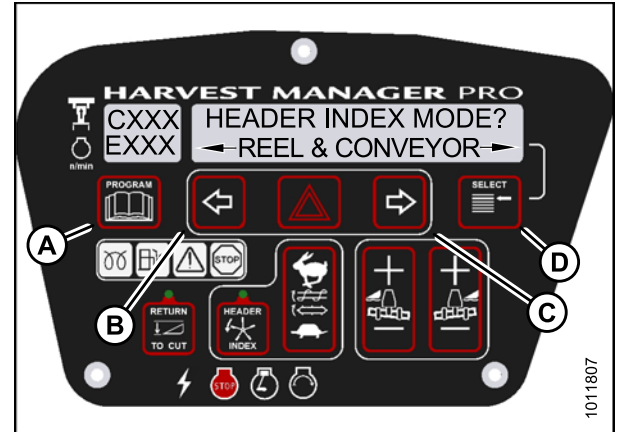

Figure 4.42: Header Index Mode

4.4.8 Setting the Return to Cut Mode

NOTE:

The header **MUST** be attached to the windrower to perform this procedure. The cab display module (CDM) automatically adjusts its programming for each header. For more information, refer to [3.9 Attaching Headers](#), page 27.

1. Turn ignition key to RUN, or start the engine.
2. Press PROGRAM (A) and SELECT (C) on cab display module (CDM) to enter Programming Mode.
 - WINDROWER SETUP? is displayed on the upper line.
 - NO/YES is displayed on the lower line.
3. Press right (B) arrow to select YES. Press SELECT (C).
 - SET KNIFE SPEED? is displayed.

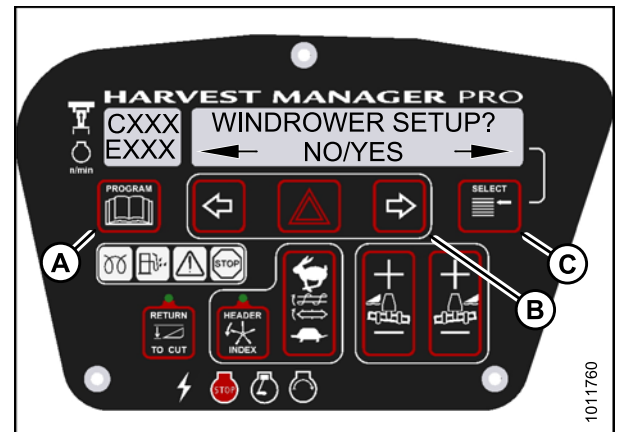

Figure 4.43: CDM Programming Buttons

4. Press SELECT (D) until RETURN TO CUT MODE? is displayed on the upper line.
 - HEIGHT & TILT or HEIGHT ONLY will be displayed on the lower line.
5. Press left (B) or right (C) arrows to select return to cut mode. Press SELECT (D).
6. Press PROGRAM (A) to exit Programming Mode or press SELECT (D) to proceed to next WINDROWER SETUP action.

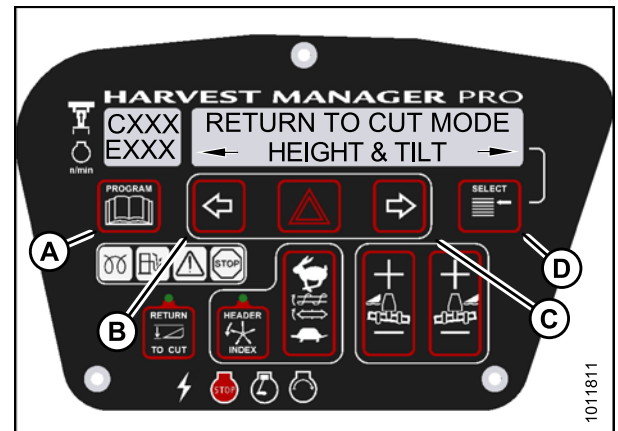

Figure 4.44: Return to Cut Mode

4.4.9 Setting the Header Cut Width

NOTE:

- The header **MUST** be attached to the windrower to perform this procedure. The cab display module (CDM) automatically adjusts its programming for each header.
- Header cut width is less than actual header width to accurately measure number of acres cut.
- The headers sends an electrical signal to the windrower to produce a header ID; however, the cut width will always default to the smallest header size available for each header type. For example, A-Series Auger Headers come in 14-, 16-, and 18-foot sizes, but the cut width will automatically default to the smallest 14-foot size and will need to be changed to your specific header's size.

1. Turn ignition key to RUN, or start the engine.
2. Press PROGRAM (A) and SELECT (C) on cab display module (CDM) to enter Programming Mode.
 - WINDROWER SETUP? is displayed on the upper line.
 - NO/YES is displayed on the lower line.
3. Press right (B) arrow to select YES. Press SELECT (C).
 - SET KNIFE SPEED? is displayed.

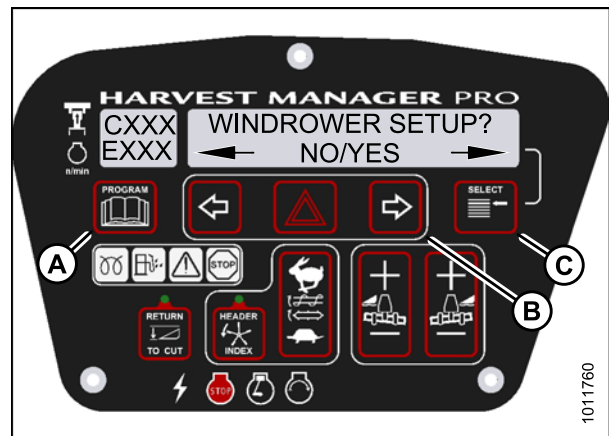

Figure 4.45: CDM Programming Buttons

4. Press SELECT (D) until HDR CUT WIDTH? #### is displayed on the upper line.
 - Previous cutting width is displayed on the lower line.
5. Press left (B) or right (C) arrows to change the headers cut width. Press SELECT (D).
6. Press PROGRAM (A) to exit Programming Mode or press SELECT (D) to proceed to next WINDROWER SETUP action.

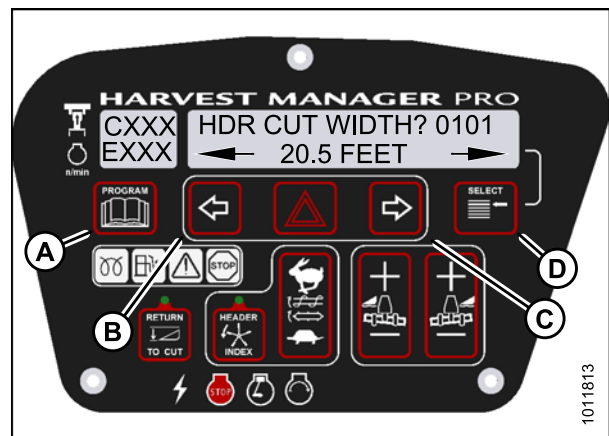

Figure 4.46: Header Cut Width

4.4.10 Activating the Double Windrow Attachment (DWA)

NOTE:

- Follow this procedure if installing the DWA; however, refer to the DWA manual if you require additional installation instructions.
- Follow this procedure if installing a drive manifold (MD #139508).

CAB DISPLAY MODULE (CDM)

1. Turn ignition key to RUN, or start the engine.
2. Press PROGRAM (A) and SELECT (C) on cab display module (CDM) to enter Programming Mode.
 - WINDROWER SETUP? is displayed on the upper line.
 - NO/YES is displayed on the lower line.
3. Press right (B) arrow to select YES. Press SELECT (C).
 - SET KNIFE SPEED? is displayed on the upper line.

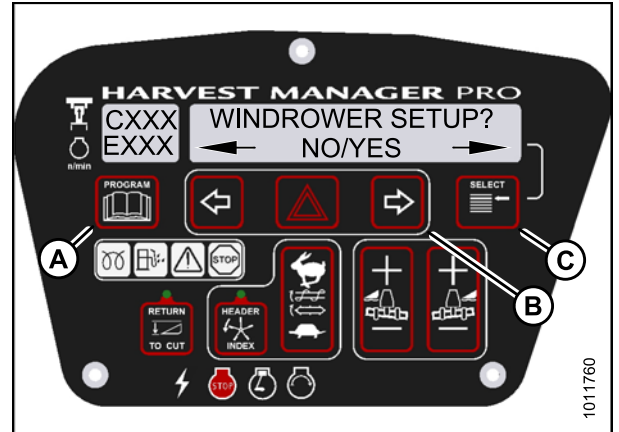

Figure 4.47: CDM Programming Buttons

4. Press SELECT (B) until DWA INSTALLED? is displayed on the upper line.
 - NO/YES is displayed on the lower line.
5. Press right (A) arrow to select YES. Press SELECT (B).

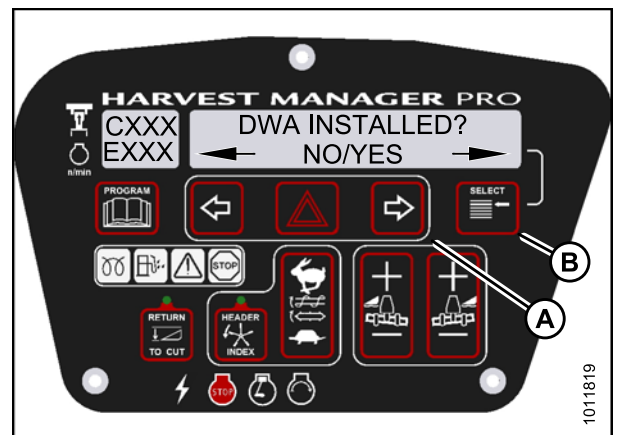

Figure 4.48: DWA Controls

6. SWAP DWA CONTROLS? is displayed on the upper line.
 - NO/YES is displayed on the lower line.

NOTE:

This step swaps the DWA controls from the console switch to the ground speed lever (GSL) reel fore-aft buttons.

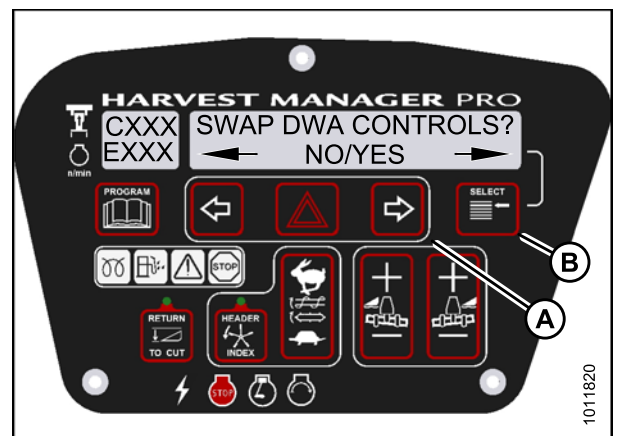

Figure 4.49: DWA Controls

CAB DISPLAY MODULE (CDM)

- Press right (C) arrow to select YES. Press SELECT (D).

 - DWA AUTO UP/DOWN? is displayed on the upper line.
 - NO/YES is displayed on the lower line.

NOTE:

If the Operator selects YES, the DWA Auto-Up function will be activated by the GSL Reel Fore-Aft button.

- Press right (C) arrow to select YES. Press SELECT (D).
- Press PROGRAM to exit Programming Mode or press SELECT to proceed to next WINDROWER SETUP action.

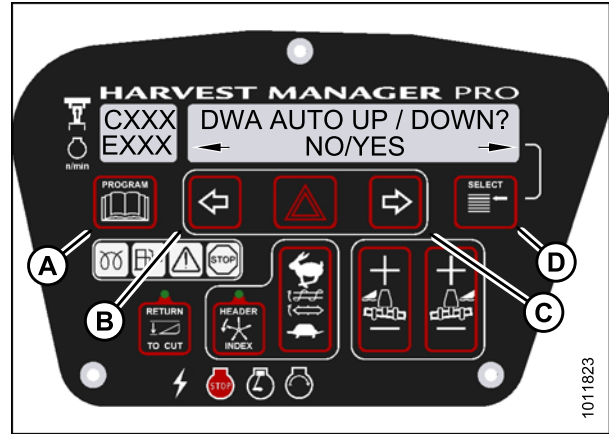

Figure 4.50: DWA Auto Up/Down

4.4.11 Setting the Auto Raise Height

NOTE:

The header **MUST** be attached to the windrower to perform this procedure. The cab display module (CDM) automatically adjusts its programming for each header.

- Turn ignition key to RUN, or start the engine.
- Press PROGRAM (A) and SELECT (C) on cab display module (CDM) to enter Programming Mode.
 - WINDROWER SETUP? is displayed on the upper line.
 - NO/YES is displayed on the lower line.
- Press right (B) arrow to select YES. Press SELECT (C).
 - SET KNIFE SPEED? is displayed on the upper line.

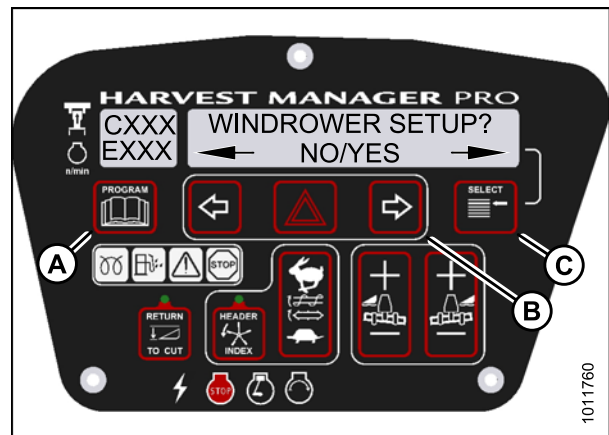

Figure 4.51: CDM Programming Buttons

CAB DISPLAY MODULE (CDM)

4. Press SELECT (D) until AUTO RAISE HEIGHT? is displayed on the upper line.

- Last measurement is displayed on the lower line.

NOTE:

The auto raise height ranges from 4.0 (minimum) to 9.5 (maximum), in 0.5 increments. A setting of 10 disables the auto raise function.

5. Press left (B) arrow or right (C) arrow to change auto-raise height.
6. Press PROGRAM (A) to exit Programming Mode or press SELECT (D) to proceed to next WINDROWER SETUP action.

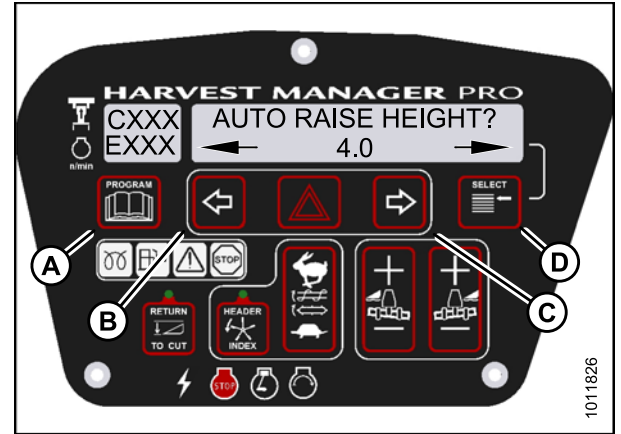

Figure 4.52: Auto Raise Height

4.4.12 Activating the Hay Conditioner

NOTE:

- This procedure is for draper headers only.
- The header **MUST** be attached to the windrower to perform this procedure. The cab display module (CDM) automatically adjusts its programming for each header. For more information, refer to [3.9 Attaching Headers](#), page 27.

1. Turn ignition key to RUN, or start the engine.
2. Press PROGRAM (A) and SELECT (C) on cab display module (CDM) to enter Programming Mode.
 - WINDROWER SETUP? is displayed on the upper line.
 - NO/YES is displayed on the lower line.
3. Press right (B) arrow to select YES. Press SELECT (C).
 - SET KNIFE SPEED? is displayed on the upper line.

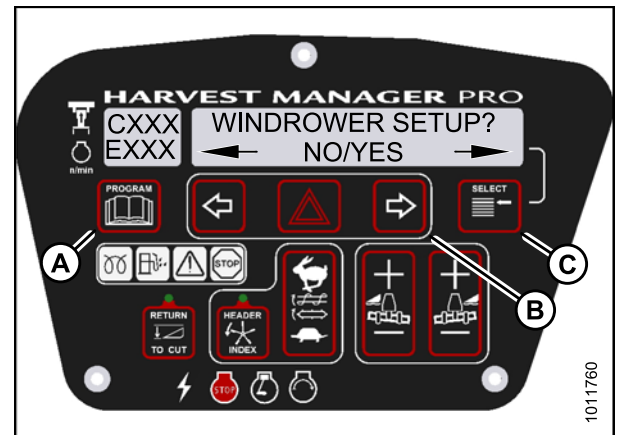

Figure 4.53: CDM Programming Buttons

CAB DISPLAY MODULE (CDM)

4. Press SELECT (C) until HAY CONDITIONER? is displayed on the upper line.
 - NO/YES is displayed on the lower line.
5. Press right (B) arrow to select YES. Press SELECT (C).
6. Press PROGRAM (A) to exit Programming Mode or press SELECT (C) to proceed to next WINDROWER SETUP action.

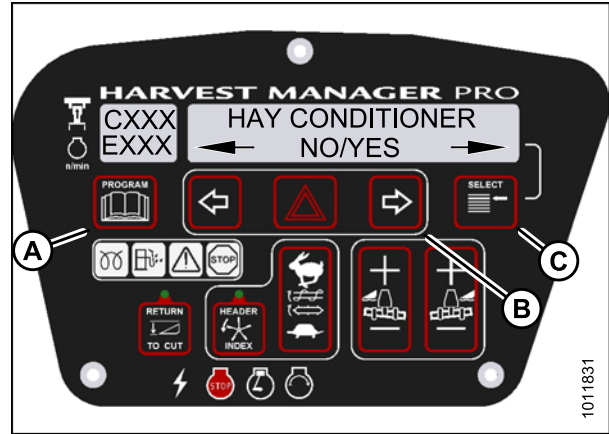

Figure 4.54: Hay Conditioner

4.4.13 Displaying Reel Speed

NOTE:

- This procedure is for draper and auger headers. It does not apply to rotary disc headers.
- The header **MUST** be attached to the windrower to perform this procedure. The cab display module (CDM) automatically adjusts its programming for each header. For more information, refer to [3.9 Attaching Headers](#), page 27.

1. Turn ignition key to RUN, or start the engine.
2. Press PROGRAM (A) and SELECT (C) on CDM to enter Programming Mode.
 - WINDROWER SETUP? is displayed on the upper line.
 - NO/YES is displayed on the lower line.
3. Press right (B) arrow to select YES. Press SELECT (C).
 - SET KNIFE SPEED? is displayed on the upper line.

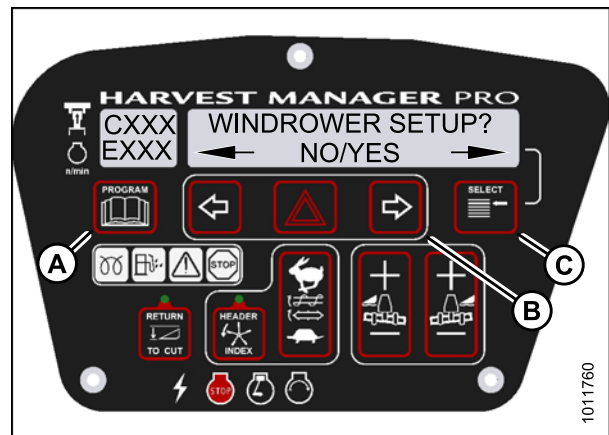

Figure 4.55: CDM Programming Buttons

CAB DISPLAY MODULE (CDM)

4. Press SELECT (D) until HEADER REEL SPEED? is displayed on the upper line.
 - RPM/MPH or RPM/KPH is displayed on the lower line.
5. Press left (B) or right (C) arrow to select either Imperial or Metric units. Press SELECT (D).
6. Press PROGRAM (A) to exit Programming Mode or press SELECT (D) to proceed to next WINDROWER SETUP action.



Figure 4.56: Reel Speed Display

4.4.14 Setting the Windrower's Tire Size

1. Turn ignition key to RUN, or start the engine.
2. Press PROGRAM (A) and SELECT (C) on cab display module (CDM) to enter Programming Mode.
 - WINDROWER SETUP? is displayed on the upper line.
 - NO/YES is displayed on the lower line.
3. Press right (B) arrow to select YES. Press SELECT (C).
 - SET KNIFE SPEED? is displayed on the upper line.

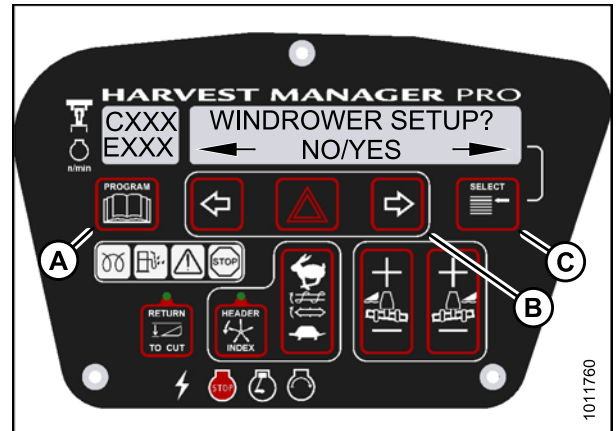

Figure 4.57: CDM Programming Buttons

4. Press SELECT (D) until SET TIRE SIZE? is displayed on the upper line.
 - Currently installed tire size is displayed on the lower line.

NOTE:

The following tire sizes are available:

- 18.4 x 26 TURF
- 18.4 x 26 BAR
- 23.1 x 26 TURF
- 600 – 65 R28

5. Press left (B) or right (C) arrow and select tire size. Press SELECT (D).
6. Press PROGRAM (A) to exit Programming Mode or press SELECT (D) to proceed to next WINDROWER SETUP action.

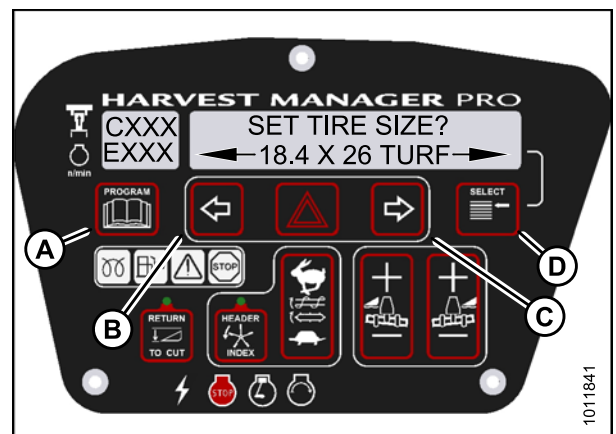

Figure 4.58: Tire Size

4.4.15 Setting the Engine Intermediate Speed Control (ISC) RPM

NOTE:

The engine **MUST** be running to perform this procedure.

1. Turn ignition key to RUN, or start the engine.
2. Press PROGRAM (A) and SELECT (C) on cab display module (CDM) to enter Programming Mode.
 - WINDROWER SETUP? is displayed on the upper line.
 - NO/YES is displayed on the lower line.
3. Press right (B) arrow to select YES. Press SELECT (C).
 - SET KNIFE SPEED? is displayed on the upper line.

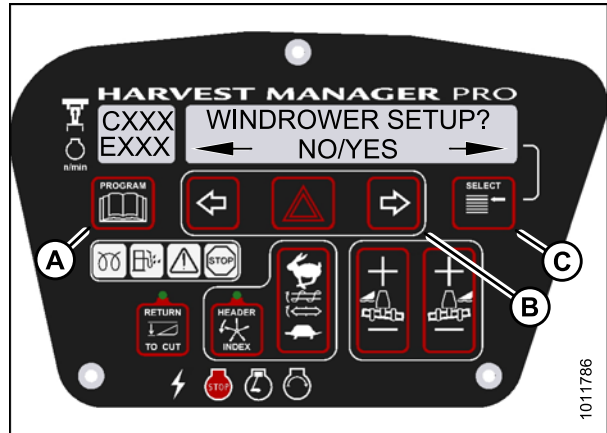

Figure 4.59: CDM Programming Buttons

4. Press SELECT (C) until SET ENGINE ISC RPM? is displayed on the upper line.
 - NO/YES is displayed on the lower line.
5. Press right (B) arrow to select YES. Press SELECT (C).
 - PRESS HAZARD TO SET is displayed on the upper line.
 - ISC RPM #### is displayed on the lower line.

Table 4.1 ISC Settings

ISC and RPM		
Off ⁶	1	2
High Idle	2050	1900

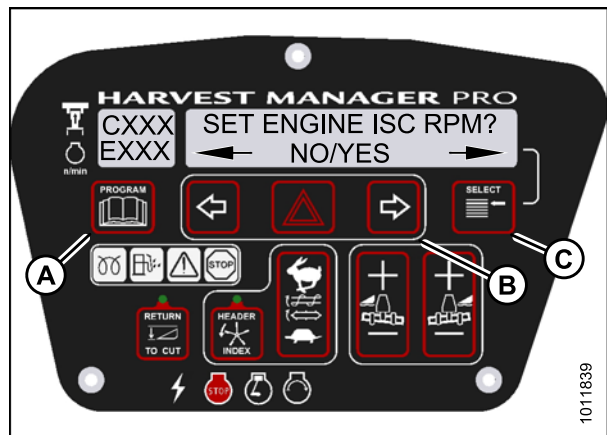

Figure 4.60: Engine ISC RPM

NOTE:

The previously selected ISC rpm will be flashing.

6. Off is always used when the header is not engaged.

CAB DISPLAY MODULE (CDM)

6. Press right (C) arrow to cycle between rpm options. Press HAZARD (B) to set.
7. Press Select (D).
 - EXIT ENGINE ISC? is displayed on the upper line.
 - NO/YES is displayed on the lower line.
8. Press right (C) arrow to select YES. Press SELECT (D).
9. Press PROGRAM (A) to exit Programming Mode.

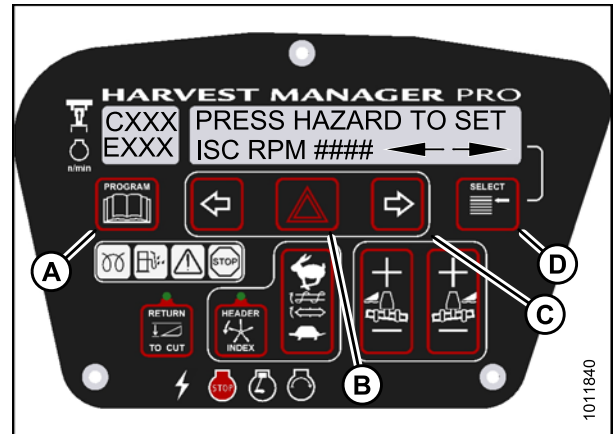

Figure 4.61: ISC RPM

4.4.16 Clearing Sub-Acres

1. With the key in the ON position, and the operator's station in cab-forward mode, press SELECT until the cab display module (CDM) displays sub-acres on the bottom line. Then press and hold the PROGRAM (A) button on the CDM until the sub-acres are cleared.



Figure 4.62: Cab Display Module (CDM)

4.5 Activating Cab Display Lockouts

You can lock some of the header functions controlled by the cab display module (CDM) to prevent accidental changes to header settings. You can use this feature to keep header settings constant when several different Operators use the windrower.

NOTE:

FUNCTION LOCKED flashes on CDM when locked header function switch is pressed.

4.5.1 Activating Knife Speed Control Lockout

NOTE:

The header **MUST** be attached to the windrower to perform this procedure. The cab display module (CDM) automatically adjusts its programming for each header.

1. Turn ignition key to RUN, or start the engine.
2. Press PROGRAM (A) and SELECT (C) on cab display module (CDM) to enter Programming Mode.
 - WINDROWER SETUP? is displayed on the upper line.
 - NO/YES is displayed on the lower line.
3. Press right (B) arrow to select YES. Press SELECT (C).
 - SET KNIFE SPEED? is displayed on the upper line.

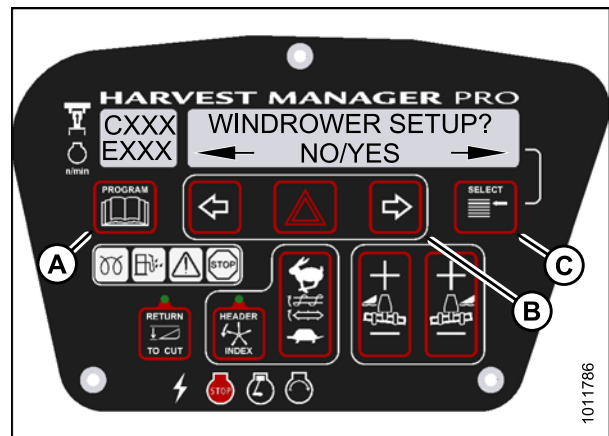

Figure 4.63: CDM Programming Buttons

4. Press SELECT (B) until SET CONTROL LOCKS? is displayed on the upper line.
 - NO/YES is displayed on the lower line.
5. Press right (A) arrow to select YES. Press SELECT (B).

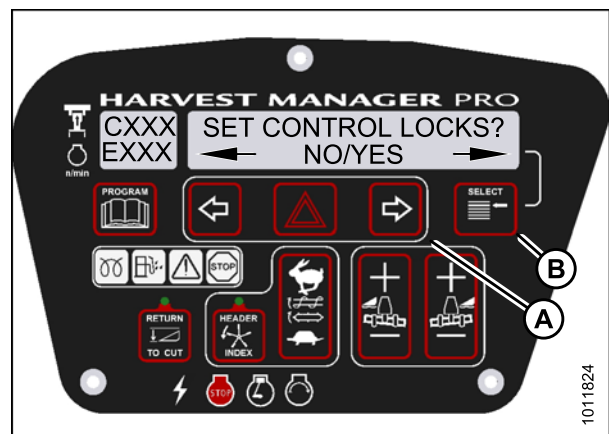

Figure 4.64: Control Locks

CAB DISPLAY MODULE (CDM)

6. Press SELECT (D) until KNIFE SPEED is displayed on the upper line.
 - ENABLED/LOCKED is displayed on the lower line.
7. Press left arrow (B) to enable KNIFE SPEED control switch, or press right arrow (C) to lock KNIFE SPEED control switch.
8. Press PROGRAM (A) to exit Programming Mode or press SELECT (D) to proceed to next WINDROWER SETUP action.

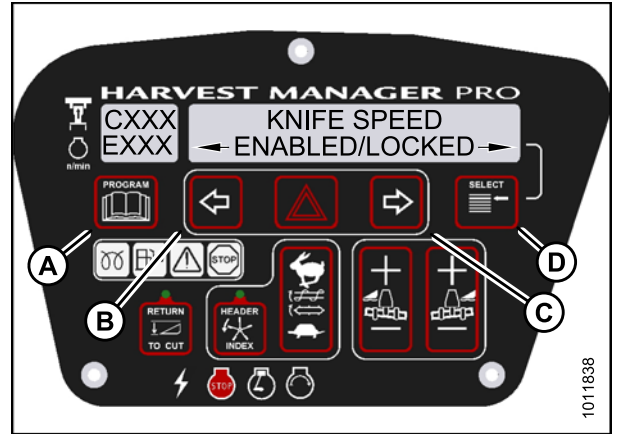

Figure 4.65: Knife Speed Control Lock

4.5.2 Activating Rotary Disc Speed Control Lockout

NOTE:

- This procedure is for rotary disc headers only.
 - The header **MUST** be attached to the windrower to perform this procedure. The cab display module (CDM) automatically adjusts its programming for each header.
1. Turn ignition key to RUN, or start the engine.
 2. Press PROGRAM (A) and SELECT (C) on cab display module (CDM) to enter Programming Mode.
 - WINDROWER SETUP? is displayed on the upper line.
 - NO/YES is displayed on the lower line.
 3. Press right (B) arrow to select YES. Press SELECT (C).
 - SET KNIFE SPEED? is displayed on the upper line.

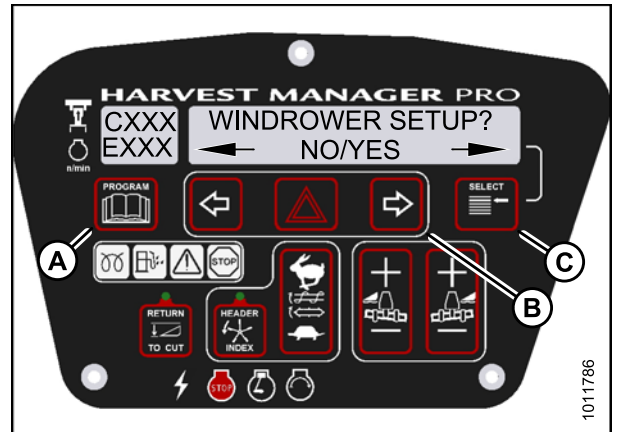

Figure 4.66: CDM Programming Buttons

CAB DISPLAY MODULE (CDM)

- Press SELECT (B) until SET CONTROL LOCKS? is displayed on the upper line.
 - NO/YES is displayed on the lower line.
- Press right (A) arrow to select YES. Press SELECT (B).

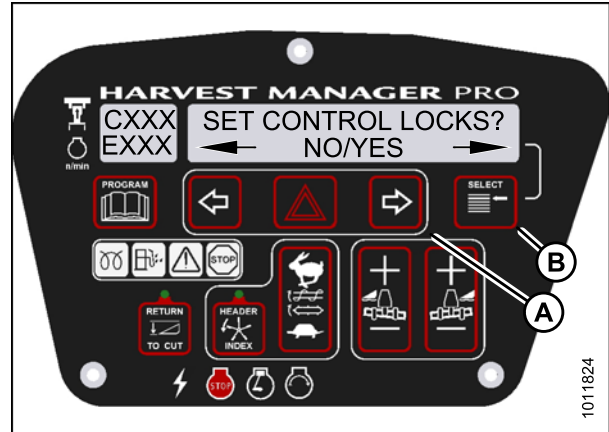

Figure 4.67: Control Locks

- Press SELECT (D) until DISK SPEED is displayed on the upper line.
 - ENABLED/LOCKED is displayed on the lower line.
- Press left arrow (B) to enable DISK SPEED control switch, or press right arrow (C) to lock DISK SPEED control switch.
- Press PROGRAM (A) to exit Programming Mode or press SELECT (D) to proceed to next WINDROWER SETUP action.

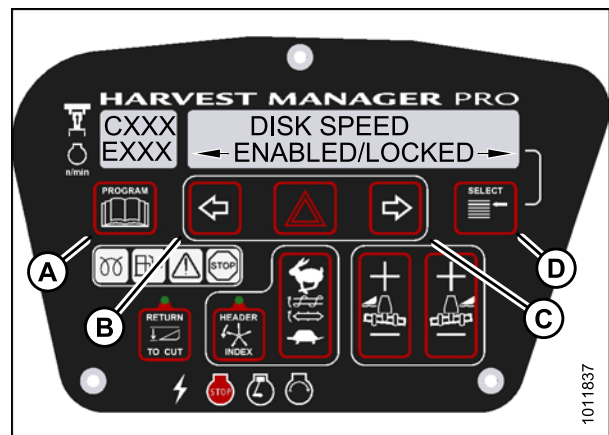

Figure 4.68: Disc Speed Control Lock

4.5.3 Activating the Header Float Control Lockout

NOTE:

The header **MUST** be attached to the windrower to perform this procedure. The cab display module (CDM) automatically adjusts its programming for each header. For more information, refer to [3.9 Attaching Headers](#), page 27.

- Turn ignition key to RUN, or start the engine.
- Press PROGRAM (A) and SELECT (C) on cab display module (CDM) to enter Programming Mode.
 - WINDROWER SETUP? is displayed on the upper line.
 - NO/YES is displayed on the lower line.
- Press right (B) arrow to select YES. Press SELECT (C).
 - SET KNIFE SPEED? is displayed on the upper line.

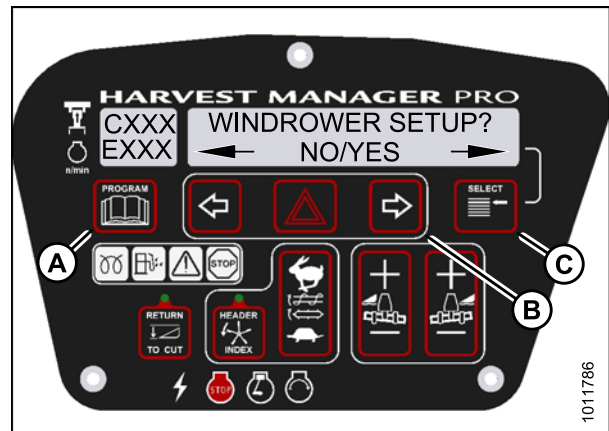

Figure 4.69: CDM Programming Buttons

CAB DISPLAY MODULE (CDM)

4. Press SELECT (B) until SET CONTROL LOCKS? is displayed on the upper line.
 - NO/YES is displayed on the lower line.
5. Press right (A) arrow to select YES. Press SELECT (B).

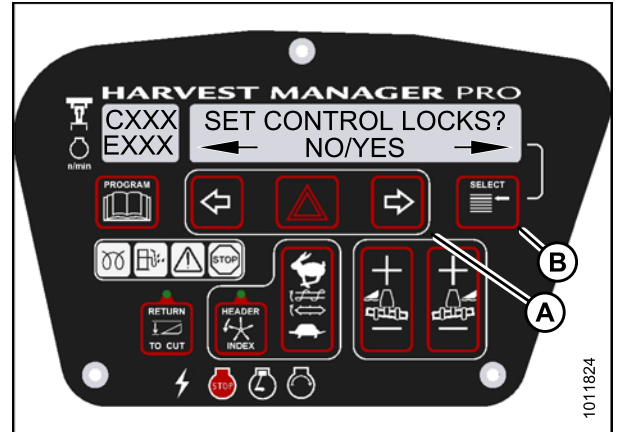

Figure 4.70: Control Locks

6. Press SELECT (D) until HEADER FLOAT is displayed on the upper line.
 - ENABLED/LOCKED is displayed on the lower line.
7. Press left arrow (B) to enable HEADER FLOAT control switch, or press right arrow (C) to lock HEADER FLOAT control switch.
8. Press PROGRAM (A) to exit Programming Mode or press SELECT (D) to proceed to next WINDROWER SETUP action.

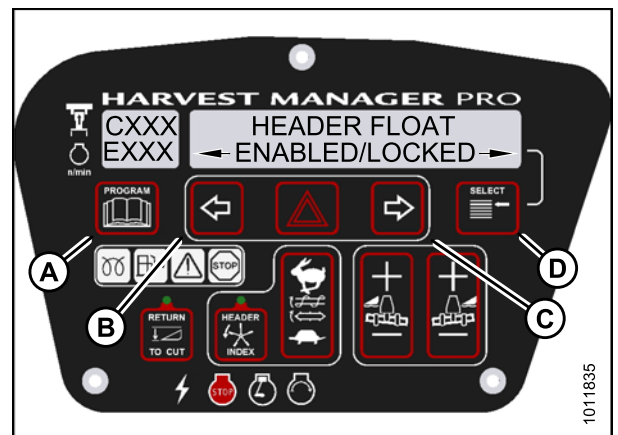

Figure 4.71: Header Float Control Lock

4.5.4 Activating the Draper Speed Control Lockout

NOTE:

- This procedure is for draper headers only.
- The header **MUST** be attached to the windrower to perform this procedure. The cab display module (CDM) automatically adjusts its programming for each header.

CAB DISPLAY MODULE (CDM)

1. Turn ignition key to RUN, or start the engine.
2. Press PROGRAM (A) and SELECT (C) on cab display module (CDM) to enter Programming Mode.
 - WINDROWER SETUP? is displayed on the upper line.
 - NO/YES is displayed on the lower line.
3. Press right (B) arrow to select YES. Press SELECT (C).
 - SET KNIFE SPEED? is displayed on the upper line.

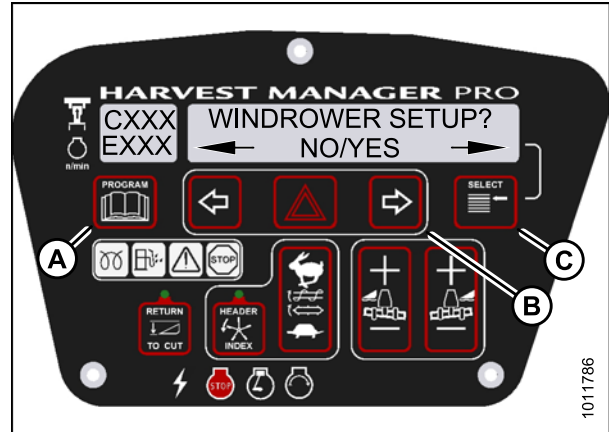

Figure 4.72: CDM Programming Buttons

4. Press SELECT (B) until SET CONTROL LOCKS? is displayed on the upper line.
 - NO/YES is displayed on the lower line.
5. Press right (A) arrow to select YES. Press SELECT (B).



Figure 4.73: Control Locks

6. Press SELECT (D) until DRAPER SPEED is displayed on the upper line.
 - ENABLED/LOCKED is displayed on the lower line.
7. Press left arrow (B) to enable DRAPER SPEED control switch, or press right arrow (C) to lock DRAPER SPEED control switch.
8. Press PROGRAM (A) to exit Programming Mode or press SELECT (D) to proceed to next WINDROWER SETUP action.

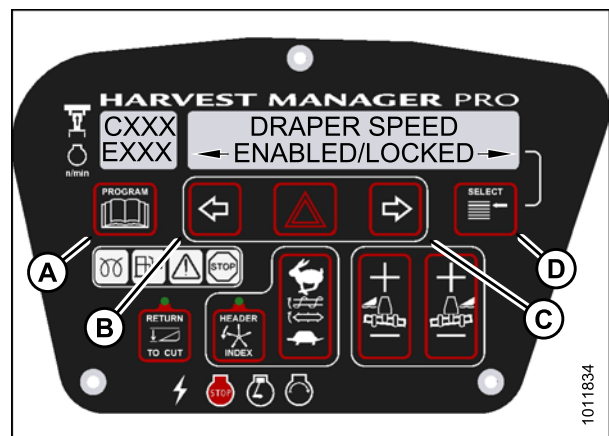

Figure 4.74: Draper Control Lock

CAB DISPLAY MODULE (CDM)

4.5.5 Activating the Auger Speed Control Lockout

NOTE:

- This procedure is for A40-D Headers only.
- An auger header **MUST** be attached to the windrower to perform this procedure. The cab display module (CDM) automatically adjusts its programming for each header.

1. Turn ignition key to RUN, or start the engine.
2. Press PROGRAM (A) and SELECT (C) on cab display module (CDM) to enter Programming Mode.
 - WINDROWER SETUP? is displayed on the upper line.
 - NO/YES is displayed on the lower line.
3. Press right (B) arrow to select YES. Press SELECT (C).
 - SET KNIFE SPEED? is displayed on the upper line.

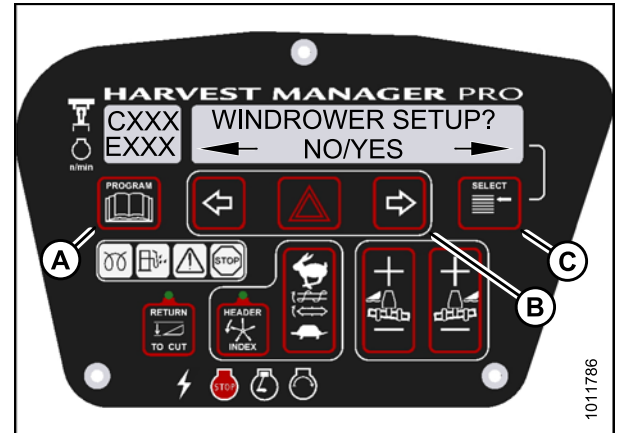

Figure 4.75: CDM Programming Buttons

4. Press SELECT (B) until SET CONTROL LOCKS? is displayed on the upper line.
 - NO/YES is displayed on the lower line.
5. Press right (A) arrow to select YES. Press SELECT (B).

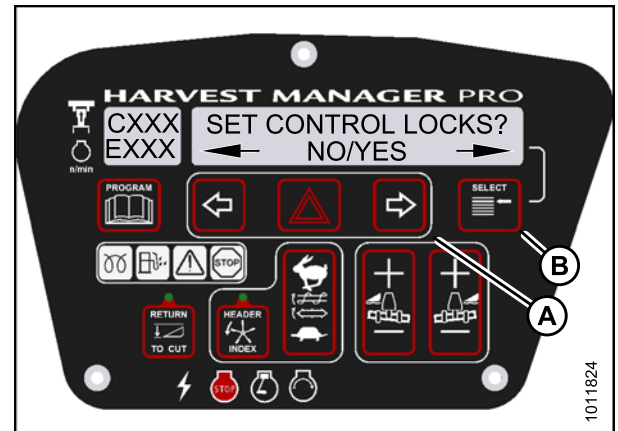

Figure 4.76: Control Locks

6. Press SELECT (D) until AUGER SPEED is displayed on the upper line.
 - ENABLED/LOCKED is displayed on the lower line.
7. Press left (B) arrow to enable AUGER SPEED control switch. Press right (C) arrow to lock AUGER SPEED control switch.
8. Press PROGRAM (A) to exit Programming Mode, or press SELECT (D) to proceed to next WINDROWER SETUP action.

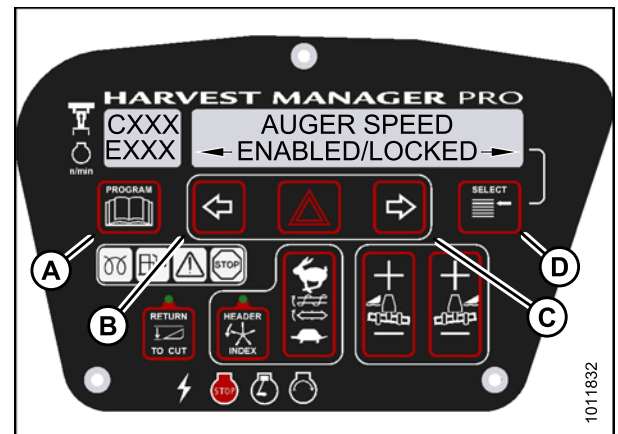

Figure 4.77: Auger Control Lock

CAB DISPLAY MODULE (CDM)

4.5.6 Activating the Reel Speed Control Lockout

NOTE:

The header **MUST** be attached to the windrower to perform this procedure. The cab display module (CDM) automatically adjusts its programming for each header.

1. Turn ignition key to RUN, or start the engine.
2. Press PROGRAM (A) and SELECT (C) on cab display module (CDM) to enter Programming Mode.
 - WINDROWER SETUP? is displayed on the upper line.
 - NO/YES is displayed on the lower line.
3. Press right (B) arrow to select YES. Press SELECT (C).
 - SET KNIFE SPEED? is displayed on the upper line.

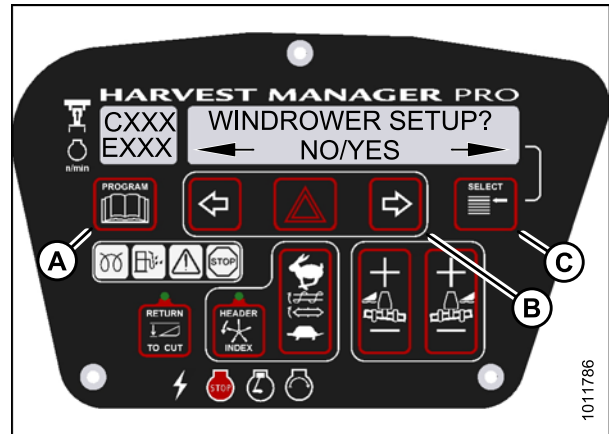

Figure 4.78: CDM Programming Buttons

4. Press SELECT (B) until SET CONTROL LOCKS? is displayed on the upper line.
 - NO/YES is displayed on the lower line.
5. Press right (A) arrow to select YES. Press SELECT (B).

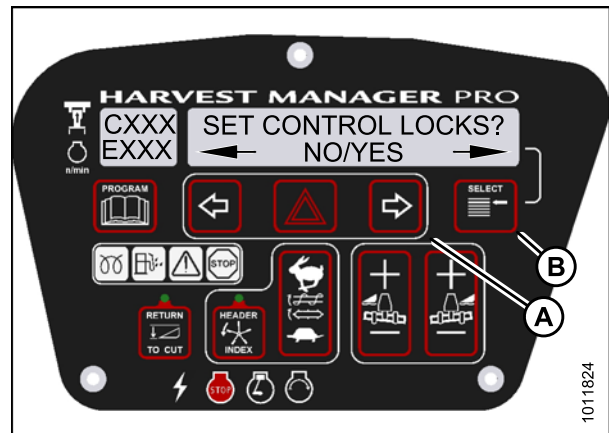

Figure 4.79: Control Locks

6. Press SELECT (D) until REEL SPEED is displayed on the upper line.
 - ENABLED/LOCKED is displayed on the lower line.
7. Press left (B) arrow to enable REEL SPEED control switch. Press right (C) arrow to lock REEL SPEED control switch.
8. Press PROGRAM (A) to exit Programming Mode, or press SELECT (D) to proceed to next WINDROWER SETUP action.

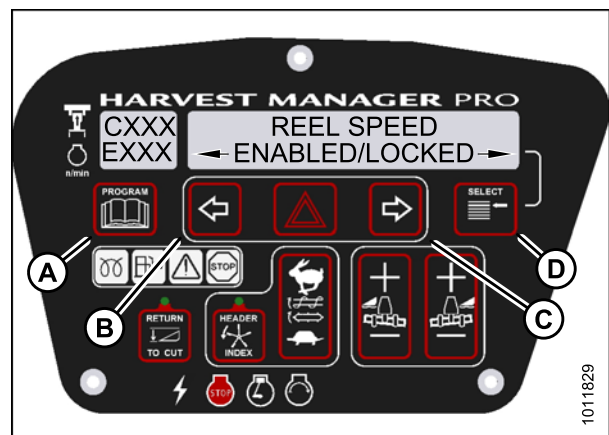

Figure 4.80: Reel Speed Control Lock

CAB DISPLAY MODULE (CDM)

4.5.7 Activating the Reel Fore-Aft Control Lockout

NOTE:

- This procedure is for draper headers only.
- The header **MUST** be attached to the windrower to perform this procedure. The cab display module (CDM) automatically adjusts its programming for each header.

1. Turn ignition key to RUN, or start the engine.
2. Press PROGRAM (A) and SELECT (C) on cab display module (CDM) to enter Programming Mode.
 - WINDROWER SETUP? is displayed on the upper line.
 - NO/YES is displayed on the lower line.
3. Press right (B) arrow to select YES. Press SELECT (C).
 - SET KNIFE SPEED? is displayed on the upper line.

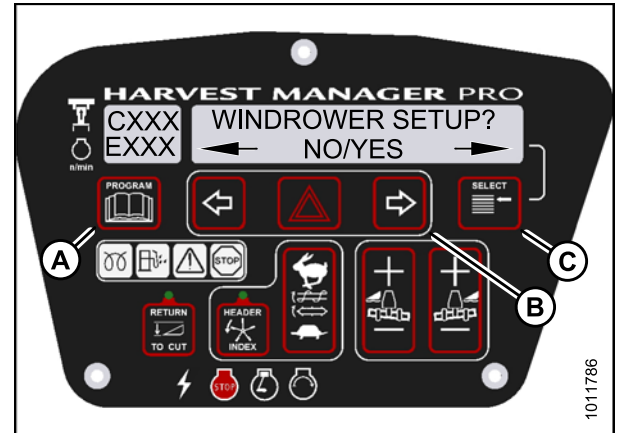

Figure 4.81: CDM Programming Buttons

4. Press SELECT (B) until SET CONTROL LOCKS? is displayed on the upper line.
 - NO/YES is displayed on the lower line.
5. Press right (A) arrow to select YES. Press SELECT (B).

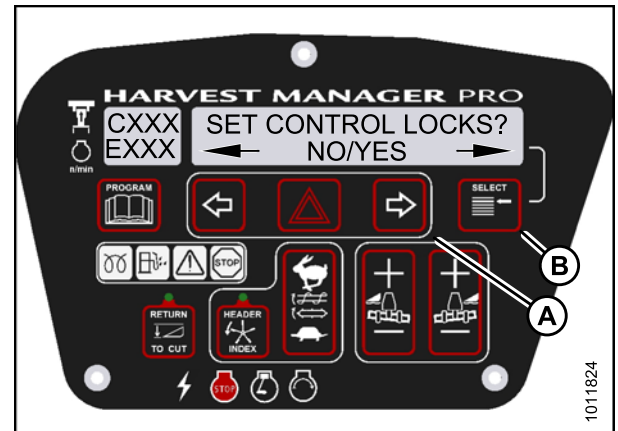

Figure 4.82: Control Locks

6. Press SELECT (D) until REEL FORE/AFT is displayed on the upper line.
 - ENABLED/LOCKED is displayed on the lower line.
7. Press left (B) arrow to enable REEL FORE/AFT control switch. Press right (C) arrow to lock REEL FORE/AFT control switch.
8. Press PROGRAM (A) to exit Programming Mode, or press SELECT (D) to proceed to next WINDROWER SETUP action.

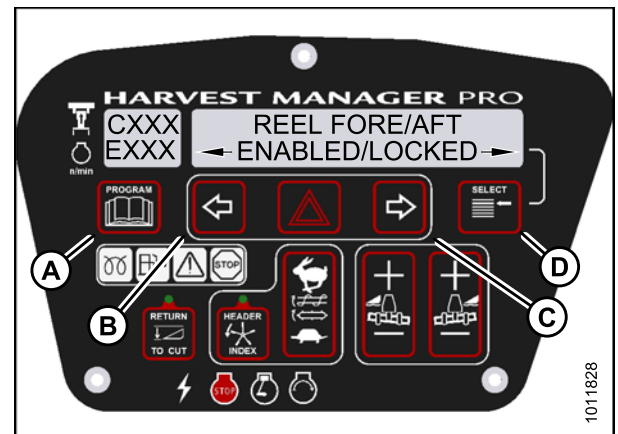

Figure 4.83: Reel Fore-Aft Control Lock

4.5.8 Activating the Header Tilt Control Lockout

NOTE:

- The header **MUST** be attached to the windrower to perform this procedure. The cab display module (CDM) automatically adjusts its programming for each header.

- Turn ignition key to RUN, or start the engine.
- Press PROGRAM (A) and SELECT (C) on cab display module (CDM) to enter Programming Mode.
 - WINDROWER SETUP? is displayed on the upper line.
 - NO/YES is displayed on the lower line.
- Press right (B) arrow to select YES. Press SELECT (C).
 - SET KNIFE SPEED? is displayed on the upper line.

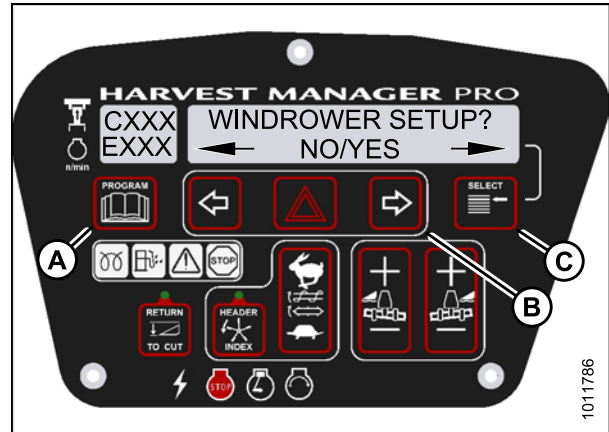

Figure 4.84: CDM Programming Buttons

- Press SELECT (B) until SET CONTROL LOCKS? is displayed on the upper line.
 - NO/YES is displayed on the lower line.
- Press right (A) arrow to select YES. Press SELECT (B).

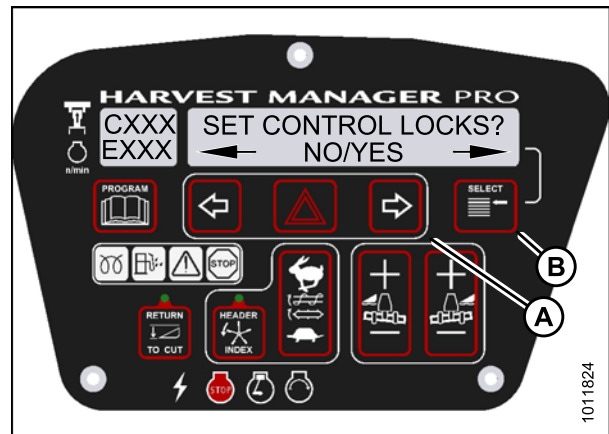

Figure 4.85: Control Locks

- Press SELECT (D) until HEADER TILT is displayed on the upper line.
 - ENABLED/LOCKED is displayed on the lower line.
- Press left (B) arrow to enable HEADER TILT control switch. Press right (C) arrow to lock HEADER TILT control switch.
- Press PROGRAM (A) to exit Programming Mode, or press SELECT (D) to proceed to next WINDROWER SETUP action.

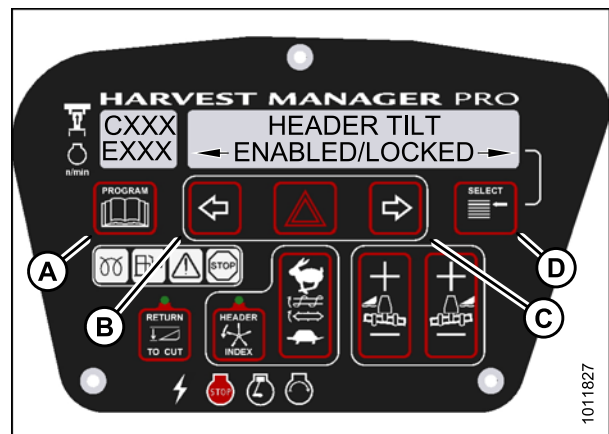

Figure 4.86: Header Tilt Control Lock

4.6 Displaying Activated Cab Display Lockouts

Displaying the activated control locks allows you to quickly determine which controls are locked on the cab display module (CDM).

1. Turn ignition key to RUN, or start the engine.
2. Press PROGRAM (A) and SELECT (C) on cab display module (CDM) to enter Programming Mode.
 - WINDROWER SETUP? is displayed on the upper line.
 - NO/YES is displayed on the lower line.
3. Press right (B) arrow to select YES. Press SELECT (C).
 - SET KNIFE SPEED? is displayed on the upper line.

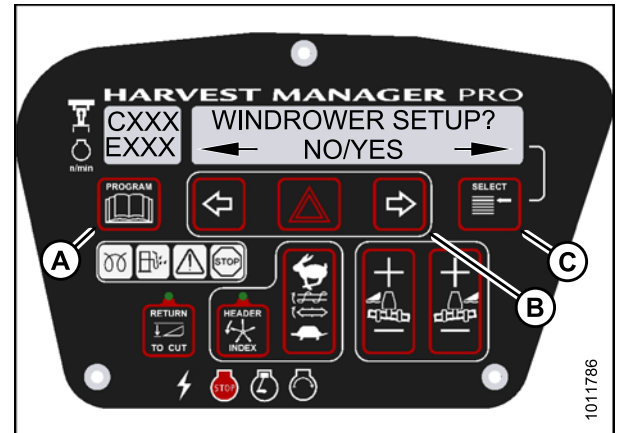

Figure 4.87: CDM Programming Buttons

4. Press SELECT (B) until VIEW CONTROL LOCKS? is displayed on the upper line.
 - NO/YES is displayed on the lower line.
5. Press right (A) arrow to select YES. Press SELECT (B).
 - HEADER TILT is displayed on the upper line.
 - The control switch status is displayed on the lower line. The hours displayed indicate when a switch was enabled or locked.

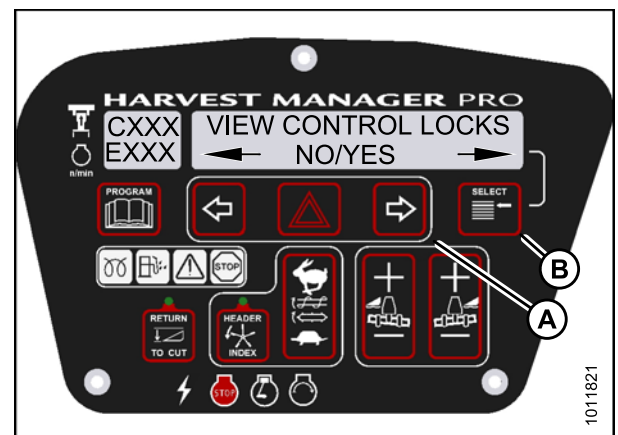

Figure 4.88: Control Locks

CAB DISPLAY MODULE (CDM)

6. Press left (B) or right (C) arrow to cycle between control switch lock outs. The displayed control switches are as follows:
 - HEADER TILT
 - HEADER FLOAT
 - REEL FORE/AFT
 - DRAPER SPEED
 - AUGER SPEED
 - KNIFE SPEED
 - DISK SPEED
 - REEL SPEED

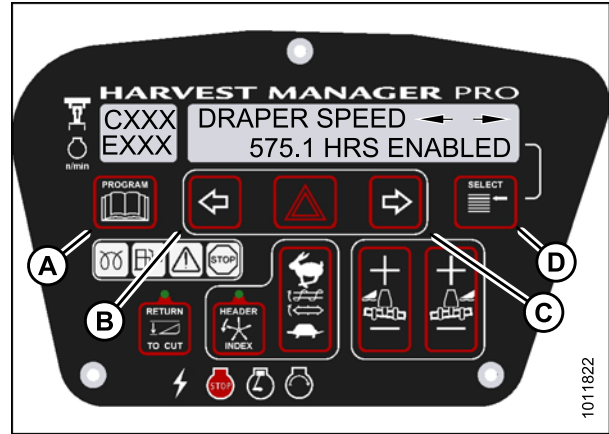

Figure 4.89: Control Locks

NOTE:

Not all control locks apply to every header.

7. Press SELECT.
 - EXIT VIEW LOCKOUTS? is displayed on the upper line.
 - NO/YES is displayed on the lower line.
8. Press right to select YES.
9. Press PROGRAM to exit Programming Mode or press SELECT to proceed to next WINDROWER SETUP action.

4.7 Troubleshooting Windrower Problems

4.7.1 Displaying the Windrower and Engine Error Codes

1. Turn ignition key to RUN, or start the engine.
2. Press PROGRAM (A) and SELECT (C) on cab display module (CDM) to enter Programming Mode. Press SELECT (C).
 - WINDROWER SETUP? is displayed on the upper line.
3. Press SELECT (C) until DIAGNOSTIC MODE? is displayed in upper line.
 - NO/YES is displayed on the lower line.

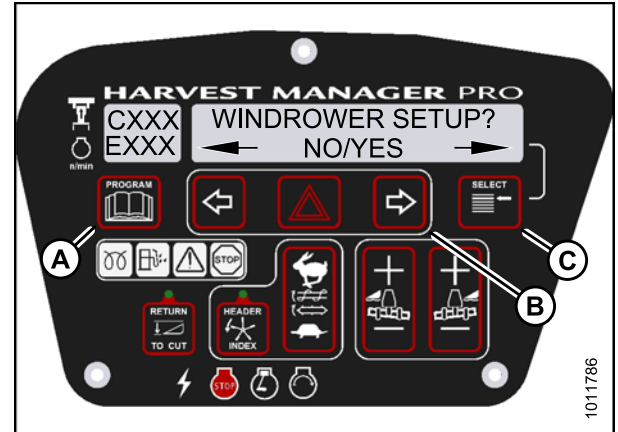

Figure 4.90: CDM Programming Buttons

4. Press right (A) arrow to select Yes. Press SELECT (B).
5. VIEW ERROR CODES? is displayed on the upper line.
 - NO/YES is displayed on the lower line.
6. Press right (A) arrow to select YES. Press SELECT (B).
 - VIEW WINDRWR CODES? is displayed on the upper line.
 - NO/YES is displayed on the lower line.

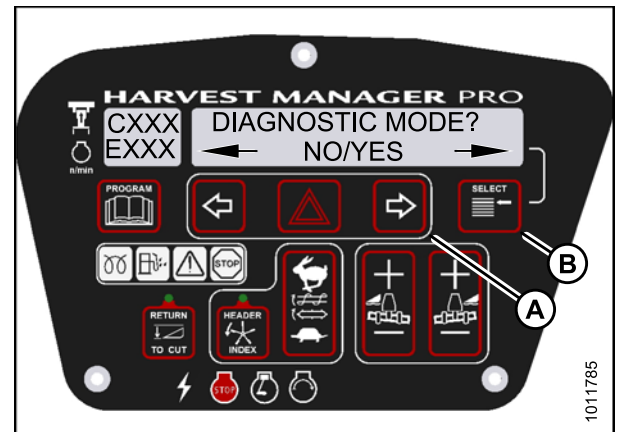

Figure 4.91: Diagnostic Functions

7. Press right (C) arrow to select YES. Press SELECT (D).
8. Press and left (B) or right (C) arrow to cycle through the last ten recorded windrower error codes until EXIT WINDROWER CODES is displayed.
9. Press right (C) arrow to select YES. Press SELECT (D).
 - VIEW ENGINE CODES is displayed on the upper line.
 - NO/YES is displayed on the lower line.

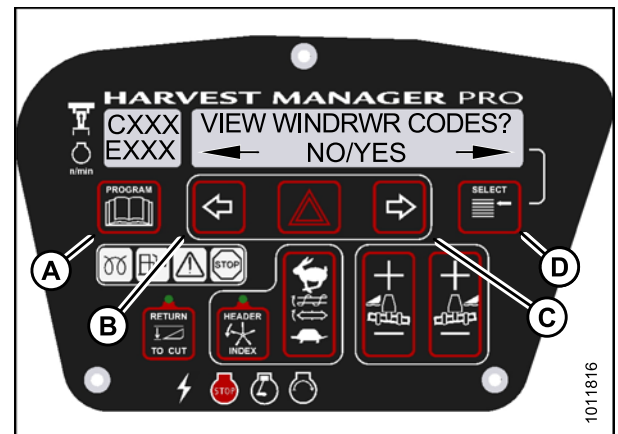

Figure 4.92: Windrower Codes

CAB DISPLAY MODULE (CDM)

10. Press right (C) arrow to select YES. Press SELECT (D).
11. Press left (B) or right (C) arrow to cycle through the last ten recorded engine error codes until EXIT ENGINE CODES is displayed.
12. Press right (C) arrow to select YES. Press SELECT (D).
13. Press PROGRAM (A) to exit Programming Mode or press SELECT (D) to proceed to next DIAGNOSTIC MODE.

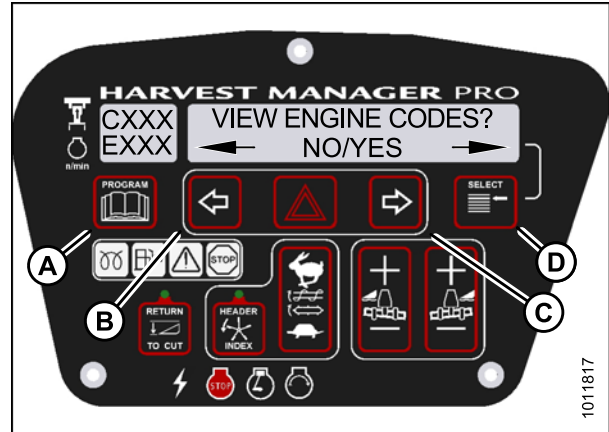

Figure 4.93: Engine Codes

4.7.2 Switching the Installed Header Sensors ON or OFF

You can selectively enable or disable header sensors in the event of a malfunction or as part of a troubleshooting routine.

NOTE:

- The header **MUST** be attached to the windrower to perform this procedure. The cab display module (CDM) automatically adjusts its programming for each header.
- Disabled sensors flash the word SENSOR on CDM during regular operation.

1. Turn ignition key to RUN, or start the engine.
2. Press PROGRAM (A) and SELECT (C) on cab display module (CDM) to enter Programming Mode.
 - WINDROWER SETUP? is displayed on the upper line.
 - NO/YES is displayed on the lower line.
3. Press SELECT (C) until DIAGNOSTIC MODE? is displayed on the upper line.
 - NO/YES is displayed on the lower line.
4. Press right (B) arrow to select YES. Press SELECT (C).
 - VIEW ERROR CODES? is displayed on the upper line.

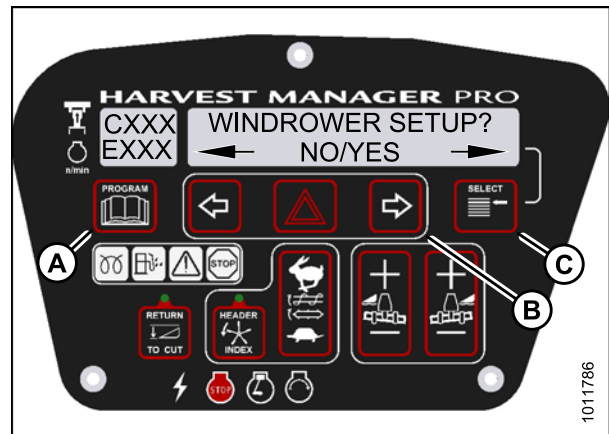

Figure 4.94: CDM Programming Buttons

CAB DISPLAY MODULE (CDM)

5. Press SELECT (B) until ENTER SENSOR SETUP? is displayed on the upper line.
 - NO/YES is displayed on the lower line.
6. Press right (A) arrow to select YES. Press SELECT (B).
 - KNIFE SPEED SENSOR is displayed on the lower line.
 - ENABLE/DISABLE is displayed on the lower line.

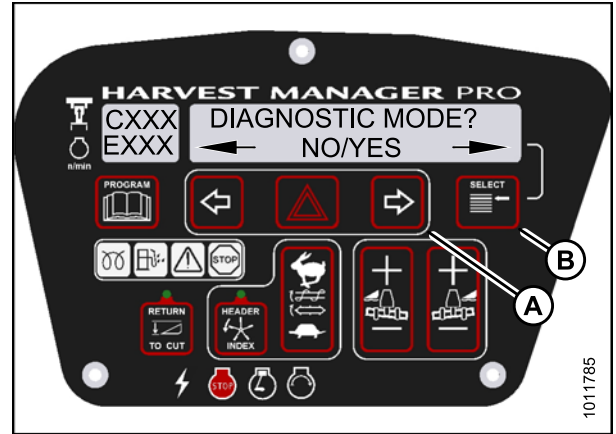

Figure 4.95: Diagnostic Functions

7. Press left (B) arrow to enable a sensor. Press right (C) arrow to disable sensor. Press SELECT (D) to confirm selection and move on to next sensor. The following sensors are available:
 - HEADER HT SENSOR
 - HEADER TILT SENSOR
 - KNIFE SPEED SENSOR
 - REEL SPEED SENSOR
 - HEADER FLOAT SENSOR
 - OVERLOAD PRESSURE⁷
 - HYD OIL TEMP SENSOR

When sensors have been modified, press SELECT (D) to display the EXIT SENSOR SETUP? selection.

8. Press right arrow to select YES. Press SELECT.
9. Press PROGRAM to exit Programming Mode or press SELECT to proceed to next DIAGNOSTIC MODE.



Figure 4.96: Header Sensors

4.7.3 Displaying Header Sensor Input Signals

You can display individual sensor input signals in the event of a malfunction or as part of a troubleshooting routine.

NOTE:

The header **MUST** be attached to the windrower to perform this procedure. The cab display module (CDM) automatically adjusts its programming for each header.

7. Requires installation of optional pressure sensor (MD #B5574).

CAB DISPLAY MODULE (CDM)

1. Turn ignition key to RUN, or start the engine.
2. Press PROGRAM (A) and SELECT (C) on cab display module (CDM) to enter Programming Mode.
 - WINDROWER SETUP? is displayed on the upper line.
 - NO/YES is displayed on the lower line.

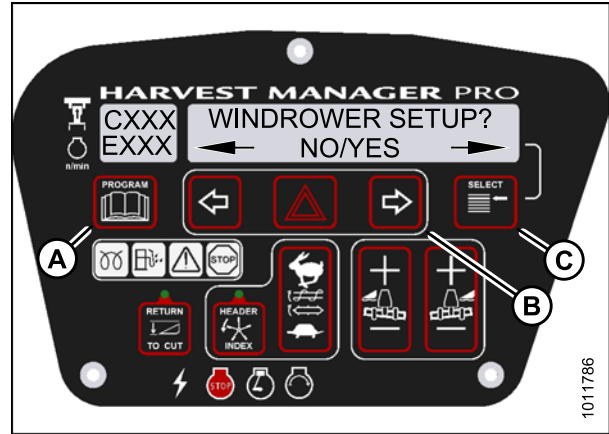

Figure 4.97: CDM Programming Buttons

3. Press SELECT (B) until DIAGNOSTIC MODE? is displayed on the upper line.
 - NO/YES is displayed on the lower line.
4. Press right (A) arrow to select YES. Press SELECT (B).
 - VIEW ERROR CODES? is displayed on the upper line.
5. Press SELECT (B) until READ SENSOR SETUP? is displayed on the upper line.
 - NO/YES is displayed on the lower line.

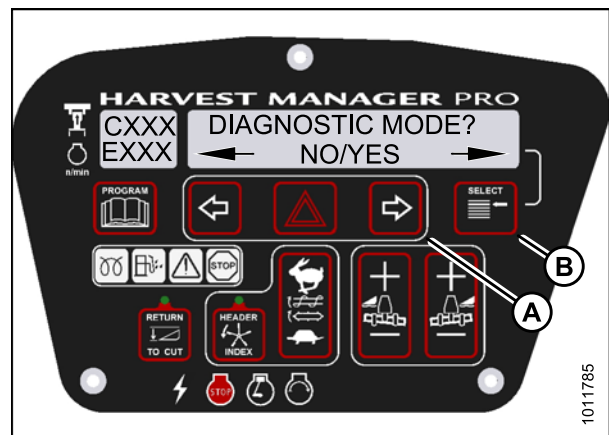

Figure 4.98: Diagnostic Functions

6. Press right (C) arrow to select YES. Press SELECT (D).
 - SENSOR INPUT is displayed on the upper line.
 - HDR HEIGHT 1.23 V is displayed on the lower line.
7. Press left (B) or right (C) arrow to cycle between individual sensor readers.
8. Press SELECT (D) to skip to EXIT READ SENSORS? selection.



Figure 4.99: Header Sensors

9. Press right arrow to select YES. Press SELECT.
10. Press PROGRAM to exit Programming Mode or press SELECT to proceed to next DIAGNOSTIC MODE.

CAB DISPLAY MODULE (CDM)

4.7.4 Forcing a Header ID

The header must be attached to the windrower to troubleshoot certain issues. If damage has occurred to the header wiring or no header is available, you can force the windrower control module (WCM) to read a header ID. The WCM reverts to reading NO HEADER each time the engine ignition is cycled.

IMPORTANT:

Forcing a Header ID that is different from the attached header can damage the windrower and header. Doing so can lead to vibration, belt failures, and other over-speeding related problems.

1. Turn ignition key to RUN, or start the engine.
2. Press PROGRAM (A) and SELECT (C) on cab display module (CDM) to enter Programming Mode.
 - WINDROWER SETUP? is displayed on the upper line.

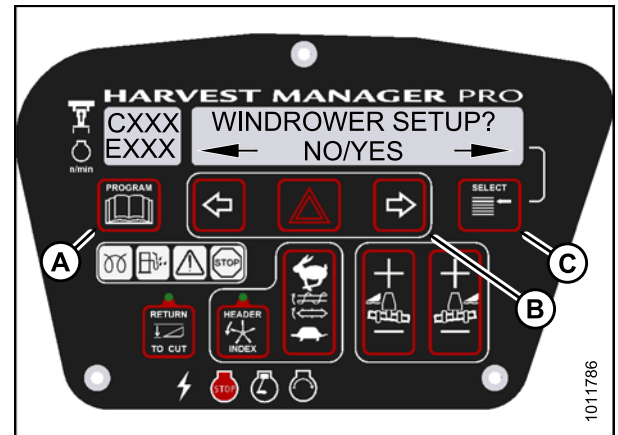

Figure 4.100: CDM Programming Buttons

3. Press SELECT (B) until DIAGNOSTIC MODE? is displayed in upper line.
 - NO/YES is displayed on the lower line.
4. Press right (A) arrow to select YES. Press SELECT (B).

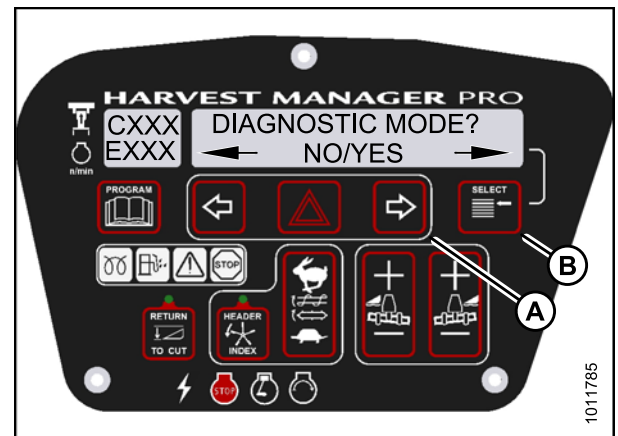

Figure 4.101: Diagnostic Functions

CAB DISPLAY MODULE (CDM)

5. Press SELECT (B) until FORCE HEADER TYPE? is displayed on the upper line.
 - NO/YES is displayed on the lower line.
6. Press right (A) arrow to select YES. Press SELECT (B).
 - SELECT HEADER TYPE is displayed on the upper line.
 - DISK HEADER is displayed on the lower line.

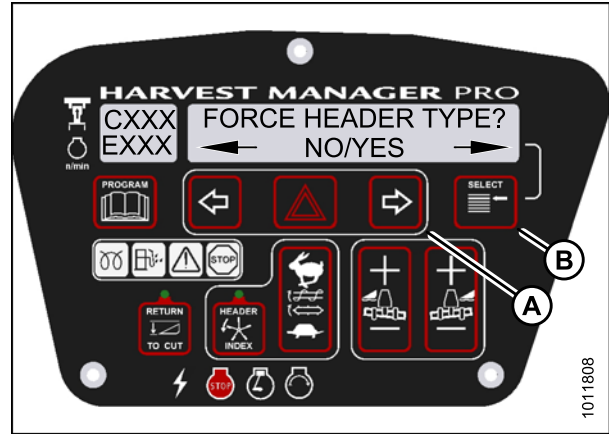

Figure 4.102: Header Type

7. Press left (A) or right (B) arrow to cycle through list of header types.
8. When desired header type is displayed press SELECT (C).
 - EXIT FORCE HEADER? is displayed on the upper line.
 - NO/YES is displayed on the lower line.
9. Press right arrow (B) to select YES. Press SELECT (C). Proceed to next DIAGNOSTIC MODE or press PROGRAM to exit programming mode.

4.8 Troubleshooting Header Problems

You can test individual parts of the header as part of a troubleshooting routine.

4.8.1 Testing the Header Up/Down Activate Function Using the Cab Display Module (CDM)

NOTE:

- The header **MUST** be attached to the windrower to perform this procedure. The cab display module (CDM) automatically adjusts its programming for each header.
- The engine **MUST** be running to perform this procedure.

1. Turn ignition key to RUN, or start the engine.
2. Press PROGRAM (A) and SELECT (C) on cab display module (CDM) to enter Programming Mode. Press SELECT (C).
 - WINDROWER SETUP? is displayed on the upper line.

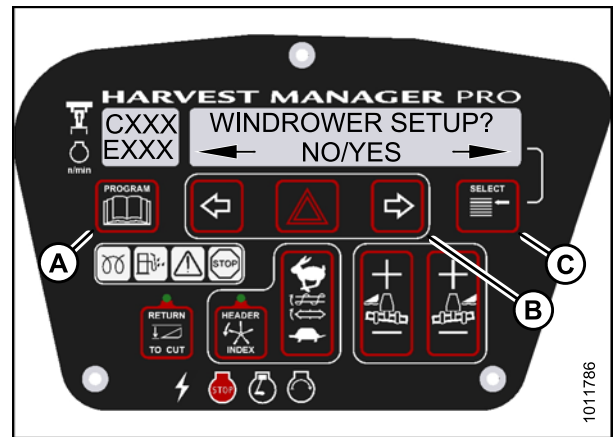

Figure 4.103: CDM Programming Buttons

3. Press SELECT (B) until DIAGNOSTIC MODE? is displayed in upper line.
 - NO/YES is displayed on the lower line.
4. Press right (A) arrow to select YES. Press SELECT (B).

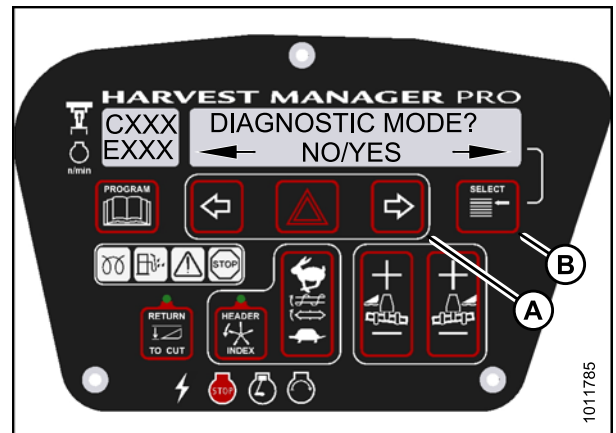

Figure 4.104: Diagnostic Functions

CAB DISPLAY MODULE (CDM)

5. Press SELECT (B) until ACTIVATE FUNCTIONS? is displayed on the upper line.
 - NO/YES is displayed on the lower line.
6. Press right (A) arrow to select YES. Press SELECT (B).



Figure 4.105: Functions

CAUTION

Check to be sure all bystanders have cleared the area.

7. Press SELECT (D) until ACTIVATE HEADER HT is displayed on the upper line.
 - DOWN/UP is displayed on the lower line.
8. Press and hold left (B) arrow to lower header, or press and hold right (C) arrow to raise header. Verify header is functioning properly.
9. Press PROGRAM (A) to exit Programming Mode or press SELECT (D) to proceed to next ACTIVATE FUNCTION.

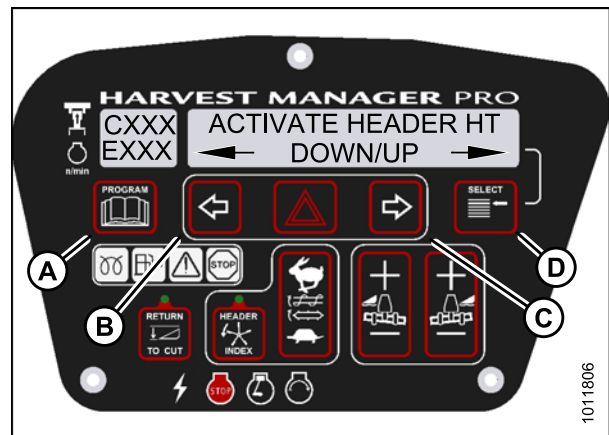

Figure 4.106: Header Height

4.8.2 Testing the Reel Up/Down Activate Function Using the Cab Display Module (CDM)

NOTE:

- This procedure is for draper headers only.
- The header **MUST** be attached to the windrower to perform this procedure. The cab display module (CDM) automatically adjusts its programming for each header.

CAB DISPLAY MODULE (CDM)

1. Turn ignition key to RUN, or start the engine.
2. Press PROGRAM (A) and SELECT (C) on cab display module (CDM) to enter Programming Mode. Press SELECT (C).

- WINDROWER SETUP? is displayed on the upper line.

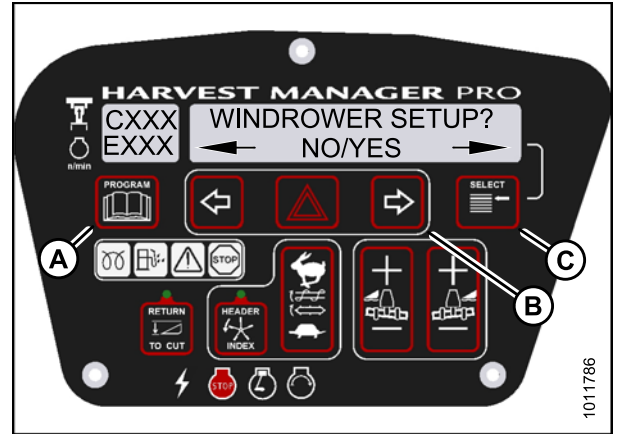

Figure 4.107: CDM Programming Buttons

3. Press SELECT (B) until DIAGNOSTIC MODE? is displayed in upper line.
 - NO/YES is displayed on the lower line.
4. Press right (A) arrow to select YES. Press SELECT (B).

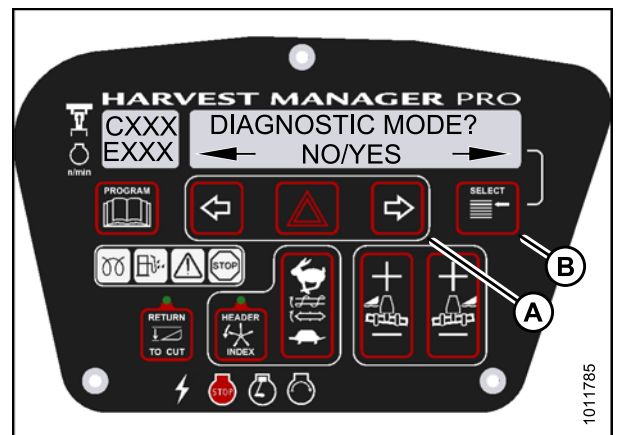

Figure 4.108: Diagnostic Functions

5. Press SELECT (D) until ACTIVATE FUNCTIONS? is displayed on the upper line.
 - NO/YES is displayed on the lower line.
6. Press right (C) arrow to select YES. Press SELECT (D).

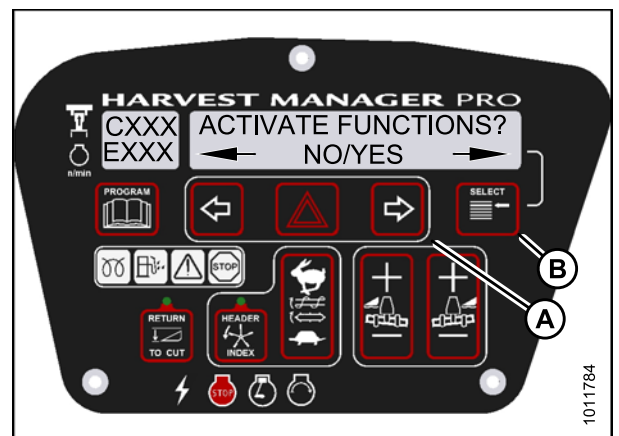

Figure 4.109: Functions

CAB DISPLAY MODULE (CDM)

CAUTION

Check to be sure all bystanders have cleared the area.

7. Press SELECT (D) until ACTIVATE REEL HT is displayed on the upper line.
 - DOWN/UP is displayed on the lower line.
8. Press and hold left (B) arrow to **lower** reel. Press and hold right (C) arrow to **raise** reel.
Verify reel is functioning properly.
9. Press PROGRAM (A) to exit Programming Mode or press SELECT (D) to proceed to next ACTIVATE FUNCTION.

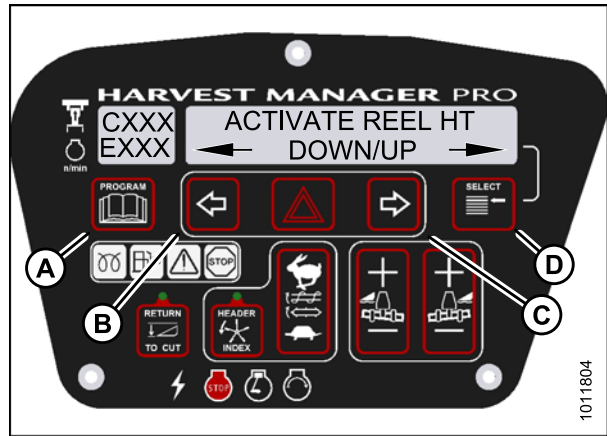

Figure 4.110: Reel Height

4.8.3 Testing the Header Tilt Activate Function Using the Cab Display Module (CDM)

NOTE:

- The header **MUST** be attached to the windrower to perform this procedure. The cab display module (CDM) automatically adjusts its programming for each header.
 - The engine **MUST** be running to perform this procedure.
1. Turn ignition key to RUN, or start the engine.
 2. Press PROGRAM (A) and SELECT (C) on cab display module (CDM) to enter Programming Mode.
 - WINDROWER SETUP? is displayed on the upper line.

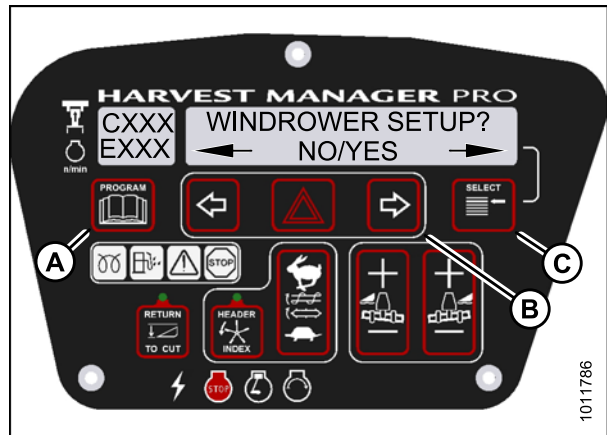

Figure 4.111: CDM Programming Buttons

CAB DISPLAY MODULE (CDM)

3. Press SELECT (B) until DIAGNOSTIC MODE? is displayed in upper line.
 - NO/YES is displayed on the lower line.
4. Press right (A) arrow to select YES. Press SELECT (B).

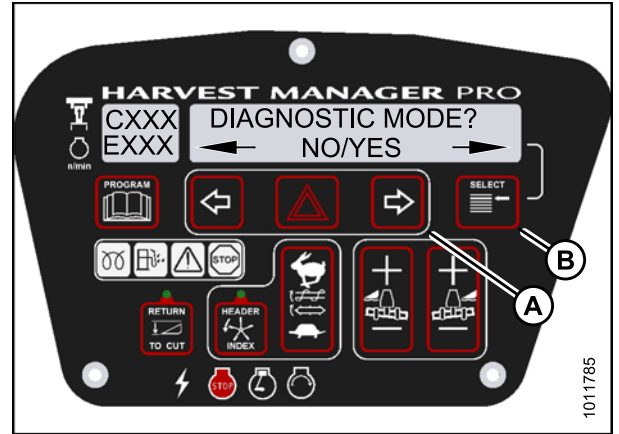

Figure 4.112: Diagnostic Functions

5. Press SELECT (D) until ACTIVATE FUNCTIONS? is displayed on the upper line.
 - NO/YES is displayed on the lower line.
6. Press right (C) arrow to select YES. Press SELECT (D).

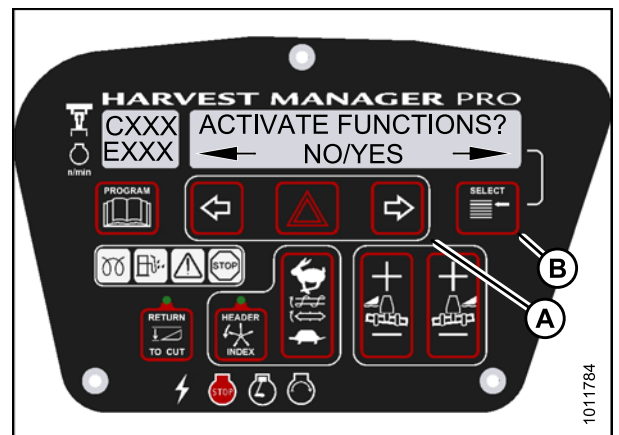

Figure 4.113: Functions

CAUTION

Check to be sure all bystanders have cleared the area.

7. Press SELECT (D) until ACTIVATE HDR TILT is displayed on the upper line.
 - IN/OUT is displayed on the lower line.
8. Press and hold left (B) arrow to **decrease** header tilt. Press and hold right (C) arrow to **increase** header tilt. **Verify header is functioning properly.**
9. Press PROGRAM (A) to exit Programming Mode or press SELECT (D) to proceed to next ACTIVATE FUNCTION.

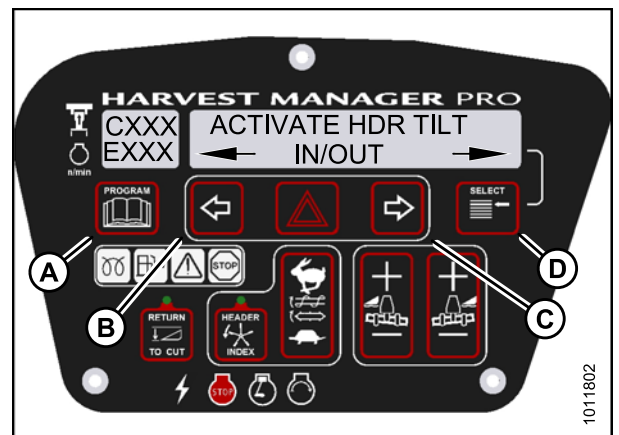

Figure 4.114: Header Tilt Angle

4.8.4 Testing the Reel Fore-Aft Activate Function Using the Cab Display Module (CDM)

NOTE:

- The header **MUST** be attached to windrower to perform this procedure. For more information, refer to [3.9 Attaching Headers, page 27](#).
- The engine **MUST** be running to perform this procedure.

1. Turn ignition key to RUN, or start the engine.
2. Press PROGRAM (A) and SELECT (C) on cab display module (CDM) to enter Programming Mode.
 - WINDROWER SETUP? is displayed on the upper line.

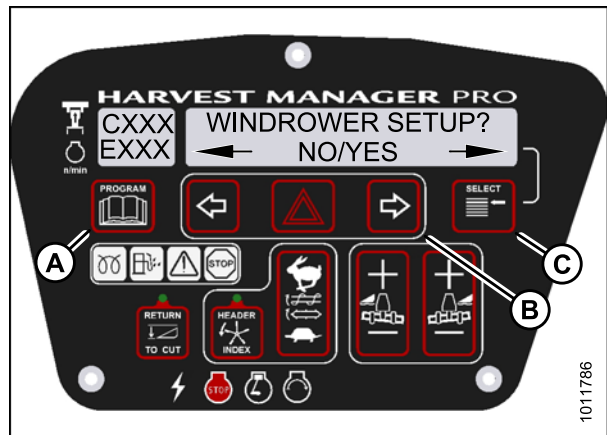

Figure 4.115: CDM Programming Buttons

3. Press SELECT (B) until DIAGNOSTIC MODE? is displayed in upper line.
 - NO/YES is displayed on the lower line.
4. Press right (A) arrow to select YES. Press SELECT (B).

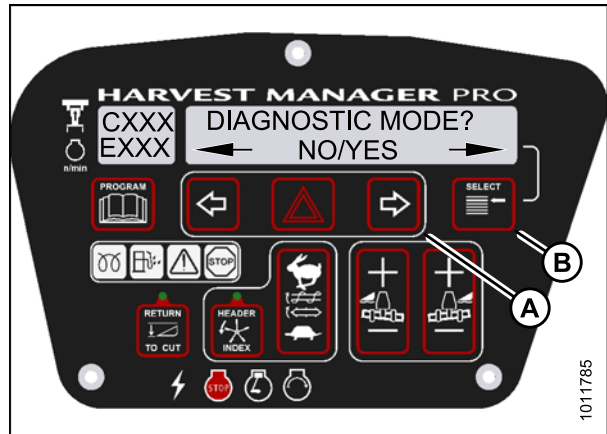

Figure 4.116: Diagnostic Functions

CAB DISPLAY MODULE (CDM)

5. Press SELECT (D) until ACTIVATE FUNCTIONS? is displayed on the upper line.
 - NO/YES is displayed on the lower line.
6. Press right (C) arrow to select YES. Press SELECT (D).

CAUTION

Check to be sure all bystanders have cleared the area.



Figure 4.117: Functions

7. Press SELECT (D) until ACTIVATE REEL F/A is displayed on the upper line.
 - FORE/AFT is displayed on the lower line.
8. Verify reel fore-aft is functioning properly.
 - a. Press and hold left (B) arrow to move reel **forward**. Press and hold right (C) arrow to move reel **backward**.
 - b. Press PROGRAM (A) to exit Programming Mode or press SELECT (D) to proceed to next ACTIVATE FUNCTION.

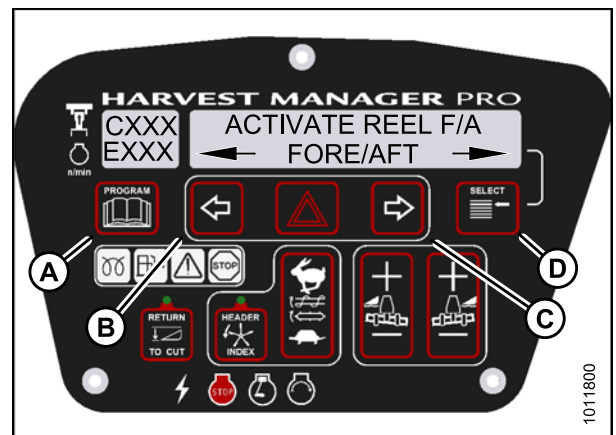

Figure 4.118: Reel Fore-Aft

4.8.5 Activating the Hydraulic Purge Using the Cab Display Module (CDM)

The hydraulic purge removes air from the hydraulic pump system after it has been repaired or changed.

NOTE:

Engine **MUST** be running to perform this procedure.

1. Turn ignition key to RUN, or start the engine.
2. Press PROGRAM (A) and SELECT (C) on cab display module (CDM) to enter Programming Mode.
 - WINDROWER SETUP? is displayed on the upper line.

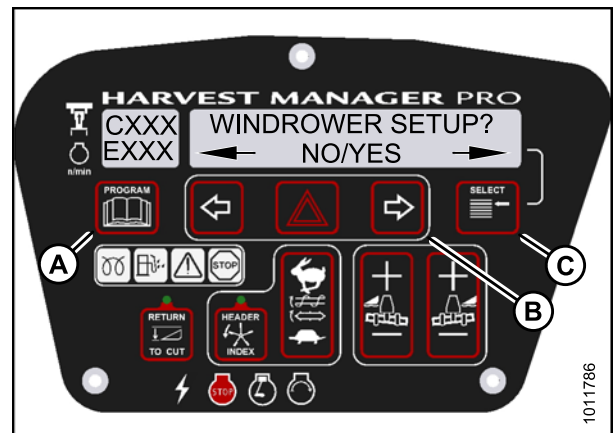

Figure 4.119: CDM Programming Buttons

CAB DISPLAY MODULE (CDM)

3. Press SELECT (B) until DIAGNOSTIC MODE? is displayed in upper line.
 - NO/YES is displayed on the lower line.
4. Press right (A) arrow to select YES. Press SELECT (B).

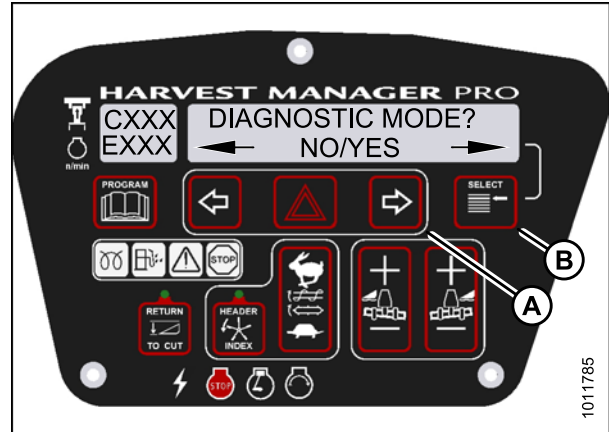

Figure 4.120: Diagnostic Functions

5. Press SELECT (B) until ACTIVATE FUNCTIONS? is displayed on the upper line.
 - NO/YES is displayed on the lower line.
6. Press right (A) arrow to select YES. Press SELECT (B).
 - ACTIVATE HEADER HT is displayed on the upper line.
 - DOWN/UP is displayed on the lower line.



Figure 4.121: Functions

7. Press SELECT (B) until ACTIVATE HYD PURGE? is displayed on the upper line.
 - NO/YES is displayed on the lower line.
8. Press right (A) arrow to select YES. Press SELECT (B).
 - TO ACTIVATE PURGE is displayed on the upper line.
 - PRESS AND HOLD is displayed on the lower line.

CAUTION

Check to be sure all bystanders have cleared the area.



Figure 4.122: Hydraulic Purge

CAB DISPLAY MODULE (CDM)

NOTE:

Holding the right arrow (A) activates a timed purge cycle. The CDM will jump to the exit menu if the arrow is released before the end of the timed cycle.

9. Press and hold right (A) arrow to activate purge cycle.
 - PURGE CYCLE STARTED will display on the upper line.
10. When PURGE CYCLE ENDED is displayed release right (A) arrow.
 - NO EXIT YES is displayed on the lower line.
11. Press right arrow to select YES. Press SELECT.
12. Press PROGRAM to exit Programming Mode or press SELECT to proceed to next ACTIVATE FUNCTION.



Figure 4.123: Hydraulic Purge Cycle

4.8.6 Testing the Knife Drive Circuit Using the Cab Display Module (CDM)

IMPORTANT:

Do not over-speed a drive. Over-speeding can lead to vibration, belt failures, or other over-speeding related problems.

NOTE:

- The header **MUST** be attached to windrower to follow this procedure.
1. Turn ignition key to RUN, or start the engine.
 2. Press PROGRAM (A) and SELECT (C) on cab display module (CDM) to enter Programming Mode. Press SELECT (C).
 - WINDROWER SETUP? is displayed on the upper line.

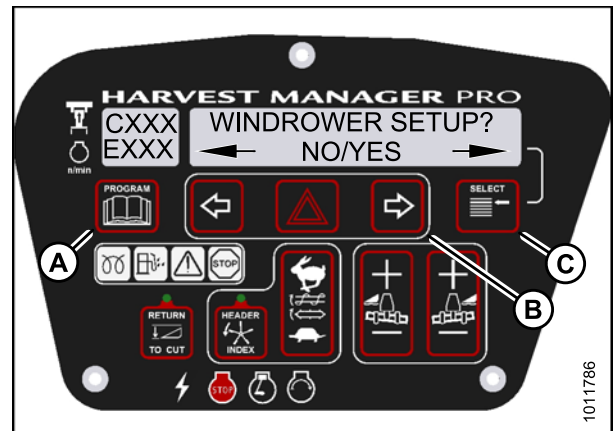

Figure 4.124: CDM Programming Buttons

CAB DISPLAY MODULE (CDM)

3. Press SELECT (B) until DIAGNOSTIC MODE? is displayed in upper line.
 - NO/YES is displayed on the lower line.
4. Press right (A) arrow to select YES. Press SELECT (B).

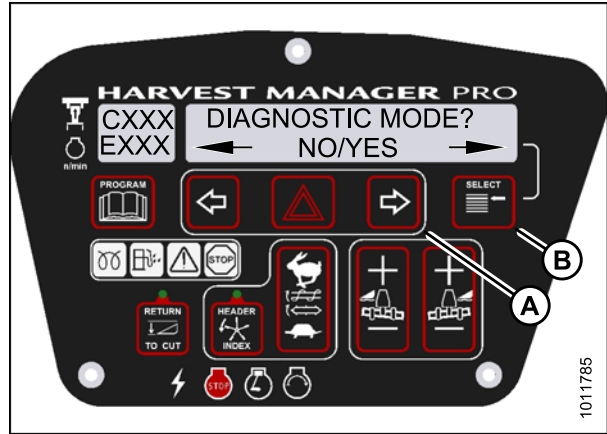

Figure 4.125: Diagnostic Functions

5. Press SELECT (B) until ACTIVATE FUNCTIONS? is displayed on the upper line.
 - NO/YES is displayed on the lower line.
6. Press right (A) arrow to select YES. Press SELECT (B).
 - ACTIVATE HEADER HT is displayed on the upper line.



Figure 4.126: Functions

CAUTION

Check to be sure all bystanders have cleared the area.

7. Press SELECT (E) until KNIFE DRIVE SPD XXXX is displayed on the upper line.

IMPORTANT:

Do **NOT** over speed the knife drive.

8. Press and hold HAZARD (C) button.
 - Press left (B) arrow to **decrease** knife speed.
 - Press right (D) arrow to **increase** knife speed.

Verify the knife drive is functioning properly.

9. Release the HAZARD (C) button. The knife will stop.
10. Press PROGRAM (A) to exit Programming Mode or press SELECT (E) to proceed to next ACTIVATE FUNCTION.

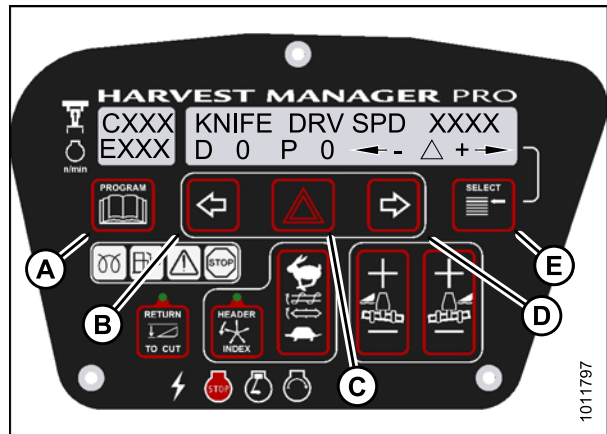

Figure 4.127: Knife Drive

CAB DISPLAY MODULE (CDM)

4.8.7 Testing the Draper Drive Circuit Activate Function Using the Cab Display Module (CDM)

IMPORTANT:

Do not over-speed a drive. Over-speeding can lead to vibration, belt failures, or other over-speeding related problems.

NOTE:

- A draper header **MUST** be attached to windrower to follow this procedure.
 - The engine **MUST** be running to perform this procedure.
1. Turn ignition key to RUN, or start the engine.
 2. Press PROGRAM (A) and SELECT (C) on cab display module (CDM) to enter Programming Mode.
 - WINDROWER SETUP? is displayed on the upper line.

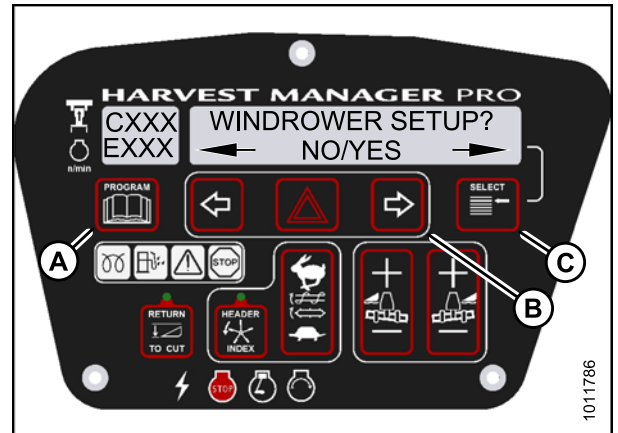

Figure 4.128: CDM Programming Buttons

3. Press SELECT (B) until DIAGNOSTIC MODE? is displayed in upper line.
 - NO/YES is displayed on the lower line.
4. Press right (A) arrow to select YES. Press SELECT (B).

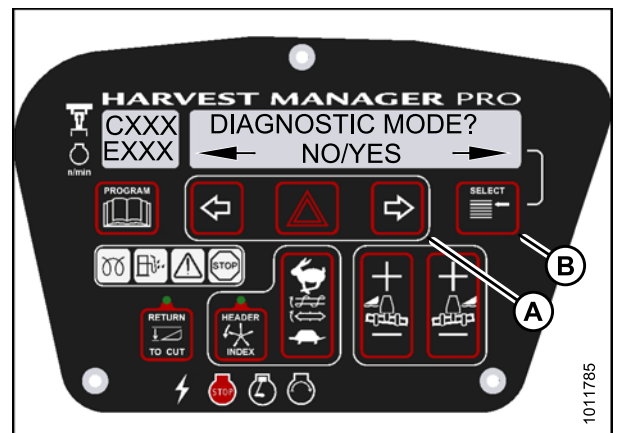

Figure 4.129: Diagnostic Functions

CAB DISPLAY MODULE (CDM)

5. Press SELECT (B) until ACTIVATE FUNCTIONS? is displayed on the upper line.
 - NO/YES is displayed on the lower line.
6. Press right (A) arrow to select YES. Press SELECT (B).
 - ACTIVATE HEADER HT is displayed on the upper line.



Figure 4.130: Functions

CAUTION

Check to be sure all bystanders have cleared the area.

7. Press SELECT (B) until DRAPER DRV SPD XXXX is displayed on the upper line.

IMPORTANT:

Do **NOT** over speed the drapers.

8. Press and hold HAZARD (C) button.
 - Press left (B) arrow to **decrease** draper speed.
 - Press right (D) arrow to **increase** draper speed.

Verify the draper drive is functioning properly.

9. Release the HAZARD (C) button. The drapers will stop.
10. Press PROGRAM (A) to exit Programming Mode or press SELECT (E) to proceed to next ACTIVATE FUNCTION.

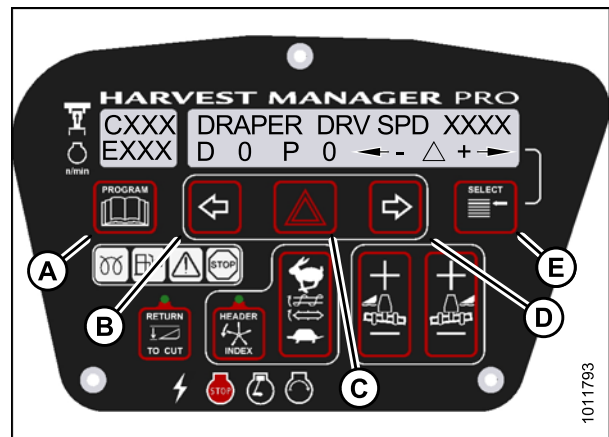

Figure 4.131: Draper Drive

4.8.8 Testing the Reel Drive Circuit Activate Function Using the Cab Display Module (CDM)

IMPORTANT:

Do not over-speed a drive. Over-speeding can lead to vibration, belt failures, or other over-speeding related problems.

NOTE:

- The header **MUST** be attached to windrower to follow this procedure. For more information, refer to [3.9 Attaching Headers, page 27](#).
- This procedure does not apply to rotary disc headers.
- The engine **MUST** be running to perform this procedure.

CAB DISPLAY MODULE (CDM)

1. Turn ignition key to RUN, or start the engine.
2. Press PROGRAM (A) and SELECT (C) on cab display module (CDM) to enter Programming Mode.
 - WINDROWER SETUP? is displayed on the upper line.

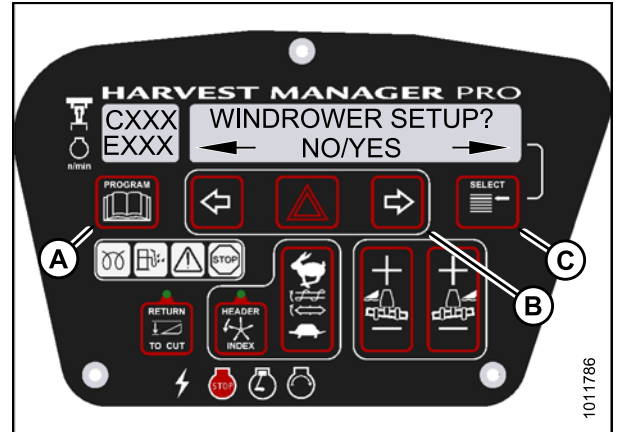

Figure 4.132: CDM Programming Buttons

3. Press SELECT (B) until DIAGNOSTIC MODE? is displayed in upper line.
 - NO/YES is displayed on the lower line.
4. Press right (A) arrow to select YES. Press SELECT (B).

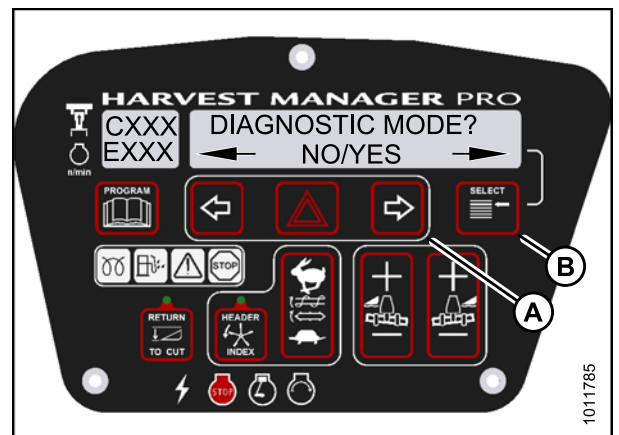

Figure 4.133: Diagnostic Functions

5. Press SELECT (B) until ACTIVATE FUNCTIONS? is displayed on the upper line.
 - NO/YES is displayed on the lower line.
6. Press right (A) arrow to select YES. Press SELECT (B).
 - ACTIVATE HEADER HT is displayed on the upper line.

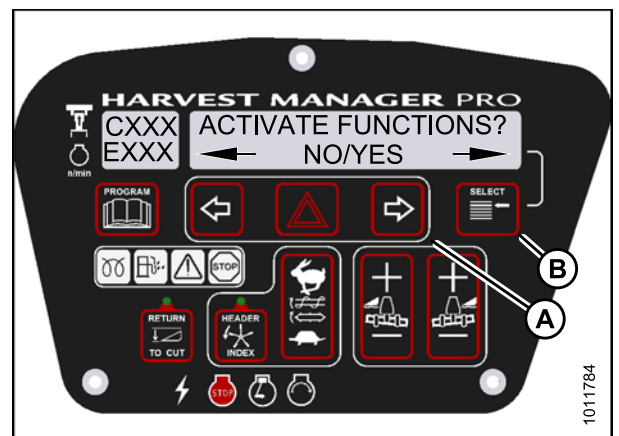

Figure 4.134: Functions

CAB DISPLAY MODULE (CDM)

CAUTION

Check to be sure all bystanders have cleared the area.

7. Press SELECT (E) until REEL DRV SPD XXXX is displayed on the upper line.

IMPORTANT:

Do **NOT** over speed the reel.

8. Press and hold HAZARD (C) button.
 - Press left (B) arrow to **decrease** reel speed.
 - Press right (D) arrow to **increase** reel speed.

Verify the reel drive is functioning properly.

9. Release the HAZARD (C) button. The reel will stop.
10. Press PROGRAM (A) to exit Programming Mode or press SELECT (E) to proceed to next ACTIVATE FUNCTION.

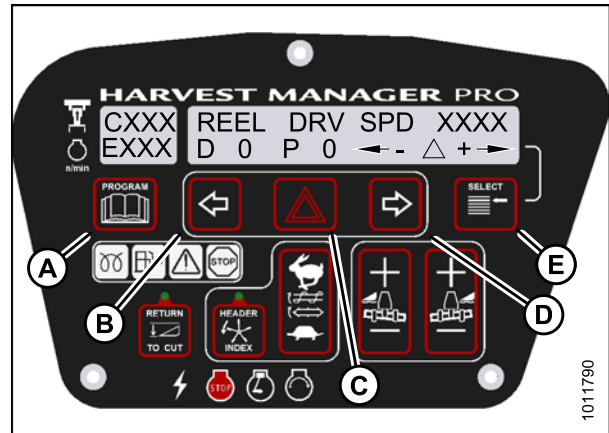

Figure 4.135: Reel Drive

4.8.9 Testing the Rotary Disc Drive Circuit Activate Function Using the Cab Display Module (CDM)

IMPORTANT:

Do not over-speed a drive. Over-speeding can lead to vibration, belt failures, or other over-speeding related problems.

NOTE:

- A rotary disc header **MUST** be attached to windrower to follow this procedure.
- The engine **MUST** be running to perform this procedure.

1. Turn ignition key to RUN, or start the engine.
2. Press PROGRAM (A) and SELECT (C) on cab display module (CDM) to enter Programming Mode.
 - WINDROWER SETUP? is displayed on the upper line.

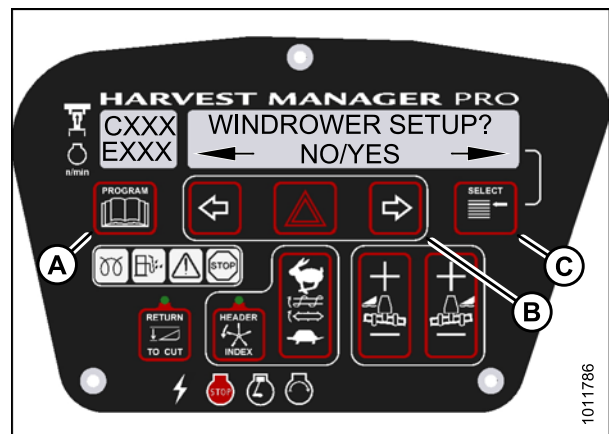

Figure 4.136: CDM Programming Buttons

CAB DISPLAY MODULE (CDM)

- Press SELECT (B) until DIAGNOSTIC MODE? is displayed in upper line.
 - NO/YES is displayed on the lower line.
- Press right (A) arrow to select YES. Press SELECT (B).

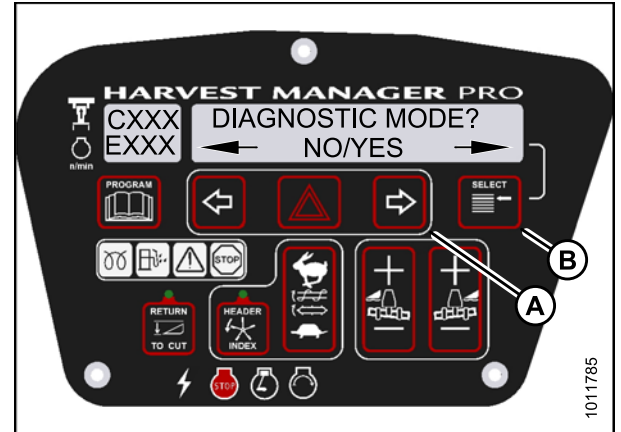

Figure 4.137: Diagnostic Functions

- Press SELECT (B) until ACTIVATE FUNCTIONS? is displayed on the upper line.
 - NO/YES is displayed on the lower line.
- Press right (A) arrow to select YES. Press SELECT (B).
 - ACTIVATE HEADER HT is displayed on the upper line.

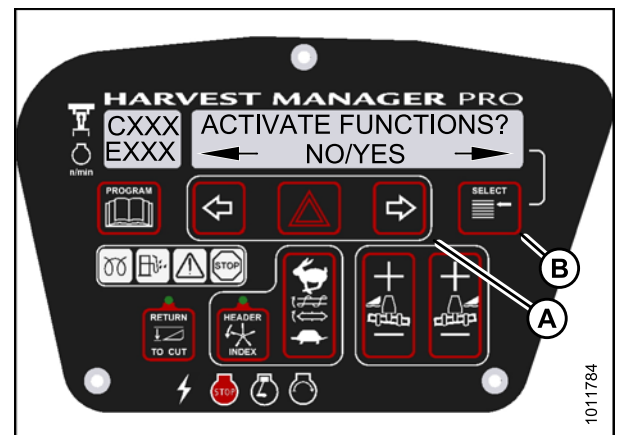

Figure 4.138: Functions

CAUTION

Check to be sure all bystanders have cleared the area.

- Press SELECT (E) until DISC DRV SPD XXXX is displayed on the upper line.

IMPORTANT:

Do **NOT** over speed the disc drive.

- Press and hold HAZARD (C) button.
 - Press left (B) arrow to **decrease** disc speed.
 - Press right (D) arrow to **increase** disc speed.

Verify the disc drive is functioning properly.

- Release the HAZARD (C) button. The disc drive will stop.
- Press PROGRAM to exit Programming Mode or press SELECT to proceed to next ACTIVATE FUNCTION.

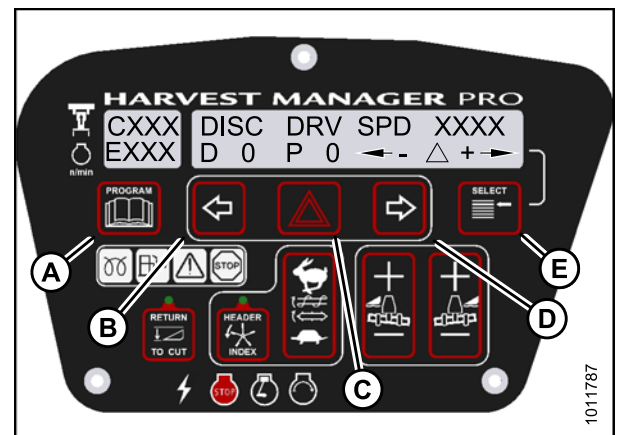

Figure 4.139: Disc Drive

4.8.10 Testing the Double Windrower Attachment (DWA) Drive Activate Function Using the Cab Display Module (CDM)

IMPORTANT:

Do not over-speed a drive. Over-speeding can lead to vibration, belt failures, or other over-speeding related problems.

NOTE:

- DWA must be attached to windrower and activated under the WINDROWER SETUP menu. For more information, refer to [4.4.10 Activating the Double Windrow Attachment \(DWA\), page 88](#).

- Engine **MUST** be running to perform this procedure.

1. Turn ignition key to RUN, or start the engine.
2. Press PROGRAM (A) and SELECT (C) on cab display module (CDM) to enter Programming Mode. Press SELECT (C).
 - WINDROWER SETUP? is displayed on the upper line.

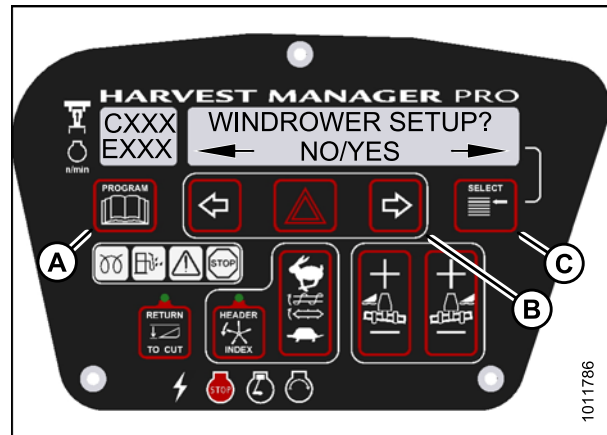

Figure 4.140: CDM Programming Buttons

3. Press SELECT (B) until DIAGNOSTIC MODE? is displayed in upper line.
 - NO/YES is displayed on the lower line.
4. Press right (A) arrow to select YES. Press SELECT (B).

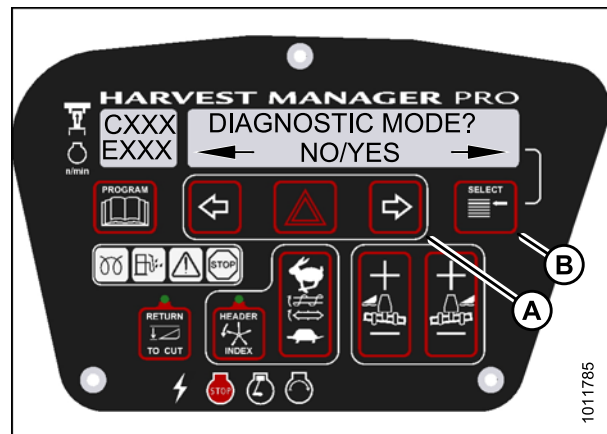

Figure 4.141: Diagnostic Functions

CAB DISPLAY MODULE (CDM)

5. Press SELECT (B) until ACTIVATE FUNCTIONS? is displayed on the upper line.
 - NO/YES is displayed on the lower line.
6. Press right (A) arrow to select YES. Press SELECT (B).
 - ACTIVATE HEADER HT is displayed on the upper line.



Figure 4.142: Functions

7. Press SELECT (E) until ACTIVATE DWA DRV is displayed on the upper line.

CAUTION

Check to be sure all bystanders have cleared the area.

IMPORTANT:

Do **NOT** over speed the DWA drive.

8. Press and hold HAZARD (C) button.
 - Press left (B) arrow to decrease DWA drive speed.
 - Press right (D) arrow to increase DWA drive speed.

Verify the DWA drive is functioning properly.

9. Release the HAZARD (C) button. The DWA drive will stop.
10. Press PROGRAM (A) to exit Programming Mode or press SELECT (E) to proceed to next ACTIVATE FUNCTION.

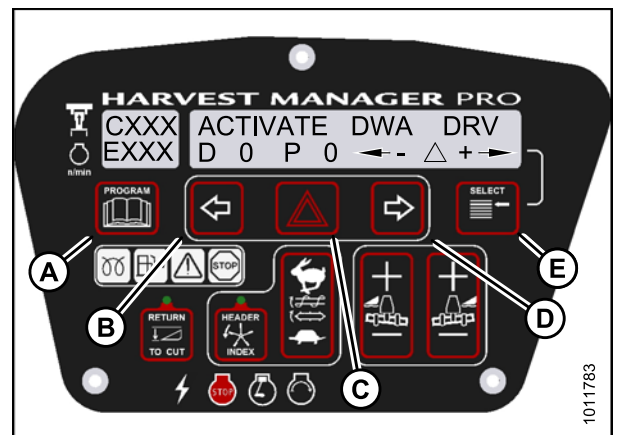

Figure 4.143: DWA Drive

5 Performing Predelivery Checks

Perform all procedures in this chapter in the order in which they are listed.

DANGER

To avoid bodily injury or death from unexpected startup of the machine, always stop the engine and remove the key from the ignition before leaving the operator's seat for any reason.

IMPORTANT:

The machine is factory-set and should not require further adjustments; however, perform the following checks to ensure your machine operates at maximum performance. Adjustments should be made only if absolutely necessary and in accordance with the instructions in this manual.

5.1 Recording Serial Numbers

Record the windrower and engine serial numbers on the Predelivery Checklist.

1. The windrower serial number plate (A) is located on the left side of the main frame near the walking beam as shown.

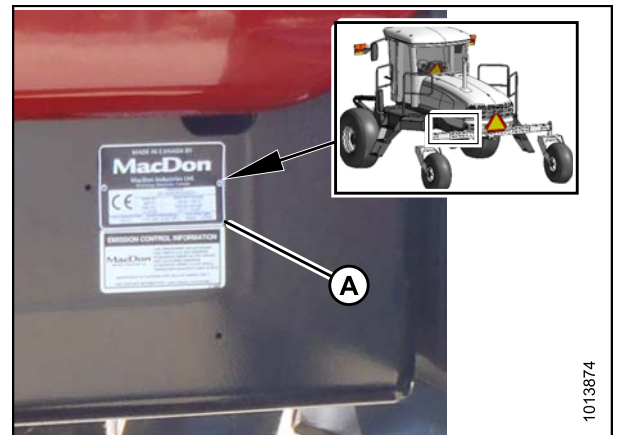

Figure 5.1: Serial Number Location

2. The engine serial number plate (A) is located on top of the engine cylinder head cover as shown.

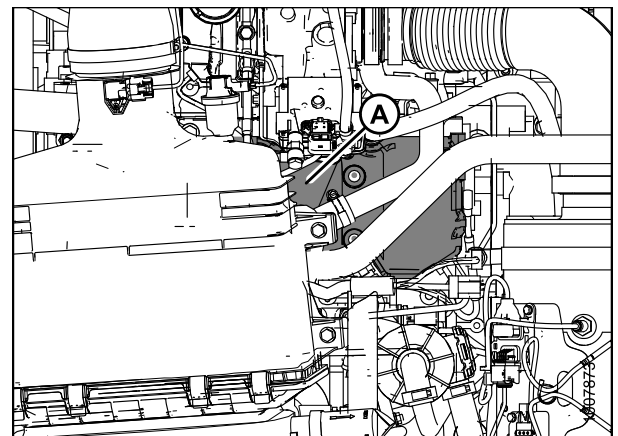

Figure 5.2: Engine Serial Number Location

5.2 Checking Wheel Drive Lubricant Level

⚠ DANGER

To avoid bodily injury or death from unexpected startup of the machine, always stop the engine and remove the key from the ignition before leaving the operator's seat for any reason.

1. Park the windrower on level ground.
2. Position windrower so plugs (A and B) are horizontally aligned with the center (C) of the hub.
3. Stop the engine and remove the key.
4. Remove plug (A or B). The lubricant should be visible through the port or running out slightly. If lubricant needs to be added, refer to the windrower operator's manual for specifications.
5. Reinstall plugs and tighten.

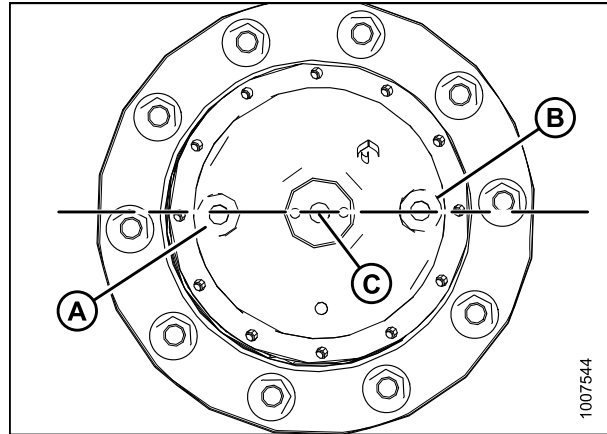

Figure 5.3: Drive Wheel Hub

5.3 Checking Tire Pressures and Adding Tire Ballast

5.3.1 Checking Tire Pressures

Check tire pressures with a gauge.

Table 5.1 Tire Pressures

Tire Type	Size	Pressure
Bar	18.4–26	221 kPa (32 psi)
	600/65R28	179 kPa (26 psi)
Turf	18.4–26	241 kPa (35 psi)
	23.1–26	138 kPa (20 psi)
	580/70R26	165 kPa (24 psi)
Rear Caster	All	69 kPa (10 psi)

5.3.2 Adding Tire Ballast

When using large headers on windrower, adding fluid ballast to rear caster tires will improve machine stability.

Machine stability is also affected by different attachments, windrower options, terrains, and driving techniques.

Ballast capability per tire is at a maximum fill of 75% or when fluid is level with valve stem when stem is positioned at 12 o'clock position.

Always add an equal amount of fluid on both sides. Fluid can be added to any level up to maximum fill.

Table 5.2 Fluid per Tire

Tire Size	Fluid per Tire at 75% Fill Liters (U.S. Gal.)	Total Weight of Both Tires Kg (Lb.) ⁸
7.5 x 16	38 (10)	91 (200)
10 x 16	69 (18)	170 (380)
16.5 x 16.1	158 (41)	377 (830)

8. Weights given are for typical calcium chloride and water mixtures. Weight is reduced by 20% if only water is used (for areas that do not require antifreeze protection).

PERFORMING PREDELIVERY CHECKS

Table 5.3 Recommended Ballast

Header Description		Recommended Tire Size	Recommended Ballast			
			Level Ground		Hills	
Type	Size		Per Tire liters (U.S. Gal.)	Both Tires kg (lb.) ⁹	Per Tire liters (U.S. Gal.)	Both Tires kg (lb.) ⁹
A-Series (all options)	All	7.5 x 16 10 x 16 16.5 x 16.1	0	0	0	0
D-Series	25 ft. and less		0	0	0	0
	30 ft. single reel or double reel (without conditioner)	7.5 x 16 10 x 16 16.5 x 16.1	69 (18)	170 (380)	115 (30)	288 (630)
	35 ft. single reel					
	30 ft. double reel (with steel fingers and conditioner)	Level ground: 10 x 16 16.5 x 16.1	115 (30)	288 (630)	158 (41)	377 (830)
	35 ft. double reel (5- or 6-bat)	Hills: 16.5 x 16.1				
40 ft.	16.5 x 16.1					
R-Series (all options)	13 ft.	7.5 x 16 10 x 16 16.5 x 16.1	0	0	0	0

9. If only water is used, increase volume of water by 20% (up to maximum allowable fill per tire) to compensate.

5.4 Checking Engine Air Intake

DANGER

To avoid bodily injury or death from unexpected startup of the machine, always stop the engine and remove the key from the ignition before leaving the operator's seat for any reason.

1. Ensure clips (A) are properly latched to, and plenum box (C) is securely attached onto, cover (B).

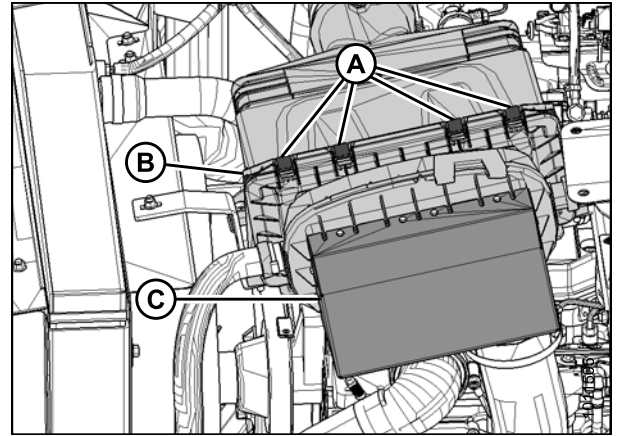

Figure 5.4: Air Intake System

2. Check gap of constant torque clamps by holding an 0.46 mm (0.018 in.) gauge (A) between the middle coils (B). Tighten clamps until gauge is snug, and remove gauge.

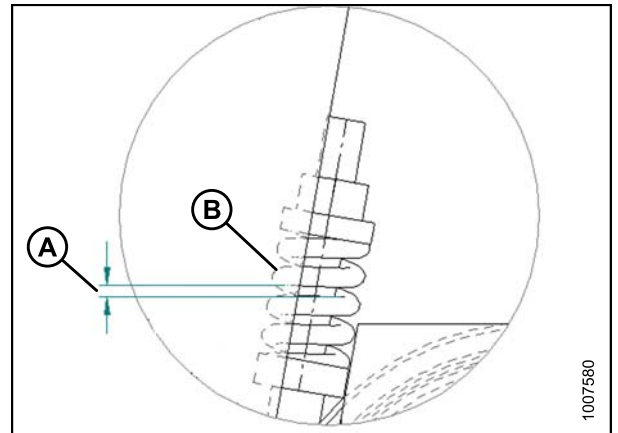

Figure 5.5: Constant Torque Clamp

3. Check four constant torque clamps (A) (two at air intake duct [B] and two at turbocharger tube [C]).

NOTE:

Some parts removed from illustration for clarity.

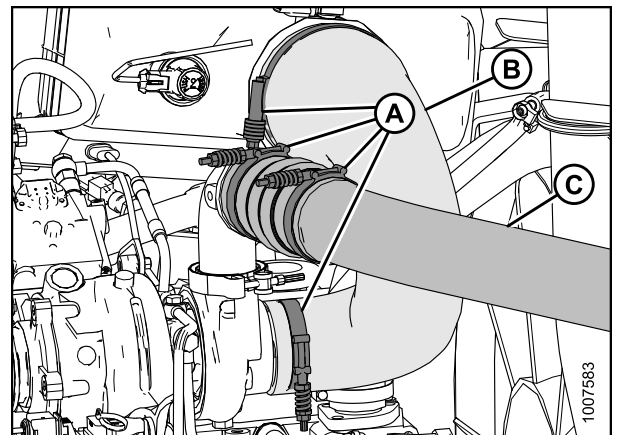

Figure 5.6: Air Intake System

PERFORMING PREDELIVERY CHECKS

4. Check the constant torque clamps (A) securing tube (B) from the cooler to the engine air intake.

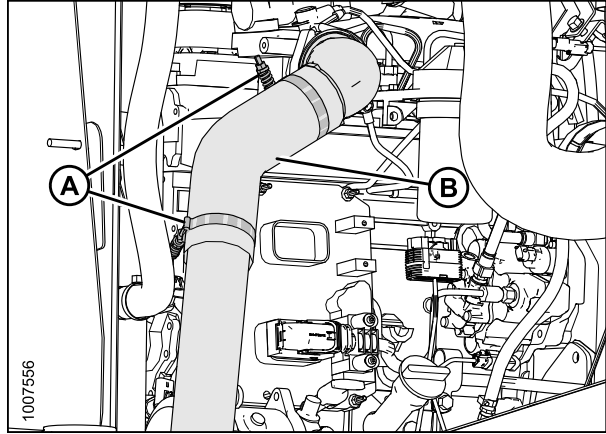

Figure 5.7: Air Intake System

5.5 Checking Hydraulic Oil

DANGER

To avoid bodily injury or death from unexpected startup of the machine, always stop the engine and remove the key from the ignition before leaving the operator's seat for any reason.

1. Stand on left (cab-forward side) platform to access the filler pipe.
2. Clean cap (A) and surrounding area.
3. Turn filler cap (A) counterclockwise to unlock cap and remove dipstick.

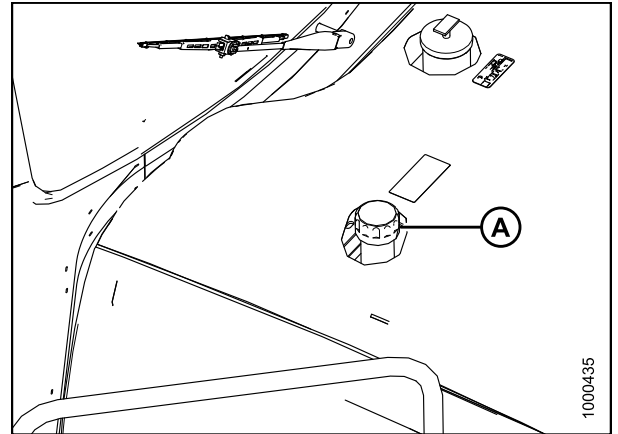

Figure 5.8: Engine Hood

4. Ensure hydraulic oil level is between the low (L) and full (H) marks.
5. If necessary, add oil to maintain a level between the low (L) and full (H) marks. Refer to the windrower operator's manual for specifications.
6. Reinstall dipstick and filler cap, and turn clockwise to tighten/lock.

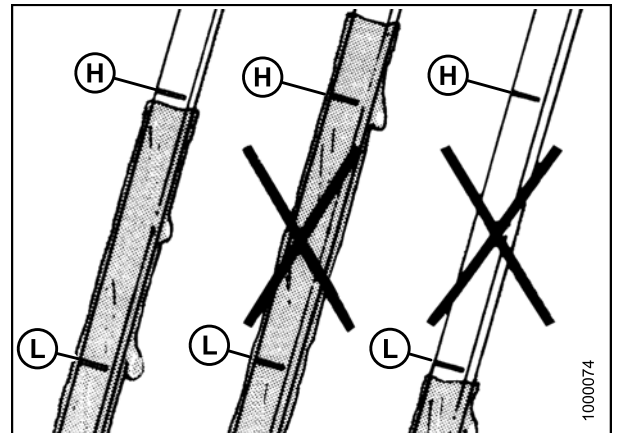

Figure 5.9: Hydraulic Oil Levels

5.6 Checking Fuel Separator

1. Place a container under the filter drain (A).
2. Turn drain valve (A) by hand 1-1/2 to 2 turns counterclockwise until fuel begins draining.
3. Drain the filter sump of water and sediment until clear fuel is visible. Clean as necessary.
4. Turn the drain valve (A) by hand 1-1/2 to 2 turns clockwise until tight.
5. Dispose of fluid in container in a safe manner.

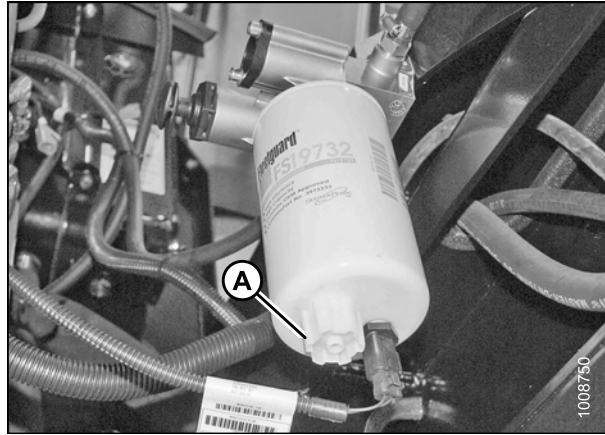

Figure 5.10: Fuel Filter

5.7 Checking Engine Coolant

1. Check the coolant level in the pressurized coolant tank (A).

NOTE:

Allow the engine to cool before checking coolant level. The pressurized coolant tank has MAX COLD and MIN COLD coolant level indicators (B), and coolant levels should be between these lines.

2. If necessary, add coolant. Refer to windrower operator's manual for specifications.
3. Ensure coolant concentration in the radiator is rated for temperatures of -34°C (-30°F).

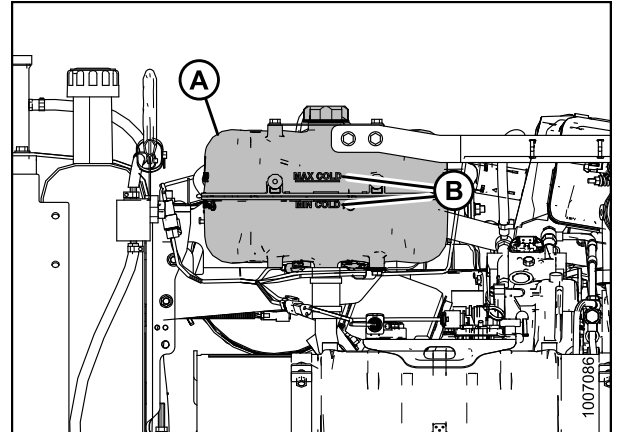

Figure 5.11: Pressurized Coolant Tank

5.8 Draining and Refilling the Diesel Exhaust Fluid (DEF) Tank

Drain the DEF tank at the time the windrower is received and refill with fresh DEF.

DANGER

To avoid bodily injury or death from unexpected startup of the machine, always stop the engine and remove the key from the ignition before leaving the operator's seat for any reason.

1. Open the maintenance platform on right cab-forward side.
2. Place a drain pan under the DEF tank.

IMPORTANT:

Any spilled DEF must be contained and absorbed by non-combustible absorbent material like sand and then shovelled to a suitable container for disposal. DEF is corrosive. If spilled on tank or any surface of the vehicle, rinse thoroughly with water.

WARNING

Diesel Exhaust Fluid (DEF) contains urea. Do NOT get the substance in your eyes. In case of contact, immediately flush eyes with water for a minimum of 15 minutes. Do NOT swallow. In the event the DEF is ingested, contact physician immediately.

3. Remove the drain plug (A) from under the tank (B) and drain.
4. Add some DEF to the tank (B) to flush out remaining contaminants.
5. Drain the DEF that was used to clean the tank.
6. Reinstall drain plug (A) in the tank (B).

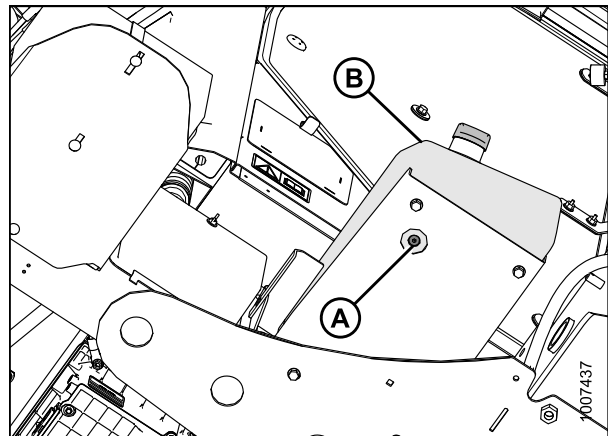

Figure 5.12: View from beneath Tank

IMPORTANT:

Before refilling the DEF tank, read the following instructions from decal (A) located on the tank cover.

- Before storing machine for periods of time greater than six months, drain DEF tank to prevent degradation of fluid.
- Before storing the machine in temperatures below 0°C (32°F), ensure level of fluid in DEF tank is 75 percent or lower.

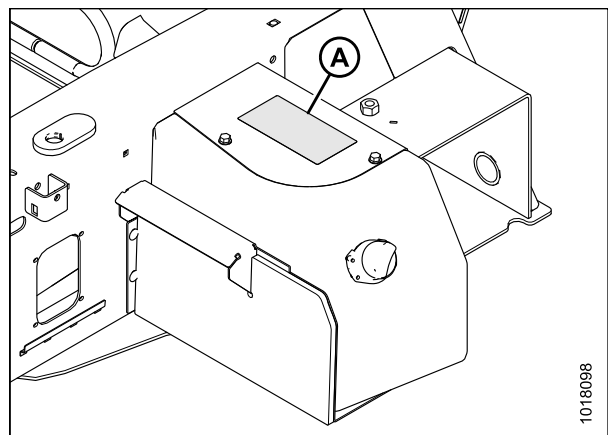

Figure 5.13: DEF Tank

PERFORMING PREDELIVERY CHECKS

Take the following precautions when handling DEF to prevent contamination:

- Avoid using funnels and containers that have been used with fuels or lubricants
 - Use only distilled water to rinse the components that store or deliver DEF; tap water can contaminate DEF
 - If distilled water is not available, use clean tap water, then rinse components with DEF
7. Clean around filler cap (A).
 8. Turn cap (A) counterclockwise until loose and remove cap.
 9. Fill the tank with an approved DEF. Refer to the windrower operator's manual for specifications.
 10. Replace filler cap (A) and turn clockwise until tight.
 11. Close the maintenance platform.

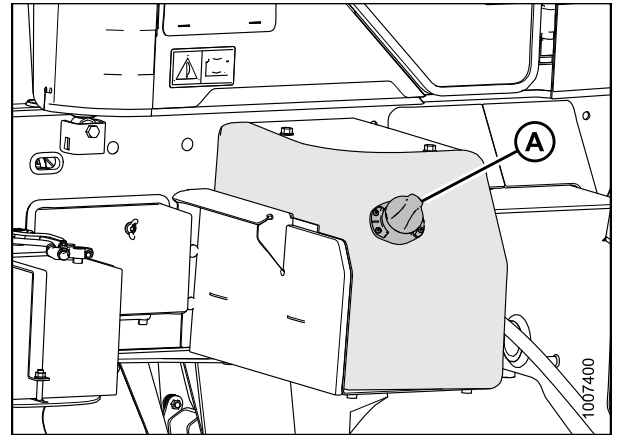

Figure 5.14: DEF Tank

5.9 Checking Gearbox Lubricant Level

1. Remove plug (A) and ensure lubricant is visible or slightly running out.
2. Add gearbox oil, if necessary. Refer to the windrower operator's manual for specifications.
3. Replace plug (A) and tighten.

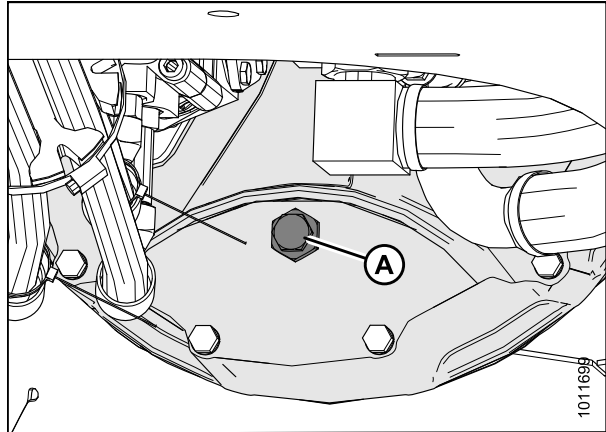

Figure 5.15: Gearbox

5.10 Checking Air Conditioning (A/C) Compressor Belts

1. Ensure A/C compressor belt (A) is tensioned so that a force of 35–55 N (8–12 lbf) on belt deflects belt 5 mm (3/16 in.) at mid-span.

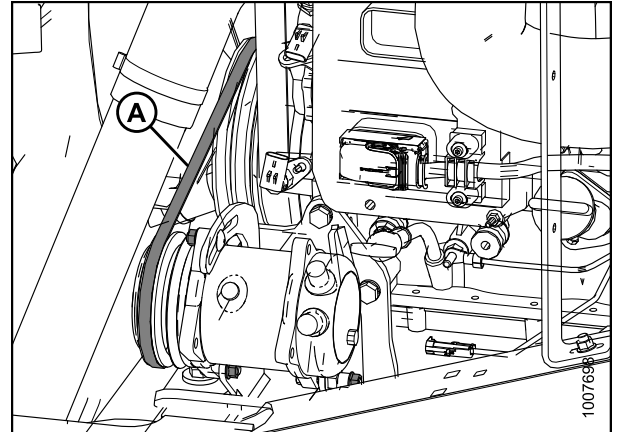

Figure 5.16: A/C Compressor Belt

5.11 Checking Safety System

Ensure the battery disconnect switch is in the POWER ON position. Refer to [5.12 Performing Operational Checks, page 146](#).

A properly functioning system should operate as follows:

- The starter should engage **only** when the ground speed lever (GSL) is in N-DETENT, the steering wheel is locked in the center position, and the header drive switch is in the OFF position. The brake should engage and the machine should NOT move after engine start-up.
- The steering wheel should **NOT** lock with the engine running and the GSL out of N-DETENT.
- The machine should **NOT** move with the engine running and with the steering wheel centered when the GSL is pulled straight out of N-DETENT (not in forward or reverse).

IMPORTANT:

If the safety system does not function as described, refer to the windrower technical manual.

 **DANGER**

To avoid bodily injury or death from unexpected startup of the machine, always stop the engine and remove the key from the ignition before leaving the operator's seat for any reason.

 **CAUTION**

Check to be sure all bystanders have cleared the area.

Perform the following procedures to ensure the safety system is operating properly:

1. Shut down the engine and engage header drive switch. Try starting the engine and confirm the cab display module (CDM) displays HEADER ENGAGED on the upper line and DISENGAGE HEADER on the lower line.

IMPORTANT:

If the engine turns over, the safety system requires adjustment. Refer to the windrower technical manual for adjustment procedures.

PERFORMING PREDELIVERY CHECKS

2. Shut down the engine and perform the following safety system checks:

- a. Open engine compartment hood.
- b. Pry the steering interlock away from pintle arms (A) by inserting a wedge or pry bar between one of the interlock channels (B) and pintle arm.
- c. Insert a wooden block approximately 19 mm (3/4 in.) thick between the opposite channel and the pintle arm so the interlock channel is clear of the pintle arm.
- d. Turn the steering wheel off-center and move the GSL to N-DETENT.
- e. Try starting the engine and confirm the CDM flashes CENTER STEERING accompanied by a short beep with each flash. The engine should **NOT** turn over.

IMPORTANT:

If the engine turns over, the safety system requires adjustment. Refer to the windrower technical manual for adjustment procedures.

- f. Remove key from ignition.
- g. Remove wooden block and close hood.

3. Shut down the engine and center the steering wheel. Place the GSL in NEUTRAL but not in N-DETENT. Try starting the engine and confirm the CDM flashes CENTER STEERING on the upper line and PLACE GSL INTO N on the lower line accompanied by a short beep with each flash. The engine should NOT turn over.

IMPORTANT:

If the engine turns over, the safety system requires adjustment. Refer to the windrower technical manual for adjustment procedures.

4. Shut down the engine and center the steering wheel. Place the GSL in N-DETENT and ensure the operator's station is **NOT** locked. Try starting the engine and confirm that the engine cranks but does NOT start, and the CDM displays SEAT BASE NOT LOCKED.

IMPORTANT:

If the engine starts, the safety system requires adjustment. Refer to the windrower technical manual for adjustment procedures.

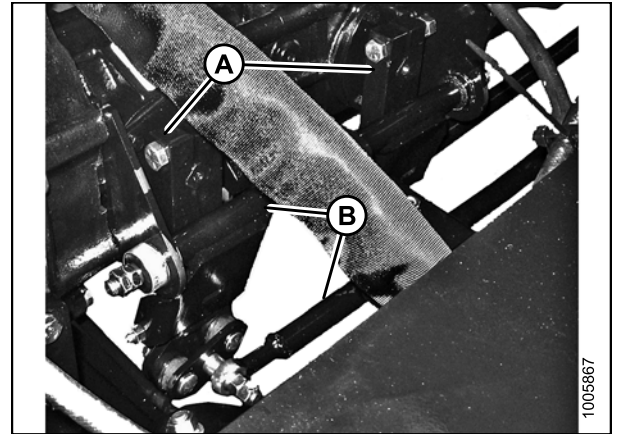

Figure 5.17: Pintle Arms

5.12 Performing Operational Checks

⚠ DANGER

To avoid bodily injury or death from unexpected startup of the machine, always stop the engine and remove the key from the ignition before leaving the operator's seat for any reason.

The battery disconnect switch (A) is located on the right-hand (cab-forward) frame rail behind the maintenance platform and can be accessed by moving the platform rearwards.

Ensure the battery disconnect switch (A) is in the POWER ON position.

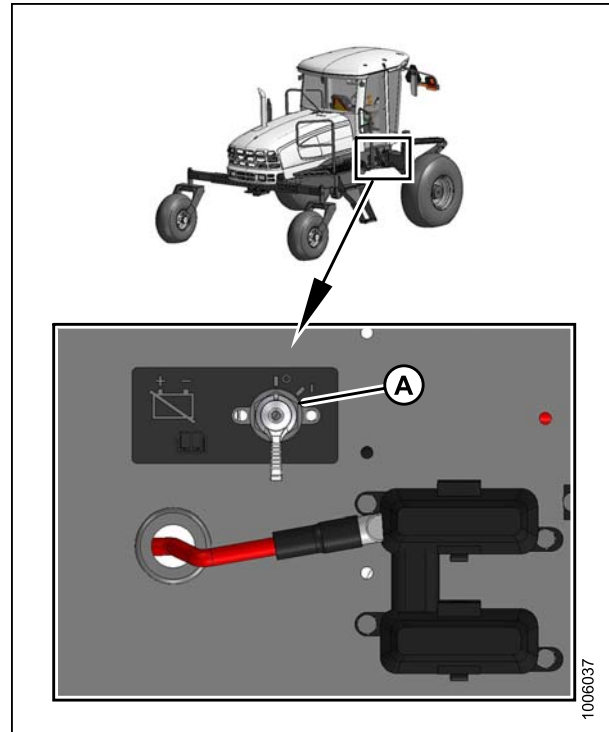

Figure 5.18: Battery Switch

5.12.1 Checking Engine Warning Lights

1. Turn ignition key (A) to RUN position. A single loud tone will be audible and the engine warning lights (B) will illuminate.
2. Turn ignition key (A) to OFF position.

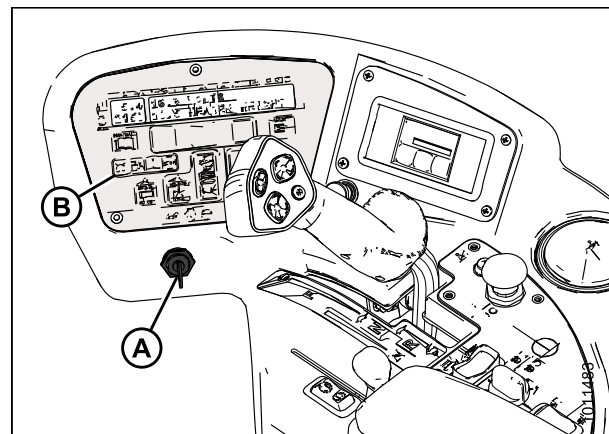

Figure 5.19: Operator Console

5.12.2 Checking Windrower Startup

CAUTION

Check to be sure all bystanders have cleared the area.

1. Start the engine. For instructions, refer to [3.6 Starting Engine, page 19](#).

NOTE:

The brakes should engage and the machine should not move after engine start-up.

2. Ensure the steering wheel is centered. Move ground speed lever (GSL) (A) straight out of N-DETENT (neither forward nor reverse). The machine should not move.
3. Check that the steering wheel is free to move.

IMPORTANT:

If the machine does not function as described, the system requires adjustment. Refer to the windrower technical manual.

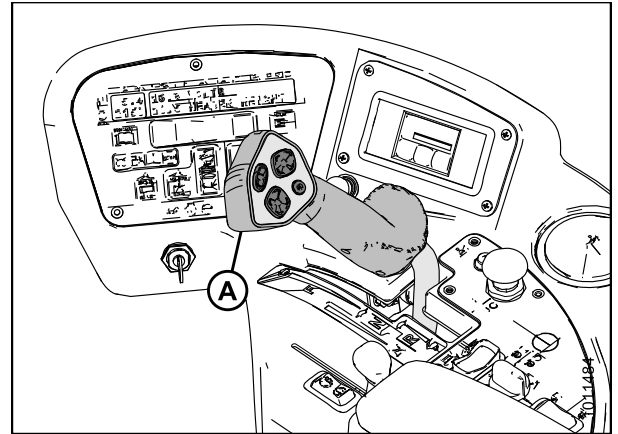

Figure 5.20: Operator Console

5.12.3 Checking Engine Speed

1. Move throttle to idle position.
2. Check engine speed on cab display module (CDM) (A) and compare to value in table.
3. Move throttle to maximum rpm position.
4. Check engine speed on cab display module (CDM) (A) and compare to value in table.

Table 5.4 Engine Speed

Idle rpm	Maximum rpm (No Load)
1000 +/- 30 rpm	2300 +/- 30 rpm

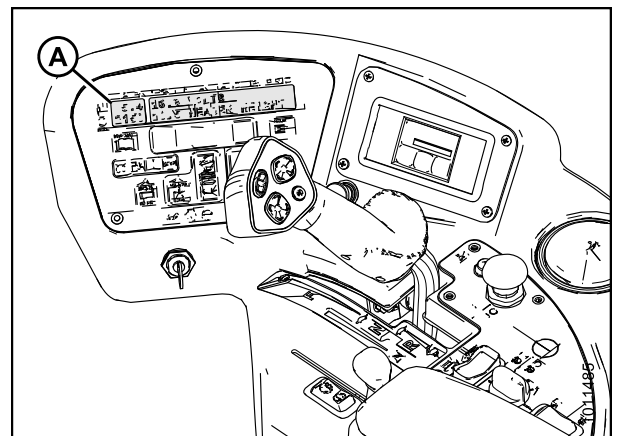

Figure 5.21: Cab Display Module (CDM)

5.12.4 Checking Gauges and Cab Display Module (CDM) Display

1. Check that fuel and diesel exhaust fluid (DEF) gauges are working by pressing and holding the fuel gauge icon (A) for 2 seconds—the brightness symbol and backlight function becomes active. The fuel gauge icon will reappear if nothing is pressed for 5 seconds.



Figure 5.22: Fuel and DEF Gauges

2. Ensure the CDM display (A) is working by pushing the SELECT (B) button on the CDM or the SELECT (C) button on the ground speed lever (GSL).

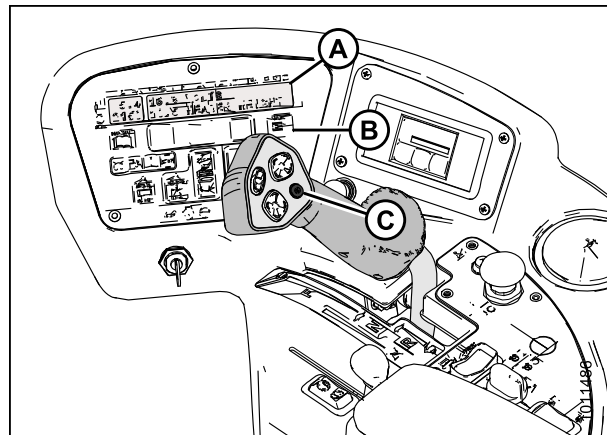

Figure 5.23: Operator Console

5.12.5 Checking Electrical System

1. Push the SELECT button (C) on the ground speed lever (GSL) or the SELECT button (B) on the cab display module (CDM) until the CDM display (A) displays VOLTS. The display indicates the condition of the battery and alternator. Refer to [Table 5.5 Battery and Alternator Condition, page 149](#).

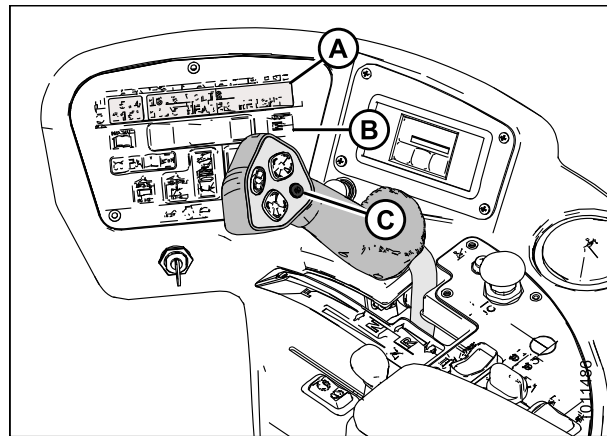

Figure 5.24: Operator Console

PERFORMING PREDELIVERY CHECKS

Table 5.5 Battery and Alternator Condition

Ignition	Engine	Reading	Indicated Condition
ON	Running	13.8–15.0	Normal
		>16.0 (see note)	Regulator out of adjustment
		<12.5 (see note)	Alternator not working or Regulator out of adjustment
	Shut down	12.0	Battery normal

NOTE:

Display flashes voltage reading accompanied by a single loud tone every 30 minutes until condition is fixed.

5.12.6 Checking Operator's Presence System

CAUTION

Check to be sure all bystanders have cleared the area.

1. Start the engine.
2. Place the ground speed lever (GSL) (A) in NEUTRAL and turn the steering wheel until it locks.
3. Engage header drive switch (B).
4. Stand up from the operator's seat. The header should shut off after approximately 5 seconds. If the header does not shut off, the Operator Presence System requires adjustment. Refer to the technical manual.

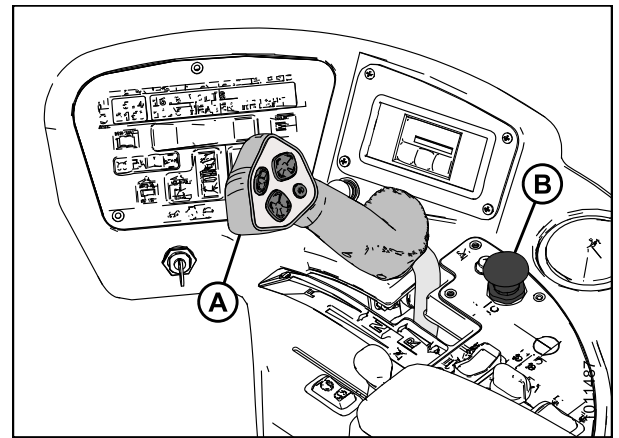

Figure 5.25: Operator Console

NOTE:

To restart the header, move the header drive switch (B) to the OFF position and then back to the ON position.

5. Start the engine and position the GSL in NEUTRAL and N-DETENT:
 - a. Swivel the operator's station but do **NOT** lock into position.
 - b. Move the GSL out of N-DETENT. The engine should shut down and the lower display will flash LOCK SEAT BASE → CENTER STEERING WHEEL → NOT IN NEUTRAL.
 - c. Swivel and lock the operator's station and the display should return to normal.
 - d. If the engine does not shut down, the seat position switches require adjustment. Refer to the technical manual.
6. Start the engine and drive the windrower at a speed **less than** 8 km/h (5 mph):
 - a. Stand up from the operator's seat.
 - b. Ensure the CDM flashes NO OPERATOR on the upper line and ENGINE SHUTDOWN 5...4...3...2...1...0 on the lower line accompanied by a steady tone. When the CDM display reaches 0, the engine will shut down.

PERFORMING PREDELIVERY CHECKS

- c. If the engine does not shut down, the Operator Presence System requires adjustment. Refer to the technical manual.
7. Start the engine and drive the windrower at a speed **more than** 8 km/h (5 mph):
- a. Stand up from the operator's seat.
 - b. The CDM beeps once and displays NO OPERATOR on the lower line.
 - c. If the CDM does not beep and display message, the Operator Presence System requires adjustment. Refer to the technical manual.

5.12.7 Checking Exterior Lights

1. Rotate the operator's seat to cab-forward mode.
2. Turn field light switch (A) to the ON position and ensure the front field lights (B) and rear swath lights (C) are functioning.

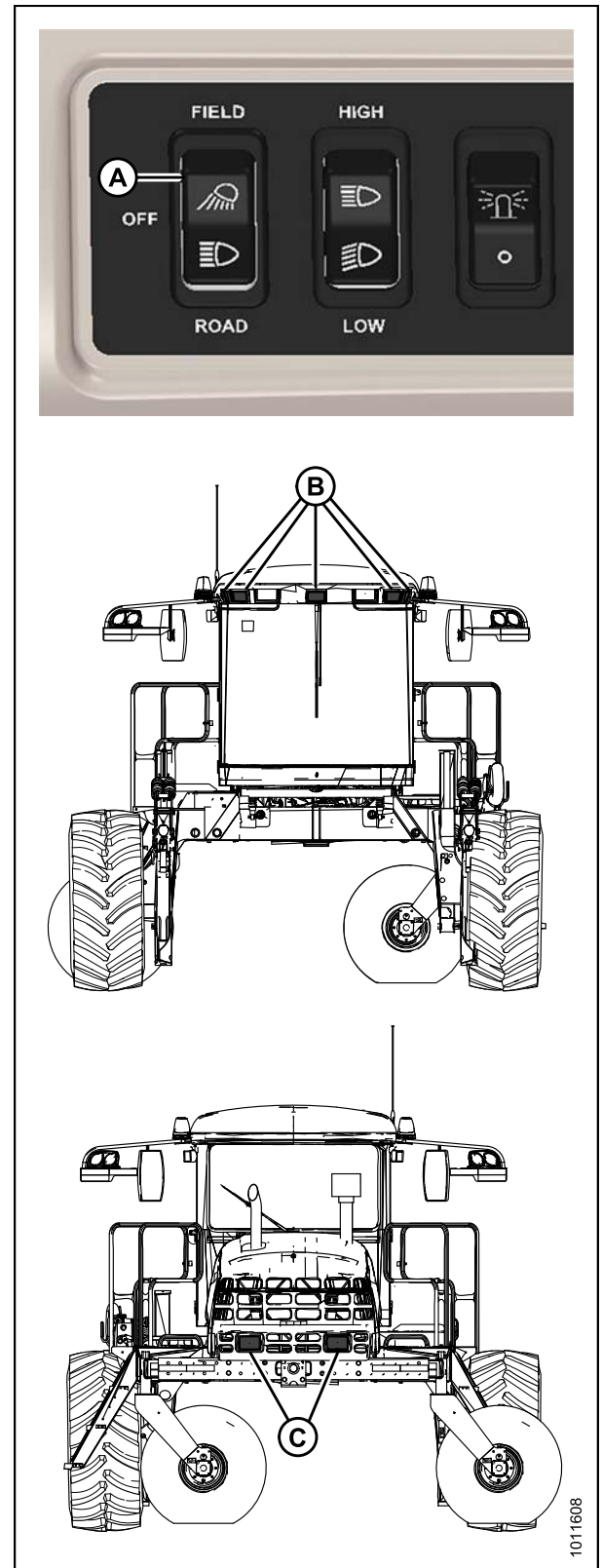

Figure 5.26: Exterior Lights – Cab Forward

PERFORMING PREDELIVERY CHECKS

3. Turn the road light switch (A) to the ON position and ensure the front road lights (B) and rear red tail/brake lights (C) (if equipped) are functioning.
4. Activate the high/low switch (D) and check lights.
5. Activate the amber turn signal/hazard warning lights (E) using switches on the cab display module (CDM) and check lights.

IMPORTANT:

Optional red tail lighting and marking kit must be installed so that road travel in the cab-forward mode complies with road travel regulations. See your MacDon Dealer. If you do not have the optional tail light kit installed, you will be prompted with LH or RH stop lamp (E134 or E135) warning displayed in the cab display module (CDM) with engine running and cab-forward mode.

6. Turn OFF lights.

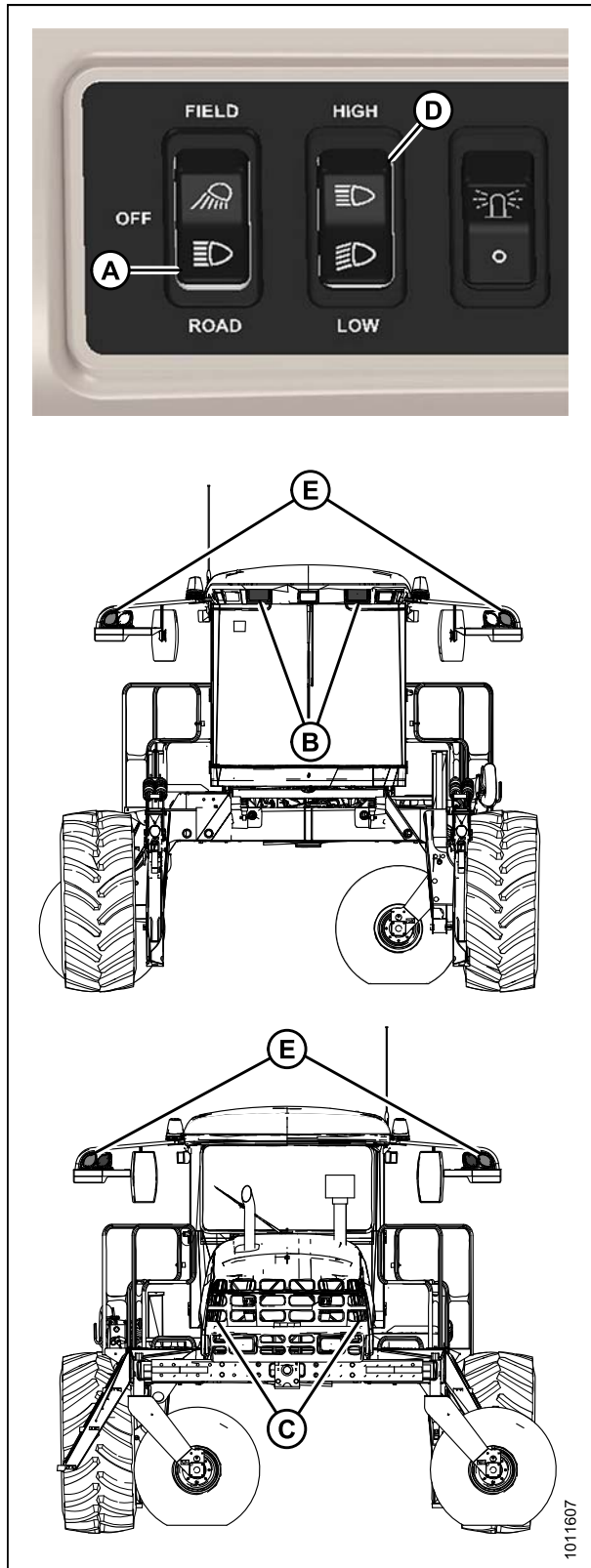

Figure 5.27: Exterior Lights – Cab Forward

PERFORMING PREDELIVERY CHECKS

7. Turn beacon switch (A) to the ON position and ensure the amber beacons (B) are functioning.

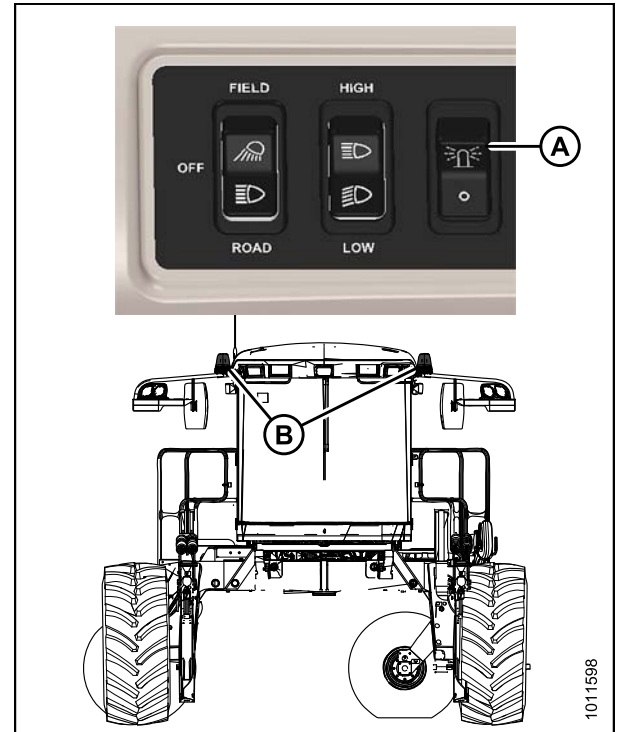

Figure 5.28: Exterior Lights – Beacons

Auto Road Light

The beacon and hazard lights are included in the auto road light feature. The beacon and hazard lights will turn on when this feature is activated, and can only be turned off by engaging the header drive.

This feature will activate when:

- Windrower is in cab- or engine-forward mode
- Engine is running
- Header is disengaged
- Transmission is in either mid or high range

Moving the ground speed lever (GSL) out of neutral (brake off) will switch the white lights from field/work lights to road lights, if the switch is in the field/road lights position.

PERFORMING PREDELIVERY CHECKS

5.12.8 Checking Horn

1. Push HORN button (A) and listen for horn.

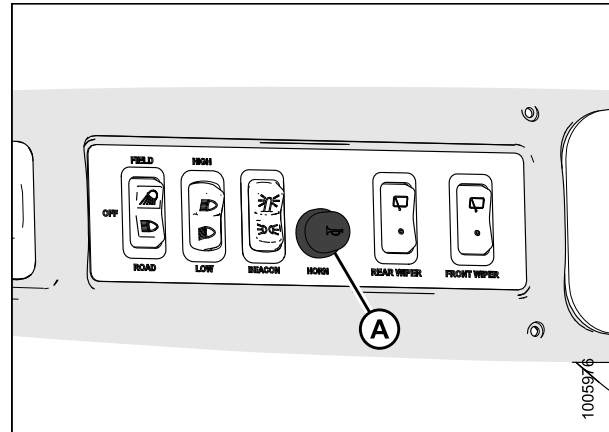

Figure 5.29: Horn Button

5.12.9 Checking Interior Lights

1. Switch road and field lights ON and OFF using switch (A).

NOTE:

Ambient light in roof liner (B) and interior light (C) work only when road or field lights (A) are switched ON.

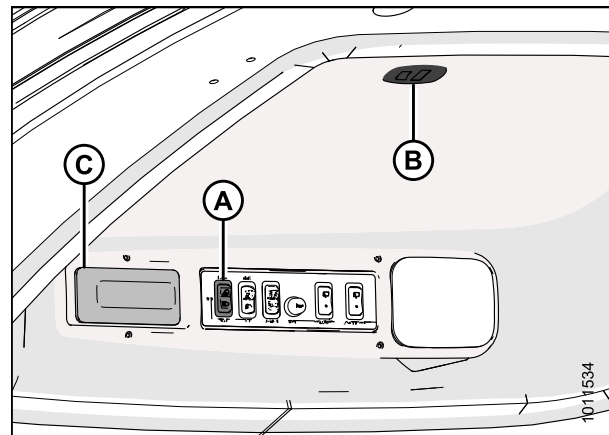

Figure 5.30: Interior Lights

5.12.10 Checking Air Conditioning (A/C) and Heater



Figure 5.31: A/C and Heater Controls

- **Blower switch (A):** Controls blower speed. Switch settings are OFF, LO, MEDIUM, and HI.
- **Air conditioning switch (B):** Controls A/C system. When set to ON, A/C operates if blower switch (A) is switched ON. When set to OFF, the A/C system does not operate.
- **Outside air switch (C):** Controls air source. When set to FRESH AIR, booster fan starts and draws filtered outside air into the cab. When set to RECIRCULATED, booster fan stops and air inside cab is recirculated.
- **Temperature control (D):** Controls cab temperature. Turn knob clockwise to increase temperature, and turn knob counterclockwise to decrease temperature.

IMPORTANT:

To distribute oil throughout the A/C system, perform the following steps after starting a machine that has been stored for more than one week:

1. Start engine and turn blower switch (A) to the first position, turn temperature control (D) to maximum heating, and turn A/C switch (B) to OFF.
2. Turn A/C switch (B) from OFF to ON position for 1 second, then back to OFF for 5 to 10 seconds. Repeat this step ten times.

PERFORMING PREDELIVERY CHECKS

5.13 Checking Manuals

Manuals are stored in the manual storage case (A) behind the operator's seat.

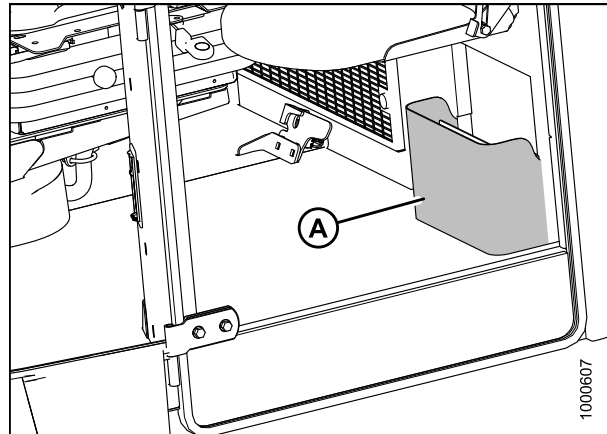

Figure 5.32: Manual Storage Case

1. Ensure the following manuals are included with the windrower:

- Operator's Manual
- Parts Catalog
- Quick Card
- Engine Manual

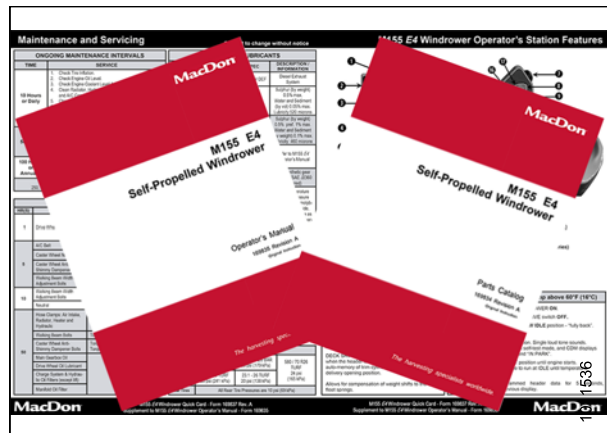

Figure 5.33: Manuals and Quick Card

5.14 Performing Final Steps

1. Remove plastic covering from cab display module (CDM), and seats after predelivery checks are complete.
2. Locate bag inside the cab containing the GPS mount kit, and install kit in accordance with the instructions in the kit. If not installing kit, label bag (GPS Completion Kit) and place kit in toolbox for safekeeping.
3. Remove decal (MD #166705) from windshield only **AFTER** machine is delivered to the end user.

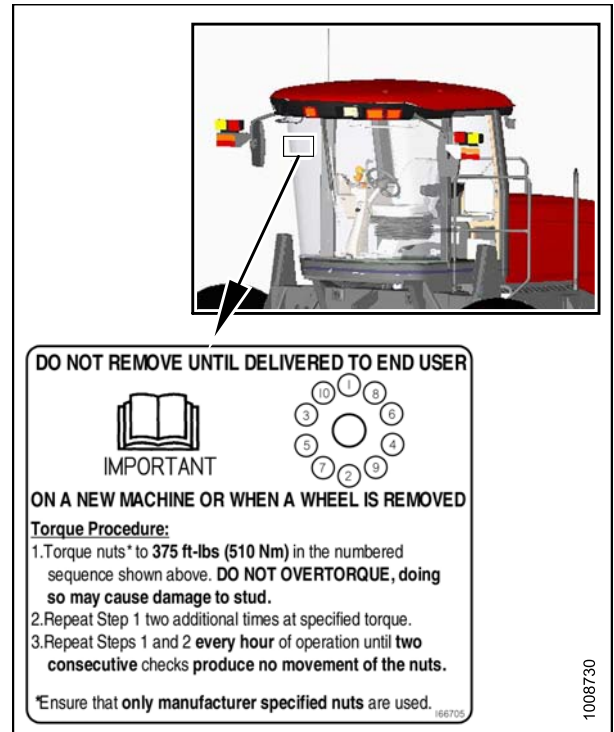

Figure 5.34: Windshield Decal (MD #166705)

6 Reference

6.1 Torque Specifications

The following tables provide the correct torque values for various bolts, cap screws, and hydraulic fittings.

- Tighten all bolts to torque values specified in charts (unless otherwise noted throughout this manual).
- Replace hardware with same strength and grade of bolt.
- Use torque value tables as a guide and periodically check tightness of bolts.
- Understand torque categories for bolts and cap screws by using their identifying head markings.

6.1.1 SAE Bolt Torque Specifications

Torque values shown in the following tables are valid for non-greased, or non-oiled threads and heads; therefore, do **NOT** grease or oil bolts or cap screws unless otherwise specified in this manual.

Table 6.1 SAE Grade 5 Bolt and Grade 5 Free Spinning Nut

Nominal Size (A)	Torque (N·m)		Torque (ft·lbf) (*in·lbf)	
	Min.	Max.	Min.	Max.
1/4-20	11.9	13.2	*106	*117
5/16-18	24.6	27.1	*218	*241
3/8-16	44	48	32	36
7/16-14	70	77	52	57
1/2-13	106	118	79	87
9/16-12	153	170	114	126
5/8-11	212	234	157	173
3/4-10	380	420	281	311
7/8-9	606	669	449	496
1-8	825	912	611	676

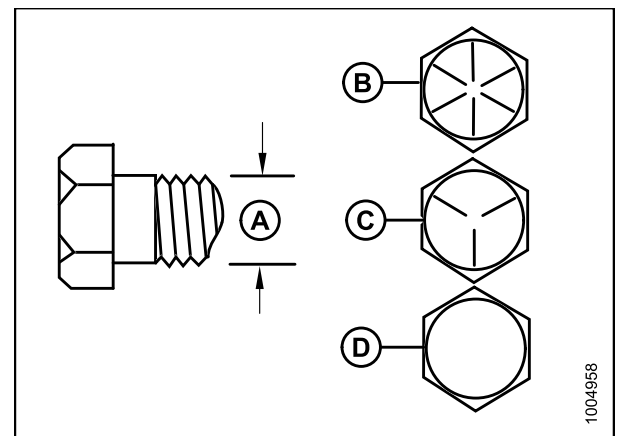

Figure 6.1: Bolt Grades

A - Nominal Size
C - SAE-5

B - SAE-8
D - SAE-2

1004958

REFERENCE

Table 6.2 SAE Grade 5 Bolt and Grade F Distorted Thread Nut

Nominal Size (A)	Torque (N·m)		Torque (ft·lbf) (*in·lbf)	
	Min.	Max.	Min.	Max.
1/4-20	8.1	9	*72	*80
5/16-18	16.7	18.5	*149	*164
3/8-16	30	33	22	24
7/16-14	48	53	35	39
1/2-13	73	80	54	59
9/16-12	105	116	77	86
5/8-11	144	160	107	118
3/4-10	259	286	192	212
7/8-9	413	456	306	338
1-8	619	684	459	507

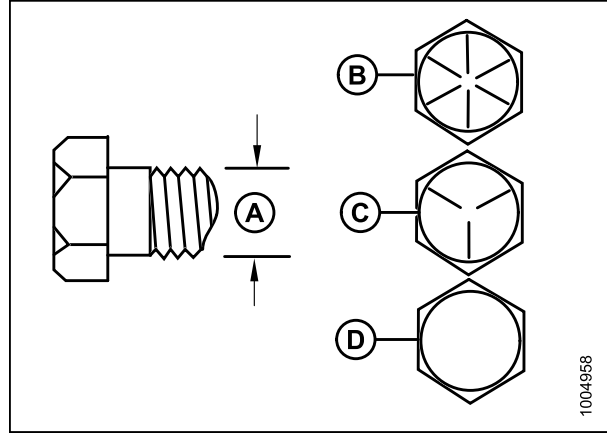

Figure 6.2: Bolt Grades

A - Nominal Size
 B - SAE-8
 C - SAE-5
 D - SAE-2

Table 6.3 SAE Grade 8 Bolt and Grade G Distorted Thread Nut

Nominal Size (A)	Torque (N·m)		Torque (ft·lbf) (*in·lbf)	
	Min.	Max.	Min.	Max.
1/4-20	16.8	18.6	*150	*165
5/16-18	24	26	18	19
3/8-16	42	46	31	34
7/16-14	67	74	50	55
1/2-13	102	113	76	84
9/16-12	148	163	109	121
5/8-11	204	225	151	167
3/4-10	362	400	268	296
7/8-9	583	644	432	477
1-8	874	966	647	716

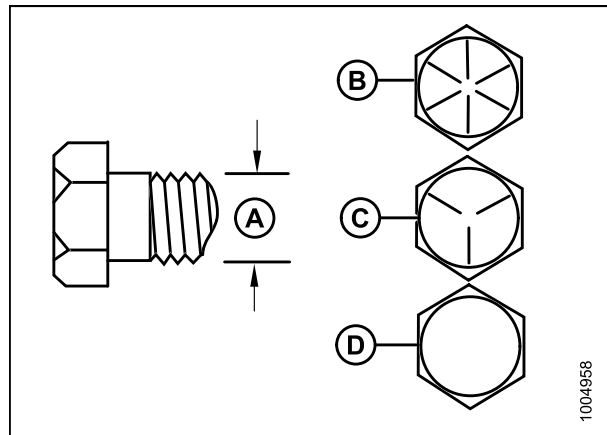

Figure 6.3: Bolt Grades

A - Nominal Size
 B - SAE-8
 C - SAE-5
 D - SAE-2

REFERENCE

Table 6.4 SAE Grade 8 Bolt and Grade 8 Free Spinning Nut

Nominal Size (A)	Torque (N-m)		Torque (ft-lbf) (*in-lbf)	
	Min.	Max.	Min.	Max.
1/4-20	16.8	18.6	*150	*165
5/16-18	35	38	26	28
3/8-16	61	68	46	50
7/16-14	98	109	73	81
1/2-13	150	166	111	123
9/16-12	217	239	160	177
5/8-11	299	330	221	345
3/4-10	531	587	393	435
7/8-9	855	945	633	700
1-8	1165	1288	863	954

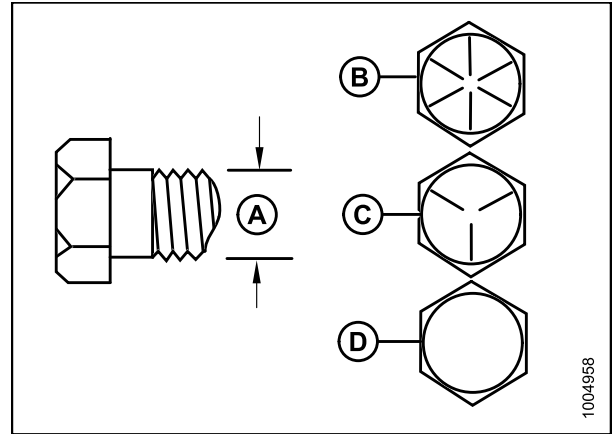

Figure 6.4: Bolt Grades

A - Nominal Size
C - SAE-5

B - SAE-8
D - SAE-2

6.1.2 Metric Bolt Specifications

Table 6.5 Metric Class 8.8 Bolts and Class 9 Free Spinning Nut

Nominal Size (A)	Torque (N-m)		Torque (ft-lbf) (*in-lbf)	
	Min.	Max.	Min.	Max.
3-0.5	1.4	1.6	*13	*14
3.5-0.6	2.2	2.5	*20	*22
4-0.7	3.3	3.7	*29	*32
5-0.8	6.7	7.4	*59	*66
6-1.0	11.4	12.6	*101	*112
8-1.25	28	30	20	23
10-1.5	55	60	40	45
12-1.75	95	105	70	78
14-2.0	152	168	113	124
16-2.0	236	261	175	193
20-2.5	460	509	341	377
24-3.0	796	879	589	651

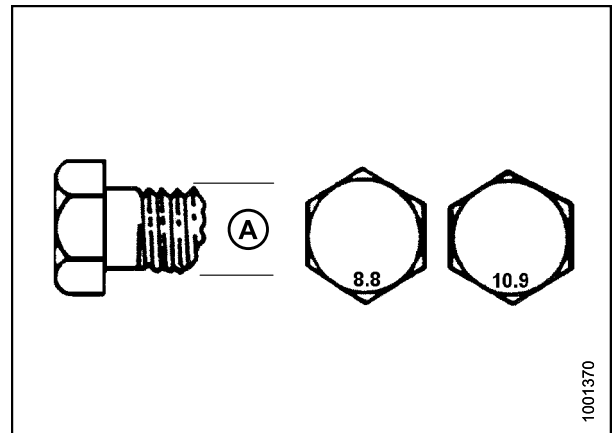

Figure 6.5: Bolt Grades

REFERENCE

Table 6.6 Metric Class 8.8 Bolts and Class 9 Distorted Thread Nut

Nominal Size (A)	Torque (N·m)		Torque (ft·lbf) (*in·lbf)	
	Min.	Max.	Min.	Max.
3-0.5	1	1.1	*9	*10
3.5-0.6	1.5	1.7	*14	*15
4-0.7	2.3	2.5	*20	*22
5-0.8	4.5	5	*40	*45
6-1.0	7.7	8.6	*69	*76
8-1.25	18.8	20.8	*167	*185
10-1.5	37	41	28	30
12-1.75	65	72	48	53
14-2.0	104	115	77	85
16-2.0	161	178	119	132
20-2.5	314	347	233	257
24-3.0	543	600	402	444

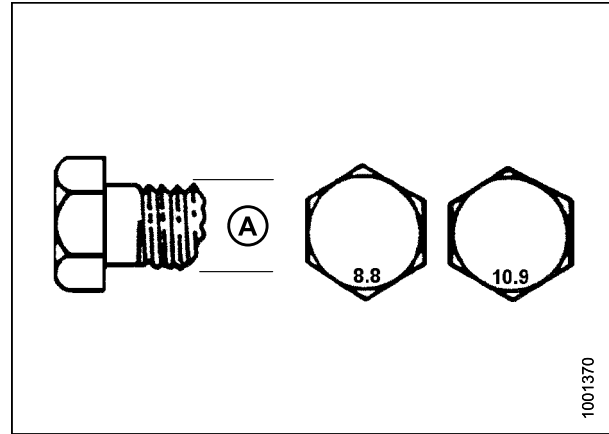

Figure 6.6: Bolt Grades

Table 6.7 Metric Class 10.9 Bolts and Class 10 Free Spinning Nut

Nominal Size (A)	Torque (N·m)		Torque (ft·lbf) (*in·lbf)	
	Min.	Max.	Min.	Max.
3-0.5	1.8	2	*18	*19
3.5-0.6	2.8	3.1	*27	*30
4-0.7	4.2	4.6	*41	*45
5-0.8	8.4	9.3	*82	*91
6-1.0	14.3	15.8	*140	*154
8-1.25	38	42	28	31
10-1.5	75	83	56	62
12-1.75	132	145	97	108
14-2.0	210	232	156	172
16-2.0	326	360	242	267
20-2.5	637	704	472	521
24-3.0	1101	1217	815	901

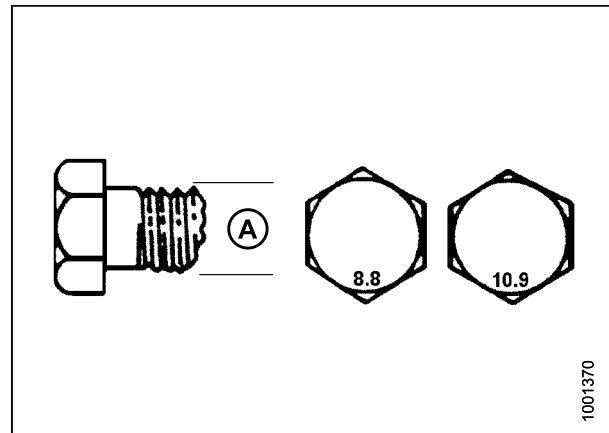

Figure 6.7: Bolt Grades

REFERENCE

Table 6.8 Metric Class 10.9 Bolts and Class 10 Distorted Thread Nut

Nominal Size (A)	Torque (N·m)		Torque (ft·lbf) (*in·lbf)	
	Min.	Max.	Min.	Max.
3-0.5	1.3	1.5	*12	*13
3.5-0.6	2.1	2.3	*19	*21
4-0.7	3.1	3.4	*28	*31
5-0.8	6.3	7	*56	*62
6-1.0	10.7	11.8	*95	*105
8-1.25	26	29	19	21
10-1.5	51	57	38	42
12-1.75	90	99	66	73
14-2.0	143	158	106	117
16-2.0	222	246	165	182
20-2.5	434	480	322	356
24-3.0	750	829	556	614

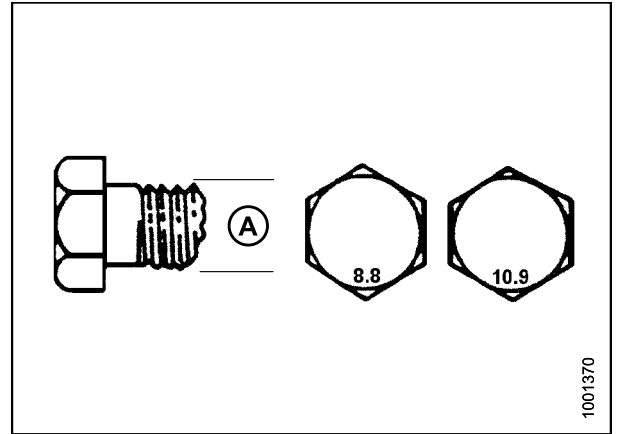

Figure 6.8: Bolt Grades

6.1.3 Metric Bolt Specifications Bolting into Cast Aluminum

Table 6.9 Metric Bolt Bolting into Cast Aluminum

Nominal Size (A)	Bolt Torque			
	8.8 (Cast Aluminum)		10.9 (Cast Aluminum)	
	N·m	ft·lbf	N·m	ft·lbf
M3	–	–	–	1
M4	–	–	4	2.6
M5	–	–	8	5.5
M6	9	6	12	9
M8	20	14	28	20
M10	40	28	55	40
M12	70	52	100	73
M14	–	–	–	–
M16	–	–	–	–

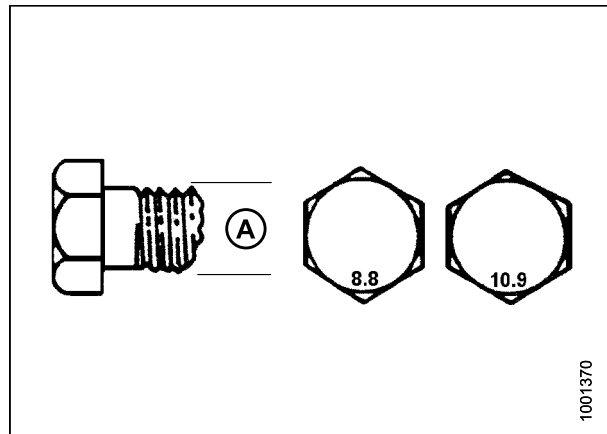

Figure 6.9: Bolt Grades

6.1.4 Flare-Type Hydraulic Fittings

1. Check flare (A) and flare seat (B) for defects that might cause leakage.
2. Align tube (C) with fitting (D) and thread nut (E) onto fitting without lubrication until contact has been made between flared surfaces.
3. Torque fitting nut (E) to specified number of flats from finger tight (FFFT) or to a given torque value in [Table 6.10 Flare-Type Hydraulic Tube Fittings, page 165](#).
4. Use two wrenches to prevent fitting (D) from rotating. Place one wrench on fitting body (D), and tighten nut (E) with other wrench to torque shown.
5. Assess final condition of connection.

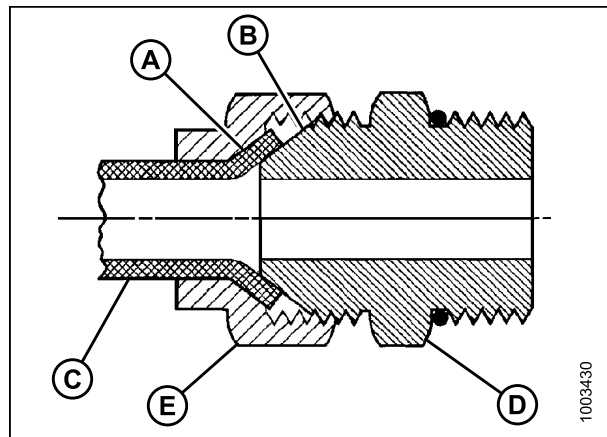

Figure 6.10: Hydraulic Fitting

REFERENCE

Table 6.10 Flare-Type Hydraulic Tube Fittings

SAE Dash Size	Thread Size (in.)	Torque Value ¹⁰		Flats from Finger Tight (FFFT)	
		N-m	ft-lbf	Tube	Swivel Nut or Hose
-2	5/16-24	4-5	3-4	—	—
-3	3/8-24	7-8	5-6	—	—
-4	7/16-20	18-19	13-14	2-1/2	2
-5	1/2-20	19-21	14-15	2	2
-6	9/16-18	30-33	22-24	2	1-1/2
-8	3/4-16	57-63	42-46	2	1-1/2
-10	7/8-14	81-89	60-66	1-1/2	1-1/2
-12	1-1/16-12	113-124	83-91	1-1/2	1-1/4
-14	1-3/16-12	136-149	100-110	1-1/2	1-1/4
-16	1-5/16-12	160-176	118-130	1-1/2	1
-20	1-5/8-12	228-250	168-184	1	1
-24	1-7/8-12	264-291	195-215	1	1
-32	2-1/2-12	359-395	265-291	1	1
-40	3-12	—	—	1	1

10. Torque values shown are based on lubricated connections as in reassembly.

REFERENCE

6.1.5 O-Ring Boss (ORB) Hydraulic Fittings (Adjustable)

1. Inspect O-ring (A) and seat (B) for dirt or obvious defects.
2. Back off lock nut (C) as far as possible. Ensure that washer (D) is loose and is pushed toward lock nut (C) as far as possible.
3. Check that O-ring (A) is **NOT** on threads and adjust if necessary.
4. Apply hydraulic system oil to O-ring (A).

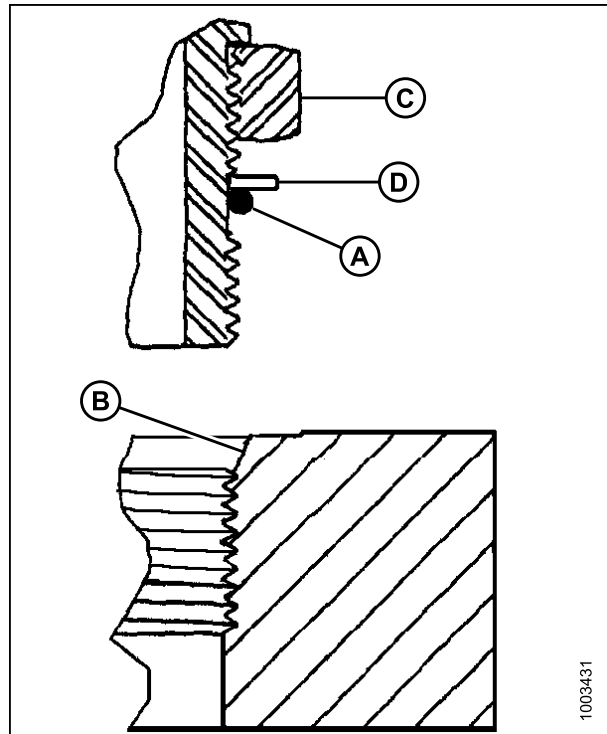

Figure 6.11: Hydraulic Fitting

5. Install fitting (B) into port until back up washer (D) and O-ring (A) contact part face (E).
6. Position angle fittings by unscrewing no more than one turn.
7. Turn lock nut (C) down to washer (D) and tighten to torque shown. Use two wrenches, one on fitting (B) and other on lock nut (C).
8. Check final condition of fitting.

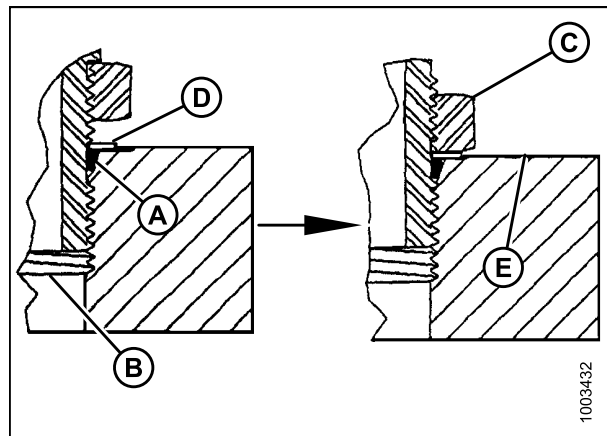

Figure 6.12: Hydraulic Fitting

REFERENCE

Table 6.11 O-Ring Boss (ORB) Hydraulic Fittings (Adjustable)

SAE Dash Size	Thread Size (in.)	Torque Value ¹¹	
		N-m	ft·lbf (*in·lbf)
-2	5/16-24	6-7	*53-62
-3	3/8-24	12-13	*106-115
-4	7/16-20	19-21	14-15
-5	1/2-20	21-33	15-24
-6	9/16-18	26-29	19-21
-8	3/4-16	46-50	34-37
-10	7/8-14	75-82	55-60
-12	1-1/16-12	120-132	88-97
-14	1-3/8-12	153-168	113-124
-16	1-5/16-12	176-193	130-142
-20	1-5/8-12	221-243	163-179
-24	1-7/8-12	270-298	199-220
-32	2-1/2-12	332-365	245-269

11. Torque values shown are based on lubricated connections as in reassembly.

REFERENCE

6.1.6 O-Ring Boss (ORB) Hydraulic Fittings (Non-Adjustable)

1. Inspect O-ring (A) and seat (B) for dirt or obvious defects.
2. Check that O-ring (A) is **NOT** on threads and adjust if necessary.
3. Apply hydraulic system oil to O-ring.
4. Install fitting (C) into port until fitting is hand tight.
5. Torque fitting (C) according to values in Table 6.12 *O-Ring Boss (ORB) Hydraulic Fittings (Non-Adjustable)*, page 168.
6. Check final condition of fitting.

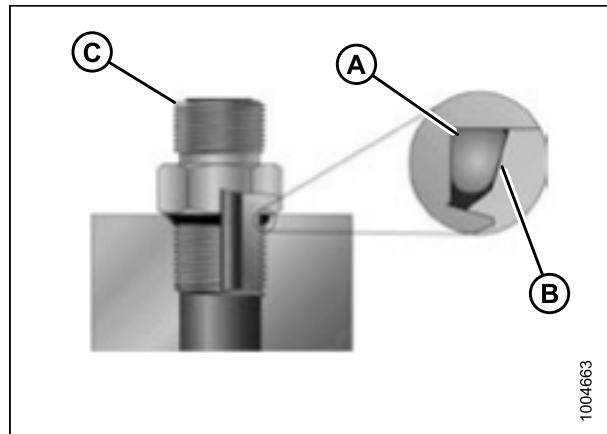

Figure 6.13: Hydraulic Fitting

Table 6.12 O-Ring Boss (ORB) Hydraulic Fittings (Non-Adjustable)

SAE Dash Size	Thread Size (in.)	Torque Value ¹²	
		N-m	ft·lbf (*in·lbf)
-2	5/16-24	6-7	*53-62
-3	3/8-24	12-13	*106-115
-4	7/16-20	19-21	14-15
-5	1/2-20	21-33	15-24
-6	9/16-18	26-29	19-21
-8	3/4-16	46-50	34-37
-10	7/8-14	75-82	55-60
-12	1-1/16-12	120-132	88-97
-14	1-3/8-12	153-168	113-124
-16	1-5/16-12	176-193	130-142
-20	1-5/8-12	221-243	163-179
-24	1-7/8-12	270-298	199-220
-32	2-1/2-12	332-365	245-269

12. Torque values shown are based on lubricated connections as in reassembly.

6.1.7 O-Ring Face Seal (ORFS) Hydraulic Fittings

1. Check components to ensure that sealing surfaces and fitting threads are free of burrs, nicks, scratches, or any foreign material.



Figure 6.14: Hydraulic Fitting

2. Apply hydraulic system oil to O-ring (B).
3. Align tube or hose assembly so that flat face of sleeve (A) or (C) comes in full contact with O-ring (B).
4. Thread tube or hose nut (D) until hand-tight. The nut should turn freely until it is bottomed out.
5. Torque fittings according to values in Table 6.13 *O-Ring Face Seal (ORFS) Hydraulic Fittings*, page 170.

NOTE:

If applicable, hold hex on fitting body (E) to prevent rotation of fitting body and hose when tightening fitting nut (D).

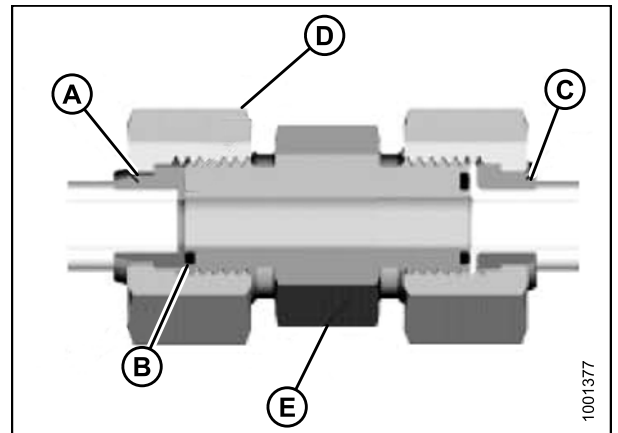

Figure 6.15: Hydraulic Fitting

6. Use three wrenches when assembling unions or joining two hoses together.
7. Check final condition of fitting.

REFERENCE

Table 6.13 O-Ring Face Seal (ORFS) Hydraulic Fittings

SAE Dash Size	Thread Size (in.)	Tube O.D. (in.)	Torque Value ¹³	
			N·m	ft·lbf
-3	Note ¹⁴	3/16	–	–
-4	9/16	1/4	25–28	18–21
-5	Note ¹⁴	5/16	–	–
-6	11/16	3/8	40–44	29–32
-8	13/16	1/2	55–61	41–45
-10	1	5/8	80–88	59–65
-12	1-3/16	3/4	115–127	85–94
-14	Note ¹⁴	7/8	–	–
-16	1-7/16	1	150–165	111–122
-20	1-11/16	1-1/4	205–226	151–167
-24	1–2	1-1/2	315–347	232–256
-32	2-1/2	2	510–561	376–414

13. Torque values and angles shown are based on lubricated connection as in reassembly.

14. O-ring face seal type end not defined for this tube size.

6.1.8 Tapered Pipe Thread Fittings

Assemble pipe fittings as follows:

1. Check components to ensure that fitting and port threads are free of burrs, nicks and scratches, or any form of contamination.
2. Apply pipe thread sealant (paste type) to external pipe threads.
3. Thread fitting into port until hand-tight.
4. Torque connector to appropriate torque angle. The Turns From Finger Tight (TFFT) values are shown in Table [6.14 Hydraulic Fitting Pipe Thread, page 171](#). Make sure that tube end of a shaped connector (typically 45° or 90°) is aligned to receive incoming tube or hose assembly. Always finish alignment of fitting in tightening direction. Never back off (loosen) pipe threaded connectors to achieve alignment
5. Clean all residue and any excess thread conditioner with appropriate cleaner.
6. Assess final condition of fitting. Pay special attention to possibility of cracks to port opening.
7. Mark final position of fitting. If a fitting leaks, disassemble fitting and check for damage.

NOTE:

*Over-torque failure of fittings may not be evident until fittings are disassembled.

Table 6.14 Hydraulic Fitting Pipe Thread

Tapered Pipe Thread Size	Recommended T.F.F.T	Recommended F.F.F.T
1/8-27	2-3	12-18
1/4-18	2-3	12-18
3/8-18	2-3	12-18
1/2-14	2-3	12-18
3/4-14	1.5-2.5	12-18
1-11 1/2	1.5-2.5	9-15
1 1/4-11 1/2	1.5-2.5	9-15
1 1/2-11 1/2	1.5-2.5	9-15
2-11 1/2	1.5-2.5	9-15

REFERENCE

6.2 Conversion Chart

Table 6.15 Conversion Chart

Quantity	SI Units (Metric)		Factor	Inch-Pound Units	
	Unit Name	Abbreviation		Unit Name	Abbreviation
Area	hectares	ha	$\times 0.4047 =$	acres	acres
Flow	liters per minute	L/min	$\times 3.7854 =$	US gallons per minute	gpm
Force	Newtons	N	$\times 4.4482 =$	pounds force	lbf
Length	millimeters	mm	$\times 25.4 =$	inch	in.
	meters	m	$\times 0.305 =$	foot	ft.
Power	kilowatts	kW	$\times 0.7457 =$	horsepower	hp
Pressure	kilopascals	kPa	$\times 6.8948 =$	pounds per square inch	psi
	megapascals	MPa	$\times .00689 =$		
	bar (Non-SI)	bar	$\div 14.5038 =$		
Torque	Newton meters	N·m	$\times 1.3558 =$	pound feet or foot pounds	ft·lbf
	Newton meters	N·m	$\times 0.1129 =$	pound inches or inch pounds	in·lbf
Temperature	Celsius	°C	$(^{\circ}\text{F}-32) \times 0.56 =$	degrees Fahrenheit	°F
Velocity	meters per minute	m/min	$\times 0.3048 =$	feet per minute	ft/min
	meters per second	m/s	$\times 0.3048 =$	feet per second	ft/s
	kilometers per hour	km/h	$\times 1.6063 =$	miles per hour	mph
Volume	liters	L	$\times 3.7854 =$	US gallons	US gal
	milliliters	ml	$\times 29.5735 =$	ounces	oz.
	cubic centimeters	cm ³ or cc	$\times 16.3871 =$	cubic inches	in. ³
Weight	kilograms	kg	$\times 0.4536 =$	pounds	lb.

REFERENCE

6.3 Definitions

The following terms and acronyms may be used in this manual.

Term	Definition
A-Series header	MacDon A30-D and A40-D auger headers
API	American Petroleum Institute
ASTM	American Society of Testing and Materials
Bolt	A headed and externally threaded fastener that is designed to be paired with a nut
Cab-forward	Windrower operation with Operator and cab facing in direction of travel
CDM	Cab display module on a self-propelled windrower
Center-link	A hydraulic cylinder link between header and machine to which it is attached: It is used to change header angle
CGVW	Combined vehicle gross weight
D-Series header	MacDon D50, D60, and D65 rigid draper headers
DEF	Diesel exhaust fluid; also called AdBlue in Europe, and AUS 32 in Australia
DEF supply module	Pumps diesel exhaust fluid through system
DM	Dosing module
DK	Double knife
DKD	Double-knife drive
DDD	Double-draper drive
DOC	Diesel oxidation catalyst
DRT	Decomposition reactor tube
DWA	Double Windrow Attachment
ECM	Engine control module
ECU	Electronic control unit
Engine-forward	Windrower operation with Operator and engine facing in direction of travel
Finger tight	Finger tight is a reference position where sealing surfaces or components are making contact with each other and fitting has been tightened to a point where fitting is no longer loose
FFFT	Flats from finger tight
GSL	Ground speed lever
GSS	Grass Seed Special
GVW	Gross vehicle weight
Hard joint	A joint made with the use of a fastener where joining materials are highly incompressible
Header	A machine that cuts and lays crop into a windrow and is attached to a self-propelled windrower

REFERENCE

Term	Definition
Hex key	A hex key or Allen key (also known by various other synonyms) is a tool of hexagonal cross-section used to drive bolts and screws that have a hexagonal socket in head (internal-wrenching hexagon drive)
HDS	Hydraulic deck shift
hp	Horsepower
ISC	Intermediate Speed Control
JIC	Joint Industrial Council: A standards body that developed standard sizing and shape for original 37° flared fitting
Knife	A cutting device which uses a reciprocating cutter (also called a sickle)
MDS	Mechanical deck shift
n/a	Not applicable
Nut	An internally threaded fastener that is designed to be paired with a bolt
N-DETENT	The slot opposite the NEUTRAL position on operator's console
NPT	National Pipe Thread: A style of fitting used for low pressure port openings Threads on NPT fittings are uniquely tapered for an interference fit
ORB	O-ring boss: A style of fitting commonly used in port opening on manifolds, pumps, and motors
ORFS	O-ring face seal: A style of fitting commonly used for connecting hoses and tubes This style of fitting is also commonly called ORS, which stands for O-ring seal
rpm	Revolutions per minute
R-Series header	MacDon R80 and R85 rotary disc headers
RoHS (Reduction of Hazardous Substances)	A directive by the European Union to restrict use of certain hazardous substances (such as hexavalent chromium used in some yellow zinc platings)
SAE	Society of Automotive Engineers
SCR	Selective catalytic reduction
Screw	A headed and externally threaded fastener that threads into preformed threads or forms its own thread in one of mating parts
SDD	Single-drapeer drive
Self-Propelled (SP) Windrower	Self-propelled machine consisting of a power unit with a header
SK	Single knife
SKD	Single-knife drive
Soft joint	A joint made with use of a fastener where joining materials are compressible or experience relaxation over a period of time
spm	Strokes per minute
Tension	Axial load placed on a bolt or screw, usually measured in Newtons (N) or pounds (lb.)
TFFT	Turns from finger tight
Torque	The product of a force X lever arm length, usually measured in Newton-meters (N·m) or foot-pounds (ft·lbf)

REFERENCE

Term	Definition
Torque angle	A tightening procedure where fitting is assembled to a precondition (finger tight) and then nut is turned further a number of degrees or a number of flats to achieve its final position
Torque-tension	The relationship between assembly torque applied to a piece of hardware and axial load it induces in bolt or screw
ULSD	Ultra low sulphur diesel
UCA	Upper cross auger
Washer	A thin cylinder with a hole or slot located in the center that is to be used as a spacer, load distribution element, or a locking mechanism
Windrower	Power unit of a self-propelled header
WCM	Windrower control module

Predelivery Checklist

Perform these checks and adjustments prior to delivery to your Customer. The completed checklist should be retained by either the Operator or the Dealer.

CAUTION

Carefully follow the instructions given. Be alert for safety related messages that bring your attention to hazards and unsafe practices.

Windrower Serial Number:

Engine Serial Number:

Table 1 M155E4 Self-Propelled Windrower Predelivery Checklist

✓	Item	Reference
	Check for shipping damage or missing parts. Be sure all shipping dunnage is removed.	—
	Check for loose hardware. Tighten to required torque.	6 Reference, page 159
	Check tire air pressures and adjust as required.	5.3.1 Checking Tire Pressures, page 133
	Check wheel drive hub lubricant level.	5.2 Checking Wheel Drive Lubricant Level, page 132
	Check engine coolant level and strength at pressurized coolant tank.	5.7 Checking Engine Coolant, page 139
	Check that Diesel Exhaust Fluid (DEF) has been drained and tank refilled with fresh DEF.	5.8 Draining and Refilling the Diesel Exhaust Fluid (DEF) Tank, page 140
	Check air cleaner and clamps.	5.4 Checking Engine Air Intake, page 135
	Check hydraulic oil level and check for leaks along lines.	5.5 Checking Hydraulic Oil, page 137
	Check fuel separator for water and foreign material, drain and clean as necessary, and add fuel.	5.6 Checking Fuel Separator, page 138
	Check gear box lubricant level.	5.9 Checking Gearbox Lubricant Level, page 142
	Check tension of A/C compressor belt.	5.10 Checking Air Conditioning (A/C) Compressor Belts, page 143
	Check that machine is completely lubricated.	3.10 Lubricating the Windrower, page 62
	Check neutral interlock system.	5.11 Checking Safety System, page 144
	Check horn operation.	5.12.8 Checking Horn, page 154
	Check engine oil pressure indicator light at cab display module (CDM).	5.12.1 Checking Engine Warning Lights, page 146
	Start engine and run to operating temperature.	5.12.2 Checking Windrower Startup, page 147
	Check CDM and fuel and diesel exhaust fluid (DEF) gauges for operation.	5.12.4 Checking Gauges and Cab Display Module (CDM) Display, page 148
	Check Operator's Presence System.	5.12.6 Checking Operator's Presence System, page 149
	Check alternator charge rate at instrument console.	5.12.5 Checking Electrical System, page 148

PREDELIVERY CHECKLIST

✓	Item	Reference
	Check that air conditioning is functioning properly.	5.12.10 Checking Air Conditioning (A/C) and Heater, page 155
	Check that heater is functioning properly.	5.12.10 Checking Air Conditioning (A/C) and Heater, page 155
	Check that interior lights are functioning properly.	5.12.9 Checking Interior Lights, page 154
	Check maximum (no load) engine speed at CDM.	5.12.3 Checking Engine Speed, page 147
	Check that exterior lights are functioning properly.	5.12.7 Checking Exterior Lights, page 151
	Check that hazard and signal lights are functioning properly.	5.12.7 Checking Exterior Lights, page 151
	Check that beacons are functioning properly (if installed).	5.12.7 Checking Exterior Lights, page 151
	Complete the header's Predelivery Checklist (if applicable).	—
	Check that manuals are in the windrower manual case.	5.13 Checking Manuals, page 156
	Check that plastic coverings from cab interior have been removed.	5.14 Performing Final Steps, page 157

Date Checked:

Checked by:

MacDon Industries Ltd.

680 Moray Street
Winnipeg, Manitoba
Canada R3J 3S3
t. (204) 885-5590
f. (204) 832-7749

MacDon, Inc.

10708 N. Pomona Avenue
Kansas City, Missouri
United States 64153-1924
t. (816) 891-7313
f. (816) 891-7323

MacDon Australia Pty. Ltd.

A.C.N. 079 393 721
P.O. Box 243, Suite 3, 143 Main Street
Greensborough, Victoria, Australia 3088
t. 03 9432 9982
f. 03 9432 9972

LLC MacDon Russia Ltd.

123317 Moscow, Russia
10 Presnenskaya nab, Block C
Floor 5, Office No. 534, Regus Business Centre
t. +7 495 775 6971
f. +7 495 967 7600

CUSTOMERS

MacDon.com

DEALERS

Portal.MacDon.com

Trademarks of products are the marks of their respective manufacturers and/or distributors.

Printed in Canada