

# FD1 Series FlexDraper® Combine Header with FM100 Float Module

Unloading and Assembly Instructions (North America)

215337 Revision A

Original Instruction

*Featuring MacDon FLEX-FLOAT Technology™*

*The Harvesting Specialists.*

FD1 Series FlexDraper® Header for Combines and FM100 Float Module

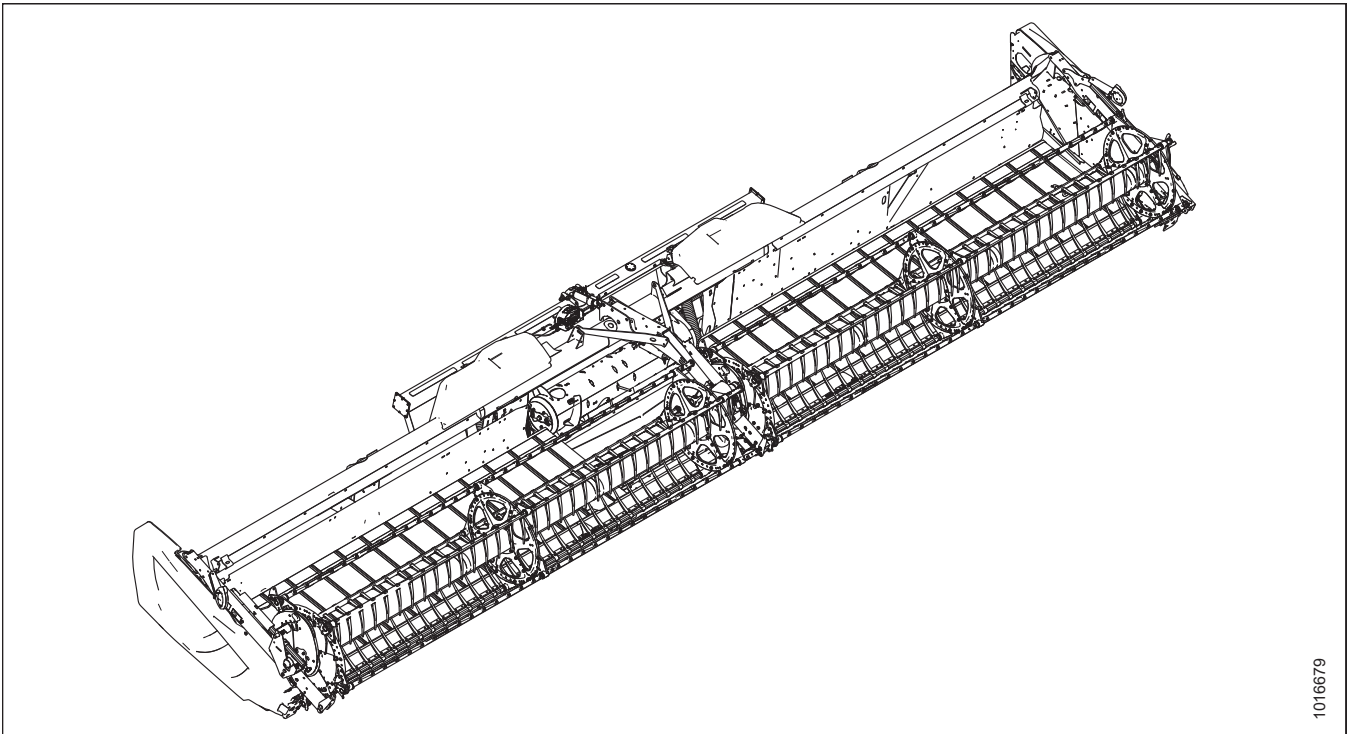

1016679

Published: July 2020

© 2020 MacDon Industries, Ltd.

The information in this publication is based on the information available and in effect at the time of printing. MacDon Industries, Ltd. makes no representation or warranty of any kind, whether expressed or implied, with respect to the information in this publication. MacDon Industries, Ltd. reserves the right to make changes at any time without notice.

## Introduction

This instruction manual describes the unloading, setup, and predelivery requirements for the MacDon FD1 Series FlexDraper® Combine Header with FM100 Float Module.

To ensure the best performance of this product and the safety of your customers, carefully follow the unload and assembly procedure from the beginning through to completion.

**Carefully read all the material provided before attempting to unload, assemble, or use the machine.**

Retain this instruction for future reference.

### **Conventions**

The following conventions are used in this document:

- Right and left are determined from the operator's position. The front of the header faces the crop.
- Unless otherwise noted, use the standard torque values provided in this manual.

### **NOTE:**

Keep your MacDon publications up-to-date. The latest version can be downloaded from our website ([www.macdon.com](http://www.macdon.com)) or from our Dealer portal (<https://portal.macdon.com>) (login required).

This document is currently available in French and English.

## Summary of Changes

Section	Summary of Change	Internal Use Only
<a href="#">2.3 Removing Shipping Stands, page 10</a>	Clarified shipping leg stands are used on 30–45 ft. headers only. Added center shipping support for single reel FD125 headers.	ECN 59457
	Updated illustration of shipping leg stand.	ECN 57608
<a href="#">3.1 Attaching Reel Lift Cylinders, page 19</a>	Updated illustrations of center arm shipping support.	ECN 58690
	Clarified center arm shipping support is for double reel headers only.	ECN 59457
<a href="#">4.1 Installing Filler Cap, page 35</a>	Removed step for applying Loctite® 565 to screws.	ECN 59259
<a href="#">4.2 FM100 Feed Auger Configurations, page 38</a>	AGCO IDEAL™ feed auger changed to narrow flighting configuration.	ECN 59301
	Added combine models to medium configuration list: <ul style="list-style-type: none"> <li>• Case IH 2300/2500 Series</li> <li>• Case IH 5/6/7150, 7/8/9250</li> <li>• CLAAS 7000/8000, Tucano</li> <li>• John Deere S76/77/78/790,</li> <li>• New Holland 10.80/10.90</li> <li>• Rostselmash Torum 760/780</li> </ul> Added AGCO IDEAL™ to medium configuration as an optional configuration. Added CLAAS 8000 to wide configuration as an optional configuration. Added note to Ultra Narrow configuration: “You will need to drill holes in the flighting and in the drum to install the extra flighting.” Added Ultra Wide configuration.	Engineering, Support
	Revised auger configuration conversion procedures because feed augers are now factory-equipped with magnetic reverser shields.	ECN 59123
<a href="#">4.2.7 Converting from Ultra Narrow or Narrow Configuration to Ultra Wide Configuration, page 61</a>	Added topic.	Support, Engineering
<ul style="list-style-type: none"> <li>• <a href="#">4.2.11 Installing Feed Auger Fingers, page 75</a></li> <li>• <a href="#">4.2.12 Removing Feed Auger Fingers, page 77</a></li> </ul>	Revised installing/removing auger finger procedures because feed augers are now factory-equipped with solid fingers.	ECN 59724

<b>Section</b>	<b>Summary of Change</b>	<b>Internal Use Only</b>
<i>6.10 Centering Reel on Single-Reel Header, page 146</i>	Added topic for single reel.	ECN 59457
<i>6.11 Checking and Adjusting Header Float, page 148</i>	Added FD125 to the float settings table.	ECN 59457
<i>6.13 Reel Clearance to Cutterbar, page 161</i>	Added FD125 to reel clearance table.	ECN 59457
<i>6.13.1 Measuring Reel Clearance, page 161</i>	Added single reel measuring points.	ECN 59457
<i>6.13.2 Adjusting Reel Clearance, page 163</i>	Clarified center arm adjustment applies to double reel only.	ECN 59457
<i>6.16 Checking and Adjusting Draper Seal, page 170</i>	Added instructions for adjusting deck height, if required.  Added note explaining why factory-installed drapers have different gap requirement than replacement drapers.	Support
<i>7.1.11 CLAAS 7000/8000 Series Combines, page 260</i>	Added CLAAS 7000/8000 Series to AHHC section.	Support
<i>8.1 Checking and Adjusting Reel Height Sensor, page 365</i>	Corrected note about direction of pointer for the two sensor configurations.	Support
<i>9.1 Adjusting Knife Speed, page 371</i>	Added FD125 knife speed information. Moved Adjusting Knife Speed from Post Run-up to Run-up.	ECN 59457, Support
	Revised knife speed range table.	Support, Engineering
<i>Predelivery Checklist, page 393</i>	Added Checking and Adjusting Feed Draper Tension to post run-up on PDI checklist.	Tech Pubs



## TABLE OF CONTENTS

Introduction .....	i
<b>Chapter 1: Safety .....</b>	<b>1</b>
1.1 Signal Words .....	1
1.2 General Safety .....	2
1.3 Safety Signs .....	4
<b>Chapter 2: Unloading the Header .....</b>	<b>5</b>
2.1 Unloading Header and Float Module from Trailer.....	5
2.2 Lowering Header .....	7
2.3 Removing Shipping Stands .....	10
2.4 Removing Endshields from Shipping Position – FD145 Headers.....	15
<b>Chapter 3: Assembling Header and Float Module .....</b>	<b>19</b>
3.1 Attaching Reel Lift Cylinders .....	19
3.2 Attaching Reel Height Sensor.....	26
3.3 Attaching Cam Arms .....	29
3.4 Repositioning Gearbox .....	31
3.5 Installing Driveline .....	33
<b>Chapter 4: Setting up Float Module at Dealer .....</b>	<b>35</b>
4.1 Installing Filler Cap.....	35
4.2 FM100 Feed Auger Configurations.....	38
4.2.1 Converting from Ultra Narrow Configuration or Narrow Configuration to Medium Configuration .....	41
4.2.2 Converting from Wide Configuration to Medium Configuration.....	45
4.2.3 Converting from Medium Configuration or Wide Configuration to Narrow Configuration.....	47
4.2.4 Converting from Ultra Narrow Configuration to Narrow Configuration .....	51
4.2.5 Converting from Medium Configuration to Wide Configuration or Ultra Wide Configuration .....	52
4.2.6 Converting from Ultra Narrow or Narrow Configuration to Wide Configuration.....	57
4.2.7 Converting from Ultra Narrow or Narrow Configuration to Ultra Wide Configuration .....	61
4.2.8 Converting from Wide Configuration to Ultra Wide Configuration .....	64
4.2.9 Converting from Medium Configuration or Wide Configuration to Ultra Narrow Configuration .....	66
4.2.10 Converting from Narrow Configuration to Ultra Narrow Configuration.....	73
4.2.11 Installing Feed Auger Fingers.....	75
4.2.12 Removing Feed Auger Fingers.....	77
4.3 FM100 Stripper Bars and Feed Deflectors .....	80
4.3.1 Removing Stripper Bars.....	80
4.3.2 CR Feeder Deflectors .....	80
4.3.3 Replacing Feed Deflectors on New Holland CR Combines .....	81
<b>Chapter 5: Attaching Header to Combine .....</b>	<b>83</b>
5.1 AGCO (Challenger, Gleaner, and Massey Ferguson) Combines.....	83
5.1.1 Installing Reel Fore-Aft / Header Tilt Selector Switch and Harness .....	83

## TABLE OF CONTENTS

5.1.2 Attaching Header to an AGCO (Challenger, Gleaner, or Massey Ferguson) Combine .....	87
<b>5.2 AGCO IDEAL™ Series Combines .....</b>	<b>91</b>
5.2.1 Attaching Header to an AGCO IDEAL™ Series Combine .....	91
<b>5.3 Case IH Combines .....</b>	<b>94</b>
5.3.1 Attaching Header to Case IH Combine .....	94
5.3.2 Enabling Reel Fore-Aft / Header Tilt – Case IH 250 Series .....	99
<b>5.4 John Deere Combines.....</b>	<b>101</b>
5.4.1 Attaching Header to John Deere Combine .....	101
5.4.2 Installing Reel Fore-Aft / Header Tilt Switch – S and T Series Combines.....	104
5.4.3 Installing Reel Fore-Aft / Header Tilt Switch – 60 and 70 Series Combines .....	111
<b>5.5 CLAAS Combines .....</b>	<b>116</b>
5.5.1 Attaching Header to CLAAS Combine .....	116
<b>5.6 New Holland Combines .....</b>	<b>121</b>
5.6.1 Attaching Header to New Holland CR/CX Combine.....	121
<b>5.7 Completing Header Assembly .....</b>	<b>126</b>
5.7.1 Removing Shipping Supports.....	126
5.7.2 Positioning Transport Lights.....	127
5.7.3 Crop Dividers .....	127
Removing Crop Dividers from Storage .....	127
Opening Endshields.....	128
Installing Crop Divider without Latch Option.....	128
Installing Crop Divider with Latch Option .....	130
Closing Endshields .....	131
Installing Crop Divider Rods.....	131
5.7.4 Installing Options .....	132
<b>Chapter 6: Performing Predelivery Checks.....</b>	<b>133</b>
6.1 Recording Model and Serial Number.....	133
6.2 Checking Tire Pressure – Transport and Stabilizer Wheels.....	135
6.3 Checking Wheel Bolt Torque – Transport and Stabilizer Wheels.....	136
6.4 Checking Knife Drive Box .....	137
6.5 Checking Oil Level in Header Drive Gearbox .....	139
6.6 Checking Oil Level in Hydraulic Reservoir .....	140
6.7 Checking Knife Drive Belt Tension.....	141
6.8 Checking Pointed Guard Hold-Downs .....	142
6.8.1 Adjusting Pointed Guard Hold-Downs .....	143
6.8.2 Adjusting Hold-Down Clips at Double-Knife Center Pointed Guard .....	143
6.9 Centering Reel on Double-Reel Header.....	144
6.10 Centering Reel on Single-Reel Header.....	146
6.11 Checking and Adjusting Header Float .....	148
6.12 Checking and Adjusting Header Wing Balance.....	153
6.12.1 Checking Wing Balance .....	153
6.12.2 Adjusting Wing Balance .....	158



## TABLE OF CONTENTS

<b>6.13</b>	Reel Clearance to Cutterbar .....	161
6.13.1	Measuring Reel Clearance .....	161
6.13.2	Adjusting Reel Clearance .....	163
<b>6.14</b>	Adjusting Auger to Pan Clearance .....	165
<b>6.15</b>	Adjusting Draper Tension .....	168
<b>6.16</b>	Checking and Adjusting Draper Seal .....	170
<b>6.17</b>	Lubricating Header .....	173
6.17.1	Greasing Procedure .....	173
6.17.2	Lubrication Points .....	174
<b>6.18</b>	Checking and Adjusting Endshields.....	180
<b>6.19</b>	Checking Manuals .....	184
<b>Chapter 7: Setting up Auto Header Height Control .....</b>		<b>185</b>
<b>7.1</b>	Auto Header Height Control .....	185
7.1.1	Sensor Operation .....	186
7.1.2	Troubleshooting Auto Header Height / Float Indicator .....	186
7.1.3	Sensor Output Voltage Range – Combine Requirements .....	187
	10 Volt Adapter (MD #B6421) – New Holland Combines Only .....	188
	Manually Checking Voltage Range – One-Sensor System.....	188
	Manually Checking Voltage Range – Two-Sensor System .....	191
	Adjusting Voltage Limits – One-Sensor System .....	194
	Adjusting Voltage Limits – Two-Sensor System.....	195
7.1.4	AGCO IDEAL™ Series Combines .....	197
	Setting up the Header – AGCO IDEAL™ Series .....	197
	Setting Minimum Reel Speed and Calibrating Reel – AGCO IDEAL™ Series.....	201
	Setting up Automatic Header Controls – AGCO IDEAL™ Series .....	203
	Calibrating the Header – AGCO IDEAL™ Series .....	204
	Operating the Header – AGCO IDEAL™ Series .....	206
	Reviewing Header In-Field Settings – AGCO IDEAL™ Series .....	208
7.1.5	Case IH 5088/6088/7088 Combines.....	209
	Calibrating the Auto Header Height Control – Case IH 5088/6088/7088 .....	209
	Setting the Sensitivity of the Auto Header Height – Case IH 5088/6088/7088 .....	210
7.1.6	Case IH 130 and 140 Series Mid-Range Combines .....	212
	Setting up the Header on the Combine Display – Case IH 5130/6130/7130; 5140/6140/7140.....	212
	Checking Voltage Range from Combine Cab – Case IH 5130/6130/7130; 5140/6140/7140.....	214
	Calibrating Auto Header Height Control – Case IH 5130/6130/7130, 5140/6140/7140 .....	216
	Setting Preset Cutting Height – Case 5130/6130/7130, 5140/6140/7140 .....	217
7.1.7	Case IH 7010/8010, 120, 230, 240, and 250 Series Combines.....	220
	Checking Voltage Range from the Combine Cab – Case IH 8010 .....	220
	Setting Header Controls – Case IH 8010 .....	222
	Checking Voltage Range from the Combine Cab – Case IH 7010/8010, 120, 230, 240, and 250 Series Combines.....	223
	Calibrating the Auto Header Height Control – Case IH 7010/8010,120, 230, 240, and 250 Series Combines.....	225
	Calibrating the Auto Header Height Control – Case IH Combines with Version 28.00 or Higher Software.....	229
	Checking Reel Height Sensor Voltages – Case IH Combines .....	232
	Setting Preset Cutting Height – Case IH 7010/8010, 120, 230, 240, and 250 Series Combines .....	234
7.1.8	Challenger and Massey Ferguson 6 and 7 Series Combines.....	235

## TABLE OF CONTENTS

Checking Voltage Range from the Combine Cab – Challenger and Massey Ferguson .....	235
Engaging the Auto Header Height Control – Challenger and Massey Ferguson .....	237
Calibrating the Auto Header Height Control – Challenger and Massey Ferguson .....	237
Adjusting the Header Height – Challenger and Massey Ferguson.....	240
Adjusting the Header Raise/Lower Rate – Challenger and Massey Ferguson.....	240
Setting the Sensitivity of the Auto Header Height Control – Challenger and Massey Ferguson .....	241
7.1.9 CLAAS 500 Series Combines .....	242
Calibrating the Auto Header Height Control – CLAAS 500 Series.....	242
Setting Cutting Height – CLAAS 500 Series.....	244
Setting the Sensitivity of the Auto Header Height Control – CLAAS 500 Series .....	246
Adjusting Auto Reel Speed – CLAAS 500 Series.....	249
7.1.10 CLAAS 600 and 700 Series Combines .....	251
Calibrating the Auto Header Height Control – CLAAS 600 and 700 Series.....	251
Setting Cutting Height – CLAAS 600 and 700 Series.....	254
Setting the Sensitivity of the Auto Header Height Control – CLAAS 600 and 700 Series.....	254
Adjusting Auto Reel Speed – CLAAS 600 and 700 Series.....	255
Calibrating Reel Height Sensor – CLAAS 600 and 700 Series.....	257
Adjusting Auto Reel Height – CLAAS 600 and 700 Series .....	259
7.1.11 CLAAS 7000/8000 Series Combines.....	260
Setting up the Header – CLAAS 7000/8000 Series .....	260
Setting up the Header Fore-Aft Tilt Function – CLAAS 7000/8000 Series .....	262
Calibrating the Auto Header Height Control – CLAAS 7000/8000 Series .....	264
Setting Cut and Reel Height Preset – CLAAS 7000/8000 Series .....	266
Setting the Sensitivity of the Auto Header Height Control – CLAAS 7000/8000 Series.....	267
Adjusting Auto Reel Speed – CLAAS 7000/8000 Series.....	268
Calibrating Reel Height Sensor – CLAAS 7000/8000 Series.....	270
7.1.12 Gleaner R65/R66/R75/R76 and S Series Combines .....	271
Checking Voltage Range from the Combine Cab – Gleaner R65/R66/R75/R76 and Pre-2016 S Series.....	271
Engaging the Auto Header Height Control – Gleaner R65/R66/R75/R76 and Pre-2016 S Series .....	273
Calibrating the Auto Header Height Control – Gleaner R65/R66/R75/R76 and Pre-2016 S Series.....	275
Turning off the Accumulator – Gleaner R65/R66/R75/R76 and Pre-2016 S Series .....	276
Adjusting the Header Raise/Lower Rate – Gleaner R65/R66/R75/R76 and Pre-2016 S Series .....	277
Adjusting Ground Pressure – Gleaner R65/R66/R75/R76 and Pre-2016 S Series .....	277
Adjusting the Sensitivity of the Auto Header Height Control – Gleaner R65/R66/R75/R76 and Pre-2016 S Series.....	278
Troubleshooting Alarms and Diagnostic Faults – Gleaner R65/R66/R75/R76 and Pre-2016 S Series.....	279
7.1.13 Gleaner S9 Series Combines .....	281
Setting up the Header – Gleaner S9 Series .....	281
Setting Minimum Reel Speed and Calibrating Reel – Gleaner S9 Series.....	286
Setting up Automatic Header Controls – Gleaner S9 Series.....	288
Calibrating the Header – Gleaner S9 Series.....	290
Operating the Auto Header Height Control – Gleaner S9 Series.....	293
Reviewing Header In-Field Settings – Gleaner S9 Series .....	294
7.1.14 John Deere 60 Series Combines .....	295
Checking Voltage Range from the Combine Cab – John Deere 60 Series .....	295
Calibrating the Auto Header Height Control – John Deere 60 Series.....	297
Turning the Accumulator Off – John Deere 60 Series.....	299
Setting the Sensing Grain Header Height to 50 – John Deere 60 Series.....	299
Setting the Sensitivity of the Auto Header Height Control – John Deere 60 Series .....	300
Adjusting the Threshold for the Drop Rate Valve – John Deere 60 Series .....	301
7.1.15 John Deere 70 Series Combines .....	302

## TABLE OF CONTENTS

Checking Voltage Range from the Combine Cab – John Deere 70 Series .....	302
Calibrating Feeder House Speed – John Deere 70 Series .....	305
Calibrating the Auto Header Height Control – John Deere 70 Series .....	305
Setting the Sensitivity of the Auto Header Height Control – John Deere 70 Series .....	308
Adjusting the Manual Header Raise/Lower Rate – John Deere 70 Series .....	308
<b>7.1.16 John Deere S and T Series Combines .....</b>	<b>309</b>
Checking Voltage Range from the Combine Cab – John Deere S and T Series .....	309
Calibrating the Auto Header Height Control – John Deere S and T Series .....	313
Setting the Sensitivity of the Auto Header Height Control – John Deere S and T Series .....	316
Adjusting the Manual Header Raise/Lower Rate – John Deere S and T Series .....	317
Setting Preset Cutting Height – John Deere S and T Series .....	318
Calibrating Feeder House Fore-Aft Tilt Range – John Deere S and T Series .....	320
Checking Reel Height Sensor Voltages – John Deere S and T Series .....	323
Calibrating Reel Height Sensor – John Deere S and T Series .....	325
<b>7.1.17 John Deere S7 Series Combines .....</b>	<b>327</b>
Setting up Header – John Deere S7 Series .....	327
Checking Voltage Range from the Combine Cab – John Deere S7 Series .....	331
Calibrating Feeder House – John Deere S7 Series .....	333
Calibrating Header – John Deere S7 Series .....	336
<b>7.1.18 New Holland Combines – CR/CX Series – 2014 and Prior .....</b>	<b>339</b>
Checking Voltage Range from the Combine Cab – New Holland CR/CX Series .....	339
Setting up Auto Header Height Control – New Holland CR/CX Series .....	341
Calibrating the Auto Header Height Control – New Holland CR/CX Series .....	342
Calibrating Maximum Stubble Height – New Holland CR/CX Series .....	345
Adjusting Header Raise Rate – New Holland CR/CX Series .....	346
Setting the Header Lower Rate – New Holland CR/CX Series .....	347
Setting the Sensitivity of the Auto Header Height Control – New Holland CR/CX Series .....	347
Setting Preset Cutting Height – New Holland CR/CX Series .....	348
<b>7.1.19 New Holland Combines – CR Series – 2015 and Later .....</b>	<b>349</b>
Checking Voltage Range from the Combine Cab – New Holland CR Series .....	349
Setting up Auto Header Height Control – New Holland CR Series .....	352
Calibrating the Auto Header Height Control – New Holland CR Series .....	355
Checking Reel Height Sensor Voltages – New Holland CR Series .....	358
Setting Preset Cutting Height – New Holland CR Series .....	359
Setting Maximum Work Height – New Holland CR Series .....	361
Configuring Reel Fore-Aft, Header Tilt, and Header Type – New Holland CR Series .....	362
<b>Chapter 8: Setting up Reel Height Sensor .....</b>	<b>365</b>
<b>8.1 Checking and Adjusting Reel Height Sensor .....</b>	<b>365</b>
<b>Chapter 9: Running up Header .....</b>	<b>369</b>
<b>9.1 Adjusting Knife Speed .....</b>	<b>371</b>
<b>9.2 Performing Post Run-Up Adjustments .....</b>	<b>374</b>
9.2.1 Adjusting Knife .....	375
9.2.2 Checking and Adjusting Feed Draper Tension .....	376
<b>Chapter 10: Reference .....</b>	<b>377</b>
<b>10.1 Reel Safety Props .....</b>	<b>377</b>
10.1.1 Engaging Reel Safety Props .....	377
10.1.2 Disengaging Reel Safety Props .....	378

**TABLE OF CONTENTS**

---

**10.2** Torque Specifications ..... 380

    10.2.1 Metric Bolt Specifications ..... 380

    10.2.2 Metric Bolt Specifications Bolting into Cast Aluminum ..... 382

    10.2.3 Flare-Type Hydraulic Fittings ..... 382

    10.2.4 O-Ring Boss Hydraulic Fittings – Adjustable..... 383

    10.2.5 O-Ring Boss Hydraulic Fittings – Non-Adjustable ..... 385

    10.2.6 O-Ring Face Seal Hydraulic Fittings ..... 386

    10.2.7 Tapered Pipe Thread Fittings ..... 387

**10.3** Lifting Equipment Requirements..... 388

**10.4** Conversion Chart ..... 389

**10.5** Definitions ..... 390

**Predelivery Checklist ..... 393**

# Chapter 1: Safety

## 1.1 Signal Words

Three signal words, **DANGER**, **WARNING**, and **CAUTION**, are used to alert you to hazardous situations. Two signal words, **IMPORTANT** and **NOTE**, identify non-safety related information. Signal words are selected using the following guidelines:

### **DANGER**

Indicates an imminently hazardous situation that, if not avoided, will result in death or serious injury.

### **WARNING**

Indicates a potentially hazardous situation that, if not avoided, could result in death or serious injury. It may also be used to alert against unsafe practices.

### **CAUTION**

Indicates a potentially hazardous situation that, if not avoided, may result in minor or moderate injury. It may be used to alert against unsafe practices.

#### **IMPORTANT:**

Indicates a situation that, if not avoided, could result in a malfunction or damage to the machine.

#### **NOTE:**

Provides additional information or advice.

## 1.2 General Safety

### CAUTION

The following general farm safety precautions should be part of your operating procedure for all types of machinery.

Protect yourself when assembling, operating, and servicing machinery, wear all protective clothing and personal safety devices that could be necessary for the job at hand. Do **NOT** take chances. You may need the following:

- Hard hat
- Protective footwear with slip-resistant soles
- Protective glasses or goggles
- Heavy gloves
- Wet weather gear
- Respirator or filter mask

In addition, take the following precautions:

- Be aware that exposure to loud noises can cause hearing impairment or loss. Wear suitable hearing protection devices such as earmuffs or earplugs to help protect against loud noises.



Figure 1.1: Safety Equipment



Figure 1.2: Safety Equipment

- Provide a first aid kit in case of emergencies.
- Keep a properly maintained fire extinguisher on the machine. Be familiar with its proper use.
- Keep young children away from machinery at all times.
- Be aware that accidents often happen when the Operator is tired or in a hurry. Take time to consider the safest way. **NEVER** ignore warning signs of fatigue.

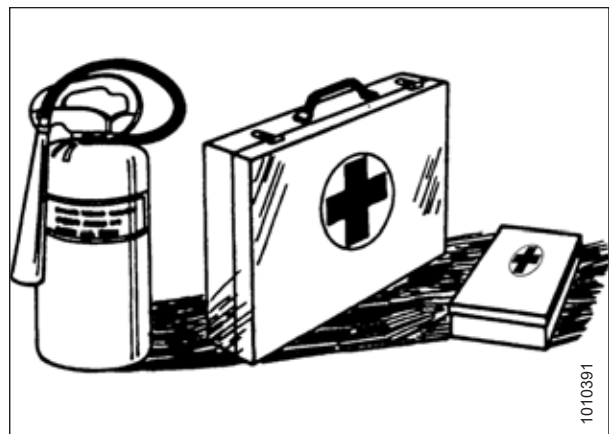

Figure 1.3: Safety Equipment

## SAFETY

- Wear close-fitting clothing and cover long hair. **NEVER** wear dangling items such as scarves or bracelets.
- Keep all shields in place. **NEVER** alter or remove safety equipment. Make sure driveline guards can rotate independently of shaft and can telescope freely.
- Use only service and repair parts made or approved by equipment manufacturer. Substituted parts may not meet strength, design, or safety requirements.



Figure 1.4: Safety around Equipment

- Keep hands, feet, clothing, and hair away from moving parts. **NEVER** attempt to clear obstructions or objects from a machine while the engine is running.
- Do **NOT** modify the machine. Unauthorized modifications may impair machine function and/or safety. It may also shorten the machine's life.
- To avoid injury or death from unexpected startup of the machine, **ALWAYS** stop the engine and remove the key from the ignition before leaving the operator's seat for any reason.

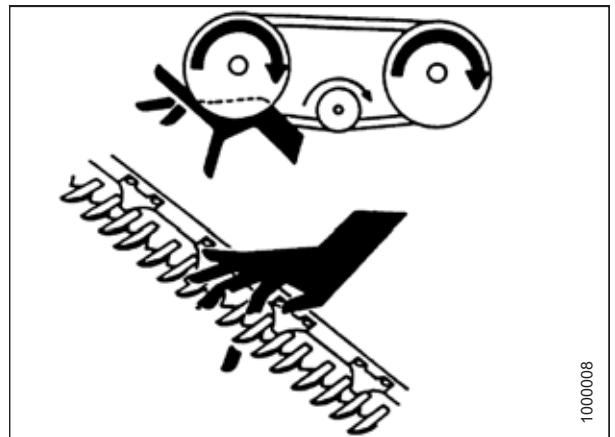

Figure 1.5: Safety around Equipment

- Keep service area clean and dry. Wet and/or oily floors are slippery. Wet spots can be dangerous when working with electrical equipment. Be sure all electrical outlets and tools are properly grounded.
- Keep work area well lit.
- Keep machinery clean. Straw and chaff on a hot engine are fire hazards. Do **NOT** allow oil or grease to accumulate on service platforms, ladders, or controls. Clean machines before storage.
- **NEVER** use gasoline, naphtha, or any volatile material for cleaning purposes. These materials may be toxic and/or flammable.
- When storing machinery, cover sharp or extending components to prevent injury from accidental contact.



Figure 1.6: Safety around Equipment

### 1.3 Safety Signs

- Keep safety signs clean and legible at all times.
- Replace safety signs that are missing or illegible.
- If the original part on which a safety sign was installed is replaced, be sure the repair part displays the current safety sign.

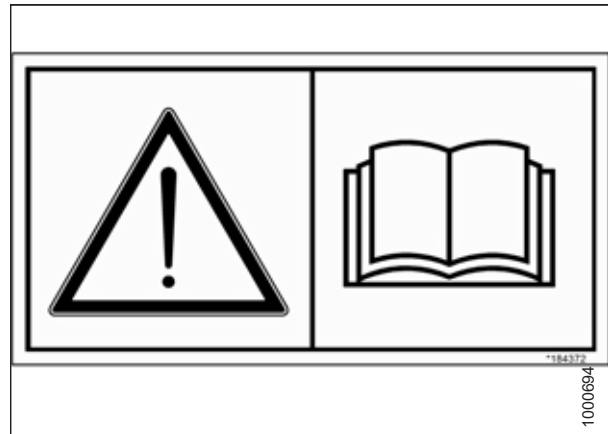

Figure 1.7: Operator's Manual Decal



## Chapter 2: Unloading the Header

Perform all procedures in this chapter in the order they are listed.

### 2.1 Unloading Header and Float Module from Trailer

The following procedure assumes that two headers were shipped on the trailer.

#### CAUTION

To avoid injury to bystanders from being struck by machinery, do not allow people to stand in unloading area.

#### CAUTION

Equipment used for unloading must meet or exceed the requirements specified below. Using inadequate equipment may result in chain breakage, vehicle tipping, or machine damage.

#### IMPORTANT:

Forklifts are normally rated with the load centered 610 mm (24 in.) from the back end of forks. To obtain forklift capacity for a load centered at 1220 mm (48 in.), check with your forklift distributor.

Table 2.1 Lifting Vehicle Requirements

Minimum Lifting Capacity	4082 kg (9000 lb.) load center (A) at 1220 mm (48 in.) (B) from back of forks
Minimum Fork Length (C)	1981 mm (78 in.)

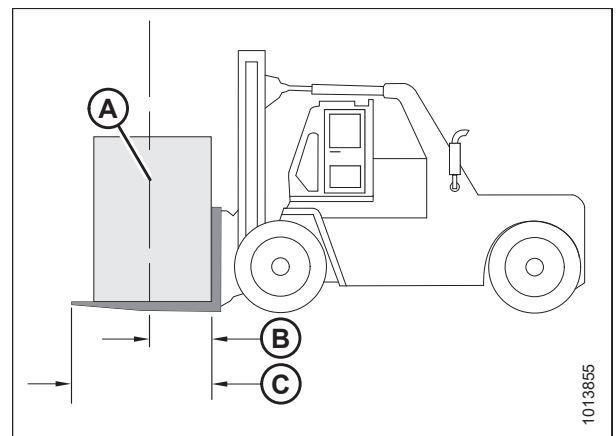

Figure 2.1: Minimum Lifting Capacity

A - Load Center of Gravity  
B - Load Center 1220 mm (48 in.) from Back of Forks  
C - Minimum Fork Length 1981 mm (78 in.)

To unload the headers and float modules from a trailer, follow these steps:

1. Move the trailer into position and block the trailer wheels.
2. Lower the trailer storage stands.

## UNLOADING THE HEADER

3. Approach one of the headers and line up forks (A) with fork slider channels (B) under the float module frame.
4. Slide forks (A) underneath fork slider channels (B) as far as possible without contacting the shipping support of the opposite header.
5. Remove the hauler's tie-down straps, chains, and wooden blocks.
6. Slowly raise the header off the trailer deck.

### **WARNING**

**Be sure forks are secure before moving away from load. Stand clear when lifting.**

7. Back up until the header clears the trailer and slowly lower it to 150 mm (6 in.) from the ground.

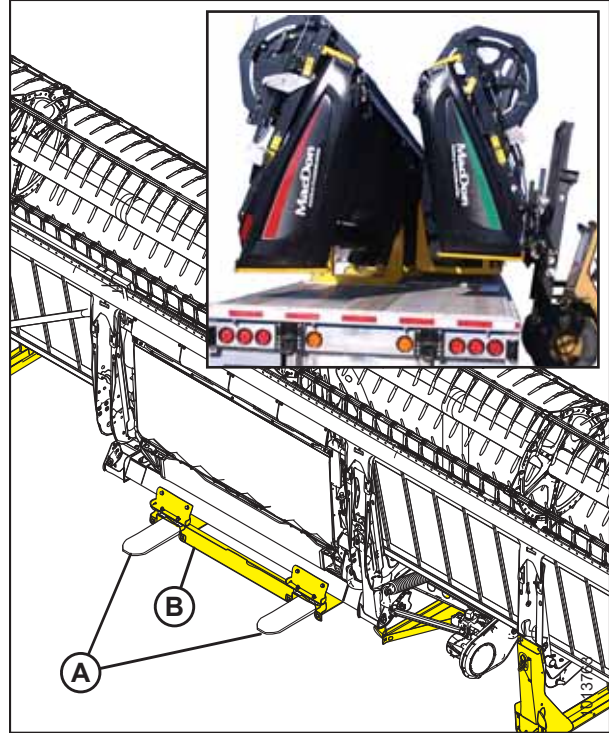

Figure 2.2: Header Shipping Supports

8. Take the header to the storage or setup area. Ensure the ground is flat and free of rocks or debris that could damage the header.
9. Repeat the previous steps for unloading the second header.
10. Check for shipping damage and missing parts.

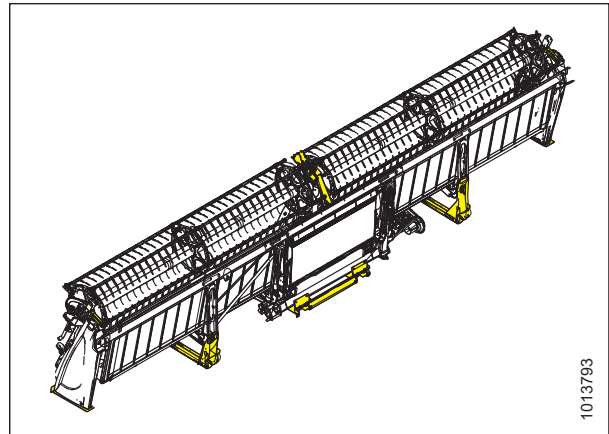

Figure 2.3: Header on Level Ground

## 2.2 Lowering Header

1. Approach the underside of the header with the lifting vehicle.

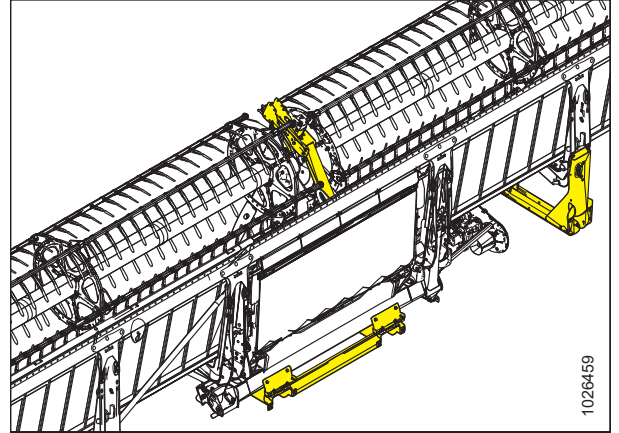

Figure 2.4: Underside of Header

2. Attach chain to shipping support (double reel [A]) (single reel [B]) at center reel arm.

**IMPORTANT:**

Do **NOT** attempt to lift at cutterbar when unloading from trailer. This procedure is **ONLY** for laying the machine over into working position.



**CAUTION**

Stand clear of header when lowering. Machine may swing.

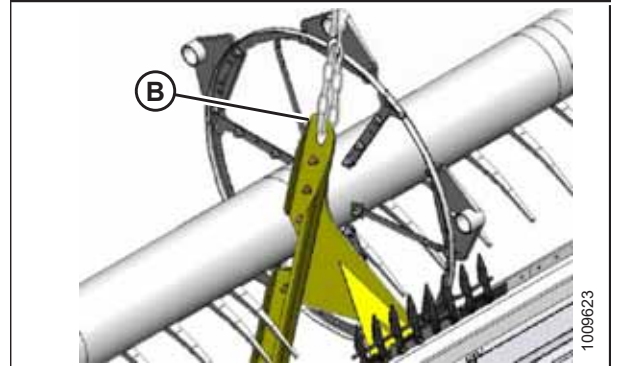
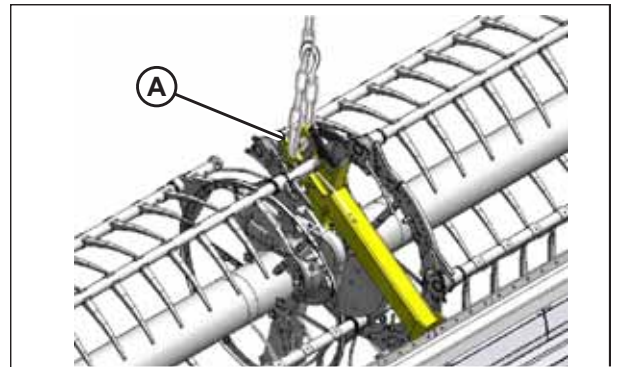

Figure 2.5: Chain Attachment Locations

A - Double Reel

B - Single Reel

## UNLOADING THE HEADER

3. Back up **SLOWLY** while lowering forks until header rests on the ground.



Figure 2.6: Header Lowered onto Ground

## UNLOADING THE HEADER

4. Place 150 mm (6 in.) blocks (A) under each end and at the center of cutterbar, then lower header onto blocks.
5. Remove chain.

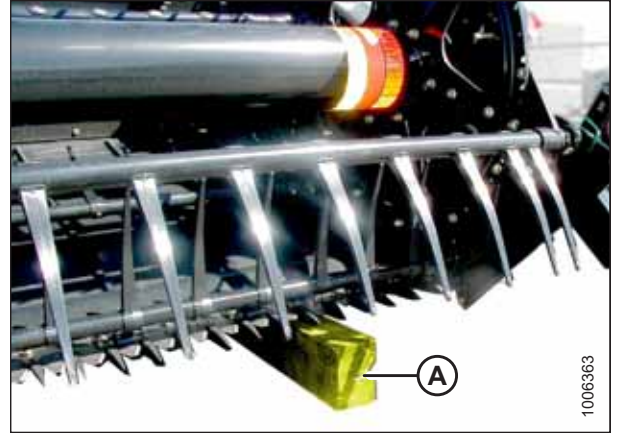

Figure 2.7: Blocks at Each End of Cutterbar

## 2.3 Removing Shipping Stands

**NOTE:**

Unless otherwise specified, discard stands, shipping material, and hardware. The removable stands are painted yellow or unpainted.

1. Remove two bolts (A) securing right fork channel (B) to shipping stand (C).

**NOTE:**

To access the bolts at the lower stand support, the header must be supported on 150 mm (6 in.) blocks, as directed in Step 4, [page 9](#).

2. Remove two bolts (D) securing right fork channel (B) to the lower brace.
3. Repeat the steps above for the left side.

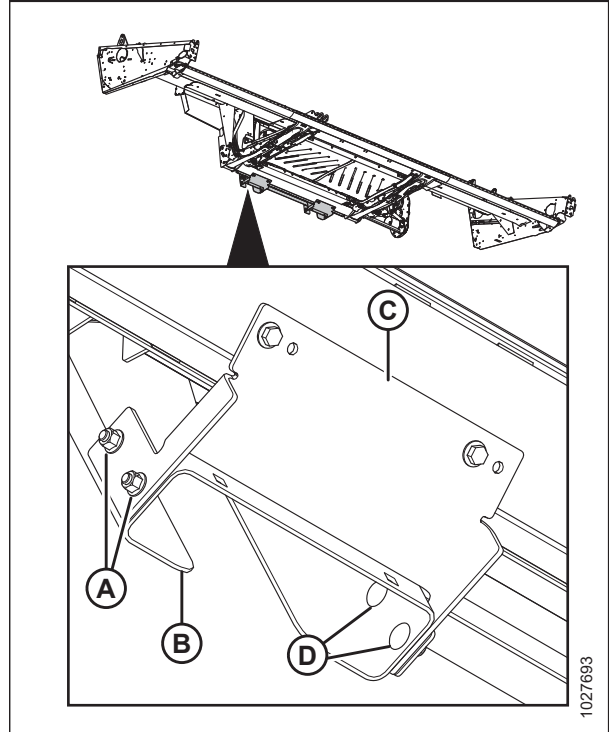

Figure 2.8: Shipping Supports

4. Remove lower brace (A).

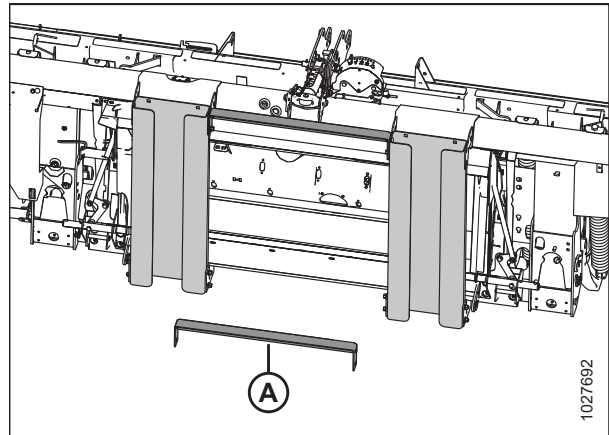

Figure 2.9: Shipping Supports

## UNLOADING THE HEADER

5. Remove two bolts (A) from the upper brace. Repeat for the opposite side.

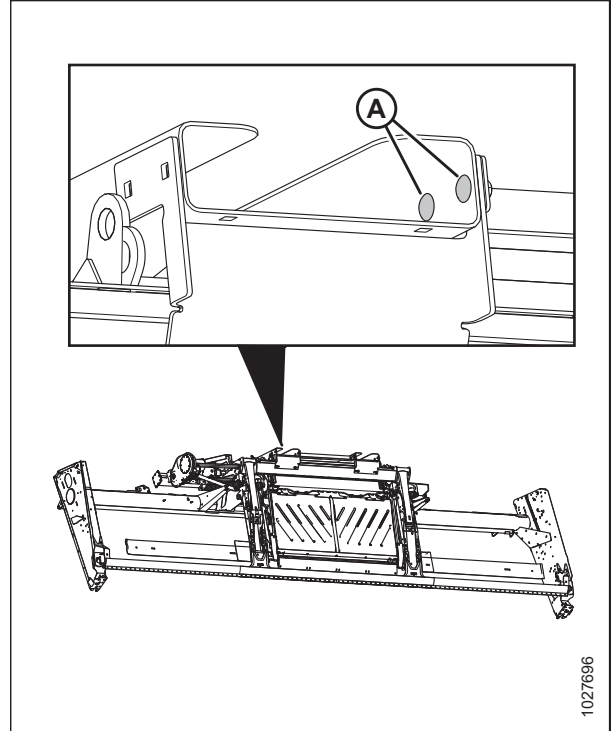

Figure 2.10: Shipping Supports

6. Remove right and left fork channels (A).
7. Remove upper brace (B).

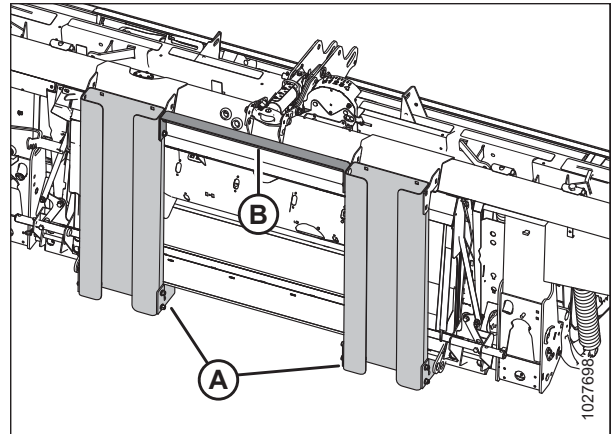

Figure 2.11: Shipping Supports

## UNLOADING THE HEADER

- Remove four bolts (A) and remove shipping stands (B) from the bottom of the float module.

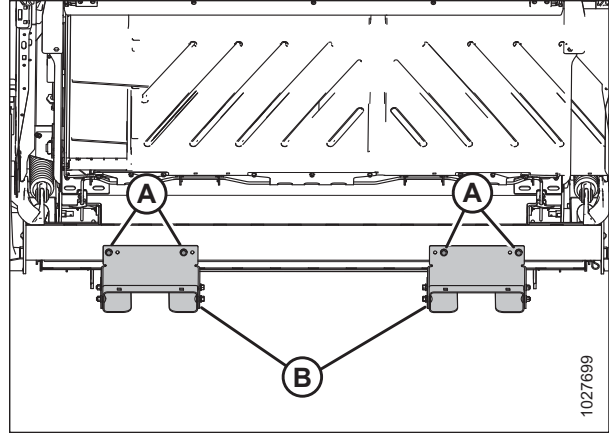

Figure 2.12: View from Below Header

- Remove two bolts (A) securing the bottom of coupler cover (B) to the float module.

### IMPORTANT:

Do **NOT** remove bolts (C) because they hold multicoupler components in place. Loosen bolts (C) only enough so that coupler cover (B) can be removed, and then make sure you retighten the bolts.

- Loosen two bolts (C), slide coupler cover to the left until cutouts are aligned with bolts, and then remove coupler cover (B).
- Tighten two bolts (C).

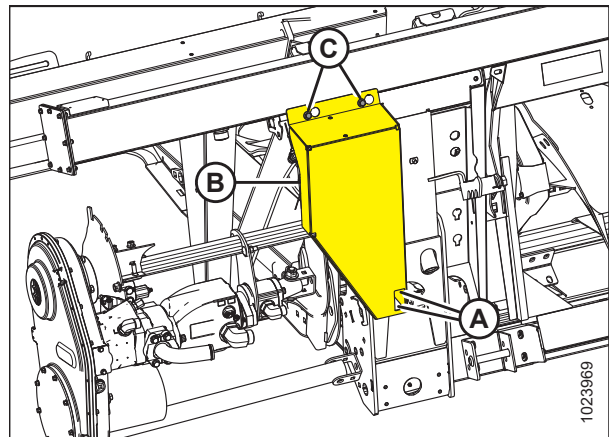

Figure 2.13: Coupler Cover

- FD130–FD145:** Remove four bolts (A) from the shipping stands at both outboard header legs. Remove stands (B).

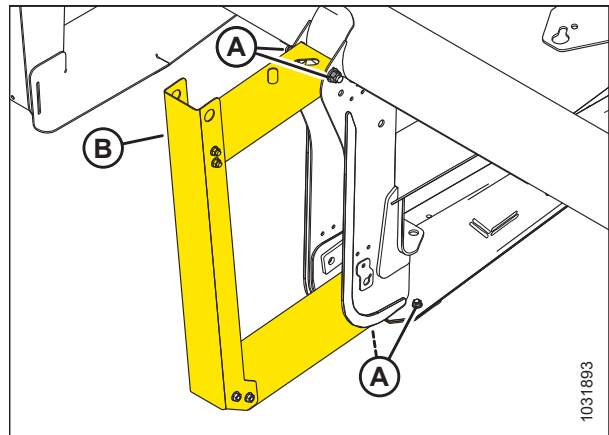

Figure 2.14: Shipping Stands at Outboard Legs – Right Side Shown



## UNLOADING THE HEADER

13. Remove reel anti-rotation strap (A) between reel and endsheet.

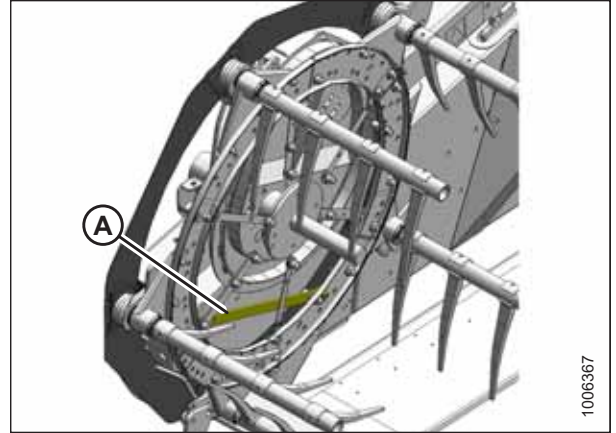

Figure 2.15: Reel Anti-Rotation Strap

14. Loosen two bolts (A) in each endshield guard (B), and remove guards.

**NOTE:**

Hardware can be removed when header endshields are opened.

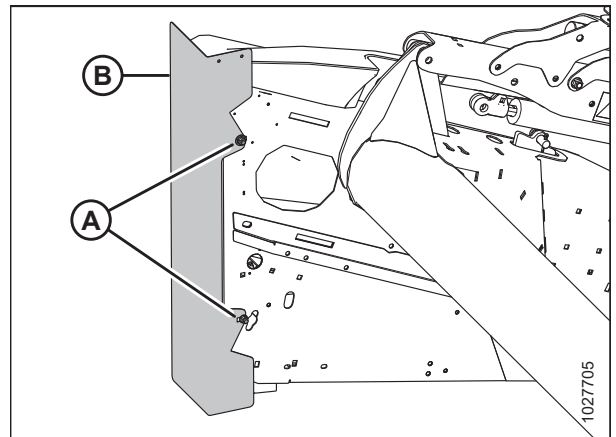

Figure 2.16: Endshield Guard

## UNLOADING THE HEADER

15. **Single Reel:** Remove the center shipping support by removing two bolts (A) at the backtube and three bolts (B) at the cutterbar.

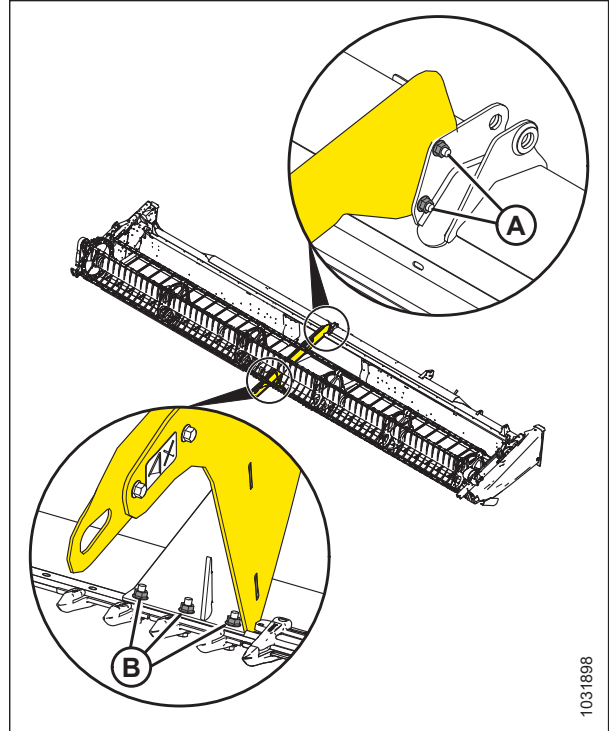

Figure 2.17: Single-Reel Center Shipping Support

## 2.4 Removing Endshields from Shipping Position – FD145 Headers

This procedure applies to FD145 headers only. All other header sizes are shipped with the endshields in operating position.

1. Loosen nuts (A) and remove screws (B). Use slots in shipping channel to access nuts. Remove channel (C).
2. Remove bolt (D) at front of endshield.

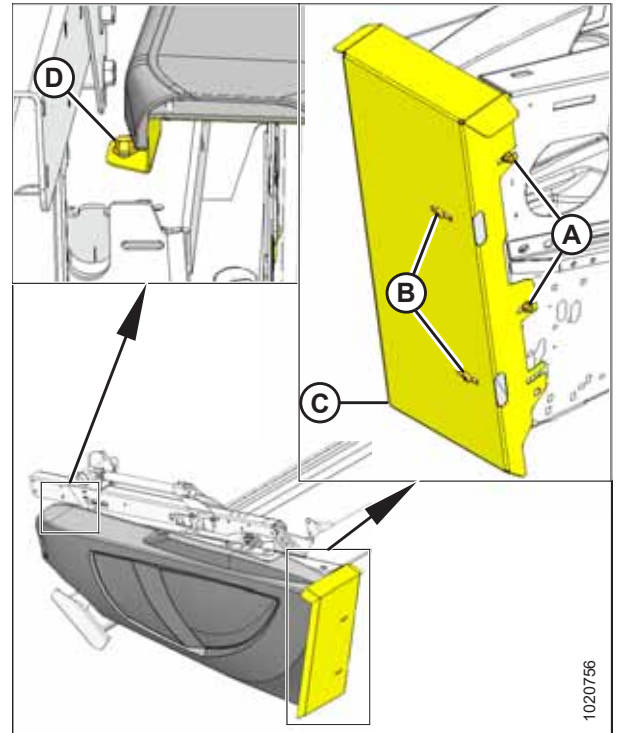

Figure 2.18: Left Endshield

3. Swivel endshield towards rear of header.

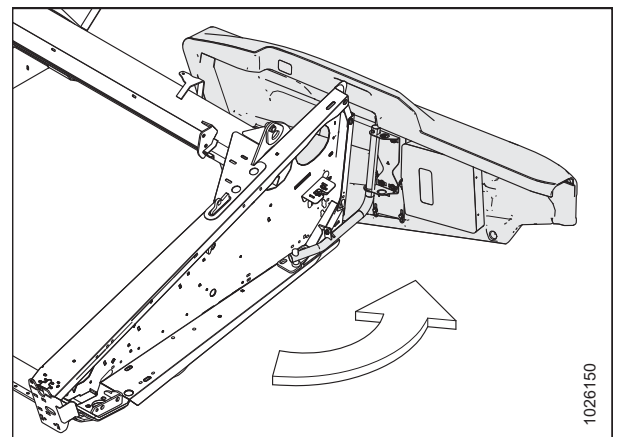

Figure 2.19: Left Endshield

## UNLOADING THE HEADER

4. Engage lock (A) to prevent endshield movement.
5. Remove self-tapping screw (B).
6. Slide endshield upwards and remove from hinge arm.

**NOTE:**

The inboard holes (position 2) on the endshield bracket are used for shipping position.

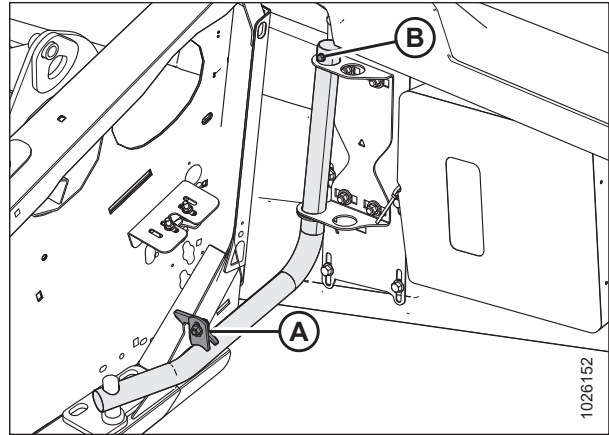

Figure 2.20: Left Endshield – Shipping Position

7. Remove fasteners securing shipping brackets (A) to endshields and remove brackets. Discard fasteners and brackets.

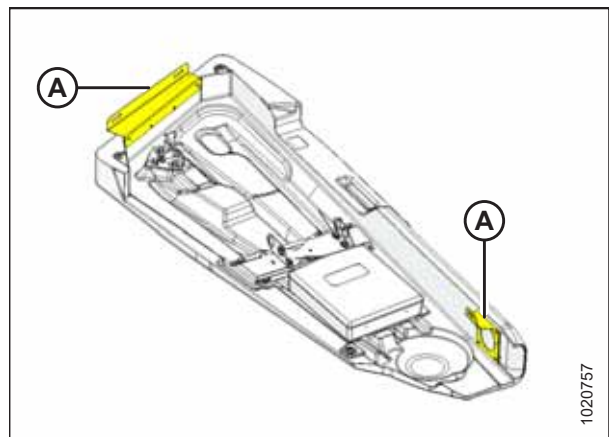

Figure 2.21: Left Endshield

8. Guide endshield onto hinge arm, using outboard holes (position 1) on bracket (C). Slowly slide the endshield downwards.
9. Install self-tapping screw (B).
10. Disengage lock (A) to allow endshield movement.

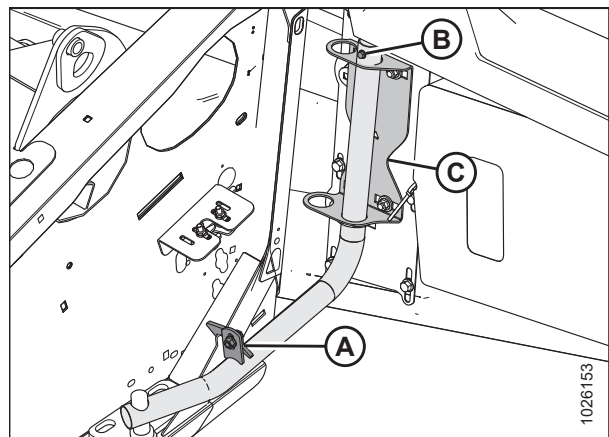

Figure 2.22: Left Endshield

## UNLOADING THE HEADER

11. Insert front of endshield behind hinge tab (A).
12. Swing endshield in direction (B) into closed position. Engage lock with a firm push.
13. Verify that endshield is locked.
14. Repeat above steps for opposite endshield.

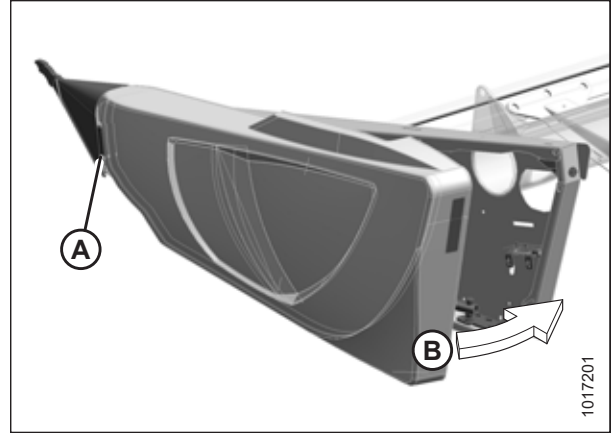

Figure 2.23: Left Endshield

15. On the outboard side of the right endsheet, remove shipping wire (A) securing divider rods (B) to the endsheet, and remove the divider rods from the shipping location.

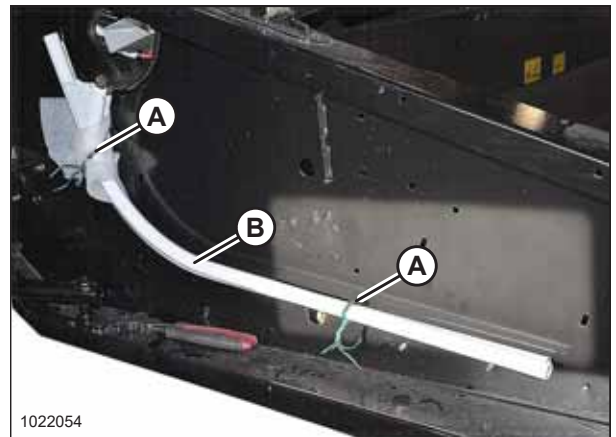

Figure 2.24: Divider Rods in Shipping Location on Header Endsheet

16. Store both crop divider rods (A) in bracket (B) as shown on the inboard side of the right side endsheet.

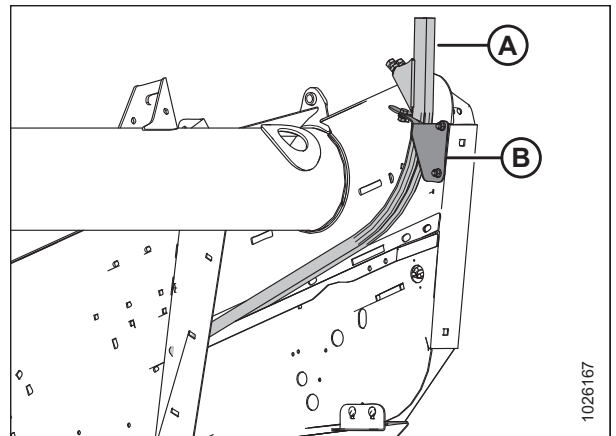

Figure 2.25: Divider Rods in Storage Location



# Chapter 3: Assembling Header and Float Module

Perform all the procedures in this chapter in the order in which they are listed.

## 3.1 Attaching Reel Lift Cylinders

### CAUTION

Tagged bolts (A) on reel arms keep the reel from sliding forward. Ensure fore-aft cylinders are attached **BEFORE** removing bolts.

### NOTE:

Reel, draper, and cutterbar parts removed from illustration for clarity.

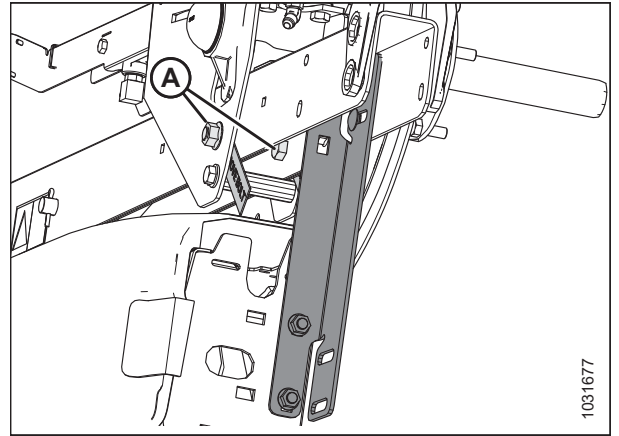

Figure 3.1: Reel Right Arm – Single Reel

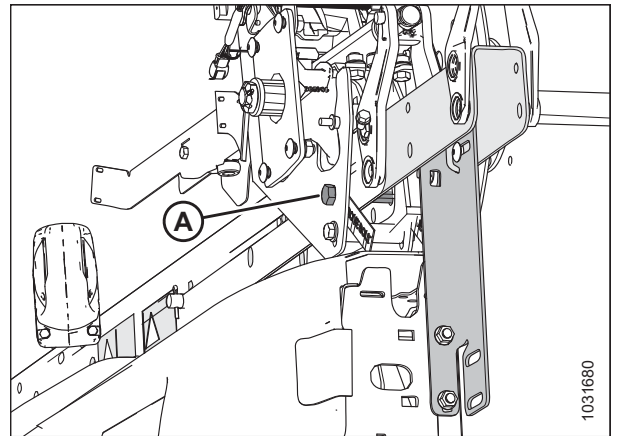

Figure 3.2: Reel Right Arm – Double Reel

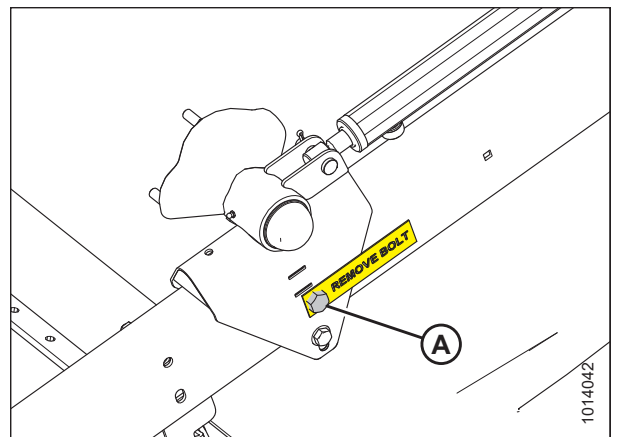

Figure 3.3: Reel Left Arm

## ASSEMBLING HEADER AND FLOAT MODULE

1. Remove two top bolts (A) on outboard reel arm support. Repeat for opposite side.

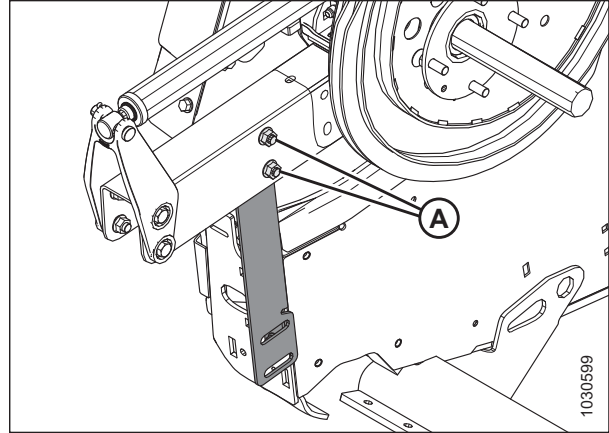

Figure 3.4: Outboard Reel Arm Support

2. **Double reel:** Remove two top bolts (A) on center reel arm to allow the center reel arm to move.

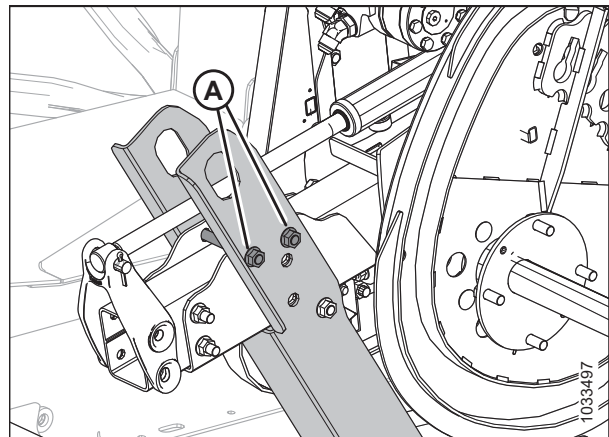

Figure 3.5: Double-Reel Center Arm

3. Position sling (A) around reel tube (B) close to the outboard end of reel and attach sling to a forklift (or equivalent).
4. Remove shipping wire/banding from the reel lift cylinder that is secured to the reel right arm.

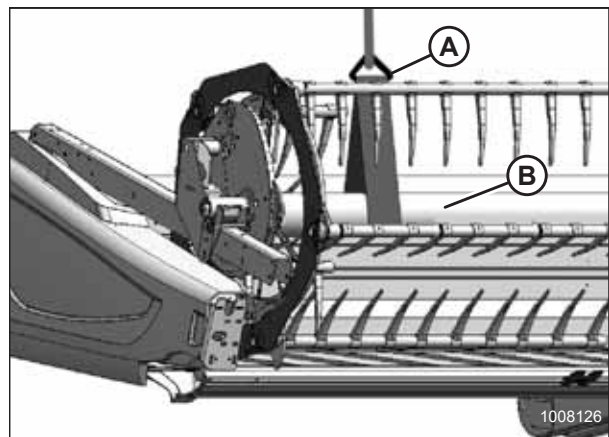

Figure 3.6: Reel Right End



## ASSEMBLING HEADER AND FLOAT MODULE

5. Lift reel and remove pins from the endsheet and the reel arm.
6. Align the reel lift cylinder mounting bolts with the lug on the endsheet and the hole in the reel arm.
7. Secure cylinder to endsheet and reel arm with clevis pins (A) and (B) as shown.
  - Insert cotter pin into clevis pin (A) on **OUTBOARD** side of reel arm.
  - Insert cotter pin into clevis pin (B) on **INBOARD** side of endsheet.

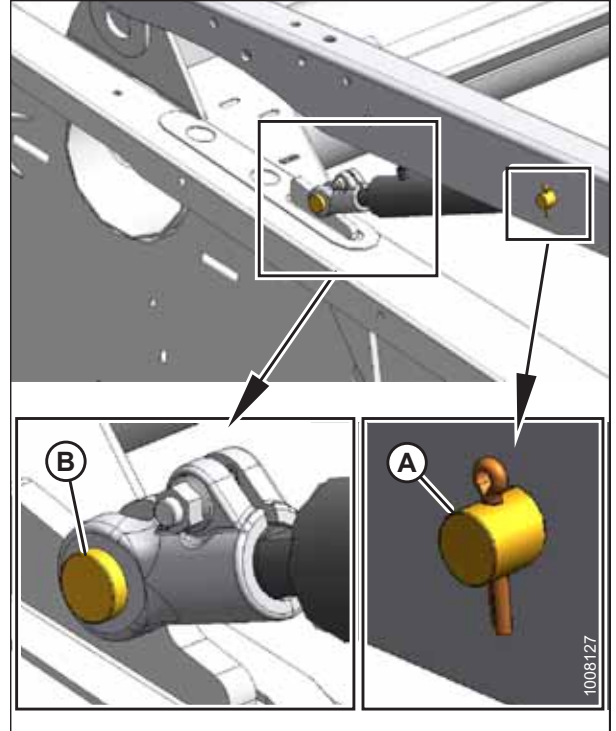

Figure 3.7: Reel Right Lift Cylinder Attachment

8. **Double reel:** Position sling (A) around the reel tube near the reel center support arm. Raise lifting device to relieve load on shipping supports (B).

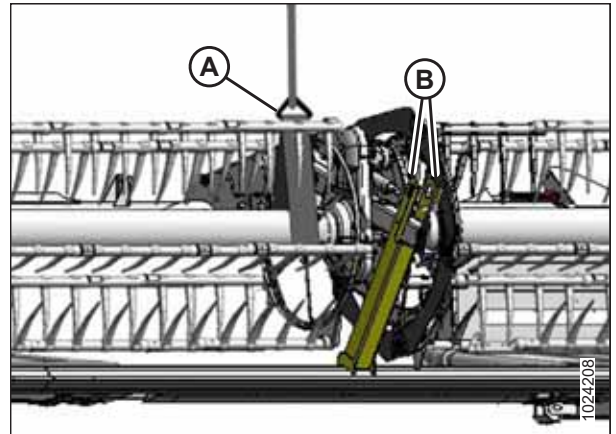

Figure 3.8: Lifting Double Reel

## ASSEMBLING HEADER AND FLOAT MODULE

9. **Double reel:** Lift reel to gain access to the center lift cylinder.
10. **Double reel:** Remove shipping wire and banding from center reel lift cylinder. Remove socket head bolt and nut from cylinder rod.
11. **Double reel:** Lift reel so that hole in center lift cylinder rod lines up with mounting hole in reel arm.
12. **Double reel:** Attach rod end of cylinder to reel arm with socket head bolt and nut (A). Access hardware through holes in reel arm braces (C).
13. **Double reel:** Torque bolt and nut (A) to 54–61 Nm (40–45 lbf·ft).
14. **Double reel:** Remove pin at barrel end of cylinder.
15. **Double reel:** Adjust reel height so pin (B) can be installed at barrel end of cylinder and mounting structure.
16. Reposition sling (A) around the reel tube near the opposite outboard reel arm.
17. Remove shipping wire and banding from the reel lift cylinder.

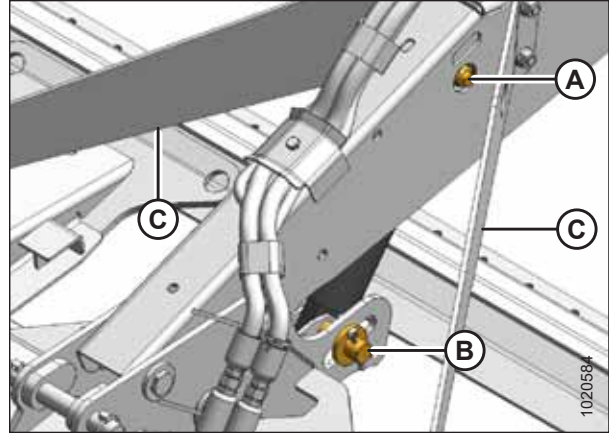

Figure 3.9: Reel Arm Braces – Double Reel

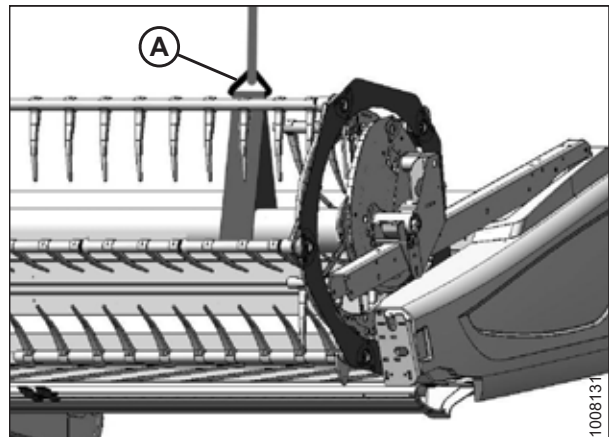

Figure 3.10: Outboard Reel Arm

## ASSEMBLING HEADER AND FLOAT MODULE

18. Lift reel and remove pins from the endsheet and the reel arm.
19. Align the reel lift cylinder mounting holes until they line up with the lug on the endsheet and the hole in the reel arm.
20. Secure cylinder to endsheet and reel arm with pins as shown.
  - Insert cotter pin into clevis pin (A) on **OUTBOARD** side of reel arm.
  - Insert cotter pin into clevis pin (B) on **INBOARD** side of endsheet.

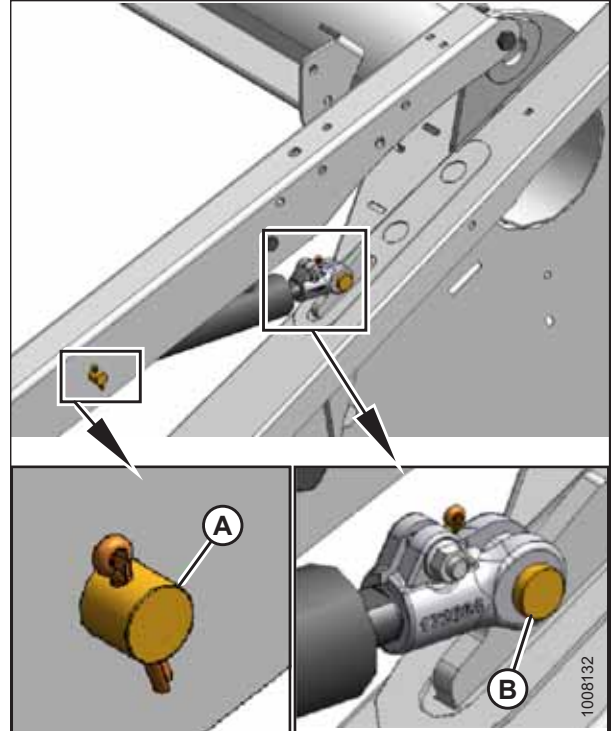

Figure 3.11: Lift Cylinder Attachment

21. **Double reel:** Remove remaining bolt (A), disengage center reel arm shipping support (B) from cutterbar, and remove shipping support.

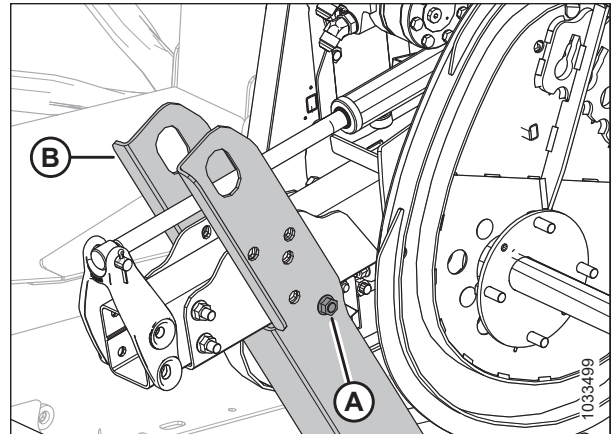

Figure 3.12: Reel Center Arm Shipping Support

## ASSEMBLING HEADER AND FLOAT MODULE

22. Remove bolts (A) from reel arm support (B) at endsheet and remove support. Repeat at other side.

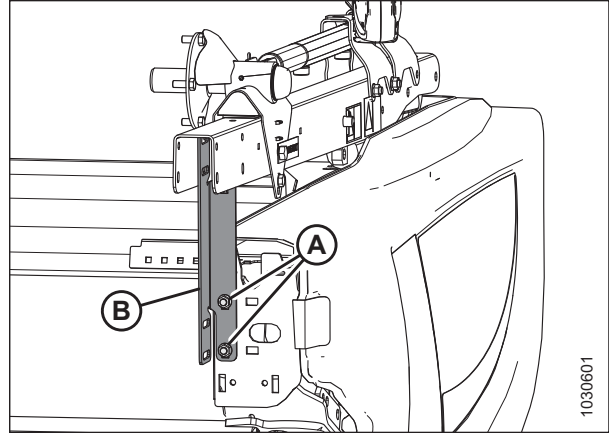

Figure 3.13: Outboard Reel Arm Supports

23. Remove brace bolts and tags (A) locking the reel fore-aft position at outer reel arms.

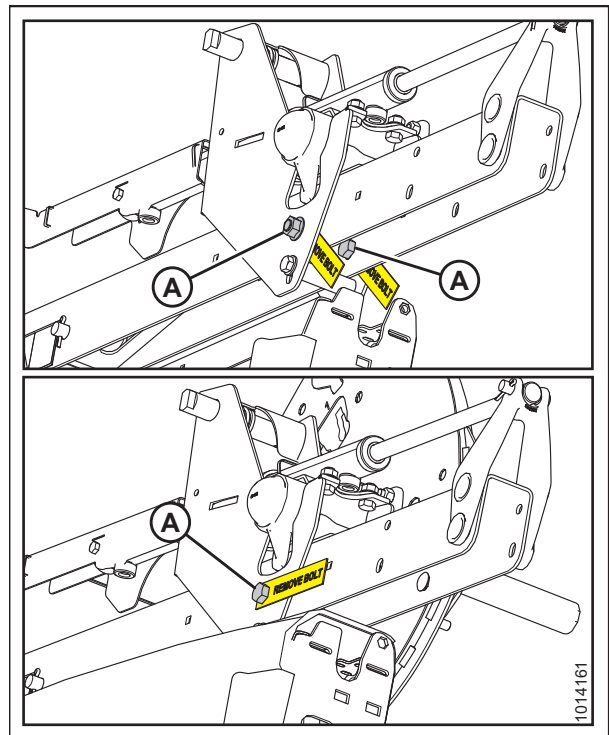

Figure 3.14: Reel Right Arm

Top Image - Single Reel

Bottom Image - Double Reel

## ASSEMBLING HEADER AND FLOAT MODULE

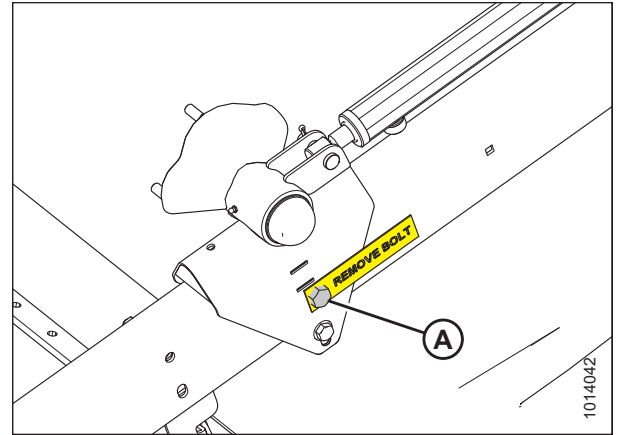

Figure 3.15: Reel Left Arm

24. **Double reel:** Remove remaining three bolts (A) locking the reel fore-aft position at the center reel arm, and remove shipping channel (B).

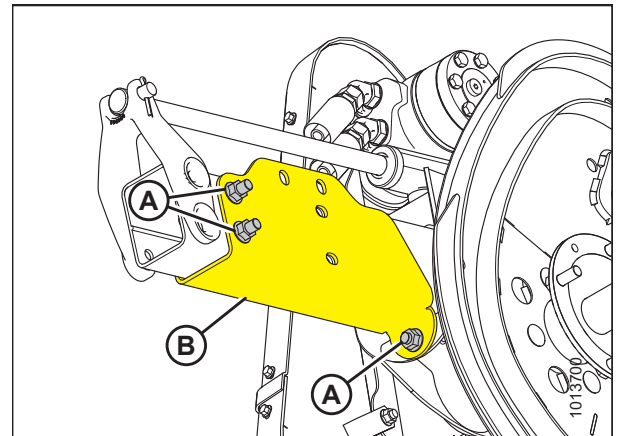

Figure 3.16: Double-Reel Center Arm Shipping Channel

### 3.2 Attaching Reel Height Sensor

The reel height sensor linkage (located toward the back of the right reel arm) is disconnected to prevent shipping damage. Reconnect the sensor using the following procedure:

1. Remove the shipping wire from sensor (A).

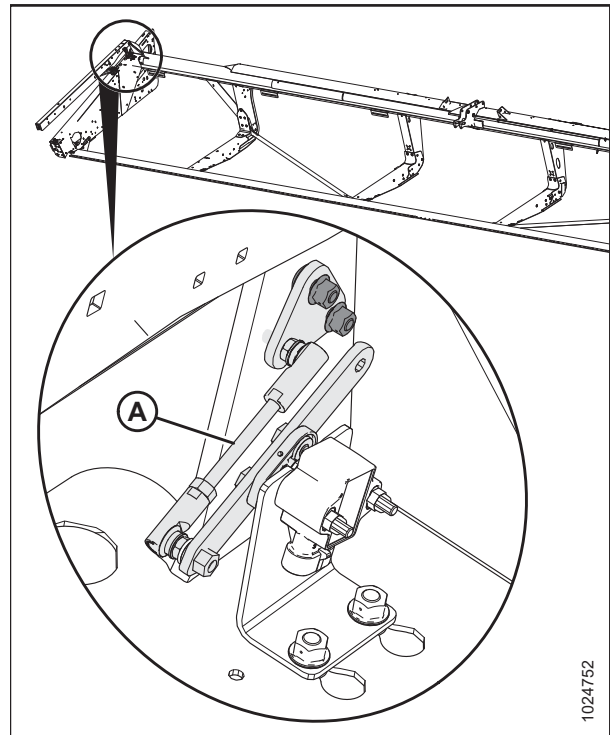
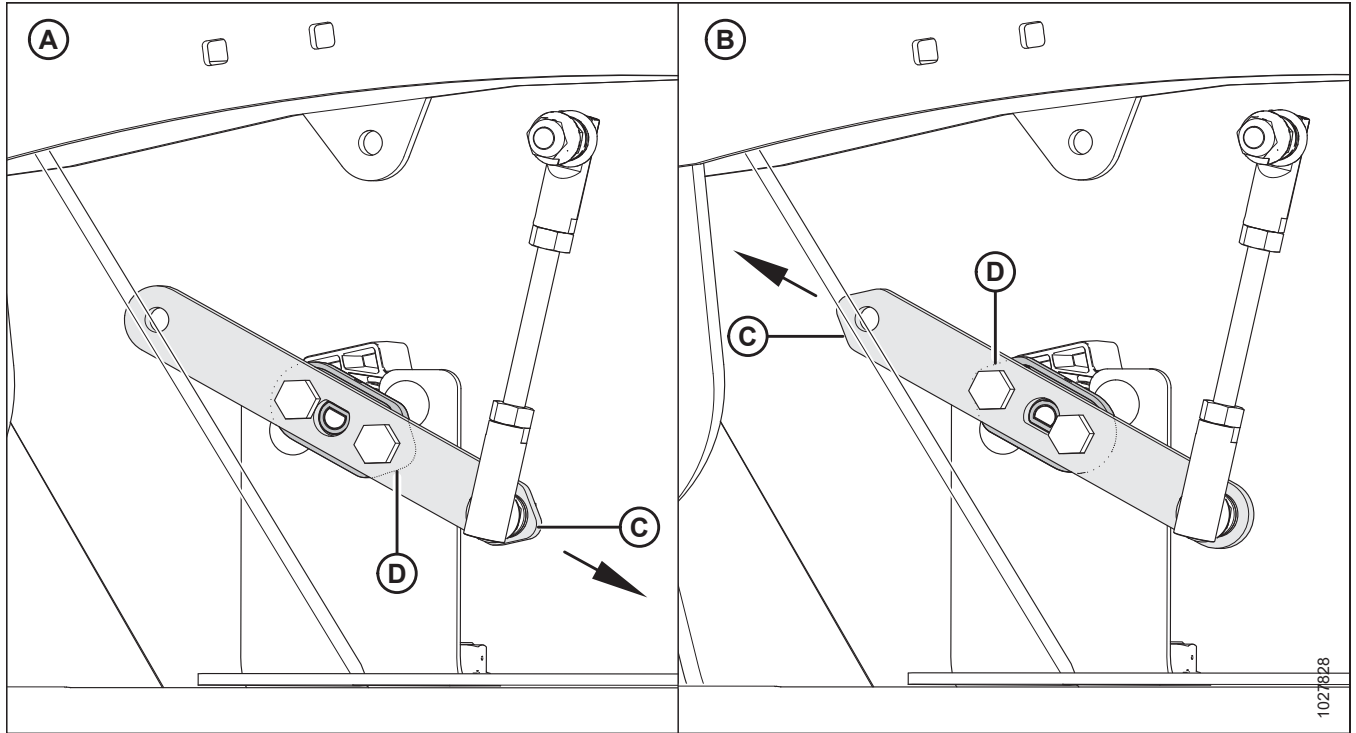

Figure 3.17: Reel Height Sensor – Disconnected

## ASSEMBLING HEADER AND FLOAT MODULE



**Figure 3.18: Sensor Arm/Pointer Configurations**

A - Case/New Holland Configuration

B - John Deere/CLAAS/AGCO IDEAL™ Configuration

C - Sensor Arm (Shown Semitransparent)

D - Sensor Pointer (Shown Under Sensor Arm)

**NOTE:**

- For configuration (A), pointer (D) points to the **FRONT** of the header.
  - For configuration (B), pointer (D) points to the **REAR** of the header.
  - Sensor arm made semitransparent to show sensor pointer behind it.
2. Check that sensor arm (C) and pointer (D) are configured properly for your combine. For instructions, refer to [Figure 3.18, page 27](#).

## ASSEMBLING HEADER AND FLOAT MODULE

3. Attach reel height sensor plate (A) to reel arm with existing bolts and nuts (B). Torque to 8.2 Nm (6 lbf-ft).

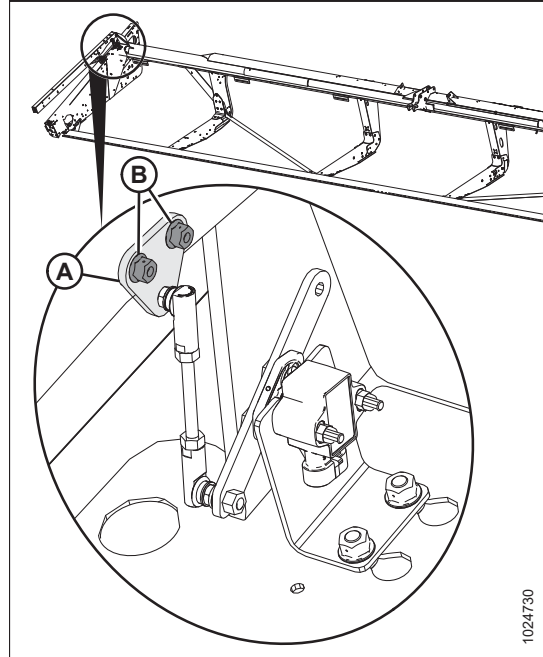

Figure 3.19: Reel Height Sensor



### 3.3 Attaching Cam Arms

To attach the reel cam arms, follow these steps:

1. Rotate the reel manually until the tine bars with disconnected cam links are accessible.
2. Remove shipping wire (A) (if not already removed).

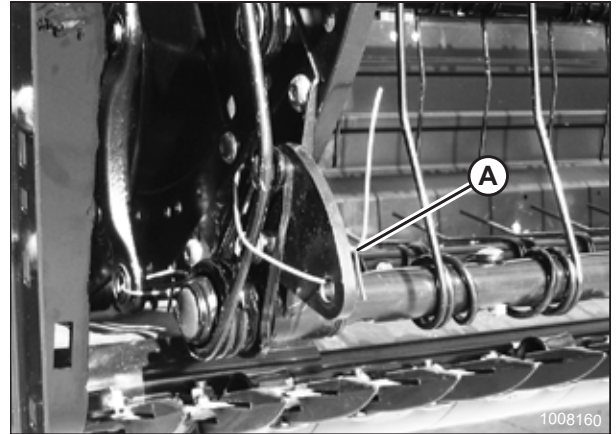

Figure 3.20: Disconnected Cam Links and Shipping Wire

3. Remove bag of hardware (A) from tine bar. It contains hardware for cam links and endshields.

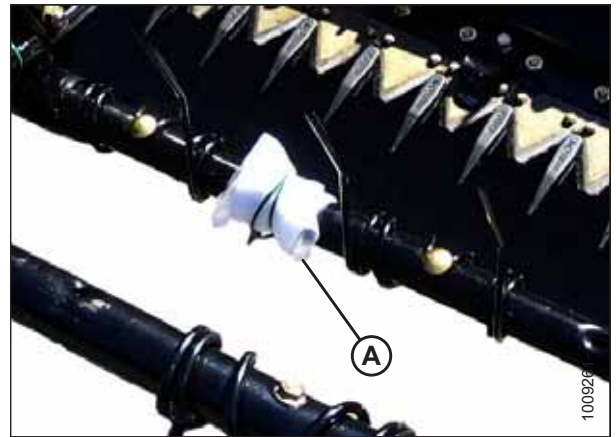

Figure 3.21: Hardware Bag Right Reel

4. Rotate tine bar crank (A) and position link (B) so attachment holes in bar crank are aligned with hole in link.
5. Install bolt (C) in link and position shim (D) on bolt so that shim is **BETWEEN** link (B) and tine bar crank (A).

**IMPORTANT:**

Make sure shim (D) is installed in the correct location to avoid damage to the bar crank.

**NOTE:**

Bolts are precoated with Loctite®, so no further locking method is required.

6. Realign link (B) and tine bar crank (A) and thread in bolt (C).
7. Repeat for remaining tine bars and torque bolts to 165 Nm (120 lbf-ft).

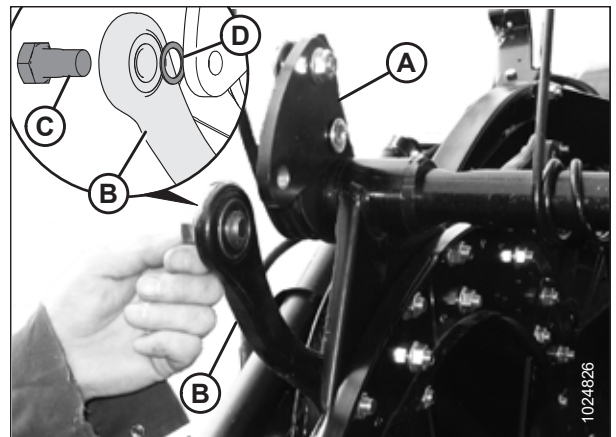

Figure 3.22: Bar Crank Attachment Holes and Link Alignment

## ASSEMBLING HEADER AND FLOAT MODULE

8. Position reel pitch at position 4 to access bolt (A) after rotating the reel. Reposition reel to position 2 when done.

**NOTE:**

This procedure is done only on the right reel.

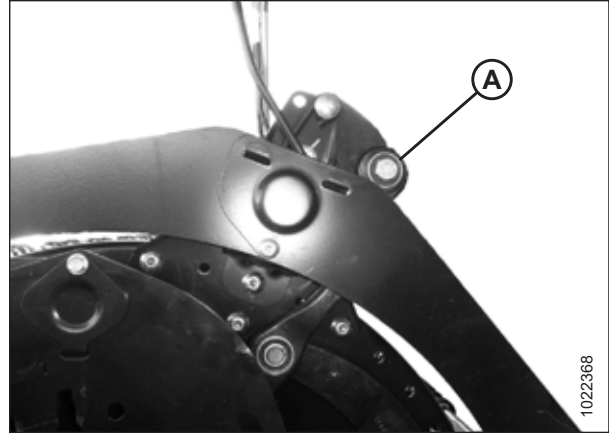

Figure 3.23: Right Reel with Cam Arms Attached

### 3.4 Repositioning Gearbox

To reposition the gearbox, follow these steps:

1. Remove shipping wire and wrapping on brace (A). Swing brace clear of gearbox.

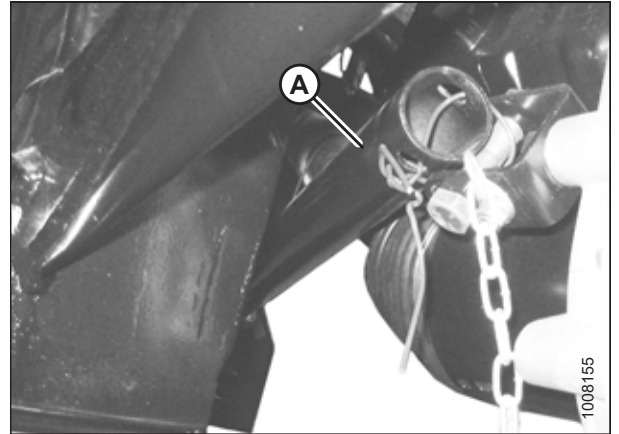

Figure 3.24: Shipping Wire and Brace

2. Loosen nut (A) and move bolt out of shipping position slot.

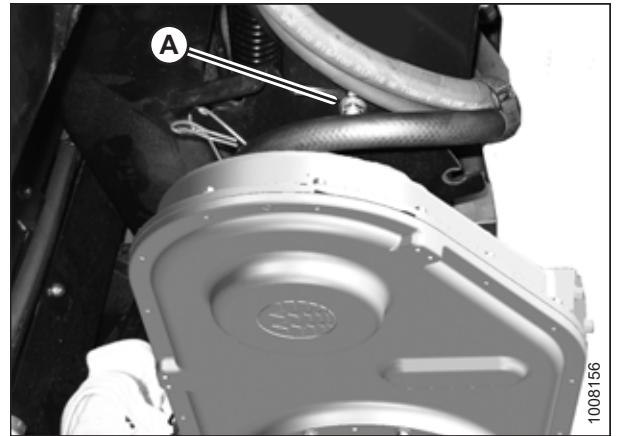

Figure 3.25: Shipping Position

3. Rotate gearbox and insert bolt into working position slot (A). Tighten nut.
4. Tighten suction hose clamp (B) to 6.4–7.0 Nm (57–62 lbf·in).

**NOTE:**

Hose clamps should be readjusted after running with hot oil.

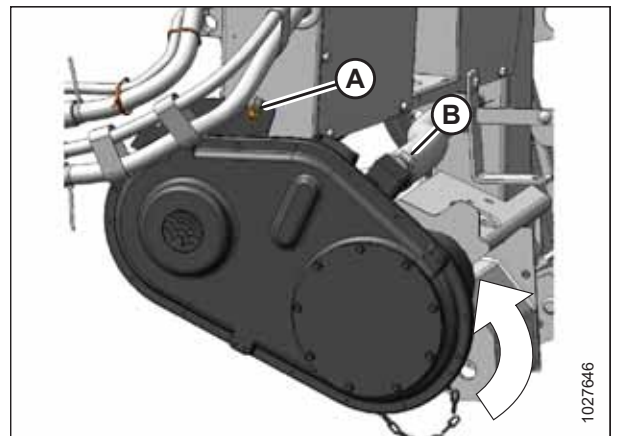

Figure 3.26: Working Position

## ASSEMBLING HEADER AND FLOAT MODULE

5. Remove bolt (C) and nut from bracket on gearbox.
6. Position brace (A) inside bracket (B), and reinstall bolt (C) and nut.

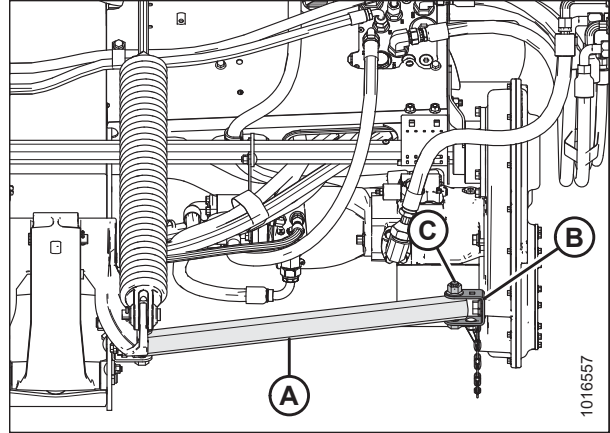

Figure 3.27: Brace Position

### 3.5 Installing Driveline

#### CAUTION

To prevent injury to the installer and damage to the driveline, hold the driveline so that it doesn't fall to the floor or ground.

#### NOTE:

Case New Holland drivelines are stored in a lower position on the float module. If installing a Case New Holland driveline, proceed to Step 2, [page 33](#).

1. Position driveline storage support (A) onto the left frame of the float module. Secure in place with two M10 carriage bolts and hex flange nuts (B).

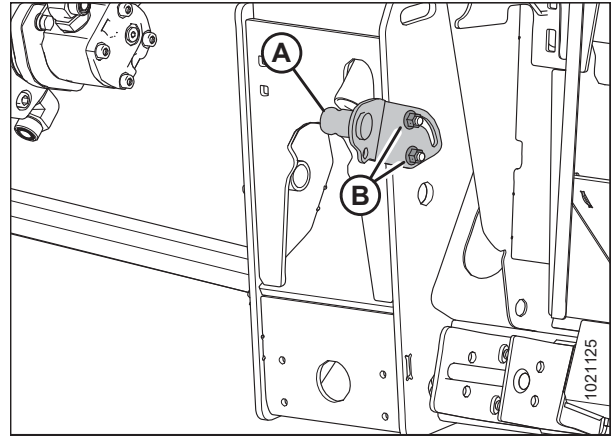

Figure 3.28: Driveline Support

2. **Case New Holland only:** Position driveline storage support (A) onto left side of bracket (B) as shown. Secure in place with two M12 hex head bolts (C) and hex flange nuts.

#### NOTE:

The support for 21-tooth spline drivelines is shown in the illustration at right. The support for 6-tooth spline drivelines is similar.

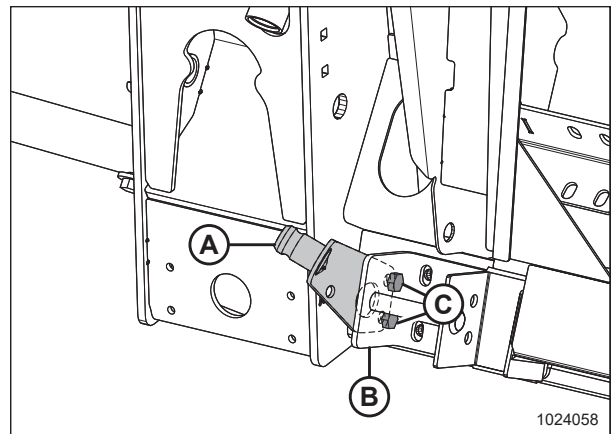

Figure 3.29: Driveline Support – Case New Holland

## ASSEMBLING HEADER AND FLOAT MODULE

3. At gearbox end, remove driveline shield (A) by loosening nuts (B).
4. Position the driveline quick disconnect onto the float module gearbox shaft, pull back the collar, and slide onto the shaft until the yoke locks on to the shaft. Release the collar.

### NOTE:

The arrow on the driveline sticker should point toward the combine.

5. Position shield (A) on the gearbox and secure with bolts (B).
6. Attach driveline chain (C) to existing chain on shield (A).

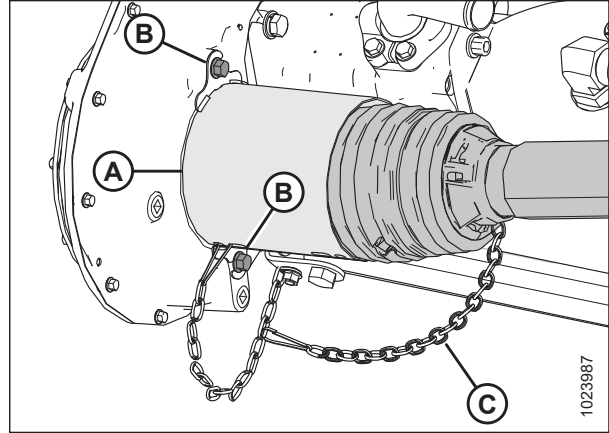

Figure 3.30: Gearbox End of Driveline

7. Position the combine end of driveline (A) onto storage support (B), pull back the collar, and slide onto the shaft until the yoke locks on to the shaft. Release the collar.
8. Secure loose end of driveline chain (C) to driveline storage support (B).

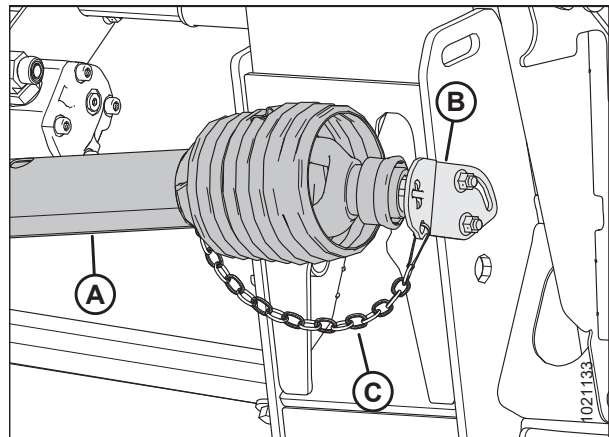

Figure 3.31: Driveline in Storage Position

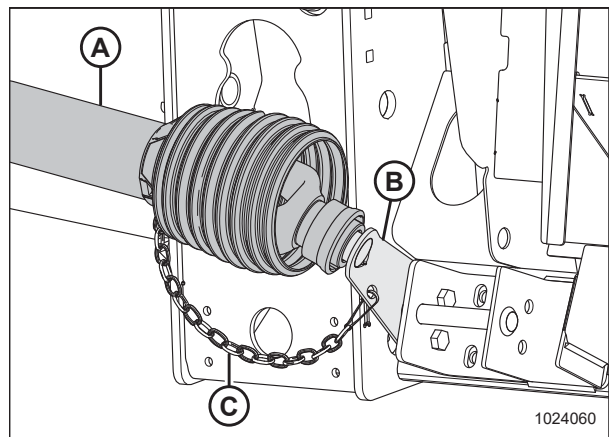

Figure 3.32: Driveline in Storage Position –  
Case New Holland

## Chapter 4: Setting up Float Module at Dealer

Complete the following procedures in the order in which they are listed:

- [4.1 Installing Filler Cap, page 35](#)
- [4.2 FM100 Feed Auger Configurations, page 38](#)
- [4.3 FM100 Stripper Bars and Feed Deflectors, page 80](#)

### 4.1 Installing Filler Cap

1. Remove filler cap from bag (A).

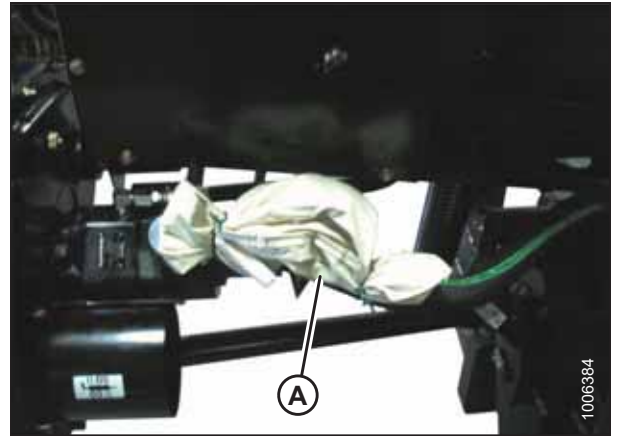

Figure 4.1: Hardware Bag

#### CAUTION

Fluid may be under pressure. Allow pressure to equalize by loosening screws and lifting the shipping cover slightly.

2. Remove yellow shipping cover (A) from the float module frame. Discard cover. Keep screws if screws are not supplied with filler cap.

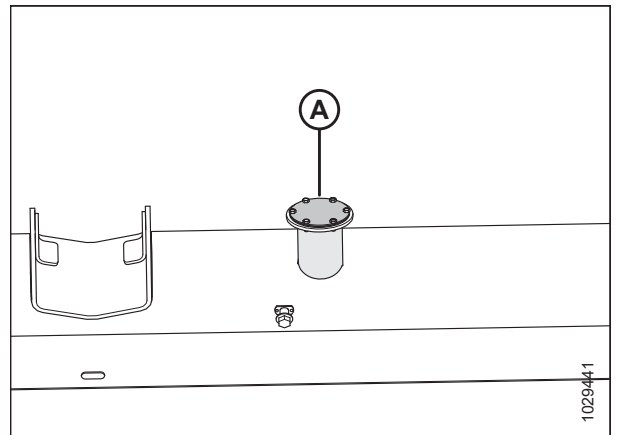

Figure 4.2: Yellow Shipping Cover

## SETTING UP FLOAT MODULE AT DEALER

3. Remove top gasket (A) for use in the next step.

**NOTE:**

There are two gaskets—one on each side of the filler strainer flange.

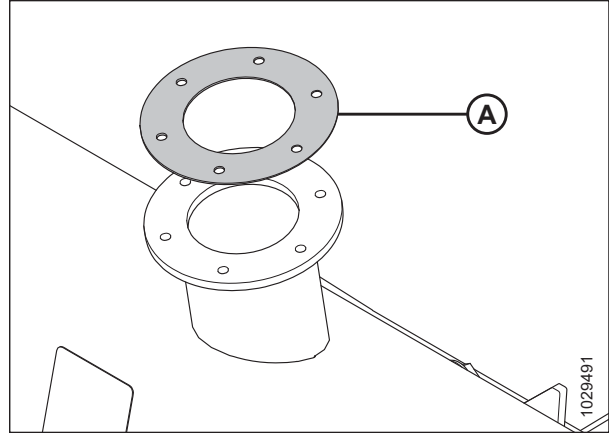

Figure 4.3: Top Gasket

4. Place gasket (A) (removed from the top of the filler strainer) onto filler cap neck (B) and align holes.
5. Install #10-32 screws (if supplied with cap, otherwise use existing screws) into filler cap neck (B) and push screws through gasket (A).

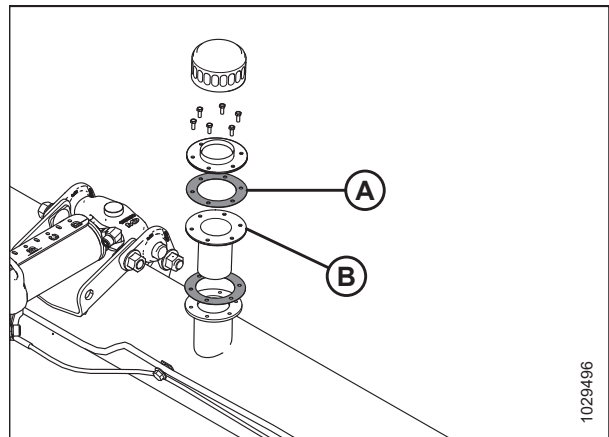

Figure 4.4: Filler Cap Neck

6. Place filler cap neck (A) (complete with screws) over opening and ensure the machine screws are aligned with the threaded holes.
7. Carefully thread in the machine screws using a cross pattern (as shown) in order to prevent cross threading of tapped holes.
8. Repeat pattern to gradually tighten screws to 3.5 Nm (31 lbf·in).

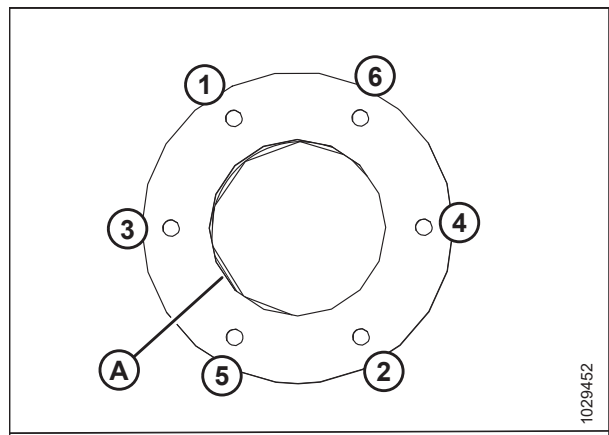

Figure 4.5: Screw Hole Locations



## SETTING UP FLOAT MODULE AT DEALER

9. Install filler cap (A).

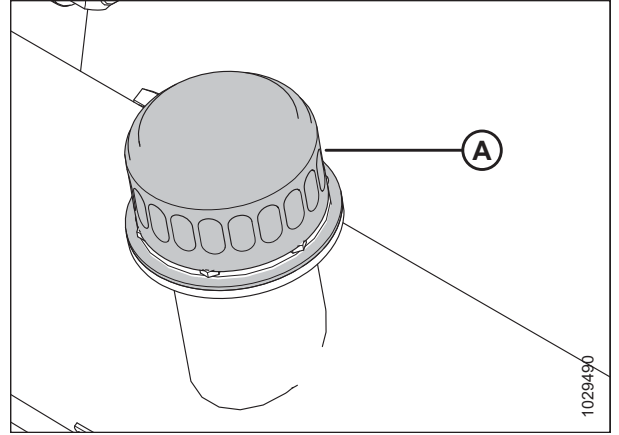

Figure 4.6: Filler Cap

## 4.2 FM100 Feed Auger Configurations

The FM100 feed auger can be configured to suit various crop conditions; there are five configurations available.

**NOTE:**

Dimensions (A) and (B) are the same for both ends of the auger. They should be within 15 mm (9/16 in.) of the numbers given.

**Narrow configuration** is a standard configuration for the following combines:

- AGCO IDEAL™ Series
- Gleaner R6/75, R6/76, S6/77, S6/7/88, S96/7/8
- New Holland CR 920/940/960, 9020/40/60/65, 6090/7090, 8060/8070/8080

Narrow configuration uses 4 long bolt-on flightings (2 on the left and 2 on the right) and 18 feed auger fingers are recommended.

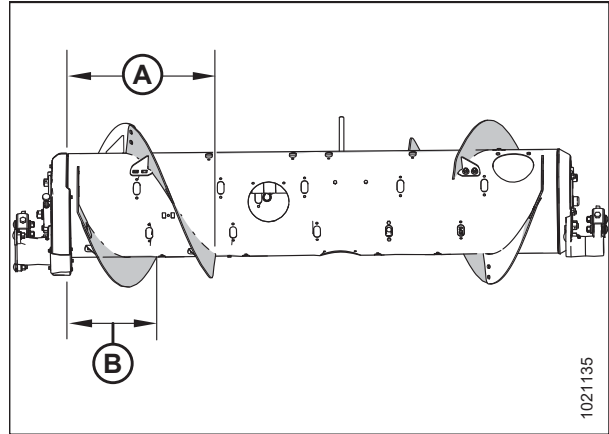

**Figure 4.7: Narrow Configuration – Rear View**  
 A - 514 mm (20 1/4 in.)      B - 356 mm (14 in.)

**To convert to Narrow configuration from Medium or Wide configuration**, refer to [4.2.3 Converting from Medium Configuration or Wide Configuration to Narrow Configuration, page 47](#).

**To convert to Narrow configuration from Ultra Narrow configuration**, refer to [4.2.4 Converting from Ultra Narrow Configuration to Narrow Configuration, page 51](#).

**NOTE:**

Dimensions (A) and (B) are the same for both ends of the auger. They should be within 15 mm (9/16 in.) of the numbers given.

**Medium configuration** is a standard configuration for the following combines:

- Case IH 2300/2500 Series
- Case IH 5/6/7088, 7/8010, 7/8/9120, 5/6/7130, 7/8/9230, 5/6/7140, 7/8/9240, 5/6/7150, 7/8/9250
- Challenger 66/67/680B, 54/560C, 54/560E
- CLAAS 56/57/58/590R, 57/58/595R, 62/63/64/65/66/670, 73/74/75/76/77/780, 7000/8000, Tucano
- John Deere 95/96/97/9860, 95/96/97/9870, S65/66/67/68/690, T670, S76/77/78/790
- Massey Ferguson 96/97/9895, 9520/40/60, 9545/65, 9380
- New Holland CR 970/980, 9070/9080, 8090/9090, X.90, X.80, 10.80/10.90
- New Holland CX 8X0, 80X0, 8.X0, 8080/8090
- Rostselmash Torum 760/780
- Versatile RT490

**Medium configuration** is an optional configuration for AGCO IDEAL™ Series.

Medium configuration uses 4 short bolt-on flightings (2 on the left and 2 on the right) and 22 feed auger fingers are recommended.

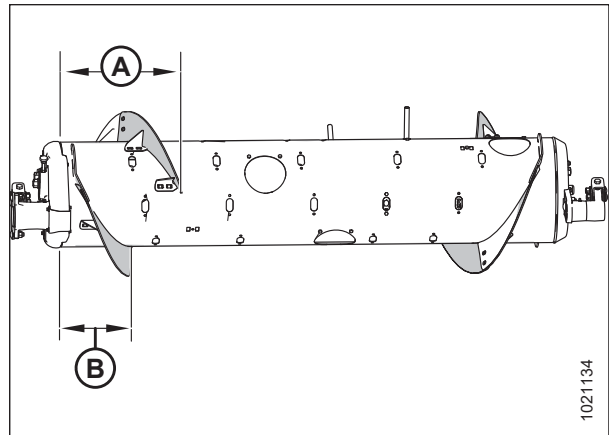

**Figure 4.8: Medium Configuration – Rear View**  
 A - 410 mm (16 1/8 in.)      B - 260 mm (10 1/4 in.)

## SETTING UP FLOAT MODULE AT DEALER

To convert to **Medium configuration** from **Narrow or Ultra Narrow configuration**, refer to [4.2.1 Converting from Ultra Narrow Configuration or Narrow Configuration to Medium Configuration, page 41](#).

To convert to **Medium configuration** from **Wide configuration**, refer to [4.2.2 Converting from Wide Configuration to Medium Configuration, page 45](#).

### NOTE:

Dimensions (A) and (B) are the same for both ends of the auger. They should be within 15 mm (9/16 in.) of the numbers given.

**Wide configuration** is an optional configuration for the following combines:

- Challenger 670B/680B, 540C/560C, 540E/560E
- CLAAS 590R/595R, 660/670, 760/770/780, 8000
- John Deere T670
- Massey Ferguson 9895, 9540, 9560, 9545, 9565, 9380
- New Holland CX 8X0, 80X0, 8.X0

Wide configuration uses 2 short bolt-on flightings (1 on the left and 1 on the right) and 30 feed auger fingers are recommended.

### NOTE:

This configuration may increase combine capacity on wide feeder house combines in certain crop conditions.

To convert to **Wide configuration** from **Medium configuration**, refer to [4.2.5 Converting from Medium Configuration to Wide Configuration or Ultra Wide Configuration, page 52](#).

To convert to **Wide configuration** from **Ultra Narrow or Narrow configuration**, refer to [4.2.6 Converting from Ultra Narrow or Narrow Configuration to Wide Configuration, page 57](#).

### NOTE:

Dimensions (A) and (B) are the same for both ends of the auger. They should be within 15 mm (9/16 in.) of the numbers given.

**Ultra Narrow configuration** is an optional configuration that may improve feeding performance on combines with narrow feeder houses. It may also be helpful when harvesting rice.

Ultra Narrow configuration uses 8 long bolt-on flightings (4 on the left and 4 on the right) and 18 auger fingers are recommended.

### NOTE:

You will need to drill holes in the flighting and in the drum to install the extra flighting.

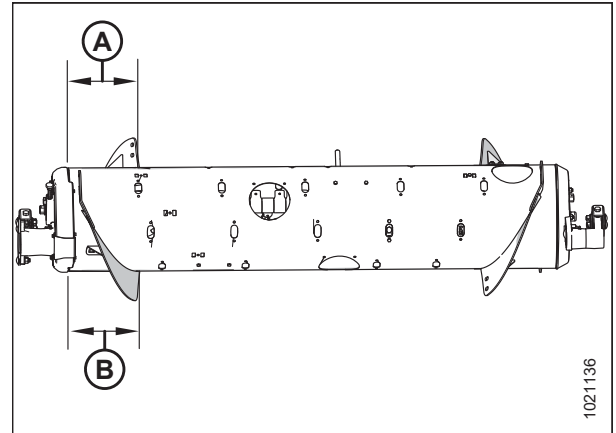

**Figure 4.9: Wide Configuration – Rear View**

A - 257 mm (10 1/8 in.)

B - 257 mm (10 1/8 in.)

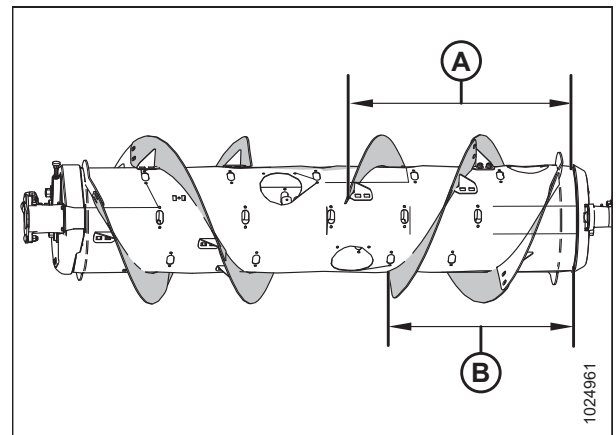

**Figure 4.10: Ultra Narrow Configuration – Rear View**

A - 760 mm (29 15/16 in.)

B - 602 mm (23 11/16 in.)

To convert to **Ultra Narrow configuration** from **Medium or Wide configuration**, refer to [4.2.9 Converting from Medium Configuration or Wide Configuration to Ultra Narrow Configuration, page 66](#).

To convert to **Ultra Narrow configuration** from **Narrow configuration**, refer to [4.2.10 Converting from Narrow Configuration to Ultra Narrow Configuration, page 73](#).

## SETTING UP FLOAT MODULE AT DEALER

**Ultra Wide configuration** is an optional configuration for the following combines:

- CLAAS 590R/595R, 660/670, 760/770/780/7000/8000

The Ultra Wide configuration uses no bolt on flighting; only the factory-welded flighting (A) is responsible for conveying the crop.

**NOTE:**

This configuration may improve feeding for wide feeder house combines.

A total of 30 auger fingers are recommended for this configuration.

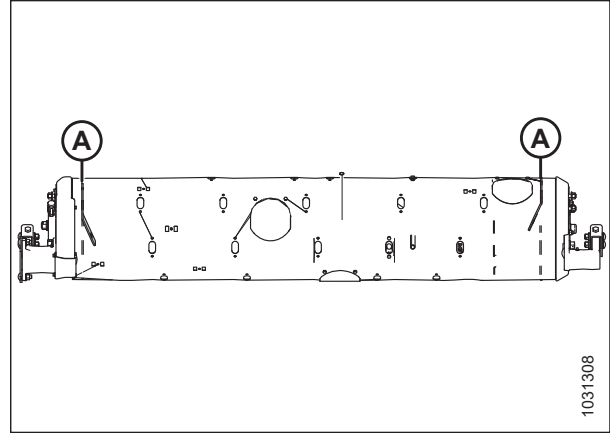

**Figure 4.11: Ultra Wide Configuration – Rear View**

**To convert to Ultra Wide configuration from Ultra Narrow or Narrow configuration,** refer to [4.2.7 Converting from Ultra Narrow or Narrow Configuration to Ultra Wide Configuration, page 61](#).

**To convert to Ultra Wide configuration from Medium configuration,** refer to [4.2.5 Converting from Medium Configuration to Wide Configuration or Ultra Wide Configuration, page 52](#).

**To convert to Ultra Wide configuration from Wide configuration,** refer to [4.2.8 Converting from Wide Configuration to Ultra Wide Configuration, page 64](#).

### 4.2.1 Converting from Ultra Narrow Configuration or Narrow Configuration to Medium Configuration

Two flighting kits (MD #287031) are required to convert to this configuration.

Ultra Narrow, Narrow, and Medium auger configurations are shown at right. When converting from Ultra Narrow configuration or Narrow configuration to Medium configuration, you will need to replace long flightings (A) with short flightings (B).

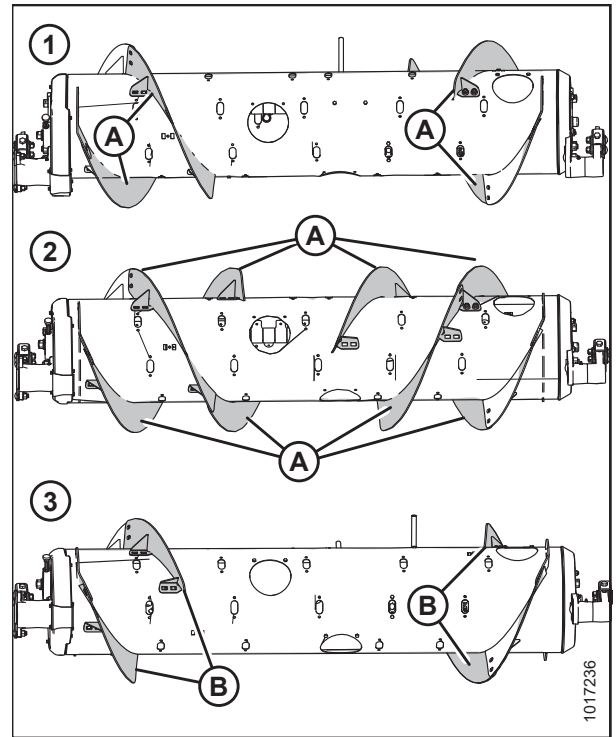

Figure 4.12: Auger Configurations – Rear View

- 1 - Narrow Configuration
- 2 - Ultra Narrow Configuration
- 3 - Medium Configuration

**NOTE:**

Some parts have been removed from the illustrations for clarity.

1. To improve access and ease installation, remove the float module from the combine. For instructions, refer to the header operator’s manual or technical manual.
2. Remove bolts (A) and access cover (B) from each side of the auger. Retain for reassembly.

**NOTE:**

If necessary, remove multiple access covers.

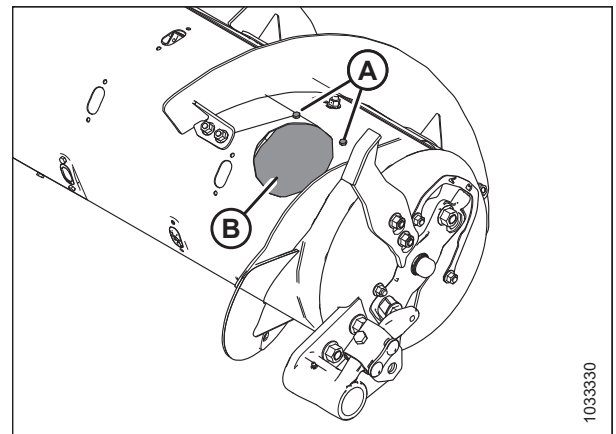

Figure 4.13: Narrow Configuration – Right Side

SETTING UP FLOAT MODULE AT DEALER

- 4. **Converting from Ultra Narrow Configuration:** Remove hardware (A) from the four most inboard flightings (B).

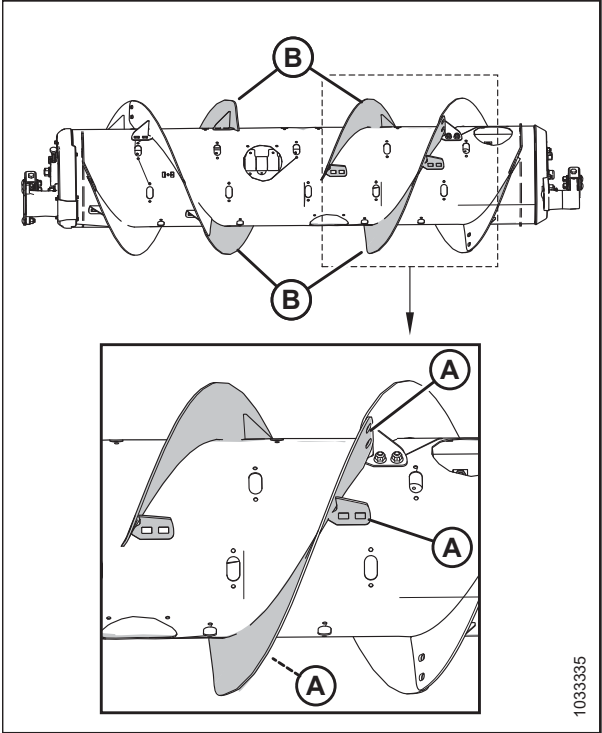

Figure 4.14: Ultra Narrow Configuration

- 5. On the **RIGHT** side of the auger, remove bolt and nut from locations (A) and (B). Remove bolt-on flightings (C). Leave hardware installed at location (D) to keep the magnetic reverser shield (E) secured to the drum. Remove the one flighting slot plug from location (F).

**NOTE:**

On the **RIGHT** side of the auger, a bolt and nut at locations (B) and (D) attach magnetic reverser shield (E) to the drum and flighting. Keep bolts and nuts from locations (B) and (D) separate from the rest of the retained hardware because these bolts are slightly longer. Whenever modifying or servicing the auger, keep at least one side of the reverser shield attached to the drum if possible. A completely detached reverser shield is more difficult to install because the shield is magnetically attracted to the drum. There is only one magnetic reverser shield in the drum.

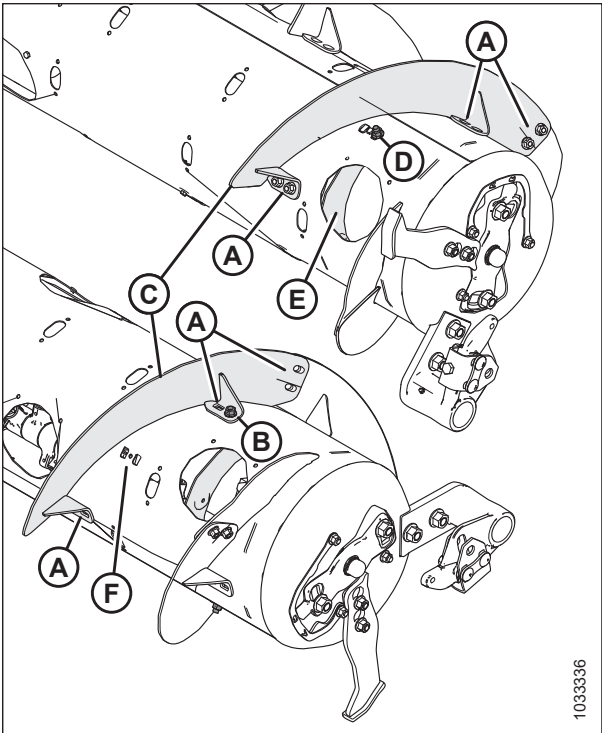

Figure 4.15: Narrow Configuration – Right Side of Auger

## SETTING UP FLOAT MODULE AT DEALER

6. On the **RIGHT** side of the auger, note the position of auger pivot (A) to distinguish between flightings (B) and (C).

**NOTE:**

On the **RIGHT** side of the auger, a bolt and nut at locations (D) and (E) attach magnetic reverser shield (F) to the drum and flightings.

Install flighting (B) using bolts and nuts at locations (G). Reinstall the longer bolt and nut at location (D) to secure magnetic reverser shield (F) to the drum and flightings.

**IMPORTANT:**

Flighting bolt heads must be installed on the inside of the auger to prevent damaging internal components.

Remove longer bolt and nut from location (E). This bolt and nut attach the other side of the magnetic reverser shield to the drum.

Install flighting using bolts and nuts at locations (H).

Reinstall longer bolt and nut at location (E).

7. Torque all nuts and bolts attaching the flighting and the magnetic reverser shield to 47 Nm (35 lbf-ft) to eliminate deflection on the flighting, then retorque them to 61 Nm (45 lbf-ft).

**NOTE:**

Flighting performs best when no gaps are present. If desired, use silicone sealant to fill the gaps.

8. Install flighting slot plugs at locations (J) and secure with M6 bolts and tee nuts. Torque to 9 Nm (80 lbf-in).

**NOTE:**

If plug bolts are **NOT** new, coat bolts with medium-strength threadlocker (Loctite® 243 or equivalent) prior to installation.

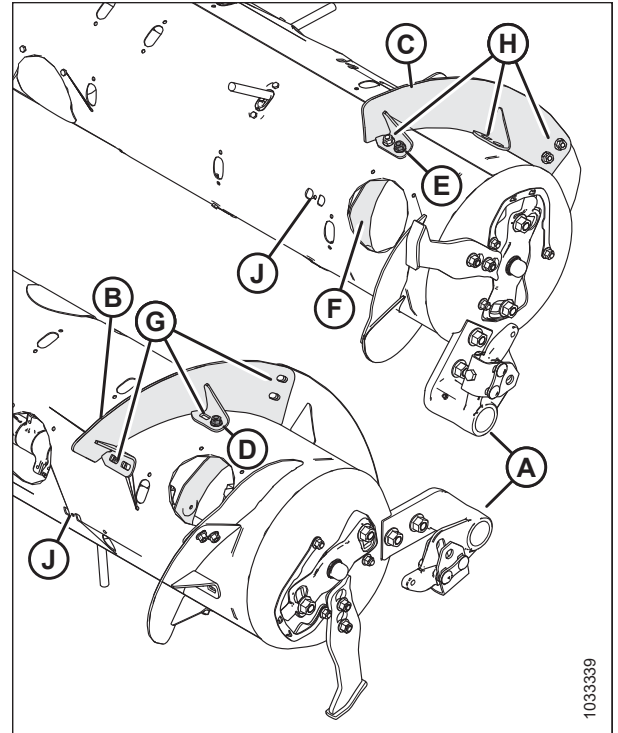

Figure 4.16: Medium Configuration – Right Side

## SETTING UP FLOAT MODULE AT DEALER

9. On the **LEFT** side of the auger, remove bolt and nut from locations (A). Remove two bolt-on flightings (B). Remove flighting slot plugs from locations (C).

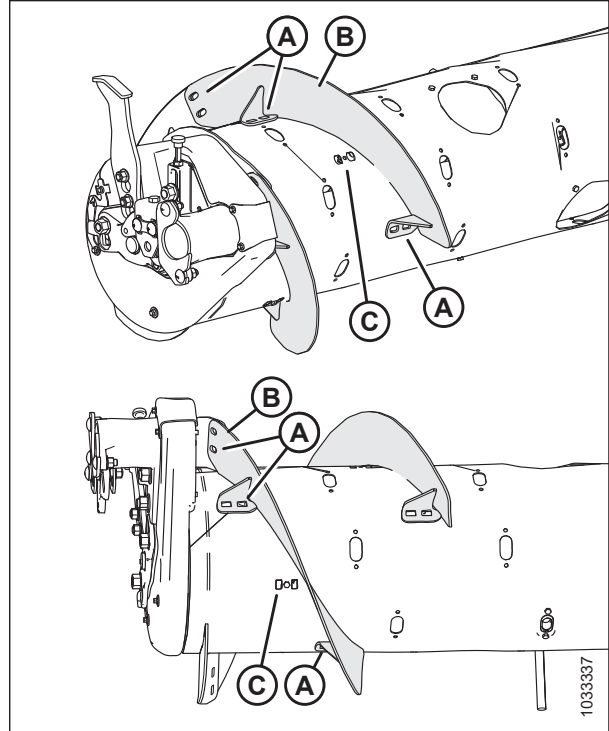

Figure 4.17: Narrow Configuration – Left Side of Auger

10. On the **LEFT** side of the auger, install flightings (B) using bolts and nuts at locations (A).

### IMPORTANT:

Flighting bolt heads must be installed on the inside of the auger to prevent damaging internal components.

11. Torque all nuts and bolts attaching the flighting to 47 Nm (35 lbf-ft) to eliminate deflection on the flighting, then retorque them to 61 Nm (45 lbf-ft).

### NOTE:

Flighting performs best when no gaps are present. If desired, use silicone sealant to fill the gaps.

12. Install flighting slot plugs at locations (C) and secure with M6 bolts and tee nuts. Torque to 9 Nm (80 lbf-in).

### NOTE:

If plug bolts are **NOT** new, coat bolts with medium-strength threadlocker (Loctite® 243 or equivalent) prior to installation.

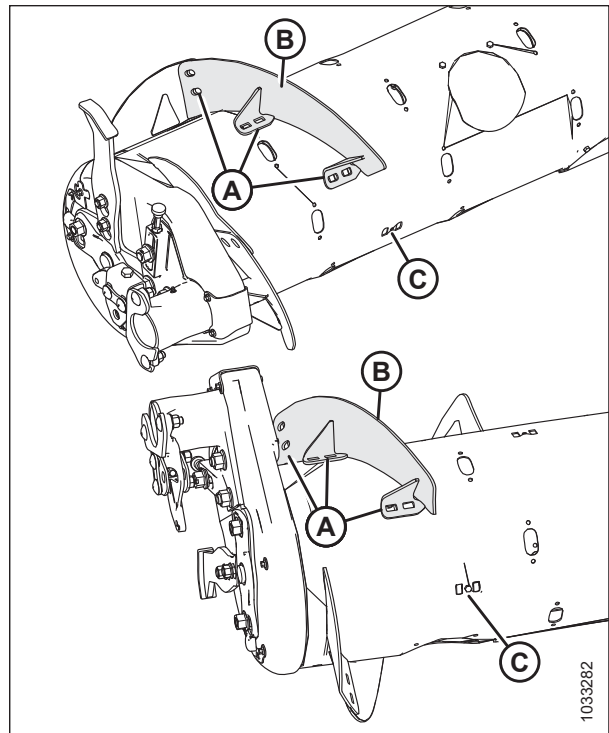

Figure 4.18: Medium Configuration – Left Side

13. Install additional auger fingers. A total of 22 auger fingers is recommended for this configuration. For instructions, refer to [4.2.11 Installing Feed Auger Fingers, page 75](#).



## 4.2.2 Converting from Wide Configuration to Medium Configuration

One flighting kit (MD #287031) is required to convert the feed auger from Wide configuration to Medium configuration.

Wide and Medium auger configurations are shown at right. When converting from Wide configuration to Medium configuration, you will need to install new flightings (A).

**NOTE:**

All illustrations show the feed auger separated from the float module for clarity. The procedure can be performed with the feed auger installed in the float module.

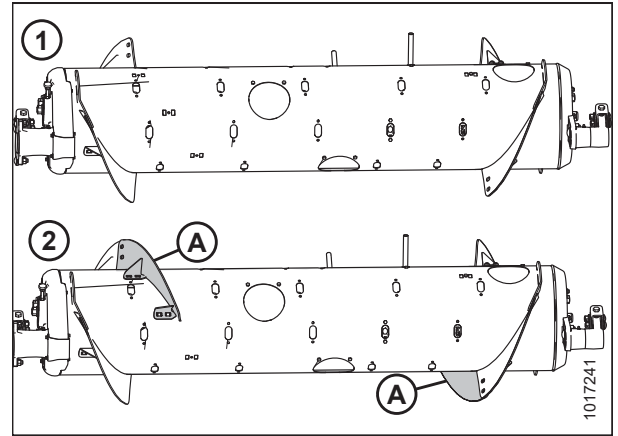
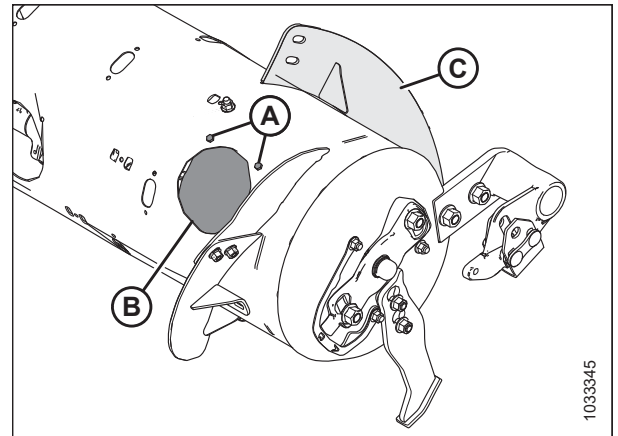

**Figure 4.19: Auger Configurations – Rear View**  
1 - Wide Configuration      2 - Medium Configuration

1. Improve access and ease installation by removing the float module from the combine. For instructions, refer to the header operator's manual or technical manual.
2. Remove bolts (A) and remove access cover (B) from the right and left sides of the auger. Retain for reassembly.

**NOTE:**

On the right side of the auger, remove the access cover closest to the end of flighting (C) that does **NOT** have bolt-on flighting attached to it.

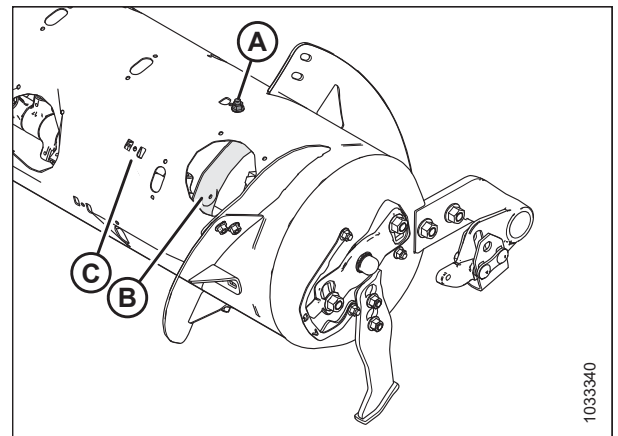

**Figure 4.20: Wide Configuration – Right Side**

3. On the **RIGHT** side of the auger, remove bolt and nut from location (A) that secures magnetic reverser shield (B) to the drum. Remove flighting slot plug from location (C).

**NOTE:**

Keep bolt and nut from location (A) separate from other hardware used to attach flightings because this bolt is slightly longer.



**Figure 4.21: Wide Configuration – Right Side**

## SETTING UP FLOAT MODULE AT DEALER

- On the **RIGHT** side of the auger, install flighting (A) using five bolts and nuts at locations (B). Install the longer bolt and nut at location (C) to secure magnetic reverser shield (D) to the drum and flighting.
- Torque all nuts and bolts at locations (B) and (C) attaching the flighting and the magnetic reverser shield to 47 Nm (35 lbf·ft) to eliminate deflection on the flighting, then retorque them to 61 Nm (45 lbf·ft).

### NOTE:

Flighting performs best when no gaps are present. If desired, use silicone sealant to fill the gaps.

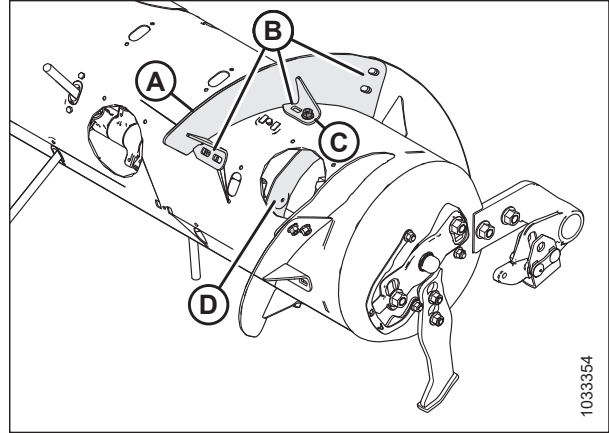

Figure 4.22: Medium Configuration – Right Side

- On the **LEFT** side of the auger, remove two flighting slot plugs from locations (A).

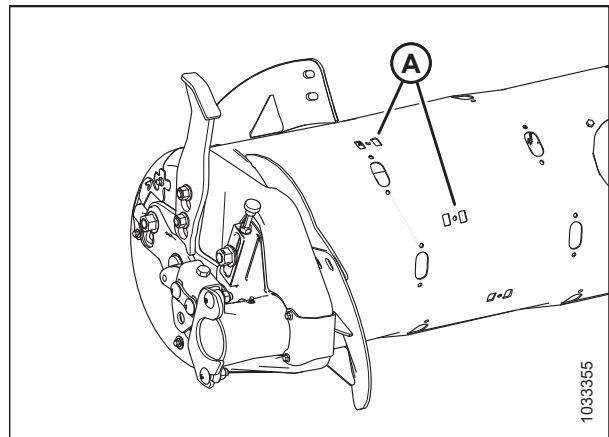

Figure 4.23: Wide Configuration – Left Side

- On the **LEFT** side of the auger, install bolt-on flighting (A), and secure with six carriage head bolts and six nuts at locations (B).

### IMPORTANT:

Bolt heads must be installed on the inside of the auger to prevent damaging internal components.

- Torque all nuts and bolts at locations (B) to 47 Nm (35 lbf·ft) to eliminate deflection on flighting, then torque them to 61 Nm (45 lbf·ft).

### NOTE:

Flighting performs best when no gaps are present. If desired, use silicone sealant to fill the gaps.

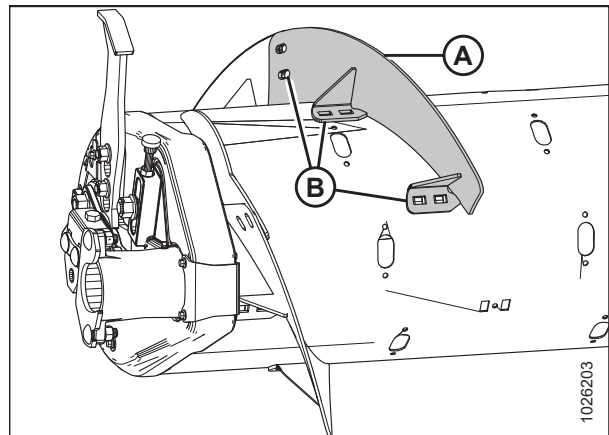

Figure 4.24: Medium Configuration – Left Side

- Remove extra auger fingers. A total of 22 fingers are recommended for this configuration. For instructions, refer to [4.2.12 Removing Feed Auger Fingers, page 77](#).

### 4.2.3 Converting from Medium Configuration or Wide Configuration to Narrow Configuration

Two flighting kits (MD #287032 or B6400<sup>1</sup>) are required to convert to this configuration. Extra hardware is included in these kits. Be sure to use the correct hardware in the correct location to prevent damage and to maximize performance.

Medium, Wide, and Narrow auger configurations are shown at right. When converting from Medium or Wide configuration to Narrow configuration, you will need to replace existing flightings (A) with flightings (B).

**NOTE:**

Flighting performs best when no gaps are present. If desired, use silicone sealant to fill the gaps.

**NOTE:**

All illustrations show the feed auger separated from the float module for clarity. The procedure can be performed with the feed auger installed in the float module.

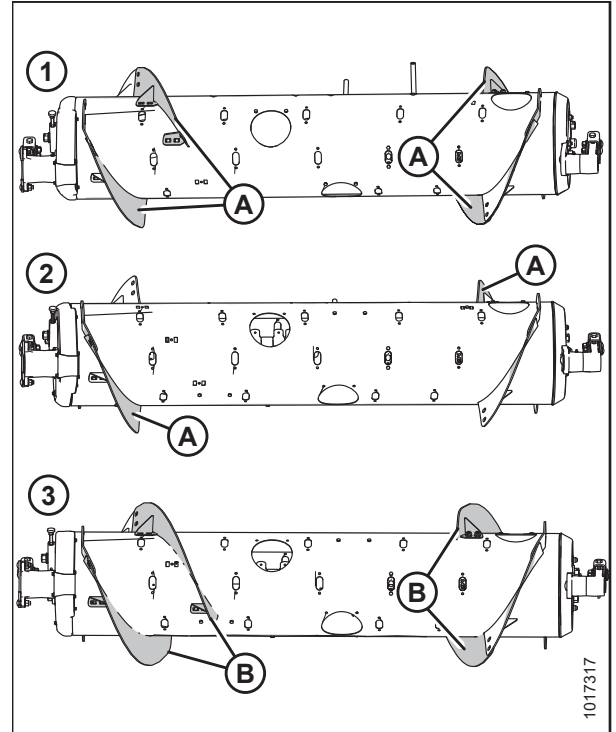

**Figure 4.25: Auger Configurations – Rear View**

- 1 - Medium Configuration
- 2 - Wide Configuration
- 3 - Narrow Configuration

1. To improve access and ease installation, remove float module from combine. For instructions, refer to the header operator’s manual or technical manual.
2. Remove bolts (A) and both access covers (B) (one shown) from the right side of the auger. Retain for reassembly. Repeat step for the left side of the auger.

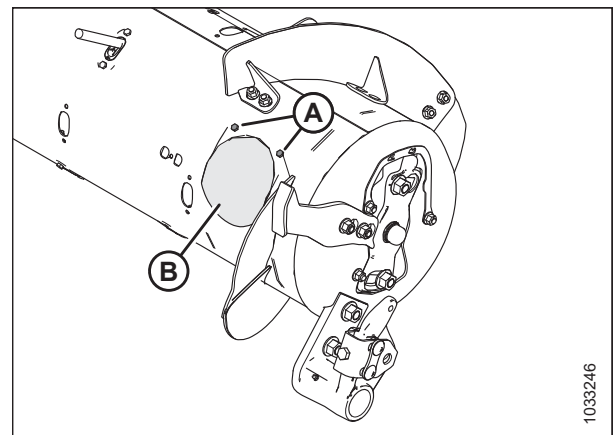

**Figure 4.26: Medium Configuration – Right Side**

1. MD #287032 is available only through MacDon Parts. B6400 is available only through Whole Goods. Both kits contain wear-resistant flightings.

## SETTING UP FLOAT MODULE AT DEALER

### 3. Converting from Medium configuration:

On the **RIGHT** side of the auger, note the position of auger pivot (A) to distinguish between flightings (F) and (H).

#### NOTE:

On the **RIGHT** side of the auger, a bolt and nut at locations (B) and (C) attach magnetic reverser shield (D) to the drum and flightings. Keep bolts and nuts from locations (B) and (C) separate from the rest of the retained hardware because these bolts are slightly longer. Whenever modifying or servicing the auger, keep at least one side of the reverser shield attached to the drum if possible. A completely detached reverser shield is more difficult to install because the shield is magnetically attracted to the drum.

Remove bolts and nuts from locations (B) and (E) from flighting (F). Remove flighting.

Resecure magnetic shield (D) using bolt and nut at location (B).

Remove bolt and nut from locations (C) and (G). Remove flighting (H).

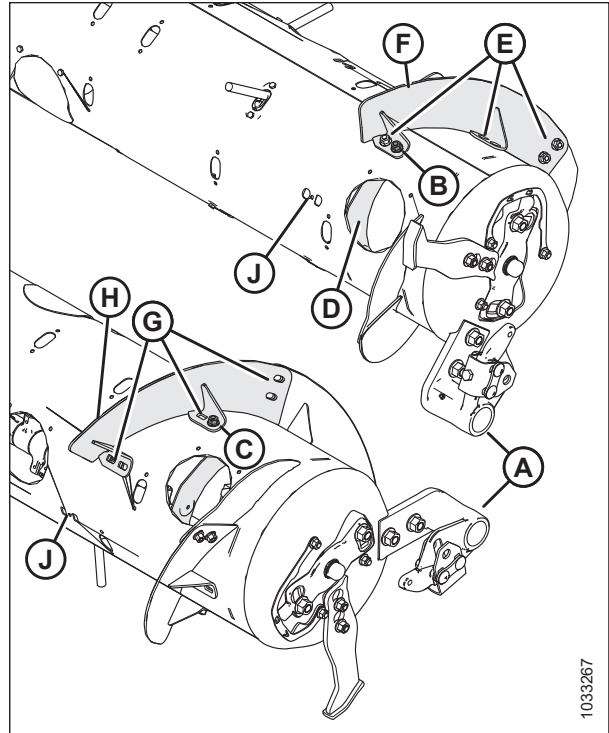

Figure 4.27: Medium Configuration – Right Side

### 4. Converting from Medium configuration: Remove flighting slot plugs from locations (J) close to the ends of the flightings.

### 5. Converting from Medium configuration: On the **LEFT** side of the auger, remove bolts and nuts from locations (A) that attach flightings (B) to the left side of the auger. Remove flightings.

### 6. Converting from Medium configuration: Remove flighting slot plugs from locations (C) close to the ends of the flightings.

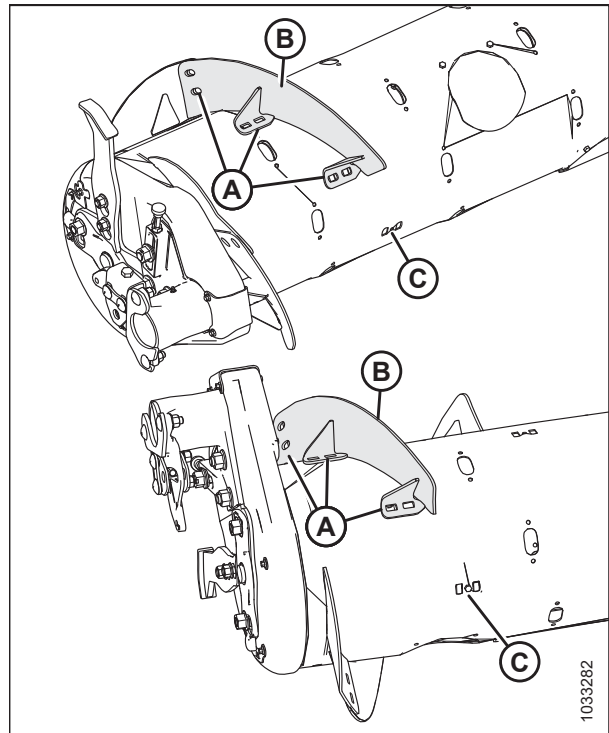

Figure 4.28: Medium Configuration – Left Side

## SETTING UP FLOAT MODULE AT DEALER

### 7. Converting from Wide configuration:

#### NOTE:

On the **RIGHT** side of the auger, a bolt and nut at locations (A) and (E) attach magnetic reverser shield (D) to the drum and flightings. Keep bolts and nuts from locations (A) and (E) separate from the rest of the retained hardware because these bolts are slightly longer. Whenever modifying or servicing the auger, keep at least one side of the reverser shield attached to the drum if possible. A completely detached reverser shield is more difficult to install because the shield is magnetically attracted to the drum.

Remove bolts and nuts from locations (A) and (B) from flighting (C). Remove flighting. Resecure magnetic shield (D) using bolt and nut at location (A).

Remove bolt and nut from location (E).

### 8. Converting from Wide configuration: Remove flighting slot plugs from locations (F) from the right side of the auger.

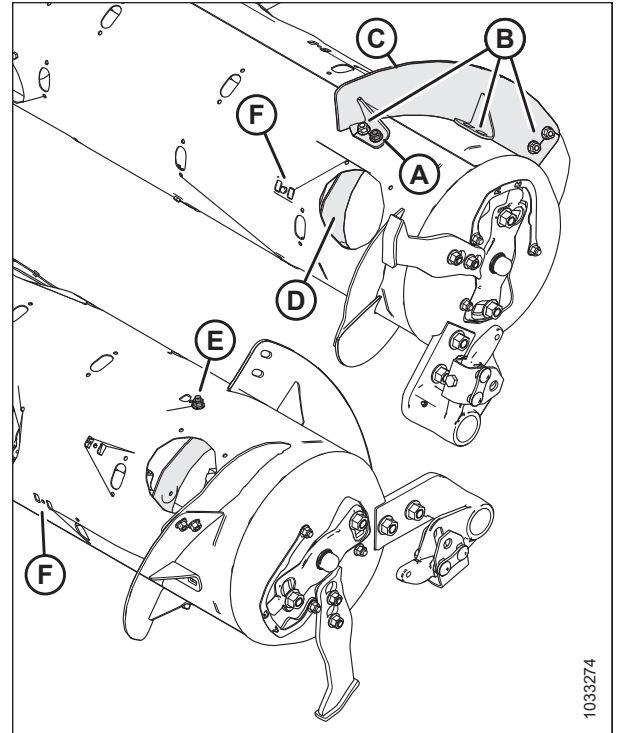

Figure 4.29: Wide Configuration – Right Side

### 9. Converting from Wide configuration: Remove bolts and nuts from locations (A) that attach flighting (B) to the left side of the auger. Remove flighting.

### 10. Converting from Wide configuration: Remove flighting slot plugs from locations (C) close to the ends of the flightings.

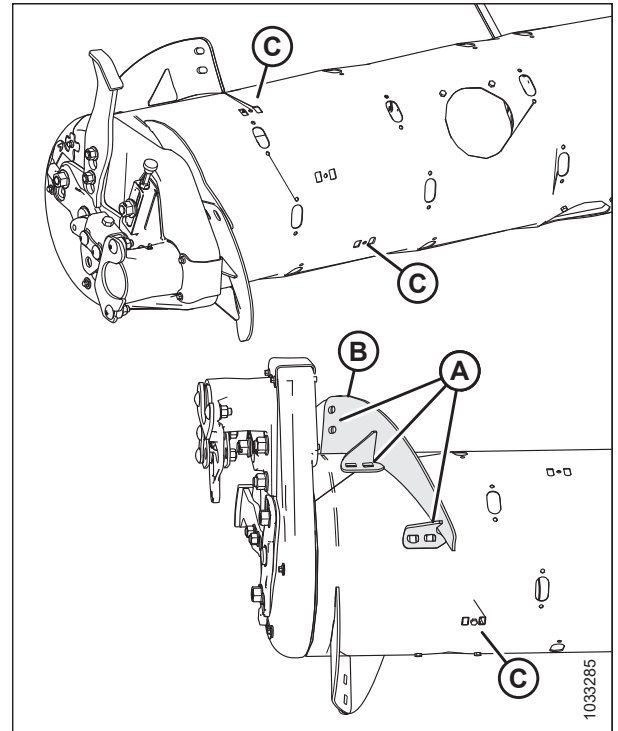

Figure 4.30: Wide Configuration – Left Side

## SETTING UP FLOAT MODULE AT DEALER

11. On the **RIGHT** side of the auger, install flighting (A) with newly drilled holes using bolts and nuts at locations (B). Install longer bolt and nut at location (C) to secure magnetic reverser shield (D) and flighting to the drum.

**NOTE:**

Bolt and nut at location (E) secure the other end of the reverser shield.

**IMPORTANT:**

Bolt heads must be installed on the inside of the auger to prevent damaging internal components.

12. **Converting from Medium configuration:** Install flighting slot plug at location (F) and secure with M6 bolts and tee nuts. Torque to 9 Nm (80 lbf-in).

**NOTE:**

If plug bolts are **NOT** new, coat bolts with medium-strength threadlocker (Loctite® 243 or equivalent) prior to installation.

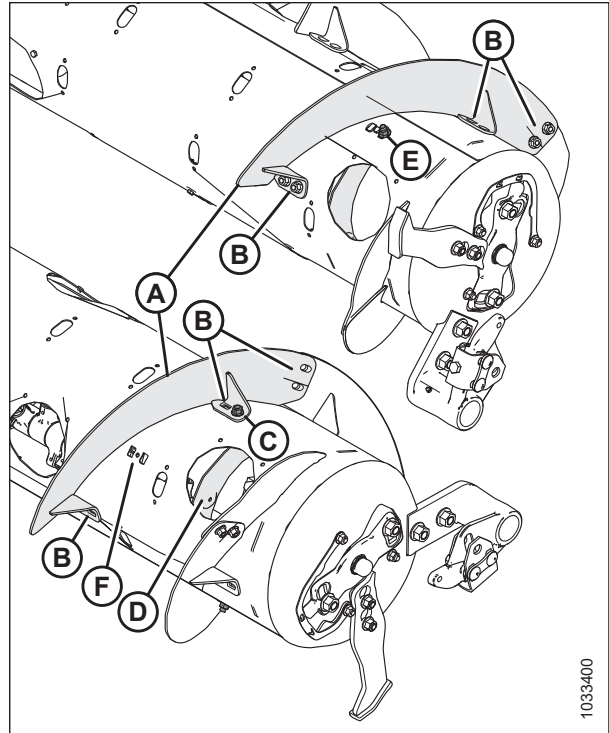

Figure 4.31: Right Side of Auger

13. On the **LEFT** side of the auger, install two bolt-on flightings (A) on the left side as shown, and secure each flighting with six carriage head bolts (MD #136178) and nuts (MD #135799) at locations (B).

**IMPORTANT:**

Bolt heads must be installed on the inside of the auger to prevent damaging internal components.

14. Install flighting slot plugs at the locations listed below and secure with M6 bolts and tee nuts. Torque to 9 Nm (80 lbf-in).

- **Converting from Medium configuration:** Install plugs at locations (C) and (D).
- **Converting from Wide configuration:** Install plug at location (D). There should already be a plug at location (C).

**NOTE:**

If plug bolts are **NOT** new, coat bolts with medium-strength threadlocker (Loctite® 243 or equivalent) prior to installation.

15. Torque all nuts and bolts attaching the flighting and the magnetic reverser shield to 47 Nm (35 lbf-ft) to eliminate deflection on the flighting, then retorque them to 61 Nm (45 lbf-ft).

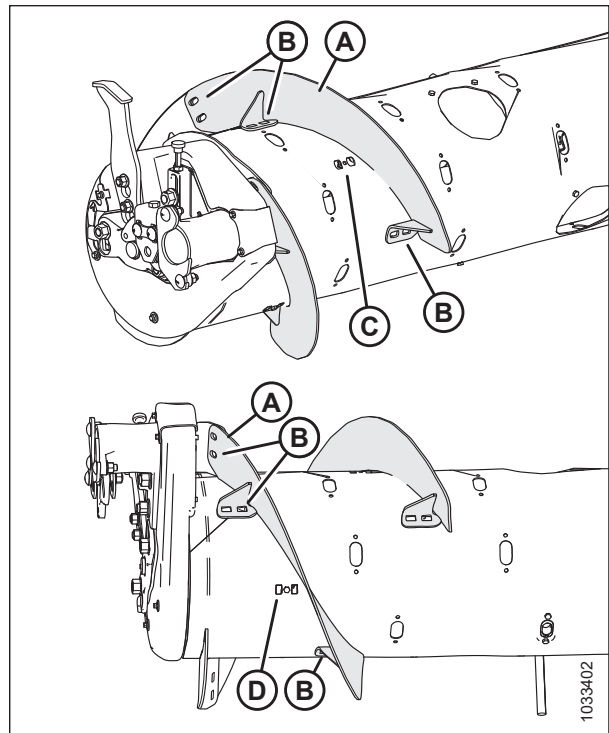

Figure 4.32: Narrow Configuration – Left Side of Auger

**NOTE:**

Flighting performs best when no gaps are present. If desired, use silicone sealant to fill the gaps.

- Remove extra auger fingers. A total of 18 fingers is recommended for this configuration. For instructions, refer to [4.2.12 Removing Feed Auger Fingers, page 77](#).

### 4.2.4 Converting from Ultra Narrow Configuration to Narrow Configuration

The Ultra Narrow and Narrow auger configurations are shown at right. Existing flightings (A) are removed from the auger when converting to the Narrow configuration.

**NOTE:**

All illustrations show the feed auger separated from the float module for clarity. The procedure can be performed with the feed auger installed in the float module.

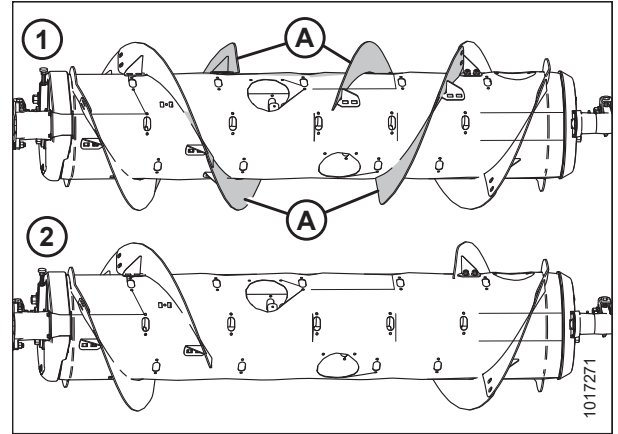

**Figure 4.33: Auger Configurations – Rear View**

1 - Ultra Narrow Configuration      2 - Narrow Configuration

- Improve access and ease installation by removing the float module from the combine. For instructions, refer to the header operator's manual or technical manual.
- Remove bolts (A) and access cover (B). Retain for reassembly.
- Remove hardware from locations (C), and remove bolt-on flighting (D) from feed auger.
- Repeat procedure for the remaining three inboard flightings.
- Install additional auger fingers. A total of 18 fingers is recommended for this configuration. For instructions, refer to [4.2.11 Installing Feed Auger Fingers, page 75](#).

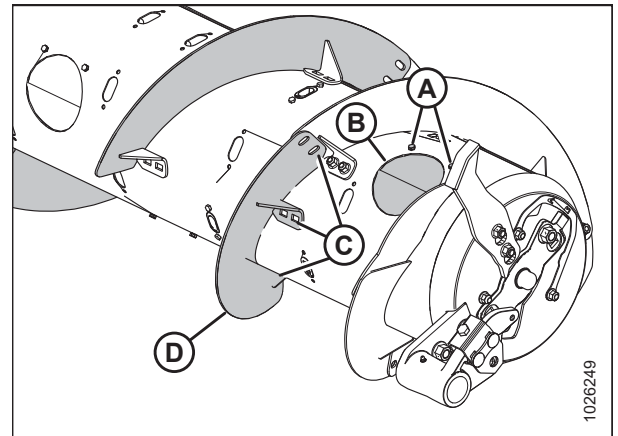

**Figure 4.34: Ultra Narrow Configuration – Right Side**

## 4.2.5 Converting from Medium Configuration to Wide Configuration or Ultra Wide Configuration

When converting from Medium configuration to Wide configuration, you will need to remove existing flightings (A) from the auger and add auger fingers. When converting from Medium configuration to Ultra Wide configuration, you will need to remove all existing bolt-on flightings (A) from the auger and add auger fingers.

Four flighting plugs (MD #213084), M6 hex head bolts (MD #252703), and M6 tee nuts (MD #197263) are needed to cover exposed flighting mounting holes after the flightings are removed.

**NOTE:**

All illustrations show the feed auger separated from the float module for clarity. The procedure can be performed with the feed auger installed in the float module.

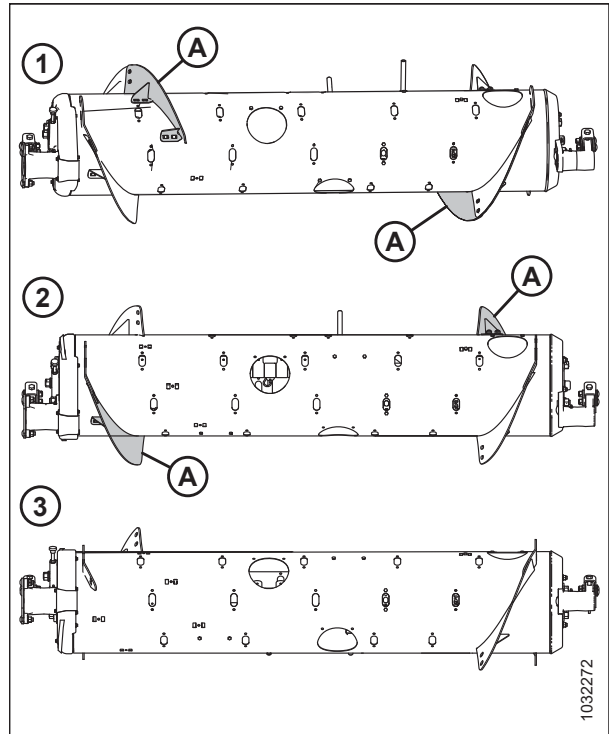

**Figure 4.35: Auger Configurations – Rear View**

1 - Medium Configuration	2 - Wide Configuration	3 - Ultra Wide Configuration
--------------------------	------------------------	------------------------------

1. Improve access and ease installation by removing the float module from the combine. For instructions, refer to the header operator’s manual or technical manual.

**NOTE:**

Some parts have been removed from the illustrations for clarity.

2. Remove bolts (A) and both access covers (B) (one shown) from the right side of the auger. Retain for reassembly. Repeat step for the left side of the auger.

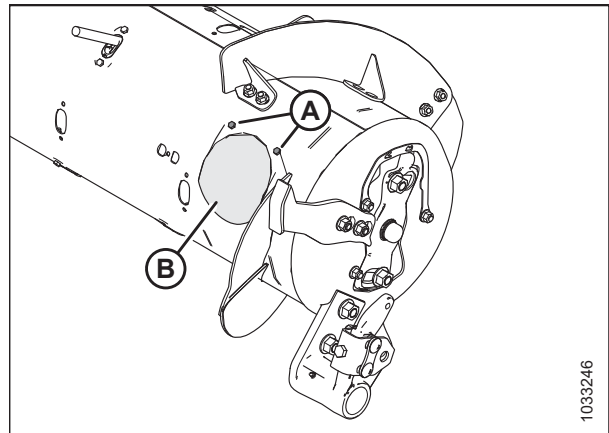

**Figure 4.36: Medium Configuration – Right Side**



## SETTING UP FLOAT MODULE AT DEALER

To convert from Medium configuration to Wide configuration, follow these steps:

### 3. Converting to Wide Configuration:

On the **RIGHT** side of the auger, note the position of auger pivot (A) to distinguish between flightings (D) and (H).

#### NOTE:

On the **RIGHT** side of the auger, a bolt and nut at locations (B) and (F) attach magnetic reverser shield (E) to the drum and flightings. Keep bolts and nuts from locations (B) and (F) separate from the rest of the retained hardware because these bolts are slightly longer. Whenever modifying or servicing the auger, keep at least one side of the reverser shield attached to the drum if possible. A completely detached reverser shield is more difficult to install because the shield is magnetically attracted to the drum.

Remove bolts and nuts from locations (B) and (C) from flighting (D). Remove flighting (D).

Resecure magnetic shield (E) using bolt and nut at location (B).

Leave flighting (H) installed.

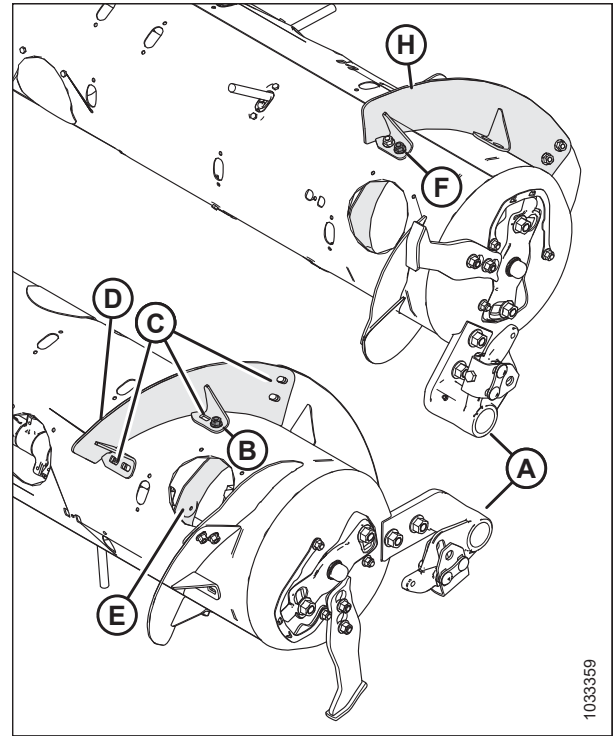

Figure 4.37: Medium Configuration – Right Side

### 4. Converting to Wide configuration:

On the **RIGHT** side of the auger, torque nut and bolt at location (A) that attach magnetic reverser shield (B) to the drum to 61 Nm (45 lbf-ft).

Install flighting slot plug at location (C) and secure with M6 bolts and tee nuts. Torque to 9 Nm (80 lbf-in).

#### NOTE:

If plug bolts are **NOT** new, coat bolts with medium-strength threadlocker (Loctite® 243 or equivalent) prior to installation.

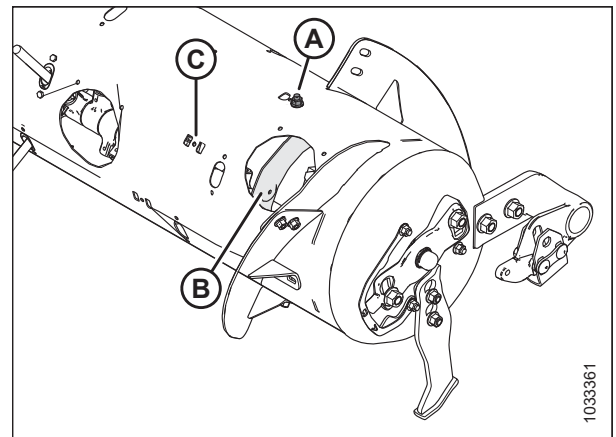

Figure 4.38: Wide Configuration – Right Side

## SETTING UP FLOAT MODULE AT DEALER

5. On the **LEFT** side of the auger, note the position of auger pivot (A) to distinguish between flightings (C) and (D). Remove six bolts and nuts from locations (B). Remove flighting (C). Leave flighting (D) installed.

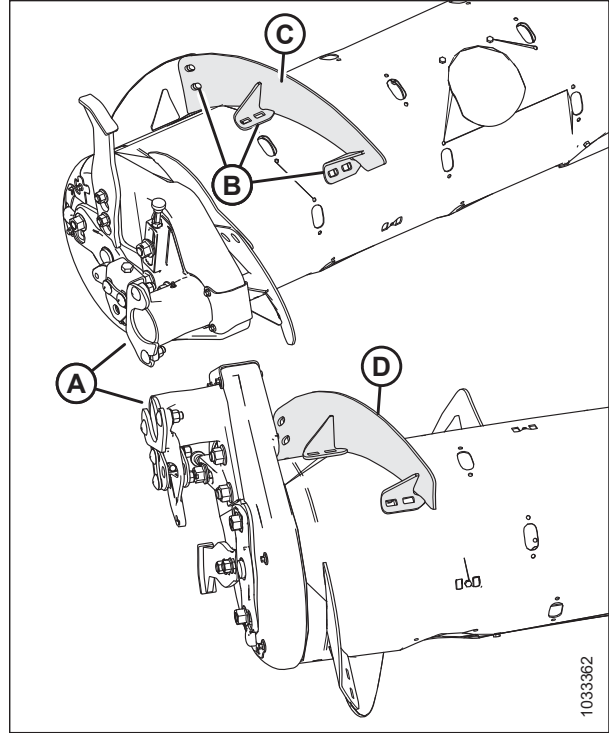

Figure 4.39: Medium Configuration – Left Side

6. On the **LEFT** side of the auger, install flighting slot plugs at locations (A) and secure with M6 bolts and tee nuts. Torque to 9 Nm (80 lbf-in).

**NOTE:**

If plug bolts are **NOT** new, coat bolts with medium-strength threadlocker (Loctite® 243 or equivalent) prior to installation.

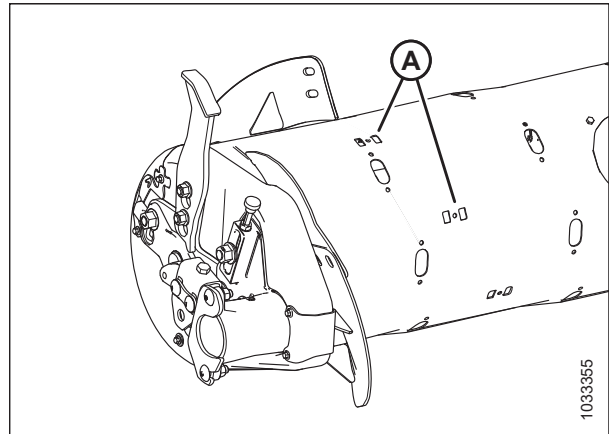

Figure 4.40: Wide Configuration – Left Side

7. Install additional fingers. A total of 30 fingers are recommended for the Wide configuration. For instructions, refer to [4.2.11 Installing Feed Auger Fingers, page 75](#).

## SETTING UP FLOAT MODULE AT DEALER

To convert from Medium configuration to Ultra Wide configuration, follow these steps:

### 8. Converting to Ultra Wide configuration:

On the **RIGHT** side of the auger, note the position of auger pivot (A) to distinguish between flightings (D) and (H).

#### NOTE:

On the **RIGHT** side of the auger, a bolt and nut at locations (B) and (F) attach magnetic reverser shield (E) to the drum and flightings. Keep bolts and nuts from locations (B) and (F) separate from the rest of the retained hardware because these bolts are slightly longer. Whenever modifying or servicing the auger, keep at least one side of the reverser shield attached to the drum if possible. A completely detached reverser shield is more difficult to install because the shield is magnetically attracted to the drum.

Remove bolts and nuts from locations (B) and (C) from flighting (D). Remove flighting (D).

Resecure magnetic shield (E) using bolt and nut at location (B).

Remove bolt and nut from locations (F) and (G). Remove flighting (H).

Resecure magnetic shield using bolt and nut at location (F).

### 9. Converting to Ultra Wide configuration:

On the **RIGHT** side of the auger, torque nuts and bolts at locations (A) that attach magnetic reverser shield (C) to 61 Nm (45 lbf-ft).

Install flighting slot plugs at locations (B) and secure with M6 bolts and tee nuts. Torque to 9 Nm (80 lbf-in).

#### NOTE:

If plug bolts are **NOT** new, coat bolts with medium-strength threadlocker (Loctite® 243 or equivalent) prior to installation.

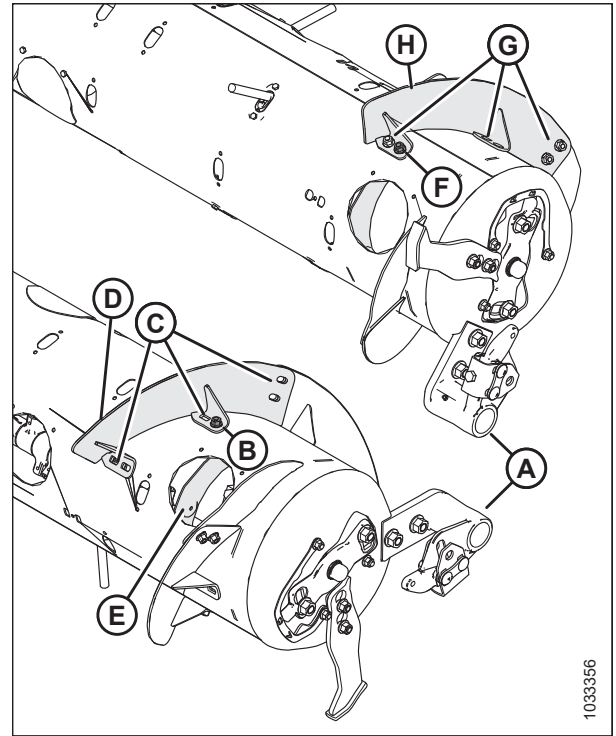

Figure 4.41: Medium Configuration – Right Side

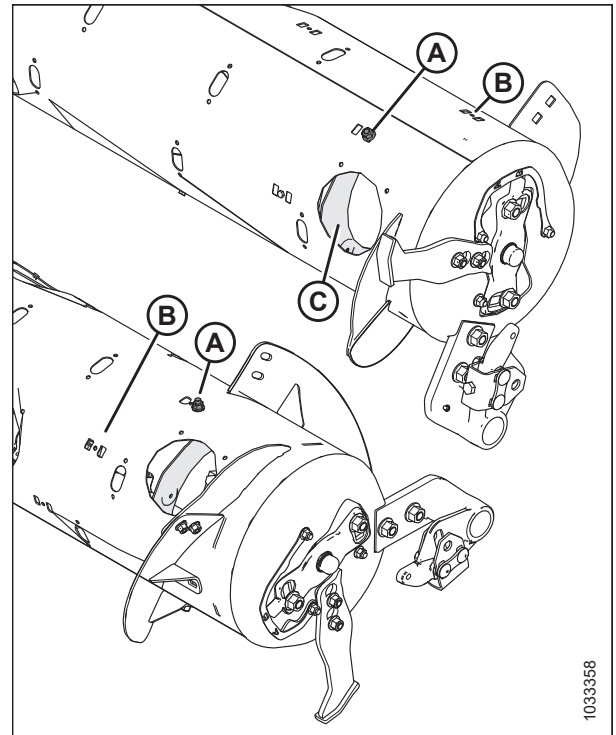

Figure 4.42: Ultra Wide Configuration – Right Side

## SETTING UP FLOAT MODULE AT DEALER

10. On the **LEFT** side of the auger, remove all bolts and nuts from locations (A). Remove flightings (B).

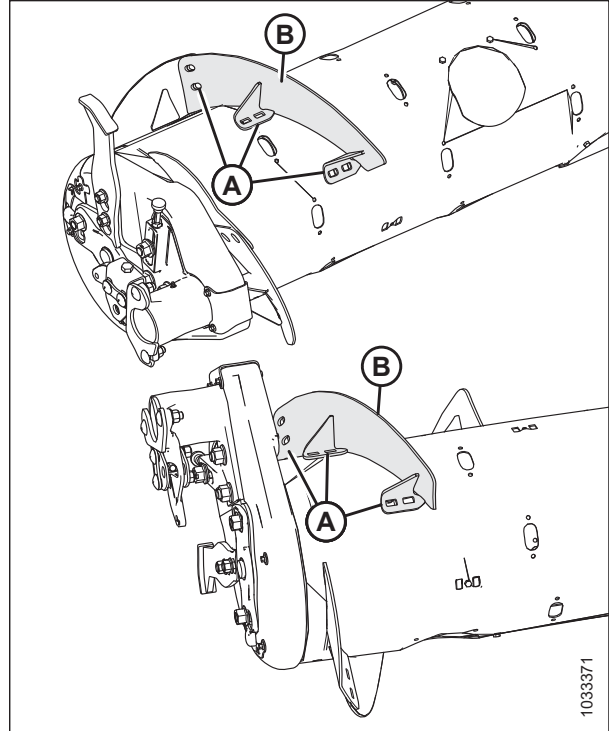

Figure 4.43: Medium Configuration – Left Side

11. On the **LEFT** side of the auger, install flighting slot plugs at locations (A) and secure with M6 bolts and tee nuts. Torque to 9 Nm (80 lbf-in).

**NOTE:**

If plug bolts are **NOT** new, coat bolts with medium-strength threadlocker (Loctite® 243 or equivalent) prior to installation.

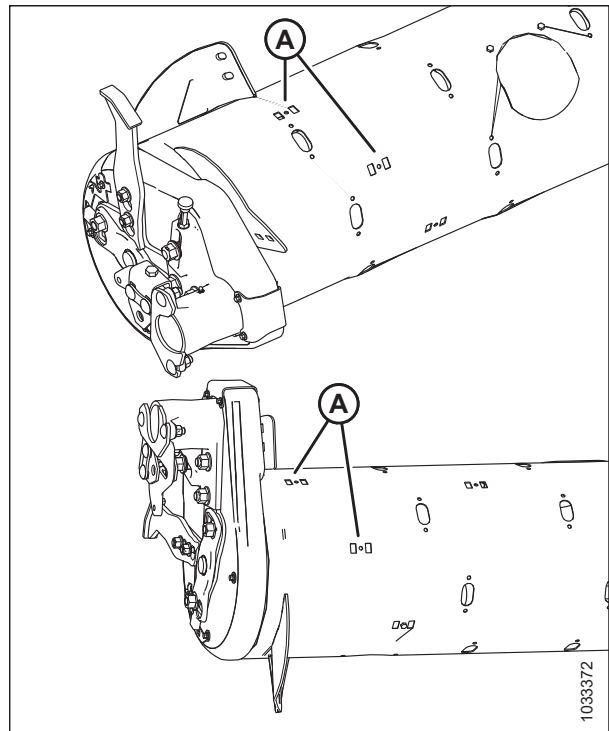

Figure 4.44: Ultra Wide Configuration – Left Side

12. Install additional fingers. A total of 30 fingers are recommended for the Wide configuration. For instructions, refer to [4.2.11 Installing Feed Auger Fingers, page 75](#).

### 4.2.6 Converting from Ultra Narrow or Narrow Configuration to Wide Configuration

One flighting kit (MD #287031) is required to convert to this configuration. Two flighting plugs (MD #213084), two M6 hex head bolts (MD #252703), and two M6 tee nuts (MD #197263) are recommended to close the flighting mounting locations. These parts can be ordered from a MacDon Dealer.

The Narrow, Ultra Narrow, and Wide auger configurations are shown at right. When converting from Narrow or Ultra Narrow configuration to Wide configuration, you will need to replace existing bolt-on flightings (A).

**NOTE:**

All illustrations show the feed auger separated from the float module for clarity. The procedure can be performed with the feed auger installed in the float module.

**NOTE:**

Some parts have been removed from the illustrations for clarity.

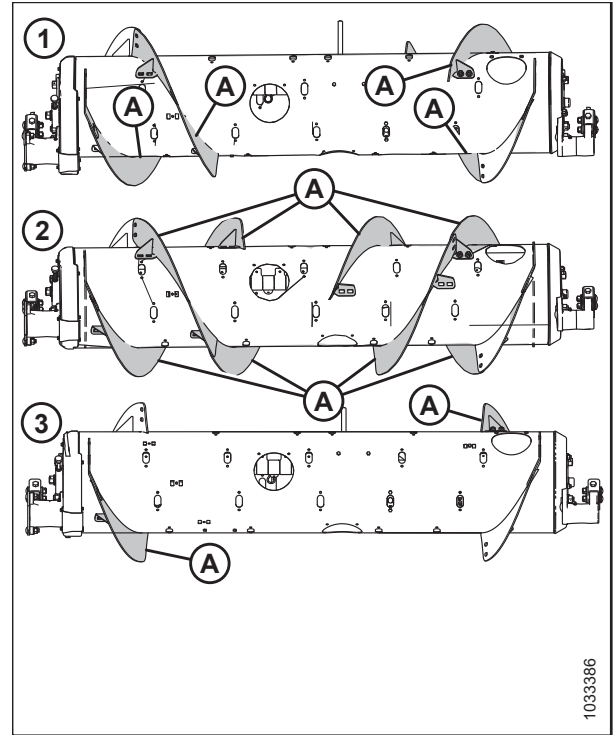

**Figure 4.45: Auger Configurations – Rear View**

- 1 - Narrow Configuration
- 2 - Ultra Narrow Configuration
- 3 - Wide Configuration

1. Improve access and ease installation by removing the float module from the combine. For instructions, refer to the header operator’s manual or technical manual.
2. Remove bolts (A) and access cover (B) from each side of the auger. Retain for reassembly.

**NOTE:**

If necessary, remove multiple access covers.

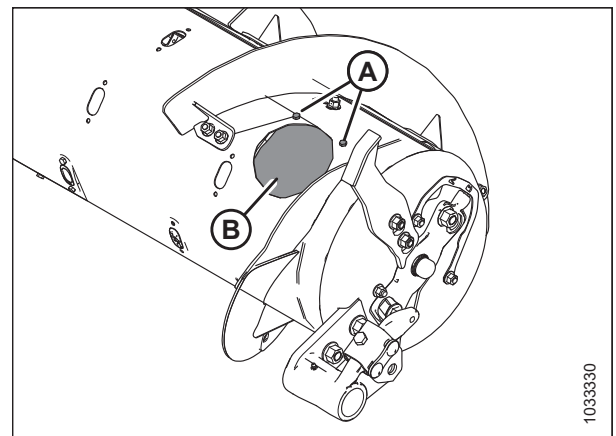

**Figure 4.46: Narrow Configuration – Right Side**

## SETTING UP FLOAT MODULE AT DEALER

3. **Converting from Ultra Narrow Configuration:** Remove hardware (A) from the four most inboard flightings (B).

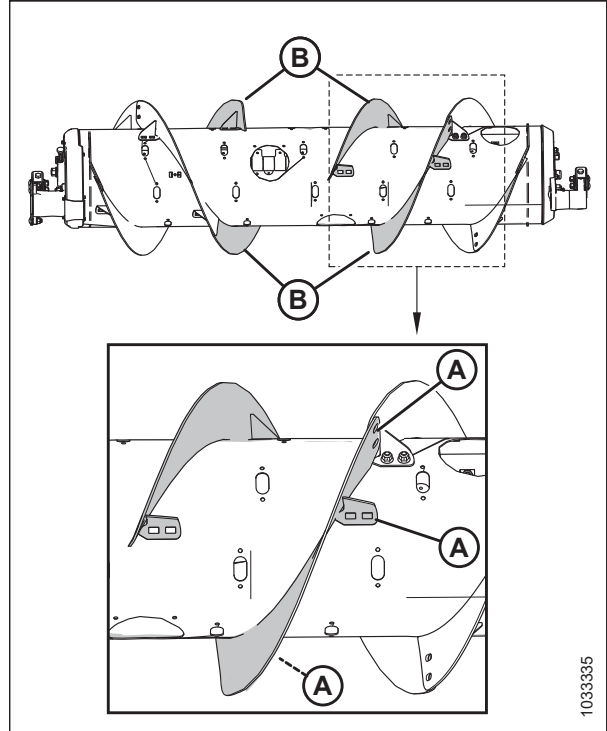

Figure 4.47: Ultra Narrow Configuration

4. On the **RIGHT** side of the auger, remove bolts and nuts from locations (C) and (B).

### NOTE:

On the **RIGHT** side of the auger, a bolt and nut at locations (C) and (E) attach magnetic reverser shield (D) to the drum and flightings. Keep bolts and nuts from locations (C) and (E) separate from the rest of the retained hardware because these bolts are slightly longer. Whenever modifying or servicing the auger, keep at least one side of the reverser shield attached to the drum if possible. A completely detached reverser shield is more difficult to install because the shield is magnetically attracted to the drum.

Remove flightings (A). Leave bolt and nut at location (E) installed.

Reinstall longer bolt and nut at location (C) to resecure magnetic shield (D).

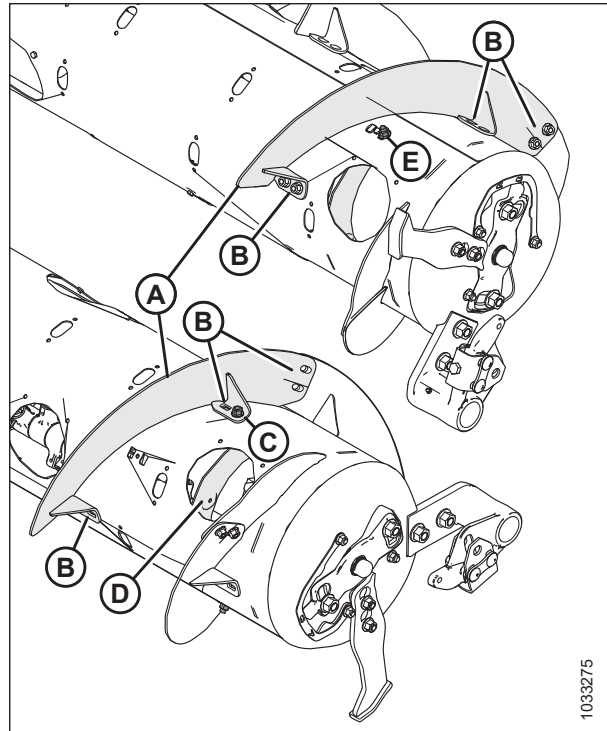

Figure 4.48: Narrow Configuration – Right Side of Auger

## SETTING UP FLOAT MODULE AT DEALER

5. Install flighting (C) using bolts and nuts at locations (B).

Reinstall longer bolt and nut at location (A) to resecure magnetic shield (D) to the drum and flighting.

Torque nuts and bolts at locations (A), (B), and (E) to 47 Nm (35 lbf-ft) to eliminate deflection on the flighting, then retorque them to 61 Nm (45 lbf-ft).

### IMPORTANT:

Flighting bolt heads must be installed on the inside of the auger to prevent damaging internal components.

### NOTE:

Flighting performs best when no gaps are present. If desired, use silicone sealant to fill the gaps.

6. Install flighting slot plugs at locations (F) and secure with M6 bolts and tee nuts. Torque to 9 Nm (80 lbf-in).

### NOTE:

If plug bolts are **NOT** new, coat bolts with medium-strength threadlocker (Loctite® 243 or equivalent) prior to installation.

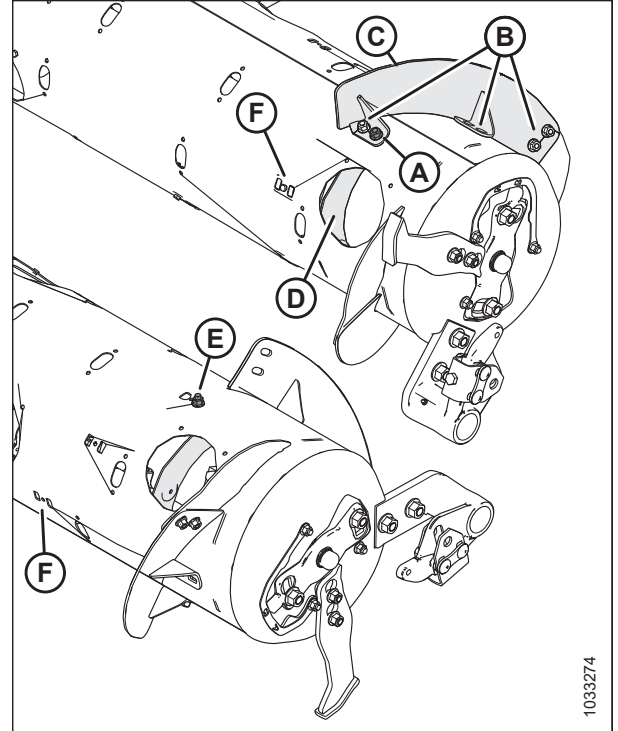

Figure 4.49: Wide Configuration – Right Side

7. On the **LEFT** side of the auger, remove bolts and nuts from locations (A). Remove two bolt-on flightings (B). Remove flighting slot plug from location (C).

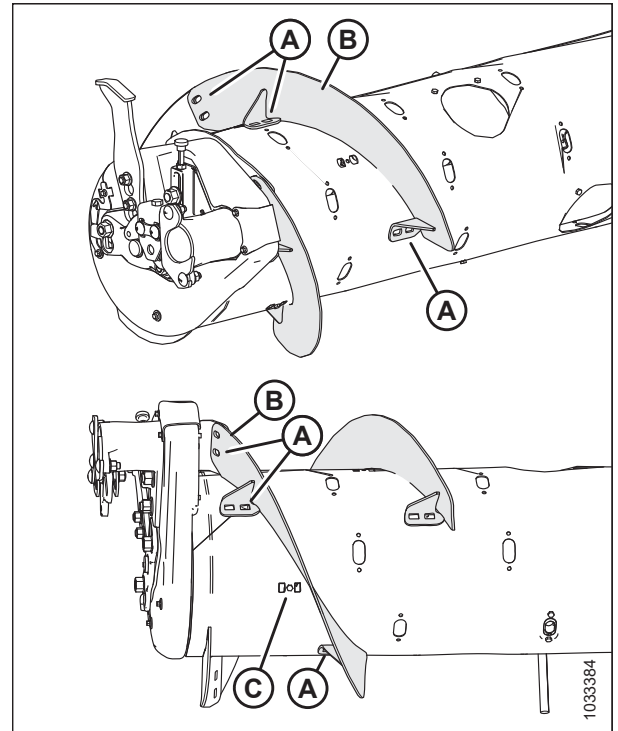

Figure 4.50: Left Side of Auger

## SETTING UP FLOAT MODULE AT DEALER

- On the **LEFT** side of the auger, install flighting (A) using bolts and nuts at locations (B). Torque all nuts and bolts attaching the flighting to 47 Nm (35 lbf·ft) to eliminate deflection on the flighting, then retorque them to 61 Nm (45 lbf·ft).

### IMPORTANT:

Flighting bolt heads must be installed on the inside of the auger to prevent damaging internal components.

### NOTE:

Flighting performs best when no gaps are present. If desired, use silicone sealant to fill the gaps.

- On the **LEFT** side of the auger, install flighting slot plugs at locations (C) and secure with M6 bolts and tee nuts. Torque to 9 Nm (80 lbf·in).

### NOTE:

If plug bolts are **NOT** new, coat bolts with medium-strength threadlocker (Loctite® 243 or equivalent) prior to installation.

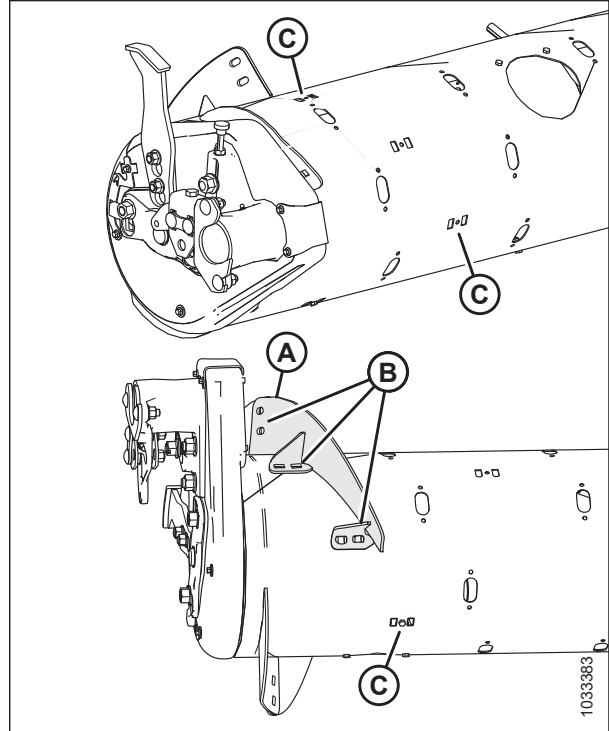

Figure 4.51: Wide Configuration – Left Side



## 4.2.7 Converting from Ultra Narrow or Narrow Configuration to Ultra Wide Configuration

Two M6 hex head bolts (MD #252703) and two M6 tee nuts (MD #197263) are required per flighting slot plug (MD #213084).

The Narrow, Ultra Narrow, and Ultra Wide auger configurations are shown at right. When converting from Narrow or Ultra Narrow configuration to Ultra Wide configuration, you will be removing all bolt-on flighting (A).

**NOTE:**

All illustrations show the feed auger separated from the float module for clarity. The procedure can be performed with the feed auger installed in the float module.

**NOTE:**

Some parts have been removed from the illustrations for clarity.

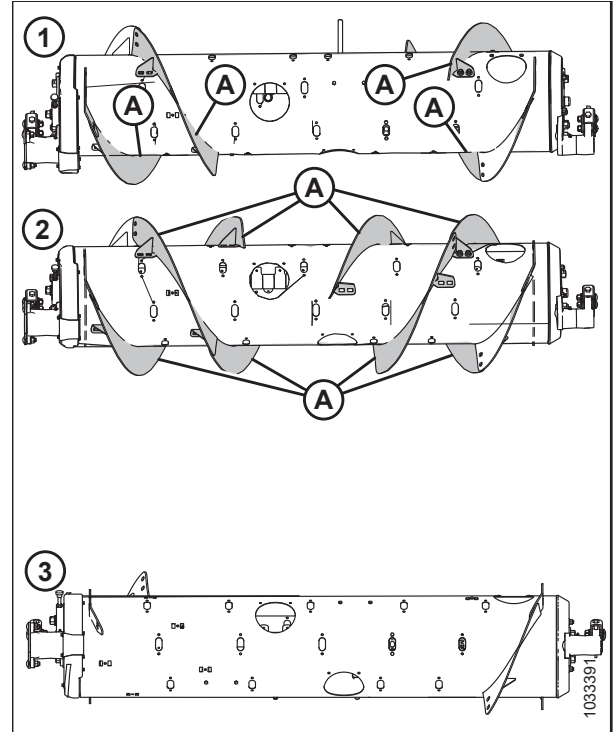

**Figure 4.52: Auger Configurations – Rear View**

- 1 - Narrow Configuration
- 2 - Ultra Narrow Configuration
- 3 - Ultra Wide Configuration

1. Improve access and ease installation by removing the float module from the combine. For instructions, refer to the header operator’s manual or technical manual.
2. Remove bolts (A) and access cover (B) from each side of the auger. Retain for reassembly.

**NOTE:**

If necessary, remove multiple access covers.

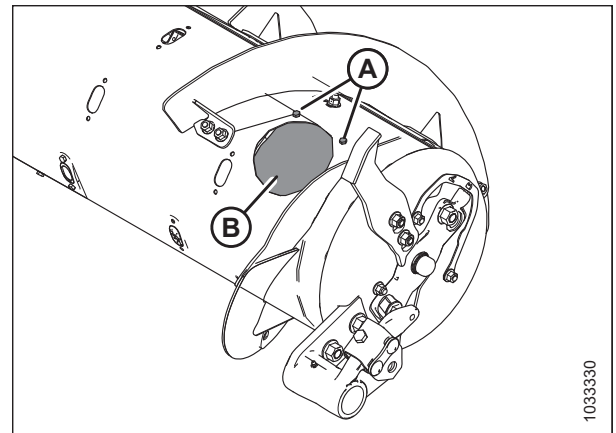

**Figure 4.53: Narrow Configuration – Right Side**

## SETTING UP FLOAT MODULE AT DEALER

3. **Converting from Ultra Narrow Configuration:** Remove hardware (A) from the four most inboard flightings (B).

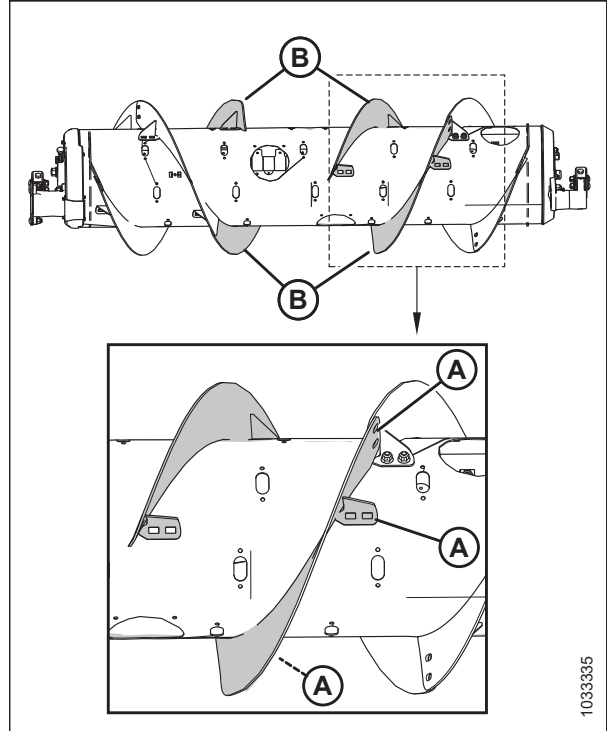

Figure 4.54: Ultra Narrow Configuration

4. On the **RIGHT** side of the auger, remove bolts and nuts from locations (C) and (B).

**NOTE:**

On the **RIGHT** side of the auger, a bolt and nut at locations (C) and (E) attach magnetic reverser shield (D) to the drum and flightings. Keep bolts and nuts from locations (C) and (E) separate from the rest of the retained hardware because these bolts are slightly longer. Whenever modifying or servicing the auger, keep at least one side of the reverser shield attached to the drum if possible. A completely detached reverser shield is more difficult to install because the shield is magnetically attracted to the drum.

Remove flightings (A). Leave bolt and nut at location (E) installed.

Reinstall longer bolt and nut at location (C) to resecure magnetic shield (D).

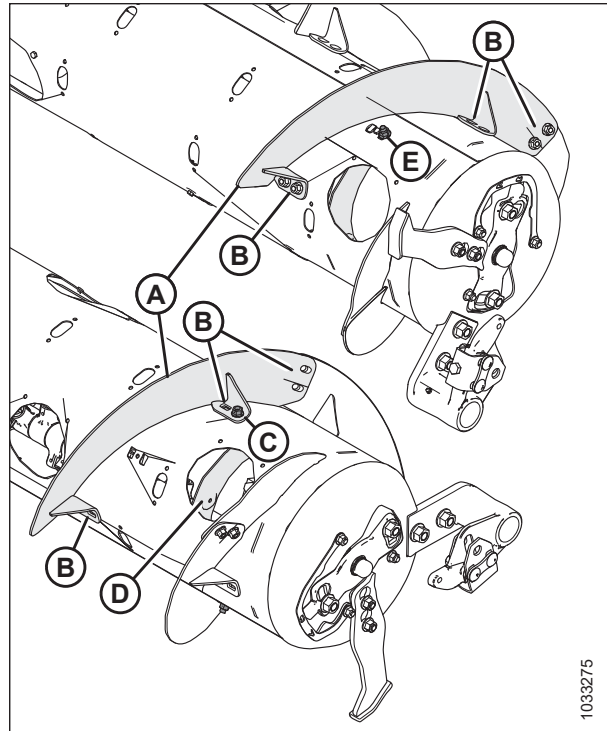

Figure 4.55: Narrow Configuration – Right Side of Auger

## SETTING UP FLOAT MODULE AT DEALER

5. On the **RIGHT** side of the auger, reinstall long bolt and nut at location (A) to attach magnetic reverser shield (B) to the drum. Torque bolts and nuts at locations (A) and (C) to 61 Nm (45 lbf-ft).

### IMPORTANT:

Bolt heads must be installed on the inside of the auger to prevent damaging internal components.

Install flighting slot plugs at locations (D) and secure with M6 bolts and tee nuts. Torque to 9 Nm (80 lbf-in).

### NOTE:

If plug bolts are **NOT** new, coat bolts with medium-strength threadlocker (Loctite® 243 or equivalent) prior to installation.

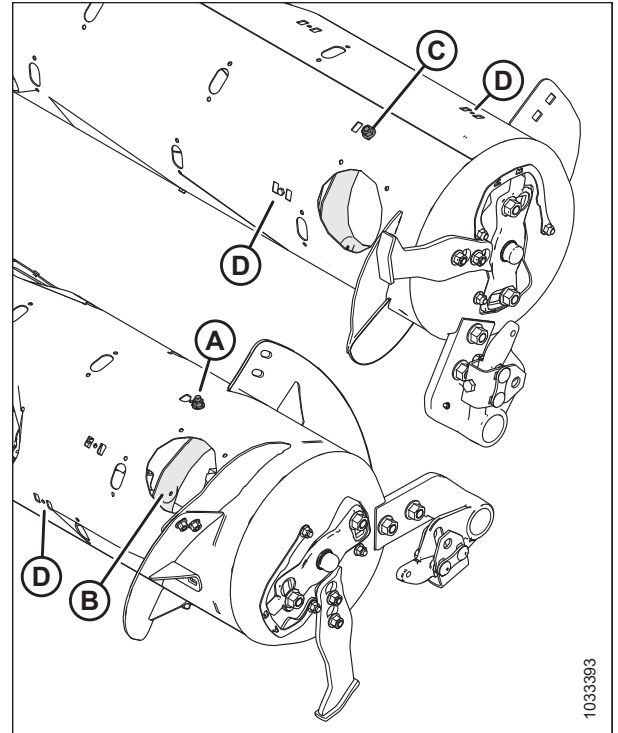

Figure 4.56: Ultra Wide Configuration – Right Side

6. On the **LEFT** side of the auger, remove bolts and nuts from locations (A). Remove two bolt-on flightings (B).

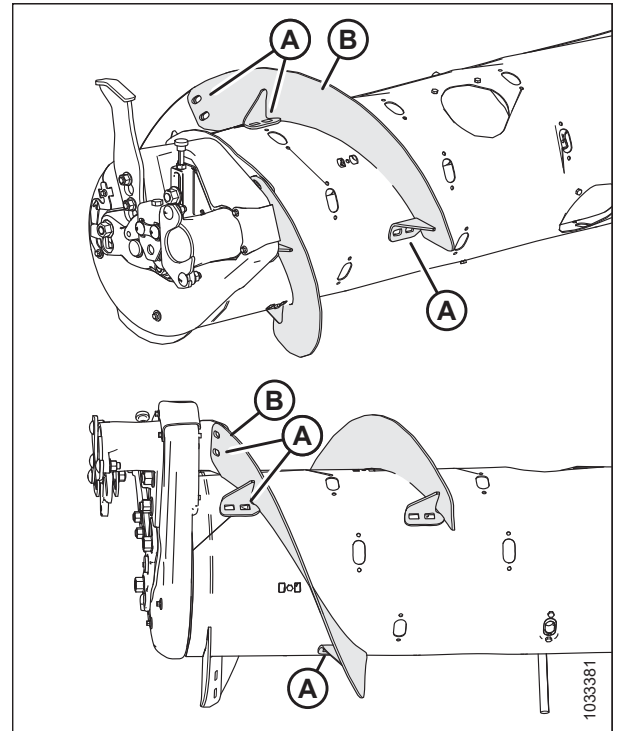

Figure 4.57: Narrow Configuration – Left Side of Auger

## SETTING UP FLOAT MODULE AT DEALER

7. On the **LEFT** side of the auger, install fighting slot plugs at locations (A) and secure with M6 bolts and tee nuts. Torque to 9 Nm (80 lbf-in).

**NOTE:**

If plug bolts are **NOT** new, coat bolts with medium-strength threadlocker (Loctite® 243 or equivalent) prior to installation.

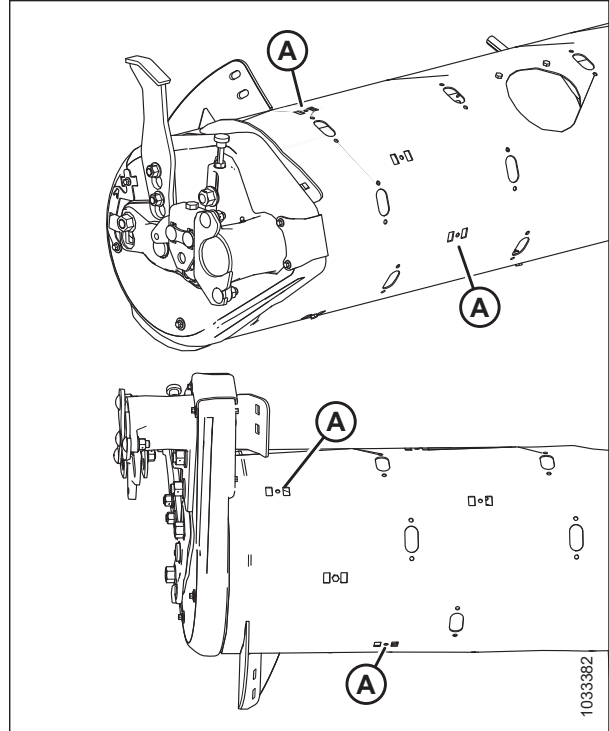

Figure 4.58: Ultra Wide Configuration – Right Side

### 4.2.8 Converting from Wide Configuration to Ultra Wide Configuration

Two M6 hex head bolts (MD #252703) and two M6 tee nuts (MD #197263) are required per fighting slot plug (MD #213084).

1. Improve access and ease installation by removing the float module from the combine. For instructions, refer to the header operator's manual or technical manual.
2. Remove two bolts (A) and access cover (B).

**NOTE:**

On the right side of the auger, remove the access cover closest to bolt-on fighting (C).

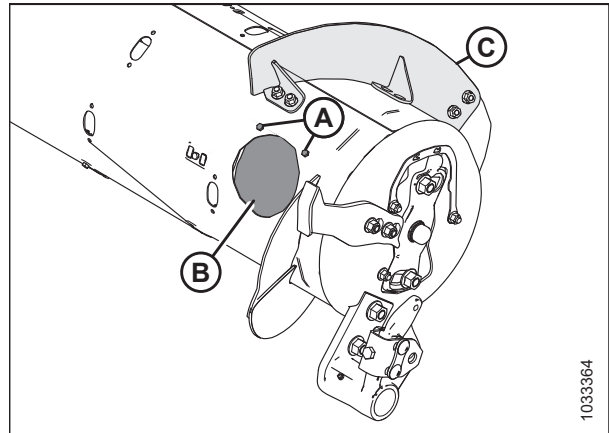

Figure 4.59: Wide Configuration – Right Side

## SETTING UP FLOAT MODULE AT DEALER

3. On the **RIGHT** side of the auger, remove bolts and nuts from locations (A) and (B) from flighting (C). Remove flighting (C).

**NOTE:**

On the **RIGHT** side of the auger, a bolt and nut at location (A) attaches one side of the magnetic reverser shield (D) to the drum and flightings. Keep bolt and nut from location (A) separate from the rest of the retained hardware because this bolts is slightly longer. Whenever modifying or servicing the auger, keep at least one side of the reverser shield attached to the drum if possible. A completely detached reverser shield is more difficult to install because the shield is magnetically attracted to the drum.

4. On the **RIGHT** side of the auger, resecure magnetic shield (B) using longer bolt and nut at location (A). Torque nut and bolt at location (A) to 61 Nm (45 lbf-ft).

Install flighting slot plug at location (C) and secure with M6 bolts and tee nuts. Torque to 9 Nm (80 lbf-in).

**NOTE:**

If plug bolts are **NOT** new, coat bolts with medium-strength threadlocker (Loctite® 243 or equivalent) prior to installation.

5. On the **LEFT** side of the auger, remove bolts and nuts from locations (A). Remove bolt-on flighting (B).

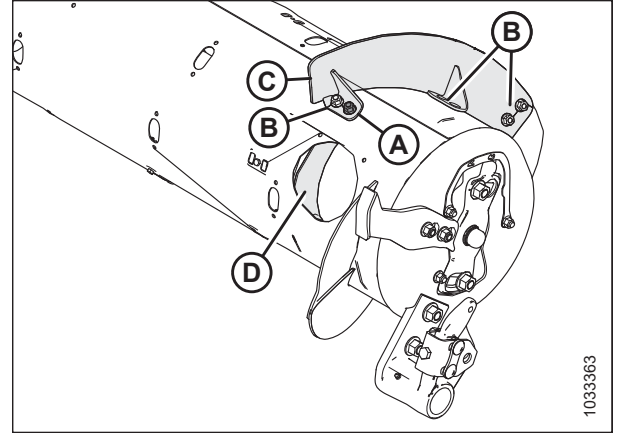

Figure 4.60: Wide Configuration – Right Side

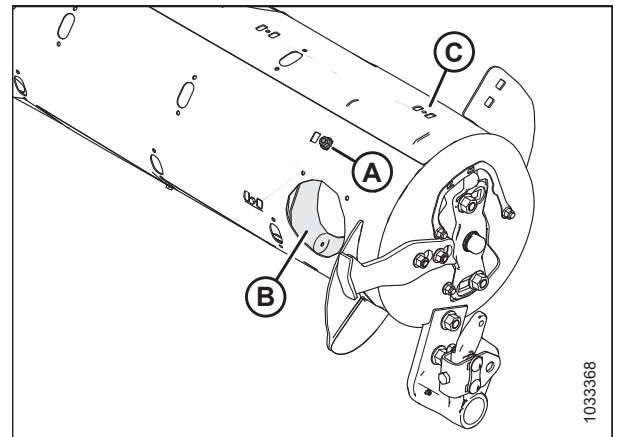

Figure 4.61: Wide Configuration – Right Side

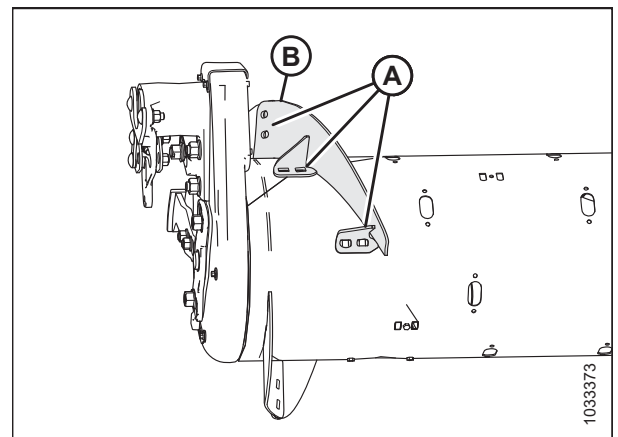

Figure 4.62: Wide Configuration – Left Side

## SETTING UP FLOAT MODULE AT DEALER

6. On the **LEFT** side of the auger, install flighting slot plugs at locations (A) and secure with M6 bolts and tee nuts. Torque to 9 Nm (80 lbf-in).

### NOTE:

If plug bolts are **NOT** new, coat bolts with medium-strength threadlocker (Loctite® 243 or equivalent) prior to installation.

7. Install additional auger fingers. A total of 30 fingers are recommended for this configuration. For instructions, refer to [4.2.11 Installing Feed Auger Fingers, page 75](#).

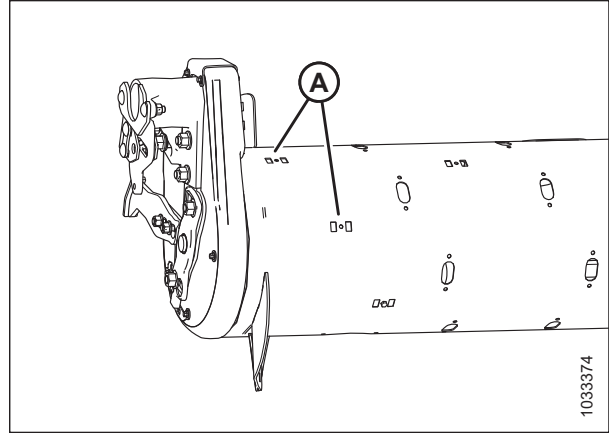

Figure 4.63: Ultra Wide Configuration – Left Side

### 4.2.9 Converting from Medium Configuration or Wide Configuration to Ultra Narrow Configuration

Four flighting kits (MD #287032 or B6400) and some hole-drilling are required to convert to Ultra Narrow configuration. Extra hardware is included in these kits. Be sure to use the correct hardware in the correct location to prevent damage and to maximize performance.

1. Improve access and ease installation by removing the float module from the combine. For instructions, refer to the header operator's manual or technical manual.
2. Remove bolts (A) and both access covers (B) (one shown) from the right side of the auger. Retain for reassembly. Repeat step for the left side of the auger.

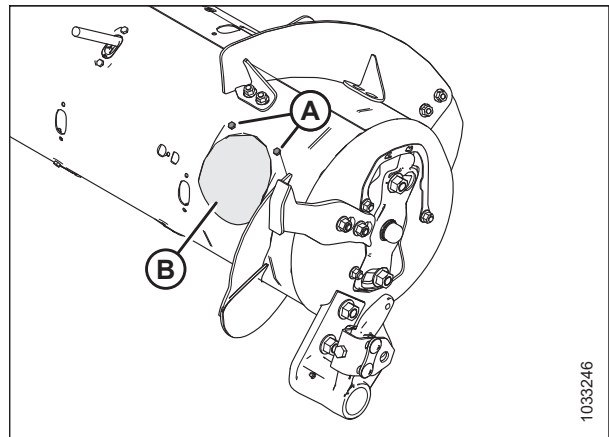

Figure 4.64: Medium Configuration – Right Side

## SETTING UP FLOAT MODULE AT DEALER

### 3. Converting from Medium configuration:

On the **RIGHT** side of the auger, note the position of auger pivot (A) to distinguish between flightings (F) and (H).

#### NOTE:

On the **RIGHT** side of the auger, a bolt and nut at locations (B) and (C) attach magnetic reverser shield (D) to the drum and flightings. Keep bolts and nuts from locations (B) and (C) separate from the rest of the retained hardware because these bolts are slightly longer. Whenever modifying or servicing the auger, keep at least one side of the reverser shield attached to the drum if possible. A completely detached reverser shield is more difficult to install because the shield is magnetically attracted to the drum.

Remove bolts and nuts from locations (B) and (E) from flighting (F). Remove flighting.

Resecure magnetic shield (D) using bolt and nut at location (B).

Remove bolt and nut from locations (C) and (G). Remove flighting (H).

4. **Converting from Medium configuration:** Remove flighting slot plugs from locations (J) close to the ends of the flightings.
5. **Converting from Medium configuration:** On the **LEFT** side of the auger, remove bolts and nuts from locations (A) that attach flightings (B) to the left side of the auger. Remove flightings.
6. **Converting from Medium configuration:** Remove flighting slot plugs from locations (C) close to the ends of the flightings.

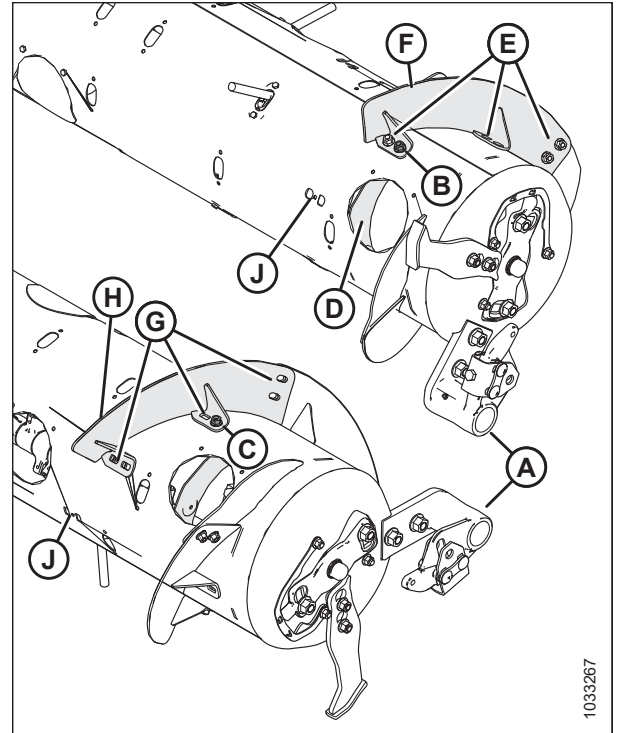

Figure 4.65: Medium Configuration – Right Side

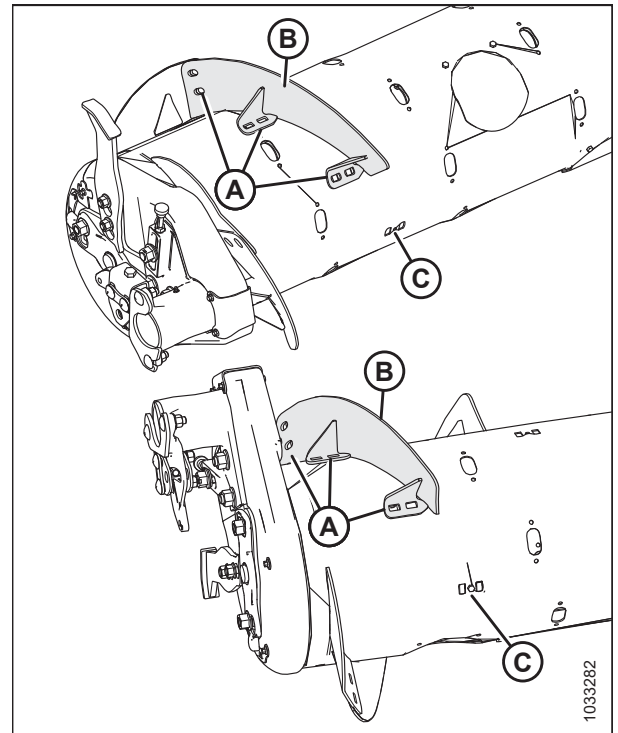

Figure 4.66: Medium Configuration – Left Side

## SETTING UP FLOAT MODULE AT DEALER

### 7. Converting from Wide configuration:

#### NOTE:

On the **RIGHT** side of the auger, a bolt and nut at locations (A) and (E) attach magnetic reverser shield (D) to the drum and flightings. Keep bolts and nuts from locations (A) and (E) separate from the rest of the retained hardware because these bolts are slightly longer. Whenever modifying or servicing the auger, keep at least one side of the reverser shield attached to the drum if possible. A completely detached reverser shield is more difficult to install because the shield is magnetically attracted to the drum.

Remove bolts and nuts from locations (A) and (B) from flighting (C). Remove flighting. Resecure magnetic shield (D) using bolt and nut at location (A).

Remove bolt and nut from location (E).

### 8. Converting from Wide configuration: Remove flighting slot plugs from locations (F) from the right side of the auger.

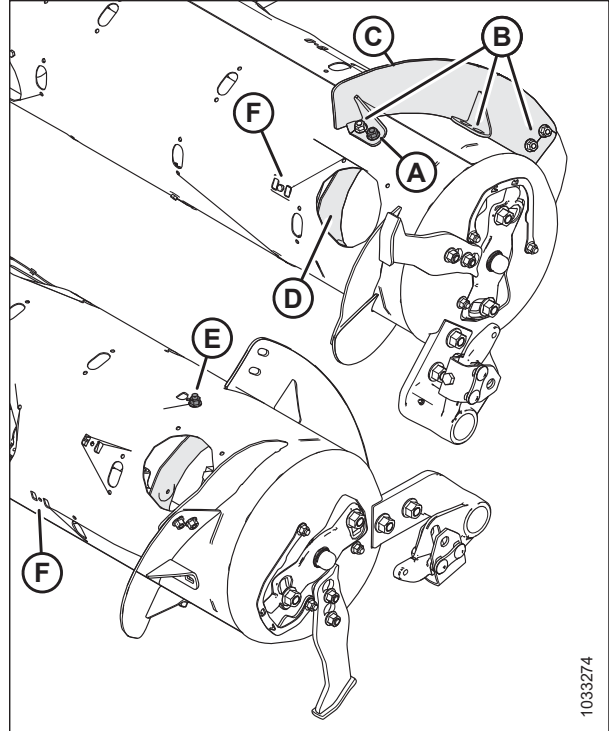

Figure 4.67: Wide Configuration – Right Side

### 9. Converting from Wide configuration: Remove bolts and nuts from locations (A) that attach flighting (B) to the left side of the auger. Remove flighting.

### 10. Converting from Wide configuration: Remove flighting slot plugs from locations (C) close to the ends of the flightings.

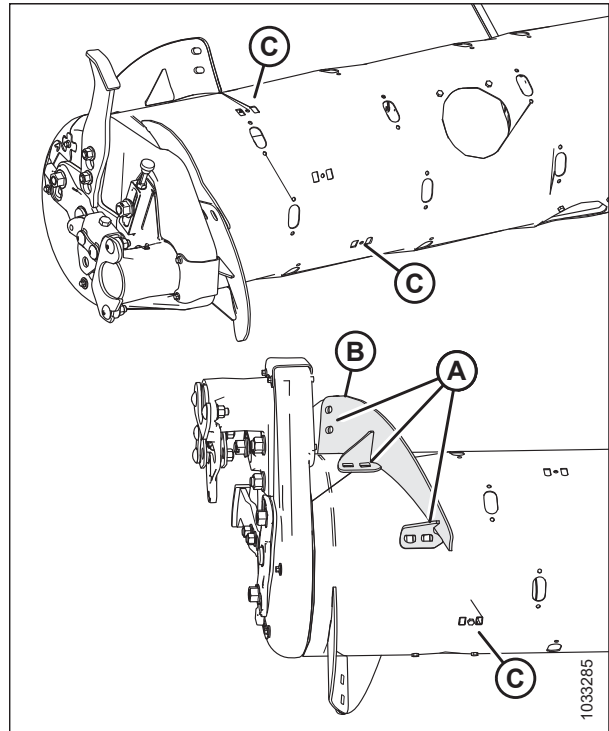

Figure 4.68: Wide Configuration – Left Side



## SETTING UP FLOAT MODULE AT DEALER

11. Position two bolt-on flightings (A) on the right side, as shown. Temporarily secure flightings with two carriage head bolts and nuts at locations (B). Temporarily secure flighting and magnetic reverser shield (D) with retained longer bolt and nut at location (C).

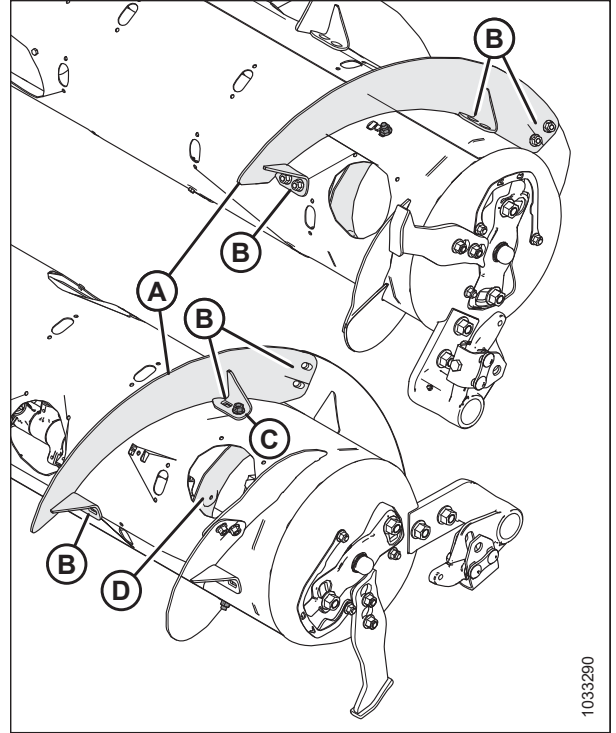

Figure 4.69: Right Side of Auger

12. Position another bolt-on flighting (A) outboard of the temporarily installed bolt-on flighting (B). Mark hole locations (C) of the bolt-on flighting onto the temporarily installed bolt-on flighting (B).
13. Remove temporarily installed bolt-on flighting (B) from the auger and drill two 11 mm (7/16 in.) holes at the marked locations.

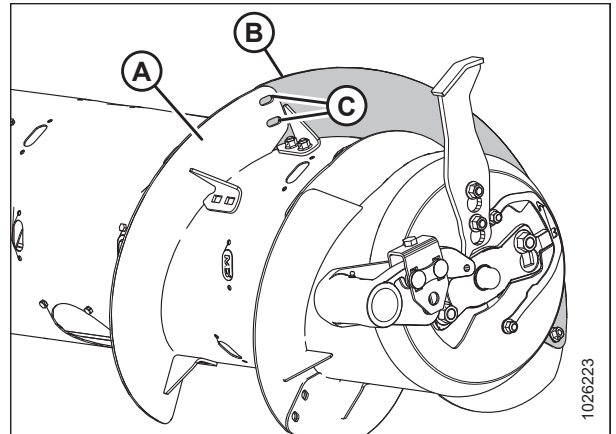

Figure 4.70: Right Side of Auger

## SETTING UP FLOAT MODULE AT DEALER

14. Install flighting (A) with newly drilled holes using bolts and nuts at locations (B). Install longer bolt and nut at location (C) to secure magnetic reverser shield (D) and flighting to the drum.

### IMPORTANT:

Bolt heads must be installed on the inside of the auger to prevent damaging internal components.

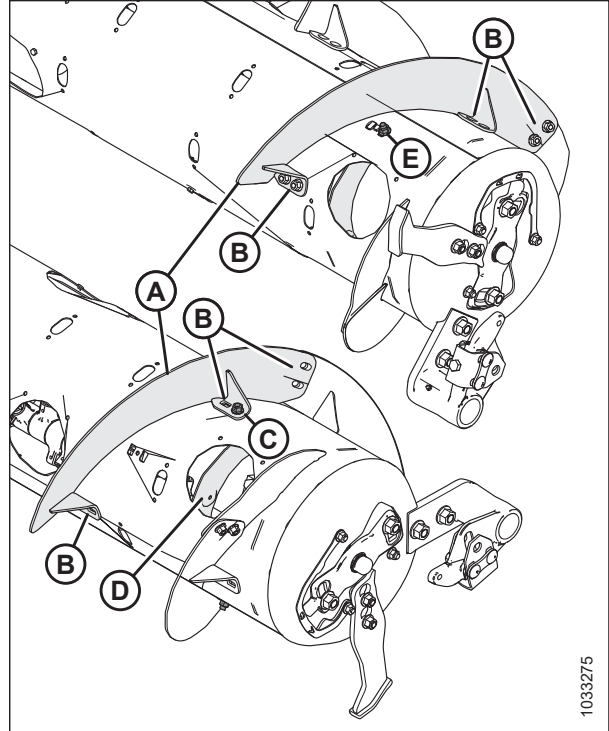

Figure 4.71: Right Side of Auger

15. Position two bolt-on flightings (A) on the left side of the auger as shown. Temporarily secure flightings with two carriage head and nuts at each location (B).

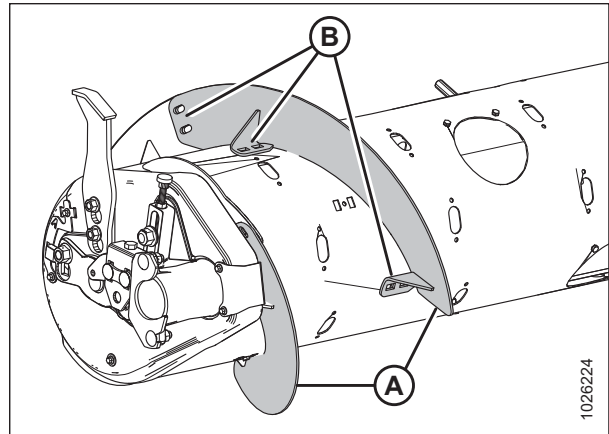

Figure 4.72: Left Side of Auger

## SETTING UP FLOAT MODULE AT DEALER

16. Position another bolt-on flighting (A) outboard of the temporarily installed flighting (B). Mark hole locations (C) of the bolt-on flighting onto the temporarily installed bolt-on flighting.
17. Remove temporarily installed bolt-on flighting (B) from the auger and drill two 11 mm (7/16 in.) holes at the marked locations.
18. Install bolt-on flighting (B) with newly drilled holes using six carriage head and nuts

### IMPORTANT:

Carriage bolt heads must be installed on the inside of the auger to prevent damaging internal components.

19. Repeat Step 16, page 71 to Step 18, page 71 with the remaining bolt-on flighting on the left side of the auger.
20. Place bolt-on flighting (A) outboard of other flighting (B) on the left side of the auger, as shown.
21. Temporarily secure bolt-on flighting (A) with two button head bolts and nuts at location (C).

22. Stretch flighting (A) to fit auger tube as shown. Use slotted holes on flighting to get the best fit around the auger tube.

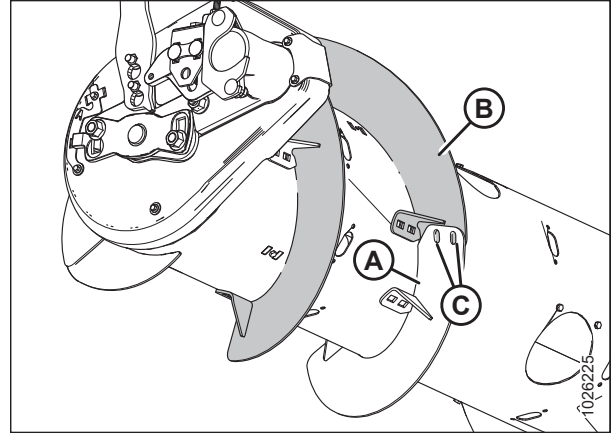

Figure 4.73: Left Side of Auger

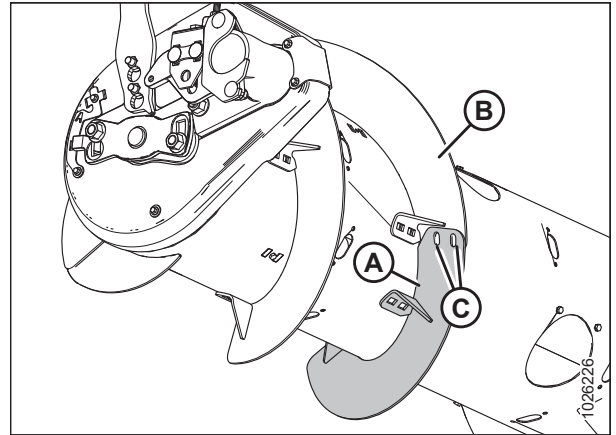

Figure 4.74: Left Side of Auger

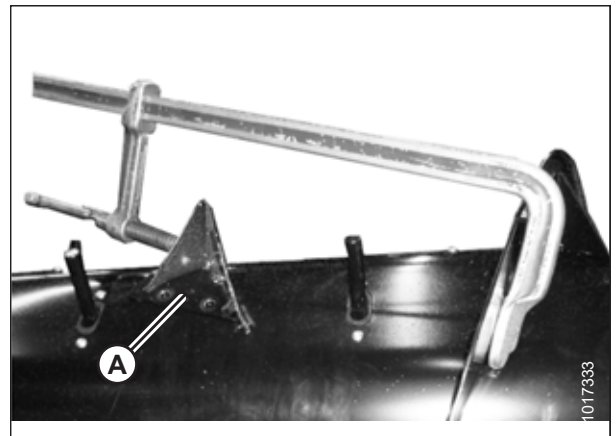

Figure 4.75: Flighting Stretched Axially

## SETTING UP FLOAT MODULE AT DEALER

23. With flighting in the desired position, mark hole locations (A) on auger tube.
24. Remove flighting (B) from auger, and drill 11 mm (7/16 in.) holes at marked locations (A) on auger tube.
25. Remove nearest access cover(s). Retain for reinstallation.
26. Install bolt-on flighting (B) using two button head and nuts at location (C), and four flange head bolts (MD #152655) and nuts at locations (A).

### IMPORTANT:

Ensure bolt heads at location (C) are on the inboard (crop side) and nuts are on the outboard side of the flighting.

27. Repeat Step 20, page 71 to Step 26, page 72 for the remaining flighting on the left side of the auger.
28. Place bolt-on flighting (A) outboard of other flighting (B) on the right side of the auger as shown.
29. Temporarily secure bolt-on flighting (A) with two button head bolts and nuts at location (C).
30. Repeat Step 22, page 71 to Step 26, page 72 for both pieces of flighting on the right side of the auger.
31. Install flighting slot plugs in the holes previously used to mount flightings on the left and right sides of the auger, and secure with M6 bolts and tee nuts. Torque to 9 Nm (80 lbf-in).

### NOTE:

If plug bolts are **NOT** new, coat bolts with medium-strength threadlocker (Loctite® 243 or equivalent) prior to installation.

32. Torque all nuts and bolts attaching the flighting and the magnetic reverser shield to 47 Nm (35 lbf-ft) to eliminate deflection on the flighting, then retorque them to 61 Nm (45 lbf-ft).

### NOTE:

Flighting performs best when no gaps are present. If desired, use silicone sealant to fill the gaps.

33. Add or remove auger fingers to optimize feeding for your combine and crop conditions. For instructions, refer to [4.2.11 Installing Feed Auger Fingers, page 75](#) or [4.2.12 Removing Feed Auger Fingers, page 77](#).
34. If not adding or removing auger fingers, reinstall all access covers and secure with bolts. Coat bolts with medium-strength threadlocker (Loctite® 243 or equivalent) and torque to 9 Nm (80 lbf-in).

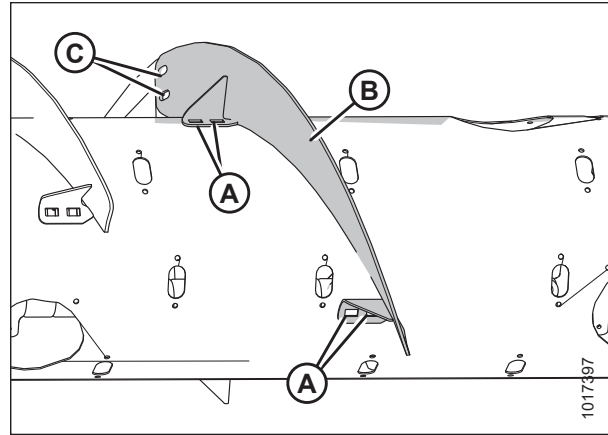

Figure 4.76: Left Side of Auger

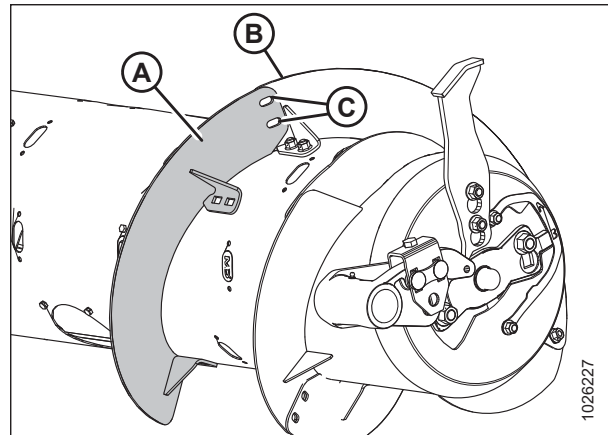

Figure 4.77: Right Side of Auger

### 4.2.10 Converting from Narrow Configuration to Ultra Narrow Configuration

Two flighting kits (MD #287032 or B6400<sup>2</sup>) and some hole-drilling are required to convert to this configuration. Extra hardware is included in these kits. Be sure to use the correct hardware at the correct location to prevent damage and to maximize performance.

**NOTE:**

Additional holes on the auger are needed before these flightings (A) can be installed.

**NOTE:**

All illustrations show the feed auger separated from the float module for clarity. The procedure can be performed with the feed auger installed in the float module.

**NOTE:**

Some parts have been removed from the illustrations for clarity.

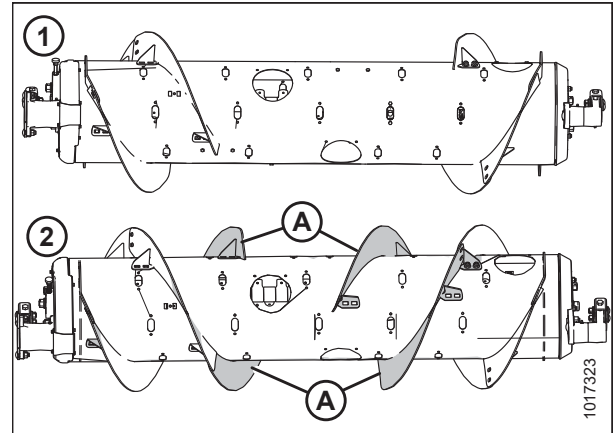

**Figure 4.78: Auger Configurations – Rear View**

1 - Narrow Configuration      2 - Ultra Narrow Configuration

1. Improve access and ease installation by removing the float module from the combine. For instructions, refer to the header operator’s manual or technical manual.
2. Place new bolt-on flighting (A) outboard of existing flighting (B) on the left side of the auger, as shown.
3. Mark hole locations (C) of new bolt-on flighting (A) onto existing bolt-on flighting (B).
4. Remove nearest access cover to existing bolt-on flighting (B). Retain hardware for reassembly.
5. Remove existing bolt-on flighting (B) from the auger. Retain hardware for reassembly.
6. Drill two 11 mm (7/16 in.) holes at the marked locations of existing bolt-on flighting (B).
7. Reinstall existing bolt-on flighting (B) on the auger.

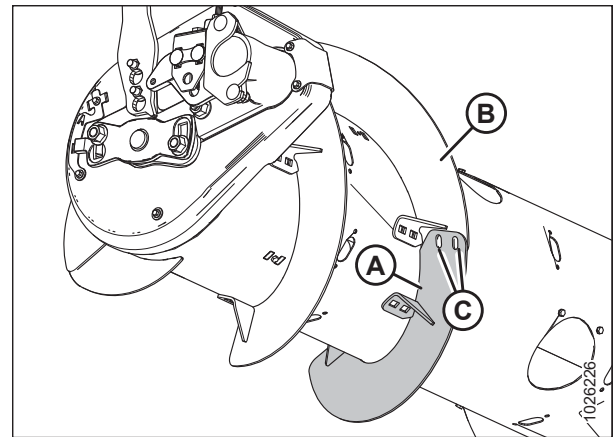

**Figure 4.79: Left Side of Auger**

**NOTE:**

Ensure carriage bolt heads are on the inside of the auger to prevent damage to internal components.

2. MD #287032 is available only through MacDon Parts. B6400 is available only through Whole Goods.

## SETTING UP FLOAT MODULE AT DEALER

- Place new bolt-on flighting (A) outboard of existing flighting (B) on the left side of the auger, as shown.
- Secure with two button head bolts and nuts at locations (C).

### IMPORTANT:

Ensure bolt heads are on the inboard (crop side) and nuts are on the outboard side of the flighting.

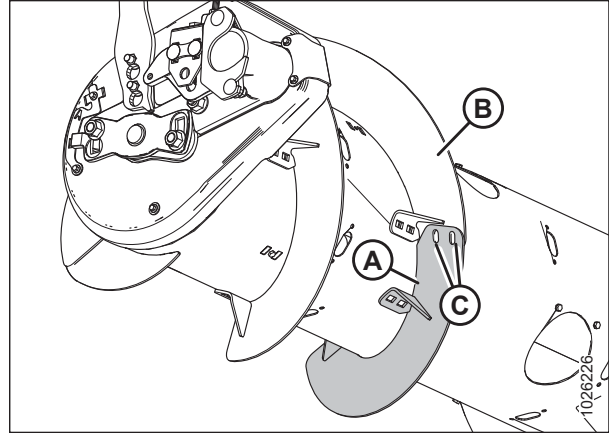

Figure 4.80: Left Side of Auger

- Stretch flighting (A) to fit auger tube as shown. Use slotted holes on flighting to get the best fit around the auger tube.

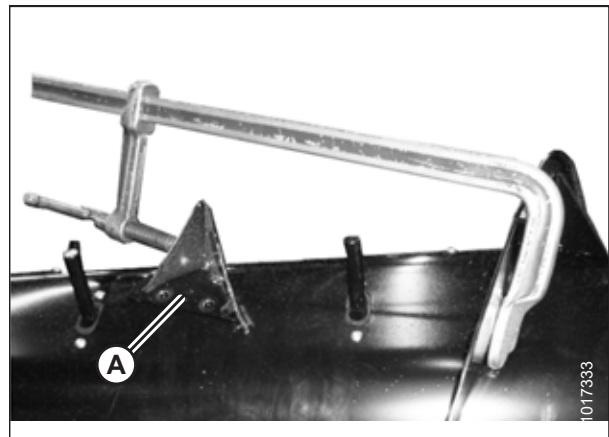

Figure 4.81: Flighting Stretched Axially

- With flighting in desired position, mark hole locations (A) and drill 11 mm (7/16 in.) holes in auger tube.
- Remove nearest access cover(s). Retain for reinstallation.
- Secure bolt-on flighting on newly drilled holes (A) using four flange head bolts and nuts at locations (A).
- Repeat Step 2, page 73 to Step 13, page 74 for the other flighting on the left side of the auger.

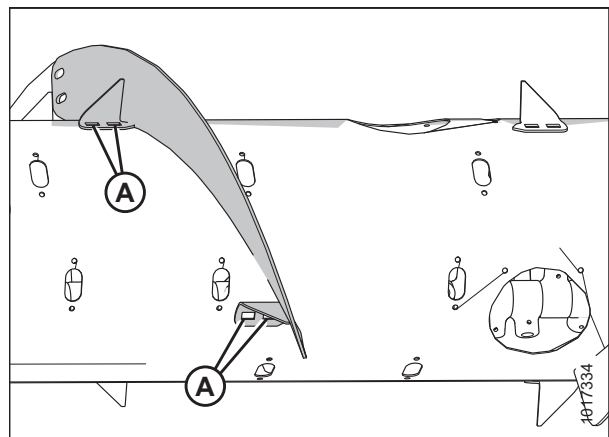

Figure 4.82: Flighting on Left Side of Auger

## SETTING UP FLOAT MODULE AT DEALER

- Place flighting (A) outboard of existing flighting (B) on the right side of the auger, as shown.

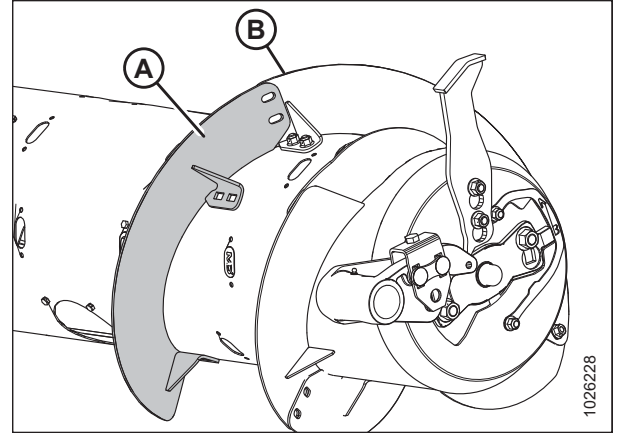

Figure 4.83: Flighting on Right Side of Auger

- Repeat Step 3, page 73 to Step 13, page 74 for both flightings on the right side of the auger.

### NOTE:

On the **RIGHT** side of the auger, bolt and nut at location (A) attach magnetic shield (B) to the auger drum and flighting (C). When removing flighting (C), keep bolt and nut (A) separate from the rest of the feed auger hardware because this bolt is slightly longer.

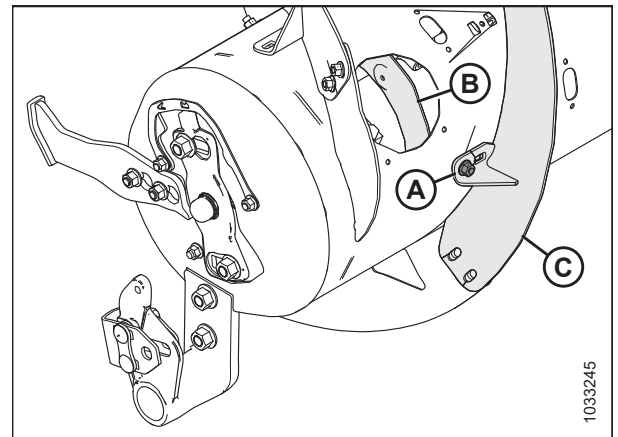

Figure 4.84: Reverser Shield on Right Side of Auger

- On both sides of the auger, install flighting slot plugs in the flighting mounting locations and secure with M6 bolts and tee nuts.

### NOTE:

If plug bolts are **NOT** new, coat bolts with medium-strength threadlocker (Loctite® 243 or equivalent) prior to installation.

- Torque all flighting nuts and bolts to 47 Nm (35 lbf-ft) to eliminate deflection on flighting, then torque nuts and bolts again to 61 Nm (45 lbf-ft).

### NOTE:

Flighting performs best when no gaps are present. If desired, use silicone sealant to fill the gaps.

- Add or remove auger fingers as necessary to optimize feeding for your combine and crop conditions. For instructions, refer to [4.2.11 Installing Feed Auger Fingers, page 75](#) or [4.2.12 Removing Feed Auger Fingers, page 77](#).
- If not adding or removing auger fingers, reinstall all access covers and secure with bolts. Coat bolts with medium-strength threadlocker (Loctite® 243 or equivalent) and torque to 9 Nm (80 lbf-in).

## 4.2.11 Installing Feed Auger Fingers

### IMPORTANT:

When installing additional fingers, ensure you install an equal number on each side of the auger.

## SETTING UP FLOAT MODULE AT DEALER

### NOTE:

Not all parts needed for this procedure are included in this kit and, depending on the original configuration of the feed auger, additional parts may need to be ordered. Refer to *4.2 FM100 Feed Auger Configurations, page 38* to see which parts are available.

1. Remove bolts (A) and access cover (B) closest to the finger you are removing. Retain parts for reinstallation.

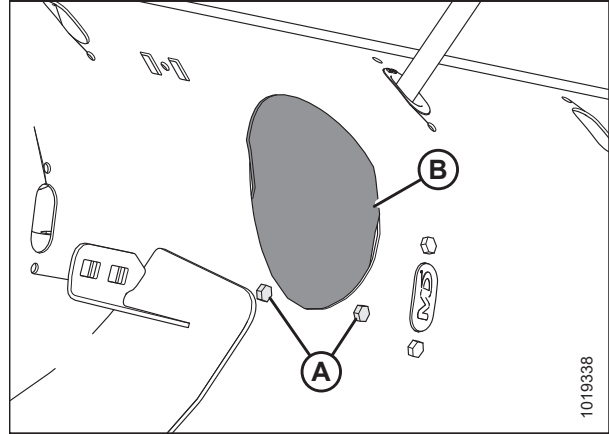

Figure 4.85: Auger Access Hole Cover

2. Remove two bolts (B), tee nuts (not shown), and plug (A).

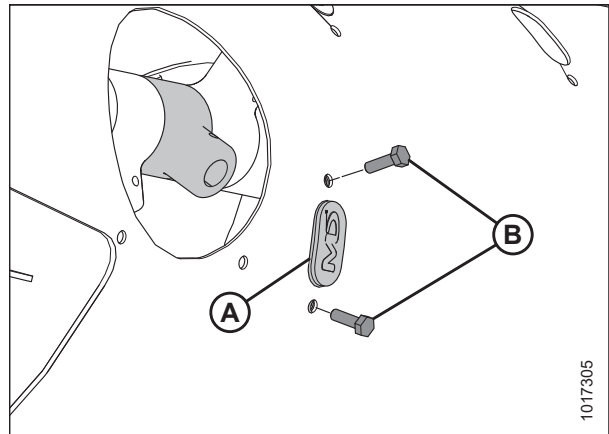

Figure 4.86: Auger Finger Hole

3. Install guide (B) as follows:

### NOTE:

Bolts (A) come with a threadlocker patch that will wear off if the bolts are removed. If reinstalling bolts (A), apply medium-strength threadlocker (Loctite® 243 or equivalent) before installation.

Insert guide (B) from inside the auger and secure it with bolts (A) and tee nuts (not shown).

### IMPORTANT:

Always install a new guide when replacing a solid finger.

4. Torque bolts (A) to 9 Nm (80 lbf-in).

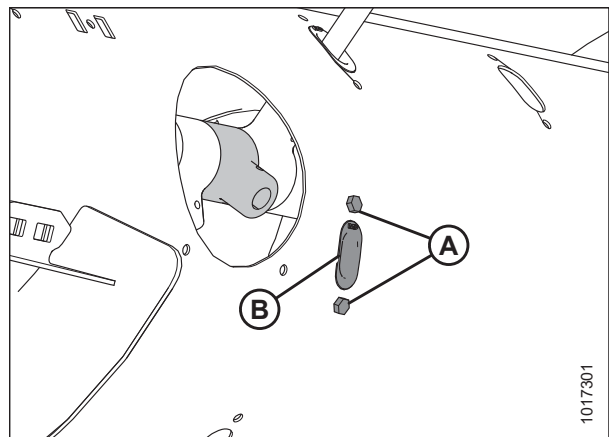

Figure 4.87: Auger Finger Hole



## SETTING UP FLOAT MODULE AT DEALER

5. Place solid finger (A) inside the drum. Insert solid finger (A) up through the bottom of guide (B) and insert other end of finger into holder (C).
6. Secure the finger by inserting hairpin (D) into the holder. Make sure the round end (S-shaped side) of the hairpin faces the chain drive side of the auger. Make sure the closed end of the hairpin points in the direction of auger-forward rotation.

**NOTE:**

Position the hairpin correctly as described in this step to prevent the hairpin from falling out during operation. If fingers are lost, the header might not be able to feed crop into the combine properly. Fingers that fall into the drum might damage internal components.

7. Install access cover (B) as follows:

**NOTE:**

Bolts (A) come with a threadlocker patch that will wear off if the bolts are removed. If reinstalling bolts (A), apply medium-strength threadlocker (Loctite® 243 or equivalent) before installation.

Secure access cover (B) in place with bolts (A). Torque bolts to 9 Nm (80 lbf-in).

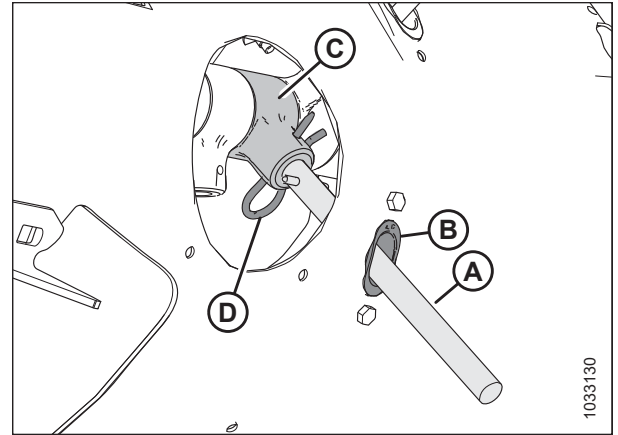

Figure 4.88: Auger Finger

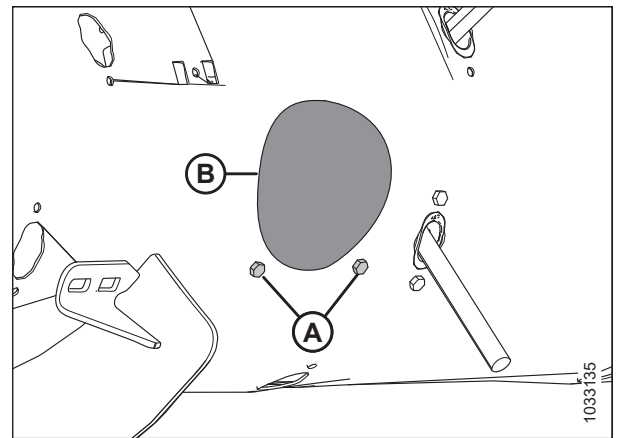

Figure 4.89: Auger Access Hole Cover

### 4.2.12 Removing Feed Auger Fingers

**IMPORTANT:**

When removing auger fingers, work from outside inward. Make sure there is an equal number of fingers on both sides of the auger when complete.

1. Remove bolts (A) and access cover (B) closest to the finger you are removing. Retain parts for reinstallation.

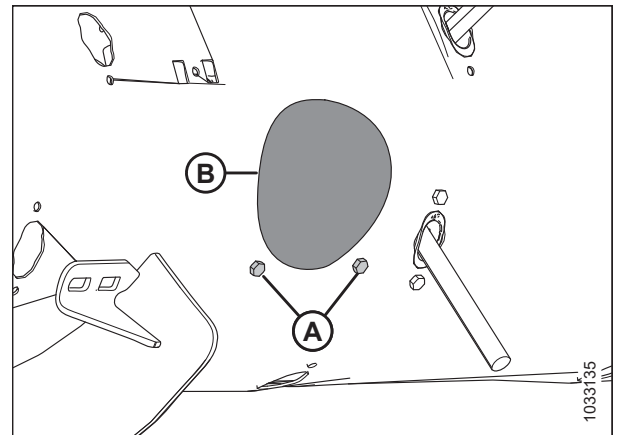

Figure 4.90: Auger Access Hole Cover

## SETTING UP FLOAT MODULE AT DEALER

2. Remove hairpin (A). Pull finger (B) out of finger holder (C).

Push finger (B) through guide (D) and into the drum. Pull the finger out of the drum access hole.

If the finger broke, remove any remnants from holder (C) and from inside the drum.

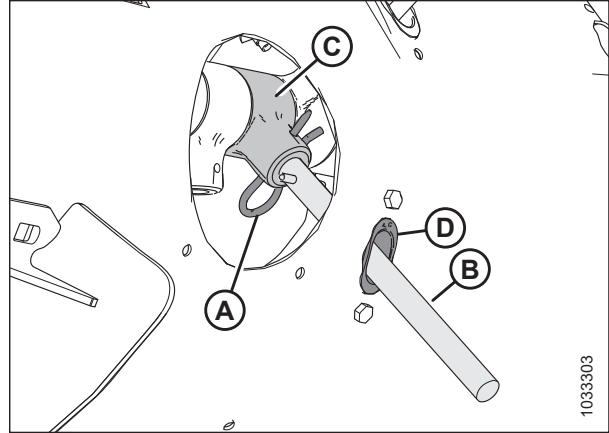

Figure 4.91: Auger Finger

3. Remove and retain two bolts (A) and tee nuts (not shown) securing finger guide (B) to the auger. Remove guide (B).

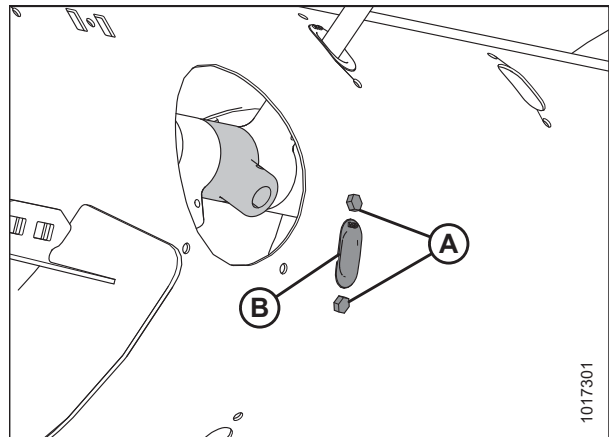

Figure 4.92: Auger Finger Hole

4. Install plug (A) as follows:

**NOTE:**

Bolts (B) come with a threadlocker patch that will wear off if the bolts are removed. If reinstalling bolts (B), apply medium-strength threadlocker (Loctite® 243 or equivalent) before installation.

Position plug (A) into the hole from inside the auger. Secure with two M6 hex head bolts (B) and tee nuts. Torque to 9 Nm (80 lbf-in).

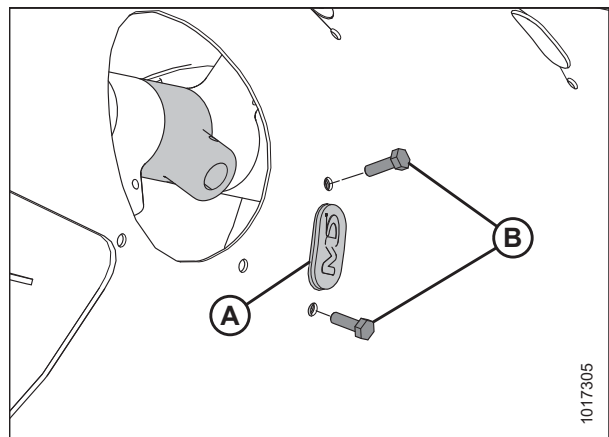

Figure 4.93: Plug

## SETTING UP FLOAT MODULE AT DEALER

5. Install access cover (B) as follows:

**NOTE:**

Bolts (A) come with a threadlocker patch that will wear off if the bolts are removed. If reinstalling bolts (A), apply medium-strength threadlocker (Loctite® 243 or equivalent) before installation.

Secure access cover (B) in place with bolts (A). Torque bolts to 9 Nm (80 lbf-in).

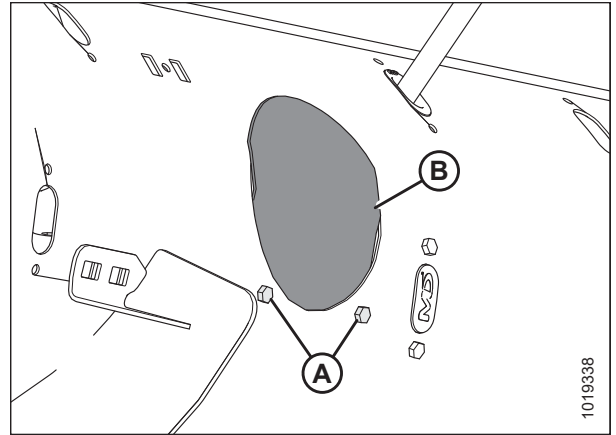

Figure 4.94: Auger Access Hole Cover

## 4.3 FM100 Stripper Bars and Feed Deflectors

### 4.3.1 Removing Stripper Bars

Stripper bar kits may have been supplied with your header to improve feeding in certain crops such as rice. They are **NOT** recommended for cereal crops.

**NOTE:**

The following procedure does **NOT** apply to New Holland CR960, 9060, 970, 9070, and 9080 combines. For these combines, refer to [4.3.2 CR Feeder Deflectors, page 80](#).

If necessary, remove auger stripper bars as follows:

1. Remove four bolts (A) and nuts securing bars (B) to float module frame. Remove bars.
2. Repeat for opposite set of stripper bars.

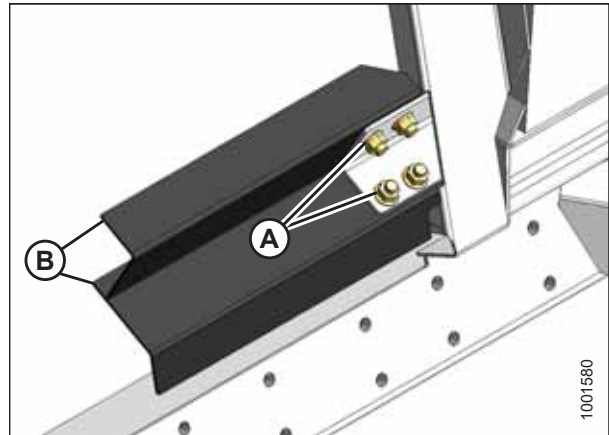

Figure 4.95: Auger Stripper Bar

### 4.3.2 CR Feeder Deflectors

This section is for New Holland CR combines only. If operating a New Holland CX combine, remove feed deflectors.

**For New Holland CR combines only:** Short feeder deflectors have been factory-installed on the float module to improve feeding into the feeder house. Remove the feeder deflectors if necessary. For instructions, refer to [4.3.3 Replacing Feed Deflectors on New Holland CR Combines, page 81](#).

Long feeder kits are provided for narrow feeder house combines and can be installed to replace the short feeder deflectors.

Table 4.1 FM100 Feeder Kits for CR Model Combines

Feeder House Size	Feeder Kit Size	MacDon Part Number
1250–1350 mm (49–65 in.)	Short: 200 mm (7 7/8 in.)	MD #213613, 213614
1100 mm (43-1/2 in.) and below	Long: 325 mm (12 13/16 in.)	MD #213592, 213593

### 4.3.3 Replacing Feed Deflectors on New Holland CR Combines

This section is for New Holland CR combines only. If operating a New Holland CX combine, remove feed deflectors.

1. Remove two bolts and nuts (B) securing feed deflector (A) to the float module frame, and remove the feed deflector.
2. Position replacement feed deflector (A), and secure with bolts and nuts (B) (ensure the nuts are facing the combine). Do **NOT** tighten nuts.

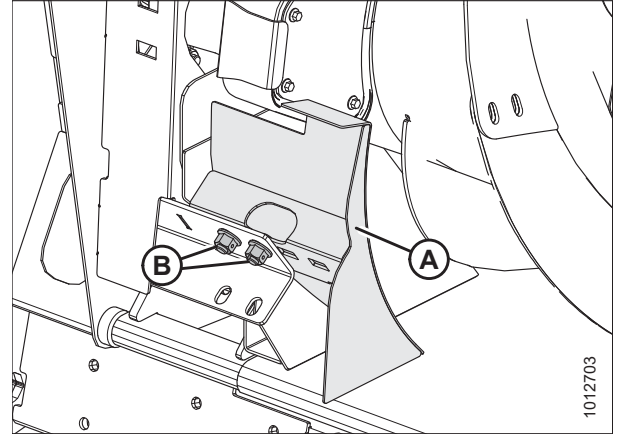

Figure 4.96: Feed Deflector

3. Adjust deflector (A) so that distance (C) between pan and deflector is 4–6 mm (5/32–1/4 in.).
4. Tighten nuts (B).
5. Repeat for opposite deflector.
6. Attach header to the combine. For instructions, refer to Chapter 5 *Attaching Header to Combine*, page 83.
7. After attaching the header to the combine, fully extend the center-link and check the gap between the deflector and pan. Maintain the 4–6 mm (5/32–1/4 in.) gap.

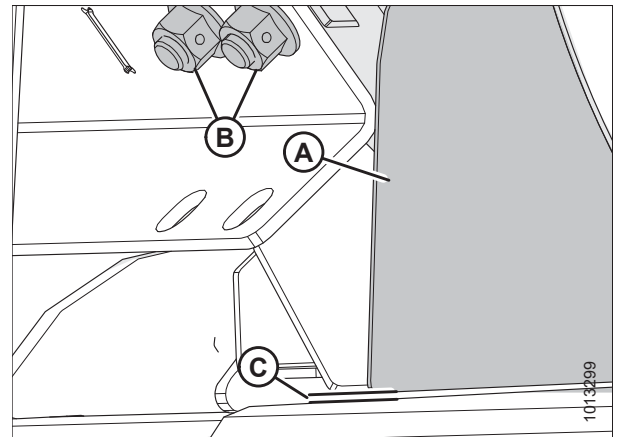

Figure 4.97: Pan and Deflector Distance



## Chapter 5: Attaching Header to Combine

The procedures for attaching the header to a combine vary depending on the combine model. Refer to the following table for the appropriate procedure:

**Table 5.1 Combine Model Header Attachment Procedures**

Combine	Refer to
AGCO Gleaner R and S Series; Challenger 660, 670, 680B, 540C, and 560C; Massey Ferguson 9690, 9790, 9895, 9520, 9540, and 9560	<i>5.1 AGCO (Challenger, Gleaner, and Massey Ferguson) Combines, page 83</i>
AGCO IDEAL™	<i>5.2 AGCO IDEAL™ Series Combines, page 91</i>
Case IH 7010, 8010, 7120, 8120, 9120, 5088, 6088, 7088, 5130, 6130, 7130, 7230, 8230, and 9230	<i>5.3 Case IH Combines, page 94</i>
CLAAS 500, 600, and 700 (R Series)	<i>5.5 CLAAS Combines, page 116</i>
John Deere 60, 70, S, and T Series	<i>5.4 John Deere Combines, page 101</i>
New Holland CR and CX	<i>5.6 New Holland Combines, page 121</i>

### IMPORTANT:

Ensure applicable functions (automatic header height control [AHHC], Draper Header Option, Hydraulic Center-Link Option, Hydraulic Reel Drive, etc.) are enabled on the combine and in the combine computer. Failure to do so may result in improper header operation.

## 5.1 AGCO (Challenger, Gleaner, and Massey Ferguson) Combines

### 5.1.1 Installing Reel Fore-Aft / Header Tilt Selector Switch and Harness

Gleaner combines prior to model year 2014 are not equipped to accommodate hydraulic reel fore-aft and header tilt options. The following additional items are required and not supplied by MacDon:

- Valve (A) (AGCO #71389745)
- Hoses
- Electrical components
- Couplers

#### NOTE:

Model year 2014 and later Gleaner combines will have the above parts factory-installed.

To enable the reel fore-aft and header tilt options, install the switch and harness as follows:

### WARNING

**To avoid injury or death from unexpected start-up of machine, always stop the engine and remove the key from the ignition before leaving the operator's seat for any reason.**

1. Lower and tilt the combine feeder house all the way forward if equipped. This will ensure that the electrical harnesses will be installed with sufficient slack.
2. Shut down the engine, and remove the key from the ignition.

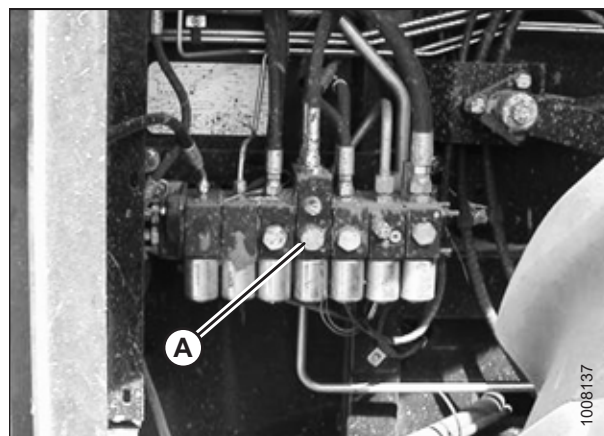

**Figure 5.1: Converted Gleaner R72 Shown**

## ATTACHING HEADER TO COMBINE

3. Disconnect the negative cable from the combine battery. For instructions, refer to the combine manual.

### IMPORTANT:

If you do not disconnect the battery before connecting the cab draper control harness to the combine's auxiliary power connectors, electrical components may be damaged.

4. At the multicoupler, connect the cab draper extension harness (MD #304211) to the float module as follows:
  - **Connector C3A** – If the In-Cab Side Draper Speed Control kit has been installed, plug connector C3B on the valve drive harness into connector C3A. If the In-Cab Side Draper Speed Control kit has not been installed, leave C3A unconnected.
  - **Connector C5B** – Plug connector C5B (A) into connector C5A on the completion harness.

### NOTE:

Connectors C3A and C5B are shipped with caps. The caps need to be removed in order to connect these connectors.

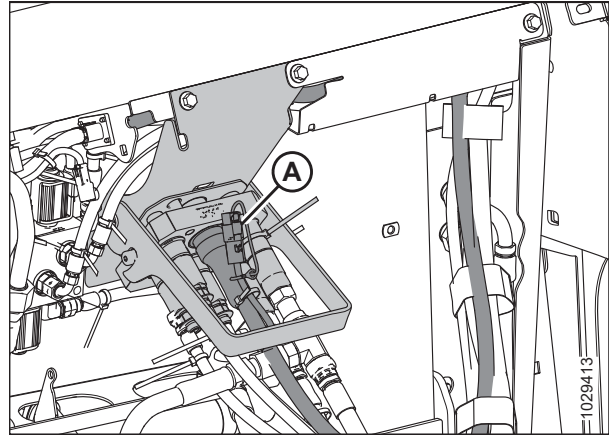

Figure 5.2: Multicoupler on Float Module

5. Route cab draper extension harness (A) along the side of the combine feeder house to the underside of the combine cab.



Figure 5.3: Switch Harness Routing

6. Use cable ties (MD #16661) to fasten cab draper extension harness (A) to the main harness on the left side of the feeder house and under the cab floor at locations (B).

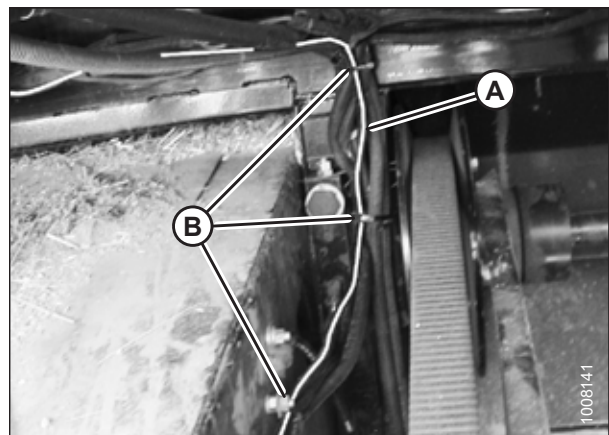

Figure 5.4: Left Side of Feeder House



## ATTACHING HEADER TO COMBINE

7. Use cable ties (MD #16661) to fasten cab draper extension harness (A) to the main harness under the cab floor at location (B).

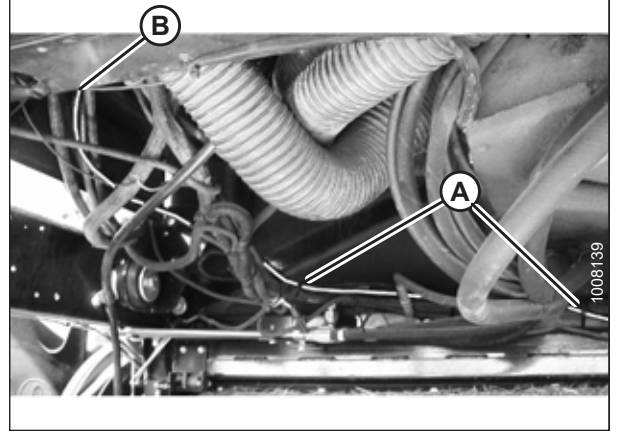

Figure 5.5: Harness under Right Side of Cab Floor

8. Route cab draper extension harness (A) under the cab, through the cab floor, and into console at foam seal (B).

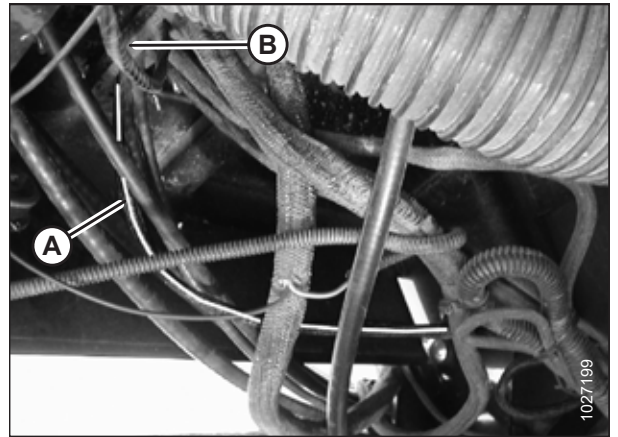

Figure 5.6: Harness through Cab Floor

## ATTACHING HEADER TO COMBINE

9. Inside the cab, remove console cover as shown.
10. Connect the cab draper extension harness to the cab draper control harness (MD #304210) as follows:
  - Plug C4B into C4A.
  - Plug C6B into C6A.
11. Connect the cab draper control harness to the power supply inside the console at location (A).
  - The red wire from the inline fuse goes to switched power supply (A).
  - The double black wire goes to the ground.

### IMPORTANT:

Connecting the draper control harness to an unswitched power supply or cigarette lighter (using harness MD #220570, provided in the kit) will supply constant power to the header tilt side of the solenoid valve and drain the combine battery during extended shutdown periods.

12. Route the draper control harness through grommet (B), and then replace cover.
13. Insert rocker switch (MD #109064) into rocker switch support (MD #158377). Ensure the lugs on the underside of the support have secured the switch.
14. Mount rocker switch support onto console (A) in a comfortable position.
15. Connect harness to switch with red wire to center terminal (B), and white wire to either outer terminal (C).
16. If the In-Cab Side Draper Speed Control kit has been installed, connect connector P551 to the speed control rheostat. If the In-Cab Side Draper Speed Control kit has not been installed, leave connector P551 unconnected.
17. Reconnect the battery cable.
18. Operate the switch to select either REEL FORE-AFT or HEADER TILT function.

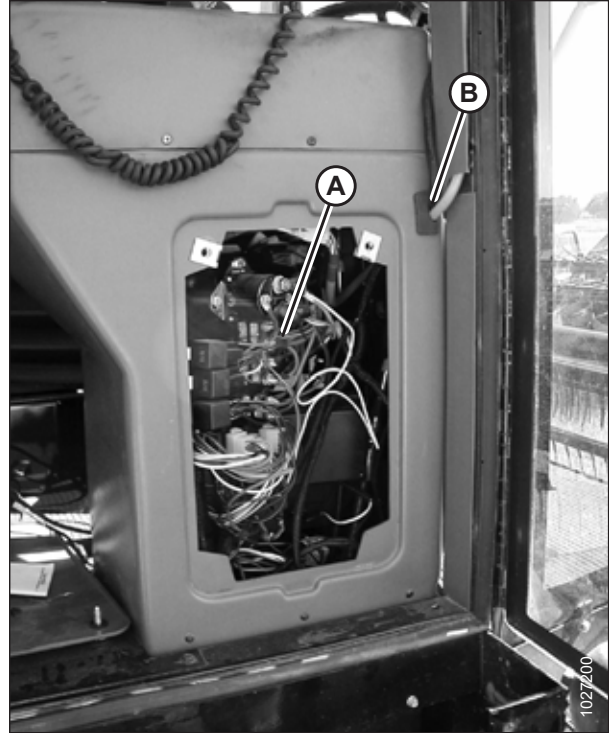

Figure 5.7: Console with Cover Removed

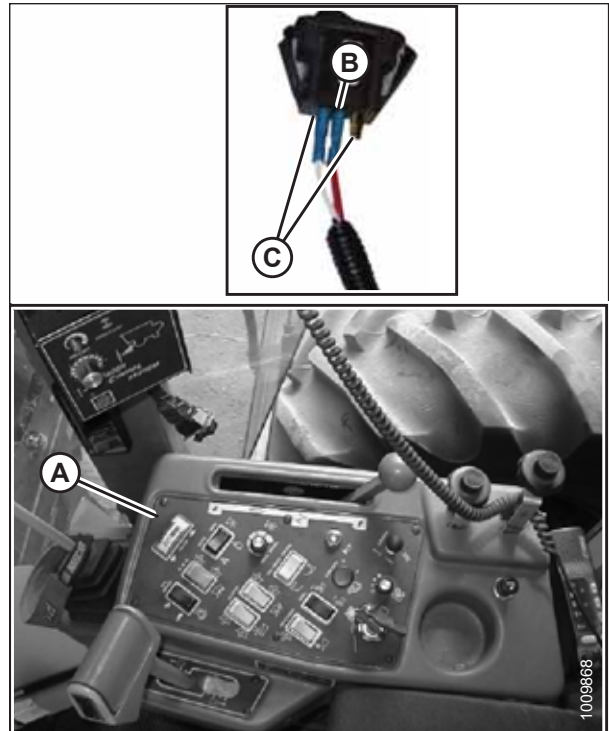

Figure 5.8: Switch and Console

### 5.1.2 Attaching Header to an AGCO (Challenger, Gleaner, or Massey Ferguson) Combine

#### WARNING

To avoid injury or death from unexpected start-up of machine, always stop the engine and remove the key from the ignition before leaving the operator's seat for any reason.

1. Shut down the engine, and remove the key from the ignition.
2. Use lock handle (B) to retract lugs (A) at the base of the feeder house.

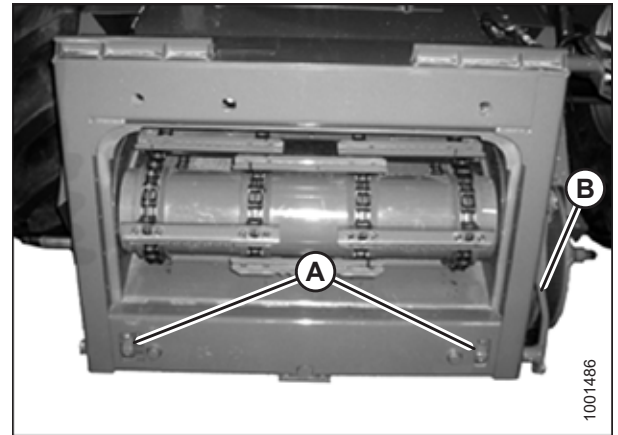

Figure 5.9: AGCO Group Feeder House

#### WARNING

Never start or move the machine until you are sure all bystanders have cleared the area.

3. Start the engine and slowly approach the header until the feeder house is directly under float module top cross member (A) and alignment pins (C) (refer to Figure 5.11, page 87) on the feeder house are aligned with holes (B) in the float module frame.

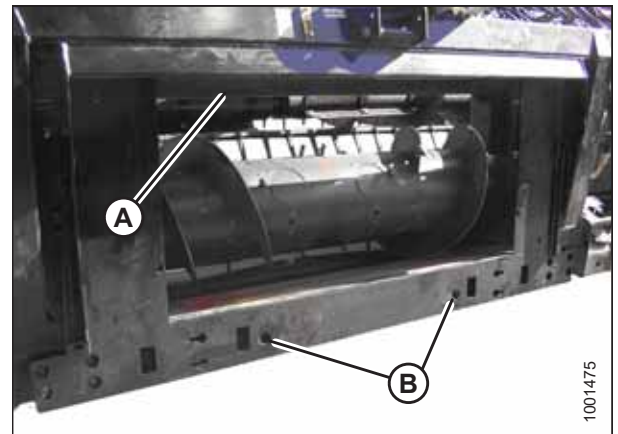

Figure 5.10: Float Module

#### NOTE:

Your combine feeder house may not be exactly as shown.

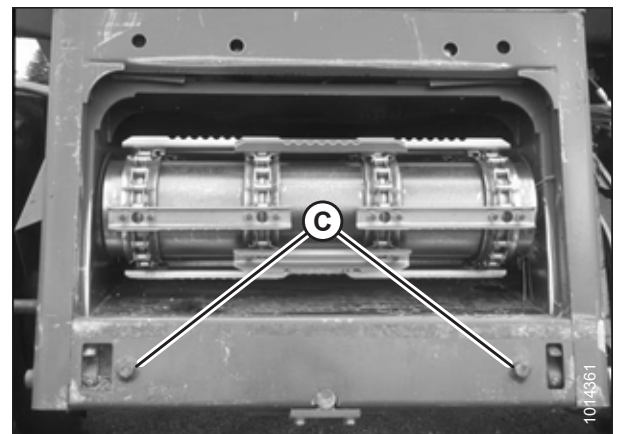

Figure 5.11: AGCO Group Alignment Pins

## ATTACHING HEADER TO COMBINE

4. Raise the feeder house slightly to lift the header, ensuring feeder house saddle (A) is properly engaged in the float module frame.
5. Shut down the engine, and remove the key from the ignition.



Figure 5.12: Feeder House and Float Module

6. Use lock handle (B) to engage lugs (A) with the float module.

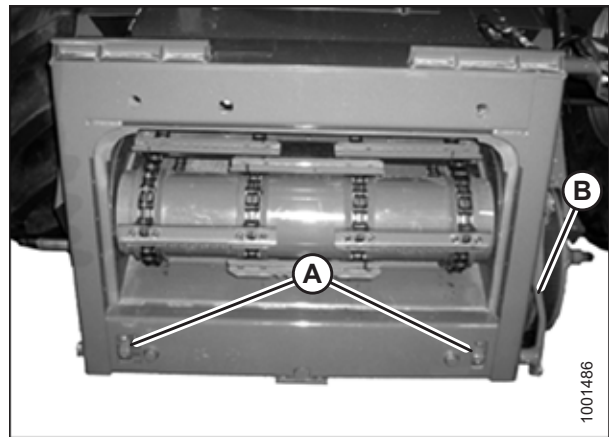

Figure 5.13: AGCO Group Feeder House

### WARNING

Never start or move the machine until you are sure all bystanders have cleared the area.

7. Start the engine. For instructions, refer to the combine operator's manual.
8. Lower the header fully.

#### NOTE:

The float module is equipped with a multicoupler that connects to the combine. If your combine is equipped with individual connectors, a multicoupler kit (single-point connector) must be installed. Refer to Table 5.2, page 88 for a list of kits and installation instructions that are available through your combine Dealer.

Table 5.2 Multicoupler Kits

Combine	AGCO Kit Number
Challenger	71530662
Gleaner R/S Series	71414706
Massey Ferguson	71411594

## ATTACHING HEADER TO COMBINE

9. Raise handle (A) to release multicoupler (B) from float module.

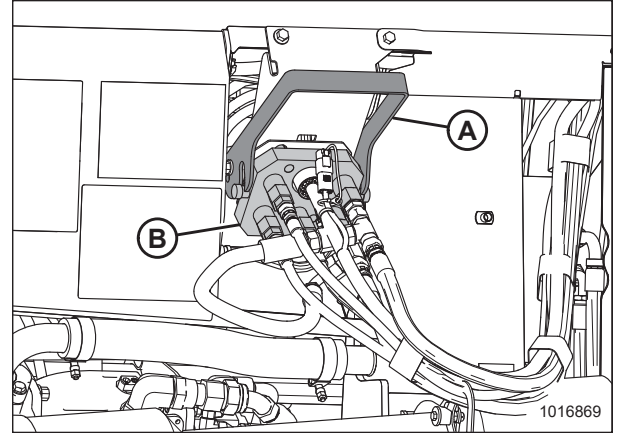

Figure 5.14: Float Module Multicoupler

10. Push handle (A) on the combine to the fully-open position.
11. Clean the mating surfaces of multicoupler (B) and receptacle if necessary.

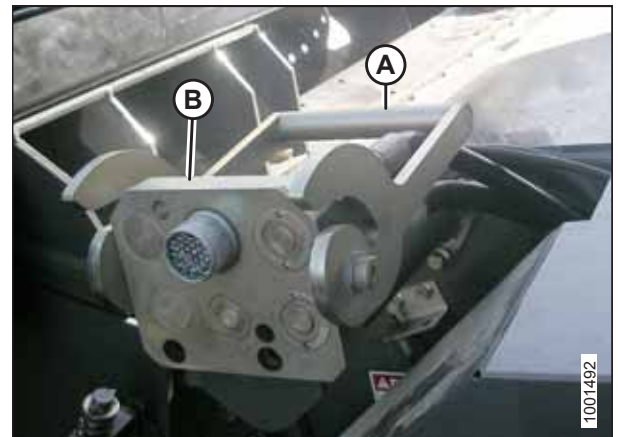

Figure 5.15: Combine Receptacle

12. Position multicoupler (A) onto the combine receptacle, and pull handle (B) to fully engage the multicoupler into the receptacle.
13. Connect reel fore-aft/header tilt selector harness (C) to combine harness (D).

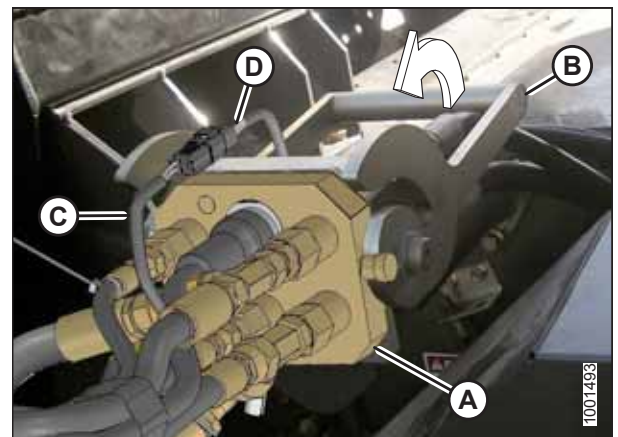

Figure 5.16: Multicoupler

## ATTACHING HEADER TO COMBINE

14. Detach safety chain (C) from support bracket (B).
15. Pull collar (D) back to release driveline (A) from support bracket.

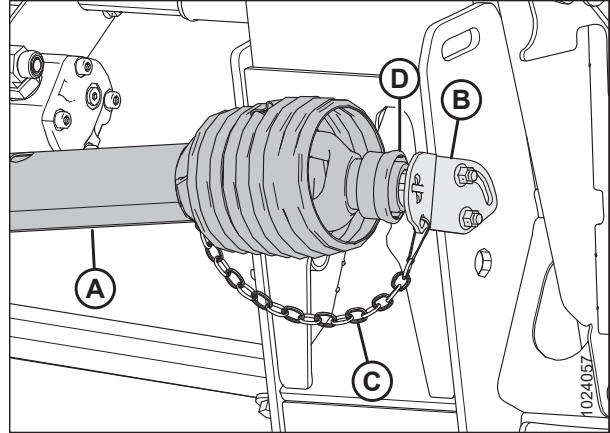

Figure 5.17: Driveline

16. Pull back collar (A) on the end of the driveline, and push the driveline onto combine output shaft (B) until the collar locks.
17. Proceed to [5.7 Completing Header Assembly, page 126](#).

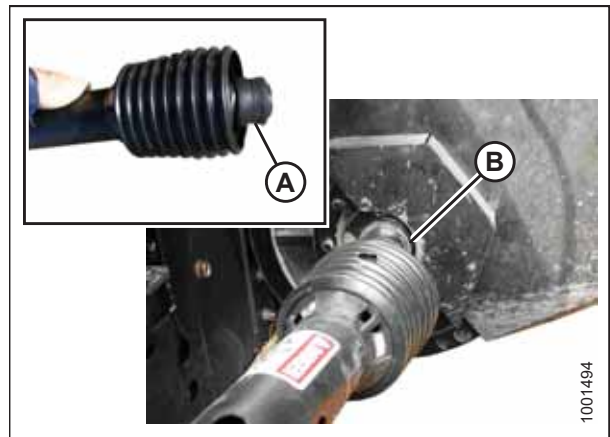

Figure 5.18: Driveline

## 5.2 AGCO IDEAL™ Series Combines

### 5.2.1 Attaching Header to an AGCO IDEAL™ Series Combine

#### WARNING

To avoid bodily injury or death from unexpected startup of machine, always stop the engine and remove the key from the ignition before leaving the operator's seat for any reason.

1. Shut down the engine, and remove the key from the ignition.
2. Pull lever (A) up to retract pins (B) at the bottom left and right sides of the feeder house.
3. Start the engine. For instructions, refer to the combine operator's manual.

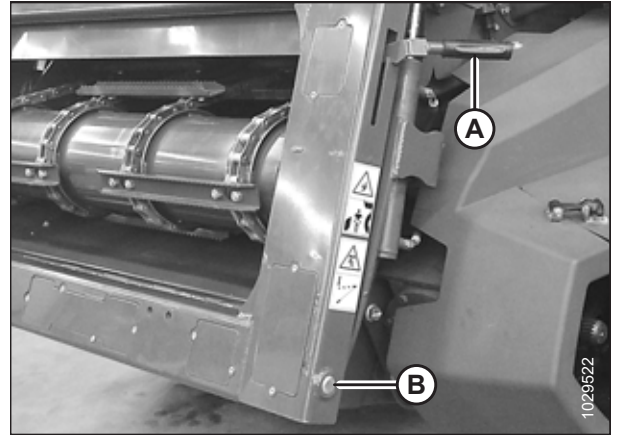

Figure 5.19: Feeder House

4. Drive the combine slowly up to the header until the feeder house is directly under top beam (A), and pins (B) are under hooks (C) on the transition frame.

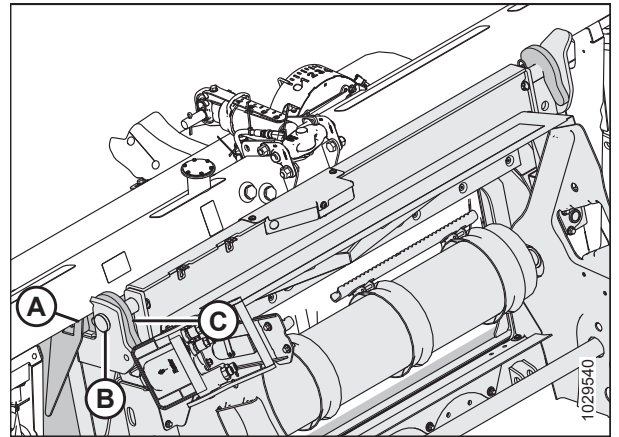

Figure 5.20: Feeder House

## ATTACHING HEADER TO COMBINE

5. Raise feeder house until transition frame top beam (A) is fully resting on the feeder house. Raise the header slightly off the ground.

### IMPORTANT:

The full weight of the header must be on the feeder house, **NOT** on pins (B).

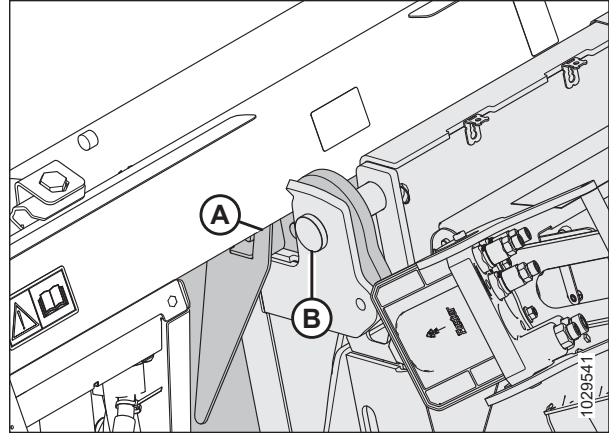

Figure 5.21: Top Beam Resting on Feeder House

6. Position bottom of feeder house so that locking pins (B) align with the holes in mount (C).
7. Push lever (A) down to extend locking pins (B) so they engage in mount (C).

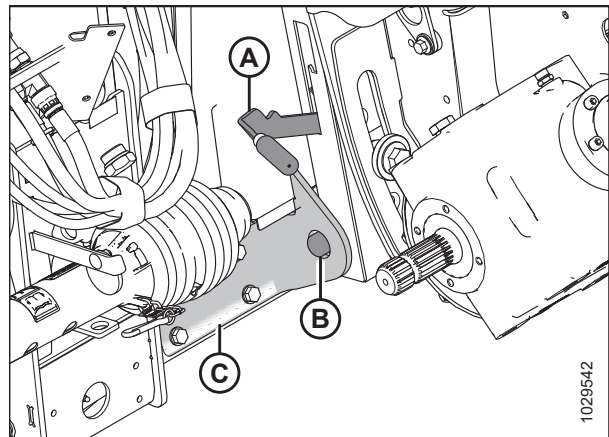

Figure 5.22: Feeder House Locking Pins

8. Rotate lock disc (A) upward and remove driveline (B) from the support.

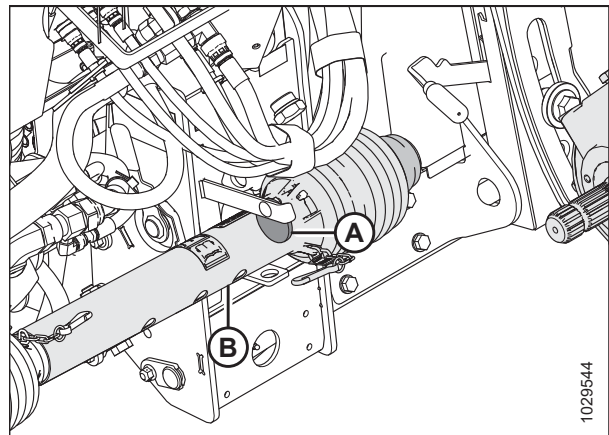

Figure 5.23: Driveline in Storage Position



## ATTACHING HEADER TO COMBINE

9. Pull back collar (A) on end of driveline and push onto combine output shaft (B) until collar locks.

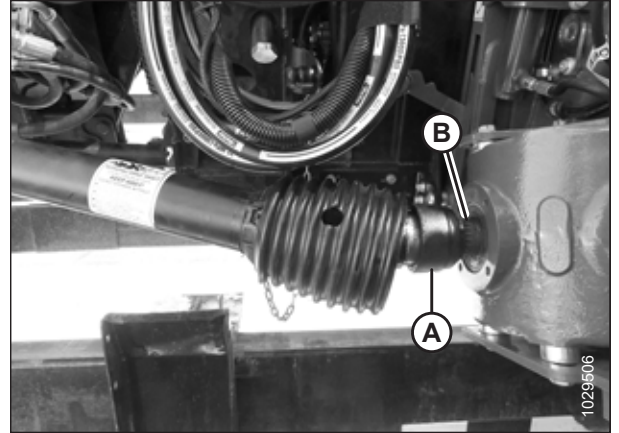

Figure 5.24: Connecting Driveline to Combine

10. Lower handle (A) to release multicoupler (B) from header.
11. Open cover (C) on the combine receptacle.
12. Push handle (D) to fully open position.
13. Clean mating surfaces of coupler and receptacle if necessary.

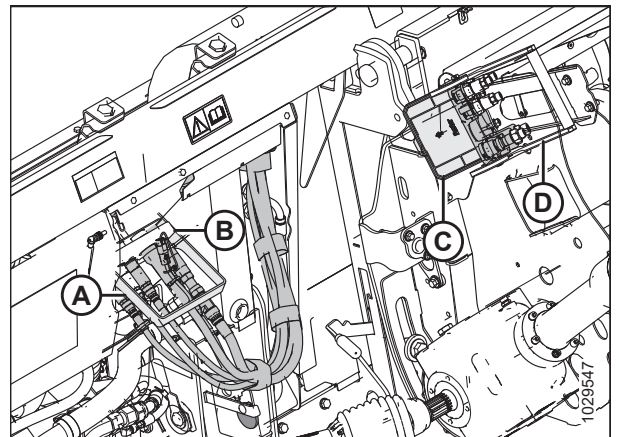

Figure 5.25: Multicoupler Receptacles

14. Position coupler (A) onto combine receptacle, and pull handle (B) to fully engage multicoupler into receptacle.

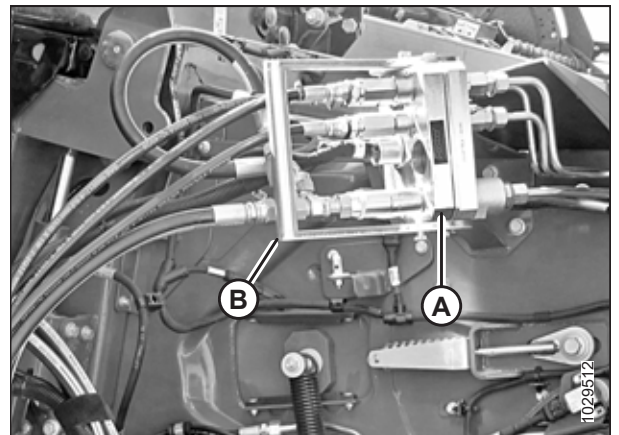

Figure 5.26: Multicoupler

## 5.3 Case IH Combines

### 5.3.1 Attaching Header to Case IH Combine

#### WARNING

To avoid injury or death from unexpected start-up of machine, always stop the engine and remove the key from the ignition before leaving the operator's seat for any reason.

1. Shut down the engine, and remove the key from the ignition.
2. On the upper left side of the combine float module, remove nut (A), washer, spring, and lever (B).

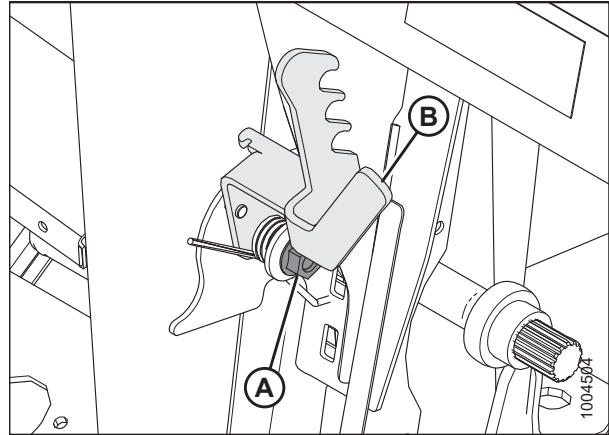

Figure 5.27: Combine Float Module Upper Left Side

3. Position lever (A) onto stud (B).

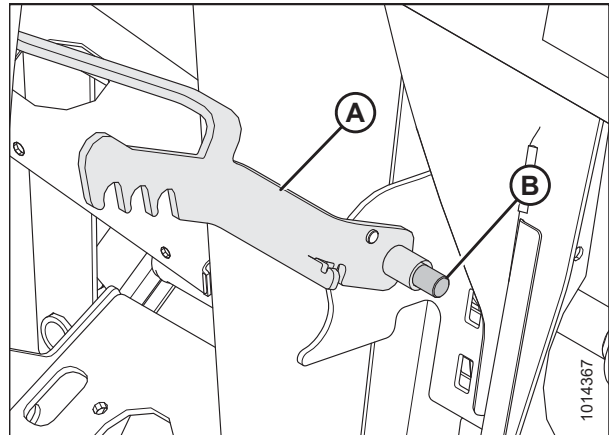

Figure 5.28: Combine Float Module Upper Left Side

## ATTACHING HEADER TO COMBINE

4. Place spring arm (C) into hook on lever (B) to preload it, and tighten nut (A) with washer onto the float module.

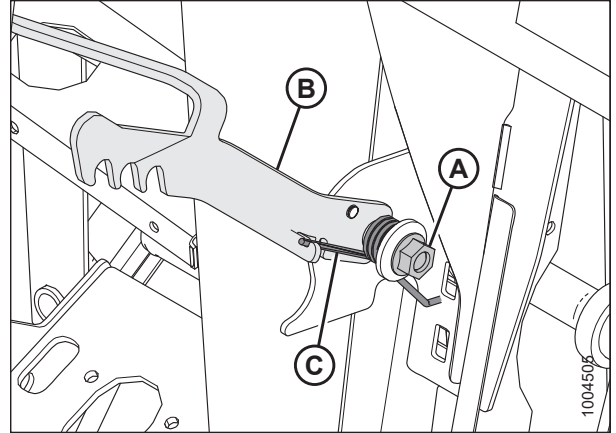

Figure 5.29: Combine Float Module Left Side

5. On the combine, ensure lock handle (A) is positioned so hooks (B) can engage the float module.

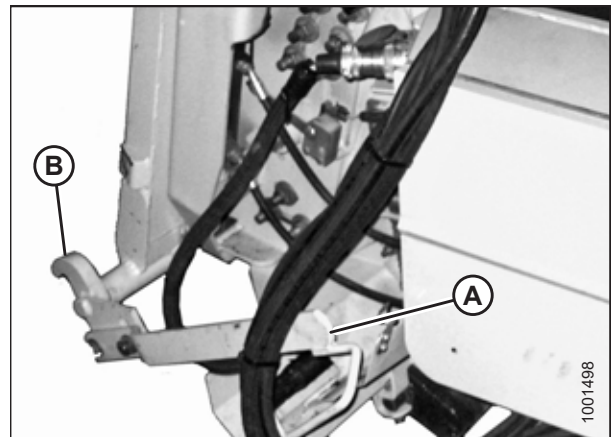

Figure 5.30: Feeder House Locks

### **WARNING**

Never start or move the machine until you are sure all bystanders have cleared the area.

6. Start the engine and slowly drive the combine up to the header until feeder house saddle (A) is directly under float module top cross member (B).
7. Raise the feeder house slightly to lift the header, ensuring the feeder saddle is properly engaged in the float module frame.
8. Shut down the engine, and remove the key from the ignition.

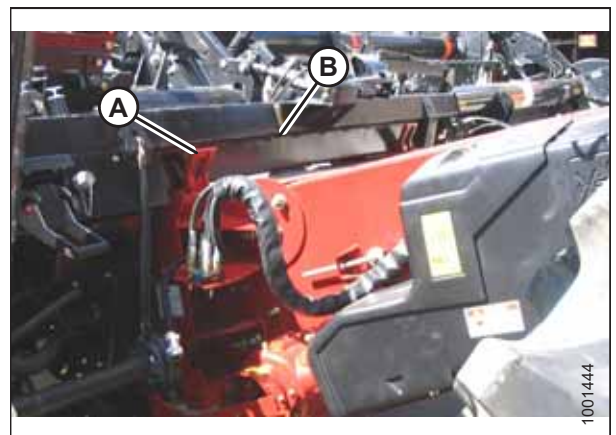

Figure 5.31: Combine and Float Module

## ATTACHING HEADER TO COMBINE

9. On the left side of the feeder house, lift lever (A) on the float module and push handle (B) on the combine to engage locks (C) on both sides of the feeder house.
10. Push down on lever (A) so the slot in the lever engages the handle and locks the handle in place.
11. If lock (C) does not fully engage the pin on the float module, loosen bolts (D) and adjust lock. Retighten bolts.

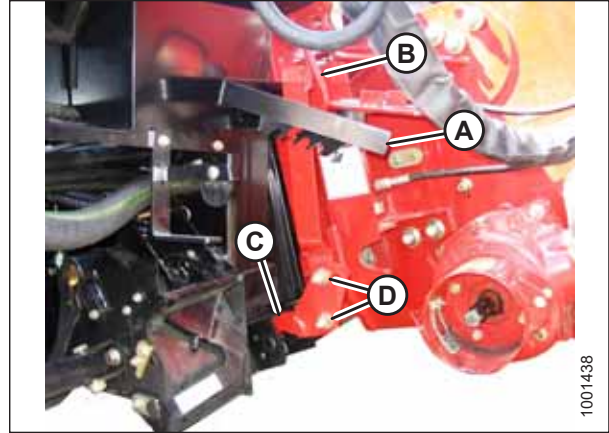

Figure 5.32: Combine and Float Module

12. Open the cover on receptacle (A) located on the left side of the float module.
13. Press lock button (B) and pull handle (C) to the fully-open position.
14. Clean the receptacle mating surfaces.

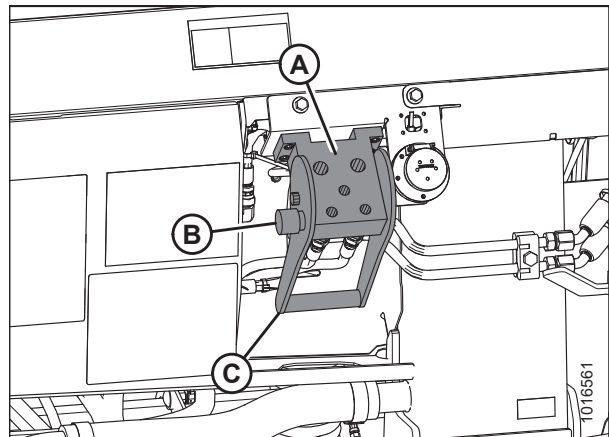

Figure 5.33: Float Module Receptacle

15. Remove hydraulic quick coupler (A) from the combine, and clean the mating surfaces.



Figure 5.34: Combine Connectors

## ATTACHING HEADER TO COMBINE

16. Position the coupler onto coupler receptacle (A) and push handle (B) (not shown) to engage the multicoupler pins into the receptacle.
17. Push handle (B) to the closed position until lock button (C) snaps out.

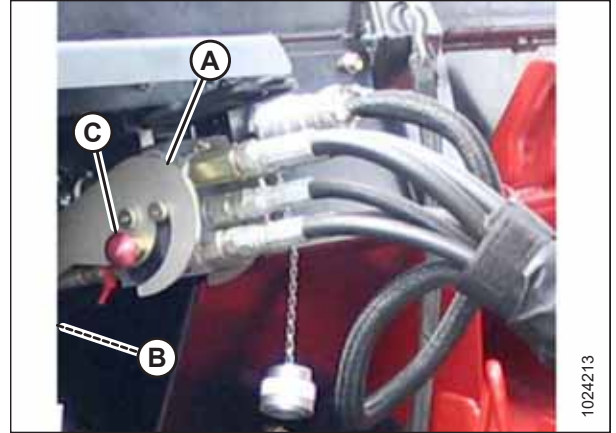

Figure 5.35: Hydraulic Connection

18. Remove the cover from electrical receptacle (A). Ensure the receptacle is clean and has no signs of damage.

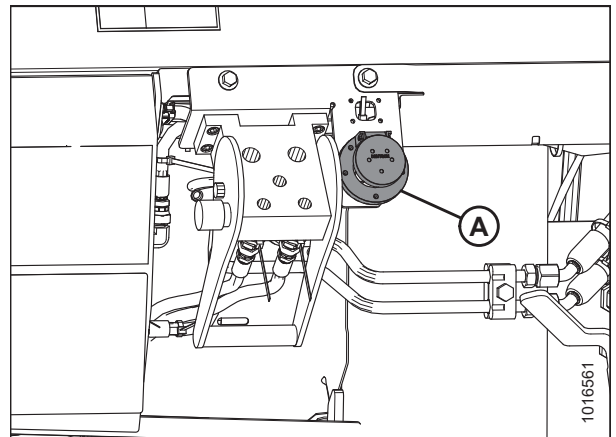

Figure 5.36: Electrical Receptacle

19. Remove electrical connector (A) from the storage cup on the combine and route it to the float module receptacle.



Figure 5.37: Combine Connectors

## ATTACHING HEADER TO COMBINE

20. Align the lugs on connector (A) with the slots in receptacle (B), push the connector onto the receptacle, and turn the collar on the connector to lock it in place.

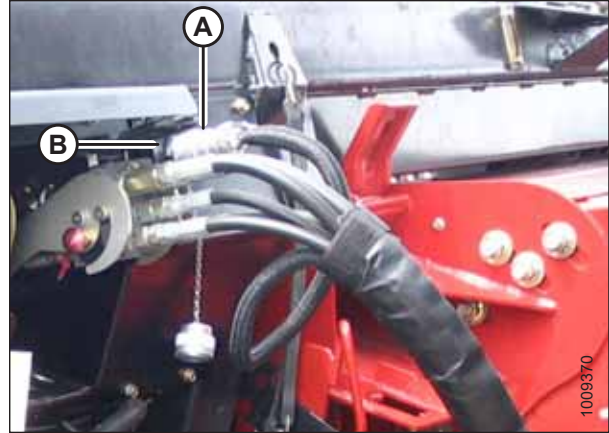

Figure 5.38: Electrical Connection

21. Detach safety chain (C) from support bracket (B).
22. Pull collar (D) back to release driveline (A) from support bracket.

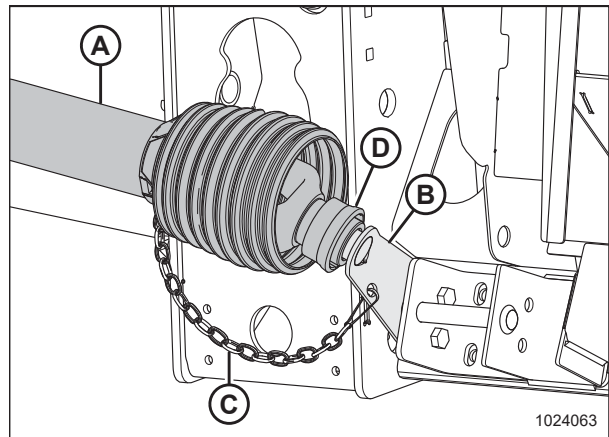

Figure 5.39: Driveline in Storage Position

23. Pull back collar (A) on the end of the driveline, and push the driveline onto combine output shaft (B) until the collar locks.

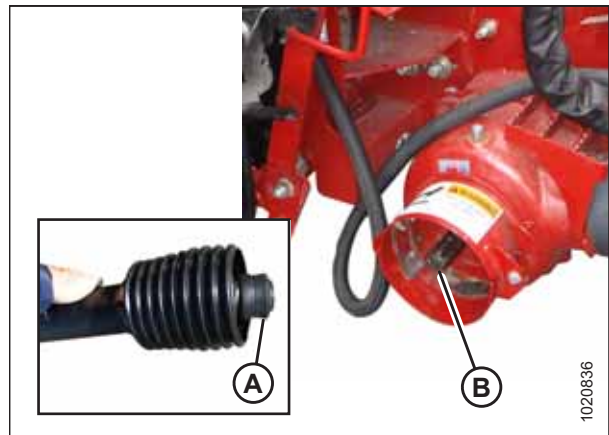

Figure 5.40: Combine Output Shaft

## ATTACHING HEADER TO COMBINE

24. Disengage the float locks by pulling each float lock handle (A) away from the float module and setting it in unlocked position (B).

**NOTE:**

Illustration at right shows the right side of the header. Float lock on left side of header opposite.

25. Proceed to [5.7 Completing Header Assembly, page 126](#).

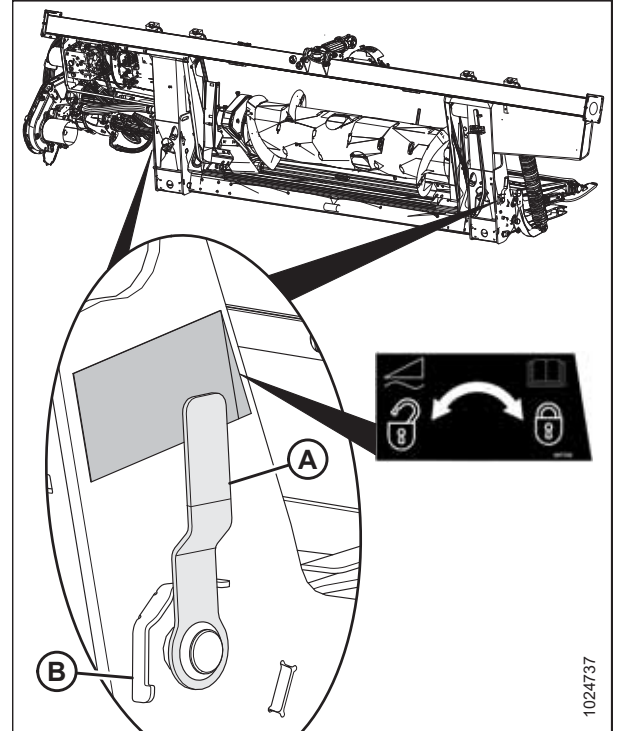

Figure 5.41: Float Lock Handle

### 5.3.2 Enabling Reel Fore-Aft / Header Tilt – Case IH 250 Series

This topic is for enabling the reel fore aft / header tilt on Case IH 250 Series combines that are equipped with optional the feeder fore/aft face plate control.

**NOTE:**

Changes may have been made to the combine controls or display since this document was published. Refer to the combine operator's manual for updates.

1. On the main page of the combine display, select Toolbox (A). The TOOLBOX page opens.

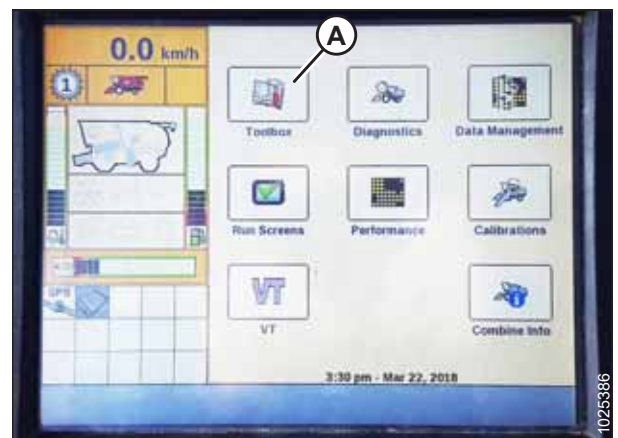

Figure 5.42: Case IH Combine Display

## ATTACHING HEADER TO COMBINE

2. Using arrow key (A), find the Head 2 page and select it.
3. Locate Shift + Reel Fore/aft heading (B).
4. From drop down menu (C), select Header Features.



Figure 5.43: Case IH Combine Display



## 5.4 John Deere Combines

The FD1 Series FlexDraper® Header is compatible with John Deere 60, 70, S, and T Series combines.

### 5.4.1 Attaching Header to John Deere Combine

#### WARNING

To avoid injury or death from unexpected start-up of machine, always stop the engine and remove the key from the ignition before leaving the operator's seat for any reason.

1. Shut down the engine, and remove the key from the ignition.
2. Push handle (A) on the combine multicoupler receptacle towards the feeder house to retract pins (B) at the bottom corners of the feeder house. Clean the receptacle.

#### WARNING

Never start or move the machine until you are sure all bystanders have cleared the area.

3. Start the engine and slowly drive the combine up to the header until feeder house saddle (C) is directly under float module top cross member (D).
4. Raise the feeder house slightly to lift the header ensuring the feeder house saddle is properly engaged in the float module frame.
5. Shut down the engine, and remove the key from the ignition.
6. Pull handle (A) on the float module to release multicoupler (B) from the storage position. Remove the multicoupler, and push the handle back into the float module to store.

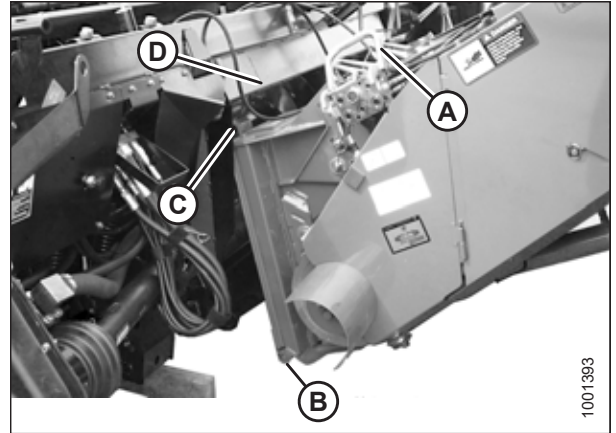

Figure 5.44: Combine and Float Module

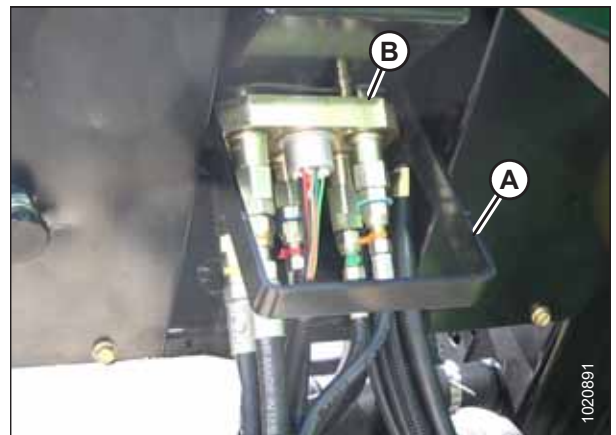

Figure 5.45: Multicoupler Storage

## ATTACHING HEADER TO COMBINE

7. Position multicoupler (A) onto the receptacle, and pull handle (B) to engage the lugs on the multicoupler into the handle.
8. Pull handle (B) to a horizontal position and ensure multicoupler (A) is fully engaged into the receptacle.

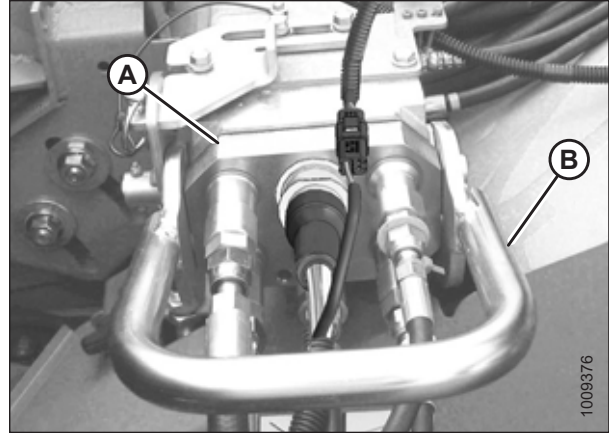

Figure 5.46: Multicoupler

9. Ensure that both feeder house pins (A) are fully engaged into the float module brackets.

**NOTE:**

If pins (A) do not fully engage the float module brackets, loosen bolts (B) and adjust the bracket as required.

10. Tighten bolts (B).

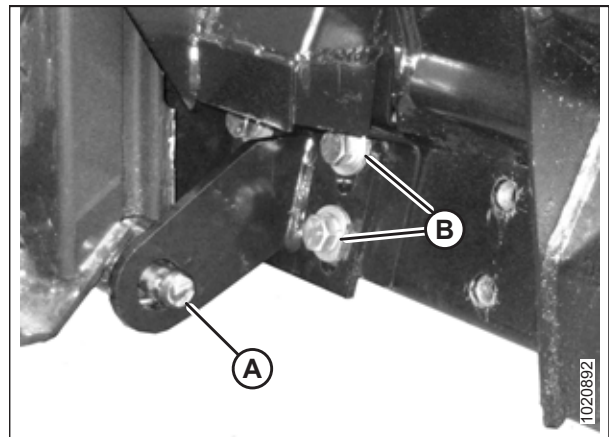

Figure 5.47: Feeder House Pin

11. Slide latch (A) to lock handle (B) in position and secure with lynch pin (C).
12. If the float module is equipped with the reel fore-aft/header tilt selector, connect harness (D) to combine connector (E).

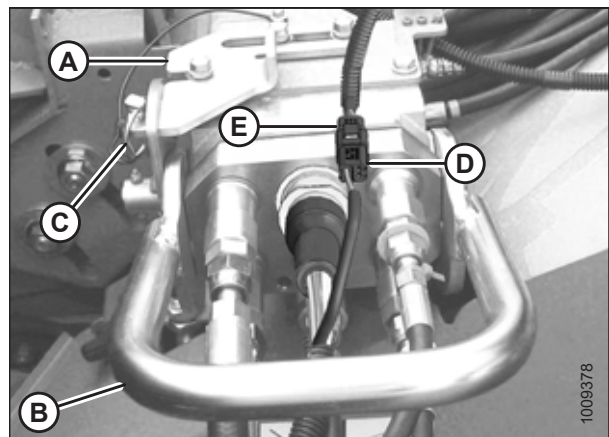

Figure 5.48: Multicoupler

## ATTACHING HEADER TO COMBINE

13. Detach safety chain (C) from support bracket (B).
14. Pull collar (D) back to release driveline (A) from support bracket.

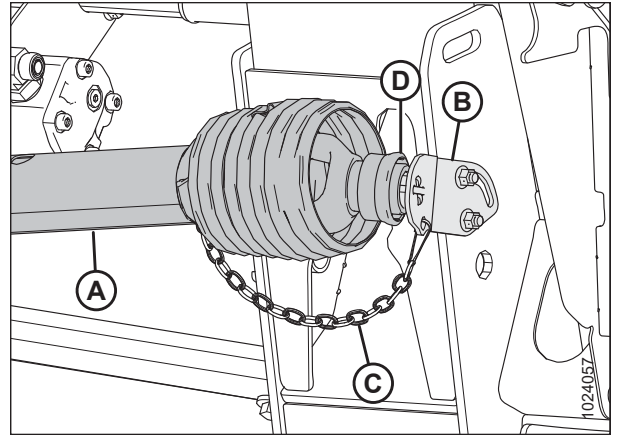

Figure 5.49: Driveline

15. Pull back collar (A) on the end of the driveline, and push the driveline onto combine output shaft (B) until the collar locks.

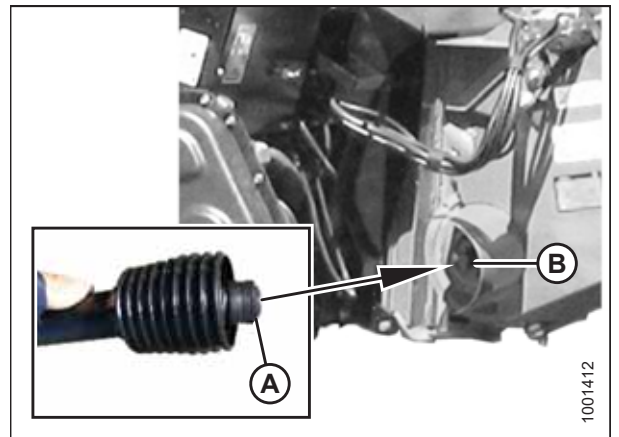

Figure 5.50: Driveline

## ATTACHING HEADER TO COMBINE

16. Disengage the float locks by pulling each float lock handle (A) away from the float module, and setting it in unlocked position (B).

**NOTE:**

Illustration at right shows the right side of the header. Float lock on left side of header opposite.

17. Proceed to [5.7 Completing Header Assembly, page 126](#).

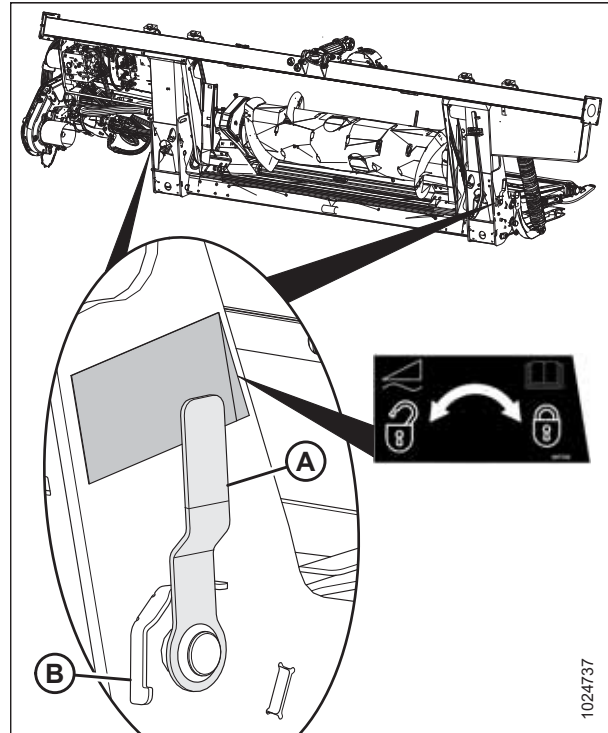

Figure 5.51: Float Lock Handle

### 5.4.2 Installing Reel Fore-Aft / Header Tilt Switch – S and T Series Combines

The reel fore-aft/header tilt switch allows the combine Operator to select either reel FORE-AFT or HEADER TILT mode.

**! WARNING**

To avoid injury or death from unexpected start-up of machine, always stop the engine and remove the key from the ignition before leaving the operator's seat for any reason.

This procedure is applicable to John Deere S and T Series combines. For John Deere 60 or 70 Series combines, refer to [5.4.3 Installing Reel Fore-Aft / Header Tilt Switch – 60 and 70 Series Combines, page 111](#).

Prepare the combine cab for switch and harness installation as follows:

1. Lower and tilt the combine feeder house all the way forward if equipped. This will ensure that the electrical harnesses will be installed with sufficient slack.
2. Shut down the engine, and remove the key from the ignition.
3. Disconnect the negative cable from the combine battery. For instructions, refer to the combine manual.

**IMPORTANT:**

If you do not disconnect the battery before connecting the cab draper control harness to the combine's auxiliary power connectors, electrical components may be damaged.

## ATTACHING HEADER TO COMBINE

4. At the multicoupler, connect the cab draper extension harness (MD #304211) to the float module as follows:
  - **Connector C3A** – If the In-Cab Side Draper Speed Control kit has been installed, plug connector C3B on the valve drive harness into connector C3A. If the In-Cab Side Draper Speed Control kit has not been installed, leave C3A unconnected.
  - **Connector C5B** – Plug connector C5B (A) into connector C5A on the JD completion harness.

**NOTE:**

Connectors C3A and C5B are shipped with caps. The caps need to be removed in order to connect these connectors.

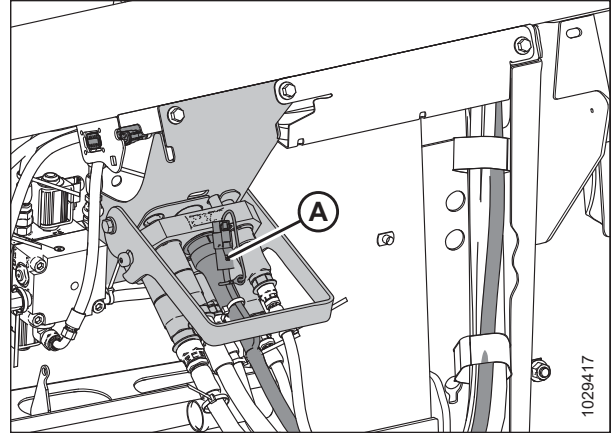

Figure 5.52: Multicoupler on Float Module

5. Route cab draper extension harness (A) along the left side of the combine feeder house, under shield (B), to the underside of the combine cab (along the existing hoses).

**NOTE:**

The illustration shows an S6, S7, T6, or T7 Series combine. Earlier models may look different.

6. Secure cab draper extension harness (A) to the hoses with cable ties (MD #16661) as required.

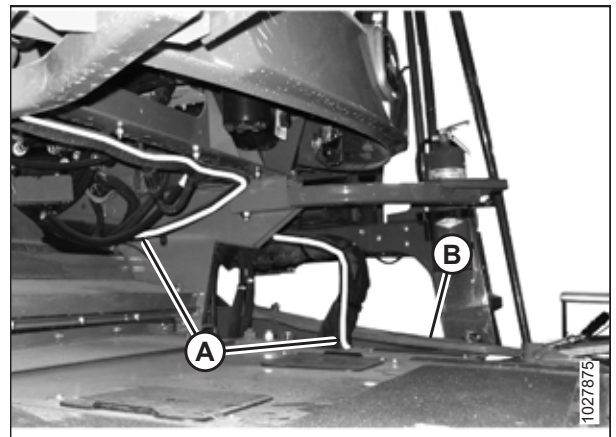

Figure 5.53: Harness Routing

7. Inside the cab, lift floor mat (A) at the front right corner to access knockout (B).

**NOTE:**

The illustration shows an S6, S7, T6, or T7 Series combine. Earlier models may look different.

8. Remove knockout (B).

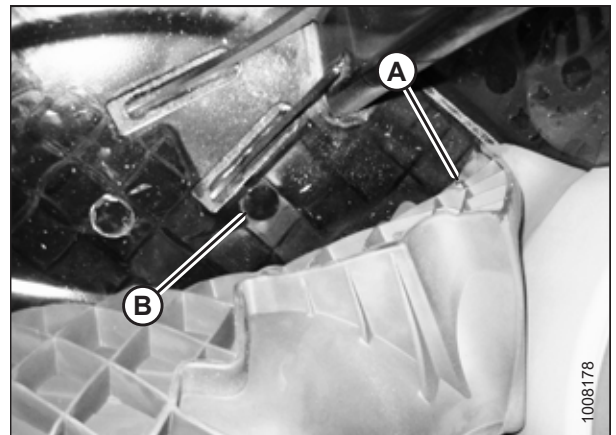

Figure 5.54: Floor Mat at Forward Right Corner and Knockout

## ATTACHING HEADER TO COMBINE

- Pull the ends of cab draper extension harness (A) up into the cab through hole (B).

### NOTE:

The illustration shows an S6, S7, T6, or T7 Series combine. Earlier models may look different.

- Connect cab draper extension harness (A) to cab draper control harness (C) (MD #304210) as follows:
  - Plug C4B into C4A.
  - Plug C6B into C6A.

- Reinstall floor mat.

### NOTE:

Any extra wire can be placed between the floor mat and the right console at the cup holder.

- For S6 Series, T6 Series, and earlier combines:** In the combine cab, open the storage compartment on the console.
- For S6 Series, T6 Series, and earlier combines:** Remove two screws (A) attaching compartment cover (B) to the console and then remove the cover.

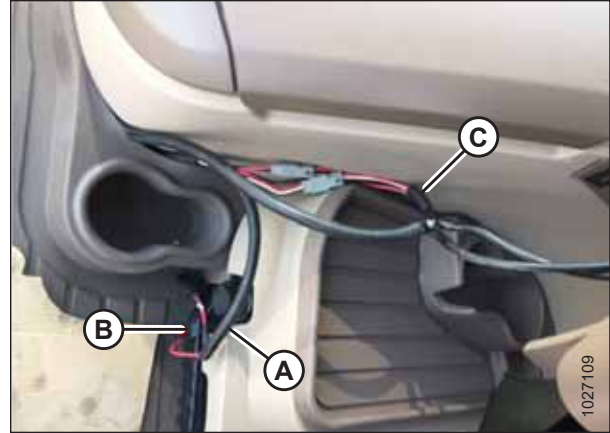

Figure 5.55: Harness Connections

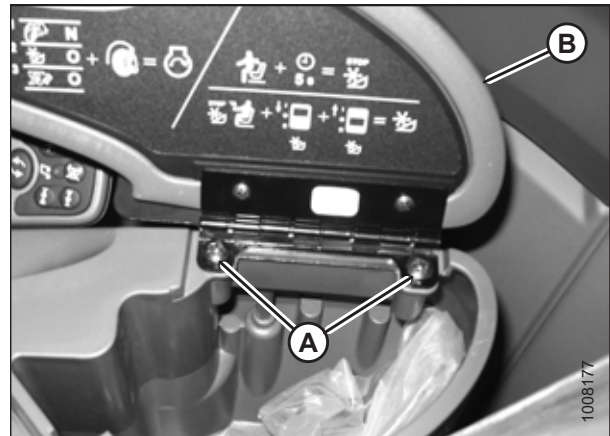

Figure 5.56: Storage Compartment and Cover

- For S6 Series, T6 Series, and earlier combines:** Two rocker switch supports are provided: MD #158377 (A) and MD #220734 (B). Select the one you need to use:
  - MD #158377 – Used on John Deere 60 and 70 Series combines
  - MD #220734 – Used on John Deere S and T Series combines

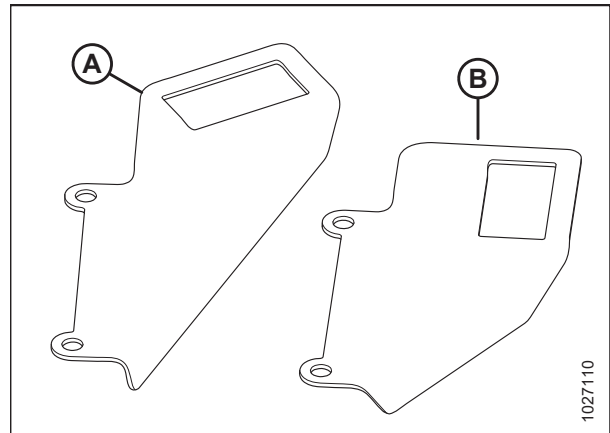

Figure 5.57: Rocker Switch Supports

## ATTACHING HEADER TO COMBINE

15. **For S7 and T7 Series combines only:** Secure rocker switch support (A) (MD #220734) to tilt/draper speed support (B) (MD #304111) with two M6 hex socket head screws (C) (MD #136886) and two M6 hex flange lock nuts (MD #152668).

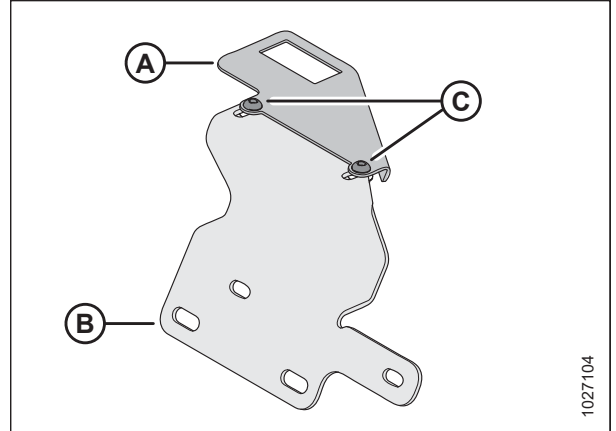

Figure 5.58: Supports for S7 and T7 Series Combines

16. Install rocker switch (A) (MD #109064) into rocker switch support (C) from the top. Ensure the lugs on the underside of the support have secured the switch.

**NOTE:**

The tilt/draper speed support needed for S7 and T7 Series combines is not shown in the illustration.

17. One branch of cab draper control harness (B) ends in two terminals: T242 and T243. Connect one terminal to the center terminal on rocker switch (A) and the other to either outer terminal. The color of the wires does not matter.

For more information, refer to [Figure 5.60, page 108](#).

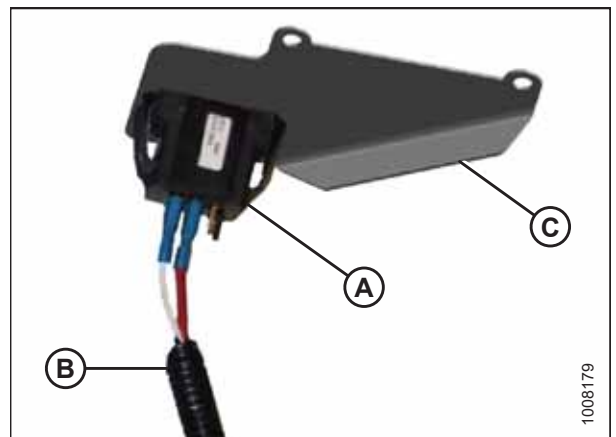

Figure 5.59: Switch and Harness

## ATTACHING HEADER TO COMBINE

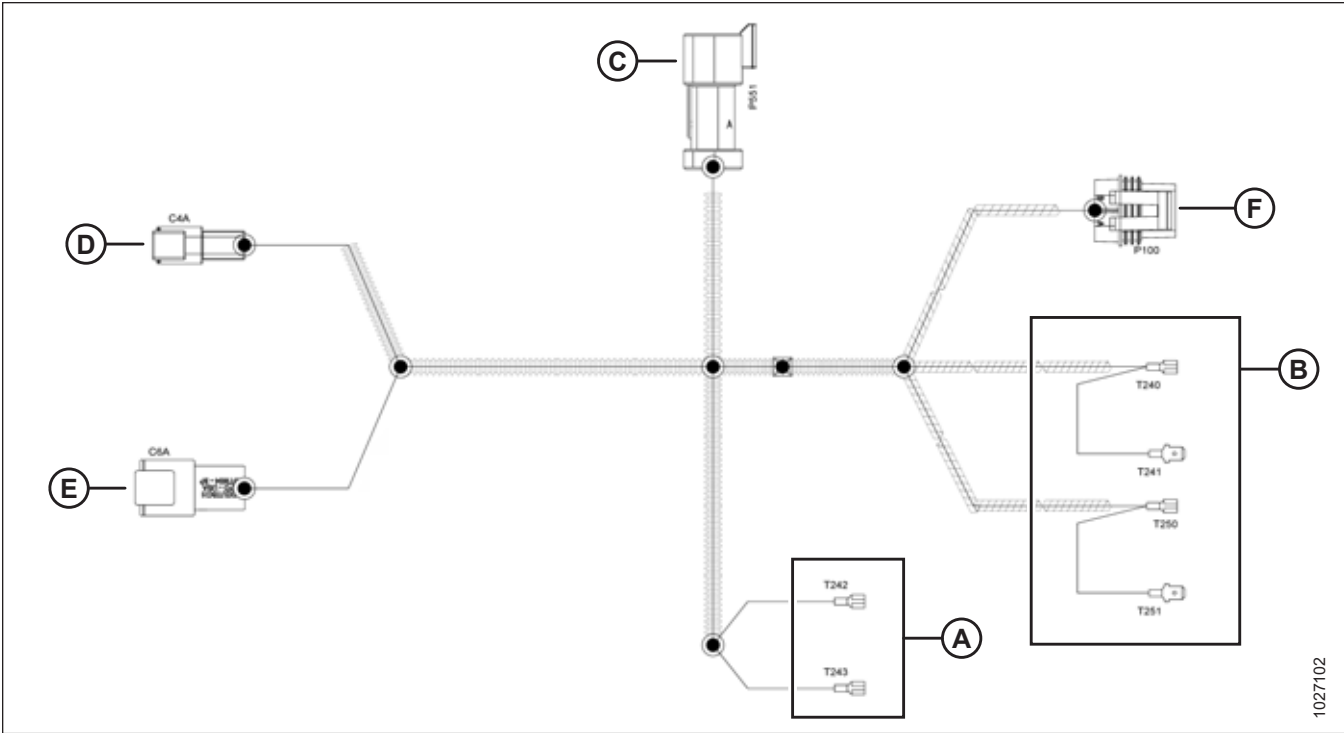

Figure 5.60: Cab Draper Control Harness (MD #304210)

A - Terminals Connect to Rocker Switch

B - Terminals Connect to Auxiliary Power Outlet Strip

C - P551 Connects to Speed Control Rheostat

D - C4A Connects to C4B on Harness (MD #304211)

E - C6A Connects to C6B on Harness (MD #304211)

F - P100 – Inline Fuse

18. If the In-Cab Side Draper Speed Control kit has been installed, connect connector P551 to the speed control rheostat. If the In-Cab Side Draper Speed Control kit has not been installed, leave connector P551 unconnected.

19. **S6 and T6 Series combines only:** Position rocker switch support (C) onto console and align the holes in the support with the holes in the console.

20. **S6 and T6 Series combines only:** Reinstall cover (B) and secure in place with existing screws (A).

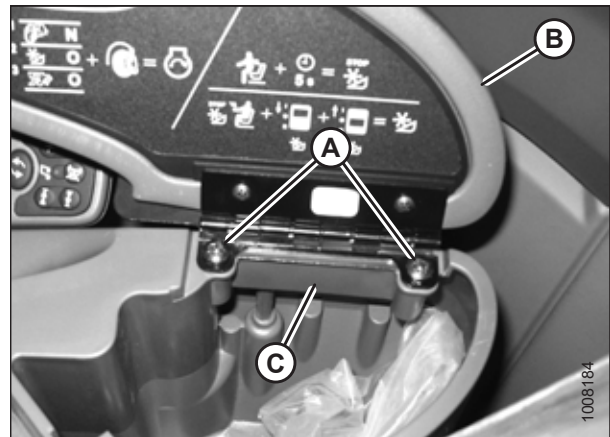

Figure 5.61: Support Position on Console – S6 and T6 Series Combines



## ATTACHING HEADER TO COMBINE

21. **S6 and T6 Series combines only:** Close cover and ensure that rocker switch (A) and rocker switch support (B) are secure.

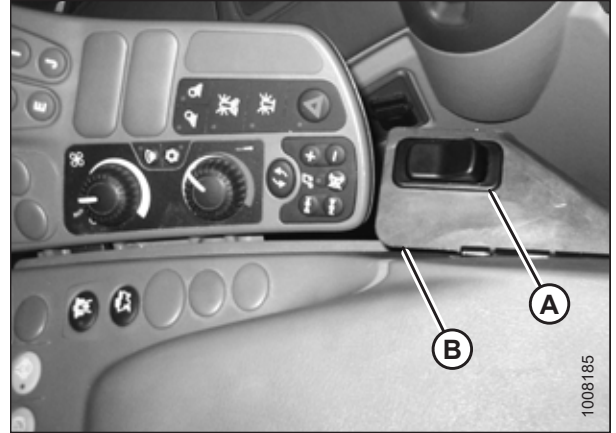

Figure 5.62: Secured Switch – S6 and T6 Series Combines

22. Remove two M6 countersunk head screws (C) securing track (B) to the side of the seat, then remove the track. Install tilt/draper speed support (A) between track (B) and the side of the seat using the M6 screws (C).

**NOTE:**

If other options are not being installed on the track, refer to the alternative installation location instructions below. The preferred installation location provides better access to the cup holders.

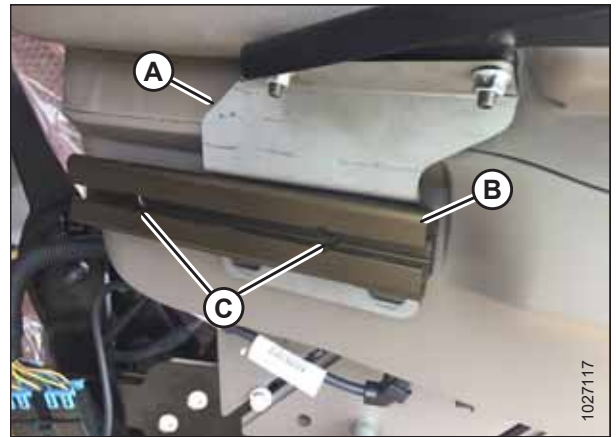

Figure 5.63: Side View of Seat with Supports Installed in Preferred Location

**NOTE:**

The rocker switch is not shown in the illustration at right.



Figure 5.64: Top View of Armrest Showing Supports Installed in Preferred Location

A - Tilt/Draper Speed Support

B - Rocker Switch Support

## ATTACHING HEADER TO COMBINE

23. **S7 and T7 Series combines only – alternative installation location:** Secure tilt/draper speed support (A) to track (B) with two M8 carriage head bolts (C) (MD #197171) and two M8 hex flange lock nuts (MD #135337).

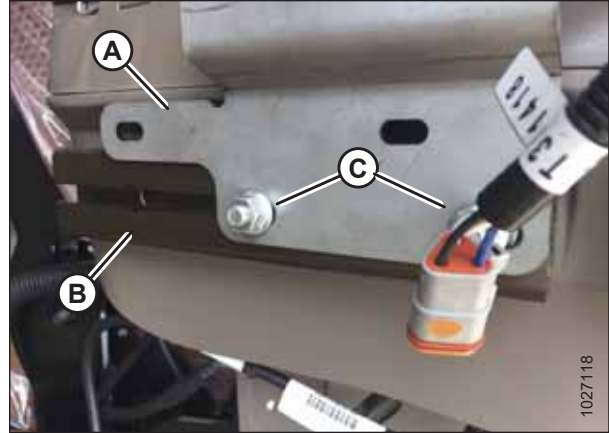

Figure 5.65: Side View of Seat with Supports Installed in Alternative Location

### NOTE:

The rocker switch is not shown in the illustration at right.

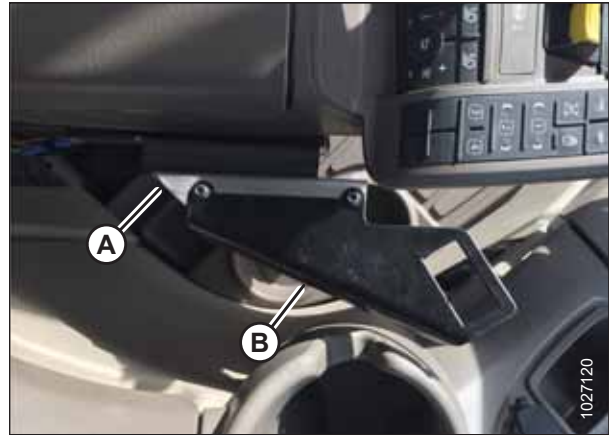

Figure 5.66: Top View of Armrest Showing Supports Installed in Alternative Location

A - Tilt/Draper Speed Support      B - Rocker Switch Support

## ATTACHING HEADER TO COMBINE

24. Connect the feed end of the cab draper control harness ([B] in Figure 5.60, page 108) to the auxiliary power outlet strip as follows:

**NOTE:**

The auxiliary power strip is on the right side of the cab floor on S6, S7, T6, and T7 Series combines, and near the window on earlier models.

- Terminals T240 and T241 are for power. Connect them to switched power supply (C).
- Terminals T250 and T251 are for ground. Connect them to ground (B).

**NOTE:**

Each circuit has a male and female terminal pair so that they can be connected in line with an existing circuit on the combine. They can also be connected to a spare circuit in the combine (at location [A]), which would only use one terminal out of each pair. Insulate any unused terminals with electrical tape.

**NOTE:**

The illustration shows an S6, S7, T6, or T7 Series combine. Earlier models may look different.

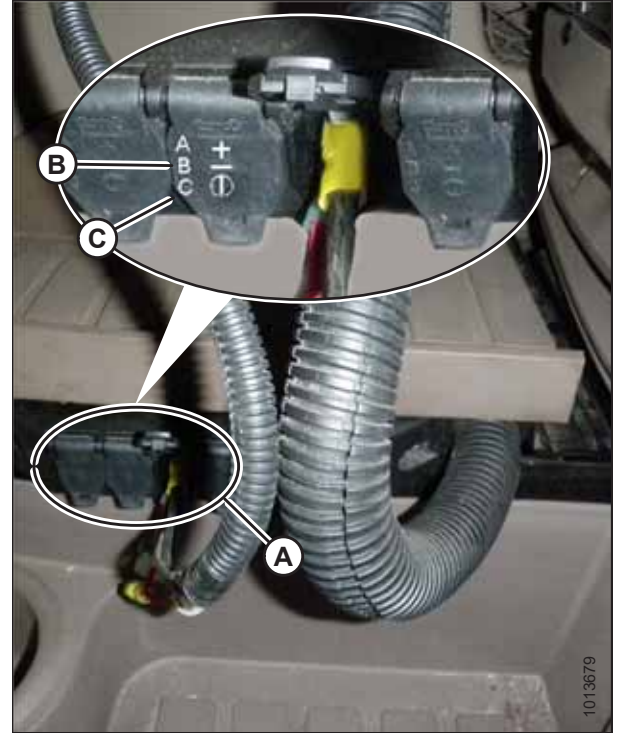

Figure 5.67: Combine Auxiliary Power Supply

25. Tape any unused terminals to the harness.
26. Reconnect the battery.

### 5.4.3 Installing Reel Fore-Aft / Header Tilt Switch – 60 and 70 Series Combines

The reel fore-aft/header tilt switch allows the combine Operator to select either reel FORE-AFT or HEADER TILT mode.

#### **WARNING**

To avoid injury or death from unexpected start-up of machine, always stop the engine and remove the key from the ignition before leaving the operator's seat for any reason.

This procedure applies to John Deere 60 and 70 Series combines. For John Deere S and T Series combines, refer to [5.4.2 Installing Reel Fore-Aft / Header Tilt Switch – S and T Series Combines, page 104](#).

1. Lower and tilt the combine feeder house all the way forward if equipped. This will ensure that the electrical harnesses will be installed with sufficient slack.
2. Shut down the engine, and remove the key from the ignition.
3. Disconnect the negative cable from the combine battery. For instructions, refer to the combine manual.

**IMPORTANT:**

If you do not disconnect the battery before connecting the cab draper control harness to the combine's auxiliary power connectors, electrical components may be damaged.

4. To ensure the switch harness will attach to selector valve wiring harness (with header tilted forward) and that the feeder house can be fully lowered with adequate slack in the harness, lay the switch harness along the route from the front of the feeder house to the auxiliary power supply in the cab.

## ATTACHING HEADER TO COMBINE

- Route switch harness (A) through existing grommet (B) on the combine's electrical plate (located at the rear of the right side window).

**NOTE:**

To simplify feeding the harness through the grommet, wrap the switch and power plugs with electrical tape.

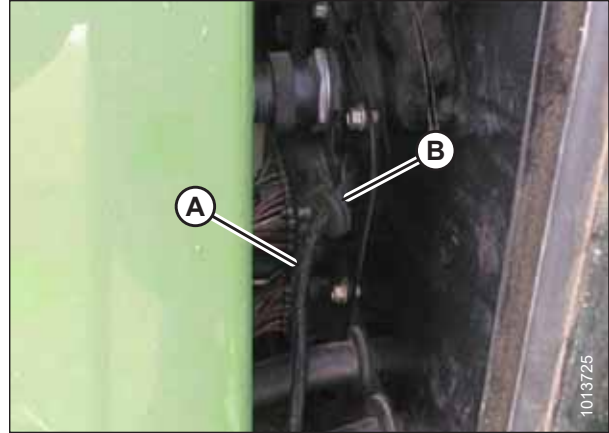

Figure 5.68: Switch Harness Routing

- Retrieve switch (A) and support (C) provided with kit.
- Install switch (A) into support (C) from the top. Ensure lugs on underside of support have secured the switch.

**NOTE:**

Image at right shows switch (A) connected to harness (B).

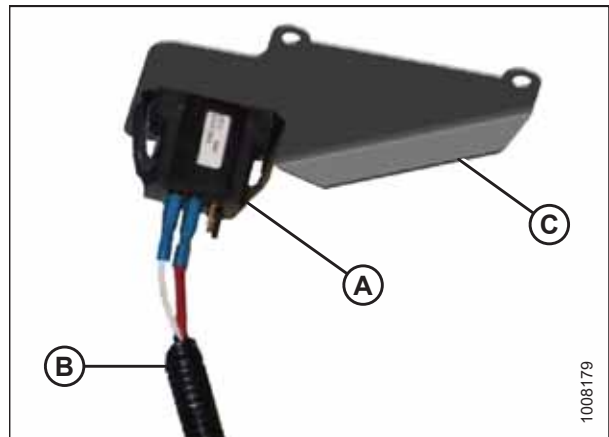

Figure 5.69: Switch and Harness

- Mount switch plate (A) between the armrest cover hinge and the armrest using existing screws (B).

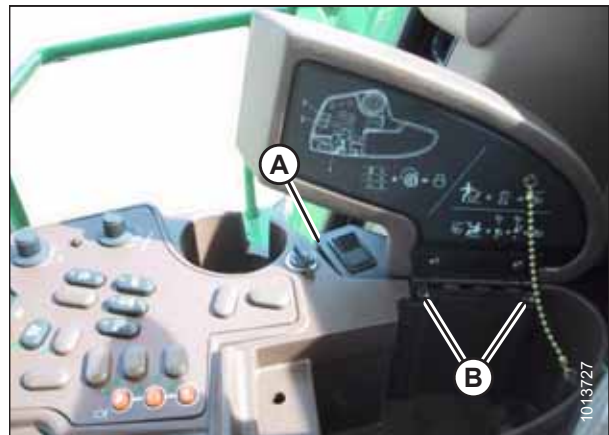

Figure 5.70: Switch Plate Mounting

## ATTACHING HEADER TO COMBINE

9. Connect the switch end of harness (A) to switch (B) with one of the wires to center terminal and the other wire to either outer terminal.

**NOTE:**

The color of the wires does not matter; ensure one wire terminates at the center terminal.

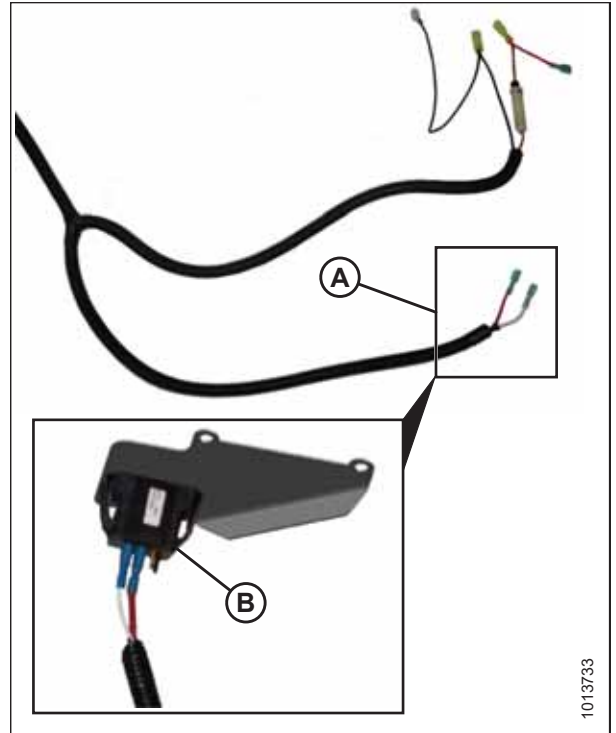

Figure 5.71: Switch End of Harness and Switch

10. Connect the switch harness to auxiliary power supply (D). Connect the wire with the in-line fuse to switched power supply (C) and the second wire to ground (B).

**IMPORTANT:**

Connecting the draper control harness to an unswitched power supply or cigarette lighter (using harness MD #220570, provided in the kit) will supply constant power to the header tilt side of the solenoid valve and drain the combine battery during extended shutdown periods.

11. Tape the unused wire jumpers to the harness.

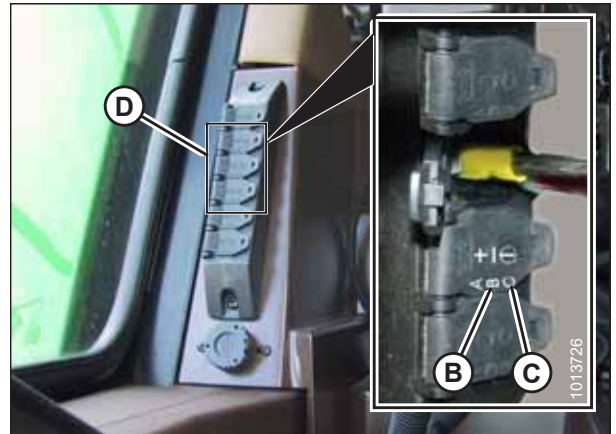

Figure 5.72: Auxiliary Power Supply

## ATTACHING HEADER TO COMBINE

12. Route switch harness (A) across the underside of the cab, alongside an existing harness, to the left side of the feeder house.

### IMPORTANT:

To prevent damage to harness, ensure adequate slack by lowering the feeder house fully before securing harness with cable ties.

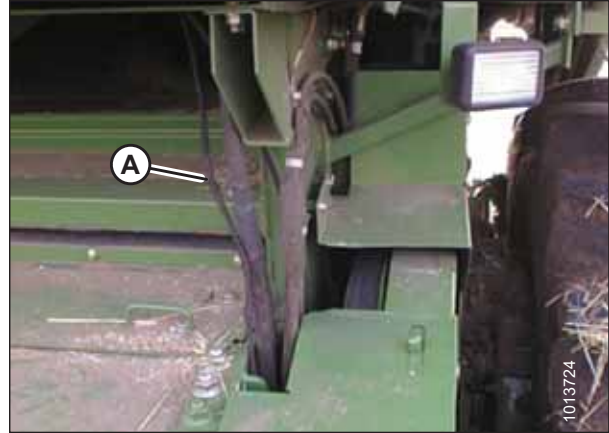

Figure 5.73: Switch Harness Routing

13. Secure switch harness (A) at the rear of the feeder house with cable tie.



Figure 5.74: Switch Harness Routing

14. Route switch harness (A) through the welded hose guide on feeder house.



Figure 5.75: 60/70 Series Harness Routing

## ATTACHING HEADER TO COMBINE

15. Secure switch harness (A) at multicoupler with a cable tie. Leave 100 cm (40 in.) extending past location (B).

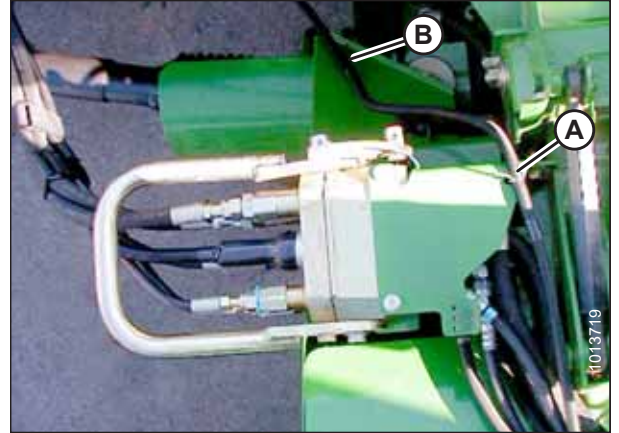

Figure 5.76: Switch Harness Routing

## 5.5 CLAAS Combines

The FD1 Series FlexDraper® Header is compatible with CLAAS 500, 600, and 700 series, Tucano, and 7000, 8000 series combines.

**NOTE:**

Older Tucano combines (model year 2006 and prior) are incompatible with FD1 Series FlexDraper® Headers.

### 5.5.1 Attaching Header to CLAAS Combine

**⚠ WARNING**

To avoid injury or death from unexpected start-up of machine, always stop the engine and remove the key from the ignition before leaving the operator's seat for any reason.

1. Shut down the engine, and remove the key from the ignition.
2. Move handle (A) on the float module into the raised position, and ensure pins (B) at the bottom corners of the float module are retracted.

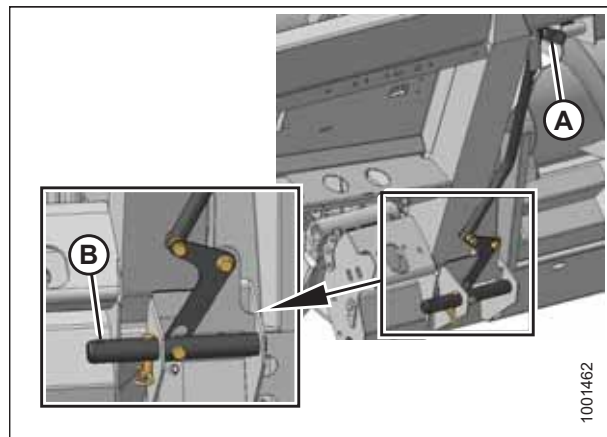

Figure 5.77: Pins Retracted

**⚠ WARNING**

Never start or move the machine until you are sure all bystanders have cleared the area.

3. Start the engine and slowly drive the combine up to the header until feeder house saddle (A) is directly under float module top cross member (B).
4. Raise the feeder house slightly to lift the header, ensuring the feeder saddle is properly engaged in the float module frame.
5. Shut down the engine, and remove the key from the ignition.

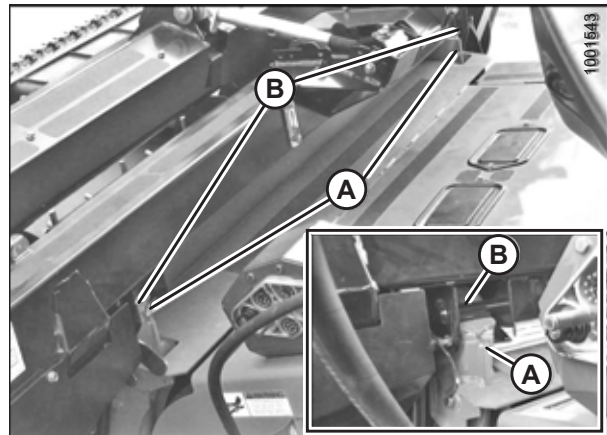

Figure 5.78: Header on Combine



## ATTACHING HEADER TO COMBINE

- Remove locking pin (B) from float module pin (A).

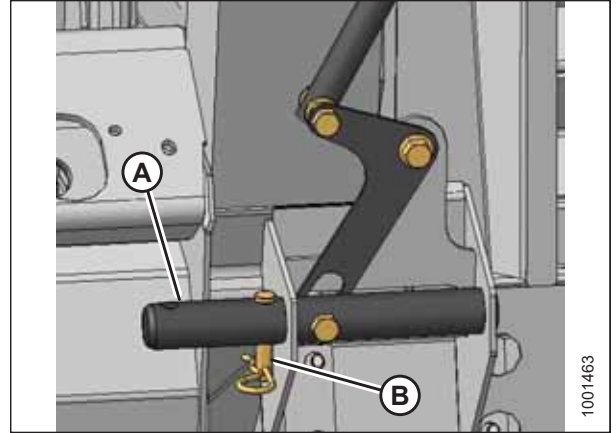

Figure 5.79: Locking Pins

- Lower handle (A) to engage float module pins (B) into the feeder house. Reinsert locking pin (C) and secure with the hairpin.
- Remove the blocks from under the cutterbar.



### WARNING

Never start or move the machine until you are sure all bystanders have cleared the area.

- Start the engine. For instructions, refer to the combine operator's manual.
- Lower the header fully.
- Shut down the engine, and remove the key from the ignition.
- Unscrew knob (A) on combine coupler (B) to release the coupler from the receptacle.
- Clean coupler (B) and receptacle.

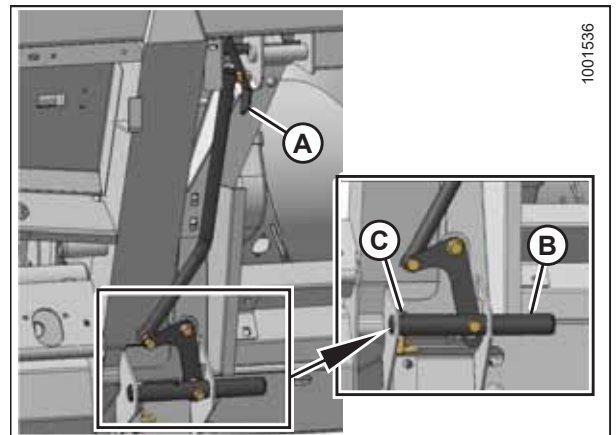

Figure 5.80: Engaging Pins

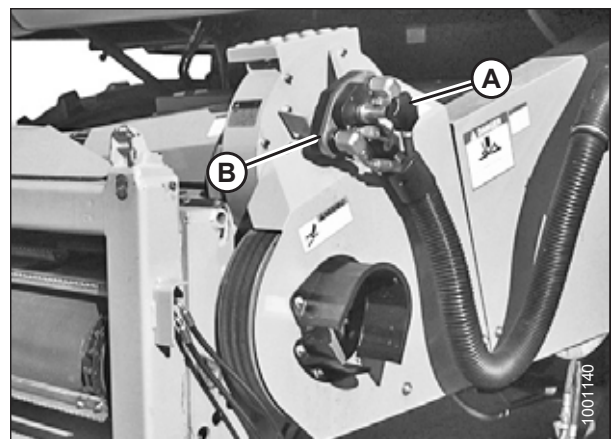

Figure 5.81: Combine Coupler

## ATTACHING HEADER TO COMBINE

14. Remove float module receptacle cover (A).

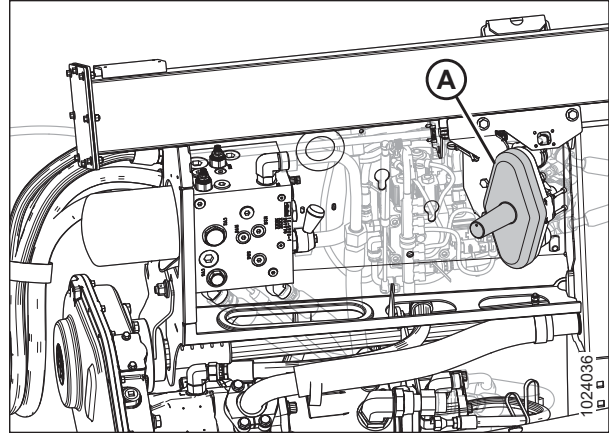

Figure 5.82: Receptacle Cover

15. Place float module receptacle cover (A) onto the combine receptacle.

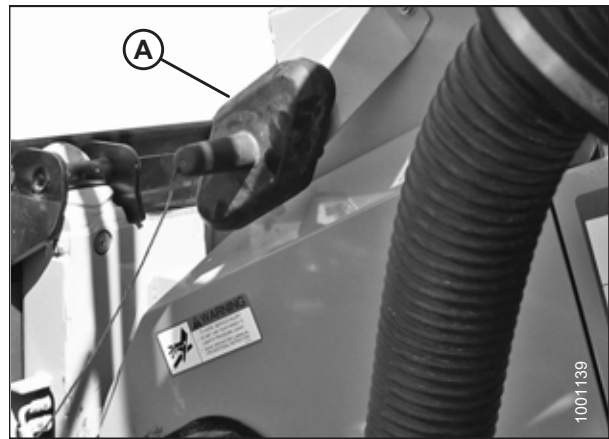

Figure 5.83: Receptacle Cover

16. Clean mating surface of coupler (A) and position onto float module receptacle (C).
17. Turn knob (B) to secure the coupler to the receptacle.

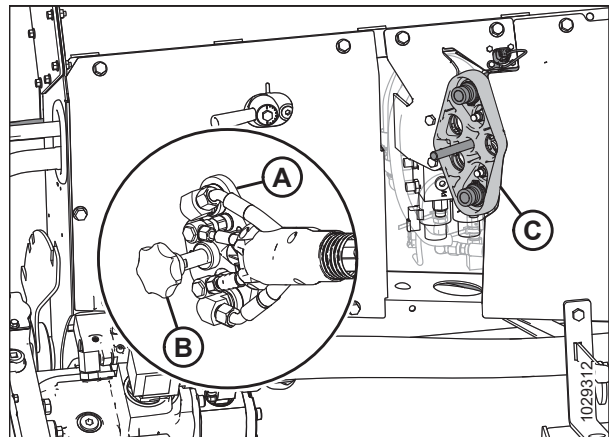

Figure 5.84: Coupler

## ATTACHING HEADER TO COMBINE

18. Detach safety chain (C) from support bracket (B).
19. Pull collar (D) back to release driveline (A) from support bracket. Remove the driveline from the support bracket.

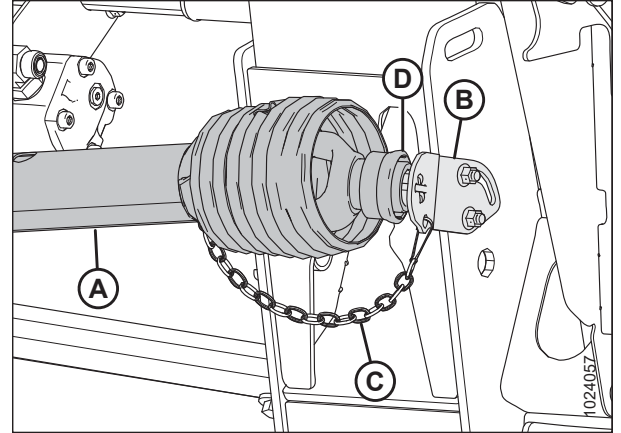

Figure 5.85: Driveline

20. Attach driveline (A) to the combine output shaft.

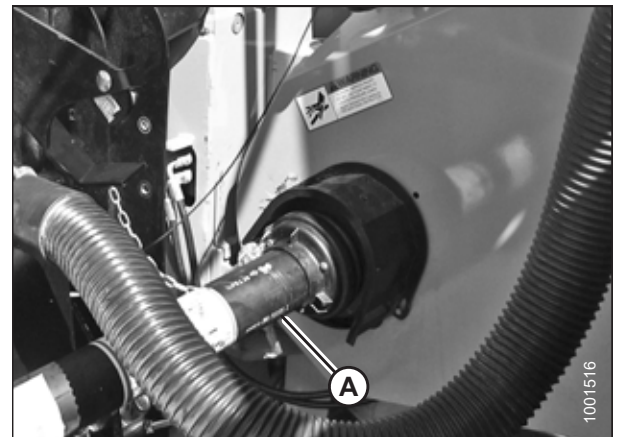

Figure 5.86: Driveline and Output Shaft

## ATTACHING HEADER TO COMBINE

21. Disengage both header float locks by pulling each float lock handle (A) away from the float module and setting it in unlocked position (B).

**NOTE:**

Illustration at right shows the right side of the header. Float lock on left side of header opposite.

22. Proceed to [5.7 Completing Header Assembly, page 126](#).

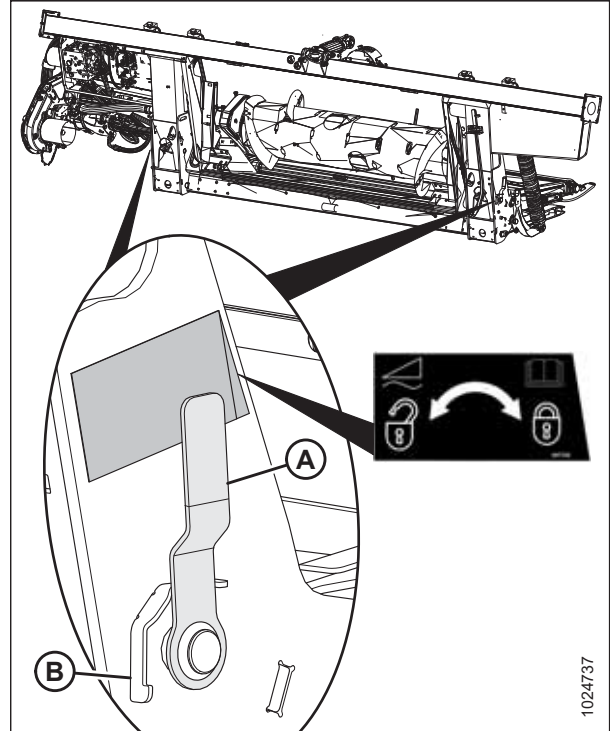

Figure 5.87: Float Lock Handle

## 5.6 New Holland Combines

The FD1 Series FlexDraper® Header is compatible with the following New Holland combines:

**Table 5.3 Header and Combine Compatibility**

Series	Combine Model
CR	920, 940, 960, 970, 980
	9020, 9040, 9060, 9065, 9070, 9080
	6090, 7090, 8080, 8090, 9090
	6.80, 6.90, 7.90, 8.90, 9.90, 10.90
CX	840, 860, 870, 880
	8070, 8080, 8090
	8080 Elevation, 8090 Elevation

### 5.6.1 Attaching Header to New Holland CR/CX Combine

#### **WARNING**

To avoid injury or death from unexpected start-up of machine, always stop the engine and remove the key from the ignition before leaving the operator's seat for any reason.

1. Shut down the engine, and remove the key from the ignition.
2. On the upper left side of the combine float module, remove nut (A), washer, spring, and lever (B).

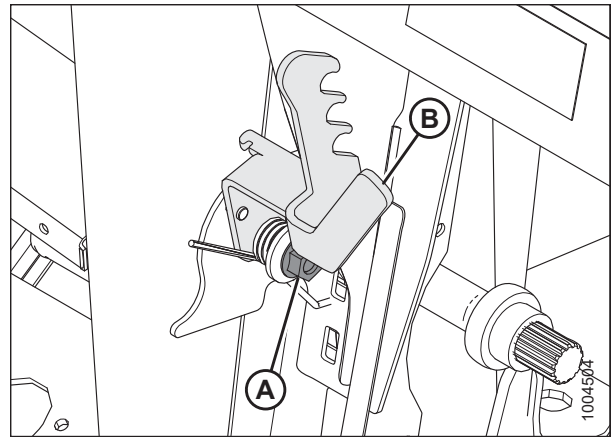

**Figure 5.88: Combine Float Module Upper Left Side**

## ATTACHING HEADER TO COMBINE

3. Position lever (A) onto stud (B).

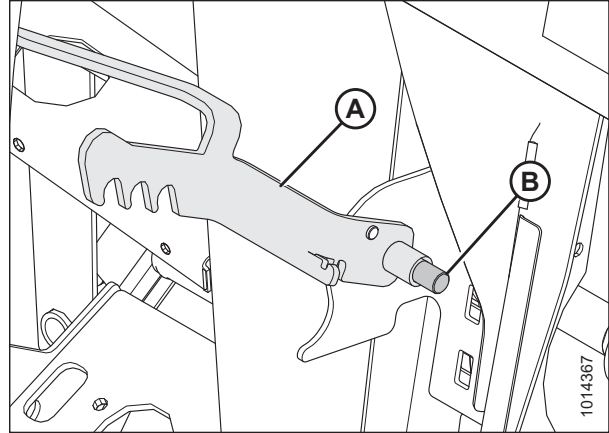

Figure 5.89: Combine Float Module Upper Left Side

4. Place spring arm (C) into hook on lever (B) to preload it, and tighten nut (A) with washer onto the combine float module.

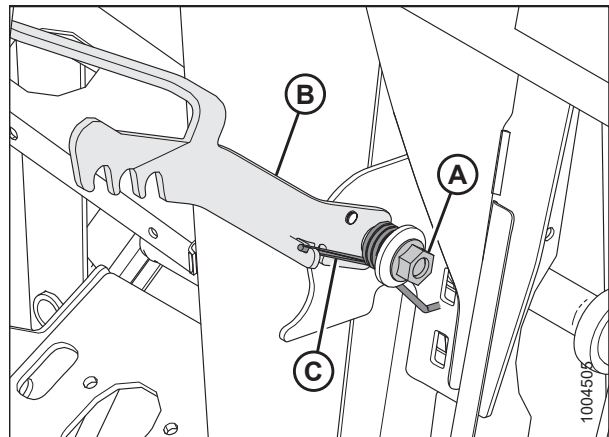

Figure 5.90: Combine Float Module Upper Left Side

5. Ensure handle (A) is positioned so hooks (B) can engage the float module.

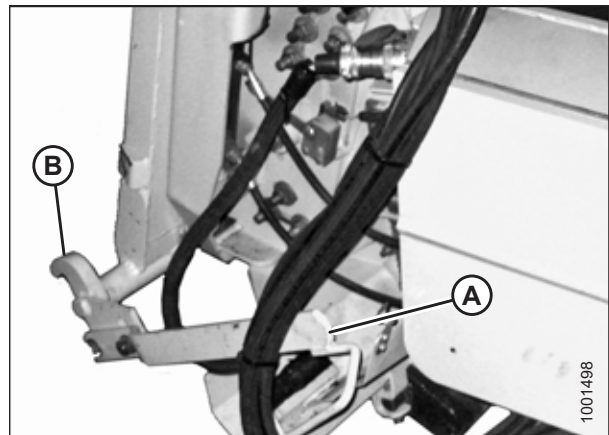

Figure 5.91: Feeder House Locks

## ATTACHING HEADER TO COMBINE

### **WARNING**

Never start or move the machine until you are sure all bystanders have cleared the area.

6. Start the engine and slowly drive the combine up to the float module until feeder house saddle (A) is directly under float module top cross member (B).
7. Raise the feeder house slightly to lift the header, ensuring the feeder saddle is properly engaged in the float module frame.
8. Shut down the engine, and remove the key from the ignition.
9. Lift lever (A) on the float module on the left side of the feeder house, and push handle (B) on the combine to engage locks (C) on both sides of the feeder house.
10. Push down on lever (A) so the slot in the lever engages the handle and locks the handle in place.
11. If the lock does not fully engage pin (D) on the float module when lever (A) and handle (B) are engaged, loosen bolts (E) and adjust lock (C). Retighten bolts.
12. Open the cover on receptacle (A) located on the left side of the float module.
13. Push in lock button (B) and pull handle (C) to the fully open position.
14. Clean the receptacle mating surfaces.

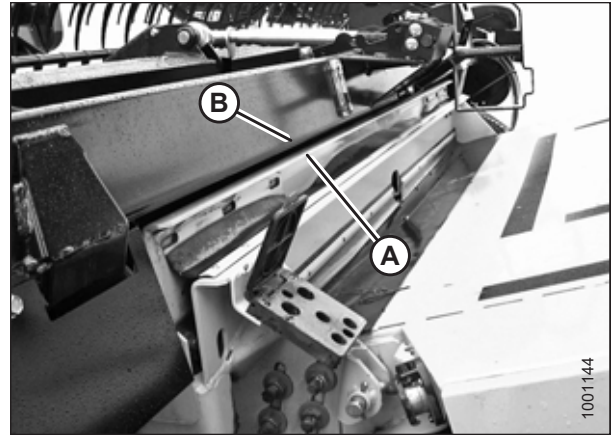

Figure 5.92: Header on Combine

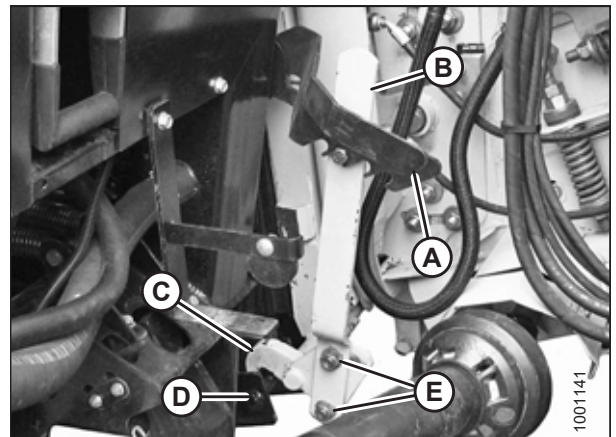

Figure 5.93: Feeder House Locks

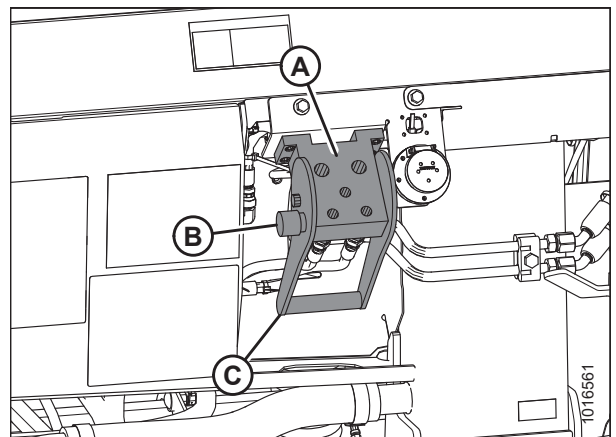

Figure 5.94: Float Module Receptacle

## ATTACHING HEADER TO COMBINE

15. Remove hydraulic quick coupler (A) from the storage plate on the combine, and clean the mating surface of the coupler.

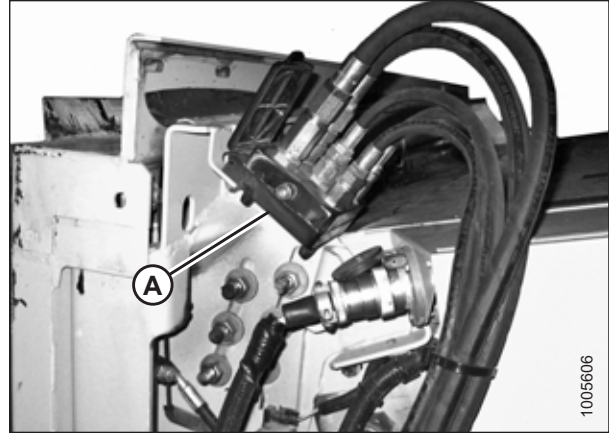

Figure 5.95: Combine Coupler

16. Position coupler (A) onto the float module receptacle, and push handle (B) to engage the pins into the receptacle.
17. Push handle (B) to closed position until lock button (C) snaps out.
18. Remove the cover on the float module electrical receptacle.
19. Remove connector (D) from the combine.
20. Align lugs on connector (D) with the slots in the float module receptacle, and push the connector onto the receptacle. Turn the collar on the connector to lock it in place.

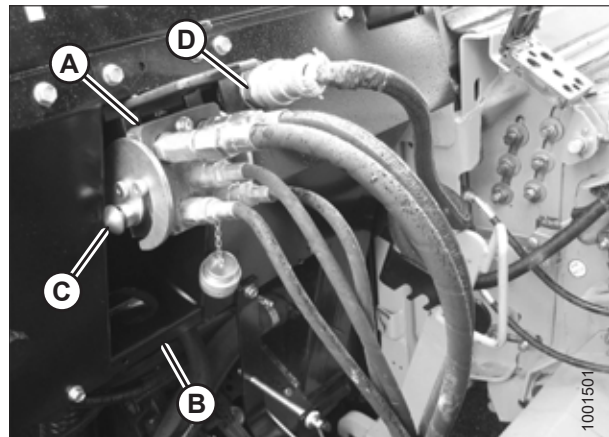

Figure 5.96: Connections

21. Detach safety chain (C) from support bracket (B).
22. Pull collar (D) back to release driveline (A) from support bracket. Remove the driveline from support bracket.

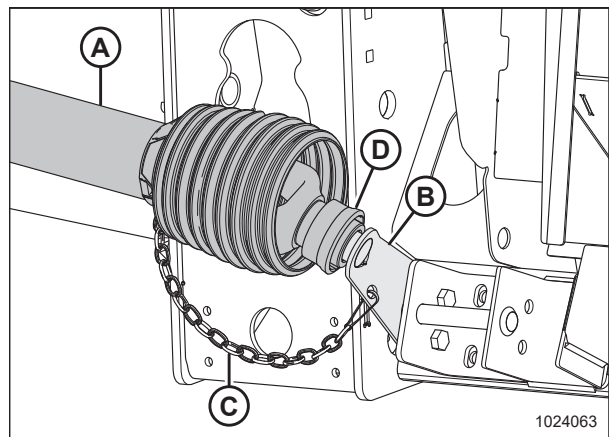

Figure 5.97: Driveline in Storage Position



## ATTACHING HEADER TO COMBINE

23. Pull back the collar on the end of the driveline, and push the driveline onto combine output shaft (A) until the collar locks.

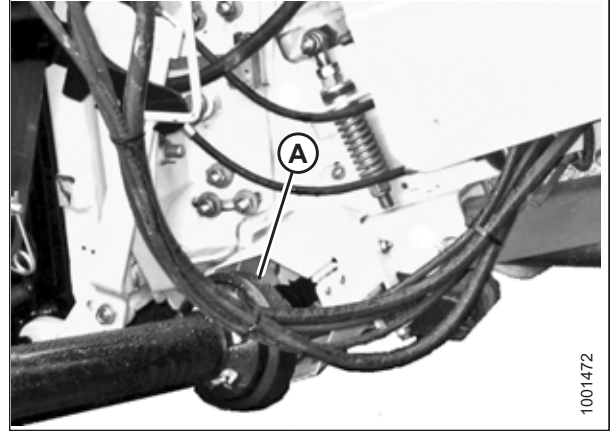

Figure 5.98: Driveline and Output Shaft

24. Disengage the float locks by pulling each float lock handle (A) away from the float module and setting it in unlocked position (B).

**NOTE:**

Illustration at right shows the right side of the header. Float lock on left side of header opposite.

25. Proceed to [5.7 Completing Header Assembly, page 126](#).

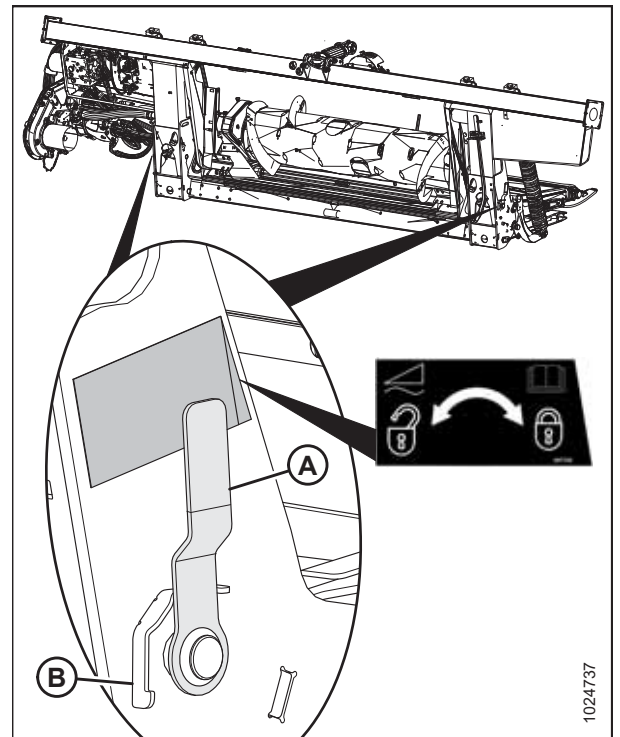

Figure 5.99: Float Lock Handle

## 5.7 Completing Header Assembly

### 5.7.1 Removing Shipping Supports

The removable supports are painted yellow. Refer to illustrations and remove the remaining supports as follows:

**NOTE:**

Unless otherwise specified, discard supports as well as all shipping material and hardware.

1. Remove two bolts (A) and remove strap (B) from both sides of center frame.

**NOTE:**

If strap is difficult to remove, lift on one end of header to release the load on the strap so that bolts can be removed.

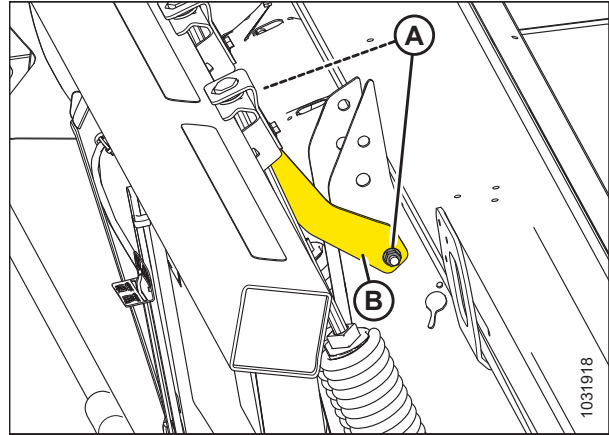

Figure 5.100: Strap on Center Frame

2. Remove lynch pin (A), nut and bolt (B), and remove shipping brace (C).
3. Reinstall lynch pin (A).

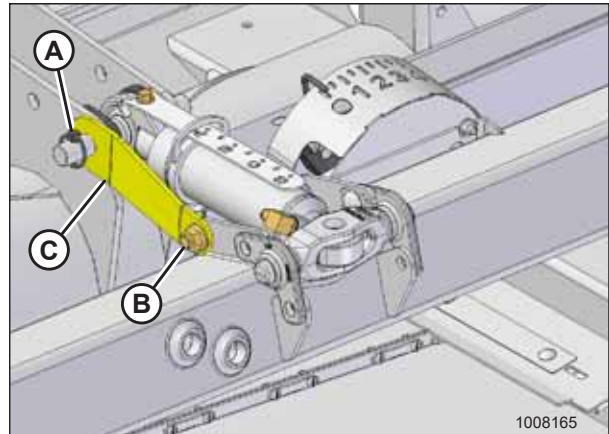

Figure 5.101: Lynch Pin, Hardware, and Shipping Brace

### 5.7.2 Positioning Transport Lights

Transport lights are located on each outboard reel arm. They are shipped in an inverted position on the inboard sides of the reel arms.

1. Position light (A) perpendicular to header. Light arm should move with normal hand force yet maintain its position. If not, proceed to the next step.
2. Loosen jam nut (B) on light attachment bolt, and adjust hex nut (C) as required. Tighten jam nut (B).
3. Repeat above for opposite side.

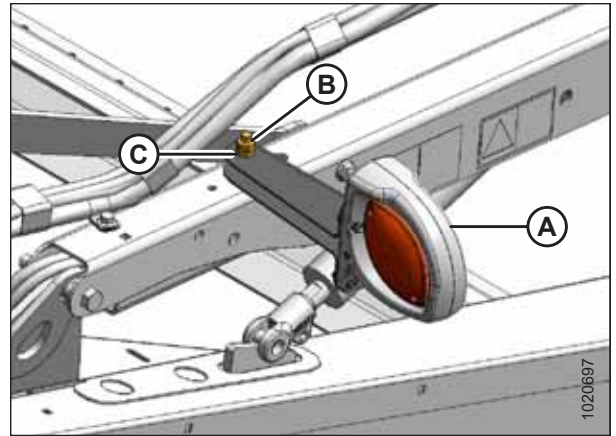

Figure 5.102: Transport Light

### 5.7.3 Crop Dividers

Crop dividers are used to help divide the crop when harvesting. They are removable to allow installation of vertical knives and to decrease transport width.

#### *Removing Crop Dividers from Storage*

Crop dividers are shipped attached to the inboard side of the endsheets. To remove the crop dividers from storage position, follow these steps:

1. Support the crop divider and remove the shipping wire at front end (A).
2. Remove bolt (B).
3. Remove bolt and washer (C) and retain for installation.

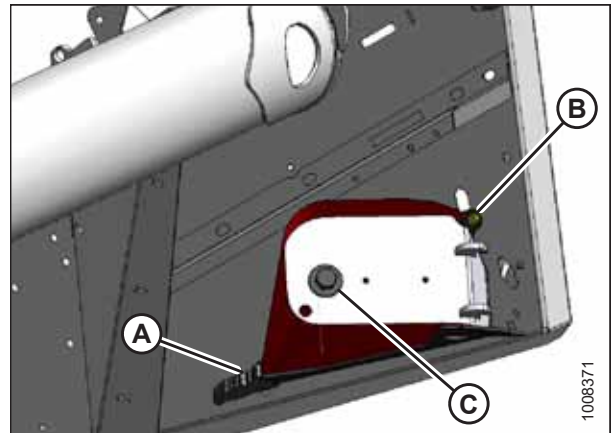

Figure 5.103: Crop Divider Stored on Endsheets

## ATTACHING HEADER TO COMBINE

### Opening Endshields

1. Push release lever (A) located on the backside of the endshield to unlock the shield.
2. Pull the endshield open using handle depression (B).

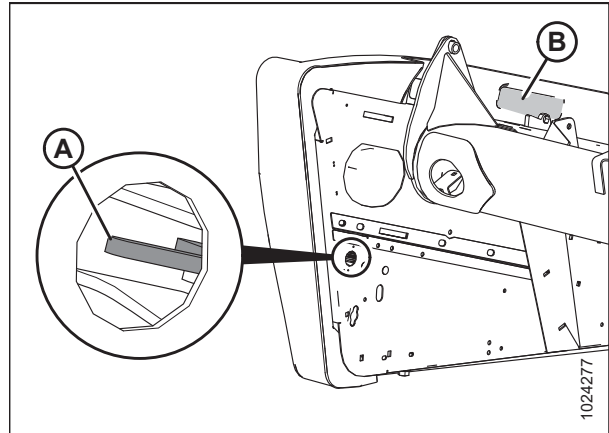

Figure 5.104: Left Endshield

3. Pull the endshield at handle depression (A). The endshield is retained by hinge tab (B) and will open in direction (C).

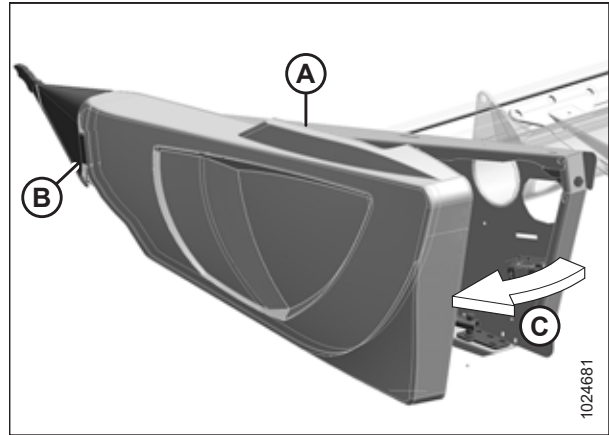

Figure 5.105: Left Endshield

4. If additional clearance is required, pull the endshield free of hinge tab (A) and swing the endshield toward the rear of the header.
5. Engage safety latch (B) on the hinge arm to secure the shield in the fully open position.

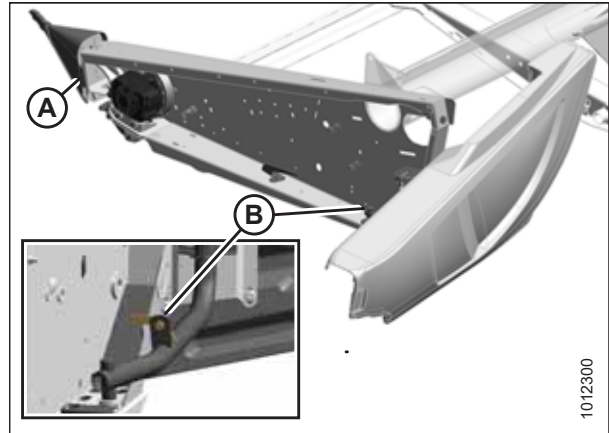

Figure 5.106: Left Endshield

### Installing Crop Divider without Latch Option

#### NOTE:

If the crop divider latch option was ordered with the header, proceed to [Installing Crop Divider with Latch Option, page 130](#). Otherwise, complete the following procedure:

## ATTACHING HEADER TO COMBINE

1. Position crop divider as shown by inserting lugs (A) into holes (B) in endsheet.

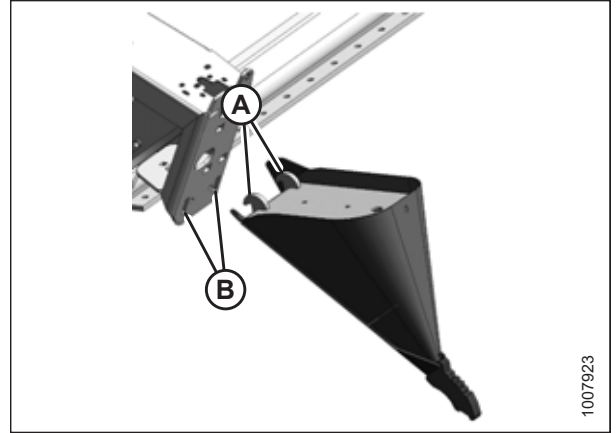

Figure 5.107: Crop Divider without Latch

2. Lift the forward end of the crop divider and install bolt (B) and special stepped washer (A) (step towards divider). Tighten bolt.

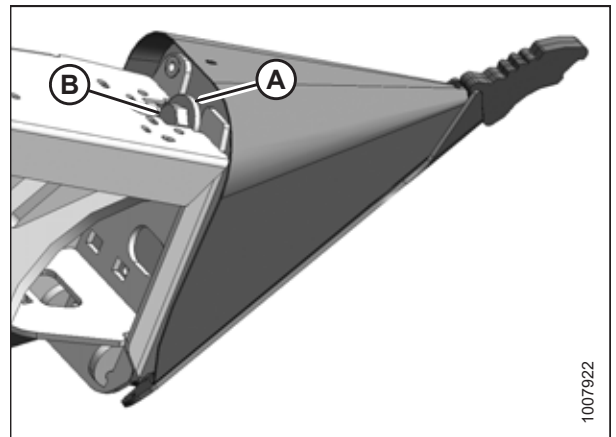

Figure 5.108: Crop Divider without Latch

3. Check that divider does **NOT** move laterally. Adjust bolts (A) as required to tighten divider, and remove lateral play when pulling at divider tip.

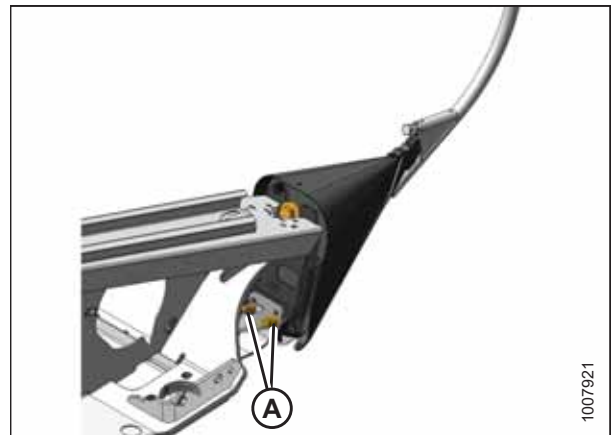

Figure 5.109: Crop Divider Adjustment

## ATTACHING HEADER TO COMBINE

### *Installing Crop Divider with Latch Option*

1. Position the crop divider as shown by inserting lugs (A) into holes in the endsheet.
2. Lift the forward end of the divider until pin (B) engages and closes latch (C).
3. Push safety lever (D) down to lock the pin in latch.

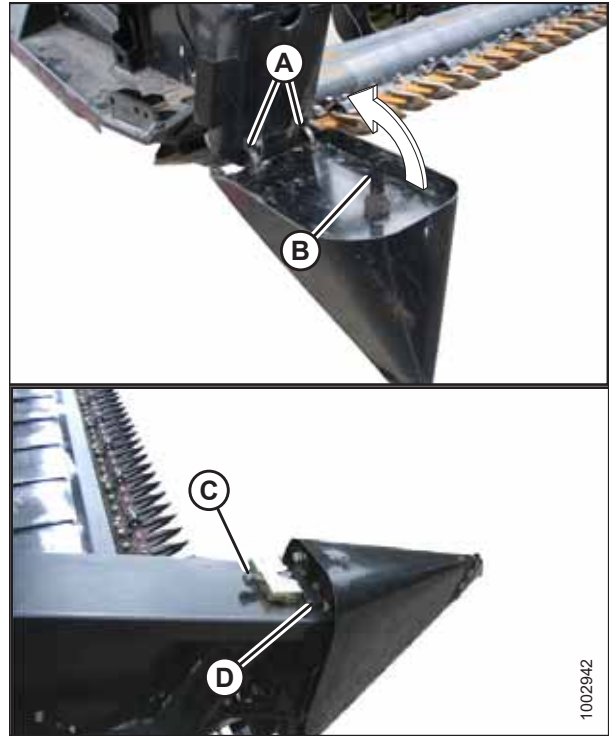

Figure 5.110: Crop Divider with Latch

4. Adjust bolts (A) to tighten divider and remove lateral play when pulling at divider tip.

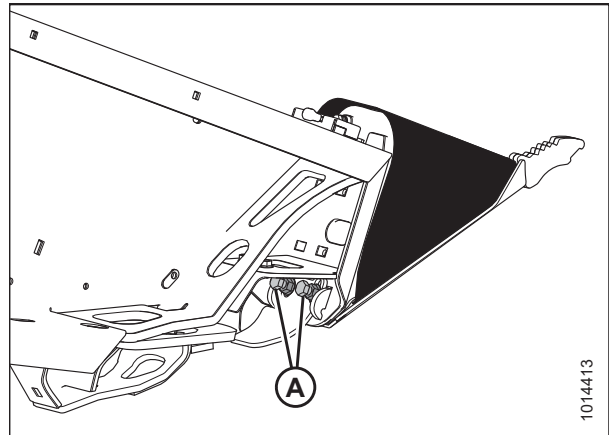

Figure 5.111: Crop Divider Adjustment

## ATTACHING HEADER TO COMBINE

### Closing Endshields

1. Disengage lock (B) to allow the endshield to move.
2. Insert the front of the endshield behind hinge tab (A) and into the divider cone.

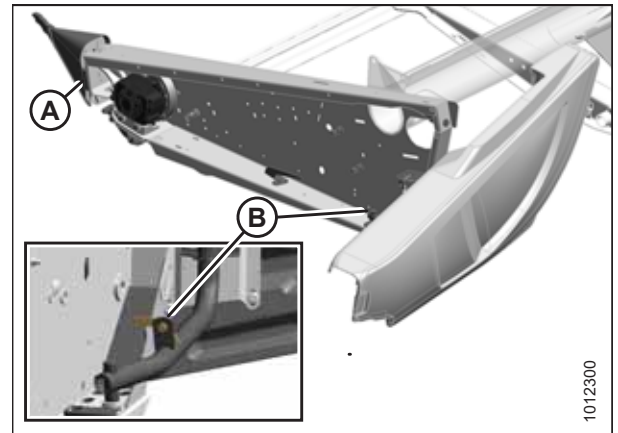

Figure 5.112: Left Endshield

3. Swing the endshield in direction (A) into its closed position. Engage the lock with a firm push.
4. Check that the endshield is locked.

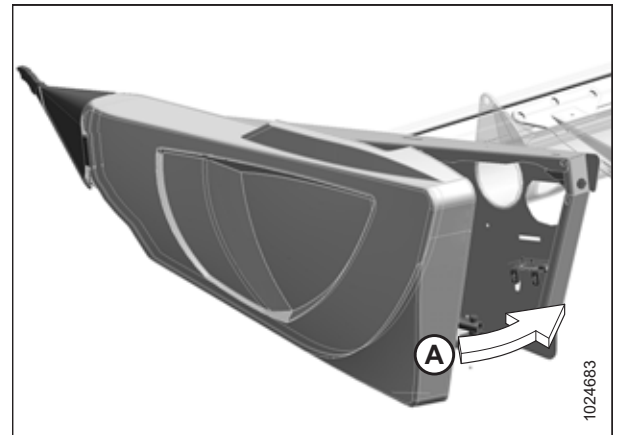

Figure 5.113: Left Endshield

### Installing Crop Divider Rods

1. Remove divider rods from shipping location on header endsheet.
2. Position crop divider rod (B) on tip of crop divider as shown and tighten bolt (A).
3. Repeat procedure at opposite end of header.

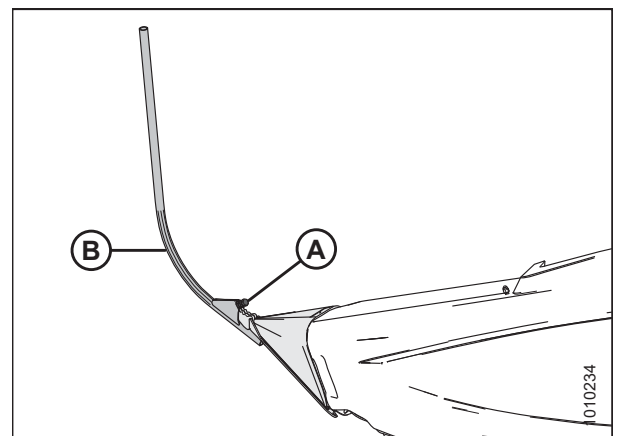

Figure 5.114: Divider Rod on Crop Divider

## 5.7.4 Installing Options

1. Retrieve the kits supplied as options with the header, and install them according to the instructions supplied with each kit.
2. Proceed to Chapter [6 Performing Predelivery Checks, page 133](#).



# Chapter 6: Performing Predelivery Checks

This machine has been set at the factory and should not require further adjustments; however, the following checks will ensure your machine provides maximum performance. If adjustments are necessary, follow the procedures in this chapter.

## **WARNING**

To avoid bodily injury or death from unexpected startup of machine, always stop engine and remove key before adjusting machine.

### **IMPORTANT:**

To avoid machine damage, check that no shipping material has fallen into the machine.

1. Shut down the engine, and remove the key from the ignition.
2. Perform the final checks as listed on the **Predelivery Checklist** (yellow sheet attached to this instruction – *Predelivery Checklist, page 393*) to ensure the machine is field-ready. Refer to the following pages for detailed instructions as indicated on the Checklist. The completed Checklist should be retained by either the Operator or the Dealer.

## 6.1 Recording Model and Serial Number

Record the machine serial numbers on the Predelivery Checklist.

### **FD1 Series FlexDraper® Header**

Header Model: \_\_\_\_\_  
Serial Number: \_\_\_\_\_  
Year: \_\_\_\_\_

Header serial number plate (A) is located on the upper corner on the left endsheet.

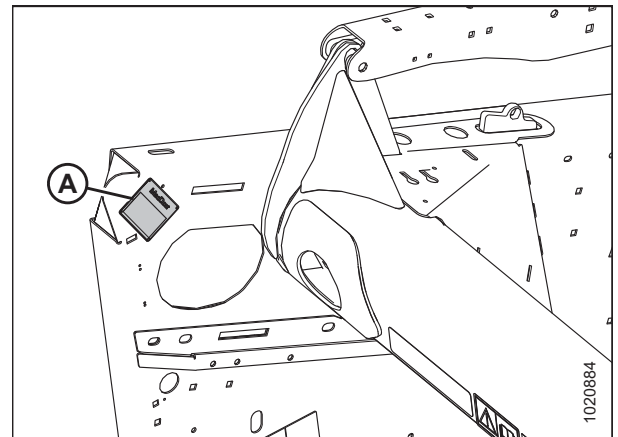

Figure 6.1: Header Serial Number Plate Location

### **FM100 Float Module for Combine**

Serial Number: \_\_\_\_\_  
Year: \_\_\_\_\_

Float module serial number plate (A) is located on the top left of the float module frame.

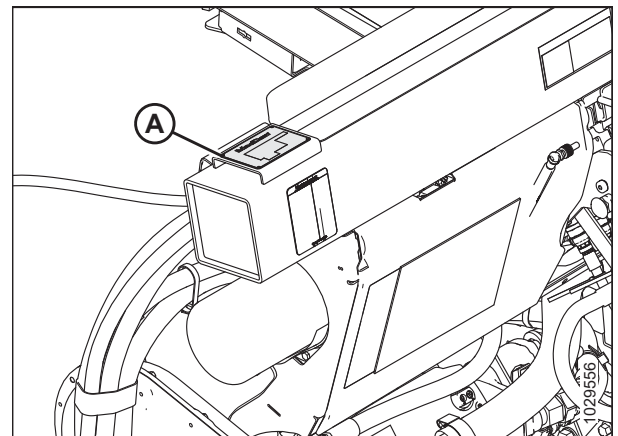

Figure 6.2: Float Module Serial Number Plate Location

## PERFORMING PREDELIVERY CHECKS

### Transport / Stabilizer Wheel Option

Serial Number: \_\_\_\_\_

Year: \_\_\_\_\_

Transport serial number plate (A) is located on the right axle assembly.



Figure 6.3: Transport / Stabilizer Wheel

## 6.2 Checking Tire Pressure – Transport and Stabilizer Wheels

Check tire inflation pressure. If necessary, inflate tires according to the following table:

**Table 6.1 Tire Inflation Pressure**

Size	Load Range	Pressure
ST205/75 R15	D	448 kPa (65 psi)
	E	552 kPa (80 psi)

**IMPORTANT:**

Do **NOT** exceed maximum pressure specified on tire sidewall.

## 6.3 Checking Wheel Bolt Torque – Transport and Stabilizer Wheels

Perform the following procedure to ensure that transport and stabilizer wheel bolts are correctly torqued:

1. Check that wheel bolt torque is 110–120 Nm (80–90 lbf-ft).
2. If necessary, adjust torque. Refer to bolt tightening sequence illustration at right.

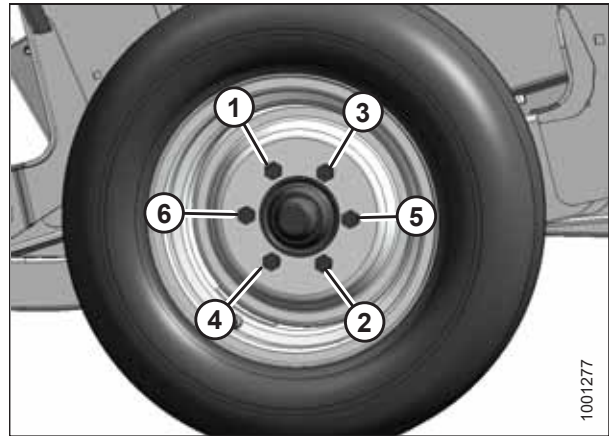

Figure 6.4: Sequence for Tightening Bolts

## 6.4 Checking Knife Drive Box

Single-knife headers have one knife drive box and double-knife headers have two knife drive boxes. To access the knife drive box(es), the endshield(s) must be fully opened.

### DANGER

To avoid bodily injury or death from unexpected startup of machine, always stop the engine and remove the key before making adjustments to the machine.

1. Shut down the engine, and remove the key from the ignition.
2. Press down on latch (A) in the opening on the inboard side of the endsheet.
3. Pull endshield open using handle depression (B).

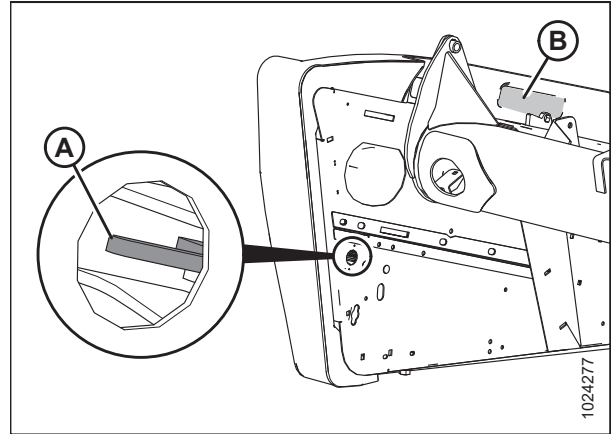

Figure 6.5: Endshield Latch Access

4. Swivel the endshield toward the back of the header and use safety latch (B) to secure endshield support tube (A) to the endsheet.

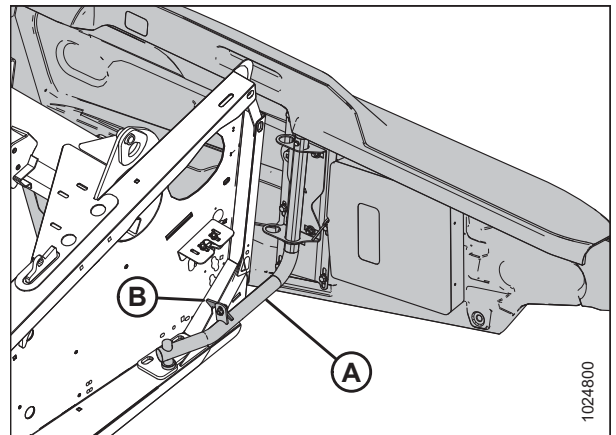

Figure 6.6: Left Endshield Support Tube

## PERFORMING PREDELIVERY CHECKS

### IMPORTANT:

The knife drive box breather is shipped in position (A) (forward) to prevent oil loss during transport. The breather **MUST** be repositioned to location (B) to prevent oil loss during normal operation. Failure to do so can result in damage to the knife drive box.

5. Check position of plug (A) and breather (B) at knife drive box. Position **MUST** be as shown.
6. Remove breather (B) and check oil level. The oil level should be between bottom edge (C) of lower hole (D) and bottom (E) of the breather.

### NOTE:

Check oil level with top of knife drive box horizontal and with breather (B) screwed in.

7. Reinstall breather and tighten.

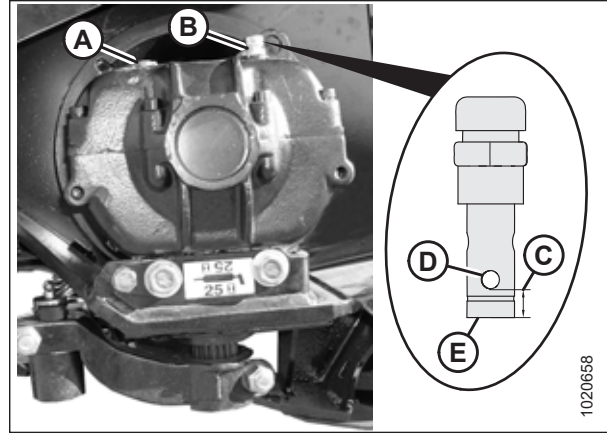

Figure 6.7: Knife Drive Box

## 6.5 Checking Oil Level in Header Drive Gearbox

### WARNING

To avoid injury or death from unexpected start-up of machine, always stop the engine and remove the key from the ignition before leaving the operator's seat for any reason.

1. Lower the header to the ground and ensure the gearbox is in working position.
2. Shut down the engine, and remove the key from the ignition.
3. Remove oil level plug (A) and check that the oil level is up to the bottom of the hole.
4. Reinstall oil level plug (A).

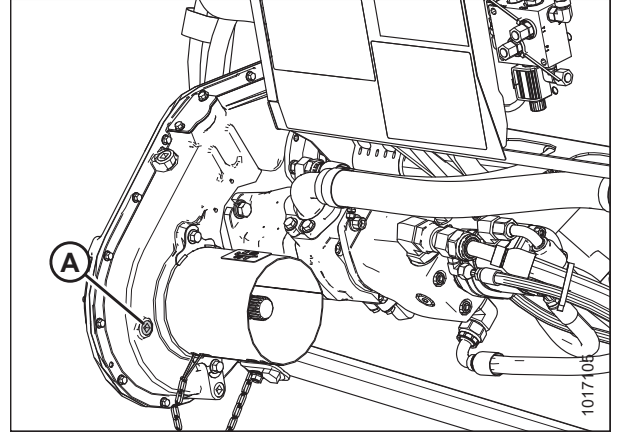

Figure 6.8: Header Drive Gearbox

## 6.6 Checking Oil Level in Hydraulic Reservoir

1. Check the oil level using lower sight (A) and upper sight (B) with the cutterbar just touching the ground and with the center-link retracted.

**NOTE:**

Check the level when the oil is cold.

**NOTE:**

For extremely hilly terrain, a hillside extension kit can be installed.

2. Ensure the oil is at the appropriate level for the terrain as follows:
  - **Hilly terrain:** Maintain level so lower sight (A) is full, and upper sight (B) is up to one-half filled.
  - **Normal terrain:** Maintain level so lower sight (A) is one-half full, and upper sight (B) is empty.

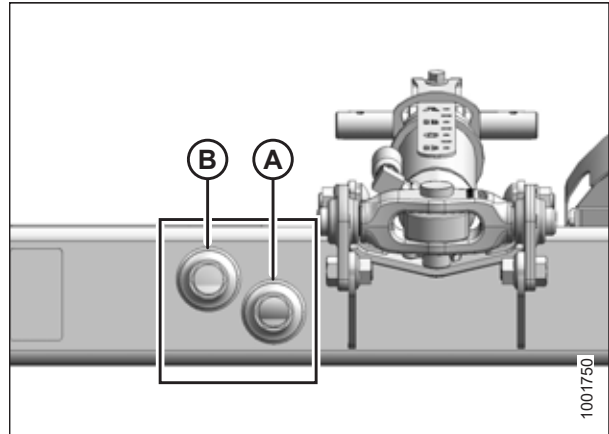

Figure 6.9: Oil Level Sight Glass



## 6.7 Checking Knife Drive Belt Tension

### WARNING

To avoid bodily injury or death from unexpected startup of machine, always stop engine and remove key before adjusting machine.

1. Open endshield(s). For instructions refer to *Opening Endshields, page 128*.

**NOTE:**

The knife drive is identical on both sides of the header.

2. Check belt (C) tension by applying 90 N (20 lbf) by hand to belt at mid-span, and check that belt deflects 18 mm (3/4 in.). If necessary adjust tension as follows:
  - a. Loosen two bolts (A) that secure the motor assembly to header endsheet.
  - b. Turn adjuster bolt (B) as required (clockwise to tighten) to achieve specified tension.

**IMPORTANT:**

To prolong belt and drive life, do **NOT** over-tighten belt.

3. Ensure that clearance between belt (A) and belt guide (B) is 1 mm (1/32 in.).
4. If required, loosen three bolts (C), and adjust position of guide (B).
5. Tighten bolts (C).
6. Close endshield(s). For instructions, refer to *Closing Endshields, page 131*.

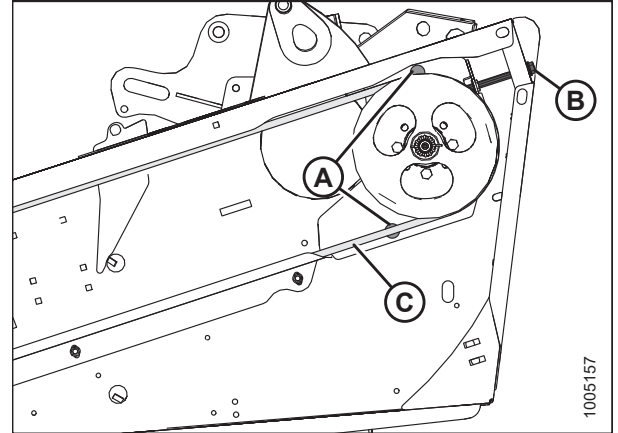

Figure 6.10: Left Side of Header Shown – Right Opposite for Double-Knife Headers

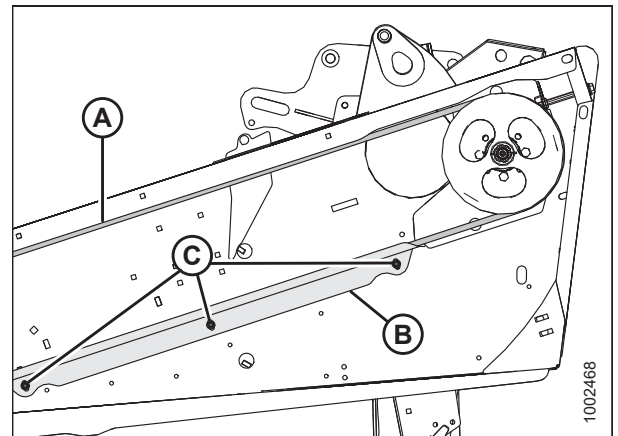

Figure 6.11: Knife Drive

## 6.8 Checking Pointed Guard Hold-Downs

This procedure is applicable to headers with pointed guards.

### WARNING

To avoid bodily injury or death from unexpected startup of machine, always stop engine and remove key before adjusting machine.

Measure clearance between hold-downs and knife sections as follows:

1. Shut down the combine, and remove the key from the ignition.
2. Check guard alignment and adjust as required. Refer to [9.2.1 Adjusting Knife](#), page 375.
3. Manually stroke knife to align section (A) under hold-down (B).
4. At standard guard locations, push knife section (A) down against guard (C) and measure clearance between hold-down (B) and knife section (A) with a feeler gauge. The clearance should be 0.1–0.6 mm (0.004–0.024 in.).
5. If necessary, refer to [6.8.1 Adjusting Pointed Guard Hold-Downs](#), page 143.

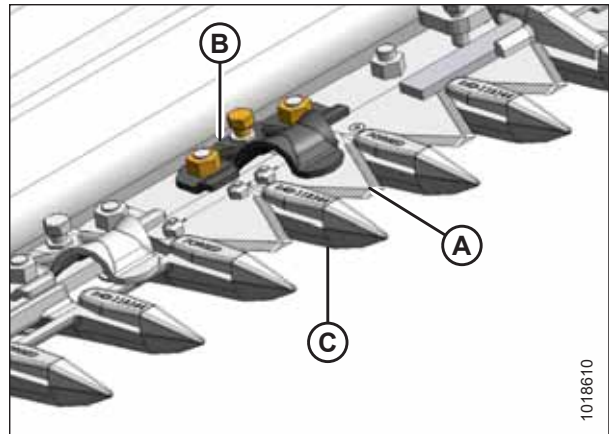

Figure 6.12: Normal Guard Hold-Down

#### **Double knife:**

6. Manually stroke knife to align sections (A) and (C) under center hold-down (B).
7. Measure between knife sections (A) and (C) with a feeler gauge. The clearances should be as follows:
  - At tip of hold-down: 0.1–0.4 mm (0.004–0.016 in.)
  - At rear of hold-down: 0.1–1.0 mm (0.004–0.040 in.)
8. If necessary, refer to [6.8.2 Adjusting Hold-Down Clips at Double-Knife Center Pointed Guard](#), page 143.

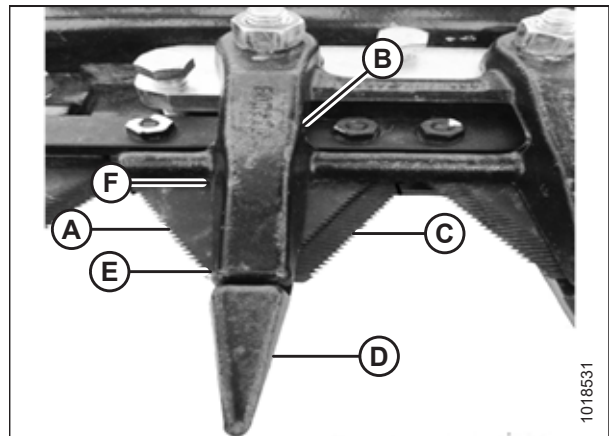

Figure 6.13: Double-Knife Center Guard Hold-Down

### 6.8.1 Adjusting Pointed Guard Hold-Downs

This procedure is applicable to formed sheet metal hold-downs. Do **NOT** use this procedure for the hold-down at center guard position where knives overlap on double-knife headers. For center guard, refer to [6.8.2 Adjusting Hold-Down Clips at Double-Knife Center Pointed Guard](#), [page 143](#).

#### **WARNING**

To avoid bodily injury or death from unexpected startup of machine, always stop engine and remove key before adjusting machine.

1. Shut down the combine, and remove the key from the ignition.
2. Decrease clearance by turning bolt (B) clockwise to lower front of hold-down (A).
3. Increase clearance by turning bolt (B) counterclockwise to raise front of hold-down.

**NOTE:**

For larger adjustments, it may be necessary to loosen nuts (C), turn adjuster bolt (B), and then retighten nuts.

4. Check clearance again and adjust as required.

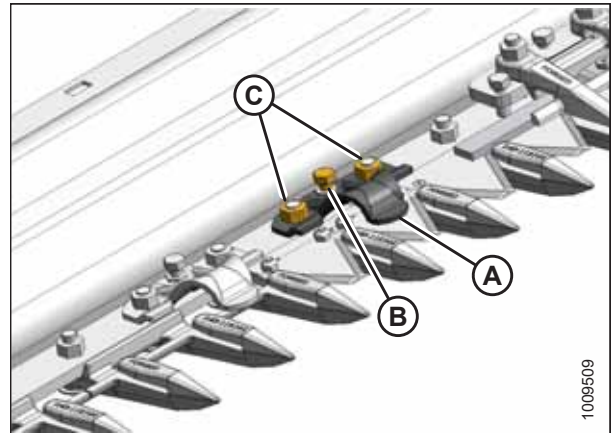

Figure 6.14: Cutterbar

### 6.8.2 Adjusting Hold-Down Clips at Double-Knife Center Pointed Guard

#### **WARNING**

To avoid bodily injury or death from unexpected startup of machine, always stop engine and remove key before adjusting machine.

1. Shut down the combine, and remove the key from the ignition.
2. Manually stroke knives so that sections (A) are under hold-down (B) as shown.
3. Loosen nuts (C) and back off bolts (D) until they don't contact the cutterbar.
4. Lightly clamp hold-down (B) to guard (E) with a C-clamp or equivalent. Position clamp on trash bar at location (F) as shown.
5. Turn bolts (D) until they contact cutterbar, then tighten **ONE** turn.
6. Remove clamp.
7. Tighten nuts (C) and torque to 88 Nm (65 lbf-ft).
8. Check clearances. For instructions, refer to [6.8 Checking Pointed Guard Hold-Downs](#), [page 142](#).

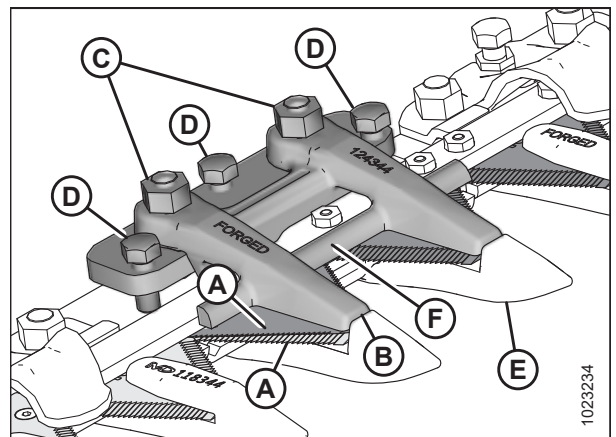

Figure 6.15: Center Guard

## 6.9 Centering Reel on Double-Reel Header

### WARNING

To avoid bodily injury or death from unexpected startup of machine, always stop engine and remove key before adjusting machine.

1. Unlock the wings.
2. Start the engine.
3. Lower reel and adjust fore-aft position to 5 on reel arm indicator decal.
4. Raise the header enough to put 150 mm (6 in.) blocks under the outboard skid shoes.
5. Lower the header onto the blocks, the ends of the header will be higher than the center section, causing the header to smile.
6. Shut down the engine, and remove the key from the ignition.
7. Measure clearance (A) at locations (B) between reel tine tube and endsheet at both ends of header. The clearances should be the same if reel is centered. Refer to the following steps to center reel.

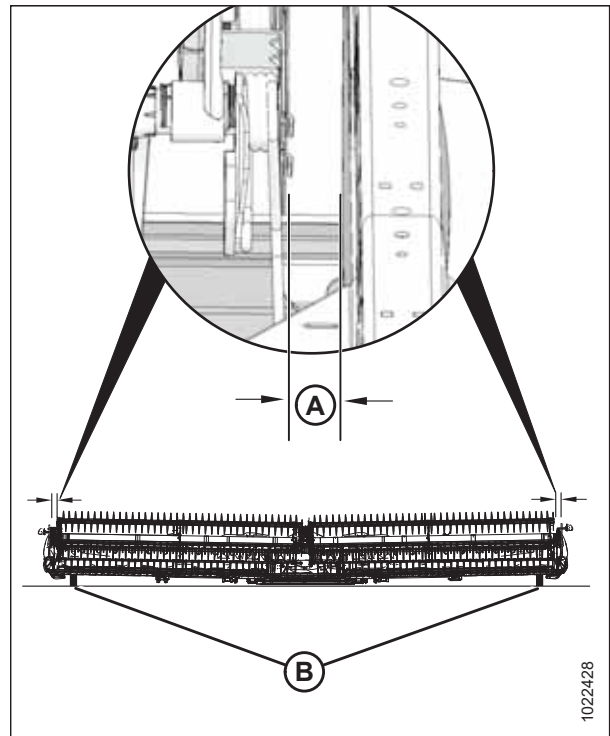

Figure 6.16: Centering Reel – Double Reel

## PERFORMING PREDELIVERY CHECKS

8. Loosen bolts (A) on braces (B) at center support arm.
9. Move forward end of reel support arm (C) laterally as required to center reel.
10. Tighten bolts (A) and torque to 382 Nm (282 lbf-ft).

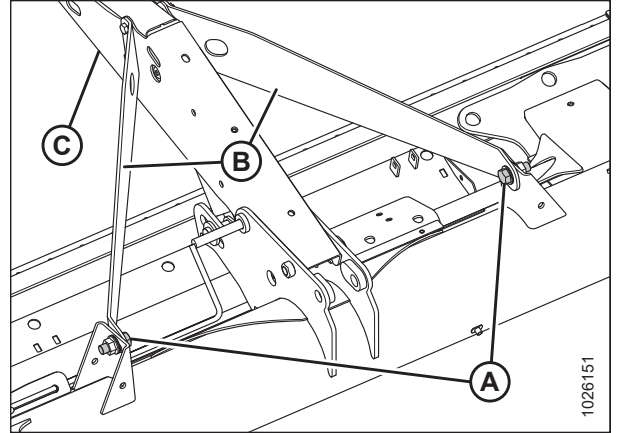

Figure 6.17: Center Support Arm and Braces



## PERFORMING PREDELIVERY CHECKS

8. Loosen bolt (A) on brace (B) on the right side of the reel.
9. Move the forward end of reel support arm (C) laterally as required to center the reel.
10. Tighten bolt (A) and torque to 382 Nm (282 lbf-ft).

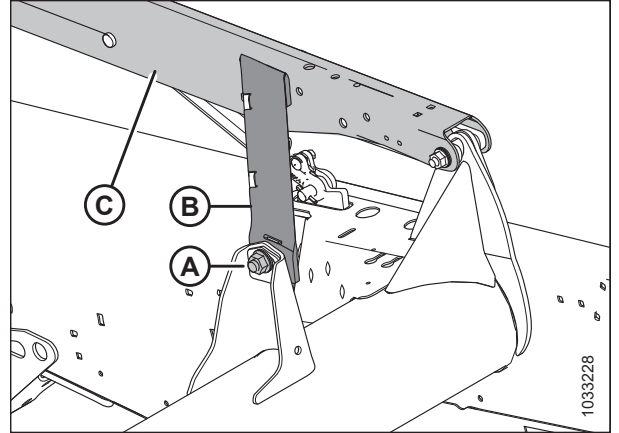

Figure 6.19: Reel Support Arm

## 6.11 Checking and Adjusting Header Float

The header is equipped with a suspension system that floats the header over the ground to compensate for ridges, trenches, and other variations in ground contour. If the header float is not set properly, it may cause the cutterbar to push into the ground or leave uncut crop. This procedure describes how to check header float and adjust to the factory-recommended settings.

### WARNING

To avoid injury or death from unexpected start-up of machine, always stop the engine and remove the key from the ignition before leaving the operator's seat for any reason.

Use the following guidelines when adjusting float:

- Turn each adjustment bolt pair equally. Repeat torque wrench reading procedure on both sides of header.
- Set the header float as light as possible without causing excessive bouncing to prevent knife component breakage, soil scooping, and soil build-up at the cutterbar in wet conditions.
- To avoid excessive bouncing and leaving a ragged cut, use a slower ground speed with a light float setting, if necessary.
- When cutting off the ground, use the stabilizer wheels in conjunction with header float to minimize bouncing at the header ends and to control cut height.

### NOTE:

If adequate header float cannot be achieved using all of the available adjustments, an optional heavy-duty spring is available.

To check and adjust header float, follow these steps:

1. Park the combine on a level surface.
2. Level the header and float module. If the header and float module are not level, perform the following checks before adjusting the float:

#### IMPORTANT:

Do **NOT** use the float module springs to level the header.

- Check that the combine feeder house is level. For instructions, refer to your combine operator's manual.
  - Check that the top of the float module is level with the combine axle.
  - Ensure the combine tires are inflated equally.
3. Adjust header so that the cutterbar is 150–254 mm (6–10 in.) off the ground.
  4. Extend the header angle hydraulic cylinder to between **B** and **C** on indicator (**A**).

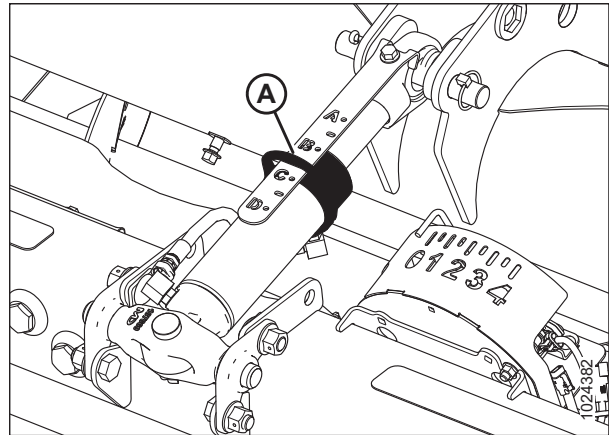

Figure 6.20: Center-Link



## PERFORMING PREDELIVERY CHECKS

5. Adjust the reel fore-aft position to between 5 and 6 on position indicator decal (A) located on the reel right arm.
6. Lower the reel fully.
7. Shut down the engine, and remove the key from the ignition.

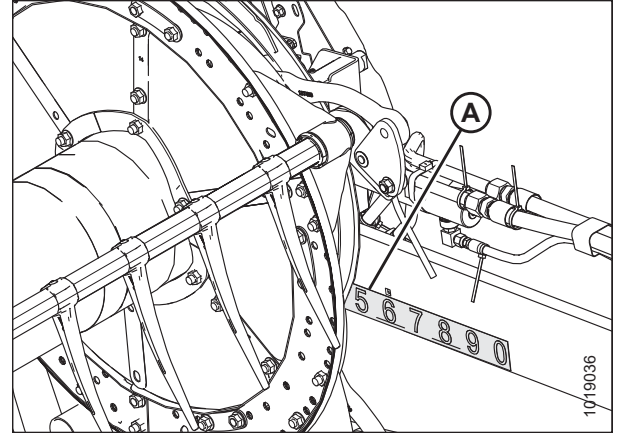

Figure 6.21: Fore-Aft Position

8. Place wing lock spring handles (A) in the **LOCKED** (upper) position.

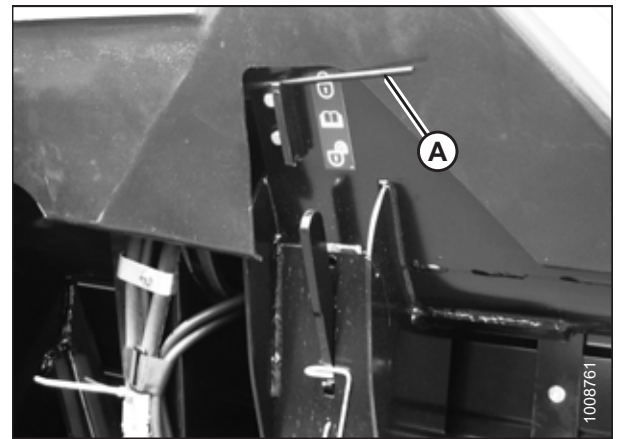

Figure 6.22: Wing Lock Spring Handle in Lock Position

## PERFORMING PREDELIVERY CHECKS

9. Disengage both header float locks by pulling float lock handle (A) away from the float module and pushing the float lock handle down and into position (B) (**UNLOCK**).

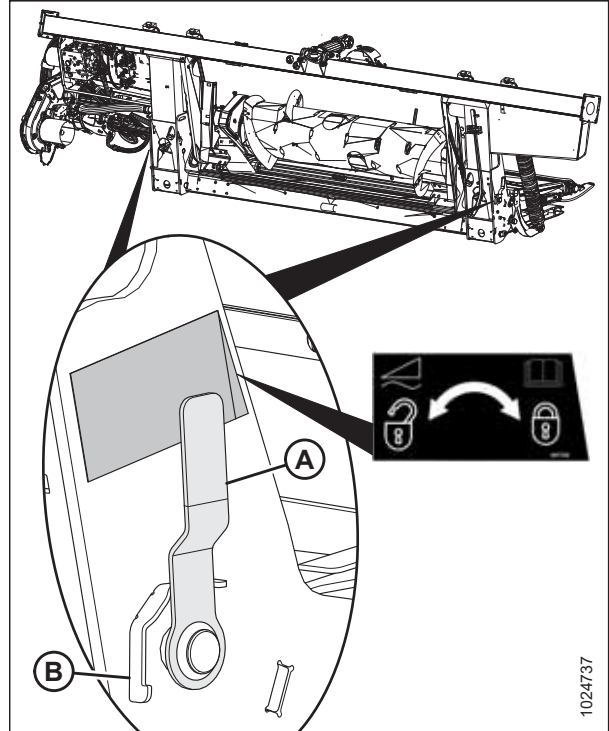

Figure 6.23: Header Float Lock in Locked Position

10. Place stabilizer wheels and transport wheels (if equipped) in storage position as follows:
  - a. Support the wheel weight by lifting slightly with one hand, and pull up on handle (A) to release the lock.
  - b. Lift the wheels to the desired height, and engage the support channel into slot (B) in the upper support.
  - c. Push down on handle (A) to lock.

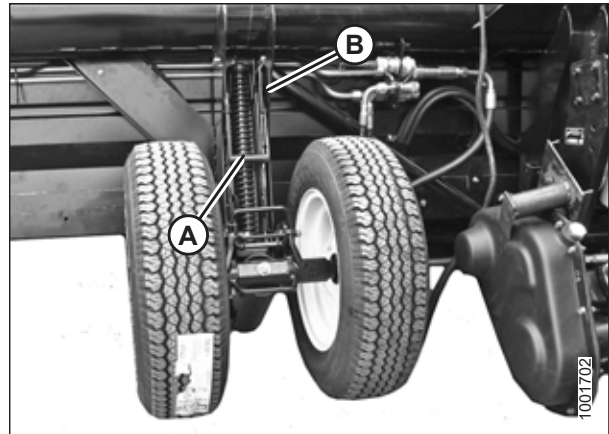

Figure 6.24: Left Wheel

## PERFORMING PREDELIVERY CHECKS

11. Remove supplied torque wrench (A) from its storage position at the right side of the float module frame. Pull in the direction shown to disengage the wrench from the hook.

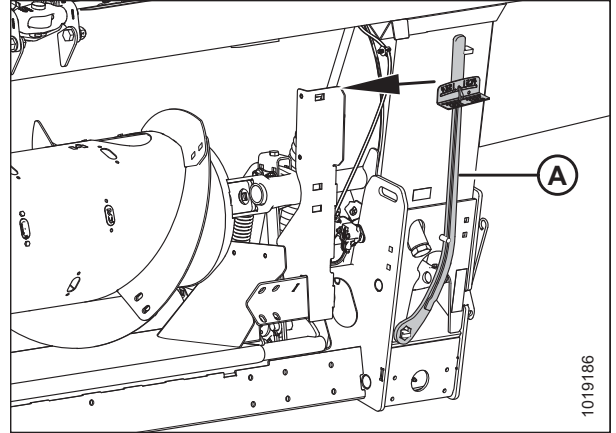

Figure 6.25: Torque Wrench Storage Location

12. Place torque wrench (A) onto float lock (B). Note the position of the wrench for checking left or right side.
13. Push down on wrench to rotate bell crank (C) forward.

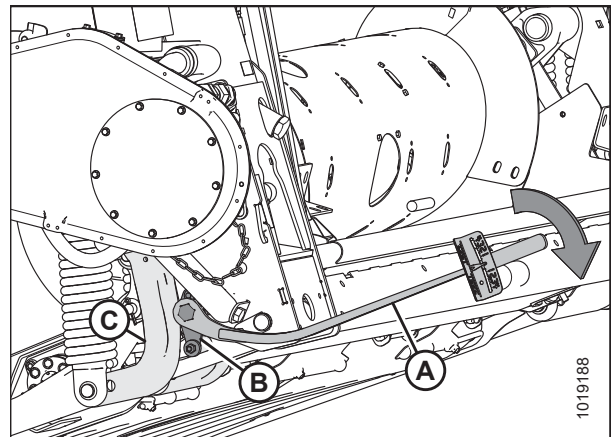

Figure 6.26: Float Module – Left Side

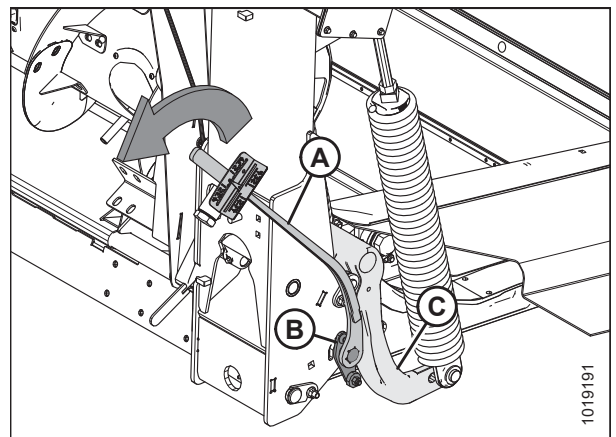

Figure 6.27: Float Module – Right Side

## PERFORMING PREDELIVERY CHECKS

14. Push down on the wrench until indicator (A) reaches a maximum reading and then begins to decrease. Note the maximum reading. Repeat at opposite side.
15. Use the following table as a guide for float settings:
  - If reading on the wrench is high, the header is heavy
  - If reading on the wrench is low, the header is light

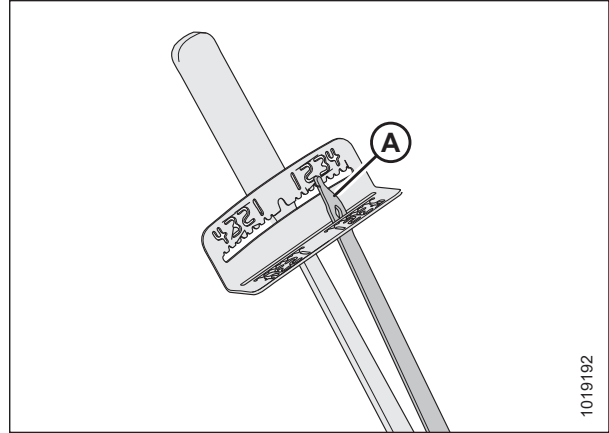

Figure 6.28: Torque Wrench

Table 6.2 Float Settings

Header Size	Indicator Reading	
	Cutting on the Ground	Cutting off the Ground
FD125, FD130, and FD135	1 1/2 to 2	2 to 2 1/2
FD140 and FD145	2 to 2 1/2	2 1/2 to 3

16. To access float spring adjustment bolts (A), loosen bolts (C) and rotate spring locks (B).
17. To increase float (decrease header weight), turn both adjustment bolts (A) on the left side clockwise. Repeat adjustment at opposite side.

To decrease float (increase header weight), turn left side adjustment bolts (A) counterclockwise. Repeat at opposite side.

**NOTE:**

Turn each bolt pair equally.

18. Adjust the float so the wrench readings are equal on both sides of the header.

**NOTE:**

**For 12.2 and 13.7 m (40 and 45 ft.) double-knife headers:** adjust the float so the wrench readings are equal at both sides, and then loosen both right side spring bolts two turns.

19. Lock adjustment bolts (A) with spring locks (B). Ensure bolt heads (A) are engaged in the spring lock cutouts. Tighten bolts (C) to secure spring locks in place.
20. Proceed to [6.12.2 Adjusting Wing Balance, page 158](#).

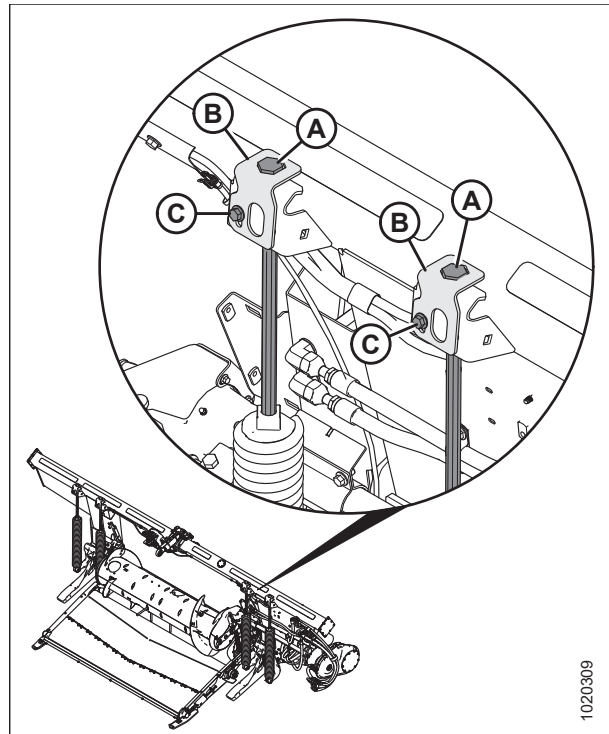

Figure 6.29: Float Adjustment – Left Side

## 6.12 Checking and Adjusting Header Wing Balance

**IMPORTANT:**

Before proceeding, the header float must be set properly. For instructions, refer to [6.11 Checking and Adjusting Header Float, page 148](#).

The header wing balance allows the wings to react to changing ground conditions. If set too light, the wings will bounce or not follow ground contours, leaving uncut crop. If set too heavy, the end of the header will dig into the ground. After the header float has been set, the wings must be balanced for the header to follow the ground contours properly.

### 6.12.1 Checking Wing Balance

This procedure describes how to check the balance of each wing.

**IMPORTANT:**

To ensure correct wing balance readings, make sure the header float is set properly before proceeding. For instructions, refer to [6.11 Checking and Adjusting Header Float, page 148](#).

**WARNING**

To avoid bodily injury or death from unexpected startup of machine, always stop engine and remove key before adjusting machine.

If a header wing has a tendency to be in a smile (A) or a frown (B) position, wing balance may require adjusting. Perform the following steps to check if the wings are not balanced, and how much adjustment is required.

The header wings are balanced when it takes an equal amount of force to move a wing up or down.

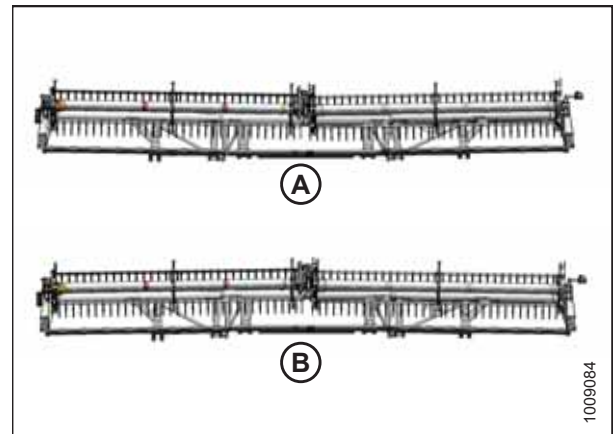

Figure 6.30: Wing Imbalance

1. Adjust the reel fore-aft position to between 5 and 6 on the position indicator decal (A) located on the reel right arm.
2. Lower the reel fully.

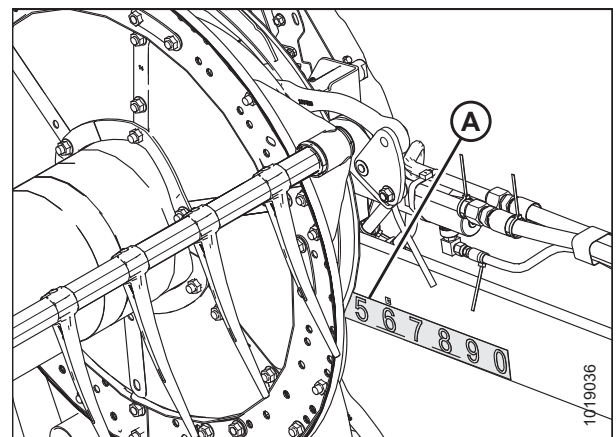

Figure 6.31: Fore-Aft Position

## PERFORMING PREDELIVERY CHECKS

3. Adjust center-link (A) so that indicator (B) is between **B** and **C** on gauge (C).
4. Park combine on level ground and raise header until cutterbar is 152–254 mm (6–10 in.) off the ground.
5. Shut down the engine, and remove the key from the ignition.
6. If installed, move stabilizer/transport wheels so that they are supported by header. Refer to the instructions provided with the stabilizer/transport system.

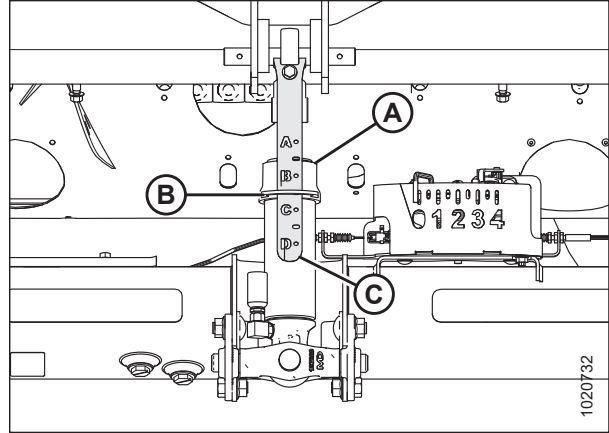

Figure 6.32: Center-Link

7. Remove linkage cover (A) by removing bolt (B) and rotating cover upward until inboard end can be lifted off.

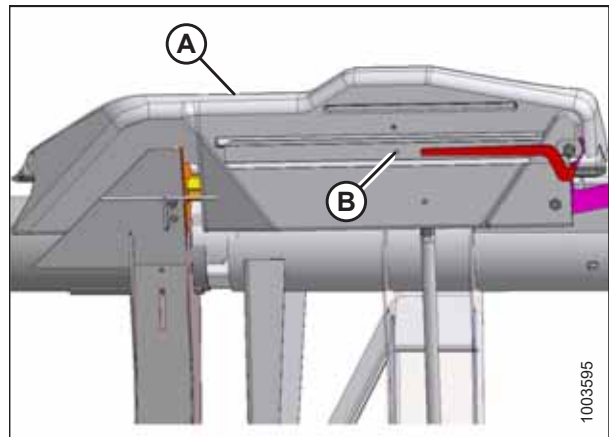

Figure 6.33: Linkage Cover

### NOTE:

Refer to decal (A) inside each linkage cover.

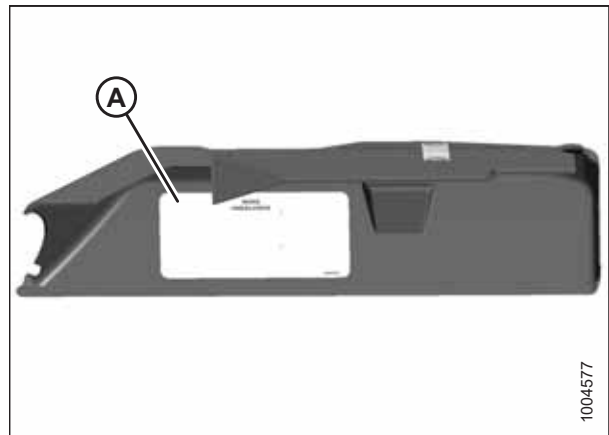

Figure 6.34: Linkage Cover

## PERFORMING PREDELIVERY CHECKS

- Unlock the wings by moving spring handles (A) to lower (UNLOCK) position.

**NOTE:**

If lock link does not engage lower slot, move wing with the torque wrench until lock link moves into slot.

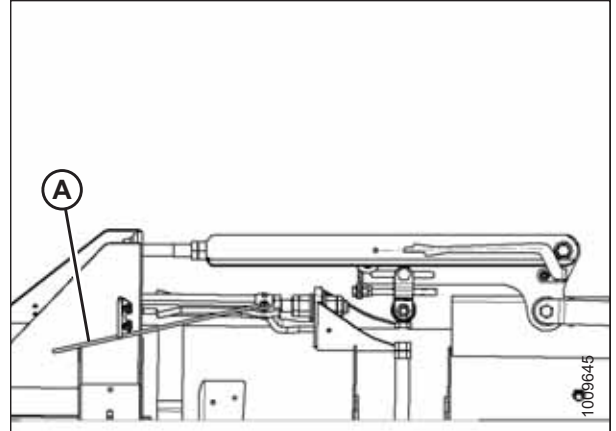

Figure 6.35: Wing Lock in UNLOCK Position

- Retrieve wrench (A) from float module right leg.

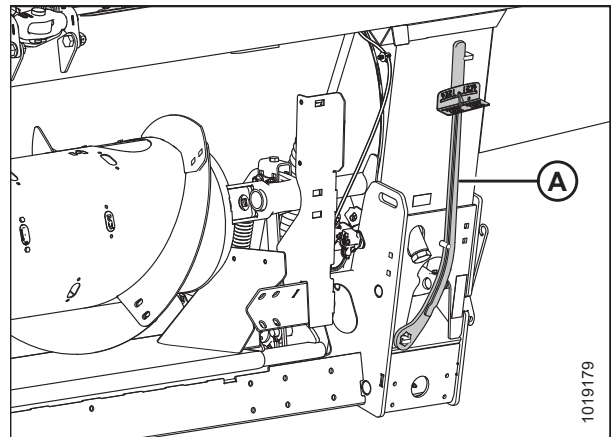

Figure 6.36: Torque Wrench

- Place torque wrench (A) onto bolt (B).

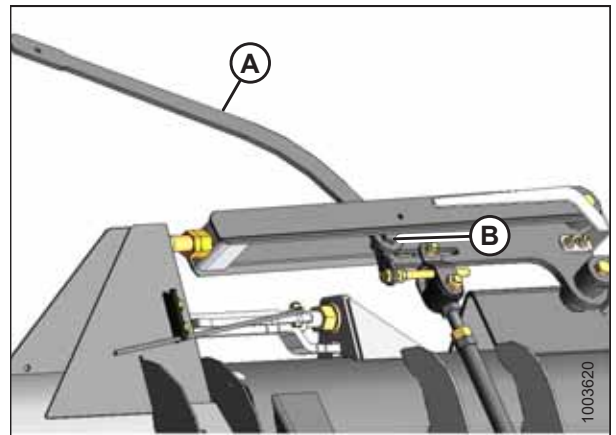

Figure 6.37: Balance Linkage

## PERFORMING PREDELIVERY CHECKS

11. Check that pointer (D) is properly positioned as follows:
  - a. Use wrench (A) to move bell crank (B) so that lower edge of bell crank is parallel to top-link (C).
  - b. Check that pointer (D) is lined up with the top-link (C). Bend pointer if necessary.

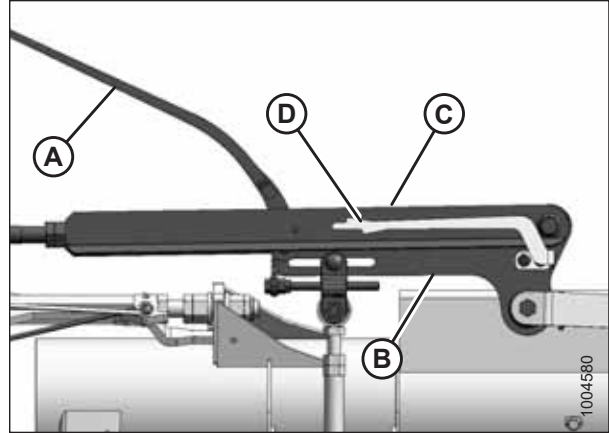

Figure 6.38: Balance Linkage

12. Move wing upward with torque wrench (A) until the pointer's lower alignment tab (C) lines up with the upper edge of top-link (B). Observe indicator reading (D) on the wrench and record it.

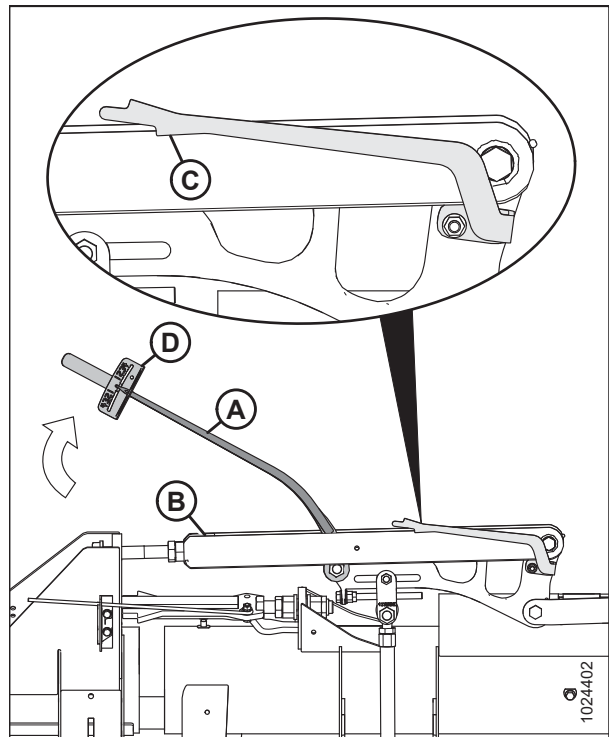

Figure 6.39: Balance Linkage



## PERFORMING PREDELIVERY CHECKS

13. Move wing downward with torque wrench (A) until the pointer's upper alignment tab (C) lines up with the lower edge of top-link (B). Observe indicator reading (A) on the wrench and record it.
14. Compare the readings taken in Step 12, [page 156](#) and Step 13, [page 157](#).
  - If the difference between the readings is 0.5 or less, the wing is balanced and no further adjustment is required. To reinstall the linkage cover, refer to Step 15, [page 158](#) and Step 16, [page 158](#).
  - If the difference between the readings is more than 0.5, the wing is not balanced. For instructions, refer to [6.12.2 Adjusting Wing Balance, page 158](#).

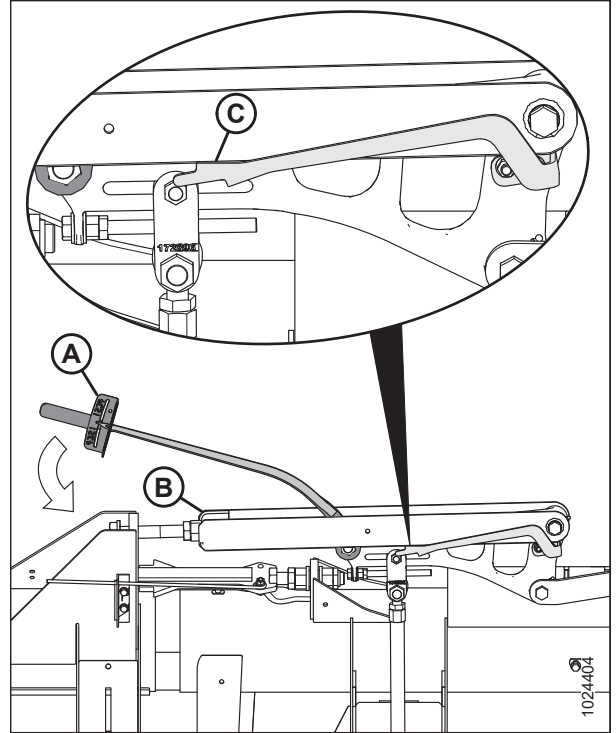

Figure 6.40: Balance Linkage

- If the indicator range is as shown, the wing is too light.

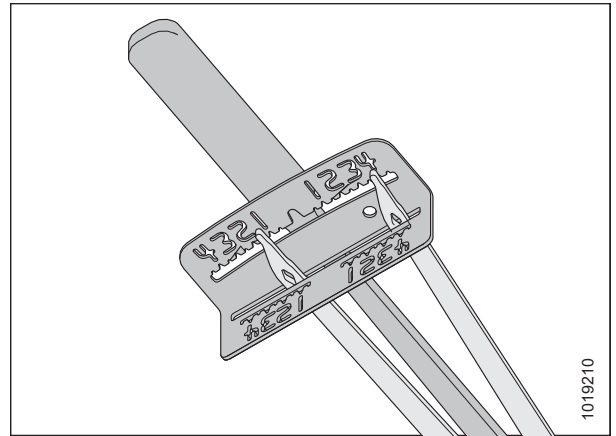

Figure 6.41: Wrench Indicator

## PERFORMING PREDELIVERY CHECKS

- If the indicator range is as shown, the wing is too heavy.

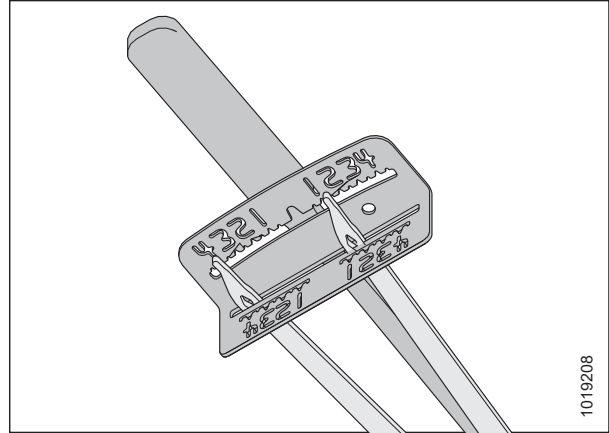

Figure 6.42: Wrench Indicator

15. If no adjustment is required, place wrench (A) back onto the float module right leg.

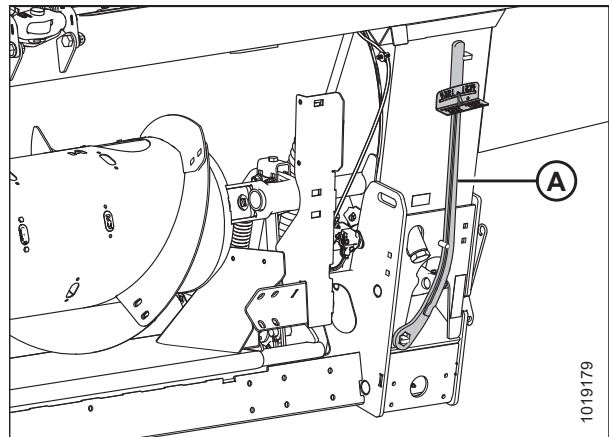

Figure 6.43: Torque Wrench

16. If no adjustment is required, reinstall linkage cover (A) and secure it with bolt (B). If adjustment is required, refer to [6.12.2 Adjusting Wing Balance, page 158](#).

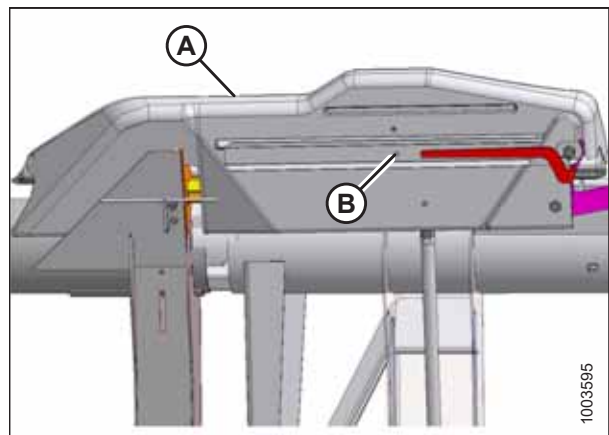

Figure 6.44: Linkage Cover

### 6.12.2 Adjusting Wing Balance

#### WARNING

To avoid bodily injury or death from unexpected startup of machine, always stop engine and remove key before adjusting machine.

## PERFORMING PREDELIVERY CHECKS

This procedure describes how to adjust the balance of each wing. Before proceeding, refer to [6.12.1 Checking Wing Balance, page 153](#) to determine if adjustments are necessary.

### IMPORTANT:

To ensure correct wing balance readings, make sure the header float is set properly before proceeding. For instructions, refer to [6.11 Checking and Adjusting Header Float, page 148](#). The float module must be sitting level before performing any adjustments.

1. Place torque wrench (A) on bolt (B). Check that wing lock (C) is in lower position.

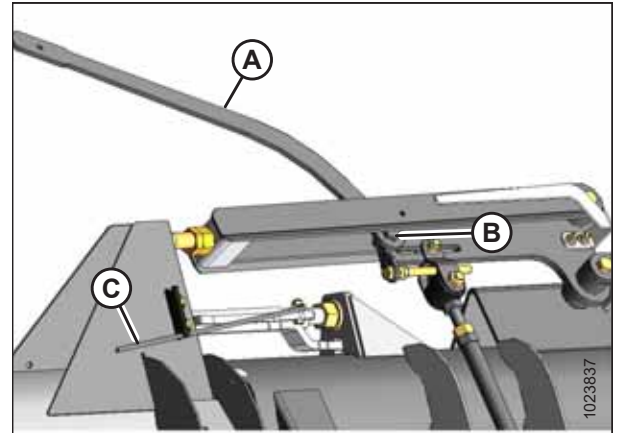

Figure 6.45: Balance Linkage – Left Side

2. Loosen nut (A) on clevis bolt for the wing requiring adjustment as determined by the wing balance check.
3. Loosen jam nut (B).

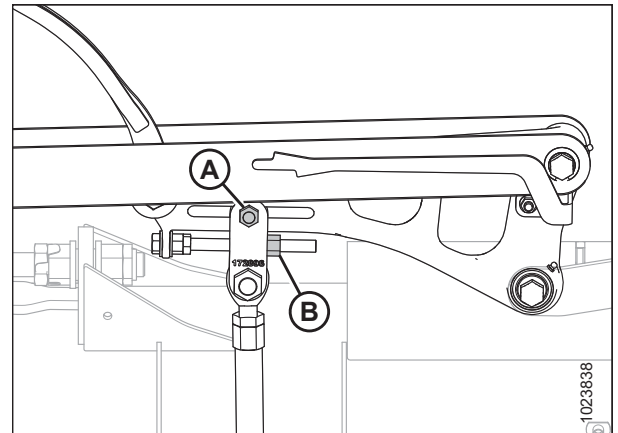

Figure 6.46: Balance Linkage – Left Side

4. If necessary, perform the following adjustments:
  - If the wing is too heavy, turn adjuster bolt (B) clockwise to move clevis (C) outboard (D).
  - If the wing is too light, turn adjuster bolt (B) counterclockwise to move clevis (C) inboard (E).
5. Adjust clevis (C) position if necessary until indicator readings on torque wrench are within 1/2 increment.
6. Tighten nut (A) on clevis bolt.
7. Torque jam nut (F) to 81 Nm (60 lbf-ft).

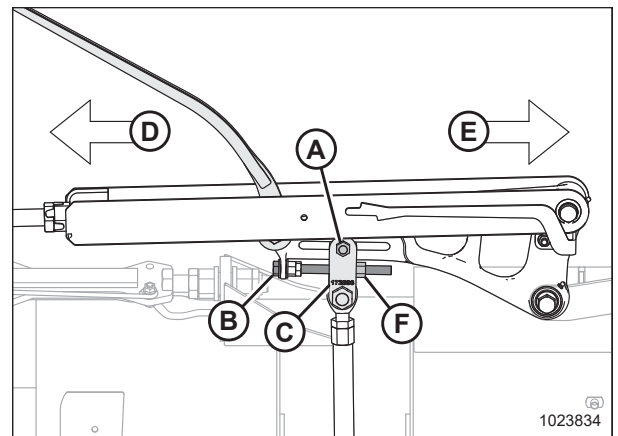

Figure 6.47: Balance Linkage – Left Side

## PERFORMING PREDELIVERY CHECKS

8. Move handle (A) to the upper LOCK position.
9. If lock does not engage, move the wing up and down with torque wrench (B) until it locks. When locked, there will be some movement in the linkage.
10. If the cutterbar is not straight when wings are in lock mode, then further adjustments are required.

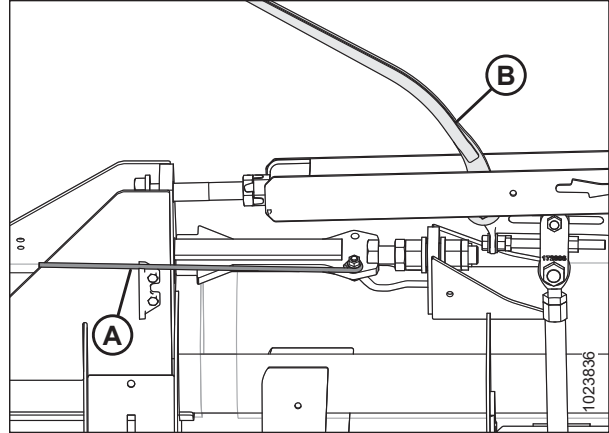

Figure 6.48: Wing Lock in Lock Position

11. Return torque wrench (A) to its storage location on the float module frame.

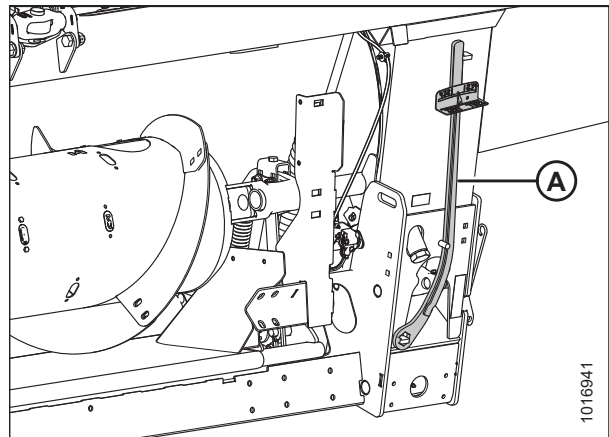

Figure 6.49: Torque Wrench in Storage Location

12. Reinstall linkage cover (A) and secure it with bolt (B).

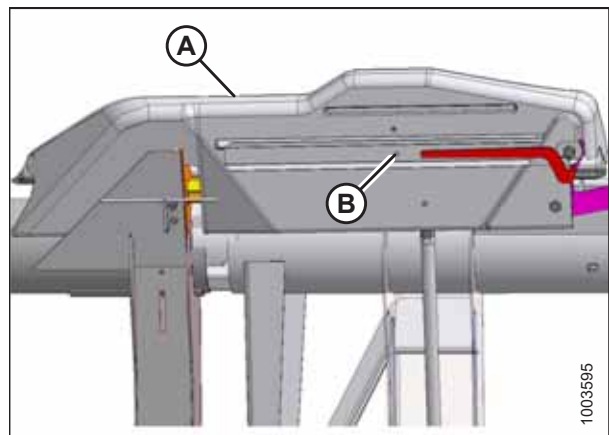

Figure 6.50: Linkage Cover

## 6.13 Reel Clearance to Cutterbar

The minimum clearance between the reel fingers and the cutterbar ensures that the reel fingers do not contact the cutterbar during operation. The clearance is set at the factory, but some adjustment may be necessary before operation.

The finger to guard/cutterbar clearances with reels fully lowered are shown in the table below.

**IMPORTANT:**

Measurements must be taken at **both ends of each reel and at the cutterbar flex locations** with the header in full-frown mode.

**Table 6.3 Finger to Guard/Cutterbar Clearance**

Header Width	Single Reel	Double Reel
	(X) 3 mm (+/- 1/8 in.) at Flex Locations ONLY with Header in Full-Frown Mode	(X) 3 mm (+/- 1/8 in.) at Reel Ends and Flex Locations with Header in Full-Frown Mode
FD125	20 mm (3/4 in.)	—
FD130	—	20 mm (3/4 in.)
FD135	—	20 mm (3/4 in.)
FD140	—	20 mm (3/4 in.)
FD145	—	20 mm (3/4 in.)

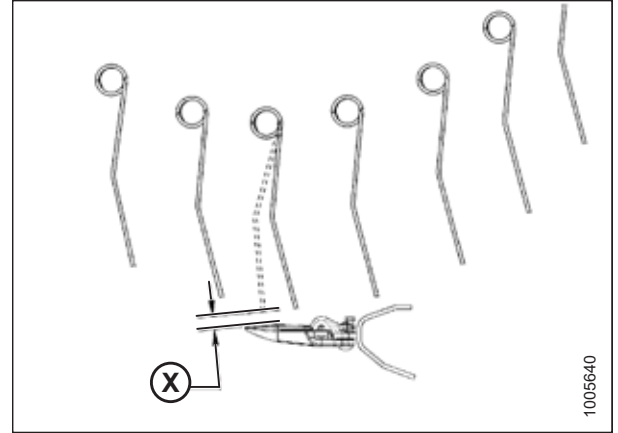

**Figure 6.51: Finger Clearance**

### 6.13.1 Measuring Reel Clearance

**⚠ DANGER**

To avoid bodily injury or death from unexpected start-up or fall of raised machine, always stop engine, remove key, and engage safety props before going under header for any reason.

**⚠ WARNING**

Never start or move the machine until you are sure all bystanders have cleared the area.

1. Start the engine.
2. Lower the header fully on level ground.

## PERFORMING PREDELIVERY CHECKS

3. Move spring handles (A) down to UNLOCK position.

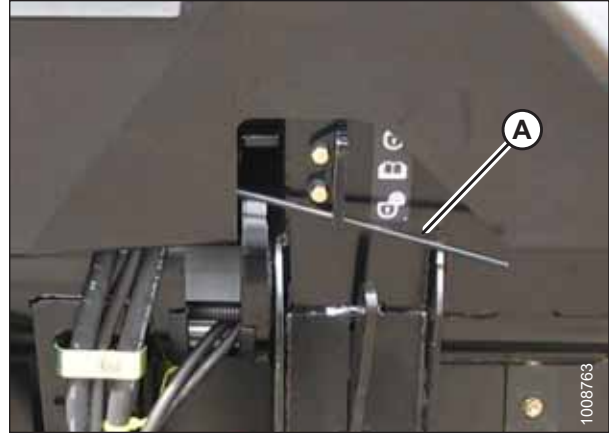

Figure 6.52: Wing Lock in UNLOCK Position

4. Raise header and place two 150 mm (6 in.) blocks (A) under the cutterbar, just inboard of the wing flex points.
5. Lower header fully, allowing it to flex into full frown mode.

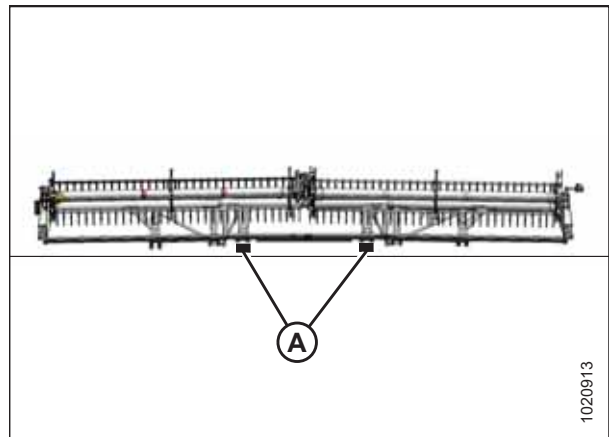

Figure 6.53: FlexDraper® Header Block Locations

6. Set the fore-aft position to the middle position (5) on fore-aft position decal (A).
7. Lower the reel fully.
8. Shut down the engine, and remove the key from the ignition.

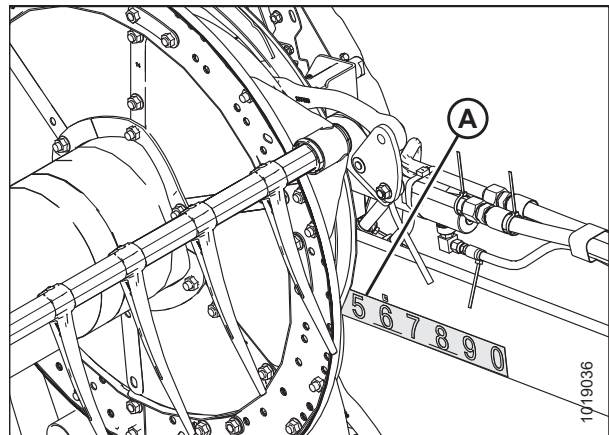

Figure 6.54: Fore-Aft Position

## PERFORMING PREDELIVERY CHECKS

9. Measure clearance (X) between guard (A) and finger (B) at certain measurement locations. For clearance specifications, refer to [6.13 Reel Clearance to Cutterbar, page 161](#).

For the measurement locations, refer to:

- [Figure 6.56, page 163](#) – FlexDraper® Header

**NOTE:**

The reel is factory-set to provide more clearance at the center of the reel than at the ends (frown) to compensate for reel flexing.

**NOTE:**

When measuring reel clearance at the center of a double-reel header, measure the lowest reel.

**Single Reel:** Measure reel clearance at both hinge points (A).

**Double Reel:** Measure reel clearance at both hinge points (A) and at outer ends (B) of the reels.

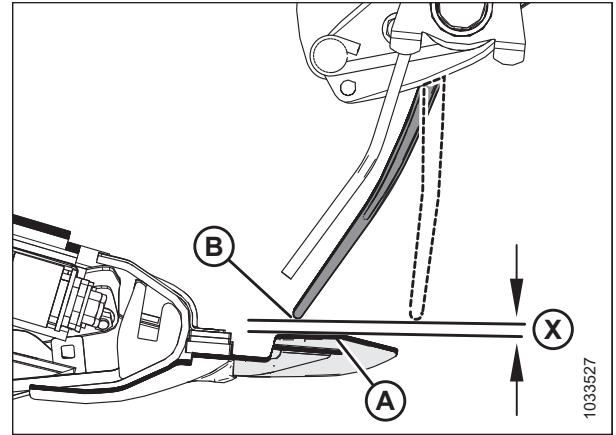

Figure 6.55: Clearance

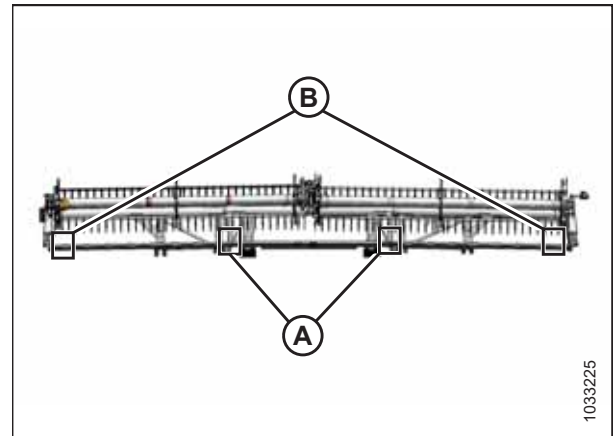

Figure 6.56: Measurement Locations – Double Reel Shown

10. Adjust the reel clearance, if required. For instructions, refer to [6.13.2 Adjusting Reel Clearance, page 163](#).

### 6.13.2 Adjusting Reel Clearance

**⚠ DANGER**

To avoid bodily injury or death from unexpected start-up or fall of raised machine, always stop engine, remove key, and engage safety props before going under header for any reason.

1. Raise the reel fully.
2. Shut down the engine, and remove the key from the ignition.
3. Engage the reel safety props. For instructions, refer to [10.1.1 Engaging Reel Safety Props, page 377](#).

## PERFORMING PREDELIVERY CHECKS

4. Adjust the outboard reel arm lift cylinders to set the clearance at the outboard ends of the reel as follows:
  - a. Loosen bolt (A).
  - b. Turn cylinder rod (B) out of clevis to raise reel and increase clearance to cutterbar, or turn cylinder rod into clevis to lower reel and decrease clearance.
  - c. Tighten bolt (A).
  - d. Repeat at opposite side.

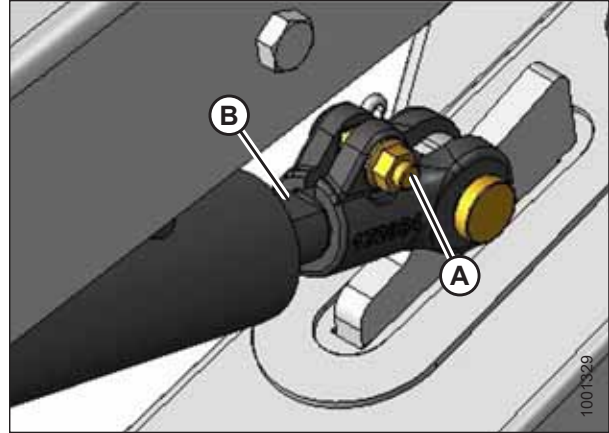

Figure 6.57: Outside Reel Arm

5. **Double reel:** adjust center arm lift cylinder stop (A) to change clearance at inboard ends of reels and clearance at flex points as follows:

- a. Loosen nut (B).

**NOTE:**

To make adjustment easier, lower reel onto the safety props after loosening nut (B).

- b. Turn nut (C) counterclockwise to raise reel and increase clearance to cutterbar, or clockwise to lower reel and decrease clearance.
- c. Tighten nut (B).

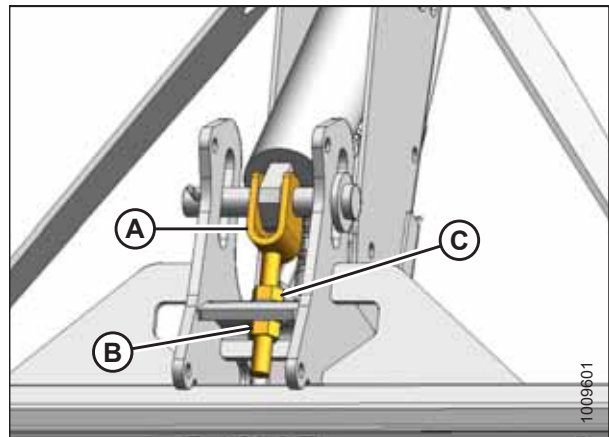

Figure 6.58: Underside of Center Arm

6. Check measurements and, if necessary, repeat adjustment procedures.
7. Move the reel back to ensure the steel end fingers do **NOT** contact the deflector shields.
8. If contact occurs, adjust the reel upward to maintain the clearance at all reel fore-aft positions. If contact cannot be avoided after adjusting the reel, trim the steel end fingers to obtain proper clearance.
9. Periodically check for evidence of contact during operation, and adjust clearance as required.
10. Shut down the engine, and remove the key from the ignition.



## 6.14 Adjusting Auger to Pan Clearance

### WARNING

To avoid injury or death from unexpected start-up of machine, always stop the engine and remove the key from the ignition before leaving the operator's seat for any reason.

#### IMPORTANT:

Maintain an appropriate distance between the auger and the auger pan. Too little clearance may result in the fingers or flighting contacting and damaging the feed draper or pan when operating the header at certain angles. Look for evidence of contact when greasing the float module.

1. Extend the center-link to the steepest header angle, and position the header 150–254 mm (6–10 in.) off the ground.
2. Shut down the engine, and remove the key from the ignition.
3. Ensure the float lock linkage is on the down stops (washer [A] cannot be moved) at both locations.

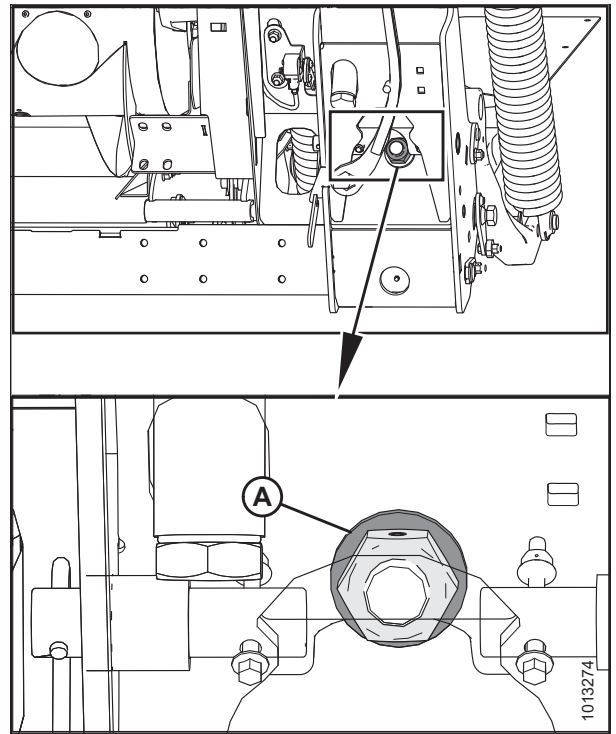

Figure 6.59: Float Lock

## PERFORMING PREDELIVERY CHECKS

- Before adjusting the auger to pan clearance, check the auger float position to determine how much clearance is required:
  - If bolt head (A) is closest to floating symbol (B), the auger is in the floating position.

### IMPORTANT:

Make sure bolts (A) are set at the same location on both ends of the header to prevent damaging the machine during operation.

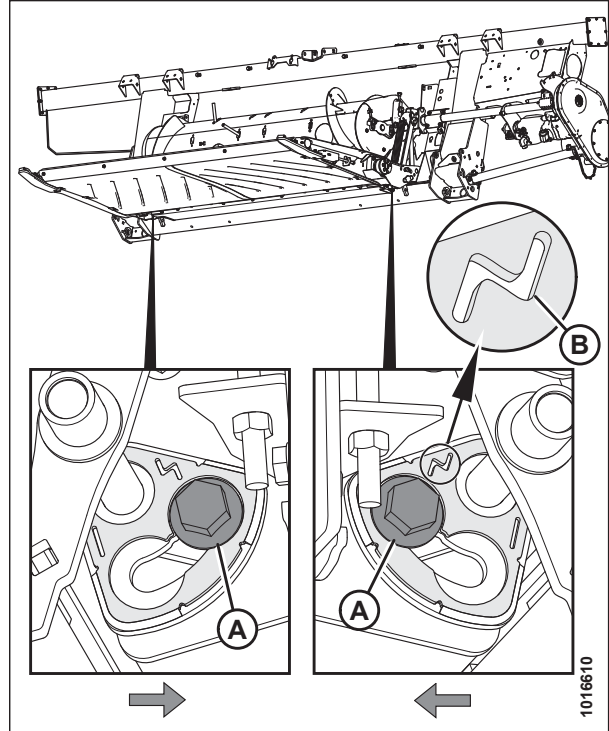

Figure 6.60: Floating Position

- If bolt head (A) is closest to fixed symbol (B), the auger is in the fixed position.

### IMPORTANT:

Make sure bolts (A) are set at the same location on both ends of the header to prevent damaging the machine during operation.

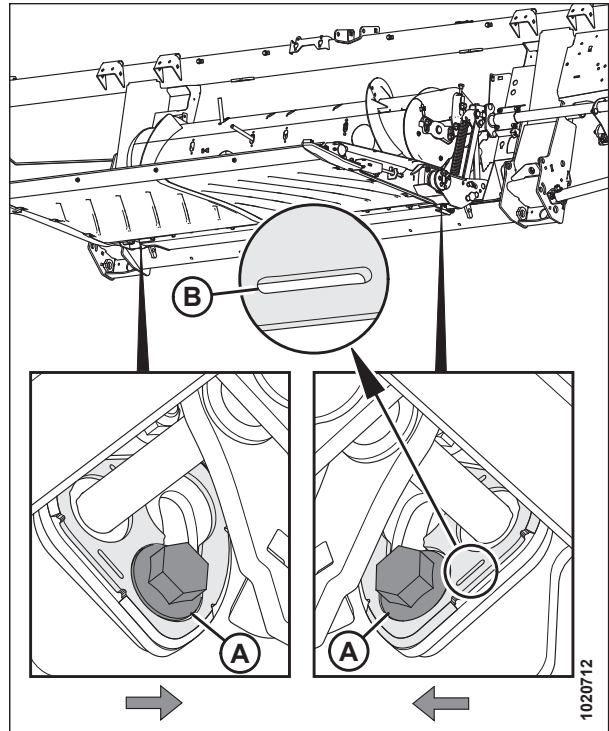

Figure 6.61: Fixed Position

## PERFORMING PREDELIVERY CHECKS

5. Loosen two nuts (B) and rotate the auger to position the flighting over the feed pan.
6. Turn bolt (A) clockwise to increase clearance (C); turn bolt (A) counterclockwise to decrease clearance (C).
  - If the feed auger is in the fixed position, set clearance to 22–26 mm (7/8–1.0 in.).
  - If the feed auger is in the floating position, set clearance to 11–15 mm (7/16–5/8 in.).

**NOTE:**

The clearance increases between 25–40 mm (1–1 1/2 in.) when the center-link is fully retracted.

7. Repeat Steps 5, [page 167](#) and 6, [page 167](#) for the opposite end of the auger.

**IMPORTANT:**

Adjusting one side of the auger can affect the other side. Always double-check both sides of the auger after making final adjustments.

8. Tighten nuts (B) on both ends of the feed auger. Torque the nuts to 93–99 Nm (68–73 lbf·ft).
9. Rotate the drum and double-check clearances.

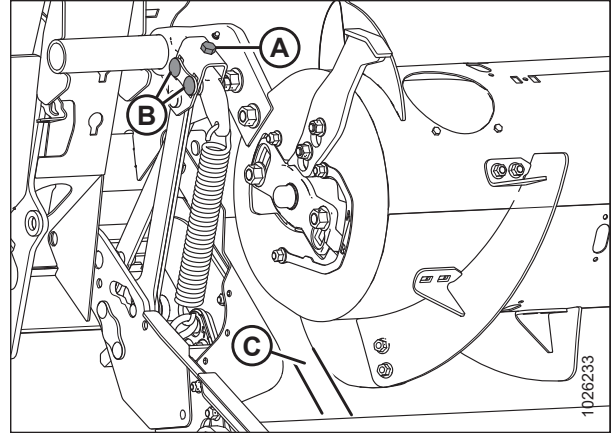

Figure 6.62: Auger Clearance

## 6.15 Adjusting Draper Tension

The drapers are tensioned at the factory and rarely need adjustment. If adjustment is required, tension the drapers just enough to prevent slipping and to keep the draper from sagging below the cutterbar. Adjust drapers on both sides of the header.

### DANGER

To avoid bodily injury or death from unexpected start-up or fall of raised machine, always stop engine, remove key, and engage safety props before going under machine for any reason.

1. Ensure white indicator bar (A) is at the halfway point in the window.

### WARNING

Check to be sure all bystanders have cleared the area.

2. Start the engine and fully raise the header.
3. Shut down the engine, and remove the key from the ignition.
4. Engage the header safety props.

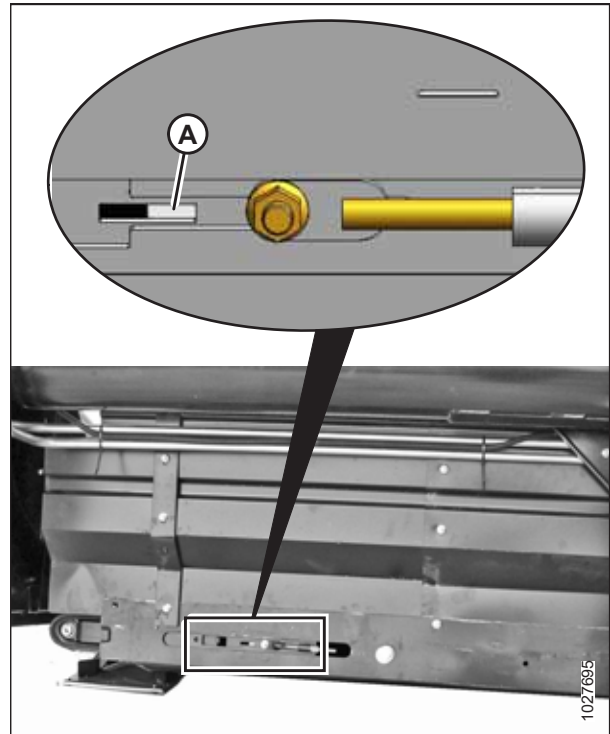

Figure 6.63: Left Tension Adjuster Shown – Right Opposite

5. Ensure the draper guide (the rubber track on the underside of the draper) is properly engaged in groove (A) on the drive roller.

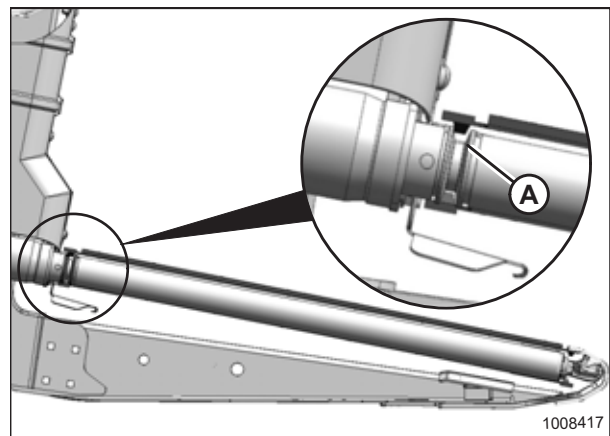

Figure 6.64: Drive Roller

## PERFORMING PREDELIVERY CHECKS

6. Ensure idler roller (A) is between draper guides (B).

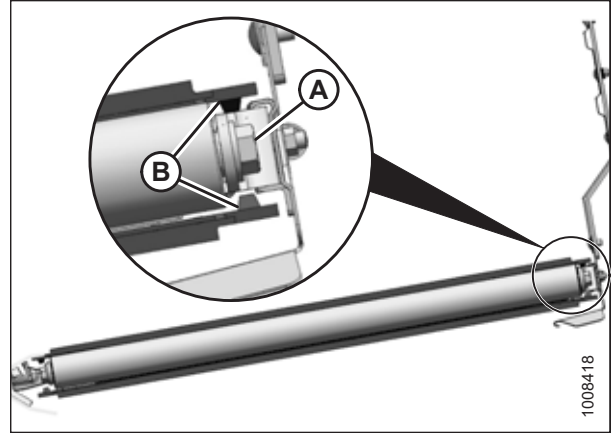

Figure 6.65: Idler Roller

### IMPORTANT:

Do **NOT** adjust nut (C). This nut is used for draper alignment only.

7. To loosen draper tension:
  - Turn adjuster bolt (A) counterclockwise. White indicator bar (B) will move outboard in the direction of arrow (D) to indicate that the draper is loosening. Loosen until the white indicator bar is at the halfway point in the window.
8. To tighten draper tension:
  - Turn adjuster bolt (A) clockwise. White indicator bar (B) will move inboard in direction of arrow (E) to indicate that the draper is tightening. Tighten until the white indicator bar is at the halfway point in the window.

### IMPORTANT:

To avoid premature failure of the draper, draper rollers, and/or tightener components, do **NOT** operate if the white bar is not visible.

### IMPORTANT:

To prevent scooping dirt, ensure the draper is tight enough that it does not sag below the point where the cutterbar contacts the ground.

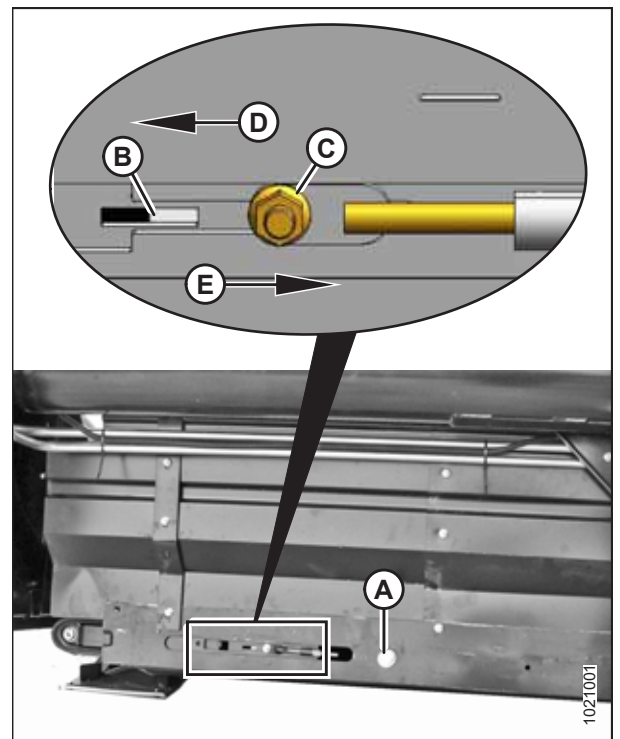

Figure 6.66: Left Tension Adjuster Shown – Right Opposite

## 6.16 Checking and Adjusting Draper Seal

Maintain the deck height such that the draper runs just below the cutterbar.

**IMPORTANT:**

New factory-installed drapers are pressure and heat checked at the factory. The gap (deck seal) between draper and cutterbar is set to 0–3 mm (0.00–0.12 in.) at the factory to prevent material from entering into the side drapers and stalling them. When installing new drapers, however, it is **NEVER** acceptable for the gap to be less than 1 mm (0.04 in.) because new drapers are very tacky and there can be a buildup of powder coat on the underside of the cutterbar that can cause excessive drag and extremely high running pressure.

1. With the header in working position, check that clearance (A) between draper (B) and cutterbar (C) is 0–3 mm (0.00–0.12 in.).
  - If the deck height is acceptable, skip the remaining steps and proceed to [6.17 Lubricating Header, page 173](#).
  - If the deck height is **NOT** acceptable, adjust the seal as described in the following steps:

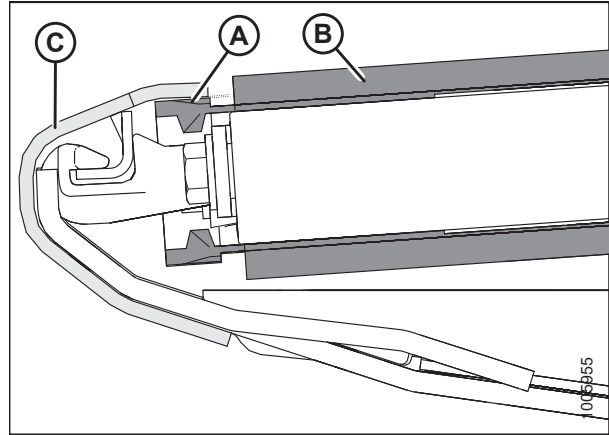

Figure 6.67: Draper Seal

2. Take measurement at deck supports (A) with the header in working position. Depending on the header size, there are between two and eight supports per deck.
3. Loosen the draper tension. For instructions, refer to [6.15 Adjusting Draper Tension, page 168](#).

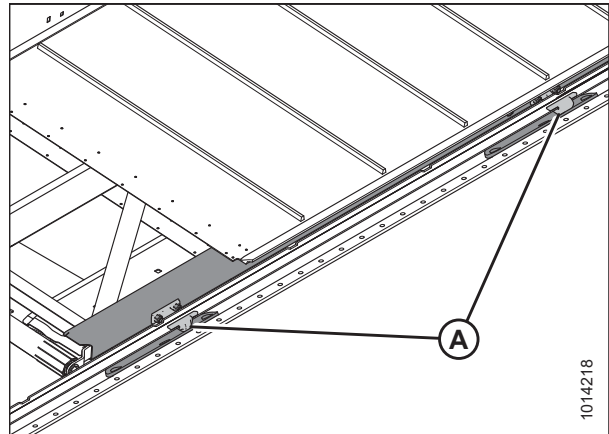

Figure 6.68: Draper Deck Supports

## PERFORMING PREDELIVERY CHECKS

4. Lift front edge of draper (A) past cutterbar (B) to expose the deck support.
5. Measure and note the thickness of the draper belt.

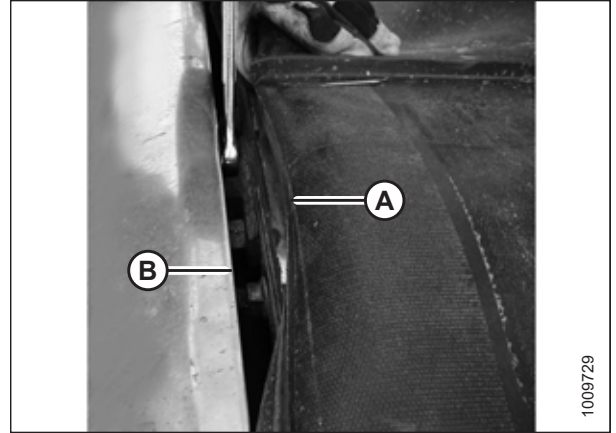

Figure 6.69: Deck Adjustment

6. Loosen two lock nuts (A) on deck support (B) one half-turn **ONLY**.

### NOTE:

The deck is shown with the draper removed. The number of deck supports (B) is determined by the header width as follows:

- **FD125:** Six supports
- **FD130 and FD135:** Eight supports
- **FD140:** Ten supports
- **FD145:** Twelve supports

7. Tap deck (C) with a hammer to lower the deck relative to the deck supports. Tap deck support (B) using a punch to raise the deck relative to the deck supports.
8. Locate a gauge that is the same thickness as the draper belt, plus 1 mm (0.04 in.). Slide the thickness gauge along deck (A) under the cutterbar in order to properly set the gap.
9. To create a seal, adjust deck (A) so that clearance (B) between cutterbar (C) and deck is the same thickness as the draper belt plus 1 mm (0.04 in.).

### NOTE:

When checking clearance at either roller, measure from the roller tube, **NOT** the deck.

10. Tighten deck support hardware (D).
11. Recheck gap (B) with thickness gauge. For instructions, refer to Step 8, page 171.
12. Tension the draper. For instructions, refer to [6.15 Adjusting Draper Tension, page 168](#).

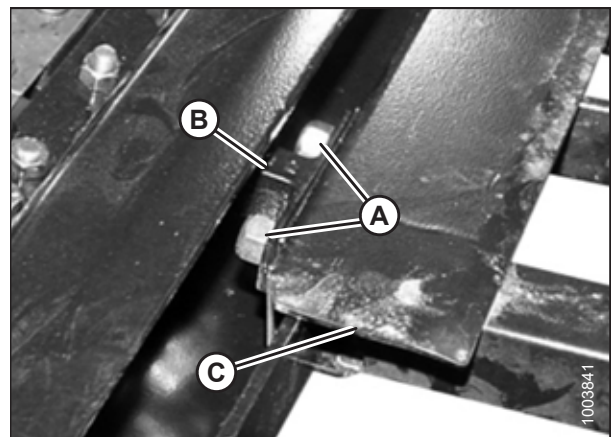

Figure 6.70: Deck Support

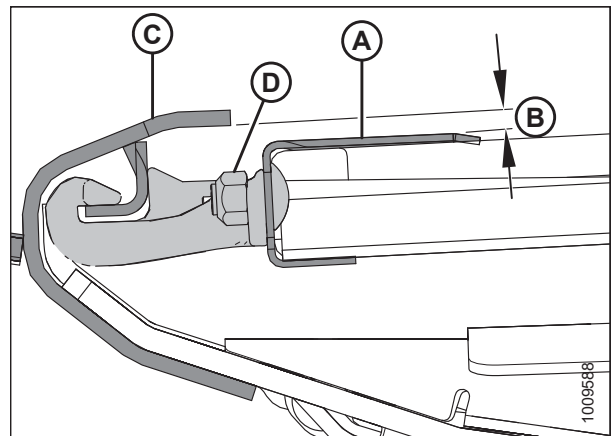

Figure 6.71: Deck Support

## PERFORMING PREDELIVERY CHECKS

13. If required, adjust backsheet deflector (A) by loosening nut (D) and moving the deflector until there is a 1–7 mm (0.04–0.28 in.) gap (C) between draper (B) and the deflector.

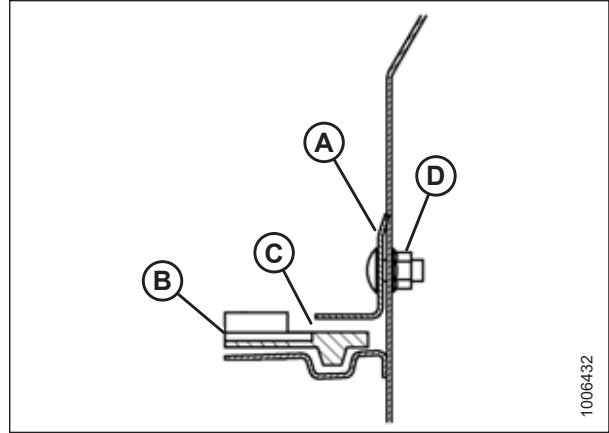

Figure 6.72: Backsheet Deflector



## 6.17 Lubricating Header

Table 6.4 Recommended Lubricant

Specification	Description	Use
SAE multipurpose	High temperature, extreme pressure (EP2) performance with 1% max molybdenum disulphide (NLGI Grade 2) lithium base	As required unless otherwise specified
SAE multipurpose	High temperature, extreme pressure (EP) performance with 10% max molybdenum disulphide (NLGI Grade 2) lithium base	Driveline slip-joints

### 6.17.1 Greasing Procedure

Greasing points are identified on the machine by decals showing a grease gun and grease interval in hours of operation. Grease point layout decals are located on the header and on the right side of the float module.

#### WARNING

To avoid injury or death from unexpected start-up of machine, always stop the engine and remove the key from the ignition before leaving the operator's seat for any reason.

1. Shut down the engine, and remove the key from the ignition.
2. Wipe grease fitting with a clean cloth before greasing to avoid injecting dirt and grit.

#### IMPORTANT:

Use clean, high-temperature, extreme-pressure grease only.

3. Inject grease through fitting with grease gun until grease overflows fitting (except where noted).
4. Leave excess grease on fitting to keep out dirt.
5. Replace any loose or broken fittings immediately.
6. Remove and thoroughly clean any fitting that will not take grease. Also clean lubricant passageway. Replace fitting if necessary.

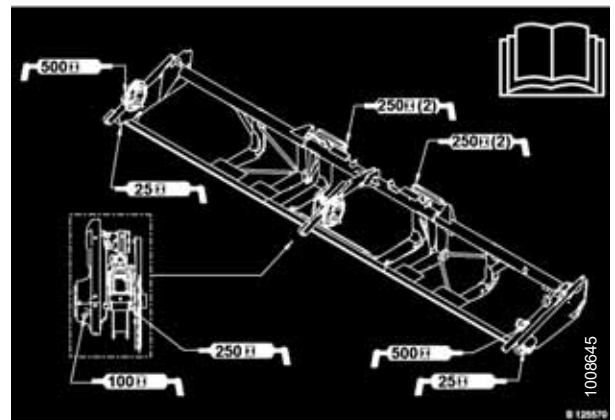

Figure 6.73: FD1 Series Grease Point Decal

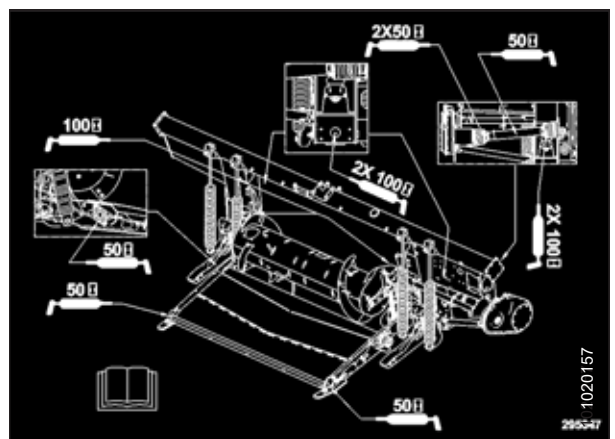

Figure 6.74: FM100 Grease Point Decal

## 6.17.2 Lubrication Points

### Knifehead

#### IMPORTANT:

Overgreasing can cause the knife to bend and make contact with the guards closest to the knifehead. Check for signs of excessive heating on first few guards after greasing. If required, relieve some pressure by removing the grease fitting.

- To prevent binding and/or excessive wear caused by knife pressing on guards, do **NOT** overgrease knifehead (A).
- Apply only 1–2 pumps of grease with a grease gun, or just until the knifehead starts to move away from the arm. Do **NOT** use an electric grease gun.
- If more than 6–8 pumps of the grease gun are required to fill the cavity, replace the seal in the knifehead.
- Check for signs of excessive heating on first few guards after greasing. If required, relieve pressure by pressing check-ball in grease fitting.

#### NOTE:

Use high temperature extreme pressure (EP2) performance with 1% max molybdenum disulphide (NLGI Grade 2) lithium base grease unless otherwise specified.



**Figure 6.75: Knifehead**

Single Knife – One Place

Double Knife – Two Places

PERFORMING PREDELIVERY CHECKS

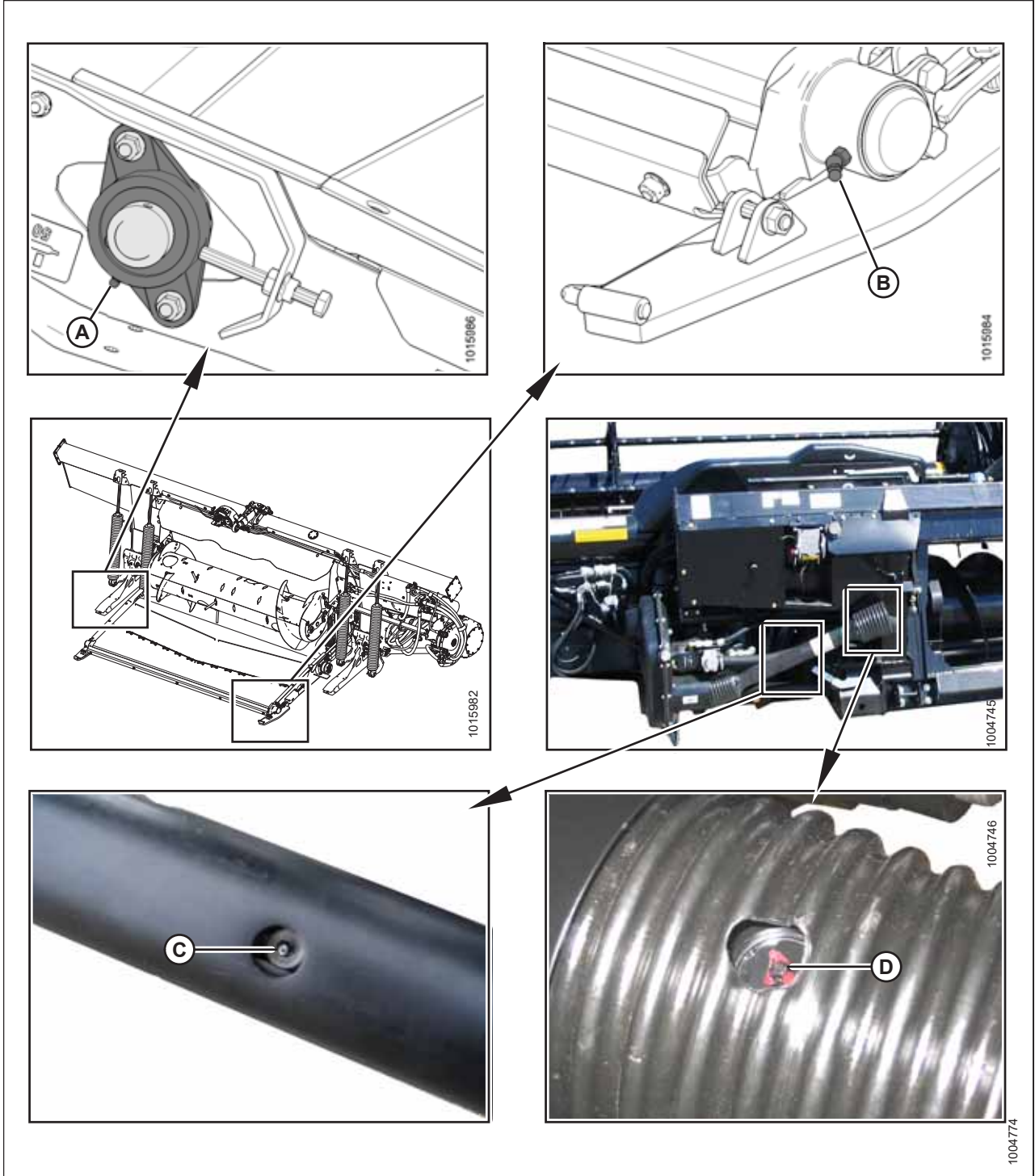

Figure 6.76: Drive Roller Bearing, Idler Roller, Slip Joint, and Driveline Universal

A - Drive Roller Bearing

B - Idler Roller (Both Sides)

C - Driveline Slip Joint<sup>3</sup>

D - Driveline Universal (Two Places)

3. 10% moly grease is recommended for the driveline slip joint.

PERFORMING PREDELIVERY CHECKS

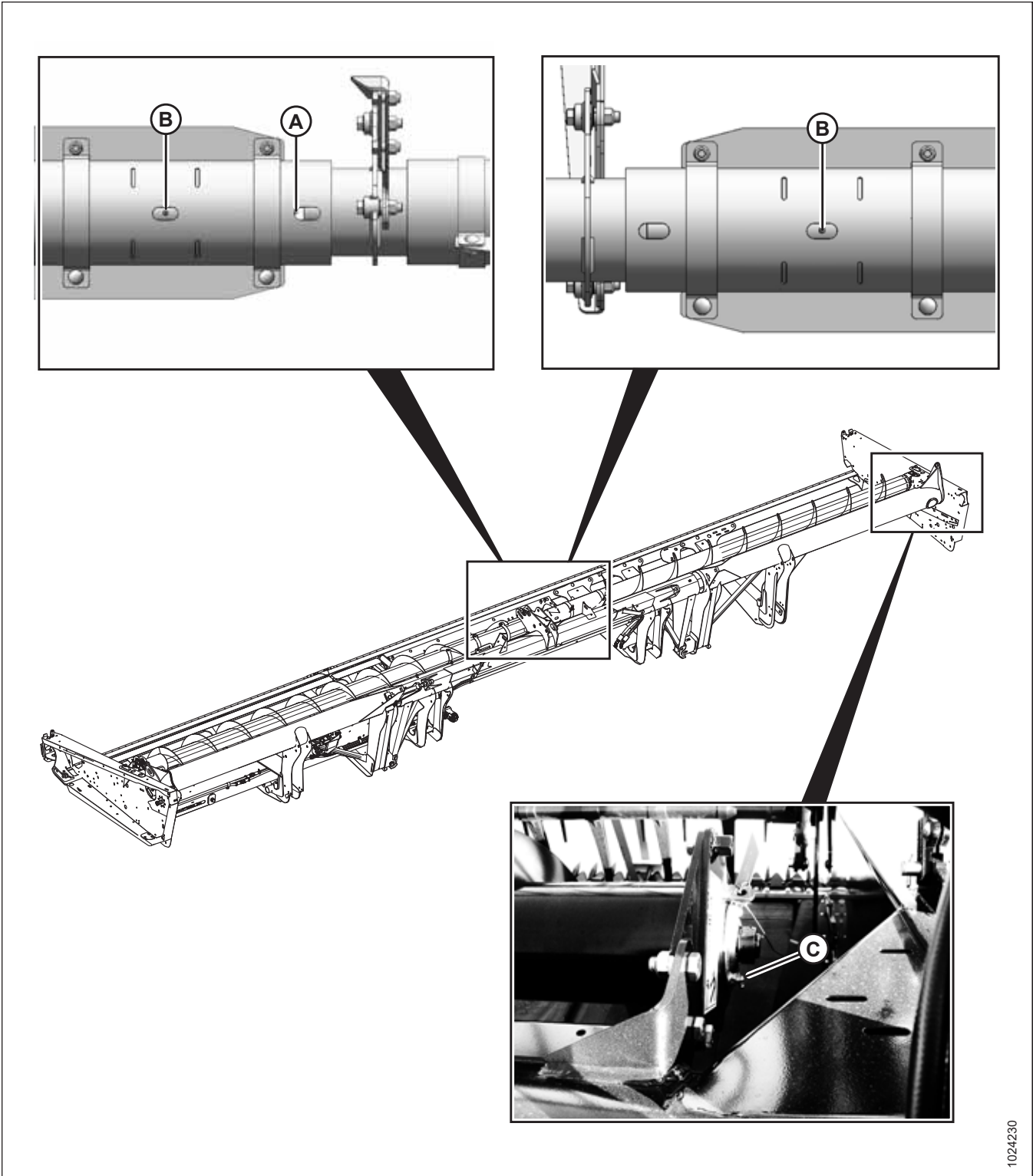

1024230

Figure 6.77: Upper Cross Auger

A - Upper Cross Auger U-Joint and Bearing

B - Upper Cross Auger Bearing (One Place)

C - Upper Cross Auger (One Place)

PERFORMING PREDELIVERY CHECKS

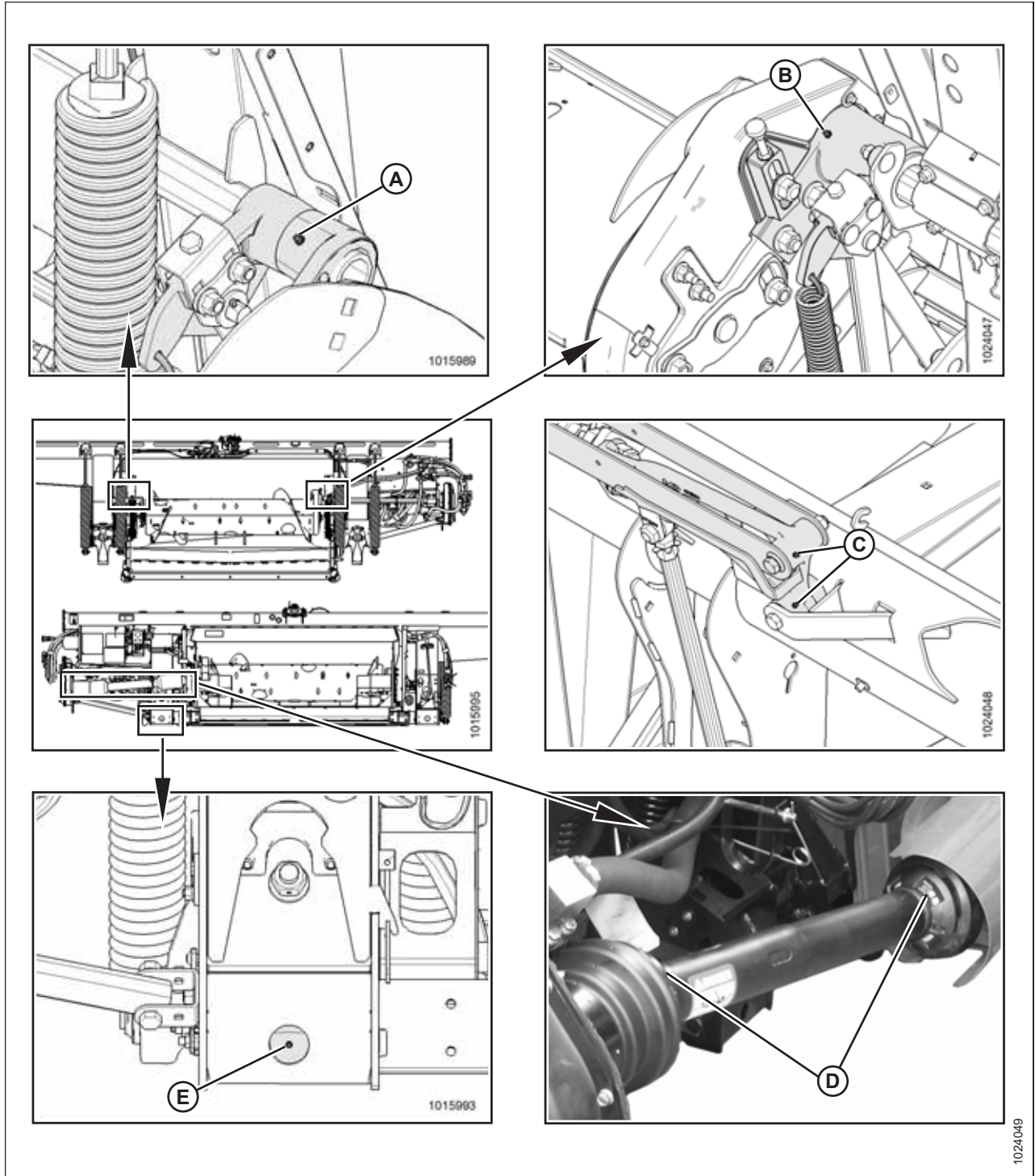

Figure 6.78: Float Pivot, Driveline Guard, Flex Linkage, and Auger Pivot

A - Auger Pivot (First Place)  
D - Driveline Guard (Two Places)

B - Auger Pivot (Second Place)  
E - Float Pivot (Two Places)

C - Flex Linkage (Two Places) (Both Sides)

PERFORMING PREDELIVERY CHECKS

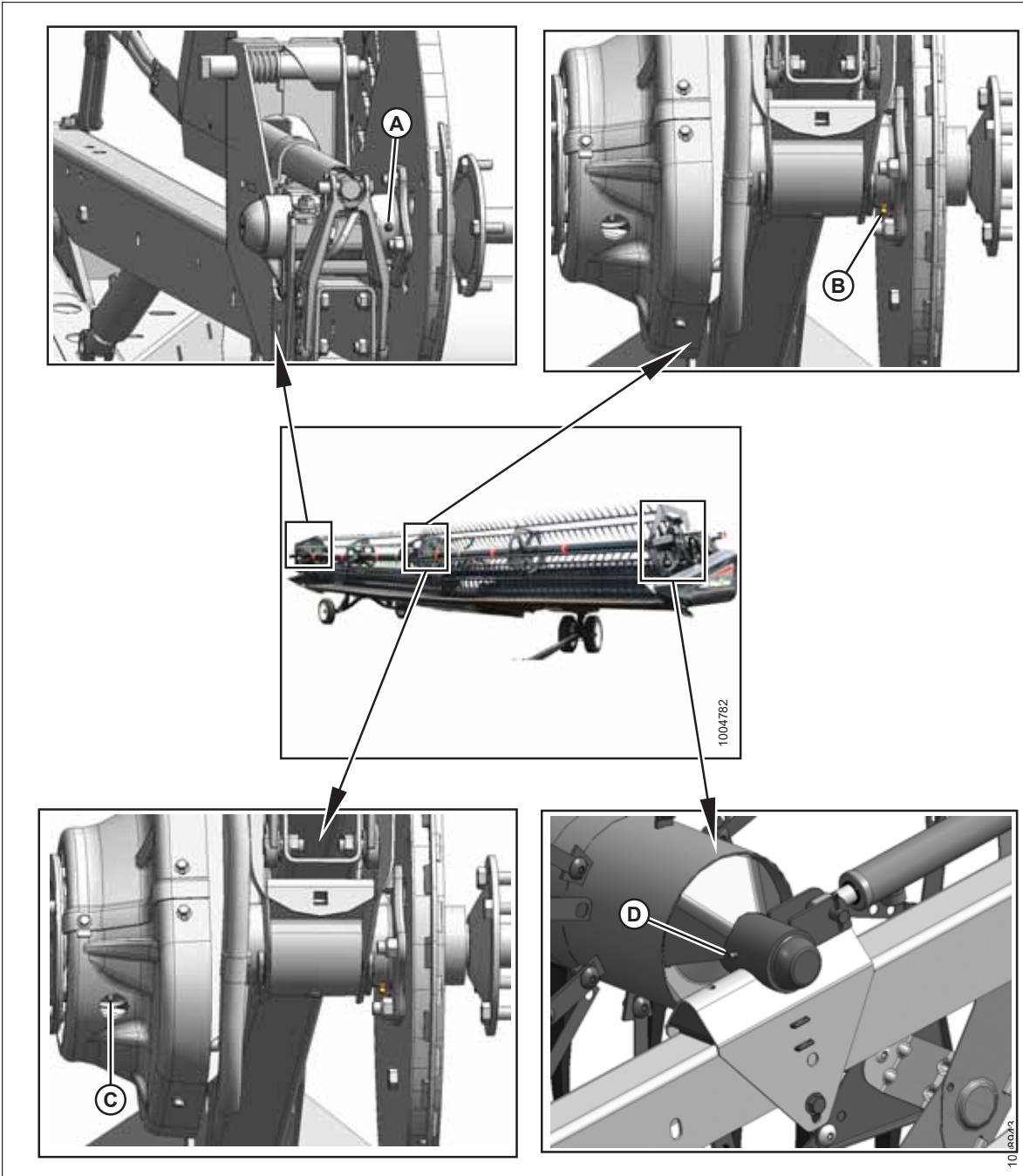

Figure 6.79: Reel Shaft Bearings

A - Reel Shaft Right Bearing (One Place)  
C - Reel Universal (One Place)

B - Reel Center Bearing (One Place)  
D - Reel Shaft Left Bearing (One Place)

PERFORMING PREDELIVERY CHECKS



Figure 6.80: Rear Wheel Axle, Wheel Bearings, Frame/Wheel Pivot, and Front Wheel Pivot

A - Wheel Bearings (Four Places)

B - Front Wheel Pivot (One Place)

C - Frame/Wheel Pivot (One Place) Both Sides

## 6.18 Checking and Adjusting Endshields

Endshields are subject to expansion or contraction caused by large temperature variations. The position of the top pin and lower latch can be adjusted to compensate for dimensional changes.

### Checking the endshield:

1. Check gap (X) between the front end of the shields and the header frame and compare to the values in Table 6.5, page 180.

Table 6.5 Endshield Gap at Various Temperatures

Temperature in °C (°F)	Gap (X) mm (in.)
7 (45)	13–18 (1/2–23/32)
18 (65)	10–15 (3/8–19/32)
29 (85)	7–12 (9/32–15/32)
41 (105)	4–9 (5/32–11/32)

2. If the endshield gap is correct, proceed to the next procedure. If adjustment is required, proceed to Step 1, page 180.

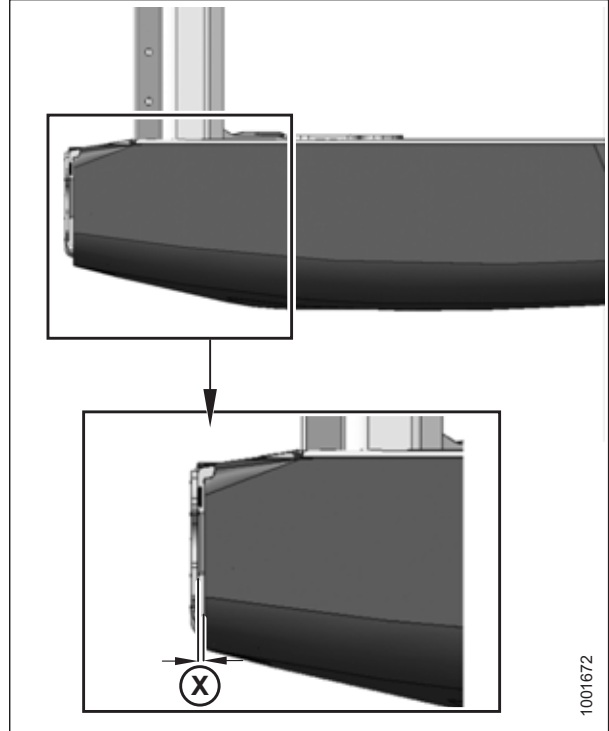

Figure 6.81: Gap between Endshield and Header Frame

### Opening the endshield:

1. To unlock the shield, push release lever (A) located on the backside of the endshield.
2. Pull endshield open using handle depression (B).

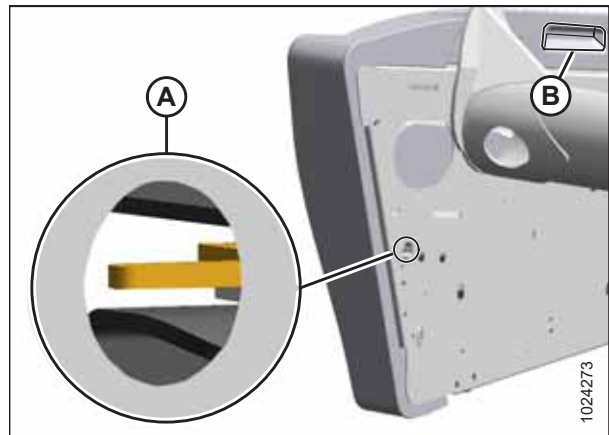

Figure 6.82: Left Endshield



## PERFORMING PREDELIVERY CHECKS

3. Pull endshield at handle depression (A). Endshield is retained by hinge tab (B) and will open in direction (C).

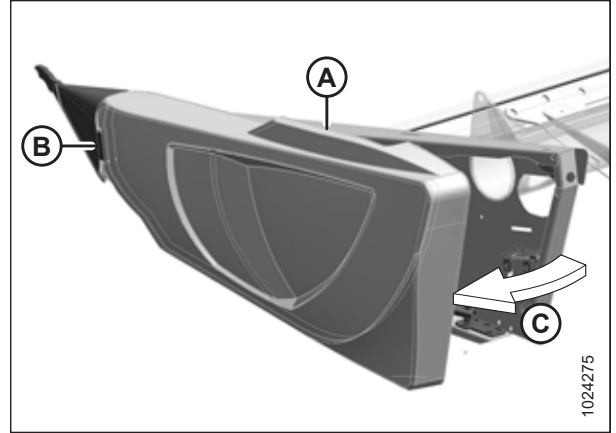

Figure 6.83: Left Endshield

4. Pull the endshield free of hinge tab (A) if additional clearance is required, and swing shield towards the rear of the header.
5. Engage safety catch (B) on hinge arm to secure the shield in fully-open position.

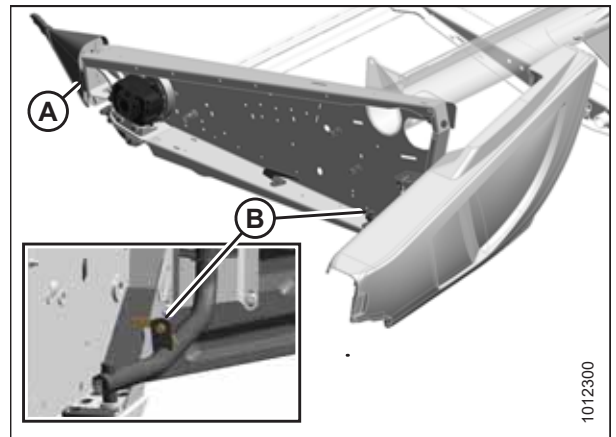

Figure 6.84: Left Endshield

### ***Adjusting the endshield gap:***

1. Loosen four bolts (A) on support tube bracket (B).

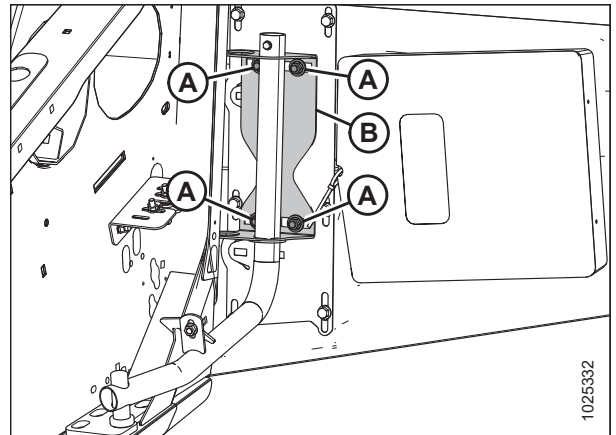

Figure 6.85: Left Endshield Support Tube

## PERFORMING PREDELIVERY CHECKS

2. Loosen three bolts (A) on latch assembly (B).
3. Adjust latch assembly (B) to achieve the desired gap between the front end of the shield and the header frame. Refer to Table 6.5, page 180 for the recommended endshield gap at various temperatures.
4. Tighten three bolts (A) on the latch assembly to 27 Nm (20 lbf-ft).

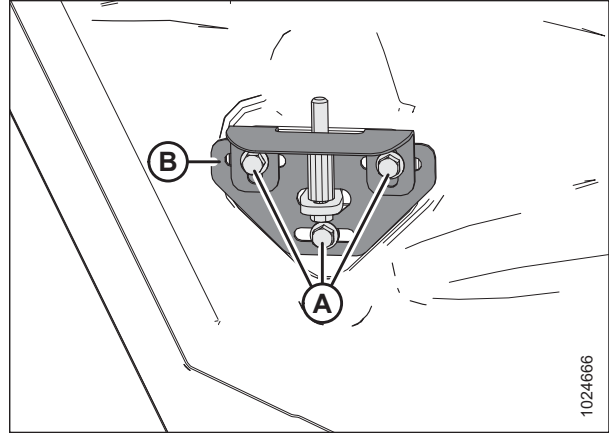

Figure 6.86: Left Endshield Latch Assembly

5. Tighten four bolts (A) on support tube bracket (B) to 31 Nm (23 lbf-ft).

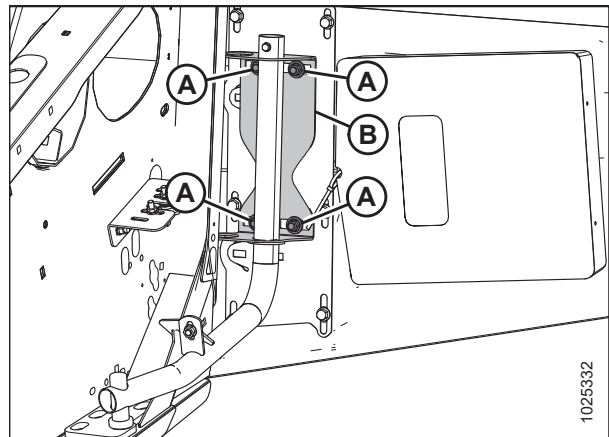

Figure 6.87: Left Endshield Support Tube

### ***Closing the endshield:***

1. Disengage lock (B) to allow endshield to move.
2. Insert front of endshield behind hinge tab (A) and into divider cone.

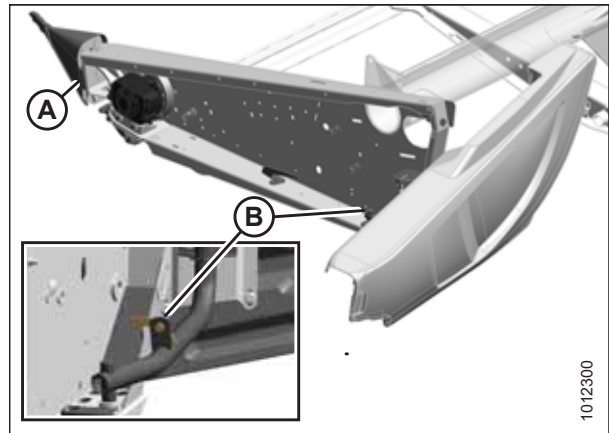

Figure 6.88: Left Endshield

## PERFORMING PREDELIVERY CHECKS

3. Swing endshield in direction (A) into closed position.  
Engage lock with a firm push.
4. Verify that endshield is locked.

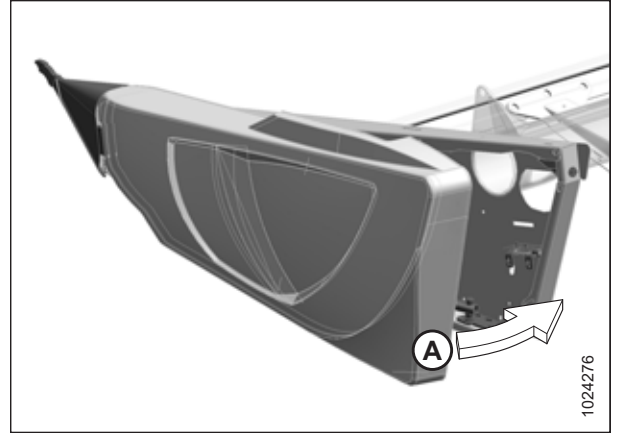

Figure 6.89: Left Endshield

## 6.19 Checking Manuals

Check the manual case contents. The manual case is located inside the left endshield.

1. Open the left endshield. Remove the cable tie on manual case (A).
2. Confirm that the case contains the following manuals:
  - FD1 Series FlexDraper® Operator's Manual
  - FD1 Series FlexDraper® Quick Card
  - FD1 Series FlexDraper® with FM100 Float Module Parts Catalog
3. Close the case and endshield.

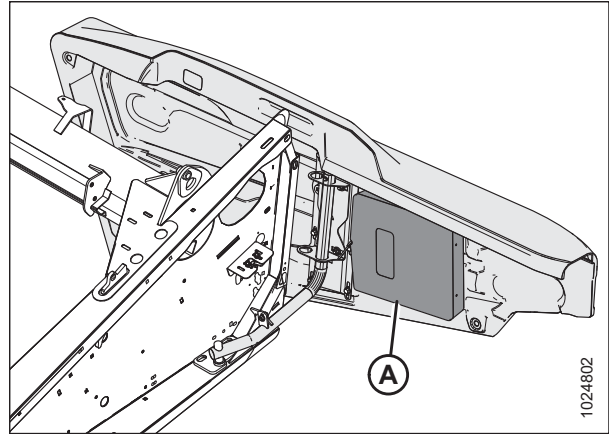

Figure 6.90: Manual Case

# Chapter 7: Setting up Auto Header Height Control

## 7.1 Auto Header Height Control

MacDon's auto header height (AHHC) control feature works in conjunction with the AHHC option available on certain combine models.

A sensor is installed in float indicator box (A) on the FM100 Float Module. This sensor sends a signal to the combine allowing it to maintain a consistent cutting height and an optimum float as the header follows ground contours. A lateral tilt two-sensor system is also available as an optional kit.

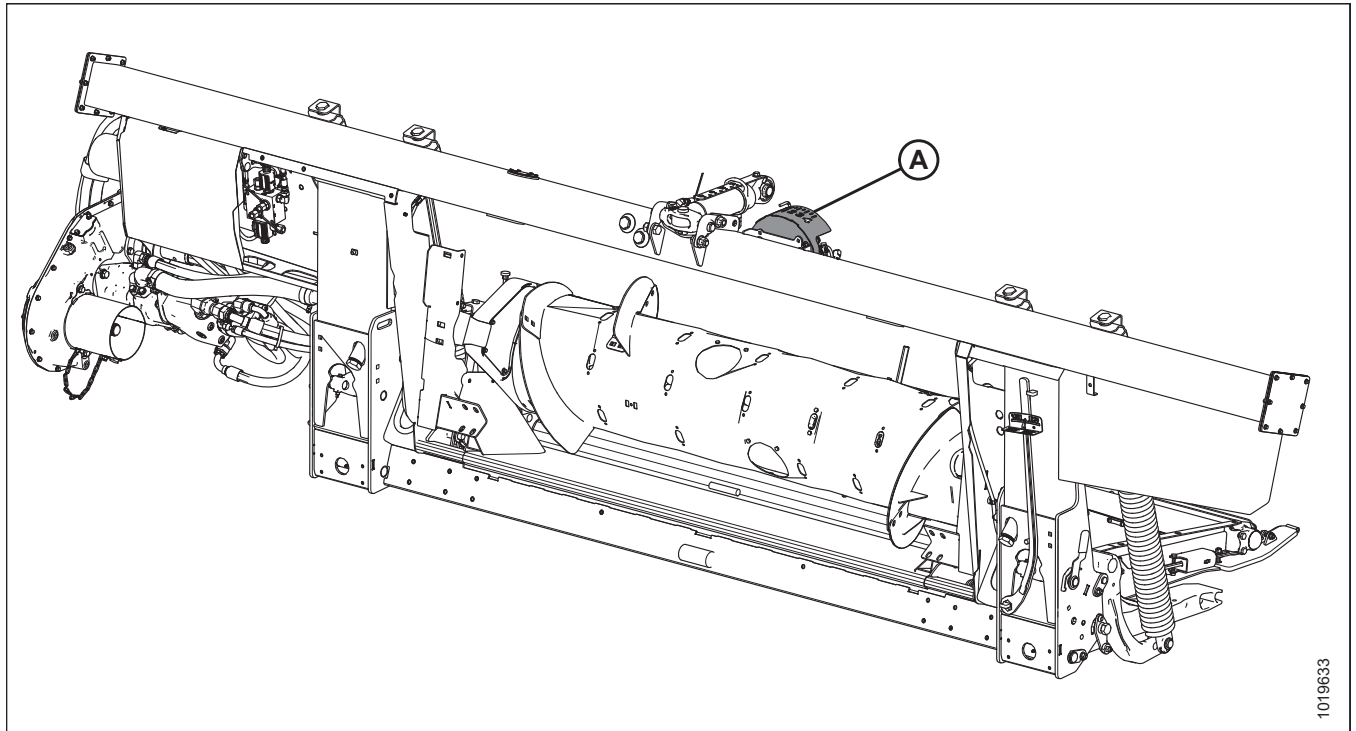

**Figure 7.1: FM100 Float Module**

FM100 Float Modules are factory-equipped for AHHC; however, before using the AHHC feature, you must do the following:

1. Ensure that the AHHC sensor's output voltage range is appropriate for the combine. For more information, refer to [7.1.3 Sensor Output Voltage Range – Combine Requirements, page 187](#).
2. Prepare the combine to use the AHHC feature (applies only to some combine models—refer to the following instructions for your combine).
3. Calibrate the AHHC system so that the combine can correctly interpret data from the height sensor on the float module (refer to the following instructions for your combine).

**NOTE:**

Once calibration is complete, you are ready to use the AHHC feature in the field. Individual combine settings can improve AHHC performance (refer to your combine instruction manual).

Refer to the following instructions for your specific combine model:

- [7.1.4 AGCO IDEAL™ Series Combines, page 197](#)
- [7.1.5 Case IH 5088/6088/7088 Combines, page 209](#)
- [7.1.7 Case IH 7010/8010, 120, 230, 240, and 250 Series Combines, page 220](#)

## SETTING UP AUTO HEADER HEIGHT CONTROL

- [7.1.8 Challenger and Massey Ferguson 6 and 7 Series Combines, page 235](#)
- [7.1.9 CLAAS 500 Series Combines, page 242](#)
- [7.1.10 CLAAS 600 and 700 Series Combines, page 251](#)
- [7.1.12 Gleaner R65/R66/R75/R76 and S Series Combines, page 271](#)
- [7.1.13 Gleaner S9 Series Combines, page 281](#)
- [7.1.14 John Deere 60 Series Combines, page 295](#)
- [7.1.15 John Deere 70 Series Combines, page 302](#)
- [7.1.16 John Deere S and T Series Combines, page 309](#)
- [7.1.18 New Holland Combines – CR/CX Series – 2014 and Prior, page 339](#)
- [7.1.19 New Holland Combines – CR Series – 2015 and Later, page 349](#)

### 7.1.1 Sensor Operation

The position sensors supplied with the auto header height control (AHHC) system are hall-effect sensors. Normal operating signal voltages for the sensors fall between 10% (0.5 VDC) and 90% (4.5 VDC). An increase in sensor voltage correlates to a decrease in ground pressure, or if you are cutting off the ground on gauge wheels, an increase in the header cut height.

Sensor errors result in a 0 V signal, indicating a faulty sensor, incorrect supply voltage, or a damaged wiring harness.

### 7.1.2 Troubleshooting Auto Header Height / Float Indicator

Use [Table 7.1, page 187](#) and [Figure 7.2, page 186](#) to determine the recommended repair procedure:

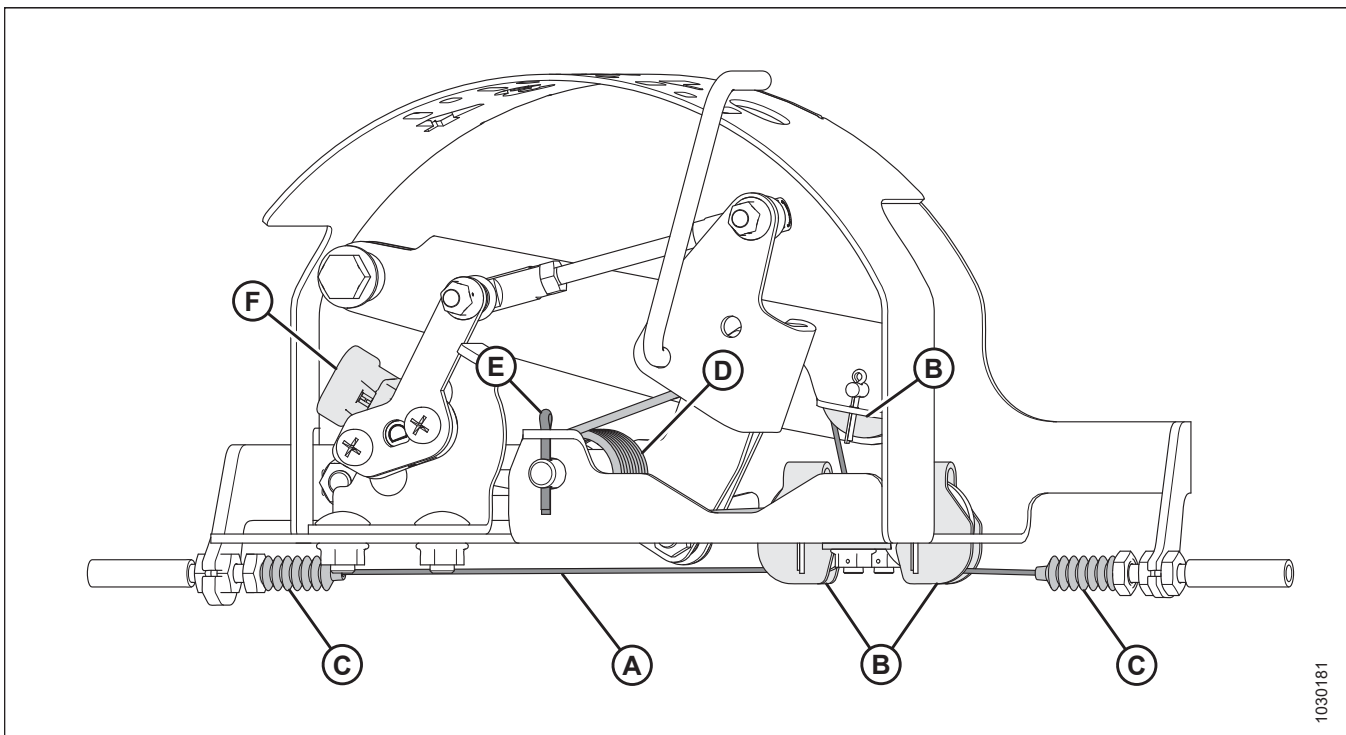

Figure 7.2: Float Indicator

## SETTING UP AUTO HEADER HEIGHT CONTROL

**Table 7.1 Auto Header Height / Float Indicator Troubleshooting**

Problem	Solution	Refer to
<b>Symptom: Float indicator not moving</b>		
Cable (A) is frayed	Replace cable.	
Excessive material built up inside float indicator / auto header height frame	Clean out material.	—
Cable (A) fell off of pulleys (B)	Check pulleys and replace them if necessary.	—
Rubber sheath (C) came off of cable (A) and gets caught on the pulley	Install cable ties around the rubber sheath and cable to secure it.	—
Spring (D) seized from corrosion	Replace spring.	—
Cotter pin (E) breaks and pin spins	Check for seized pin in bore, clean if necessary, and then replace cotter pin.	—
Voltage range too low or high	Adjust voltage range.	<a href="#">7.1.3 Sensor Output Voltage Range – Combine Requirements, page 187</a>
Faulty sensor (F)	Replace sensor.	See your MacDon Dealer

### 7.1.3 Sensor Output Voltage Range – Combine Requirements

The auto header height control (AHHC) sensor output must be within a specific voltage range for each combine, or the AHHC feature will not work properly.

**Table 7.2 Combine Voltage Limits**

Combine	Low Voltage Limit	High Voltage Limit	Range (Difference between High and Low Limits)
AGCO IDEAL™ Series	0.5 V	4.5 V	2.5 V
Case IH 5088/6088/7088, 5130/6130/7130, 7010/8010, 7120/8120/9120, 7230/8230/9230, and 7240/8240/9240	0.5 V	4.5 V	2.5 V
Case IH 2588/2577	2.8 V	7.2 V	4.0 V
Challenger, Gleaner A, and Massey Ferguson	0.5 V	4.5 V	2.5 V
CLAAS 500/600/700 Series, 7000/8000 Series, and Tucano Series	0.5 V	4.5 V	2.5 V
Gleaner R and S Series	0.5 V	4.5 V	2.5 V
John Deere 60, 70, S, and T Series	0.5 V	4.5 V	2.5 V
New Holland CR/CX - 5 V system	0.7 V	4.3 V	2.5 V
New Holland CR/CX - 10 V system	2.8 V	7.2 V	4.1–4.4 V
<b>NOTE:</b> Some combine models do not support checking sensor output voltage from the cab (early Case 23/2588 series, CLAAS 500/600/700 Series). For these models, check output voltage manually. For instructions, refer to <a href="#">Manually Checking Voltage Range – One-Sensor System, page 188</a> or <a href="#">Manually Checking Voltage Range – Two-Sensor System, page 191</a> .			

## SETTING UP AUTO HEADER HEIGHT CONTROL

### 10 Volt Adapter (MD #B6421) – New Holland Combines Only

New Holland combines with a 10 V system require the 10 V adapter (A) (MD #B6421) for proper calibration of the auto header height control (AHC) feature.

If a 10 V New Holland combine does not have the adapter installed, the AHC output will always read 0 V, regardless of sensor position.

**NOTE:**

A 10 V adapter is not available for the optional two-sensor system.

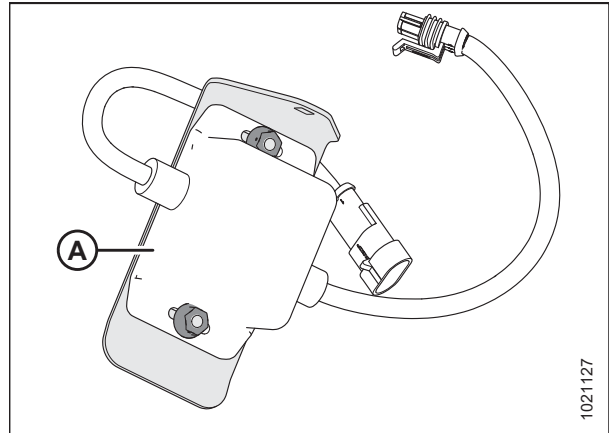

Figure 7.3: 10 V Adapter (MD #B6421)

Use a voltmeter to measure the voltage between Pin 1 (power) and Pin 2 (ground) wires at the AHC sensor (A). This will determine whether the combine has a 5 V system or a 10 V system.

**NOTE:**

The combine key must be in the ON position, but the engine does not need to be running.

The three possible voltage readings are as follows:

- 0 V – combine key is in OFF position, or there is a faulty harness/bad connection
- 5 V – standard combine reading
- 10 V – 10 V combine reading; adapter (MD #B6421) is required

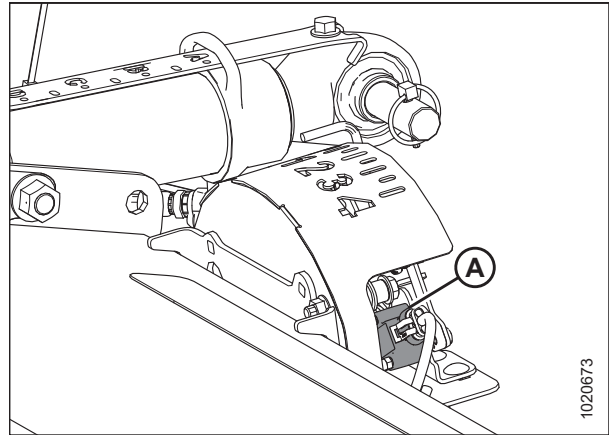

Figure 7.4: Float Indicator Box

### Manually Checking Voltage Range – One-Sensor System

The one-sensor system is standard for the FM100 Float Module. If equipped with the optional two-sensor system, refer to [Manually Checking Voltage Range – Two-Sensor System, page 191](#).

The output voltage range of the auto header height control (AHC) sensors in some combines can be checked from the cab. For instructions, refer to your combine operator's manual or the AHC instructions later in this document.

To manually check the sensor's output voltage range, follow these steps:

1. Extend guard angle fully; the header angle indicator should be at **D**.
2. Position the header 150 mm (6 in.) above the ground, and unlock the float.



## SETTING UP AUTO HEADER HEIGHT CONTROL

3. Check that float lock linkage is on down stops (washer [A] cannot be moved) at both locations.

**NOTE:**

If the header is **NOT** on down stops during the next two steps, the voltage may go out of range during operation causing a malfunction of the AHHC system.

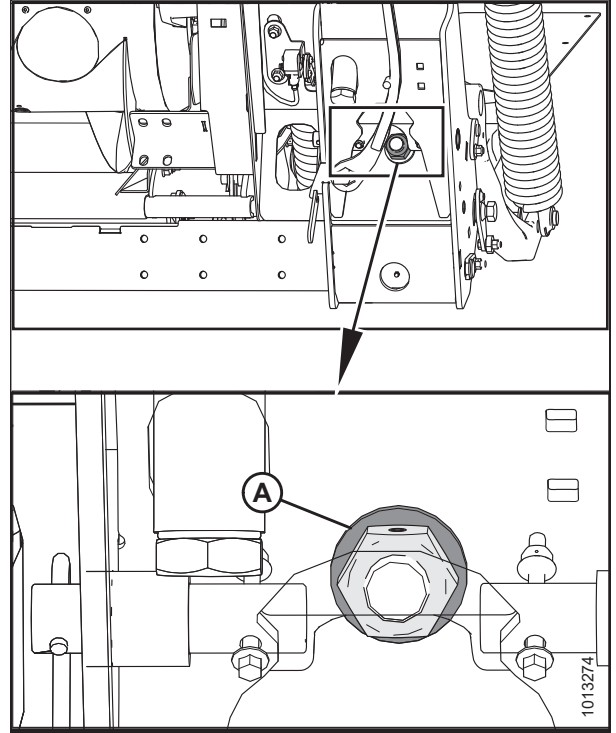

Figure 7.5: Down Stop Washer

4. Locate linkage assembly (A). Verify that dimension (B) is set to 55 mm (2 3/16 in.). If it is not, adjust linkage (A).

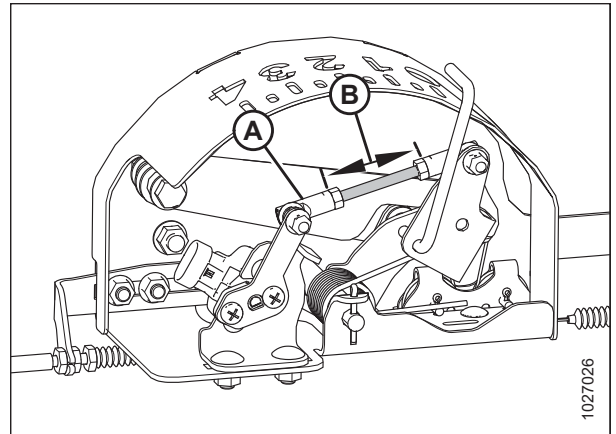

Figure 7.6: Float Indicator Box

## SETTING UP AUTO HEADER HEIGHT CONTROL

- Adjust cable take-up bracket (B) (if necessary) until float indicator pointer (A) is on 0.

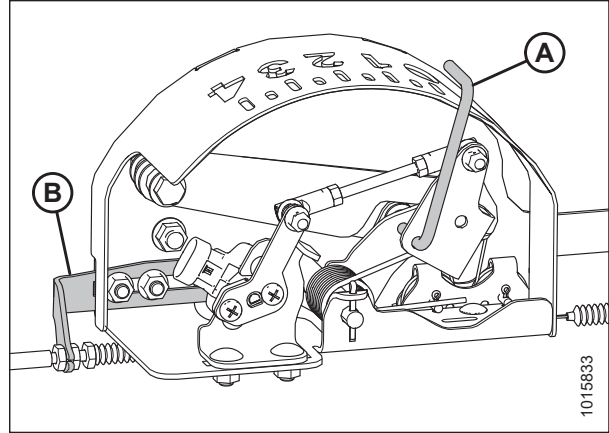

Figure 7.7: Float Indicator Box

- Use a voltmeter (A) to measure the voltage between the ground (Pin 2) and signal (Pin 3) wires at the AHHC sensor in the float indicator box. Ensure it is at the high voltage limit for the combine. For voltage limit chart, refer to Table 7.2, page 187.

**NOTE:**

The wiring harness connector must be attached to the sensor. Do **NOT** disconnect it.

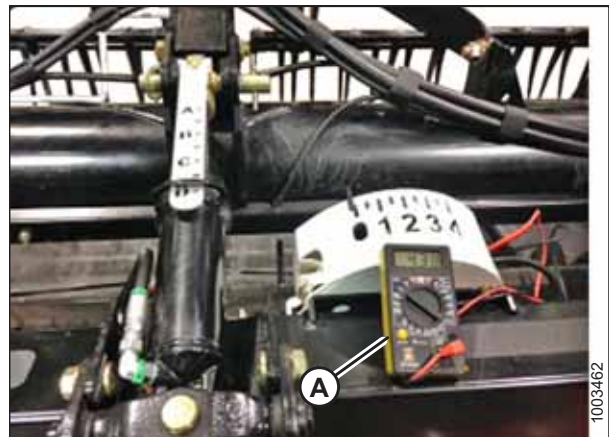

Figure 7.8: Measuring Voltage at Float Indicator Box

- Fully lower the combine feeder house, and float the header up off the down stops (float indicator should be at 4, and the float module should be fully separated from the header).

**NOTE:**

You may need to hold the HEADER DOWN switch for a few seconds to ensure the feeder house is fully lowered.

- Use a voltmeter (A) to measure the voltage between the ground and signal wires at the AHHC sensor in the float indicator box. It should be at the low voltage limit for the combine. For voltage limit chart, refer to Table 7.2, page 187.

**NOTE:**

The wiring harness connector must be attached to the sensor. Do **NOT** disconnect it.

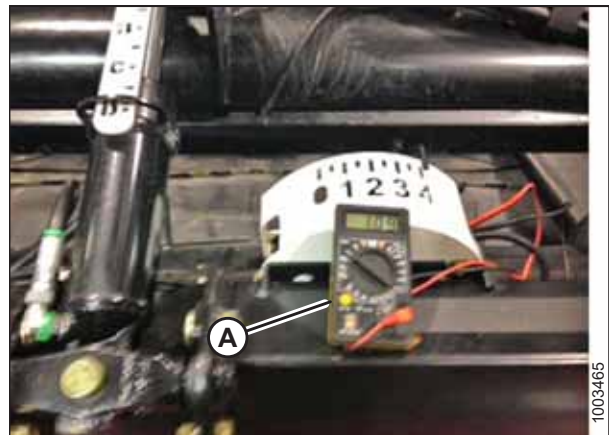

Figure 7.9: Measuring Voltage at Float Indicator Box

- If the sensor voltage is not within the low and high limits, or if the range between the low and high limits is insufficient, adjust the voltage limits. Refer to *Adjusting Voltage Limits – One-Sensor System*, page 194.

## SETTING UP AUTO HEADER HEIGHT CONTROL

### Manually Checking Voltage Range – Two-Sensor System

FM100 Float Modules equipped with the optional two-sensor system have a left and right sensor located on the back frame of the float module.

#### **WARNING**

To avoid injury or death from unexpected start-up of machine, always stop the engine and remove the key from the ignition before leaving the operator's seat for any reason.

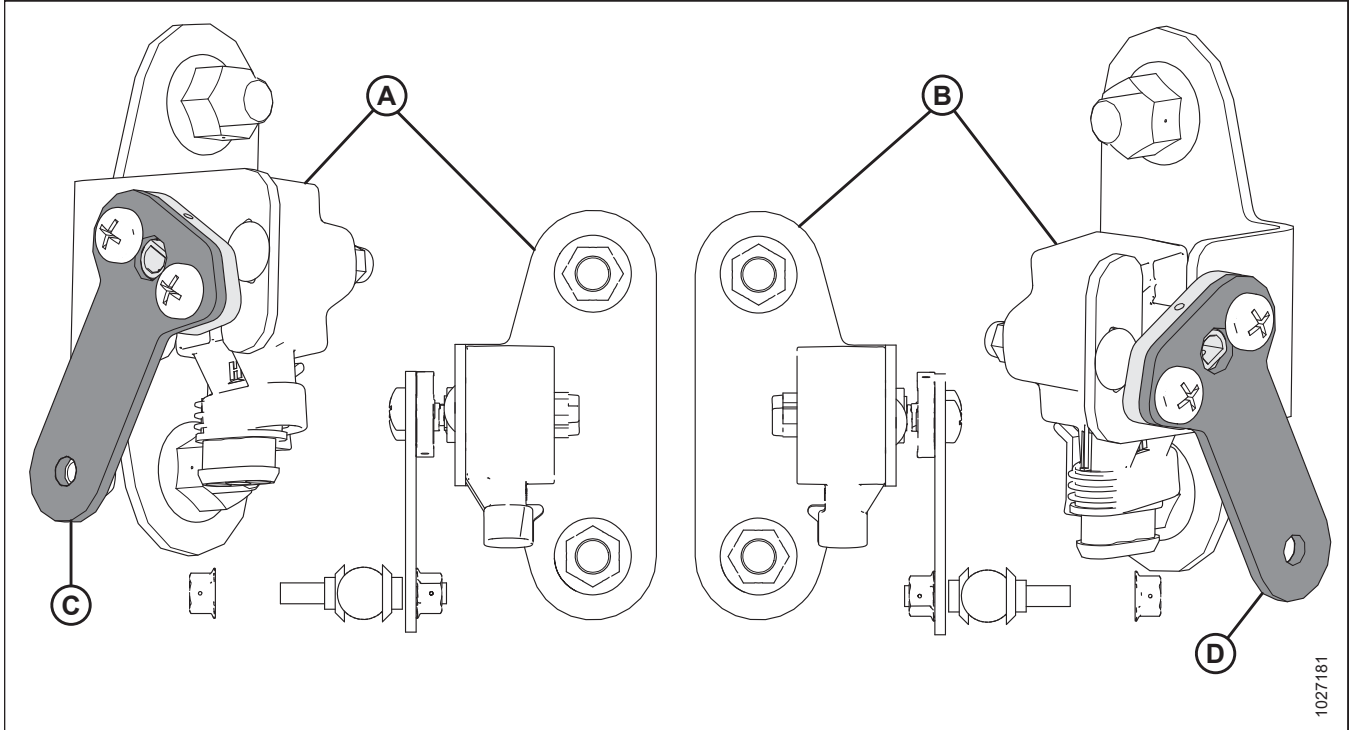

**Figure 7.10: Sensor Orientation**

1. Before adjusting the sensors, verify the sensor arms are properly installed on the sensors.
  - Left Sensor (A): The **point** on the arm of the sensor should face **away** from the header. The point on the float sensor arm (C) should be installed in the same direction, facing away from the header.
  - Right Sensor (B): The **point** on the arm of the sensor should face **away** from the header. The point on the float sensor arm (D) should be installed in the same direction, facing away from the header.

**To manually check the sensor's output voltage range, follow these steps:**

2. Extend guard angle fully; the header angle indicator should be at **D**.
3. Position the header 150 mm (6 in.) above the ground, and unlock the float.

## SETTING UP AUTO HEADER HEIGHT CONTROL

4. Check that float lock linkage is on down stops (washer [A] cannot be moved) at both locations.

**NOTE:**

If the header is not on down stops during the next two steps, the voltage may go out of range during operation causing a malfunction of the AHHC system.

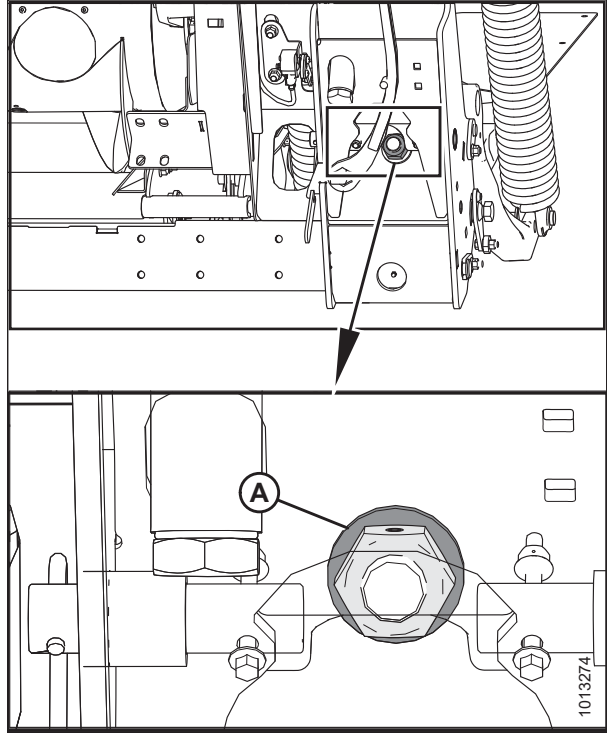

Figure 7.11: Down Stop Washer

5. Locate linkage assembly (A). Verify that dimension (B) is set to 55 mm (2 3/16 in.). If it is not, adjust linkage (A).

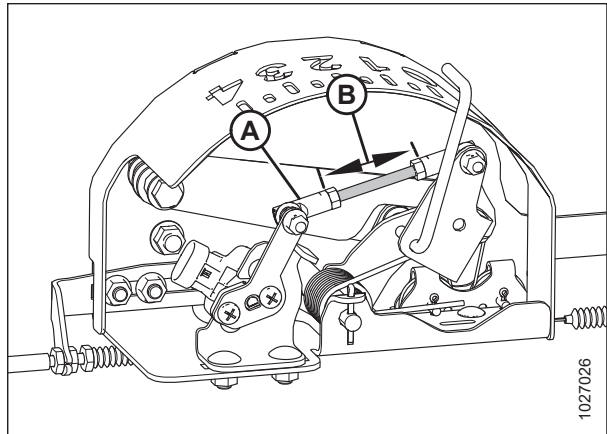

Figure 7.12: Float Indicator Box

## SETTING UP AUTO HEADER HEIGHT CONTROL

- Adjust cable take-up bracket (B) (if necessary) until pointer (A) on the float indicator is on **0**.

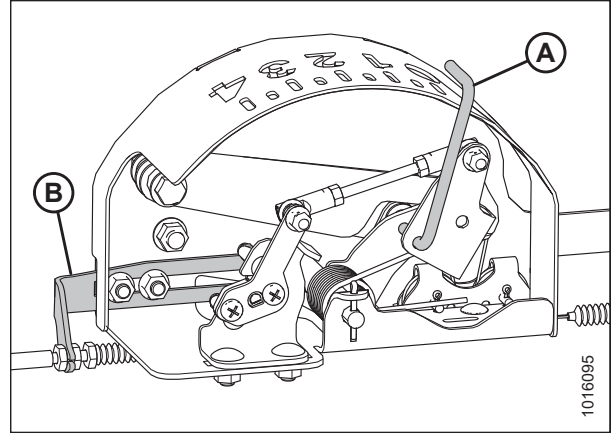

Figure 7.13: Float Indicator Box

- Use a voltmeter to measure the voltage between the ground (Pin 2) and signal (Pin 3) wires of AHHC sensor (A) at the back of the float module side frame. Ensure it is at the high voltage limit for the combine. For voltage limit chart, refer to Table 7.2, page 187.

**NOTE:**

The wiring harness connector must be attached to the sensor. Do **NOT** disconnect it.

- Repeat at the opposite side.

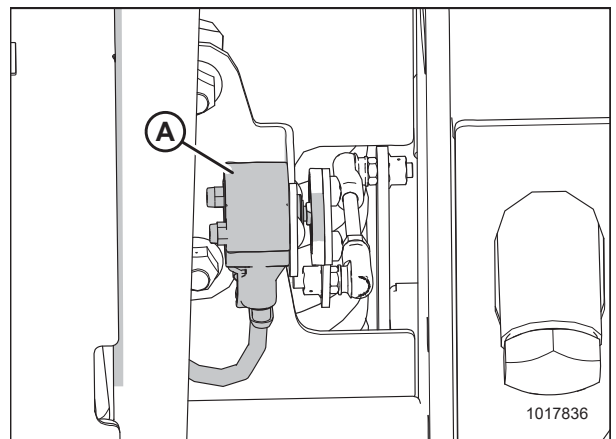

Figure 7.14: Optional Two-Sensor Kit – Right Sensor

- Fully lower the combine feeder house, and float the header up off the down stops (float indicator [A] should be at **4**, and the float module should be fully separated from the header).

**NOTE:**

You may need to hold the HEADER DOWN switch for a few seconds to ensure the feeder house is fully lowered.

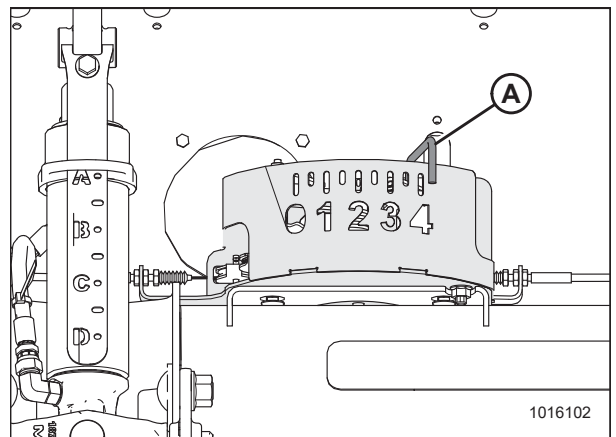

Figure 7.15: Float Indicator Box

## SETTING UP AUTO HEADER HEIGHT CONTROL

- Using a voltmeter, measure the voltage between the ground (Pin 2) and signal (Pin 3) wires of AHHC sensor (A) at the back of the side frame. Ensure it is at the low voltage limit for the combine. For voltage limit chart, refer to Table 7.2, page 187.

### NOTE:

The wiring harness connector must be attached to the sensor. Do **NOT** disconnect it.

- If the sensor voltage is not within the low and high limits, or if the range between the low and high limits is insufficient, adjust the voltage limits. For instructions, refer to *Adjusting Voltage Limits – Two-Sensor System*, page 195.
- Repeat at the opposite side.

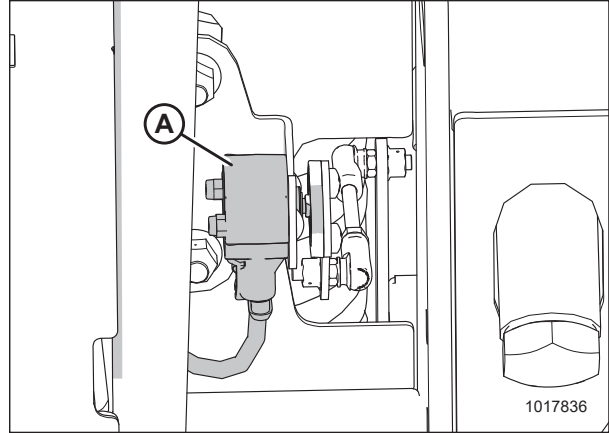

Figure 7.16: Optional Two-Sensor Kit – Right Sensor

### Adjusting Voltage Limits – One-Sensor System

Follow this procedure if you have checked the voltage range (either manually or from the cab) and found that the sensor voltage is not within the low and high limits, or that the range between the low and high limits is insufficient.

### WARNING

To avoid injury or death from unexpected start-up of machine, always stop the engine and remove the key from the ignition before leaving the operator's seat for any reason.

- Follow these steps to adjust the high voltage limit:
  - Extend guard angle fully; the header angle indicator should be at **D**.
  - Position header 152–254 mm (6–10 in.) above the ground; the float indicator should be at **0**.
  - Check the high voltage limit using the combine display or a voltmeter. For voltage limit chart, refer to Table 7.2, page 187.
  - Loosen sensor-mounting nuts (A).
  - Slide sensor support (B) to the right to increase high voltage limit or to the left to decrease it.
  - Tighten sensor-mounting nuts (A).

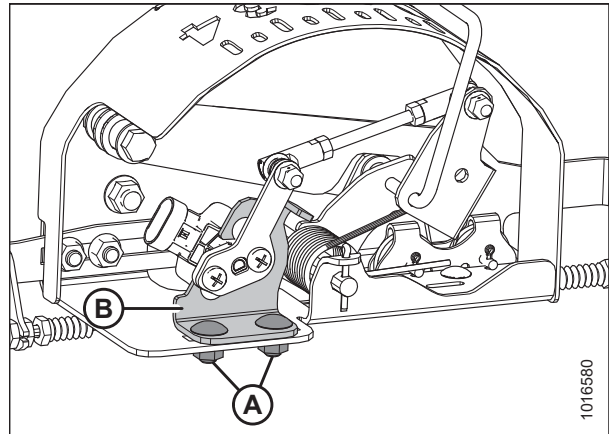

Figure 7.17: AHHC Sensor Assembly

## SETTING UP AUTO HEADER HEIGHT CONTROL

2. Follow these steps to adjust the low voltage limit:
  - a. Extend guard angle fully; the header angle indicator should be at **D**.
  - b. Fully lower header on the ground; the float indicator should be at **4**.
  - c. Check the low voltage limit using the combine display or voltmeter. For voltage limit chart, refer to Table 7.2, page 187.
  - d. Loosen sensor-mounting nuts (A).
  - e. Rotate sensor (B) clockwise to increase low voltage limit or counterclockwise to decrease it.
  - f. Tighten sensor-mounting nuts (A).
3. After making adjustments, recheck both the upper and lower voltage limits to make sure they are within the required range according to Table 7.2, page 187.

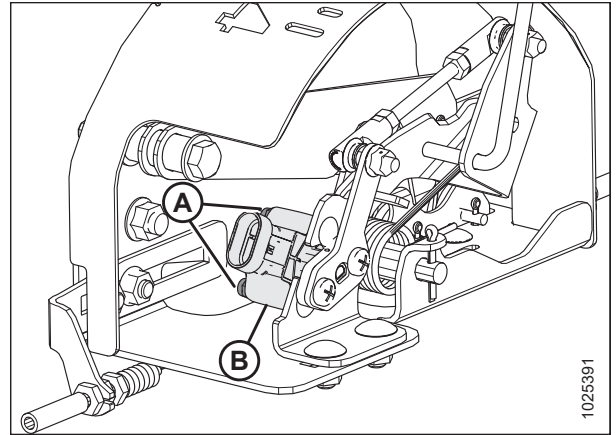

Figure 7.18: AHHC Sensor Assembly

### Adjusting Voltage Limits – Two-Sensor System

#### **WARNING**

To avoid injury or death from unexpected start-up of machine, always stop the engine and remove the key from the ignition before leaving the operator's seat for any reason.

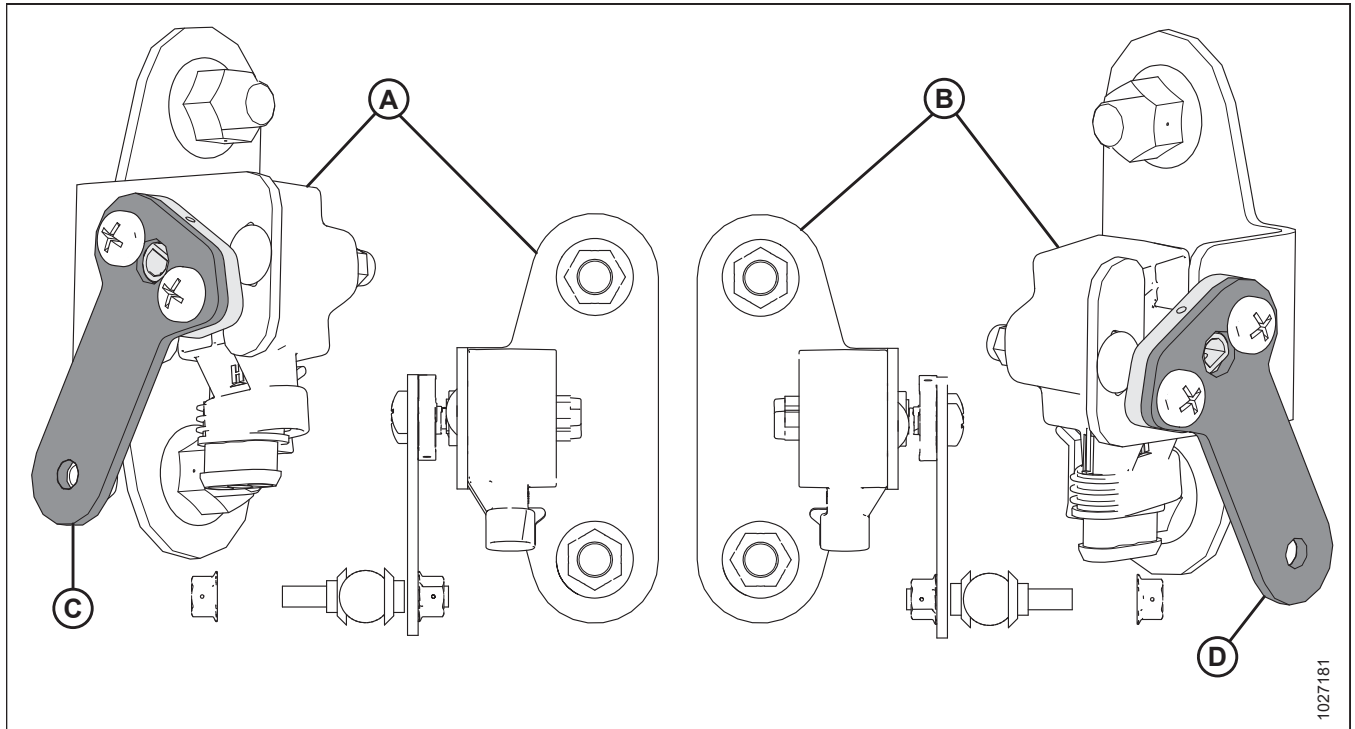

Figure 7.19: Sensor Orientation

1. Before adjusting the sensors, verify the sensor arms are properly installed on the sensors.
  - Left Sensor (A): The **point** on the arm of the sensor should face **away** from the header. The point on the float sensor arm (C) should be installed in the same direction, facing away from the header.

## SETTING UP AUTO HEADER HEIGHT CONTROL

- Right Sensor (B): The **point** on the arm of the sensor should face **away** from the header. The point on the float sensor arm (D) should be installed in the same direction, facing away from the header.

### *Follow these steps to adjust the left sensor voltage:*

2. Extend guard angle fully; the header angle indicator should be at **D**.
3. Position header 150–254 mm (6–10 in.) above the ground; the float indicator should be at **0**.
4. Loosen sensor-mounting nuts (A).
5. Check that the left sensor is at the correct high voltage limit.
6. Rotate sensor (B) counterclockwise to lower the voltage. Rotate sensor clockwise to raise the voltage.
7. Tighten sensor-mounting nuts (A).

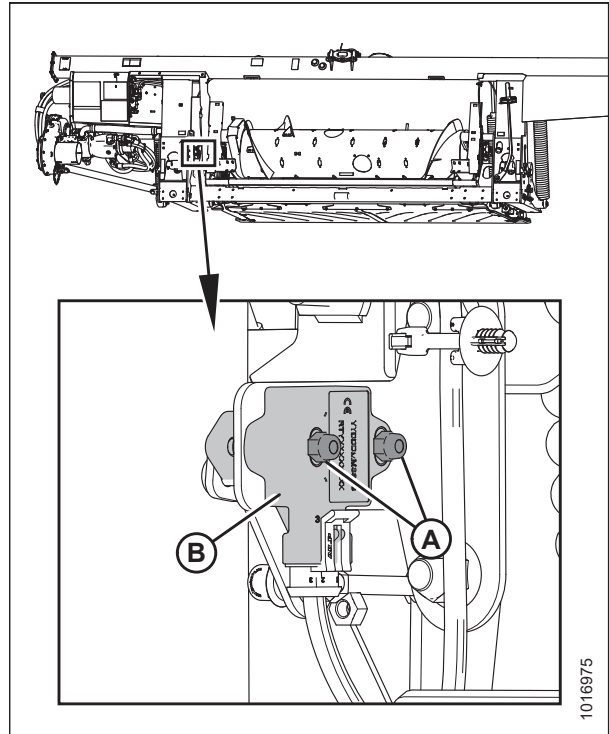

Figure 7.20: Optional Two-Sensor Kit – Left Sensor

### *Follow these steps to adjust the right sensor voltage:*

8. Extend guard angle fully; the header angle indicator should be at **D**.
9. Position header 150–254 mm (6–10 in.) above the ground; the float indicator should be at **0**.



## SETTING UP AUTO HEADER HEIGHT CONTROL

10. Loosen sensor mounting nuts (A).
11. Rotate sensor (B) clockwise to lower the voltage. Rotate sensor counterclockwise to raise the voltage.
12. Check that the right sensor is at the correct high voltage limit.
13. Tighten sensor mounting nuts (A).

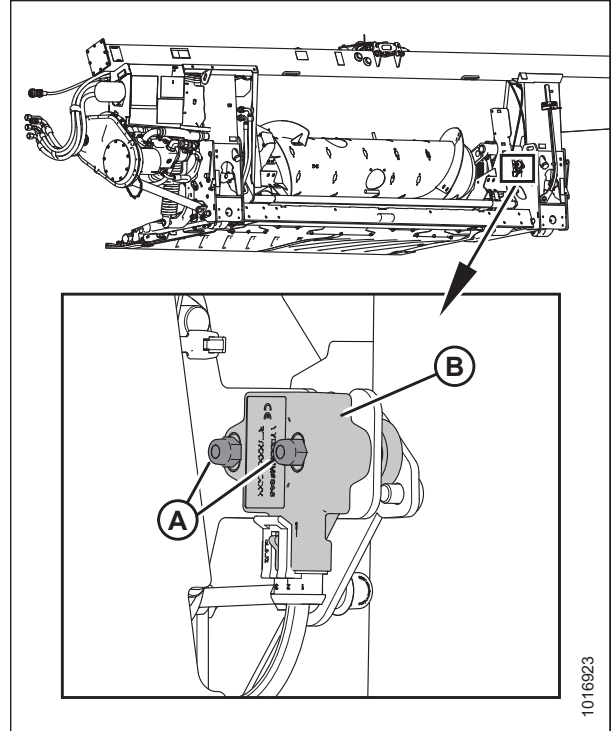

Figure 7.21: Optional Two-Sensor Kit – Right Sensor

14. Fully lower the header; float indicator (A) should be at 4.
15. Check that both sensors are at the correct low voltage limit.

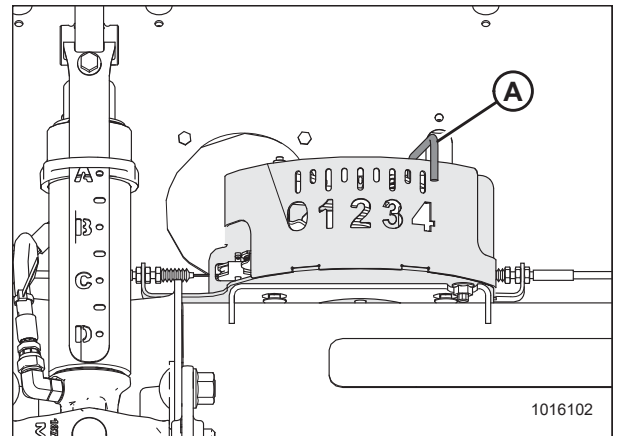

Figure 7.22: Float Indicator Box

### 7.1.4 AGCO IDEAL™ Series Combines

#### *Setting up the Header – AGCO IDEAL™ Series*

**NOTE:**

Up-to-date illustrations of the AGCO IDEAL™ Series combine display were not available at time of publishing. For instructions, refer to the combine operator's manual for updates.

## SETTING UP AUTO HEADER HEIGHT CONTROL

AGCO Tyton terminal (A) is used to set up and manage a MacDon header on an IDEAL™ combine. Use the touch screen display to select the desired item on the screen.



Figure 7.23: AGCO IDEAL™ Operator Station

A - Tyton Terminal    B - Control Handle  
C - Throttle        D - Header Control Cluster

1. On the top right of the home screen, touch COMBINE icon (A). The COMBINE MAIN MENU opens.

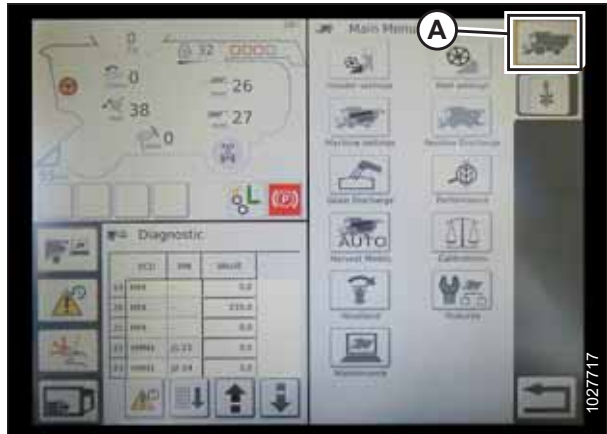

Figure 7.24: Combine Icon on Home Page

2. On the COMBINE MAIN MENU, touch HEADER SETTINGS (A). The HEADER SETTINGS page opens.

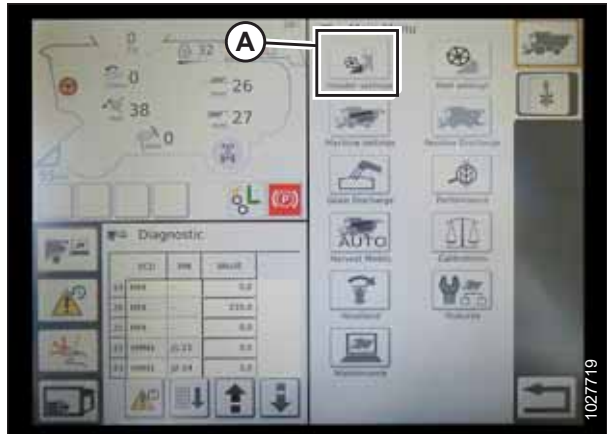
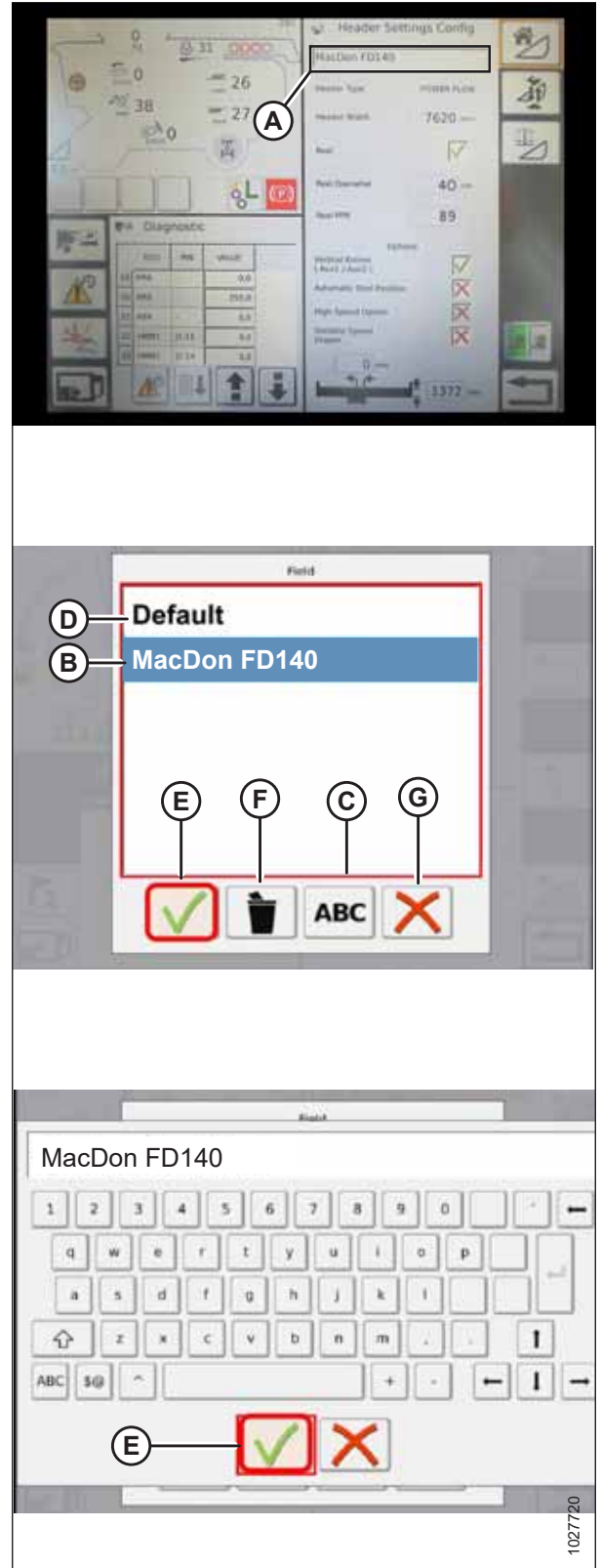

Figure 7.25: Header Settings in Combine Main Menu

## SETTING UP AUTO HEADER HEIGHT CONTROL

3. Touch **HEADER CONFIGURATION** field (A). A dialog box showing predefined headers opens.
  - If your MacDon header is already set up, it appears on the header list. Touch the MacDon header title (B) to highlight the selection in blue, and then touch green check mark (E) to continue.
  - If only default header (D) is shown, touch ABC button (C), and use the on-screen keyboard to enter the MacDon header information. When complete, select one of the following options to return to the **HEADER SETTINGS** page:
    - Green check mark (E) saves the settings
    - Garbage can icon (F) deletes the highlighted header from the list
    - Red X (G) cancels the change(s)



## SETTING UP AUTO HEADER HEIGHT CONTROL

- To specify the type of header installed on the machine, touch HEADER TYPE field (A).

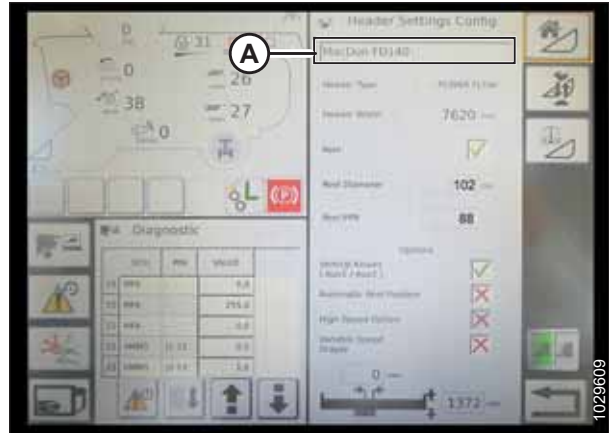

Figure 7.27: Header Settings

- A list of predefined header types appears.
  - For MacDon D1 Series Draper and FD1 Series FlexDraper® headers, touch POWER FLOW (A).
  - Touch green check mark (B) to save the selection and continue.

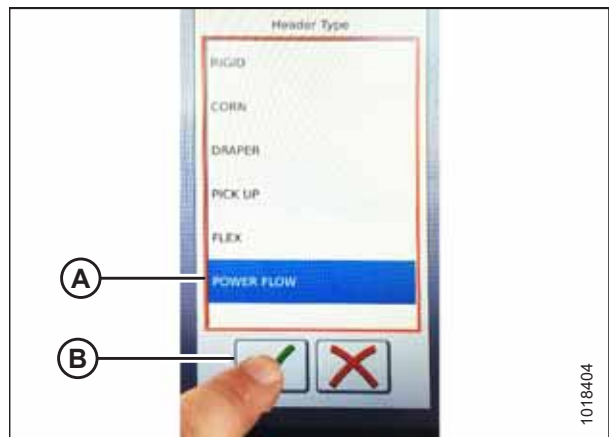

Figure 7.28: Header Type

- Make sure that REEL check box (A) is checked.

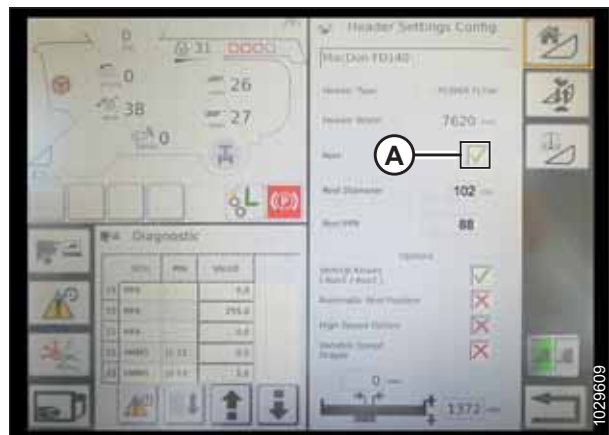

Figure 7.29: Header Settings

## SETTING UP AUTO HEADER HEIGHT CONTROL

- Touch REEL DIAMETER field (A) and a numeric keypad displays. Enter **13** for a MacDon reel.
- Touch REEL PPR (Pulses Per Revolution) field (B) and enter **18** as the value for your MacDon header.

**NOTE:**

PPR is determined by the number of teeth on the reel speed sprocket.

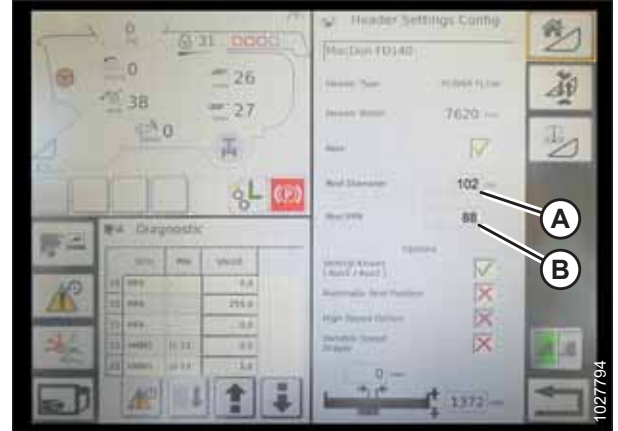

Figure 7.30: Header Settings

- Touch green check mark (B) at the bottom of numeric keypad (A) when complete, or the red X to cancel.

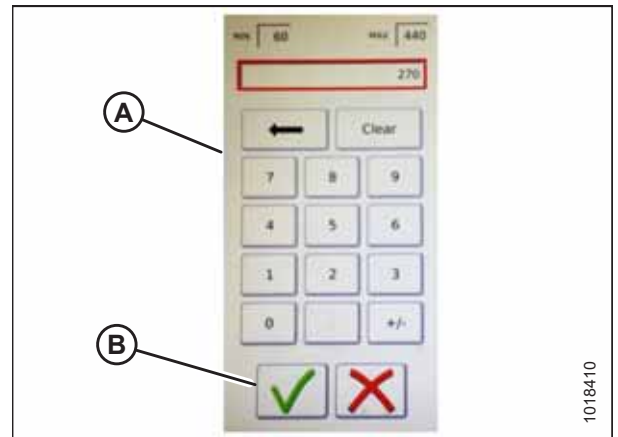

Figure 7.31: Numeric Keypad

- When complete, touch green check mark (A) at the bottom of the HEADER SETTINGS page.

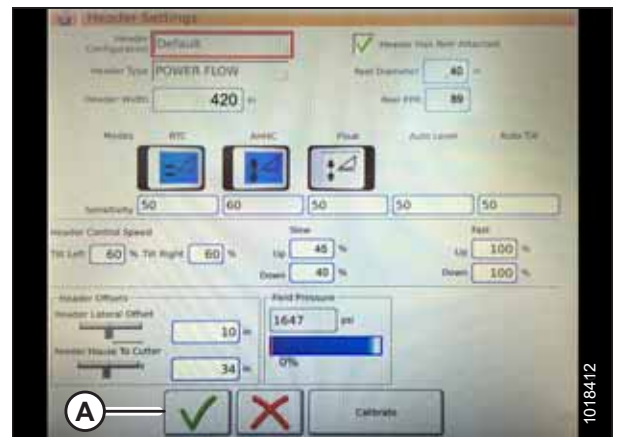

Figure 7.32: Header Settings Page

### Setting Minimum Reel Speed and Calibrating Reel – AGCO IDEAL™ Series

#### **WARNING**

Clear the area of other persons, pets etc. Keep children away from machinery. Walk around the machine to be sure no one is under, on, or close to it.

## SETTING UP AUTO HEADER HEIGHT CONTROL

### NOTE:

Up-to-date illustrations of the IDEAL™ combine display were not available at time of publishing. For instructions, refer to the combine operator's manual for updates.

1. From the COMBINE MAIN MENU, touch REEL SETTINGS (A) to open the REEL SETTINGS page.

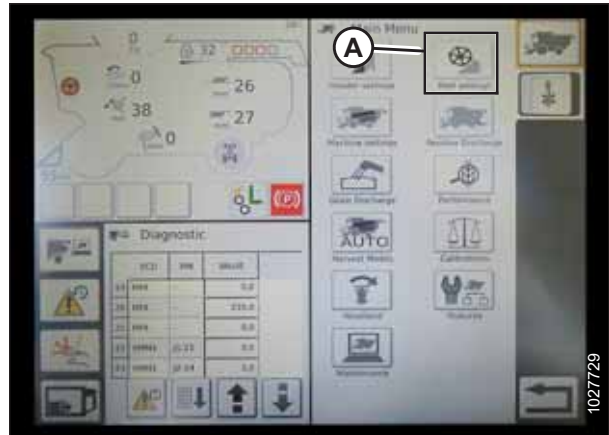

Figure 7.33: Reel Settings on Combine Main Menu

2. To set minimum reel speed, touch SPEED MINIMUM FIELD (B). The on-screen keyboard displays. Enter the desired value. Touch the green check mark to accept the new value, or the red X to cancel. The reel speed is shown in miles per hour (mph) and rotations per minute (rpm).

### NOTE:

At the bottom of the REEL SETTINGS page, the reel diameter and reel pulses per revolution (PPR) are displayed. These values have already been set in the HEADER SETTINGS page.

3. Reel speed is calibrated on the REEL SETTINGS page by touching CALIBRATE button (A) in the top right of the page.

### NOTE:

The CALIBRATION WIZARD opens and displays a hazard warning.

4. Make sure to meet all the conditions listed in the CALIBRATION WIZARD warning. Press the green check mark to accept and start reel calibration. Pressing the red X will cancel the calibration procedure.



Figure 7.34: Reel Settings Calibration



Figure 7.35: Calibration Wizard

## SETTING UP AUTO HEADER HEIGHT CONTROL

5. A message appears in the CALIBRATION WIZARD stating that reel calibration has started. The reel will begin turning slowly and increase to high speed. A progress bar is provided. If necessary, touch the red X (not shown) to cancel. Otherwise, wait for the message that reel calibration has completed successfully. Touch the green check mark to save the calibrated settings.



Figure 7.36: Calibration Progress

### Setting up Automatic Header Controls – AGCO IDEAL™ Series

Automatic header functions are configured on the HEADER SETTINGS page.

#### NOTE:

Up-to-date illustrations of the IDEAL™ Series combine display were not available at time of publishing. For instructions, refer to the combine operator's manual for updates.

1. **Automatic Control Functions:** There are toggle (OFF/ON) switches on the HEADER SETTINGS page for the automatic control functions. For MacDon headers, ensure the following two functions are enabled as shown:

- RTC (return to cut) (A)
- AHHC (automatic header height control) (B)

All other switches are disabled (not highlighted).

2. **Sensitivity** setting (C) controls how responsive a control (RTC or AHHC) is to a given change in sensor feedback. The setting fields are located directly below the toggle switches. To enter a new sensitivity setting, touch the setting field below the specific toggle switch, and enter the new value in the on-screen keyboard.

- Increase sensitivity if the combine does not change the feeder position quickly enough when in Auto Mode.
- Decrease sensitivity if the combine hunts for a position in Auto Mode.

#### NOTE:

Recommended sensitivity starting points for MacDon headers are:

- **50** for RTC (A)
- **60** for AHHC (B)

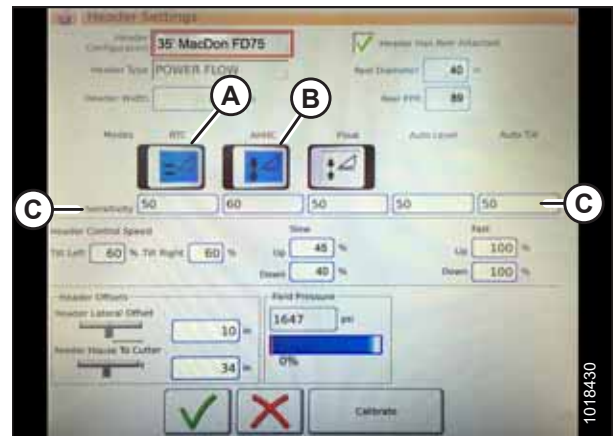

Figure 7.37: Automatic Controls and Sensitivity Settings

## SETTING UP AUTO HEADER HEIGHT CONTROL

3. **Header Speed:** HEADER CONTROL SPEED area (A) on the HEADER SETTINGS page is used to adjust the following speeds:

- Tilt left and right is the lateral tilt of the combine faceplate
- Header up and down (slow and fast speeds) is a two-stage button with slow speed on the first detent and fast on the second

**NOTE:**

Recommended header control speed starting points

- Slow: Up 45/Down 40
- Fast: Up 100/Down 100

4. **Header Offsets (A):** Offset distances are important for yield mapping. There are two adjustable dimensions on the HEADER SETTINGS page:

- Header Lateral Offset: the distance between the centerline of the header and the centerline of the machine. This should be set at **0** for a MacDon header.
- Feeder House to Cutter: the distance from the machine interface to the cutterbar. This should be set at **68** for a MacDon header.

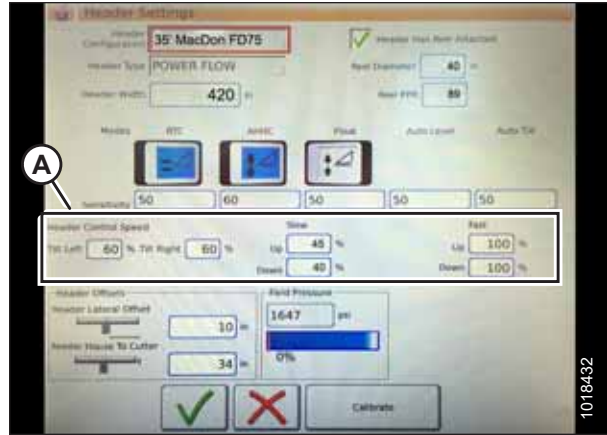

Figure 7.38: Header Speed Control Settings

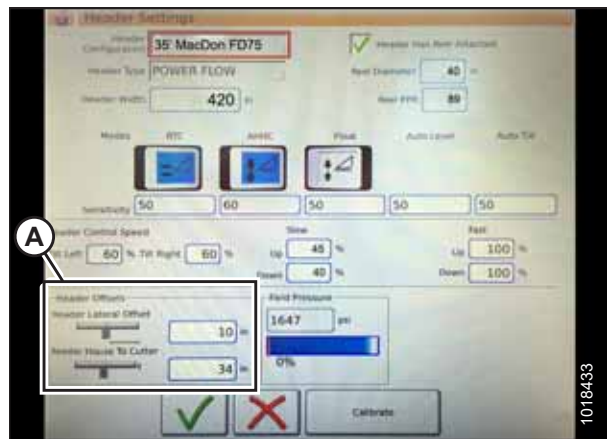

Figure 7.39: Header Offset Settings

### Calibrating the Header – AGCO IDEAL™ Series

The auto header control functions are configured on the HEADER SETTINGS page.

### WARNING

Clear the area of other persons, pets etc. Keep children away from machinery. Walk around the machine to be sure no one is under, on, or close to it.

**NOTE:**

Up-to-date illustrations of the IDEAL™ combine display were not available at time of publishing. For instructions, refer to the combine operator’s manual for updates.



## SETTING UP AUTO HEADER HEIGHT CONTROL

1. On the COMBINE MAIN MENU, touch HEADER SETTINGS (A).

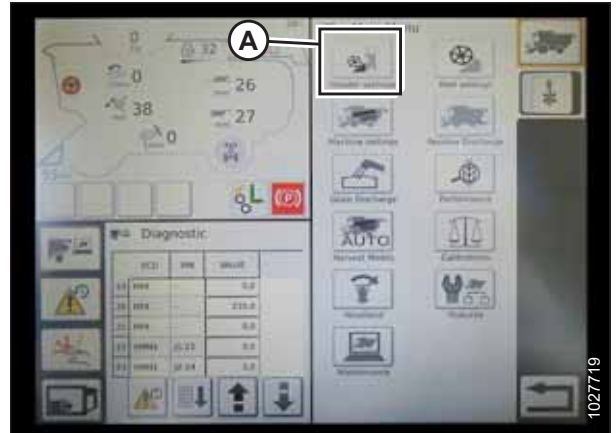

Figure 7.40: Combine Main Menu

2. Touch HEADER CALIBRATE (A) at the right side of the HEADER SETTINGS CONFIG page.

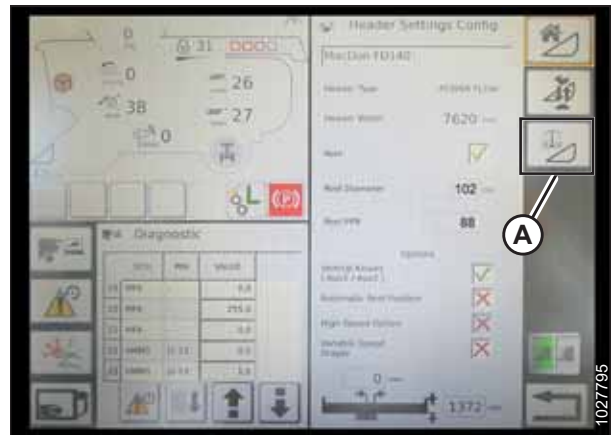

Figure 7.41: Header Settings Page

3. The hazard warning for HEADER CALIBRATION appears. Make sure that all conditions are met.
4. Touch the green check mark at the bottom of the page to start the calibration and follow the on-screen commands.



Figure 7.42: Header Calibration Warning

## SETTING UP AUTO HEADER HEIGHT CONTROL

A progress bar is provided and the calibration can be stopped by touching the red X. The header moves automatically and erratically during this process.

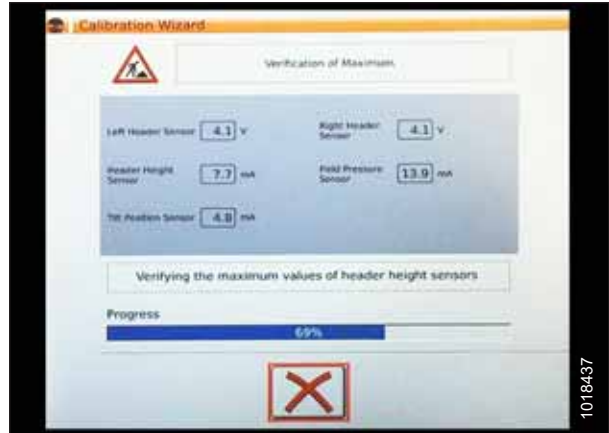

Figure 7.43: Calibration in Progress

5. When the calibration is complete:

- Review summary information (A)
- Review green check marks confirming calibrated functions (B)
- Touch check mark (C) to save



Figure 7.44: Completed Calibration Page

### NOTE:

Touch CALIBRATIONS icon (A) on MAIN MENU page to display the CALIBRATION MENU where you can choose from a variety of calibrations including header and reel calibration.

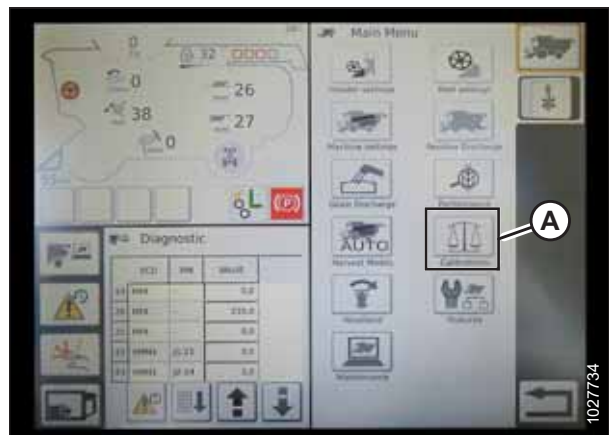

Figure 7.45: Direct Calibration Menu

## Operating the Header – AGCO IDEAL™ Series

### NOTE:

Up-to-date illustrations of the IDEAL™ combine display were not available at time of publishing. For instructions, refer to the combine operator's manual for updates.

## SETTING UP AUTO HEADER HEIGHT CONTROL

The following controls are used to operate the auto header height control (AHC) functions:

- Tyton terminal (A)
- Control handle (B)
- Throttle (C)
- Header control cluster (D)

For instructions, refer to the combine operator's manual to familiarize yourself with the controls.



Figure 7.46: AGCO IDEAL™ Operator Station

1. With the header running, set lateral tilt to MANUAL by pressing switch (A) so the light above switch is off.
2. Engage the AHC by pressing switch (B) so light above switch is on.



Figure 7.47: Header Control Cluster

3. Press AHC control switch (A) on the control handle to engage the AHC. The header moves to the current setpoint position.



Figure 7.48: AHC on Control Handle

## SETTING UP AUTO HEADER HEIGHT CONTROL

4. Use HEADER HEIGHT SETPOINT control dial (A) as necessary to fine-tune the position.



Figure 7.49: Header Control Cluster

### Reviewing Header In-Field Settings – AGCO IDEAL™ Series

#### NOTE:

Up-to-date illustrations of the IDEAL™ combine display were not available at time of publishing. For instructions, refer to the combine operator's manual for updates.

1. To view header group settings, touch HEADER icon (A) on the right side of the home page.
2. The following information is displayed:
  - CURRENT POSITION of header (B).
  - SETPOINT cut-off position (C) (indicated by red line)
  - HEADER symbol (D) – touch to adjust the setpoint cut-off position using the adjustment wheel on the right side of the Tyton terminal.
  - CUT HEIGHT for AHHC (E) – fine-tune with the header height setpoint control dial on the header control cluster.
  - HEADER WORKING WIDTH (F)
  - HEADER PITCH (G)
3. Touching a field opens the on-screen keyboard so that values can be adjusted. Enter the new value and touch the green check mark when complete.

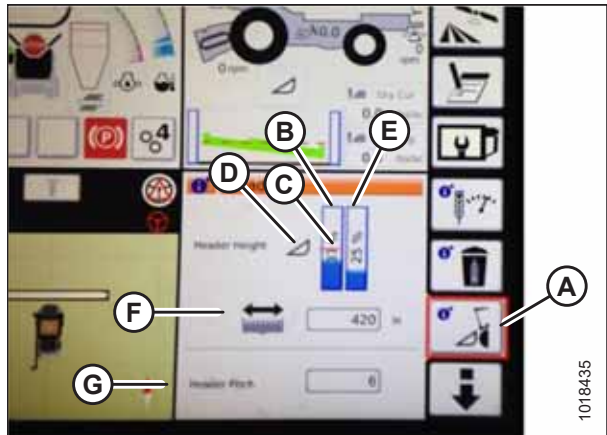

Figure 7.50: Header Groups



Figure 7.51: Adjustment Wheel on Right of Tyton Terminal

## SETTING UP AUTO HEADER HEIGHT CONTROL

**NOTE:**

HEADER HEIGHT SETPOINT control dial (A) is on the header control cluster.



Figure 7.52: Header Control Cluster

### 7.1.5 Case IH 5088/6088/7088 Combines

#### *Calibrating the Auto Header Height Control – Case IH 5088/6088/7088*

For best performance of the auto header height control (AHHC) system, perform ground calibration with center-link set to **D**. When calibration is complete, adjust the center-link back to desired header angle. For instructions, refer to the header operator's manual.

**NOTE:**

Changes may have been made to the combine controls or display since this document was published. For instructions, refer to the combine operator's manual for updates.



#### **WARNING**

**Check to be sure all bystanders have cleared the area.**

**NOTE:**

If header float is set too light, it can prevent calibration of AHHC. You may need to set the float heavier for calibration procedure so header doesn't separate from the float module.

1. Ensure center-link is set to **D**.
2. Set the float. For instructions, refer to operator's manual for instructions.
3. Position fore-aft in midspan.
4. Start the combine engine, but do **NOT** engage separator or feeder house.
5. Locate HEADER CONTROL switch (A) on the right console, and set to HT (this is AHHC mode).

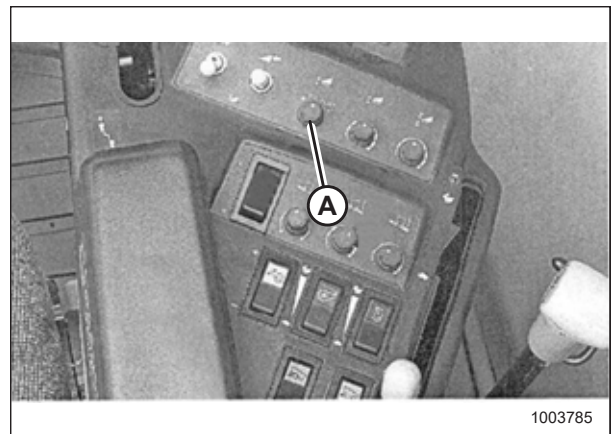

Figure 7.53: Right Console

## SETTING UP AUTO HEADER HEIGHT CONTROL

6. Press HEADER LOWER switch (A) on the control handle until the float module and header are fully lowered. You may need to hold the switch for several seconds.
7. Press HEADER RAISE switch (A) on the control handle. The header should stop at about the halfway point. Continue holding the HEADER RAISE switch, and the header will rise until the feeder house reaches its upper limit. The AHHC system is now calibrated.

**NOTE:**

If float was set heavier to complete the AHHC calibration procedure, adjust to recommended operating float after the calibration is complete.

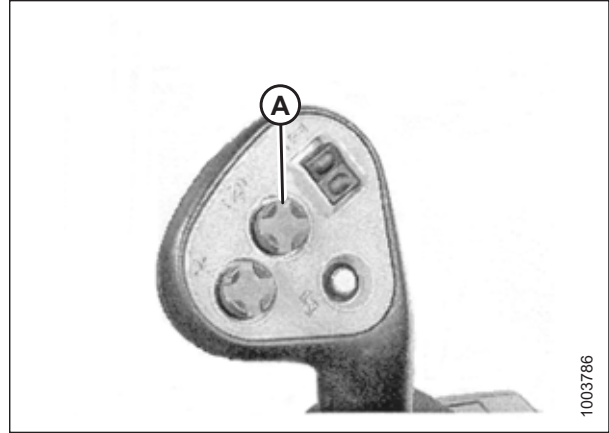

Figure 7.54: Control Handle – Case IH 2300/2500

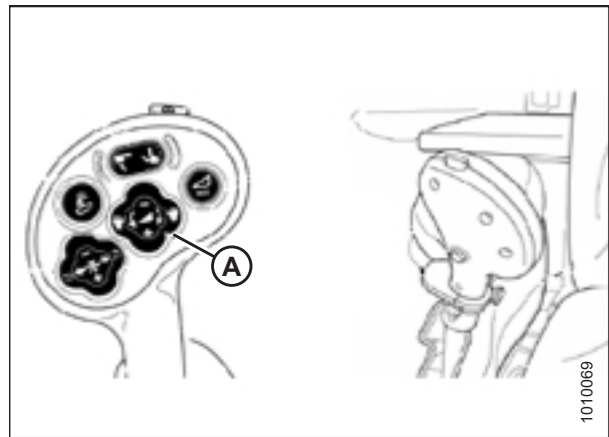

Figure 7.55: Control Handle – Case IH 5088/6088/7088

### *Setting the Sensitivity of the Auto Header Height – Case IH 5088/6088/7088*

The sensitivity adjustment controls the distance the cutterbar must travel up or down before the auto header height control (AHHC) reacts and raises or lowers the feeder house. When the sensitivity is set to maximum, only small changes in ground height are needed to cause the feeder house to raise or lower. When the sensitivity is set to minimum, large changes in the ground height are needed to cause the feeder house to raise or lower.

**NOTE:**

Changes may have been made to the combine controls or display since this document was published. Refer to the combine operator's manual for updates.

## SETTING UP AUTO HEADER HEIGHT CONTROL

1. Use HEADER SETTINGS key (A) to display the HEADER SENSITIVITY CHANGE page as shown in Figure 7.57, page 211.
2. Use the UP key (B) or DOWN key (C) to adjust the highlighted item. The height sensitivity setting range is 0 (least sensitive) to 250 (most sensitive) in increments of 10.

**NOTE:**

Adjustments take effect immediately. Use the CANCEL key to return to the original settings.

3. Use HEADER SETTINGS key (A) to highlight the next changeable item.
4. Use ENTER key (D) to save changes and return to the monitor screen. If there are no changes, the screen will return to the monitor screen after 5 seconds.



Figure 7.56: Combine Controls

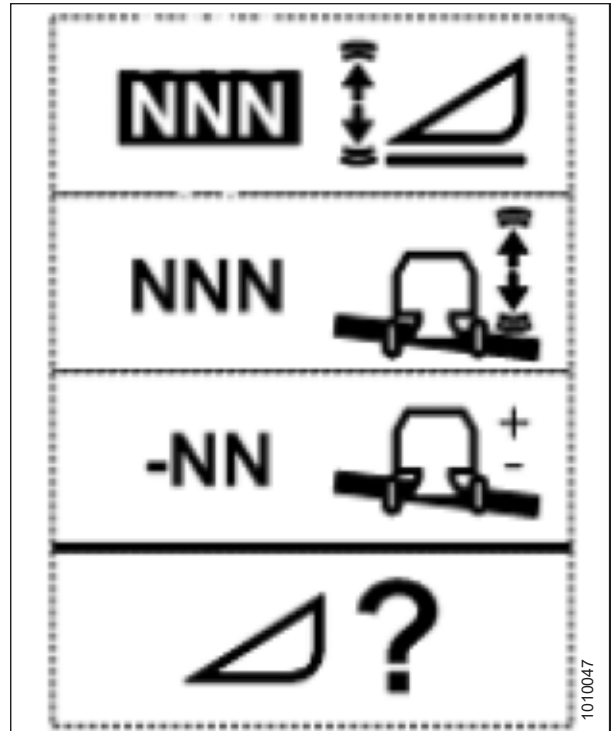

Figure 7.57: Height Sensitivity Change Page

## SETTING UP AUTO HEADER HEIGHT CONTROL

### 7.1.6 Case IH 130 and 140 Series Mid-Range Combines

#### Setting up the Header on the Combine Display – Case IH 5130/6130/7130; 5140/6140/7140

1. On the main page of the combine display, select TOOLBOX (A).

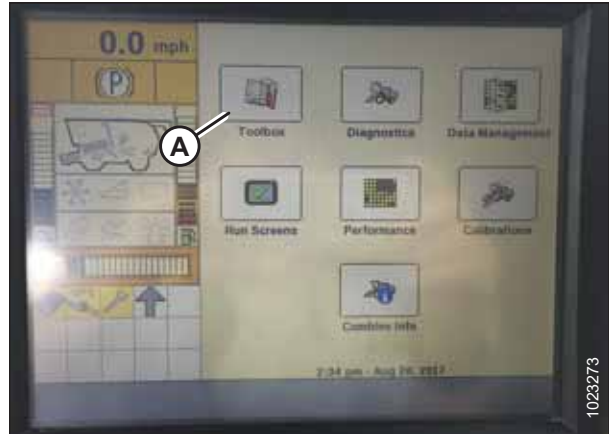

Figure 7.58: Case IH Combine Display

2. Select HEAD 1 tab (A). The HEADER SETUP page displays.

**NOTE:**

To locate the HEAD 1 tab, you may need to scroll to the right using side arrows (C).

3. From CUTTING TYPE menu (B), select PLATFORM.

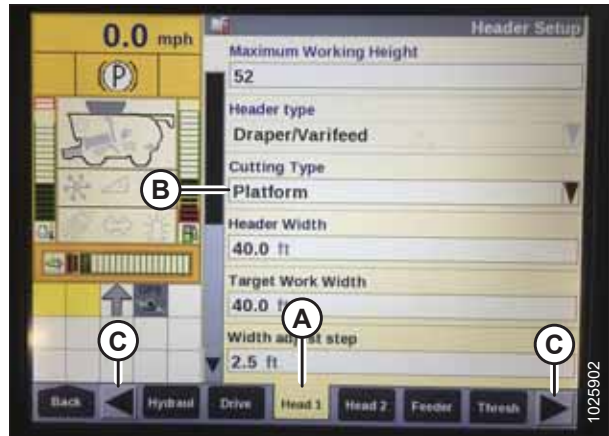

Figure 7.59: Case IH Combine Display

4. Select HEAD 2 tab (A). The HEADER SETUP 2 page displays.
5. From HEADER PRESSURE FLOAT menu (B), select NOT INSTALLED.
6. From DRAPER GRAIN HEADER STYLE menu (C), select FLEX 2000 SERIES.

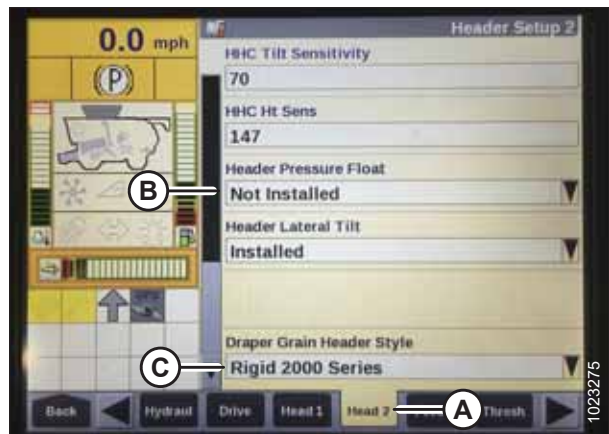

Figure 7.60: Case IH Combine Display



## SETTING UP AUTO HEADER HEIGHT CONTROL

- Locate HHC HEIGHT SENSITIVITY field (A), and set as follows:

- If using a two-sensor system:** Set HHC HEIGHT SENSITIVITY to 250.
- If using a single-sensor system:** Set HHC HEIGHT SENSITIVITY to 180.

**NOTE:**

If hunting occurs during operation, decrease this setting by 20 points at a time until hunting no longer occurs.

- Set HHC TILT SENSITIVITY (B) to 150. Increase or decrease as desired.



Figure 7.61: Case IH Combine Display

- From REEL DRIVE TYPE menu (A), select one of the following:

- 4 if you are using a standard 19-tooth drive sprocket.
- 5 if you are using an optional high-torque 14-tooth drive sprocket.
- 6 if you are using an optional high-torque 10-tooth drive sprocket.

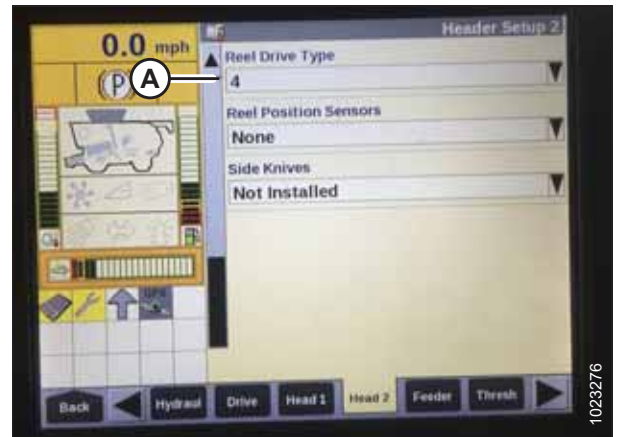

Figure 7.62: Case IH Combine Display

- From REEL HEIGHT SENSOR menu (A), select YES.



Figure 7.63: Case IH Combine Display

## SETTING UP AUTO HEADER HEIGHT CONTROL

11. Locate AUTOTILT field (A).

- **If using a two-sensor system:** Select YES in the AUTOTILT field.
- **If using a single-sensor system:** Select NO in the AUTOTILT field.



Figure 7.64: Case IH Combine Display

### Checking Voltage Range from Combine Cab – Case IH 5130/6130/7130; 5140/6140/7140

#### NOTE:

Changes may have been made to combine controls or display since this document was published. For instructions, refer to the combine operator's manual for updates.

#### WARNING

Check to be sure all bystanders have cleared the area.

1. Position the header 150 mm (6 in.) above the ground, and unlock the float.
2. Check that float lock linkage is on down stops (washer [A] cannot be moved) at both locations.

#### NOTE:

If the header is not on down stops during the next two steps, the voltage may go out of range during operation causing a malfunction of the auto header height control (AHHC) system.

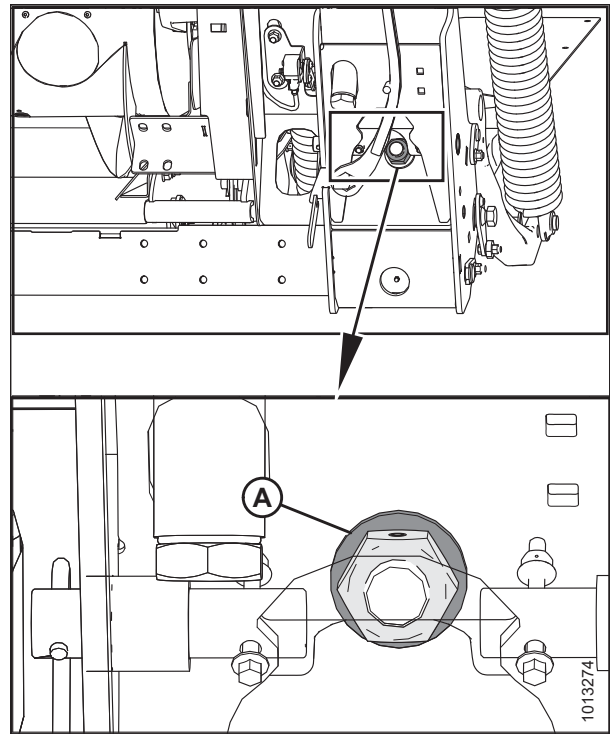

Figure 7.65: Float Lock

## SETTING UP AUTO HEADER HEIGHT CONTROL

3. Adjust cable take-up bracket (B) (if necessary) until pointer (A) on float indicator is on **0**.
4. Ensure header float is unlocked.

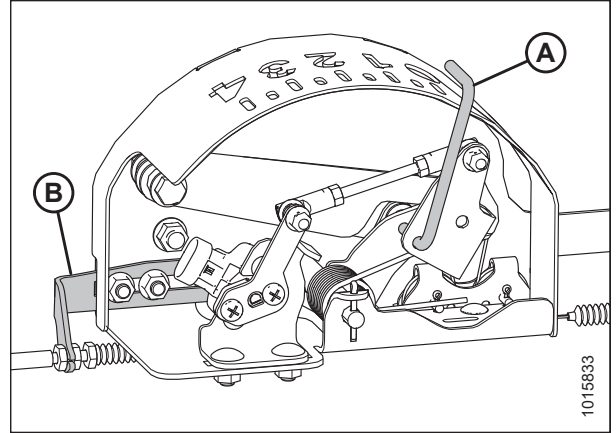

Figure 7.66: Float Indicator Box

5. On the main page of the combine display, select **DIAGNOSTICS (A)**. The **DIAGNOSTICS** page opens.

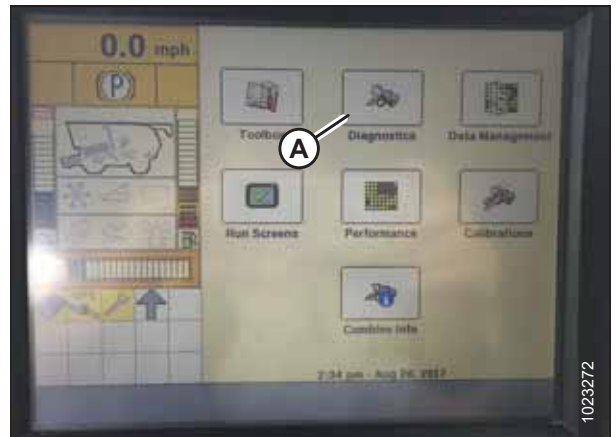

Figure 7.67: Case IH Combine Display

6. Select **SETTINGS (A)**. The **SETTINGS** page opens.
7. From the **GROUP** menu, select **HEADER (B)**.

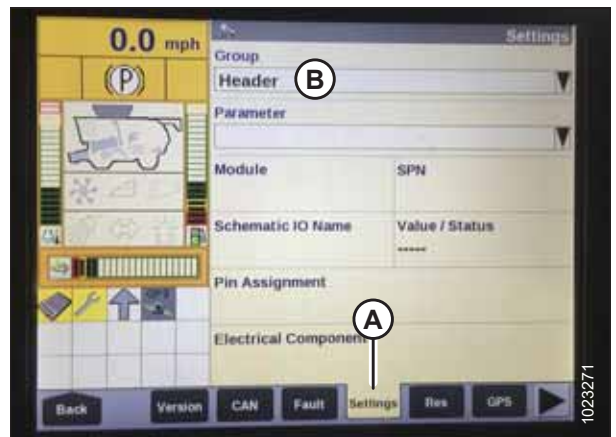

Figure 7.68: Case IH Combine Display

## SETTING UP AUTO HEADER HEIGHT CONTROL

- From the PARAMETER menu, select LEFT HEIGHT/TILT SENSOR (A).



Figure 7.69: Case IH Combine Display

- The SETTINGS page updates to display the voltage in VALUE/STATUS field (A). Lower the feeder house fully, and then raise it 254–306 mm (10–14 in.) off the ground to view the full range of voltage readings.
- If the sensor voltage is not within the low and high limits, or if the range between the low and high limits is insufficient, adjust the voltage limits. For instructions, refer to *Adjusting Voltage Limits – One-Sensor System*, page 194.



Figure 7.70: Case IH Combine Display

### Calibrating Auto Header Height Control – Case IH 5130/6130/7130, 5140/6140/7140

For best performance of the auto header height control (AHHC), perform these procedures with center-link set to **D**. When setup and calibration are complete, adjust center-link back to desired header angle. For instructions, refer to Header Angle in header operator's manual for instructions.

#### **WARNING**

Clear the area of other persons, pets etc. Keep children away from machinery. Walk around the machine to be sure no one is under, on, or close to it.

#### **NOTE:**

This procedure applies to combines with a software version below 28.00. For instructions on calibrating the AHHC for combines with software version 28.00 or above, refer to *Calibrating the Auto Header Height Control – Case IH Combines with Version 28.00 or Higher Software*, page 229.

#### **NOTE:**

Changes may have been made to the combine controls or display since this document was published. For instructions, refer to the combine operator's manual for updates.

#### **NOTE:**

If header float is set too light, it can prevent calibration of AHHC. You may need to set the float heavier for calibration procedure so header doesn't separate from the float module.

## SETTING UP AUTO HEADER HEIGHT CONTROL

1. Ensure center-link is set to **D**.
2. Ensure all header and float module electrical and hydraulic connections are made.
3. Start the combine engine, but do **NOT** engage separator or feeder house.
4. Locate HEADER CONTROL switch (A) on the right console, and set to HT (this is AHHC mode).
5. Hold the DOWN button for 10 seconds, or until the combine feeder house has been lowered all the way down (the feeder house will stop moving).
6. Push the RAISE button and hold it until the feeder house travels all the way up. It will stop 61 cm (2 ft.) above ground for 5 seconds, then it will resume lift. This is an indication that calibration is successful.

**NOTE:**

If float was set heavier to complete the AHHC calibration procedure, adjust to recommended operating float after the calibration is complete.

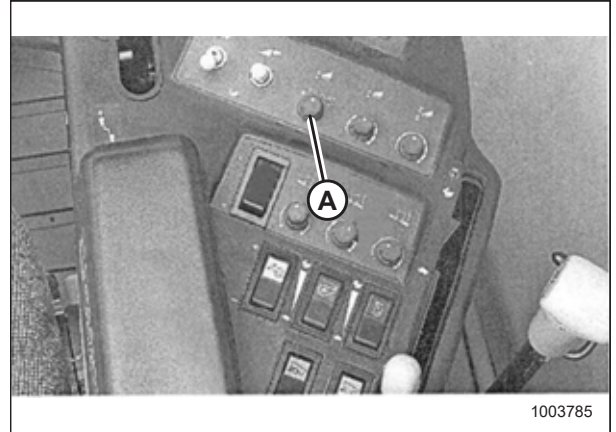

Figure 7.71: Right Console

### Setting Preset Cutting Height – Case 5130/6130/7130, 5140/6140/7140

To set preset cutting height, follow these steps:

**NOTE:**

Changes may have been made to the combine controls or display since this document was published. Refer to the combine operator's manual for updates.

**⚠ WARNING**

Check to be sure all bystanders have cleared the area.

1. Ensure indicator (A) is at position 0 (B) with the header 254–306 mm (10–14 in.) off the ground. If not, the float sensor output voltage should be checked. For instructions, refer to Step 5, page 190.

**NOTE:**

When the header is on the ground, the indicator should be at position 1 (C) for low ground pressure, and at position 4 (D) for high ground pressure. Crop and soil conditions determine the amount of float to use. The ideal setting is as light as possible without header bouncing or missing crop. Operating with heavy settings prematurely wears the cutterbar wearplates.

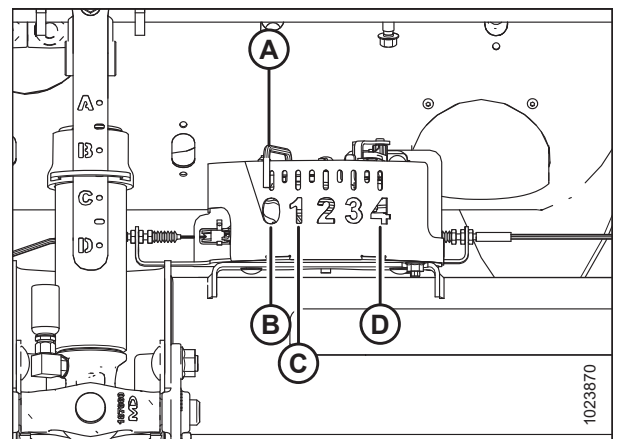

Figure 7.72: Float Indicator Box

## SETTING UP AUTO HEADER HEIGHT CONTROL

2. Engage separator and header.
3. Manually raise or lower the header to the desired cutting height.
4. Press 1 on button (A). A yellow light next to the button will illuminate.

**NOTE:**

When setting presets, always set header position before setting reel position. If header and reel are set at the same time, the reel setting will not be saved.

5. Manually raise or lower the reel to the desired working position.
6. Press 1 on button (A). A yellow light next to the button will illuminate.
7. Manually raise or lower the header to a second desired cutting height.
8. Press 2 on button (A). A yellow light next to the button will illuminate.
9. Manually raise or lower the reel to the desired working position.
10. Press 2 on button (A). A yellow light next to the button will illuminate.



Figure 7.73: Case Combine Console



Figure 7.74: Case Combine Console

Up and down arrows should now appear in MANUAL HEIGHT box (A) on the RUN 1 page on the combine display. This indicates that the auto header height control (AHHC) is functioning.



Figure 7.75: Case Combine Display – Run 1 Page

## SETTING UP AUTO HEADER HEIGHT CONTROL

11. To enable the presets, activate AHHC button (A) to place the header on the ground. To enable the first preset, tap the button once. To enable the second preset, tap the button twice.

To lift the header to maximum working height, hold the SHIFT button on the back of the control handle while tapping AHHC button (A).



Figure 7.76: Case Combine Control Handle

12. The maximum working height can be adjusted on the HEADER SETUP page on the combine display. Enter the desired height in MAXIMUM WORKING HEIGHT field (A).



Figure 7.77: Case Combine Display – Header Setup Page

13. If you need to change the position of one of the presets, you can fine-tune this setting with button (A) on the combine console.



Figure 7.78: Case Combine Console

### 7.1.7 Case IH 7010/8010, 120, 230, 240, and 250 Series Combines

#### Checking Voltage Range from the Combine Cab – Case IH 8010

**NOTE:**

Changes may have been made to the combine controls or display since this document was published. Refer to the combine operator’s manual for updates.

**⚠ WARNING**

Check to be sure all bystanders have cleared the area.

1. Position the header 150 mm (6 in.) above the ground, and unlock the float.
2. Check that float lock linkage is on down stops (washer [A] cannot be moved) at both locations.

**NOTE:**

If the header is not on down stops during the next two steps, the voltage may go out of range during operation causing a malfunction of the AHHC system.

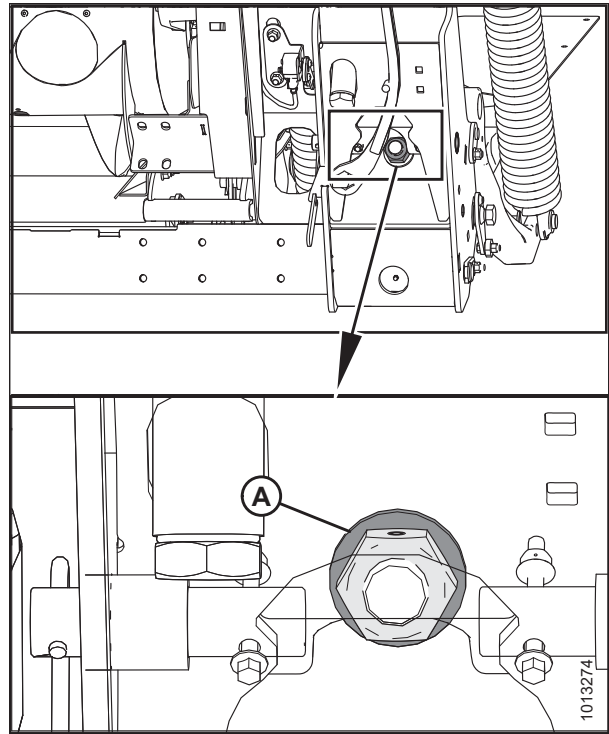

Figure 7.79: Float Lock

3. Adjust cable take-up bracket (B) (if necessary) until pointer (A) on float indicator is on 0.

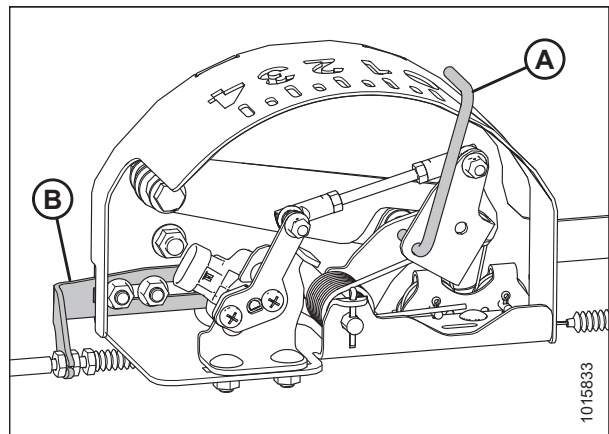

Figure 7.80: Float Indicator Box



**SETTING UP AUTO HEADER HEIGHT CONTROL**

4. Ensure header float is unlocked.
5. Select DIAG (A) on the Universal display MAIN screen. The DIAG screen displays.

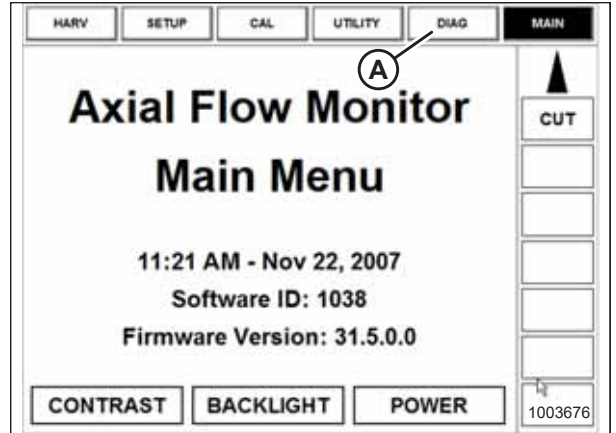

Figure 7.81: Case 8010 Combine Display

6. Select SUB SYSTEM (A). The SUB SYSTEM screen displays.

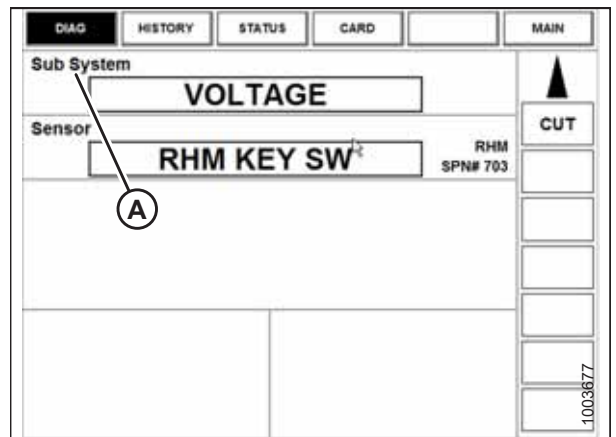

Figure 7.82: Case 8010 Combine Display

7. Select HDR HEIGHT/TILT (A). The SENSOR screen displays.

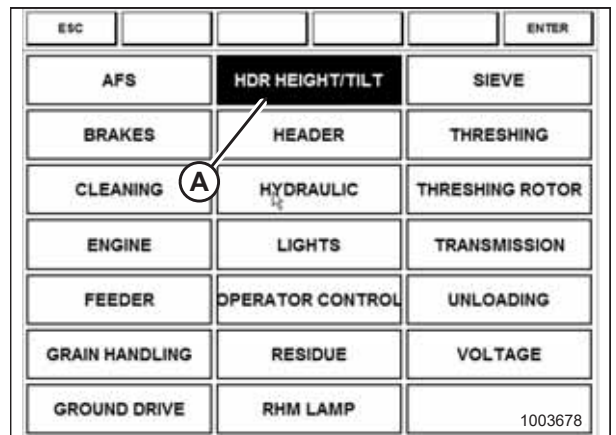

Figure 7.83: Case 8010 Combine Display

## SETTING UP AUTO HEADER HEIGHT CONTROL

8. Select LEFT SEN (A). The exact voltage is displayed. Raise and lower the header to see the full range of voltage readings.

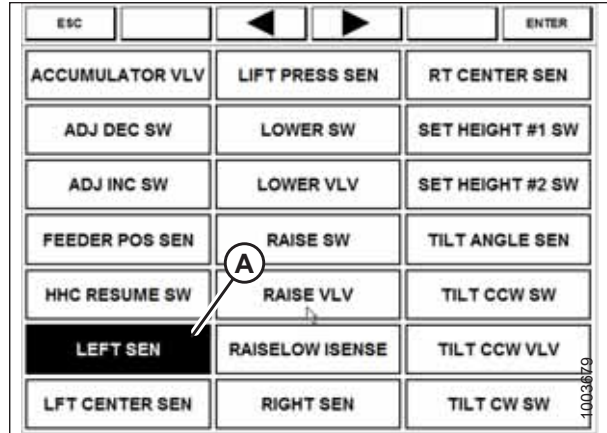

Figure 7.84: Case 8010 Combine Display

9. If the sensor voltage is not within the low and high limits, or if the range between the low and high limits is insufficient, adjust the voltage limits. For instructions, refer to *Adjusting Voltage Limits – One-Sensor System*, page 194.

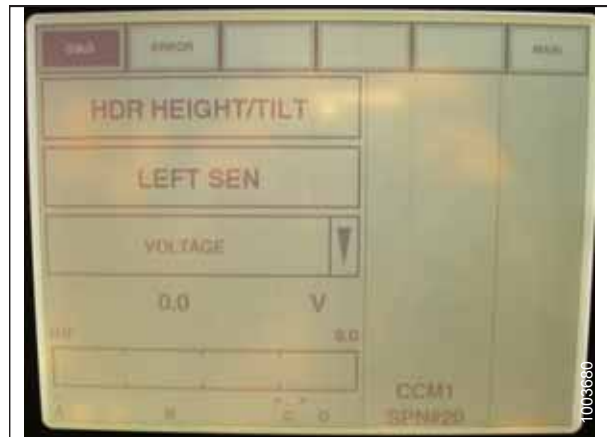

Figure 7.85: Case 8010 Combine Display

### Setting Header Controls – Case IH 8010

The following procedure applies to Case IH 8010 combines without a shift button on the control handle.

The REEL FORE-AFT switches (A) also control header fore-aft tilt if header is equipped with the fore-aft tilt option. The switches can be configured to allow the Operator to swap between reel fore-aft and header fore-aft tilt.

To set the header controls, follow these steps:

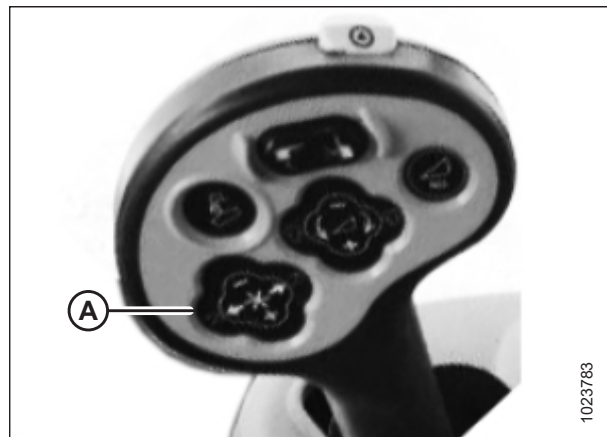

Figure 7.86: Case Combine Controls

## SETTING UP AUTO HEADER HEIGHT CONTROL

- To swap between reel fore-aft controls and header fore-aft tilt controls, go to the LAYOUT tab, select FORE/AFT CONTROL (A) from the legend, and place it on one of the operator-configurable screens (HARV1, HARV2, HARV3) or ADJUST under the RUN menu.

**NOTE:**

H F/A (B) is displayed on the status bar on the right of the screen when HEADER is selected with the FORE/AFT CONTROL.

- If HEADER is selected with the FORE/AFT CONTROL, press the reel aft button on the control handle to tilt the header rearward, or press the reel fore button on the control handle to tilt the header forward.

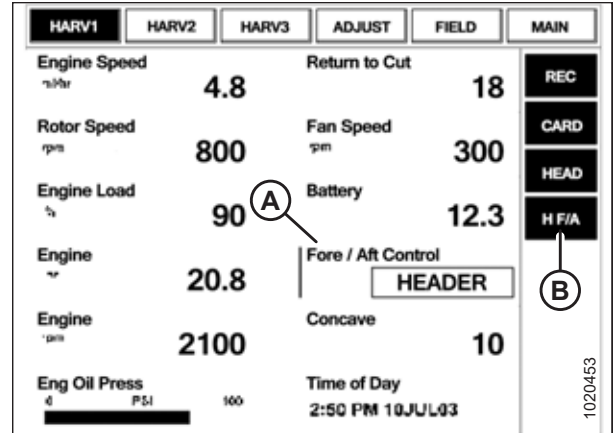

Figure 7.87: Case Combine Display

### Checking Voltage Range from the Combine Cab – Case IH 7010/8010, 120, 230, 240, and 250 Series Combines

**NOTE:**

Changes may have been made to the combine controls or display since this document was published. Refer to the combine operator's manual for updates.

**WARNING**

Check to be sure all bystanders have cleared the area.

- Position the header 150 mm (6 in.) above the ground, and unlock the float.
- Check that float lock linkage is on down stops (washer [A] cannot be moved) at both locations.

**NOTE:**

If the header is not on down stops during the next two steps, the voltage may go out of range during operation causing a malfunction of the auto header height control (AHHC) system.

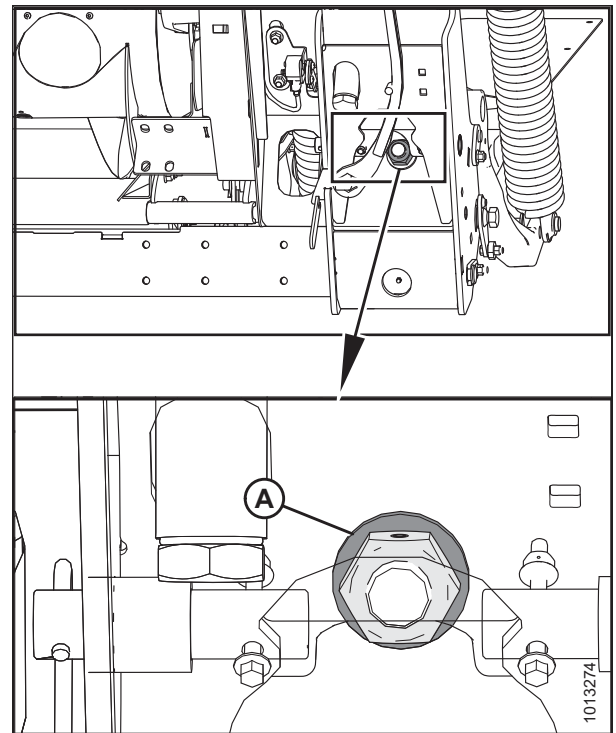

Figure 7.88: Float Lock

## SETTING UP AUTO HEADER HEIGHT CONTROL

- Adjust cable take-up bracket (B) (if necessary) until pointer (A) on float indicator is on **0**.

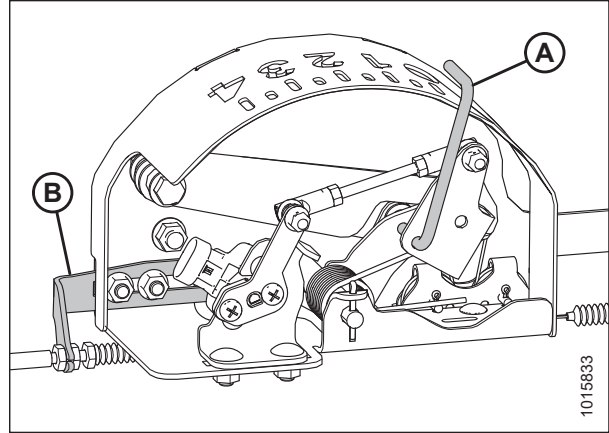

Figure 7.89: Float Indicator Box

- Ensure header float is unlocked.
- Select DIAGNOSTICS (A) on the MAIN page. The DIAGNOSTICS page opens.
- Select SETTINGS. The SETTINGS page opens.

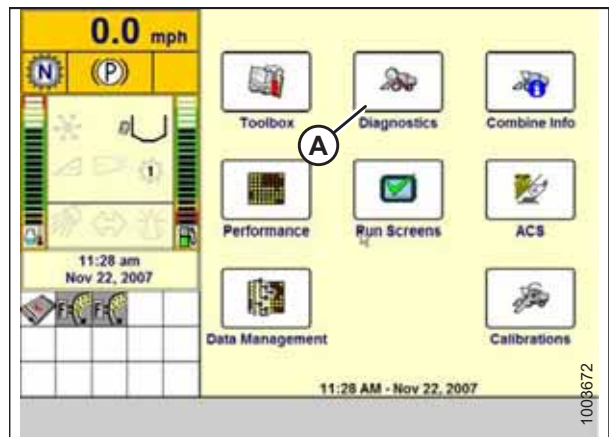

Figure 7.90: Case IH Combine Display

- Select GROUP arrow (A). The GROUP dialog box opens.

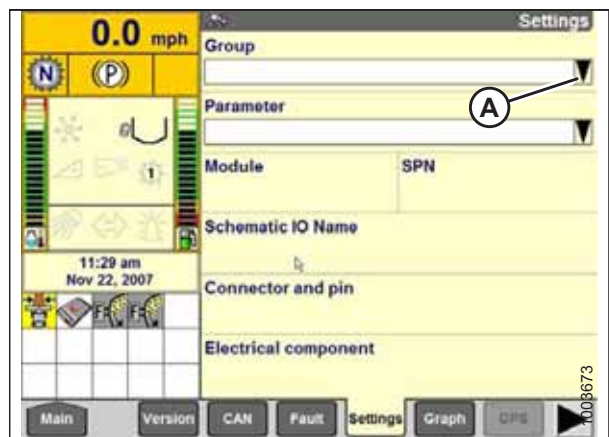

Figure 7.91: Case IH Combine Display

## SETTING UP AUTO HEADER HEIGHT CONTROL

8. Select HEADER HEIGHT/TILT (A). The PARAMETER page opens.

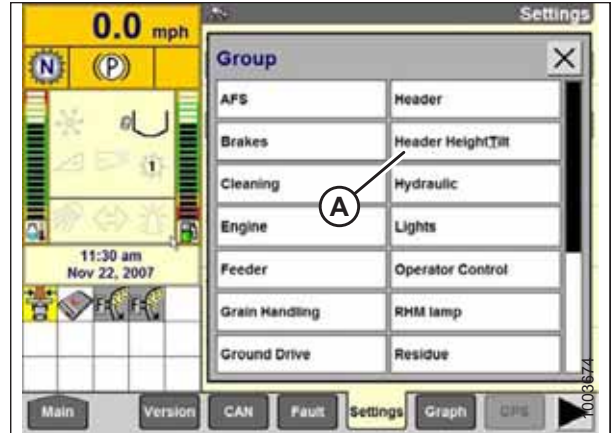

Figure 7.92: Case IH Combine Display

9. Select LEFT HEADER HEIGHT SEN (A), and then select GRAPH button (B). The exact voltage is displayed at top of page. Raise and lower the header to see the full range of voltage readings.
10. If the sensor voltage is not within the low and high limits, or if the range between the low and high limits is insufficient, adjust the voltage limits. For instructions, refer to *Adjusting Voltage Limits – One-Sensor System, page 194*.

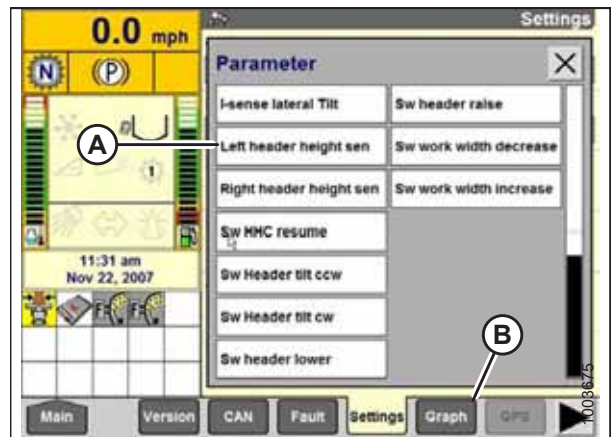

Figure 7.93: Case IH Combine Display

### *Calibrating the Auto Header Height Control – Case IH 7010/8010,120, 230, 240, and 250 Series Combines*

For best performance of the auto header height control (AHHC), perform these procedures with the center-link set to **D**. When setup and calibration are complete, adjust the center-link back to desired header angle. For instructions, refer to the header operator's manual.

#### **! WARNING**

Clear the area of other persons, pets etc. Keep children away from machinery. Walk around the machine to be sure no one is under, on, or close to it.

#### **NOTE:**

This procedure applies to combines with a software version below 28.00. For instructions on calibrating the AHHC for combines with software version 28.00 or above, refer to *Calibrating the Auto Header Height Control – Case IH Combines with Version 28.00 or Higher Software, page 229*.

#### **NOTE:**

Changes may have been made to the combine controls or display since this document was published. Refer to the combine operator's manual for updates.

## SETTING UP AUTO HEADER HEIGHT CONTROL

### NOTE:

If header float is set too light, it can prevent calibration of AHHC. You may need to set the float heavier for calibration procedure so header doesn't separate from the float module.

1. Ensure center-link is set to **D**.
2. Ensure all header and float module electrical and hydraulic connections are made.
3. Select TOOLBOX (A) on the MAIN page.

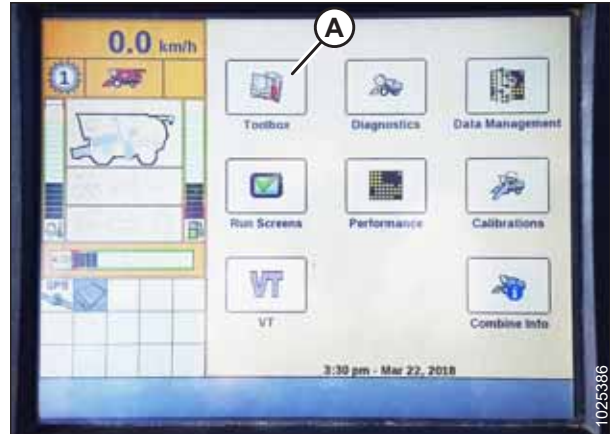

Figure 7.94: Case IH Combine Display

4. Select HEADER tab (A).

### NOTE:

To locate the HEADER tab, you may need to scroll to the right using side arrows (C).

5. Set appropriate HEADER STYLE (B).



Figure 7.95: Case IH Combine Display

6. Set AUTO REEL SPEED SLOPE.

### NOTE:

The AUTO REEL SPEED SLOPE value automatically maintains the speed of the reel relative to ground speed. For example, if the value is set to 133, then the reel will turn be faster than ground speed. The reel should normally be slightly faster than ground speed; however, adjust the value according to crop conditions.

7. Set HEADER PRESSURE FLOAT to NO if equipped, and ensure REEL DRIVE is HYDRAULIC.

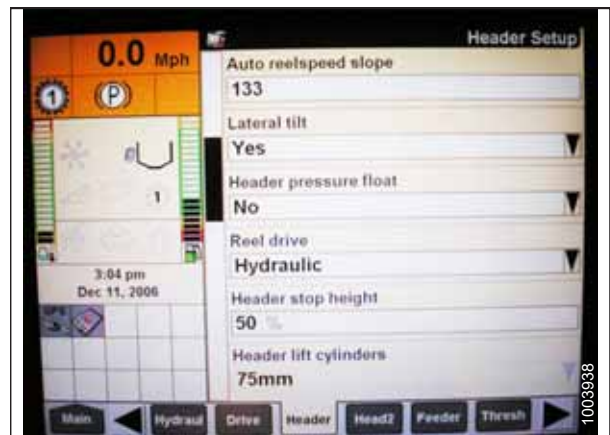

Figure 7.96: Case IH Combine Display

## SETTING UP AUTO HEADER HEIGHT CONTROL

- Install REEL FORE-BACK to YES (if applicable).

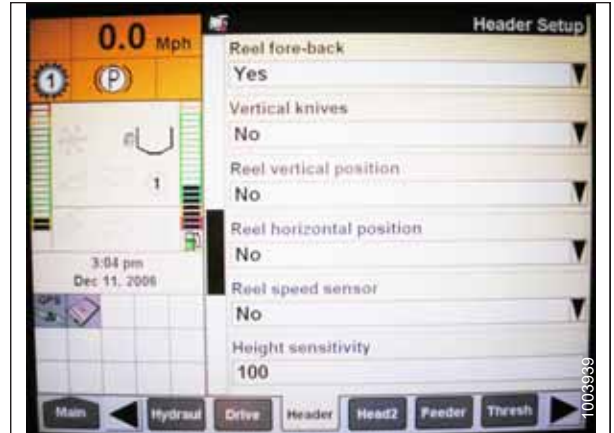

Figure 7.97: Case IH Combine Display

- Locate HHC HEIGHT SENSITIVITY field (A), and set as follows:

- If using a two-sensor system:** Set HHC HEIGHT SENSITIVITY to 250.
- If using a single-sensor system:** Set HHC HEIGHT SENSITIVITY to 180.

**NOTE:**

If hunting occurs during operation, decrease this setting by 20 points at a time until hunting no longer occurs.

- Set HHC TILT SENSITIVITY (B) to 150. Increase or decrease as desired.



Figure 7.98: Case IH Combine Display

- Install FORE/AFT CONTROL and HDR FORE/AFT TILT (if applicable).



Figure 7.99: Case IH Combine Display

## SETTING UP AUTO HEADER HEIGHT CONTROL

12. Press HEAD2 (A) at bottom of page.
13. Ensure HEADER TYPE (B) is DRAPER.

**NOTE:**

If recognition resistor is plugged in to header harness, you will not be able to change this.

14. Set CUTTING TYPE (C) to PLATFORM.
15. Set appropriate HEADER WIDTH (D) and HEADER USAGE (E).

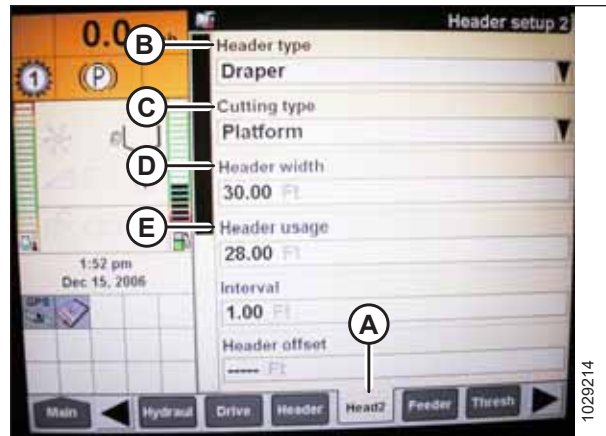

Figure 7.100: Case IH Combine Display

16. From the REEL HEIGHT SENSOR menu, select YES (A).



Figure 7.101: Case IH Combine Display

17. Locate AUTOTILT field (A).

- **If using a two-sensor system:** Select YES in the AUTOTILT field.
- **If using a single-sensor system:** Select NO in the AUTOTILT field.

**NOTE:**

If float was set heavier to complete the AHHC calibration procedure, adjust to recommended operating float after the calibration is complete.



Figure 7.102: Case IH Combine Display



## SETTING UP AUTO HEADER HEIGHT CONTROL

### Calibrating the Auto Header Height Control – Case IH Combines with Version 28.00 or Higher Software

For best performance of the auto header height control (AHHC), perform these procedures with the center-link set to **D**. When setup and calibration are complete, adjust the center-link back to desired header angle. For instructions, refer to the header operator's manual.

#### **WARNING**

Clear the area of other persons, pets etc. Keep children away from machinery. Walk around the machine to be sure no one is under, on, or close to it.

#### **NOTE:**

Changes may have been made to the combine controls or display since this document was published. Refer to the combine operator's manual for updates.

#### **NOTE:**

If header float is set too light, it can prevent calibration of AHHC. You may need to set the float heavier for calibration procedure so header doesn't separate from the float module.

1. Ensure header center-link is set to **D**.
2. Raise header on down stops and unlock float.
3. Place wings in locked position.
4. Select TOOLBOX (A) on the MAIN page.

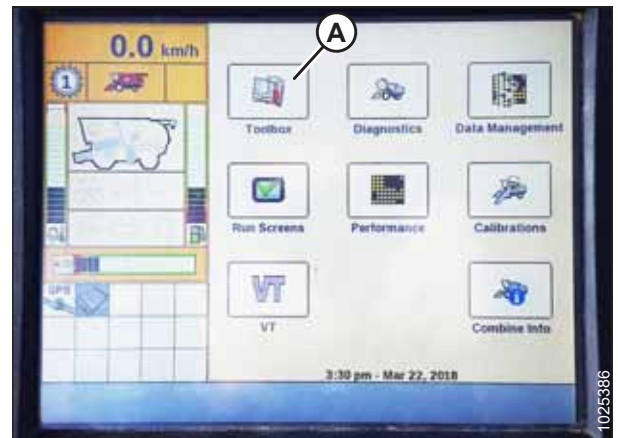

Figure 7.103: Case IH Combine Display

5. Select HEAD 1 tab (A).

#### **NOTE:**

To locate the HEAD 1 tab, you may need to scroll to the right using side arrows (B).

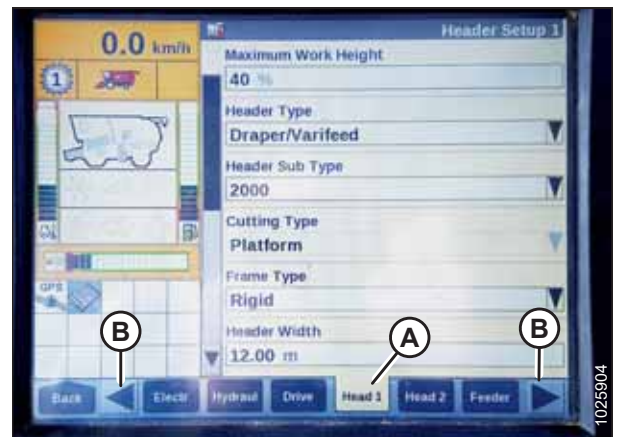

Figure 7.104: Case IH Combine Display

## SETTING UP AUTO HEADER HEIGHT CONTROL

6. Locate the HEADER SUB TYPE field.
7. Select 2000 (A).



Figure 7.105: Case IH Combine Display

8. Select HEAD 2 tab (A).
9. In HEADER SENSORS field (B), select ENABLE.
10. In HEADER PRESSURE FLOAT field (C), select NO.
11. In HEIGHT/TILT RESPONSE field (D), select FAST.
12. In AUTO HEIGHT OVERRIDE field (E), select YES.
13. Press down arrow (F) to go to the next page.



Figure 7.106: Case IH Combine Display

14. Locate HHC HEIGHT SENSITIVITY field (A), and set as follows:
  - **If using a single-sensor system:** Set HHC HEIGHT SENSITIVITY to 180.
  - **If using a two-sensor system:** Set HHC HEIGHT SENSITIVITY to 250.

**NOTE:**

If hunting occurs during operation, decrease this setting by 20 points at a time until hunting no longer occurs.

15. Set HHC TILT SENSITIVITY (B) to 150. Increase or decrease as desired.



Figure 7.107: Case IH Combine Display

## SETTING UP AUTO HEADER HEIGHT CONTROL

16. From the REEL HEIGHT SENSOR menu, select YES (A).



Figure 7.108: Case IH Combine Display

17. Locate AUTOTILT field (A).

- **If using a two-sensor system:** Select YES in the AUTOTILT field.
- **If using a single-sensor system:** Select NO in the AUTOTILT field.



Figure 7.109: Case IH Combine Display

### NOTE:

Icons (A) and (B) appear on the monitor only after engaging the separator and header, and then pressing HEADER RESUME button on the control panel.

18. Ensure AUTO HEIGHT icon (A) appears on the monitor and is displayed as shown at location (B). When the header is set for cutting on the ground, this verifies that the combine is correctly using the sensor on the header to sense ground pressure.

### NOTE:

AUTO HEIGHT field (B) may appear on any of the RUN tabs and not necessarily on the RUN 1 tab.



Figure 7.110: Case IH Combine Display

## SETTING UP AUTO HEADER HEIGHT CONTROL

19. Select CALIBRATION on the combine display, and press the right arrow navigation key to enter the information box.
20. Select HEADER (A), and press ENTER. The CALIBRATION dialog box opens.

**NOTE:**

You can use the up and down navigation keys to move between options.



Figure 7.111: Case IH Combine Display

21. Follow the calibration steps in the order in which they appear in the dialog box. As you proceed through the calibration process, the display will automatically update to show the next step.

**NOTE:**

Pressing the ESC key during any of the steps or letting the system sit idle for more than 3 minutes will cause the calibration procedure to stop.

**NOTE:**

Refer to your combine operator's manual for an explanation of any error codes.



Figure 7.112: Case IH Combine Display

22. When all steps have been completed, CALIBRATION SUCCESSFUL message is displayed on the page. Exit the CALIBRATION menu by pressing the ENTER or ESC key.

**NOTE:**

If float was set heavier to complete the AHHC calibration procedure, adjust to recommended operating float after the calibration is complete.

### Checking Reel Height Sensor Voltages – Case IH Combines

#### **WARNING**

Clear the area of other persons, pets etc. Keep children away from machinery. Walk around the machine to be sure no one is under, on, or close to it.

**NOTE:**

Changes may have been made to the combine controls or display since this document was published. Refer to the combine operator's manual for updates.

## SETTING UP AUTO HEADER HEIGHT CONTROL

1. On the main page of the combine display, select DIAGNOSTICS (A). The DIAGNOSTICS page opens.

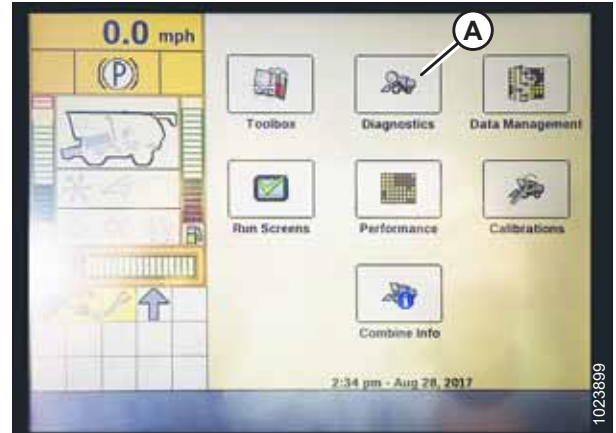

Figure 7.113: Case IH Combine Display

2. Select SETTINGS tab (A). The SETTINGS page opens.
3. From the GROUP menu, select HEADER (B).
4. From the PARAMETER menu, select REEL VERTICAL POSITION (C).



Figure 7.114: Case IH Combine Display

5. Select GRAPH tab (A). The REEL VERTICAL POSITION graph displays.
6. Lower the reel to view high voltage (B). The voltage should be 4.1–4.5 V.
7. Raise the reel to view low voltage (C). The voltage should be 0.5–0.9 V.
8. If either voltage is out of range, refer to [8.1 Checking and Adjusting Reel Height Sensor](#), page 365.

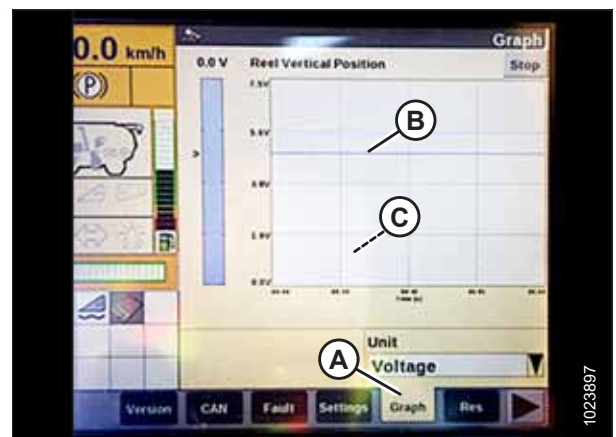

Figure 7.115: Case IH Combine Display

## SETTING UP AUTO HEADER HEIGHT CONTROL

### Setting Preset Cutting Height – Case IH 7010/8010, 120, 230, 240, and 250 Series Combines

To set the preset cutting height, follow these steps:

#### **WARNING**

Clear the area of other persons, pets etc. Keep children away from machinery. Walk around the machine to be sure no one is under, on, or close to it.

#### **NOTE:**

Changes may have been made to the combine controls or display since this document was published. Refer to the combine operator's manual for updates.

1. Ensure indicator (A) is at position 0 (B) with the header 254–306 mm (10–14 in.) off the ground. If not, the float sensor output voltage should be checked. For instructions, refer to Step 5, page 190.

#### **NOTE:**

When the header is on the ground, the indicator should be at position 1 (C) for low ground pressure, and at position 4 (D) for high ground pressure. Crop and soil conditions determine the amount of float to use. The ideal setting is as light as possible without header bouncing or missing crop. Operating with heavy settings prematurely wears the cutterbar wearplates.

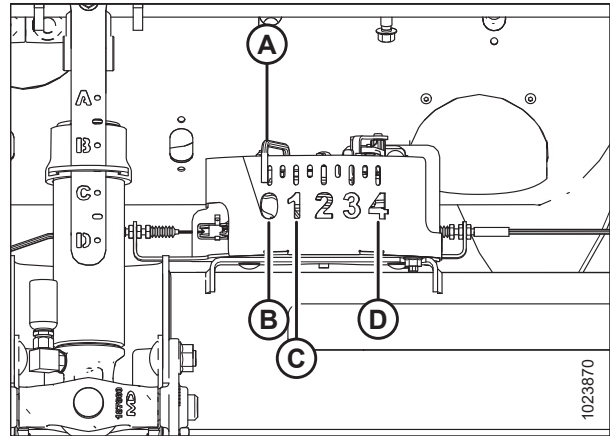

Figure 7.116: Float Indicator Box

2. Engage separator and header.
3. Manually raise or lower header to a desired cutting height.
4. Press SET #1 switch (A). Light (C) beside switch (A) will illuminate.

#### **NOTE:**

Use switch (E) for fine adjustments.

#### **NOTE:**

When setting presets, always set header position before setting reel position. If header and reel are set at the same time, the reel setting will not save.

5. Manually raise or lower the reel to the desired position.
6. Press SET #1 switch (A). Light (C) beside switch (A) will illuminate.
7. Manually raise or lower the header to a second desired cutting height.
8. Press SET #2 switch (B). Light (D) beside switch (B) will illuminate.
9. Manually raise or lower the reel to a second desired working position.
10. Press SET #2 switch (B). Light (D) beside switch (B) will illuminate.

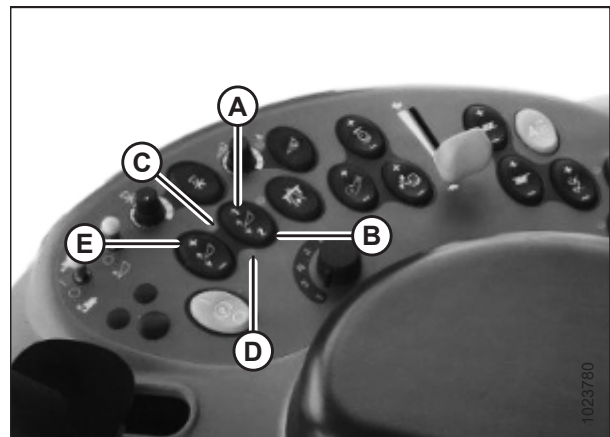

Figure 7.117: Case Combine Controls

## SETTING UP AUTO HEADER HEIGHT CONTROL

11. To swap between set points, press HEADER RESUME (A).
12. To raise header at headlands, press and hold SHIFT button (B) at the back of the control handle and press HEADER RESUME switch (A). To lower header, press HEADER RESUME switch (A) once to return to header preset height.

**NOTE:**

Pressing HEADER RAISE/LOWER switches (C) and (D) disengages AUTO HEIGHT mode. Press HEADER RESUME (A) to re-engage.



Figure 7.118: Case Combine Controls

### 7.1.8 Challenger and Massey Ferguson 6 and 7 Series Combines

#### Checking Voltage Range from the Combine Cab – Challenger and Massey Ferguson



**WARNING**

Clear the area of other persons, pets etc. Keep children away from machinery. Walk around the machine to be sure no one is under, on, or close to it.

**NOTE:**

Changes may have been made to the combine controls or display since this document was published. Refer to the combine operator's manual for updates.

1. Position the header 150 mm (6 in.) above the ground, and unlock the float.
2. Check that float lock linkage is on down stops (washer [A] cannot be moved) at both locations.

**NOTE:**

If the header is not on down stops during the next two steps, the voltage may go out of range during operation, causing a malfunction of the auto header height control (AHHC) system.

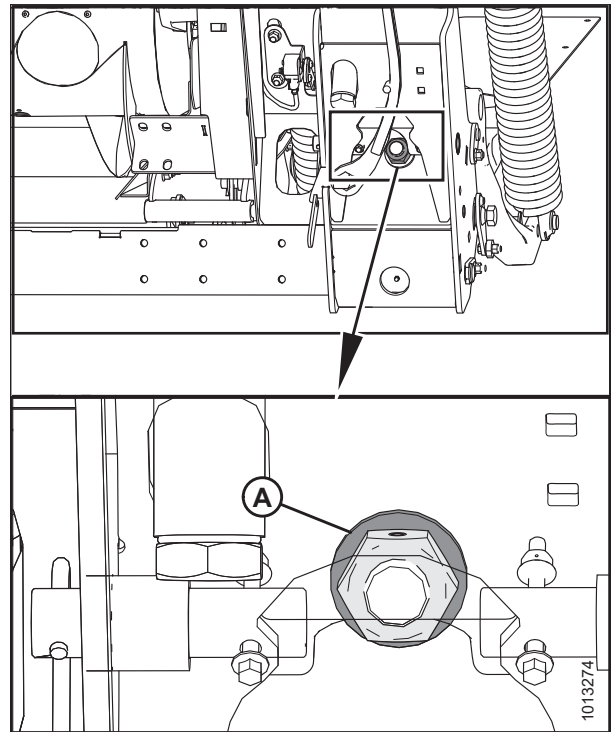

Figure 7.119: Float Lock

## SETTING UP AUTO HEADER HEIGHT CONTROL

- Adjust cable take-up bracket (B) (if necessary) until float indicator pointer (A) is on 0.

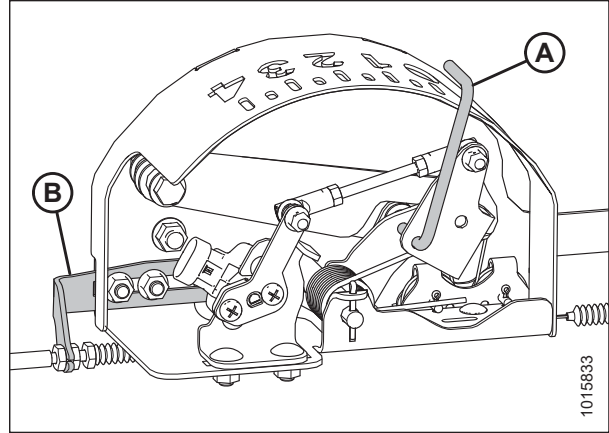

Figure 7.120: Float Indicator Box

- Go to the FIELD page on the combine monitor, and then press the diagnostics icon. The MISCELLANEOUS page displays.
- Press VMM DIAGNOSTIC button (A). The VMM DIAGNOSTIC page displays.

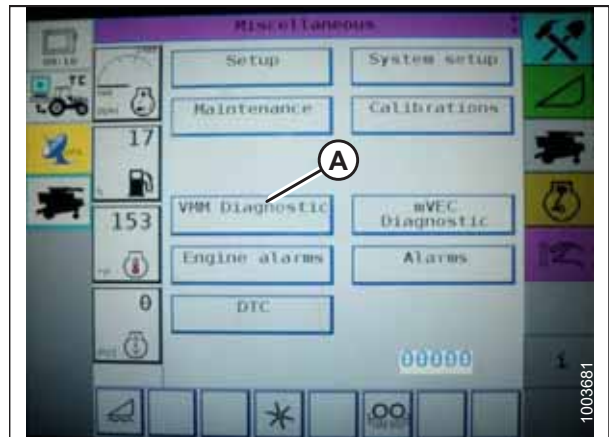

Figure 7.121: Challenger Combine Display

- Go to ANALOG IN tab (A), and then select VMM MODULE 3 by pressing the text box below the four tabs. The voltage from the AHC sensor is now displayed on page as HEADER HEIGHT RIGHT POT and HEADER HEIGHT LEFT POT. The readings may be slightly different.



Figure 7.122: Challenger Combine Display



## SETTING UP AUTO HEADER HEIGHT CONTROL

- Fully lower the combine feeder house (float module should be fully separated from the header).

**NOTE:**

You may need to hold the HEADER DOWN switch for a few seconds to ensure the feeder house is fully lowered.

- Read voltage.
- Raise the header until it is 150 mm (6 in.) off the ground.
- Read voltage.
- If the sensor voltage is not within the low and high limits, or if the range between the low and high limits is insufficient, adjust the voltage limits. For instructions, refer to *Adjusting Voltage Limits – One-Sensor System, page 194* or *Adjusting Voltage Limits – Two-Sensor System, page 195*.



Figure 7.123: Challenger Combine Display

### Engaging the Auto Header Height Control – Challenger and Massey Ferguson

**NOTE:**

Changes may have been made to the combine controls or display since this document was published. Refer to the combine operator's manual for updates.

The following system components are required in order for the auto header height control (AHC) to work:

- Main module (PCB board) and header driver module (PCB board) mounted in card box in fuse panel module (FP)
- Multifunction control handle operator inputs
- Operator inputs mounted in the control console module (CC) panel

**NOTE:**

In addition to the above components, the electrohydraulic header lift control valve is an integral part of the system.

Engage the AHC as follows:

- Scroll through the header control options on the combine display using the header control switch until AHC icon (A) is displayed in the first message box. The AHC will adjust the header height in relation to the ground according to the height setting and sensitivity setting.



Figure 7.124: Challenger Combine Display

### Calibrating the Auto Header Height Control – Challenger and Massey Ferguson



**WARNING**

Clear the area of other persons, pets etc. Keep children away from machinery. Walk around the machine to be sure no one is under, on, or close to it.

## SETTING UP AUTO HEADER HEIGHT CONTROL

### NOTE:

For best performance of the auto header height control (AHHC) system, perform these procedures with the center-link set to **D**. When setup and calibration are complete, adjust the center-link back to desired header angle. For instructions, refer to Header Angle in the header operator's manual.

### NOTE:

Changes may have been made to the combine controls or display since this document was published. Refer to the combine operator's manual for updates.

### NOTE:

If the header float is set too light, it can prevent AHHC calibration. You may need to set the float heavier for the calibration procedure so the header doesn't separate from the float module.

1. Ensure center-link is set to **D**.
2. On the FIELD screen, press DIAGNOSTICS icon (A). The MISCELLANEOUS screen appears.



Figure 7.125: Challenger Combine Display

3. Press CALIBRATIONS button (A). The CALIBRATIONS screen appears.

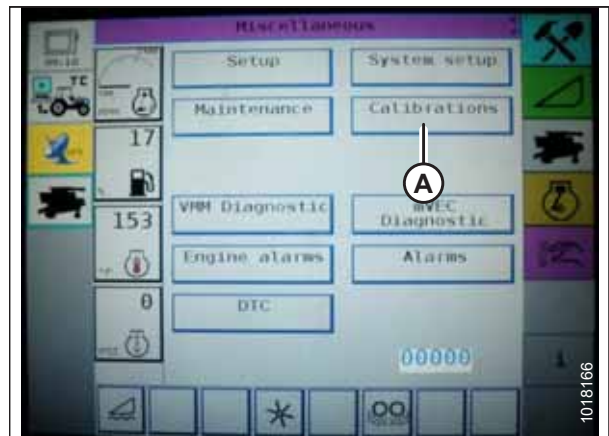

Figure 7.126: Challenger Combine Display

## SETTING UP AUTO HEADER HEIGHT CONTROL

4. Press HEADER button (A). The HEADER CALIBRATION screen displays a warning.

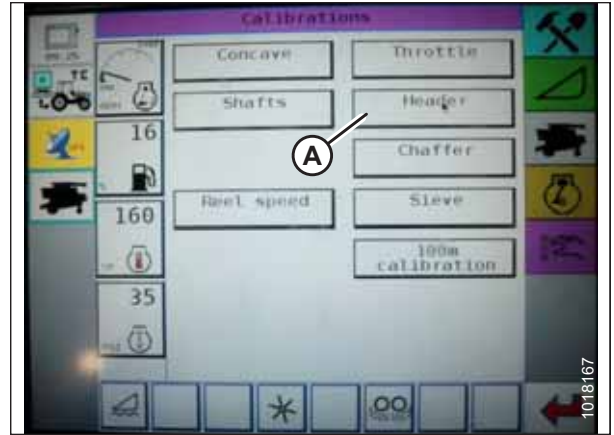

Figure 7.127: Challenger Combine Display

5. Read the warning message, and then press the green check mark button.



Figure 7.128: Challenger Combine Display

6. Follow the on-screen prompts to complete calibration.

### NOTE:

The calibration procedure can be canceled at any time by pressing the cancel button in the bottom right corner of the screen. While the header calibration is running, the calibration can also be canceled by using the UP, DOWN, TILT RIGHT, or TILT LEFT buttons on the control handle.

### NOTE:

If the combine does not have HEADER TILT installed or if it is inoperable, you may receive warnings during calibration. Press the green check mark if these warnings appear. This will not affect the AHHC calibration.

### NOTE:

If the float was set heavier to complete the AHHC calibration procedure, adjust to the recommended operating float after the calibration is complete.

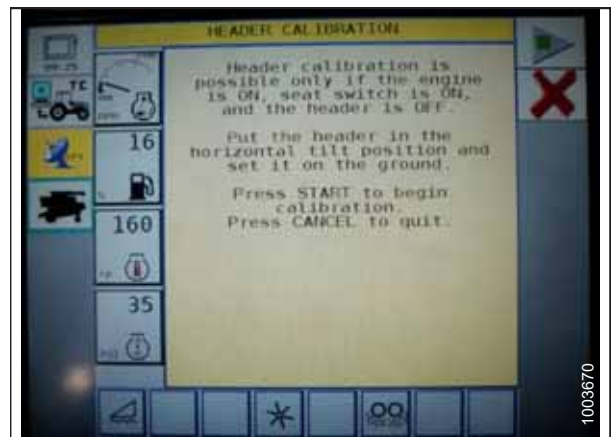

Figure 7.129: Challenger Combine Display

## SETTING UP AUTO HEADER HEIGHT CONTROL

### *Adjusting the Header Height – Challenger and Massey Ferguson*

Once the auto header height control (AHHC) is activated, press and release the HEADER LOWER button on the control handle. The AHHC will automatically lower the header to the selected height setting.

#### **WARNING**

Clear the area of other persons, pets etc. Keep children away from machinery. Walk around the machine to be sure no one is under, on, or close to it.

#### **NOTE:**

Changes may have been made to the combine controls or display since this document was published. Refer to the combine operator's manual for updates.

You can adjust the selected AHHC height using HEIGHT ADJUSTMENT knob (A) on the control console. Turning the knob clockwise increases the selected height, and turning the knob counterclockwise decreases the selected height.



Figure 7.130: Height Adjustment Knob on the Combine Control Console

### *Adjusting the Header Raise/Lower Rate – Challenger and Massey Ferguson*

#### **NOTE:**

Changes may have been made to the combine controls or display since this document was published. Refer to the combine operator's manual for updates.

1. Press Header icon (A) on the FIELD screen. The HEADER screen displays.

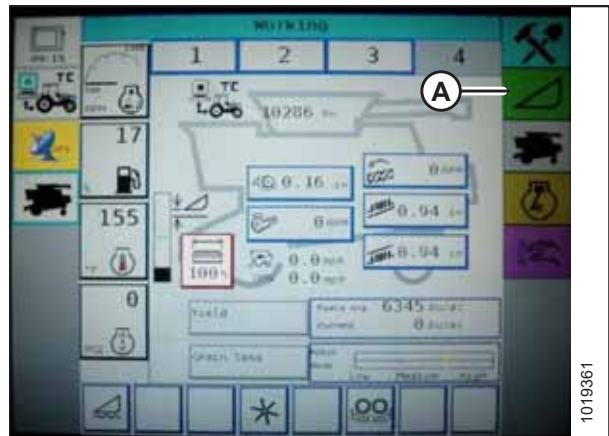

Figure 7.131: Challenger Combine Display

## SETTING UP AUTO HEADER HEIGHT CONTROL

2. Press HEADER CONTROL (A). The HEADER CONTROL screen displays.

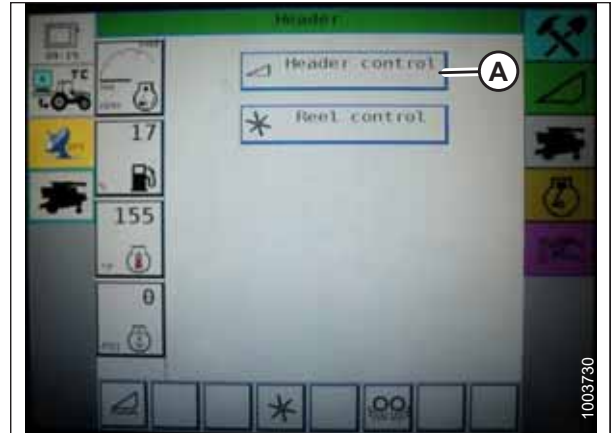

Figure 7.132: Challenger Combine Display

3. Go to the TABLE SETTINGS tab.
4. Press up arrow on MAX UP PWM to increase percentage number and increase raise speed. Press down arrow on MAX UP PWM to decrease percentage number and decrease raise speed.
5. Press up arrow on MAX DOWN PWM to increase percentage number and increase lower speed. Press down arrow on MAX DOWN PWM to decrease percentage number and decrease lower speed.

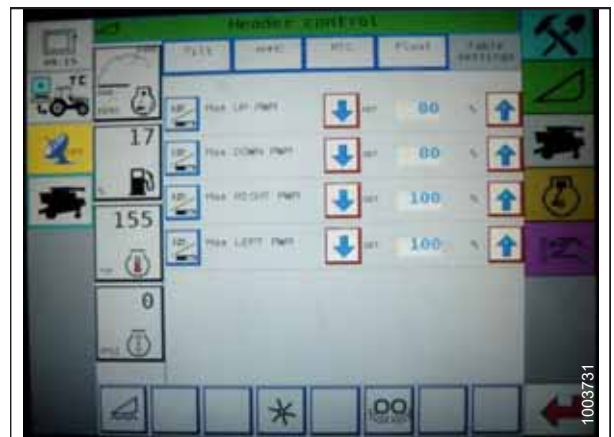

Figure 7.133: Challenger Combine Display

### *Setting the Sensitivity of the Auto Header Height Control – Challenger and Massey Ferguson*

The sensitivity adjustment controls the distance the cutterbar must travel up or down before the auto header height control (AHC) reacts and raises or lowers the feeder house. When the sensitivity is set to maximum, only small changes in ground height are needed to cause the feeder house to raise or lower. When the sensitivity is set to minimum, large changes in the ground height are needed to cause the feeder house to raise or lower.

### **WARNING**

**Clear the area of other persons, pets etc. Keep children away from machinery. Walk around the machine to be sure no one is under, on, or close to it.**

#### **NOTE:**

Changes may have been made to the combine controls or display since this document was published. Refer to the combine operator's manual for updates.

1. Press the HEADER icon on the FIELD screen. The HEADER screen appears.

## SETTING UP AUTO HEADER HEIGHT CONTROL

2. Press HEADER CONTROL button (A). The HEADER CONTROL screen appears. You can adjust sensitivity on this screen using the up and down arrows.



Figure 7.134: Challenger Combine Display

3. Adjust the sensitivity to the maximum setting.
4. Activate the AHHC, and press the HEADER LOWER button on the control handle.
5. Decrease the sensitivity until the feeder house remains steady and does not bounce up and down.

**NOTE:**

This is the maximum sensitivity and is only an initial setting. The final setting must be made in the field, as the system reaction will vary with changing surfaces and operating conditions.

**NOTE:**

If maximum sensitivity is not needed, a less sensitive setting will reduce the frequency of header height corrections and component wear. Partially opening the accumulator valve will cushion the action of the header lift cylinders and reduce header hunting.



Figure 7.135: Challenger Combine Display

### 7.1.9 CLAAS 500 Series Combines

#### *Calibrating the Auto Header Height Control – CLAAS 500 Series*

For best performance of the auto header height control (AHHC), perform these procedures with the center-link set to **D**. When setup and calibration are complete, adjust the center-link back to desired header angle. For instructions, refer to Header Angle in the header operator's manual for instructions.

**NOTE:**

Changes may have been made to the combine controls or display since this document was published. Refer to the combine operator's manual for updates.

**NOTE:**

If header float is set too light, it can prevent calibration of AHHC. You may need to set the float heavier for calibration procedure so header doesn't separate from the float module.

1. Ensure center-link is set to **D**.

## SETTING UP AUTO HEADER HEIGHT CONTROL

- Use < key (A) or > key (B) to select AUTO HEADER, and press OK key (C). The E5 screen displays whether the automatic header height is on or off.

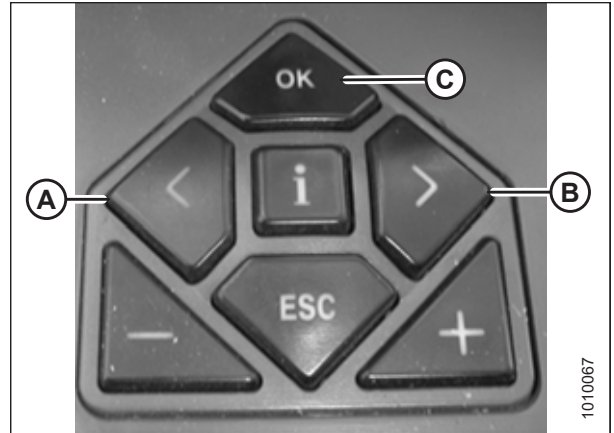

Figure 7.136: CLAAS Combine Controls

- Use – key (A) or + key (B) to turn the AHHC on, and press OK key (C).
- Engage the threshing mechanism and the header.

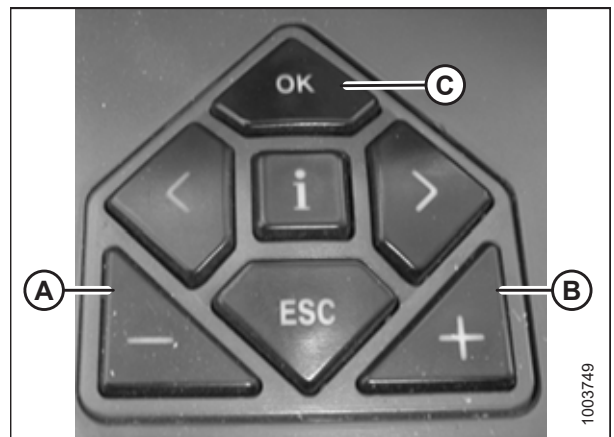

Figure 7.137: CLAAS Combine Controls

- Use the < or > key to select CUTT. HEIGHT LIMITS, and press the combine controls OK key.
- Follow the procedure displayed on the screen to program the upper and lower limits of the header into the CEBIS.

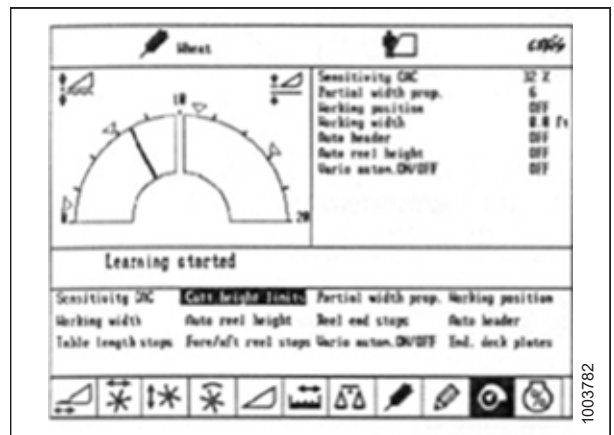

Figure 7.138: CLAAS Combine Display

## SETTING UP AUTO HEADER HEIGHT CONTROL

- Use the < or > key to select SENSITIVITY CAC, and press the combine controls OK key.

**NOTE:**

Setting the sensitivity of the AHHC system affects the reaction speed of the AHHC on the header.

- Use the – key or the + key to change the setting of the reaction speed, and press the combine controls OK key.

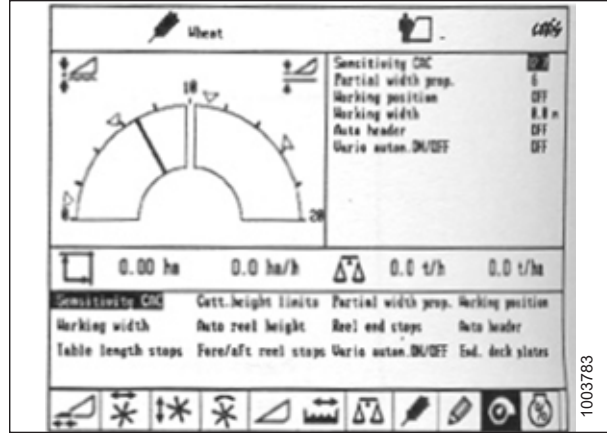

Figure 7.139: CLAAS Combine Display

- Use line (A) or value (B) to determine the sensitivity setting.

**NOTE:**

The setting can be adjusted from 0–100%. When sensitivity is adjusted to 0%, the signals from the sensing bands have no effect on the automatic cutting height adjustment. When sensitivity is adjusted to 100%, the signals from the sensing bands have maximum effect on the automatic cutting height adjustment. The recommended starting point is 50%.

**NOTE:**

If float was set heavier to complete the AHHC calibration procedure, adjust to recommended operating float after the calibration is complete.

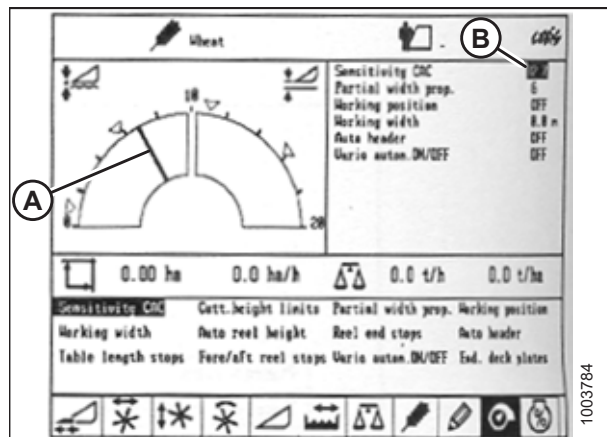

Figure 7.140: CLAAS Combine Display

### Setting Cutting Height – CLAAS 500 Series

Cutting heights can be programmed into the preset cutting height and auto contour systems. Use the preset cutting height system for cutting heights above 150 mm (6 in.), and use the auto contour system for cutting heights below 150 mm (6 in.).

#### Setting Preset Cutting Height – CLAAS 500 Series

### WARNING

Check to be sure all bystanders have cleared the area.

**NOTE:**

Changes may have been made to the combine controls or display since this document was published. Refer to the combine operator's manual for updates.

- Start the engine.
- Activate the machine enable switch.
- Engage the threshing mechanism.
- Engage the header.



## SETTING UP AUTO HEADER HEIGHT CONTROL

5. Briefly press button (A) in order to activate the auto contour system, or briefly press button (B) in order to activate the preset cutting height system.

### NOTE:

Button (A) is used only with auto header height control (AHHC) function. Button (B) is used only with the return to cut function.



Figure 7.141: Control Handle Buttons

6. Use < key (C) or > key (D) to select the CUTTING HEIGHT screen, and press OK key (E).
7. Use – key (A) or + key (B) to set the desired cutting height. An arrow indicates the selected cutting height on the scale.

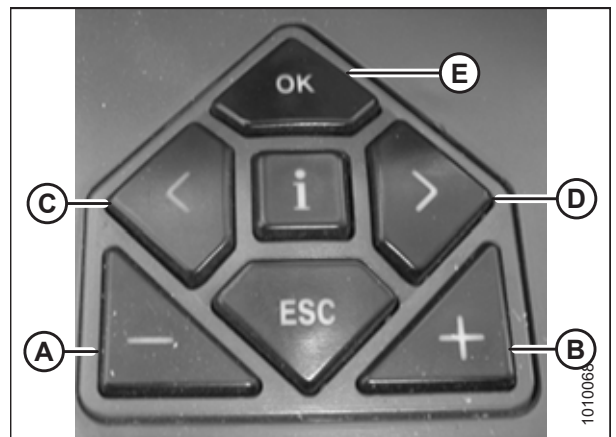

Figure 7.142: CLAAS Combine Controls

8. Briefly press button (A) or button (B) in order to select the set point.
9. Repeat Step 7, page 245 for the set point.



Figure 7.143: Control Handle Buttons

### Setting Cutting Height Manually – CLAAS 500 Series



### WARNING

Check to be sure all bystanders have cleared the area.

## SETTING UP AUTO HEADER HEIGHT CONTROL

### NOTE:

Changes may have been made to the combine controls or display since this document was published. Refer to the combine operator's manual for updates.

1. Use button (A) to raise the header, or button (B) to lower the header to the desired cutting height.
2. Press and hold button (C) for 3 seconds to store the cutting height into the CEBIS (an alarm will sound when the new setting has been stored).
3. Program a second set point, if desired, by using button (A) to raise the header, or button (B) to lower the header to the desired cutting height, and briefly press button (C) to store the second set point into the CEBIS (an alarm will sound when the new setting has been stored).

### NOTE:

For above-the-ground cutting, repeat Step 1, page 246, and use button (D) instead of button (C) while repeating Step 2, page 246.



Figure 7.144: Control Handle Buttons

### Setting the Sensitivity of the Auto Header Height Control – CLAAS 500 Series

The sensitivity adjustment controls the distance the cutterbar must travel up or down before the auto header height control (AHHC) reacts and raises or lowers the feeder house. When the sensitivity is set to maximum, only small changes in ground height are needed to cause the feeder house to raise or lower. When the sensitivity is set to minimum, large changes in the ground height are needed to cause the feeder house to raise or lower.

### NOTE:

The upper and lower limits of the header must be programmed into the CEBIS before adjusting the sensitivity of the AHHC system. The setting can be adjusted from 0–100%. When sensitivity is adjusted to 0%, the signals from the sensing bands have no effect on the automatic cutting height adjustment. When sensitivity is adjusted to 100%, the signals from the sensing bands have maximum effect on the automatic cutting height adjustment. The recommended starting point is 50%.

### NOTE:

Changes may have been made to the combine controls or display since this document was published. Refer to the combine operator's manual for updates.

1. Use < key (C) or > key (D) to select SENSITIVITY CAC, and press OK key (E).
2. Use – key (A) or + (B) key to change the reaction speed setting, and press OK key (E).

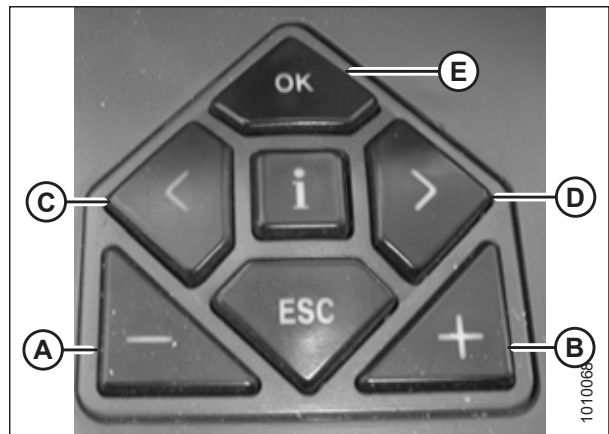

Figure 7.145: CLAAS Combine Controls

**SETTING UP AUTO HEADER HEIGHT CONTROL**

3. Use line (A) or value (B) to determine the sensitivity setting.

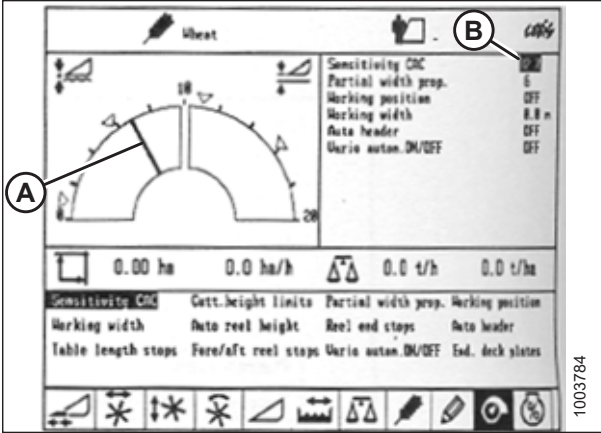
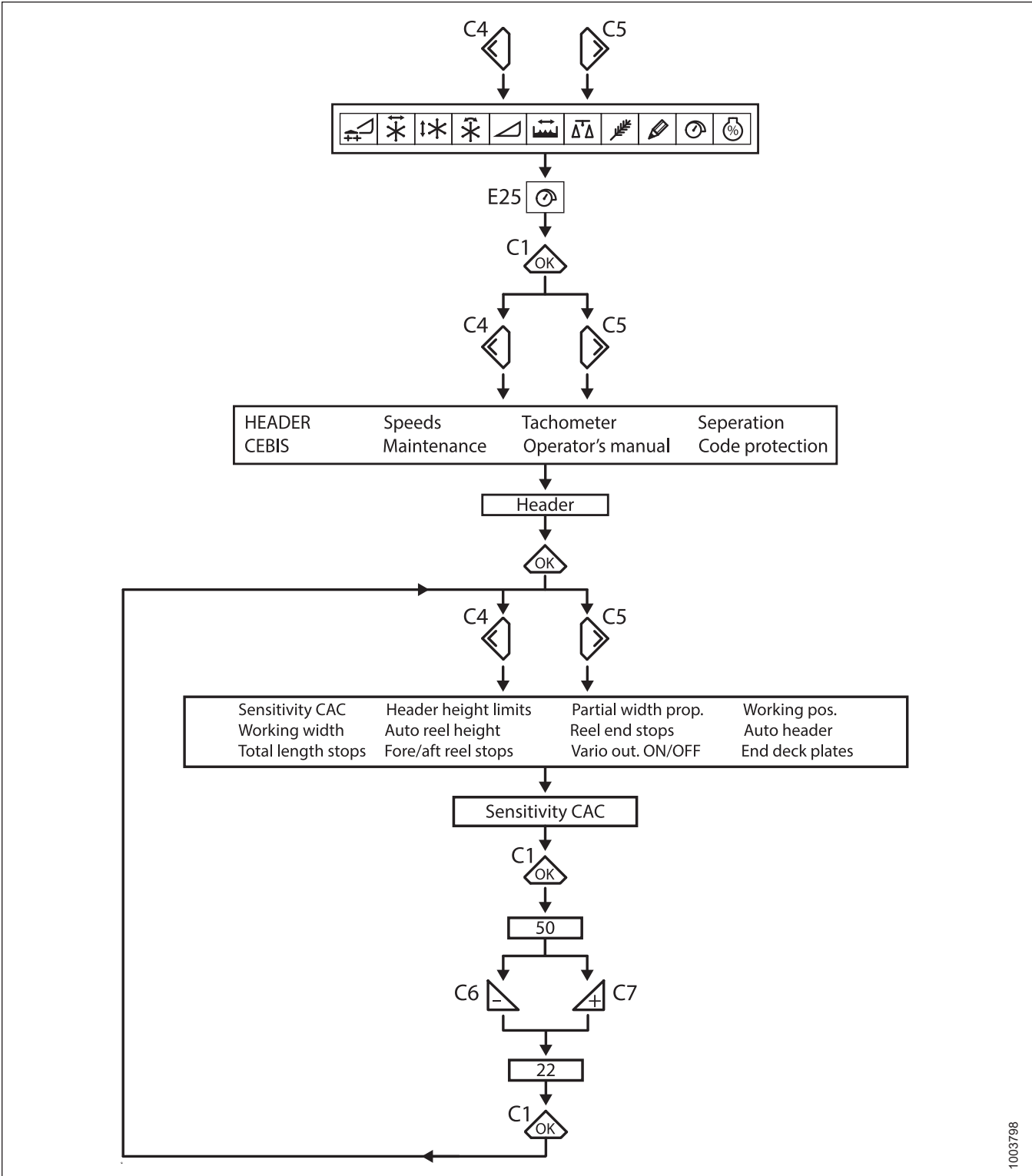

Figure 7.146: CLAAS Combine Display

## SETTING UP AUTO HEADER HEIGHT CONTROL



1003798

**Figure 7.147: Flow Chart for Setting the Sensitivity of the Float Optimizer**

## SETTING UP AUTO HEADER HEIGHT CONTROL

### Adjusting Auto Reel Speed – CLAAS 500 Series

The preset reel speed can be set when the automatic header functions are activated.

#### NOTE:

Changes may have been made to the combine controls or display since this document was published. Refer to the combine operator's manual for updates.

1. Use the < or > key to select REEL WINDOW. Window E15 will display the current advance or retard speed of the reel in relation to the ground speed.

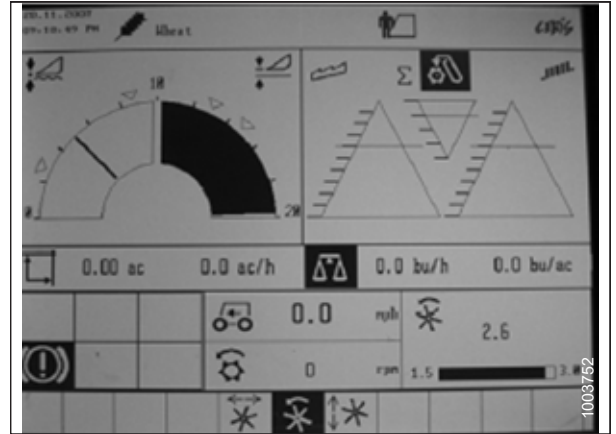

Figure 7.148: CLAAS Combine Display

2. Press OK key (C) to open the REEL SPEED window.
3. Use – key (A) or + key (B) to set the reel speed in relation to the current ground speed. Window E15 will display the selected reel speed.

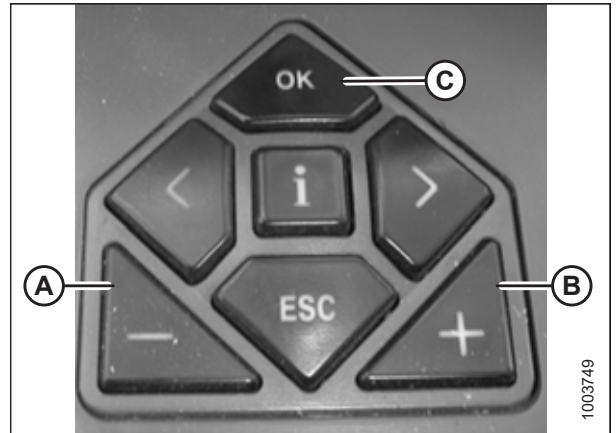

Figure 7.149: CLAAS Combine Controls

4. Manually adjust the reel speed by rotating the rotary switch to reel position (A), and then use the – or + key to set the reel speed.



Figure 7.150: CLAAS Combine Rotary Switch

## SETTING UP AUTO HEADER HEIGHT CONTROL

5. Press and hold button (A) or button (B) for 3 seconds to store the setting into the CEBIS (an alarm will sound when the new setting has been stored).

### NOTE:

Whenever button (A) or button (B) is pressed for 3 seconds, the current positions for reel speed and cutting height are stored.



Figure 7.151: CLAAS Control Handle Buttons

6. Use the < or > key to select the REEL WINDOW. Window E15 will display the current advance or retard speed of the reel in relation to the ground speed.



Figure 7.152: CLAAS Combine Display

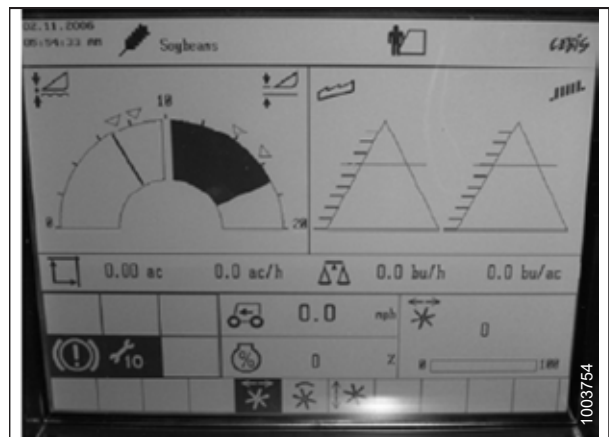

Figure 7.153: CLAAS Combine Display

## SETTING UP AUTO HEADER HEIGHT CONTROL

7. Press OK key (E), and use < key (C) or > key (D) to select the REEL FORE AND AFT window.
8. Use – key (A) or + key (B) to set the reel fore-aft position.

**NOTE:**

Control handle button (A) or button (B) (as shown in Figure 7.155, page 251) can also be used to set the reel fore-aft position.

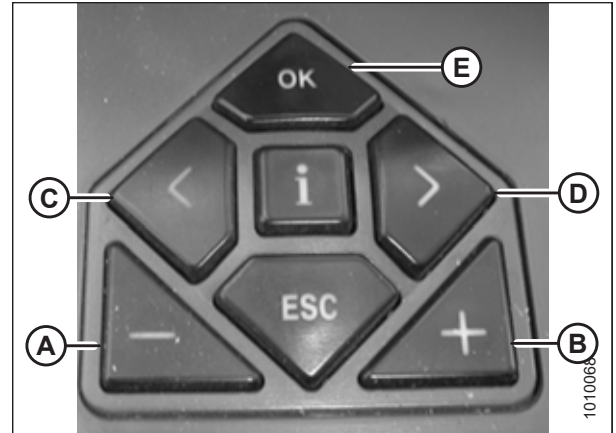

Figure 7.154: CLAAS Combine Controls

9. Press and hold button (A) or button (B) for 3 seconds to store the setting into the CEBIS (an alarm will sound when the new setting has been stored).

**NOTE:**

Whenever button (A) or button (B) is pressed for 3 seconds, the current positions for reel speed and cutting height are stored.



Figure 7.155: CLAAS Control Handle Buttons

### 7.1.10 CLAAS 600 and 700 Series Combines

#### *Calibrating the Auto Header Height Control – CLAAS 600 and 700 Series*

For best performance of the auto header height control (AHHC), perform these procedures with the center-link set to **D**. When setup and calibration are complete, adjust the center-link back to desired header angle. For instructions, refer to Header Angle in the header operator's manual for instructions.

**NOTE:**

Changes may have been made to the combine controls or display since this document was published. Refer to the combine operator's manual for updates.

**NOTE:**

If header float is set too light, it can prevent AHHC calibration. You may need to set the float heavier for calibration procedure so header doesn't separate from the float module.

1. Ensure center-link is set to **D**.
2. Ensure that the header float is unlocked.
3. Place wings in locked position.

## SETTING UP AUTO HEADER HEIGHT CONTROL

4. Use control knob (A) to highlight AUTO CONTOUR icon (B) and press control knob (A) to select it.



Figure 7.156: CLAAS Combine Display, Console, and Control Handle

5. Use control knob (A) to highlight the icon that resembles a header with up and down arrows (not shown), and press control knob (A) to select it. Highlighted header icon (B) will be displayed on the screen.



Figure 7.157: CLAAS Combine Display, Console, and Control Handle

6. Use control knob (A) to highlight the icon that resembles a header with up and down arrows (B), and press control knob (A) to select it.



Figure 7.158: CLAAS Combine Display, Console, and Control Handle



## SETTING UP AUTO HEADER HEIGHT CONTROL

7. Use control knob (A) to highlight the icon that resembles a screwdriver (B).
8. Engage the combine separator and feeder house.
9. Press control knob (A) and a progress bar will appear.



Figure 7.159: CLAAS Combine Display, Console, and Control Handle

10. Fully raise the feeder house. Progress bar (A) will advance to 25%.
11. Fully lower the feeder house. Progress bar (A) will advance to 50%.
12. Fully raise the feeder house. Progress bar (A) will advance to 75%.
13. Fully lower the feeder house. Progress bar (A) will advance to 100%.



Figure 7.160: CLAAS Combine Display, Console, and Control Handle

14. Ensure progress bar (A) displays 100%. The calibration procedure is now complete.

**NOTE:**

If the voltage is not within the range of 0.5–4.5 V at any time throughout the calibration process, the monitor will indicate learning procedure not concluded.

**NOTE:**

If float was set heavier to complete ground calibration procedure, adjust to recommended operating float after the calibration is complete.



Figure 7.161: CLAAS Combine Display, Console, and Control Handle

## SETTING UP AUTO HEADER HEIGHT CONTROL

### Setting Cutting Height – CLAAS 600 and 700 Series

#### **WARNING**

Check to be sure all bystanders have cleared the area.

#### **NOTE:**

Changes may have been made to the combine controls or display since this document was published. Refer to the combine operator's manual for updates.

1. Lower the header to desired cutting height or ground pressure setting. The float indicator box should be set to 1.5.
2. Hold the left side of header raise and lower switch (A) until you hear a ping.

#### **NOTE:**

You can set two different cutting heights.



Figure 7.162: CLAAS Combine Display, Console, and Control Handle

### Setting the Sensitivity of the Auto Header Height Control – CLAAS 600 and 700 Series

The sensitivity adjustment controls the distance the cutterbar must travel up or down before the auto header height control (AHHC) reacts and raises or lowers the feeder house. When the sensitivity is set to maximum, only small changes in ground height are needed to cause the feeder house to raise or lower. When the sensitivity is set to minimum, large changes in the ground height are needed to cause the feeder house to raise or lower.

#### **NOTE:**

Changes may have been made to the combine controls or display since this document was published. Refer to the combine operator's manual for updates.

1. Use control knob (A) to highlight HEADER/REEL icon (B), and press control knob (A) to select it. The HEADER/REEL dialog box opens.
2. Select HEADER icon.

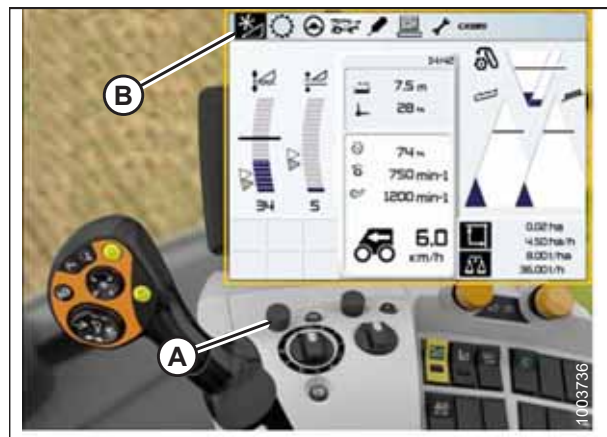

Figure 7.163: CLAAS Combine Display, Console, and Control Handle

## SETTING UP AUTO HEADER HEIGHT CONTROL

3. Select FRONT ATTACHMENT PARAMETER SETTINGS icon (A). A list of settings appears.
4. Select SENSITIVITY CAC (B) from the list.



Figure 7.164: CLAAS Combine Display, Console, and Control Handle

5. Select SENSITIVITY CAC icon (A).

**NOTE:**

To set the sensitivity, you will have to change CUTTING HEIGHT ADJUSTMENT (B) from the 0 default. The settings from 1–50 provide a faster response, whereas the settings from -1 to -50 provide a slower response. For best results, make adjustments in increments of 5.

6. If the reaction time between the header and the float module is too slow while cutting on the ground, increase the CUTTING HEIGHT ADJUSTMENT setting. If the reaction time between the header and the float module is too fast, decrease the CUTTING HEIGHT ADJUSTMENT setting.
7. If the header is lowered too slowly, increase the sensitivity. If the header hits the ground too hard or is lowered too quickly, decrease the sensitivity.



Figure 7.165: CLAAS Combine Display

### *Adjusting Auto Reel Speed – CLAAS 600 and 700 Series*

**NOTE:**

Changes may have been made to the combine controls or display since this document was published. Refer to the combine operator's manual for updates.

## SETTING UP AUTO HEADER HEIGHT CONTROL

1. Use control knob (A) to highlight HEADER/REEL icon (B), and press control knob (A) to select it. The HEADER/REEL dialog box opens.

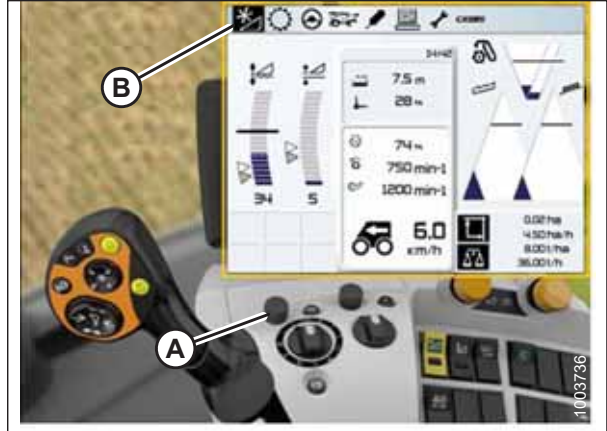

Figure 7.166: CLAAS Combine Display, Console, and Control Handle

2. Use control knob (A) to select REEL SPEED (B), and adjust the reel speed (if you are **NOT** using Auto Reel Speed). A graph displays in the dialog box.



Figure 7.167: CLAAS Combine Display, Console, and Control Handle

3. Select ACTUAL VALUE (A) from the AUTO REEL SPEED dialog box (if you are using Auto Reel Speed). The ACTUAL VALUE dialog box indicates the auto reel speed.



Figure 7.168: CLAAS Combine Display, Console, and Control Handle

## SETTING UP AUTO HEADER HEIGHT CONTROL

4. Use control knob (A) to raise or lower the reel speed.

**NOTE:**

This option is only available at full throttle.



Figure 7.169: CLAAS Combine Display, Console, and Control Handle

### Calibrating Reel Height Sensor – CLAAS 600 and 700 Series

**NOTE:**

Changes may have been made to the combine controls or display since this document was published. Refer to the combine operator's manual for updates.

To calibrate reel height, follow these steps:

1. Position the header until it is 15–25 cm (6–10 in.) off the ground.

**IMPORTANT:**

Do **NOT** turn off the engine. The combine has to be at full idle for the sensors to calibrate properly.

2. Use control knob (A) to highlight FRONT ATTACHMENT icon (B) and press control knob (A) to select it.



Figure 7.170: CLAAS Combine Display, Console, and Control Handle

## SETTING UP AUTO HEADER HEIGHT CONTROL

3. Use control knob (A) to highlight REEL icon (B), and press control knob (A) to select it.



Figure 7.171: CLAAS Combine Display and Console

4. Highlight REEL HEIGHT icon (A), and press control knob to select it.
5. Select LEARNING END STOPS (B) from the list.



Figure 7.172: CLAAS Combine Display and Console

6. Use control knob (A) to highlight screwdriver icon (B).



Figure 7.173: CLAAS Combine Display, Console, and Control Handle

## SETTING UP AUTO HEADER HEIGHT CONTROL

7. Press control knob and a progress bar chart (A) will appear.
8. Follow the prompts on the screen to raise the reel.
9. Follow the prompts on the screen to lower the reel.



Figure 7.174: CLAAS Combine Display, Console, and Control Handle

10. Ensure progress bar chart displays 100% (A). The calibration procedure is now complete.



Figure 7.175: CLAAS Combine Display, Console, and Control Handle

### *Adjusting Auto Reel Height – CLAAS 600 and 700 Series*

**NOTE:**

Changes may have been made to the combine controls or display since this document was published. Refer to the combine operator's manual for updates.

## SETTING UP AUTO HEADER HEIGHT CONTROL

To adjust the auto reel height, follow these steps:

1. Use HOTKEY rotary dial (A) to select REEL icon (B).

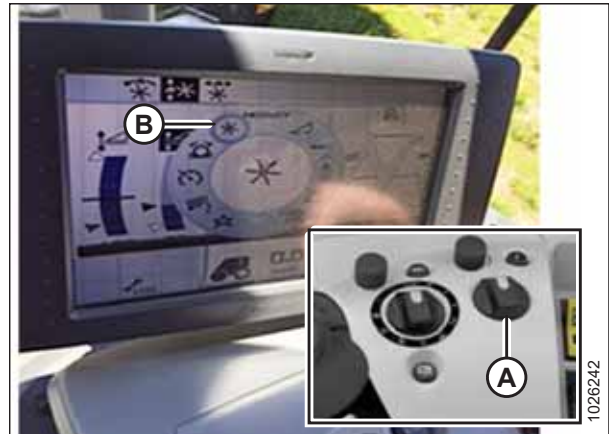

Figure 7.176: CLAAS Combine Display and Console

2. Use control knob (A) to select AUTO REEL HEIGHT icon (B) at the top of the page.

**NOTE:**

AUTO REEL HEIGHT icon (C) at the center of the page should be highlighted black. If it is not black, either the end stops have not been set or the AHHC is not active. For instructions, refer to *Calibrating Reel Height Sensor – CLAAS 600 and 700 Series*, page 257.

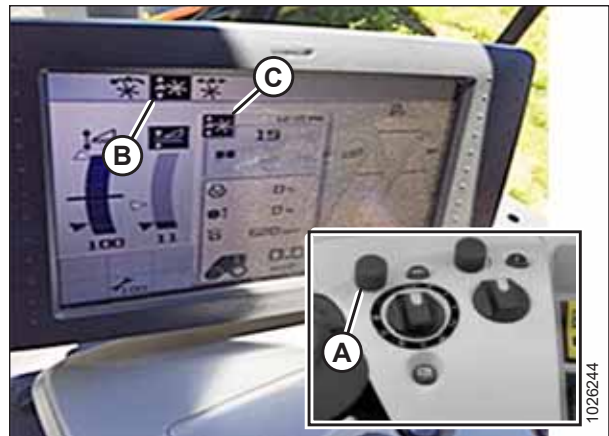

Figure 7.177: CLAAS Combine Display and Console

3. Adjust the auto reel height position for the current AHHC position using outer scroll knob (A). To lower the preset reel position, turn the scroll knob counterclockwise; to raise the preset reel position, turn the scroll knob clockwise. The display will update current setting (B).

**NOTE:**

If the AUTO REEL HEIGHT icon in the center of the page is not black, an AHHC position is not currently active.

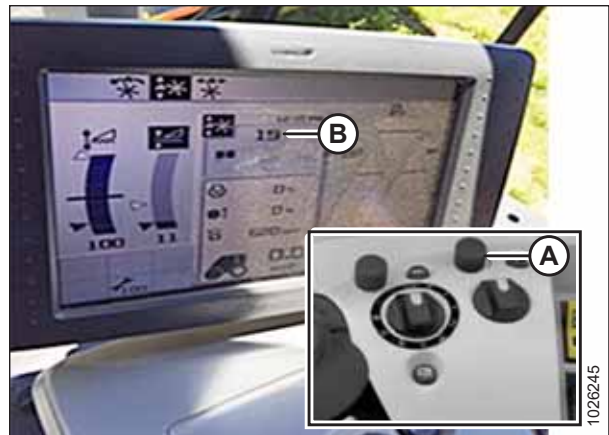

Figure 7.178: CLAAS Combine Display and Console

### 7.1.11 CLAAS 7000/8000 Series Combines

#### Setting up the Header – CLAAS 7000/8000 Series

Follow these steps to setup a MacDon header:



## SETTING UP AUTO HEADER HEIGHT CONTROL

### WARNING

Clear the area of other persons, pets etc. Keep children away from machinery. Walk around the machine to be sure no one is under, on, or close to it.

#### NOTE:

Changes may have been made to the combine controls or display since this document was published. Refer to the combine operator's manual for updates.

1. From the main page, select FRONT ATTACHMENT (A).



Figure 7.179: CEBIS Main Page

2. From the drop down list, select FRONT ATTACHMENT PARAMETERS (A).



Figure 7.180: Front Attachment Page

## SETTING UP AUTO HEADER HEIGHT CONTROL

3. From the Front Attachment Parameters page, select FRONT ATTACHMENT TYPE (A).
4. From the drop down list, select FLEX CUTTERBAR PRODUCT BY OTHER MANUFACTURER (B).



Figure 7.181: Attachment Parameters Page

5. From the Front Attachment Parameters page, select WORKING WIDTH (A).
6. Set header width by sliding adjuster arrow (B) up or down.
7. Select check mark (C) to save settings.

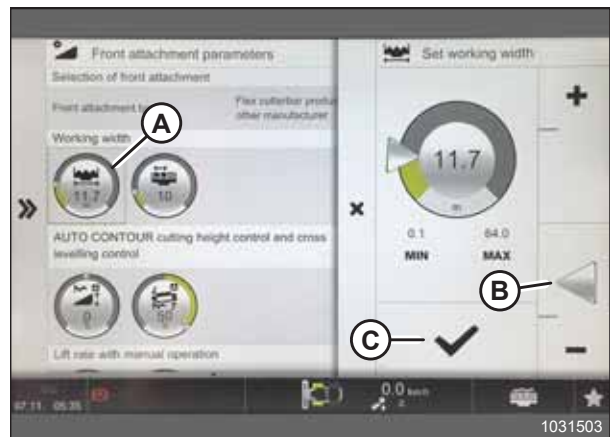

Figure 7.182: Attachment Parameters Page

### Setting up the Header Fore-Aft Tilt Function – CLAAS 7000/8000 Series

Follow these steps to setup the fore-aft tilt function on a MacDon header:

#### **WARNING**

Clear the area of other persons, pets etc. Keep children away from machinery. Walk around the machine to be sure no one is under, on, or close to it.

#### **NOTE:**

Changes may have been made to the combine controls or display since this document was published. Refer to the combine operator's manual for updates.

## SETTING UP AUTO HEADER HEIGHT CONTROL

1. From the main page, select FRONT ATTACHMENT (A).



Figure 7.183: CEBS Main Page

2. From the drop down list, select FRONT ATTACHMENT PARAMETERS (A).



Figure 7.184: Front Attachment Page

3. From the Front Attachment Parameters page, select FRONT ATTACHMENT TYPE (A).
4. From the drop down list, select FLEX CUTTERBAR PRODUCT BY OTHER MANUFACTURER (B).

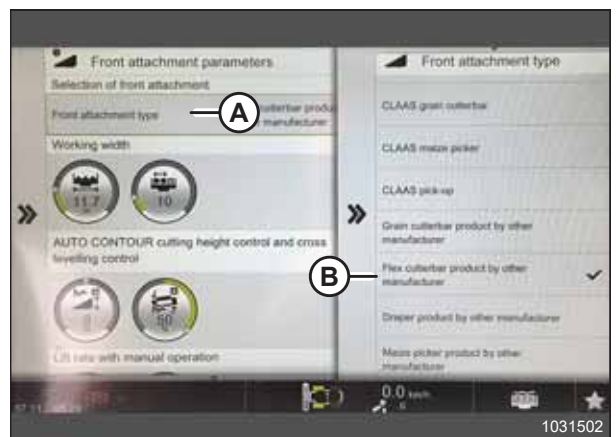

Figure 7.185: Attachment Parameters Page

## SETTING UP AUTO HEADER HEIGHT CONTROL

- From the main page, select SETTINGS (A).
- From the settings page, select FAVOURITE MANAGEMENT (B).



Figure 7.186: CEBIS Settings Page

- Add OTHER HEADER FUNCTIONS icon (A) as a favorite.

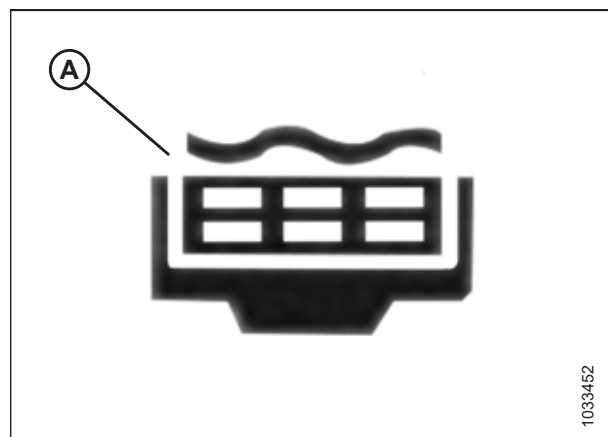

Figure 7.187: Other Header Functions Icon

- Select the OTHER HEADER FUNCTIONS icon so that it appears on the operator screen at location (A).
- You can now use the trigger (now shown) on the back of the handle to control the fore-aft and tilt of the header.

### NOTE:

The FAVOURITE MANAGEMENT menu on this monitor controls the trigger on the back of handle. The icon is showing at location (A) is the function controlled by the trigger.



Figure 7.188: CEBIS Main Page

## Calibrating the Auto Header Height Control – CLAAS 7000/8000 Series

### WARNING

Clear the area of other persons, pets etc. Keep children away from machinery. Walk around the machine to be sure no one is under, on, or close to it.

## SETTING UP AUTO HEADER HEIGHT CONTROL

### NOTE:

Changes may have been made to the combine controls or display since this document was published. Refer to the combine operator's manual for updates.

1. From the main page, select FRONT ATTACHMENT (A).



Figure 7.189: CEBIS Main Page

2. Select LEARNING PROCEDURES (A) from the menu.
3. SELECT FRONT ATTACHMENT HEIGHT (B).

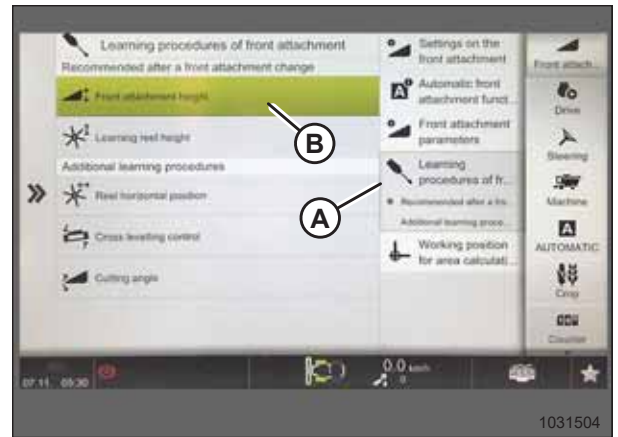

Figure 7.190: Learning Procedures Page

4. Follow the prompts that appear in Description and Notes fields (A).

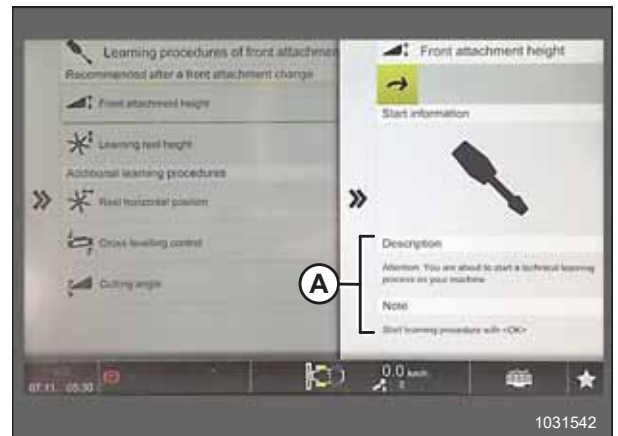

Figure 7.191: Front Attachment Height Page

## SETTING UP AUTO HEADER HEIGHT CONTROL

- When prompted, select OK button (A) to start the learning procedure.



Figure 7.192: Operator Controls

- When prompted, raise front attachment with button (A) on the multifunction lever.
- When prompted, lower front attachment with button (B) on multifunction lever.
- Repeat as prompted until calibration is complete.



Figure 7.193: Multifunction Lever

### Setting Cut and Reel Height Preset – CLAAS 7000/8000 Series

#### **WARNING**

Clear the area of other persons, pets etc. Keep children away from machinery. Walk around the machine to be sure no one is under, on, or close to it.

#### **NOTE:**

Changes may have been made to the combine controls or display since this document was published. Refer to the combine operator's manual for updates.

## SETTING UP AUTO HEADER HEIGHT CONTROL

1. Set desired cutting height with feederhouse raise/lower buttons (A) on the multifunction lever.
2. Set desired reel position with buttons (B).
3. Press and hold AUTO HEIGHT PRESET button (C) to store settings.



Figure 7.194: Multifunction Lever

A triangle (A) appears on the header height gauge indicating the preset level.



Figure 7.195: CEBIS Main Page

### *Setting the Sensitivity of the Auto Header Height Control – CLAAS 7000/8000 Series*

#### **WARNING**

Clear the area of other persons, pets etc. Keep children away from machinery. Walk around the machine to be sure no one is under, on, or close to it.

#### **NOTE:**

Changes may have been made to the combine controls or display since this document was published. Refer to the combine operator's manual for updates.

## SETTING UP AUTO HEADER HEIGHT CONTROL

1. From the main page, select FRONT ATTACHMENT (A).



Figure 7.196: CEBIS Main Page

2. From the drop down list, select FRONT ATTACHMENT PARAMETERS (A).



Figure 7.197: Front Attachment Parameters Page

3. Scroll through the list and select DROP RATE WITH AUTO CONTOUR icon (A).
4. Adjust the drop rate by sliding adjuster arrow (B) up or down.
5. Select check mark (C) to confirm settings.



Figure 7.198: Drop Rate with Auto Contour Page

### Adjusting Auto Reel Speed – CLAAS 7000/8000 Series

#### **WARNING**

Clear the area of other persons, pets etc. Keep children away from machinery. Walk around the machine to be sure no one is under, on, or close to it.



## SETTING UP AUTO HEADER HEIGHT CONTROL

### NOTE:

Changes may have been made to the combine controls or display since this document was published. Refer to the combine operator's manual for updates.

1. From the main page, select FRONT ATTACHMENT (A).



Figure 7.199: CEBIS Main Page

2. From the list, select SETTINGS ON FRONT ATTACHMENT (A).
3. Select REEL TARGET VALUES (B).
4. Select REEL SPEED ADJUST icon (C).



Figure 7.200: Settings on Front Attachment Page

5. Adjust the reel speed target value by sliding adjuster arrow (A) up or down.
6. Select check mark (B) to save setting.



Figure 7.201: Reel Speed Target Value Page



## SETTING UP AUTO HEADER HEIGHT CONTROL

5. Follow the prompts that appear in Description and Notes fields (A).

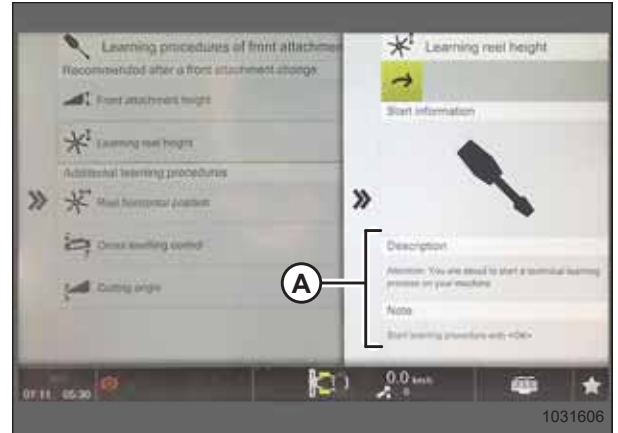

Figure 7.204: Learning Reel Height Page

6. When prompted, select OK button (A) to start the learning procedure.



Figure 7.205: Operator Controls

### 7.1.12 Gleaner R65/R66/R75/R76 and S Series Combines

#### Checking Voltage Range from the Combine Cab – Gleaner R65/R66/R75/R76 and Pre-2016 S Series

**NOTE:**

Changes may have been made to the combine controls or display since this document was published. Refer to the combine operator's manual for updates.

1. Position the header 150 mm (6 in.) above the ground, and unlock the float.

## SETTING UP AUTO HEADER HEIGHT CONTROL

2. Check that float lock linkage is on down stops (washer [A] cannot be moved) at both locations.

**NOTE:**

If the header is not on down stops during the next two steps, the voltage may go out of range during operation causing a malfunction of the auto header height control (AHHC) system.

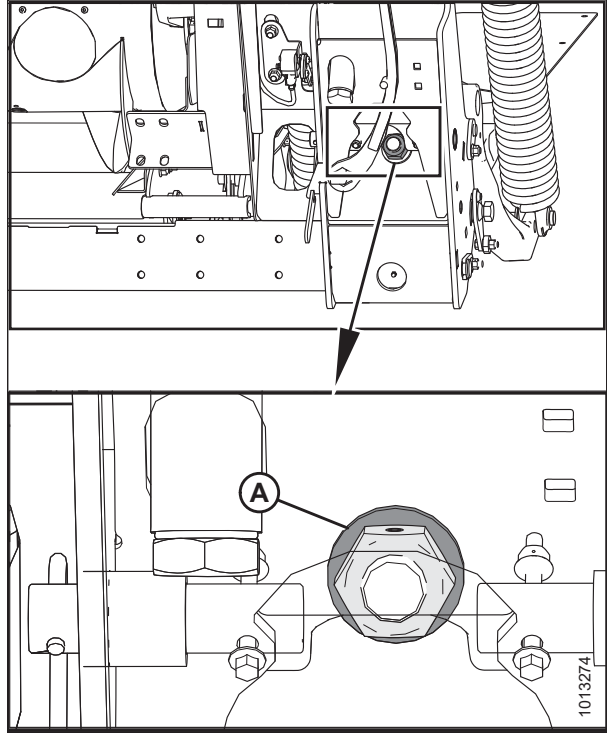

Figure 7.206: Float Lock

3. Ensure pointer (A) on the float indicator box is on 0. If necessary, adjust cable take-up bracket (B) until pointer is on 0.

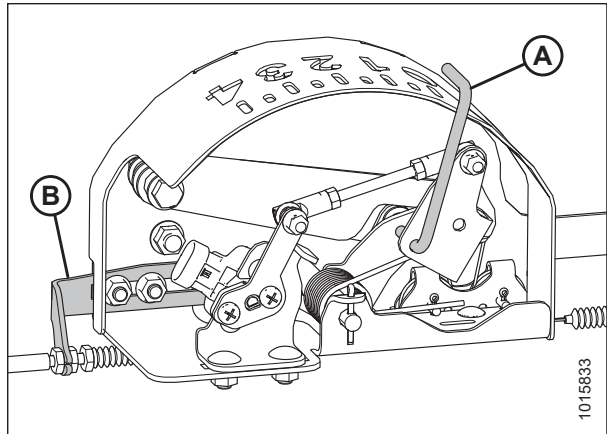

Figure 7.207: Float Indicator Box

## SETTING UP AUTO HEADER HEIGHT CONTROL



**Figure 7.208: Combine Heads-Up Display**

4. Ensure header float is unlocked.
5. Press and hold button (A) on the heads-up display for 3 seconds to enter diagnostic mode.
6. Scroll down using button (B) until LEFT is displayed on the LCD screen.
7. Press OK button (C). The number indicated on the LCD screen is the voltage reading from the sensor of the auto header height control (AHHC). Raise and lower the header to see the full range of voltage readings.

### *Engaging the Auto Header Height Control – Gleaner R65/R66/R75/R76 and Pre-2016 S Series*

**NOTE:**

Changes may have been made to the combine controls or display since this document was published. Refer to the combine operator's manual for updates.

The following system components are required in order for the auto header height control (AHHC) to work:

- Main module and header driver module mounted in card box in fuse panel (FP) module.
- Multifunction control handle operator inputs.
- Operator inputs mounted in the control console (CC) module panel.

**NOTE:**

In addition to the above components, the electrohydraulic header lift control valve is an integral part of the system.

## SETTING UP AUTO HEADER HEIGHT CONTROL



Figure 7.209: Combine Auto Header Height Controls

1. Press AUTO MODE button (A) until AHHC LED light (B) begins flashing. If the RTC light is flashing, press AUTO MODE button (A) again until it switches to AHHC.

### WARNING

Check to be sure all bystanders have cleared the area.

2. Briefly press button (A) on the control handle. The AHHC light should change from flashing to solid. The header also should drop toward the ground. The AHHC is now engaged and can be adjusted for height and sensitivity.
3. Use controls to adjust height and sensitivity to changing ground conditions such as shallow gullies and field drainage trenches.

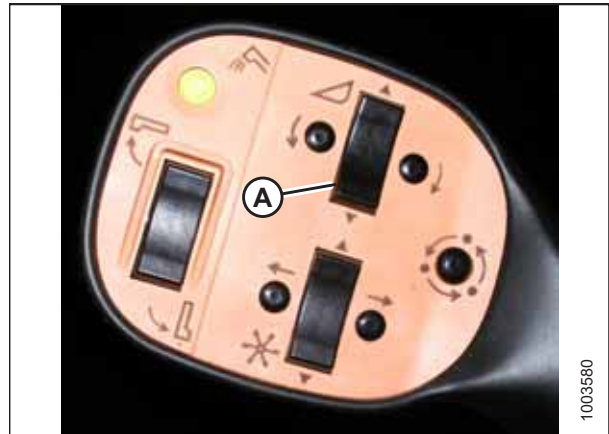

Figure 7.210: Control Handle

## SETTING UP AUTO HEADER HEIGHT CONTROL

### Calibrating the Auto Header Height Control – Gleaner R65/R66/R75/R76 and Pre-2016 S Series

Calibration should be done on flat, level ground without the header clutches engaged. Header height and header tilt must not be in auto or standby modes. The engine rpm must be above 2000 rpm. The header tilt option on 2004 and earlier model combines does not work with MacDon headers. This system will have to be removed and disabled in order to calibrate the auto header height control (AHHC). For instructions, refer to the combine operator's manual.

#### NOTE:

Changes may have been made to the combine controls or display since this document was published. Refer to the combine operator's manual for updates.

#### NOTE:

If header float is set too light, it can prevent calibration of AHHC. You may need to set the float heavier for calibration procedure so header doesn't separate from the float module.



Figure 7.211: Combine Auto Header Height Controls

A - AUTO MODE Button  
D - Raise Header  
G - CAL2 Button

B - AHHC Light  
E - Lower Header

C - CAL1 Button  
F - AUTO Mode

#### NOTE:

For best performance of the AHHC, perform these procedures with the center-link set to **D**. When setup and calibration are complete, adjust the center-link back to desired header angle. For instructions, refer to Header Angle in the header operator's manual for instructions.

1. Ensure center-link is set to **D**.
2. Press AUTO MODE button (A) until AHHC light (B) is illuminated.
3. Press and hold CAL1 button (C) until you see the following lights flash: raise header (D), lower header (E), tilt auto mode (F), and AHHC (B).
4. Fully lower the header, and continue to hold the HEADER LOWER button for 5–8 seconds to ensure float module has separated from header.

## SETTING UP AUTO HEADER HEIGHT CONTROL

5. Press CAL2 button (G) until lower header light (E) stops flashing, and release it when raise header light (D) begins flashing.
6. Raise header to its maximum height (ensure the header is resting on the down-stop pads).
7. Press CAL2 button (G) until raise header light (D) turns off.

### NOTE:

The following steps are applicable only to 2005 and newer combines with the Smartrac feeder house.

8. Wait for the HEADER TILT LEFT light (not shown) to start flashing, and then tilt header to the maximum left position.
9. Press CAL2 button (G) until the HEADER TILT LEFT light (not shown) stops flashing, and release button when the HEADER TILT RIGHT light (not shown) begins flashing.
10. Tilt the header to the maximum right position.
11. Press CAL2 button (G) until all of the following lights flash: raise header (D), lower header (E), height auto mode (A), right header and left header (not shown), and tilt auto mode (F).
12. Center the header.
13. Press CAL1 button (C) to exit calibration and save all values to the memory. All lights should stop flashing.

### NOTE:

If the float was set heavier to complete the AHHC calibration procedure, adjust to recommended operating float after the calibration is complete.

### *Turning off the Accumulator – Gleaner R65/R66/R75/R76 and Pre-2016 S Series*

The accumulator will affect the combine's reaction time and greatly inhibit the auto header height control's performance.

Refer to the combine operator's manual for proper procedure when turning accumulator off and on. For best performance, turn the feeder house accumulator off.

### NOTE:

The accumulator is located in front of the front left axle beam.



**Figure 7.212: Combine Accumulator ON/OFF Switch**

A - Accumulator Lever (Off Position)



## SETTING UP AUTO HEADER HEIGHT CONTROL

### *Adjusting the Header Raise/Lower Rate – Gleaner R65/R66/R75/R76 and Pre-2016 S Series*

**NOTE:**

Changes may have been made to the combine controls or display since this document was published. Refer to the combine operator's manual for updates.

The auto header height control (AHHC) system's stability is affected by hydraulic flow rates. Ensure that header raise (A) and header lower (B) adjustable restrictors in the hydraulic manifold are adjusted so that it takes approximately 6 seconds to raise the header from ground level to maximum height (hydraulic cylinders fully extended), and approximately 6 seconds to lower the header from maximum height to ground level.

If there is too much header movement (for example, hunting) when the header is on the ground, adjust the lower rate to a slower rate of drop: 7 or 8 seconds.

**NOTE:**

Make this adjustment with the hydraulic system at normal operating temperature (54.4°C [130°F]) and the engine running at full throttle.

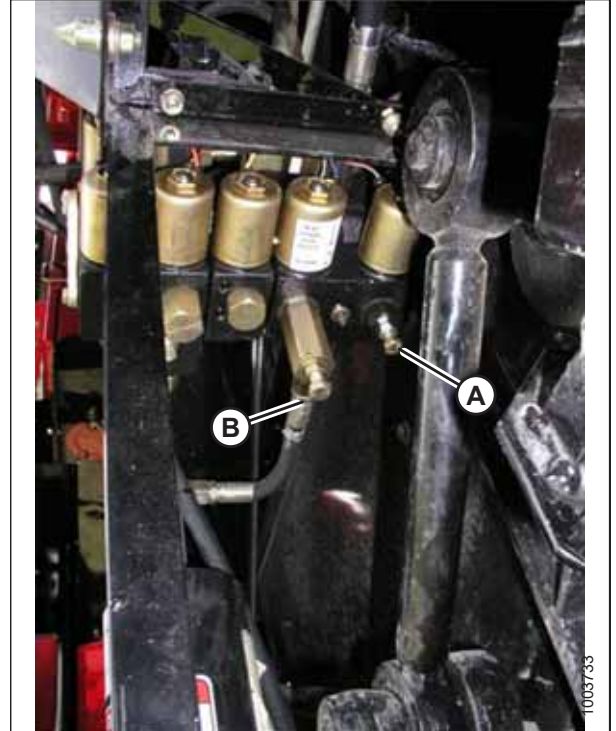

Figure 7.213: Header Raise and Lower Adjustable Restrictors

### *Adjusting Ground Pressure – Gleaner R65/R66/R75/R76 and Pre-2016 S Series*

**NOTE:**

Changes may have been made to the combine controls or display since this document was published. Refer to the combine operator's manual for updates.

1. Ensure indicator (A) is at position 0 (B) with the header 254–306 mm (10–14 in.) off the ground. If not, the float sensor output voltage should be checked. For instructions, refer to [Checking Voltage Range from the Combine Cab – Gleaner R65/R66/R75/R76 and Pre-2016 S Series, page 271](#).

**NOTE:**

When the header is on the ground, the indicator should be at position 1 (C) for low ground pressure, and at position 4 (D) for high ground pressure. Crop and soil conditions determine the amount of float to use. The ideal setting is as light as possible without header bouncing or missing crop. Operating with heavy settings prematurely wears the cutterbar wearplates.

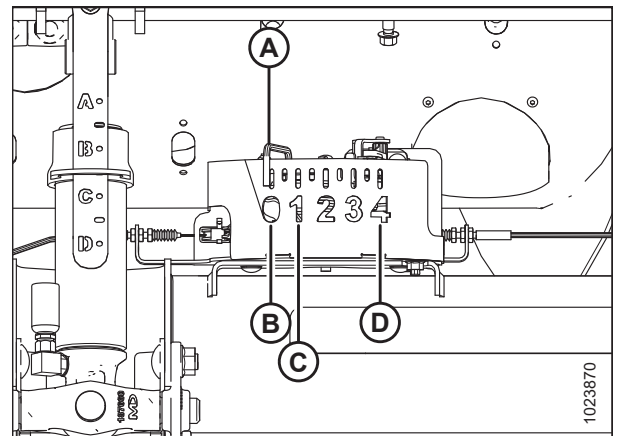

Figure 7.214: Float Indicator Box

## SETTING UP AUTO HEADER HEIGHT CONTROL

2. Ensure the header is in auto header height control (AHHC) mode. This is indicated by AUTO MODE LED light (A) displaying a continuous, solid light.
3. The header will lower to the height (ground pressure) corresponding to the position selected with height control knob (B). Turn the knob counterclockwise for minimum ground pressure, and clockwise for maximum ground pressure.



Figure 7.215: AHHC Console

### *Adjusting the Sensitivity of the Auto Header Height Control – Gleaner R65/R66/R75/R76 and Pre-2016 S Series*

**NOTE:**

Changes may have been made to the combine controls or display since this document was published. Refer to the combine operator's manual for updates.



Figure 7.216: Auto Header Height Control Console

SENSITIVITY ADJUSTMENT dial (A) controls the distance the cutterbar must travel up or down before the auto header height control (AHHC) reacts and raises or lowers the feeder house.

When SENSITIVITY ADJUSTMENT dial (A) is set to maximum (turned completely clockwise), only small changes in ground height are needed to cause the feeder house to raise or lower. In this position, the cutterbar moves up and down approximately 19 mm (3/4 in.) before the control module signals the hydraulic control valve to raise or lower the header frame.

## SETTING UP AUTO HEADER HEIGHT CONTROL

When SENSITIVITY ADJUSTMENT dial (A) is set to minimum (turned completely counterclockwise), large changes in ground height are needed to cause the feeder house to raise or lower. In this position, the cutterbar moves up and down approximately 51 mm (2 in.) before the control module signals the hydraulic control valve to raise or lower the header frame.

The HEADER SENSE LINE input also changes the range of the sensitivity. When connected to a draper, the counterclockwise position (least sensitive) allows for approximately 102 mm (4 in.) of vertical travel before correction is made.

### *Troubleshooting Alarms and Diagnostic Faults – Gleaner R65/R66/R75/R76 and Pre-2016 S Series*

#### **NOTE:**

Changes may have been made to the combine controls or display since this document was published. Refer to the combine operator's manual for updates.

#### **Display type:**

Displayed on tachometer (A) as XX or XXX.



**Figure 7.217: Tachometer**

## SETTING UP AUTO HEADER HEIGHT CONTROL

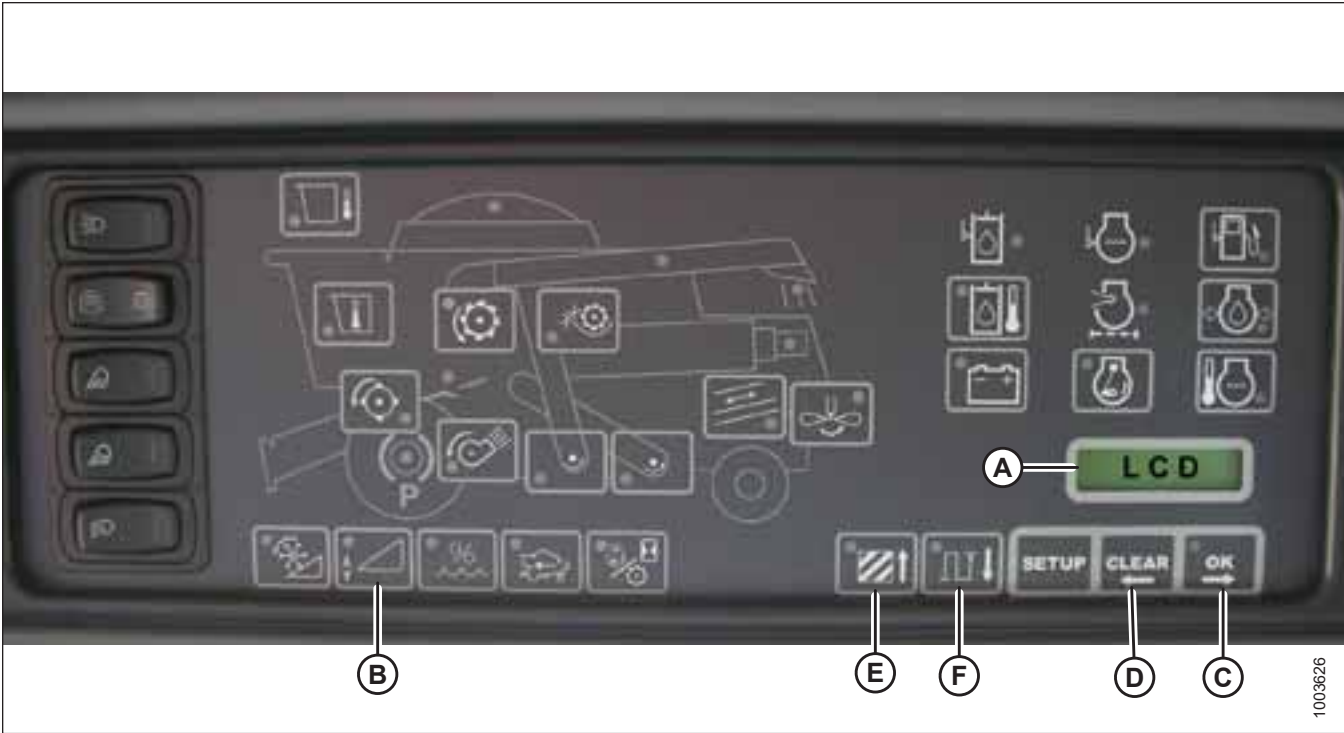

Figure 7.218: Combine Electronic Instrument Panel (EIP)

### NOTE:

Displayed on LCD (A) as XX in. or XXX cm.

### Alarm conditions:

If an error message is received from the fuse panel, an audible alarm sounds. The alarm buzzer sounds five times every 10 seconds. The LCD (A) on the electronic instrument panel (EIP) indicates the header system in error as HDR CTRL followed by HGT ERR for height, and HDR CTRL followed by TILT ERR for tilt. The header height LED flashes yellow two times every second.

When an alarm condition occurs, a green LED flashes on and off (green, yellow, or red depending on the input). In addition, a message is displayed on the LCD to identify the nature of the alarm. For example, HYD TEMP, OPEN, SHRT will be flashed alternately.

### Diagnostic fault failures:

Refer to Figure 7.218, page 280.

Pressing header height switch (B) for a minimum of 5 seconds will put the EIP in header diagnostic mode. The LCD (shown on previous screen) will display the message HDR DIAG when the EIP has entered header diagnostic mode.

In this mode, after 3 seconds, header fault parameter labels are displayed on the EIP LCD. All the information displayed is read-only.

OK (C) and CLEAR (D) buttons allow you to scroll through the list of parameters. If there are no active fault codes, the EIP LCD will display NO CODE.

When a parameter is displayed, its label is displayed for 3 seconds, after which its value is automatically displayed.

Pressing OK button (C) while the value is displayed will advance to the next parameter and display its label.

When a parameter label is displayed and OK button (C) is pressed before 3 seconds, the parameter's value will be displayed.

## SETTING UP AUTO HEADER HEIGHT CONTROL

Pressing AREA (E) will cycle through the options. When LEFT is displayed on the LCD, press OK button (C), and the auto header height control (AHHC) voltage will be shown on the display.

Press DIST button (F) to cycle back through the table.

Press CLEAR button (D) to exit header diagnostics and return to normal mode.

### 7.1.13 Gleaner S9 Series Combines

#### Setting up the Header – Gleaner S9 Series

**NOTE:**

Changes may have been made to the combine controls or display since this document was published. Refer to the combine operator's manual for updates.

AGCO Tyton terminal (A) is used to set up and manage a MacDon draper header on a Gleaner S9 Series combine. Use the touch screen display to select the desired item on the screen.



Figure 7.219: Gleaner S9

A - Tyton Terminal      B - Control Handle  
C - Throttle            D - Header Control Cluster

1. On the top right quadrant of the home screen, touch COMBINE icon (A). The COMBINE MAIN MENU opens.



Figure 7.220: Combine Icon on Home Page



## SETTING UP AUTO HEADER HEIGHT CONTROL

3. Touch **HEADER CONFIGURATION** field (A). A dialog box showing predefined headers opens.
  - If your MacDon header is already set up, it appears on the header list. Touch MacDon header title (B) to highlight the selection in blue, and then touch green check mark (E) to continue.
  - If only default header (D) is shown, touch ABC button (C), and use the on-screen keyboard to enter the MacDon header information. When complete, select one of the following options to return to the **HEADER SETTINGS** page:
    - Green check mark (E) saves the settings
    - Garbage can icon (F) deletes the highlighted header from the list
    - Red X (G) cancels the change(s)

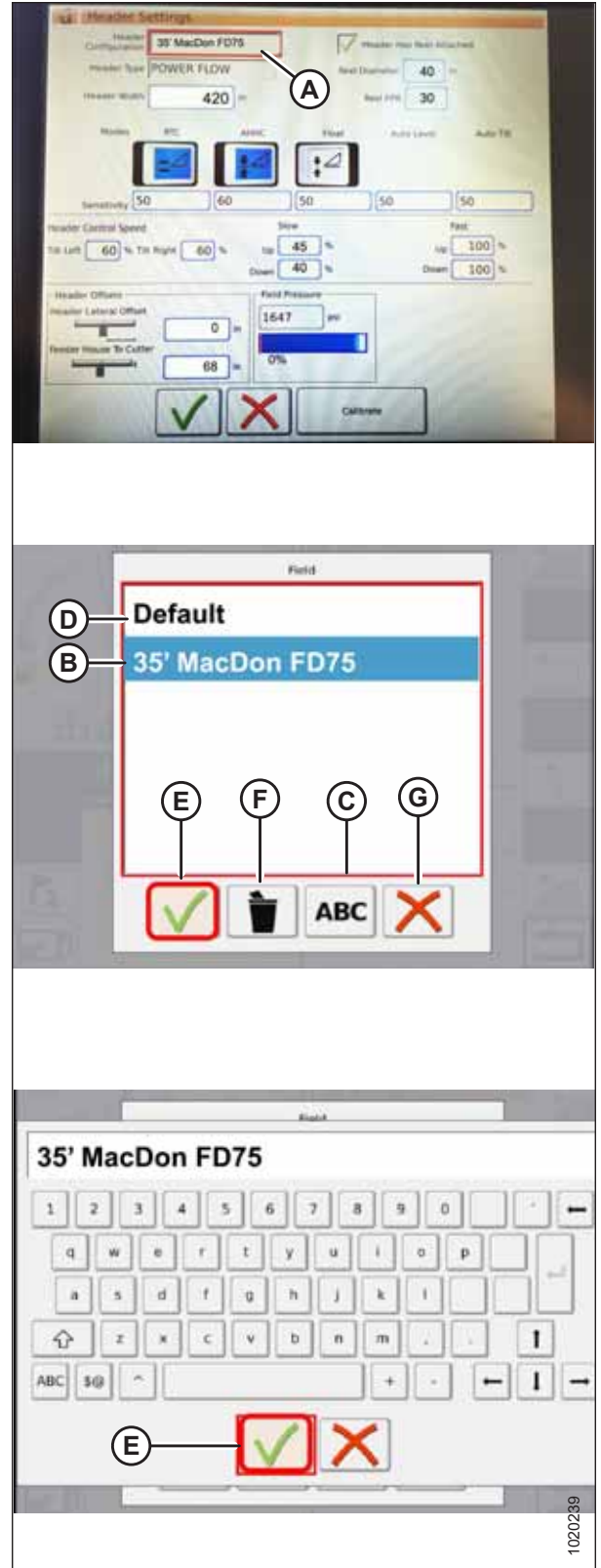

Figure 7.222: Header Configuration Menu on Header Settings Page

## SETTING UP AUTO HEADER HEIGHT CONTROL

- To specify the type of header installed on the machine, touch HEADER TYPE field (A).

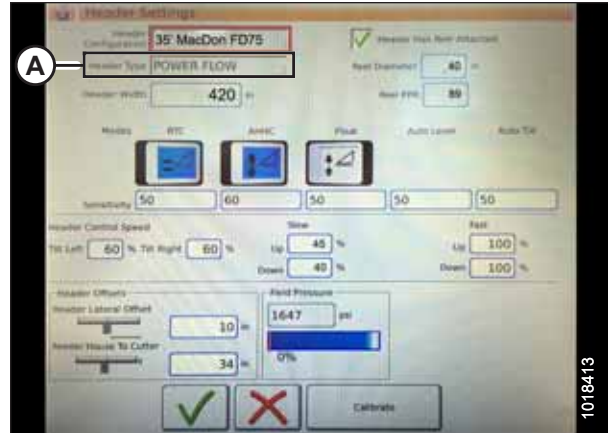

Figure 7.223: Header Settings

- A list of predefined header types appears.
  - For MacDon D1 Series Draper and FD1 Series FlexDraper® headers, touch POWER FLOW (A)
  - Touch green check mark (B) to save the selection and continue

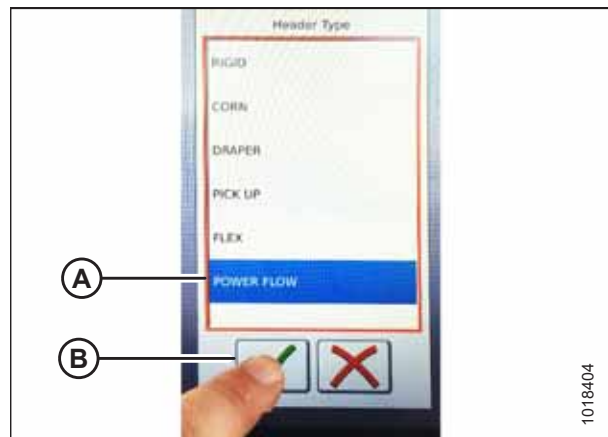

Figure 7.224: Header Type

- Make sure that HEADER HAS REEL ATTACHED check box (A) is checked.

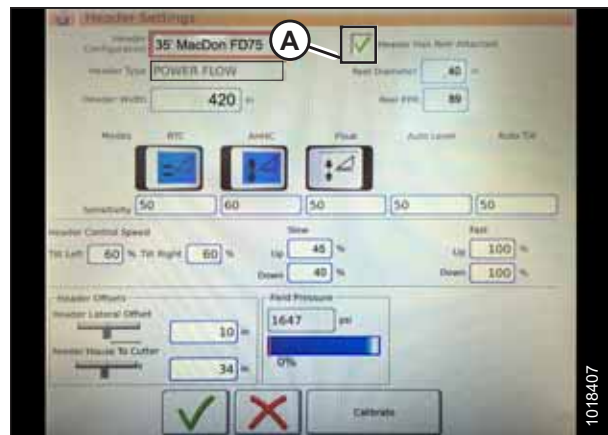

Figure 7.225: Header Settings



## SETTING UP AUTO HEADER HEIGHT CONTROL

7. Touch REEL DIAMETER field (A) and a numeric keypad displays. Enter **40** for a MacDon reel.
8. Touch REEL PPR (Pulses Per Revolution) field (B) and enter **30** as the value for your MacDon header.

### NOTE:

PPR is determined by the number of teeth on the reel speed sprocket.

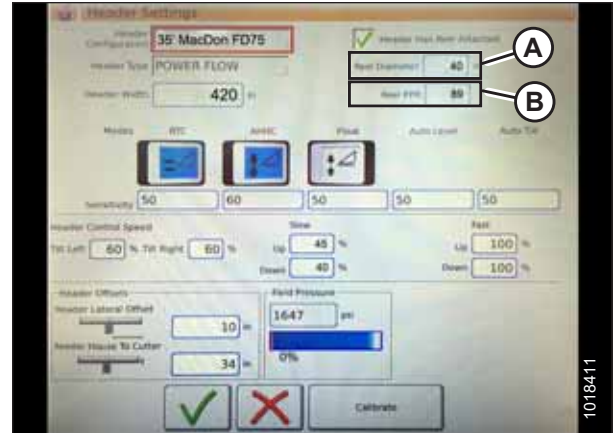

Figure 7.226: Header Settings

9. Touch green check mark (B) at the bottom of numeric keypad when complete, or the red X to cancel.

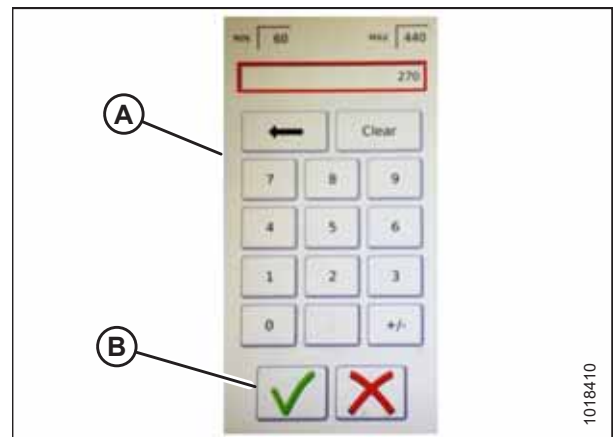

Figure 7.227: Numeric Keypad

10. When complete, touch green check mark (A) at the bottom of the HEADER SETTINGS page.

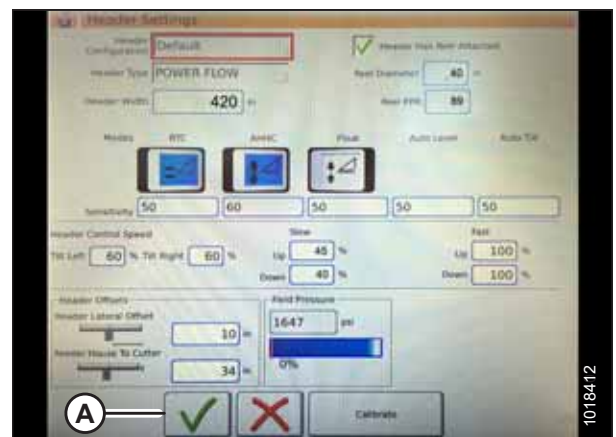

Figure 7.228: Header Settings Page

## SETTING UP AUTO HEADER HEIGHT CONTROL

### Setting Minimum Reel Speed and Calibrating Reel – Gleaner S9 Series

#### **WARNING**

Clear the area of other persons, pets etc. Keep children away from machinery. Walk around the machine to be sure no one is under, on, or close to it.

#### **NOTE:**

Changes may have been made to the combine controls or display since this document was published. Refer to the combine operator's manual for updates.

1. From the COMBINE MAIN MENU, touch REEL SETTINGS (A) to open the REEL SETTINGS page.



Figure 7.229: Reel Settings on Combine Main Menu

2. To set minimum reel speed, touch SPEED MINIMUM FIELD (B). The on-screen keyboard displays. Enter the desired value. Touch the green check mark to accept the new value, or the red X to cancel. The reel speed is shown in mph and rpm.

#### **NOTE:**

At the bottom of the REEL SETTINGS page, the reel diameter and reel pulses per revolution (PPR) are displayed. These values have already been set in the HEADER SETTINGS page.

3. Reel speed is calibrated on the REEL SETTINGS page by touching CALIBRATE button (A) in the top right of the page.

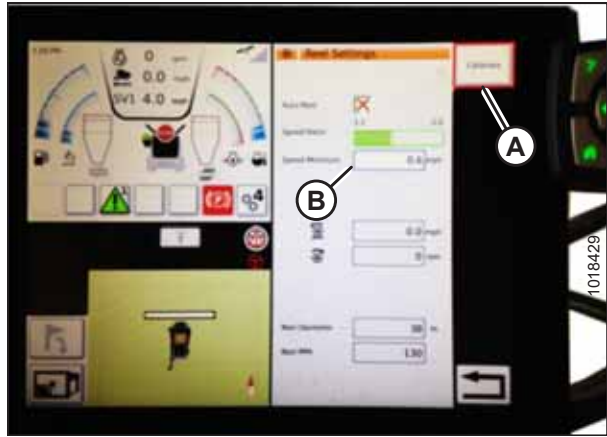

Figure 7.230: Reel Settings Calibration

## SETTING UP AUTO HEADER HEIGHT CONTROL

The CALIBRATION WIZARD opens and displays a hazard warning.



Figure 7.231: Calibration Wizard

4. Make sure to meet all the conditions listed in the CALIBRATION WIZARD warning. Press green check mark (A) to accept and start reel calibration. Pressing red X (B) will cancel the calibration procedure.



Figure 7.232: Calibration Wizard

5. A message appears in the CALIBRATION WIZARD stating that reel calibration has started. The reel will begin turning slowly and increase to high speed. A progress bar is provided. If necessary, touch the red X to cancel. Otherwise, wait for the message that reel calibration has completed successfully. Touch the green check mark to save the calibrated settings.

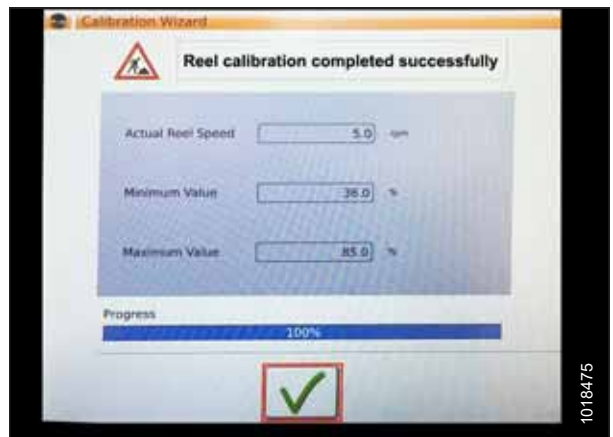

Figure 7.233: Calibration Progress

## SETTING UP AUTO HEADER HEIGHT CONTROL

### Setting up Automatic Header Controls – Gleaner S9 Series

Automatic header functions are configured on the HEADER SETTINGS page.

#### NOTE:

Changes may have been made to the combine controls or display since this document was published. Refer to the combine operator's manual for updates.

1. **Automatic Control Functions:** There are toggle (OFF/ON) switches on the HEADER SETTINGS page for the automatic control functions. For MacDon headers, ensure the following two functions are enabled as shown:
  - RTC (return to cut) (A)
  - AHHC (automatic header height control) (B)

- RTC (return to cut) (A)
- AHHC (automatic header height control) (B)

All other switches are disabled (not highlighted).

2. **Sensitivity** setting (C) controls how responsive a control (RTC or AHHC) is to a given change in sensor feedback. The setting fields are located directly below the toggle switches. To enter a new sensitivity setting, touch the setting field below the specific toggle switch, and enter the new value in the on-screen keyboard.

- Increase sensitivity if the combine does not change the feeder position quickly enough when in Auto Mode.
- Decrease sensitivity if the combine hunts for a position in Auto Mode.

#### NOTE:

Recommended sensitivity starting points for MacDon headers are:

- 50 for RTC (A)
- 60 for AHHC (B)

3. **Header Speed:** HEADER CONTROL SPEED area (A) on the HEADER SETTINGS page is used to adjust the following speeds:

- Tilt left and right is the lateral tilt of the combine faceplate
- Header up and down (slow and fast speeds) is a two-stage button with slow speed on the first detent and fast on the second

#### NOTE:

Recommended header control speed starting points

- Slow: 45 up / 40 down
- Fast: 100 up / 100 down

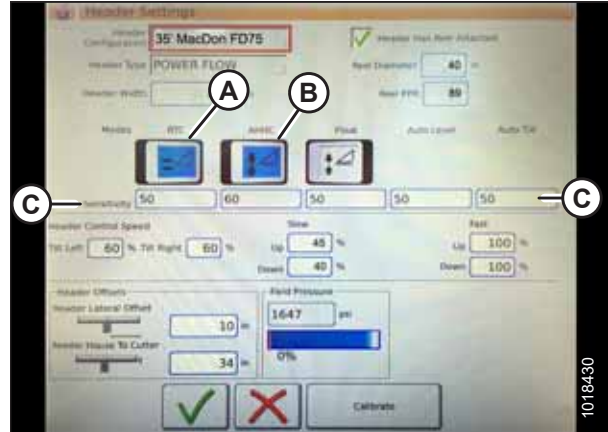

Figure 7.234: Automatic Controls and Sensitivity Settings

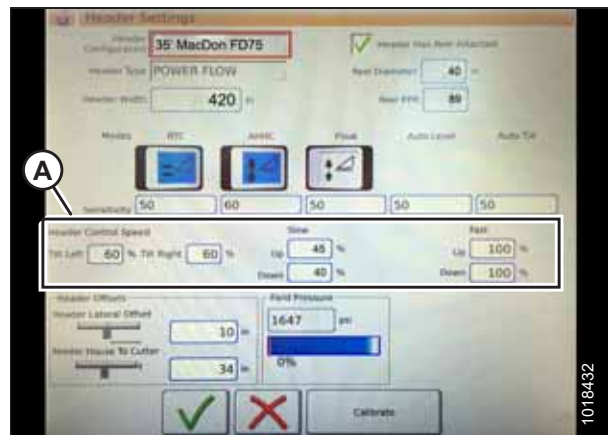

Figure 7.235: Header Speed Control Settings

## SETTING UP AUTO HEADER HEIGHT CONTROL

4. **Header Offsets (A):** Offset distances are important for yield mapping. There are two adjustable dimensions on the HEADER SETTINGS page:

- Header Lateral Offset: the distance between the centerline of the header and the centerline of the machine. Set to **0** for a MacDon header.
- Feeder House to Cutter: the distance from the machine interface to the cutterbar. Set to **68** for a MacDon header.

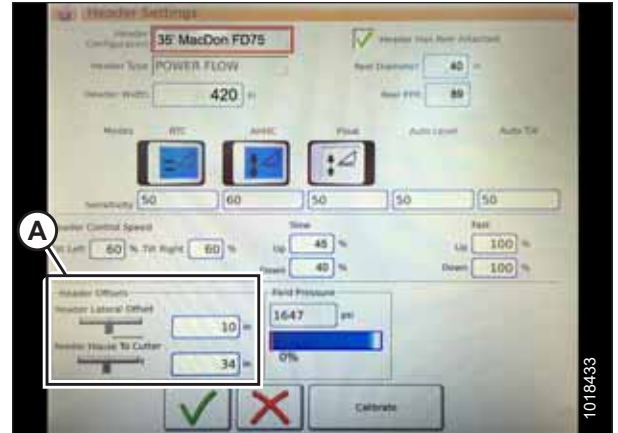

Figure 7.236: Header Offset Settings

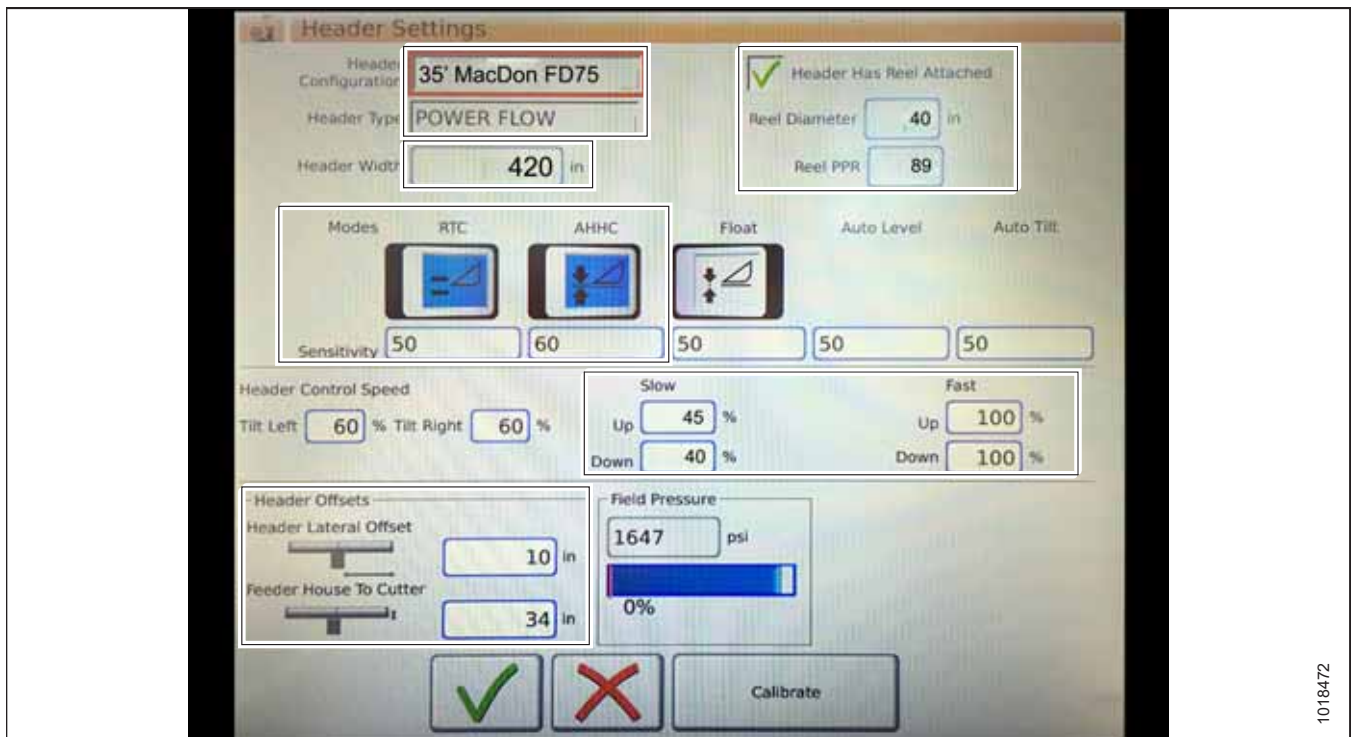

Figure 7.237: MacDon Header Settings Inputs

## SETTING UP AUTO HEADER HEIGHT CONTROL

### Calibrating the Header – Gleaner S9 Series

The auto header control functions are configured on the HEADER SETTINGS page.

#### **WARNING**

Clear the area of other persons, pets etc. Keep children away from machinery. Walk around the machine to be sure no one is under, on, or close to it.

#### **NOTE:**

Changes may have been made to the combine controls or display since this document was published. Refer to the combine operator's manual for updates.

1. On the COMBINE MAIN MENU, touch HEADER SETTINGS (A).



Figure 7.238: Combine Main Menu

2. Touch CALIBRATE (A) at the bottom right of the page. The HEADER CALIBRATION page displays.

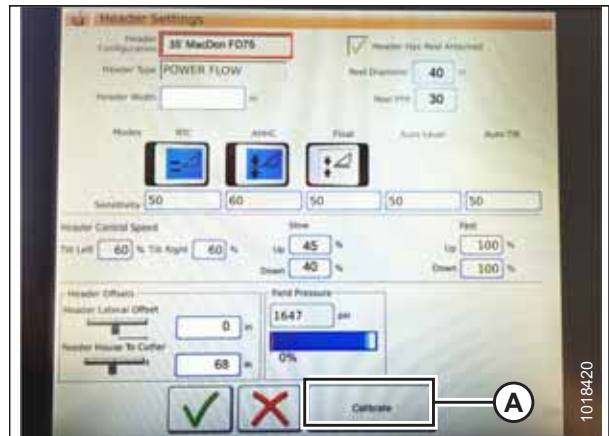

Figure 7.239: Header Settings Page

## SETTING UP AUTO HEADER HEIGHT CONTROL

The right side of the page shows Header Calibration information (A). Results are shown for a variety of sensors (B):

- Left and right header sensor (voltage) (values will be the same with MacDon headers)
- Header height sensor (mA)
- Tilt position sensor (mA)

The following valid modes are shown with check marks (C) below sensor values (B):

- Return to cut
- Automatic header height control

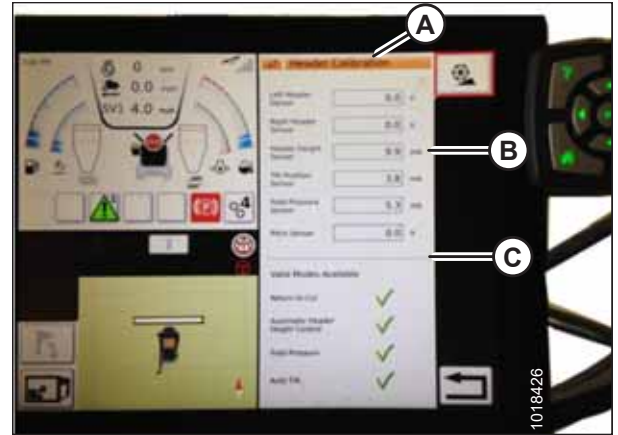

Figure 7.240: Header Calibration Page

### WARNING

Clear the area of other persons, pets etc. Keep children away from machinery. Walk around the machine to be sure no one is under, on, or close to it.

3. On the control handle, touch HEADER DOWN button (A). Sensor values start changing on the HEADER CALIBRATION page as the header lowers.

#### NOTE:

The header needs to be lowered all the way, and then raised off the ground. The range should be between **0.5 and 4.5 V**. If the value is not in that range, the sensor needs to be adjusted. For instructions, refer to [Adjusting Voltage Limits – One-Sensor System, page 194](#) or [Adjusting Voltage Limits – Two-Sensor System, page 195](#).



Figure 7.241: Header Down Switch

4. When the sensor values are stable, touch CALIBRATE icon (A).



Figure 7.242: Header Calibration

## SETTING UP AUTO HEADER HEIGHT CONTROL

5. The hazard warning for HEADER CALIBRATION appears. Make sure that all conditions are met.
6. Touch the green check mark at the bottom of the page to start the CALIBRATION WIZARD.



Figure 7.243: Header Calibration Warning

A progress bar is provided and the calibration can be stopped at any time by touching the red X. The header moves automatically and erratically during this process.

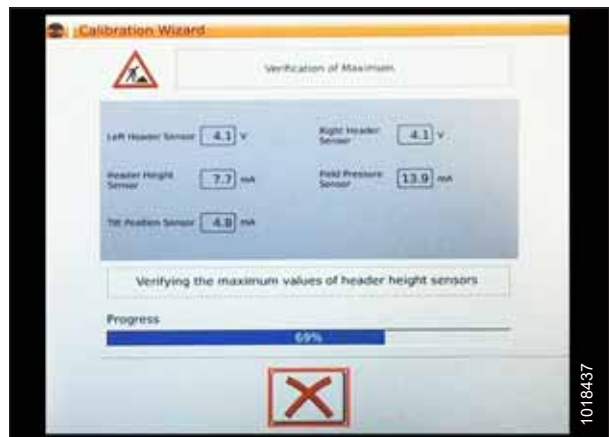

Figure 7.244: Calibration in Progress

7. When the calibration is complete, a message displays, and summary information (A) is shown. Green check marks confirm the functions have been calibrated (B). Touch bottom green check mark (C) to save.



Figure 7.245: Completed Calibration Page



## SETTING UP AUTO HEADER HEIGHT CONTROL

### NOTE:

Touch CALIBRATION icon (A) on the COMBINE MAIN MENU page to display the CALIBRATION MENU where you can choose from a variety of calibrations including header and reel calibration.



Figure 7.246: Direct Calibration Menu

### Operating the Auto Header Height Control – Gleaner S9 Series

#### NOTE:

Changes may have been made to the combine controls or display since this document was published. Refer to the combine operator's manual for updates.

The following controls are used to operate the auto header height control (AHC) functions:

- Tyton terminal (A)
- Control handle (B)
- Throttle (C)
- Header control cluster (D)

Use the combine operator's manual to familiarize yourself with the controls.



Figure 7.247: Gleaner S9 Operator Controls

1. With the header running, set lateral tilt switch (A) to MANUAL.
2. Engage the AHC by pressing switch (B) upward to the I position.



Figure 7.248: Header Control Cluster

## SETTING UP AUTO HEADER HEIGHT CONTROL

3. Press AHHC control switch (A) on the control handle to engage the AHHC. The header moves to the current setpoint position.



Figure 7.249: AHHC on Control Handle

4. Use HEADER HEIGHT SETPOINT control dial (A) as necessary to fine-tune the position.



Figure 7.250: Header Control Cluster

### Reviewing Header In-Field Settings – Gleaner S9 Series

#### NOTE:

Changes may have been made to the combine controls or display since this document was published. Refer to the combine operator's manual for updates.

1. To view header group settings, touch HEADER icon (A) on the right side of the home page.

The following information is displayed:

- CURRENT POSITION of header (B).
- SETPOINT cut-off position (C) (indicated by red line)
- HEADER symbol (D) – touch to adjust the setpoint cut-off position using the scroll wheel on the right side of the Tyton terminal.
- CUT HEIGHT for AHHC (E) – fine-tune with the header height setpoint control dial on the header control cluster.
- HEADER WORKING WIDTH (F)
- HEADER PITCH (G)

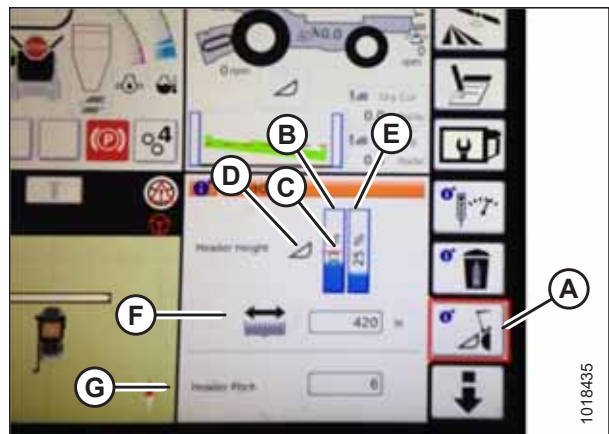

Figure 7.251: Header Groups

## SETTING UP AUTO HEADER HEIGHT CONTROL

2. Touching a field opens the on-screen keyboard so that values can be adjusted. Enter the new value and touch the green check mark when complete.

**NOTE:**

Scroll wheel (A) is located on the right side of the Tyton terminal.



Figure 7.252: Adjustment Wheel on Right Side of Tyton Terminal

**NOTE:**

HEADER HEIGHT SETPOINT control dial (A) is on the header control cluster.



Figure 7.253: Header Control Cluster

### 7.1.14 John Deere 60 Series Combines

#### *Checking Voltage Range from the Combine Cab – John Deere 60 Series*

**NOTE:**

Changes may have been made to the combine controls or display since this document was published. Refer to the combine operator's manual for updates.



#### **WARNING**

Check to be sure all bystanders have cleared the area.

1. Position the header 150 mm (6 in.) above the ground, and unlock the float.

## SETTING UP AUTO HEADER HEIGHT CONTROL

2. Check that float lock linkage is on down stops (washer [A] cannot be moved) at both locations.

**NOTE:**

If the header is not on down stops during the next two steps, the voltage may go out of range during operation causing a malfunction of the AHHC system.

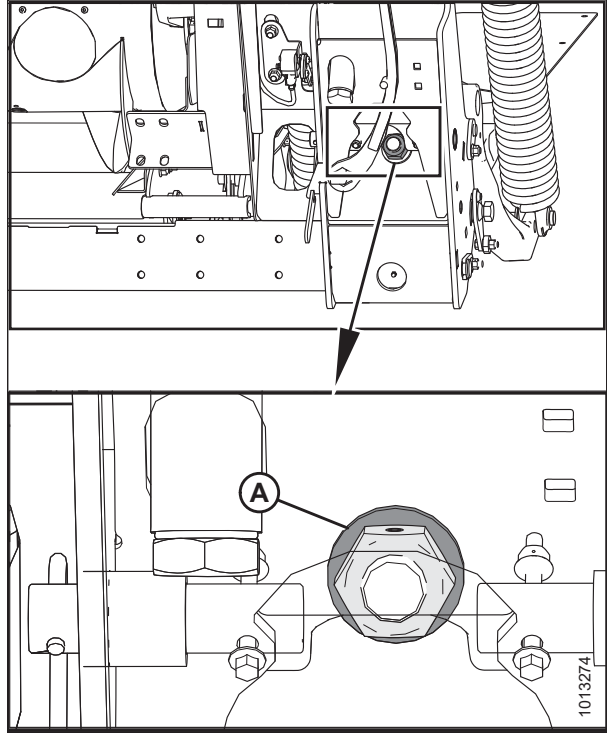

Figure 7.254: Float Lock

3. Adjust cable take-up bracket (B) (if necessary) until float indicator pointer (A) is on 0.

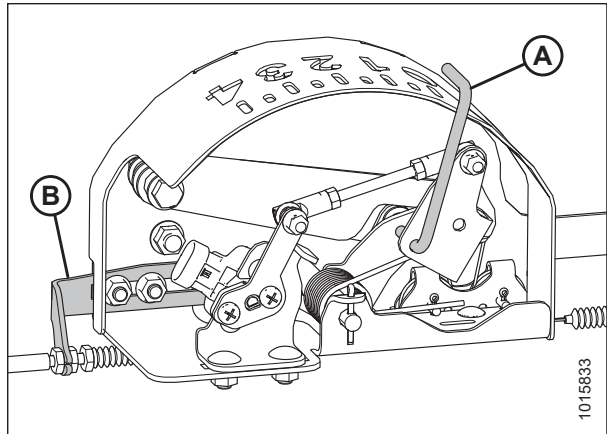
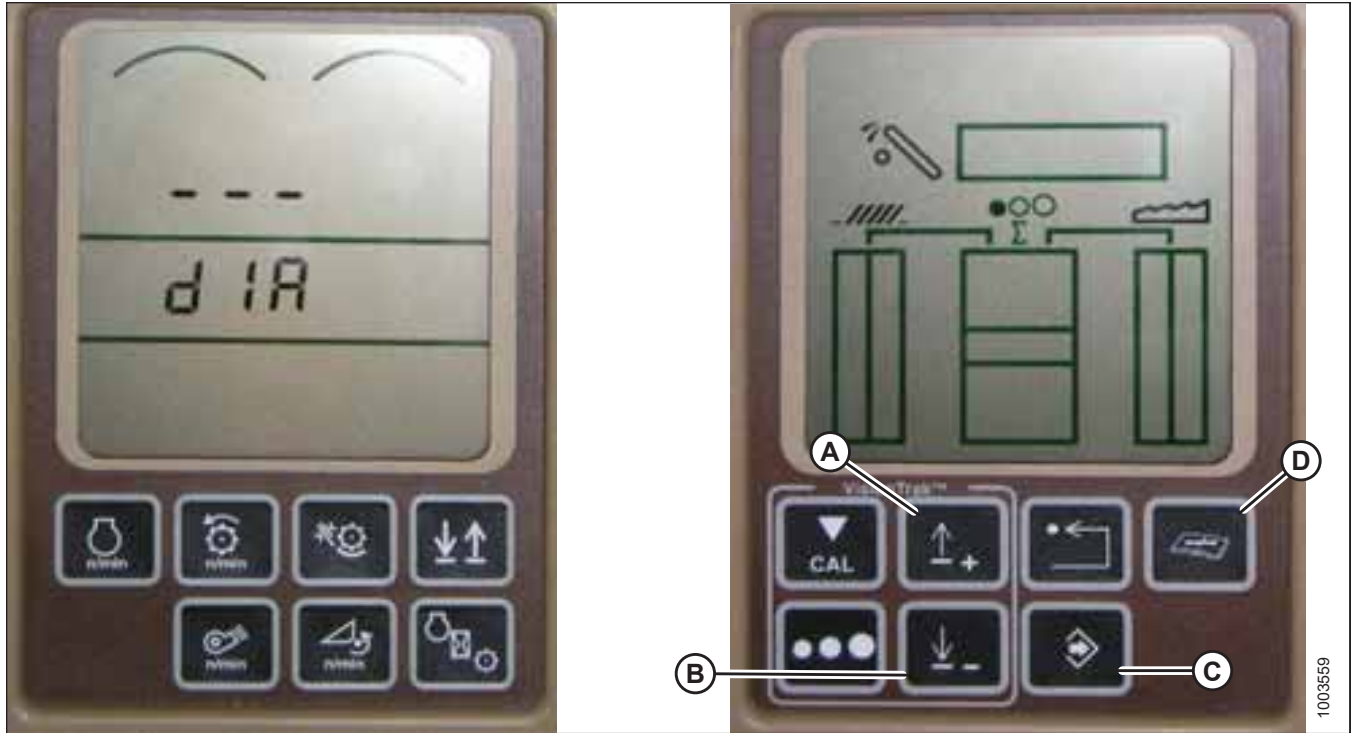

Figure 7.255: Float Indicator Box

## SETTING UP AUTO HEADER HEIGHT CONTROL



**Figure 7.256: John Deere Combine Display**

4. Press DIAGNOSTIC button (D) on the monitor—DIA appears on the monitor.
5. Press UP button (A) until EO1 appears on the monitor—this is the header adjustments.
6. Press ENTER button (C).
7. Press the UP (A) or DOWN button (B) until 24 is displayed on the top portion of the monitor—this is the voltage reading for the sensor.
8. Ensure header float is unlocked.
9. Start the combine, and fully lower feeder house to the ground.

**NOTE:**

You may need to hold the HEADER DOWN switch for a few seconds to ensure the feeder house is fully lowered.

10. Check the sensor reading on the monitor. The reading should be above 0.5 V.
11. Raise the header so it is just off the ground. The reading on the monitor should read below 4.5 V.
12. If the sensor voltage is not within the low and high limits or if the range between the low and high limits is insufficient, refer to [Adjusting Voltage Limits – One-Sensor System, page 194](#).

### *Calibrating the Auto Header Height Control – John Deere 60 Series*

For best performance of the auto header height control (AHHC), perform these procedures with the center-link set to **D**. When setup and calibration are complete, adjust the center-link back to desired header angle. For instructions, refer to the header operator's manual.

**NOTE:**

Changes may have been made to the combine controls or display since this document was published. Refer to the combine operator's manual for updates.

## SETTING UP AUTO HEADER HEIGHT CONTROL

### WARNING

Check to be sure all bystanders have cleared the area.

#### NOTE:

If the header float is set too light, it can prevent calibration of AHHC. You may need to set the float heavier for calibration procedure so header doesn't separate from the float module.

1. Ensure center-link is set to **D**.
2. Rest header on down stops, and unlock float.
3. Put wings in locked position.
4. Start the combine.
5. Press DIAGNOSTIC button (A) on the monitor. DIA appears on the monitor.
6. Press CAL button (B). DIA-CAL appears on the monitor.



Figure 7.257: John Deere Combine Display

7. Press the UP or DOWN buttons until HDR appears on the monitor.
8. Press the ENTER button. HDR H-DN appears on the monitor.
9. Fully lower feeder house to the ground.

#### NOTE:

You may need to hold the HEADER DOWN switch for a few seconds to ensure the feeder house is fully lowered.

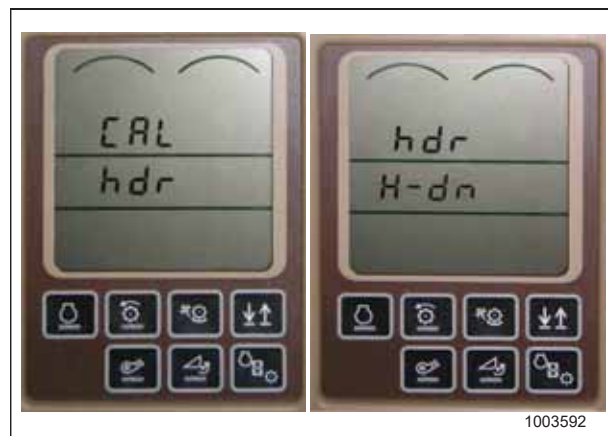

Figure 7.258: John Deere Combine Display

## SETTING UP AUTO HEADER HEIGHT CONTROL

10. Press CAL button (A) to save the calibration of the header. HDR H-UP appears on the monitor.
11. Raise the header 1 m (3 ft.) off the ground and press CAL button (A). EOC appears on the monitor.
12. Press ENTER button (B) to save the calibration of the header. Your AHHC is now calibrated.

### NOTE:

If an error code appears during calibration, the sensor is out of voltage range and will require adjustment. For instructions, refer to *Checking Voltage Range from the Combine Cab – John Deere 60 Series, page 295*.

### NOTE:

After the calibration is complete, adjust combine operation settings to ensure proper field operation.

### NOTE:

If float was set heavier to complete the AHHC calibration procedure, adjust to recommended operating float after the calibration is complete.

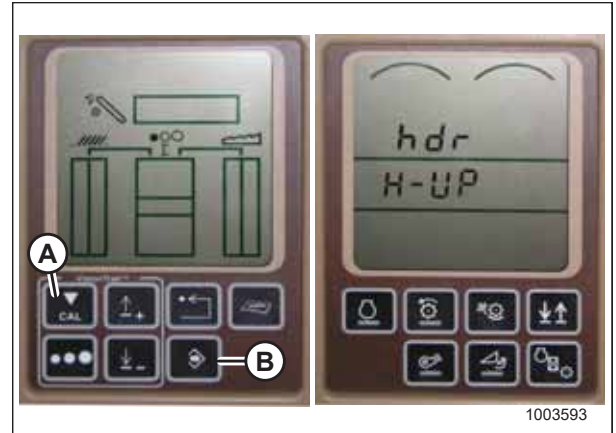

Figure 7.259: John Deere Combine Display

## Turning the Accumulator Off – John Deere 60 Series

The accumulator is a hydraulic device that cushions the shock of hydraulic fluid when installing a heavy header onto the combine.

### NOTE:

Changes may have been made to the combine controls or display since this document was published. Refer to the combine operator's manual for updates.

1. Press DIAGNOSTIC button (A) on the monitor. DIA appears on the monitor.
2. Press UP button (B) until EO1 appears on the monitor, and press ENTER (D). This is the header adjustment.
3. Press UP (B) or DOWN (C) button until 132 is displayed on the top portion of the monitor. This is the reading for the accumulator.
4. Press ENTER (D) to select 132 as the accumulator reading (this will allow you to change the display to a three-digit number so it has a 0 in it, for example, x0x).
5. Press UP (B) or DOWN (C) button until the desired number is displayed, and press CAL button (E).
6. Press ENTER (D) to save the changes. The accumulator is now deactivated.

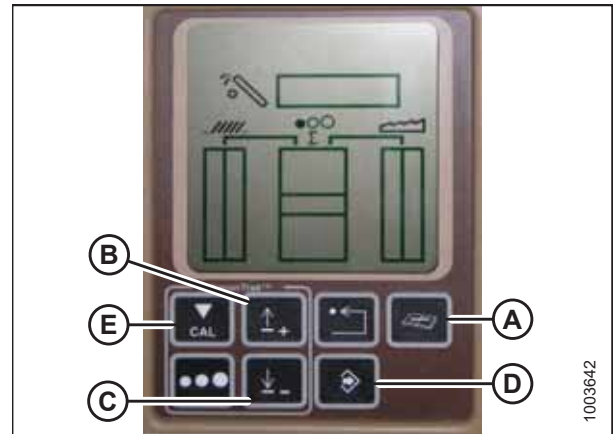

Figure 7.260: John Deere Combine Display

## Setting the Sensing Grain Header Height to 50 – John Deere 60 Series

### NOTE:

Changes may have been made to the combine controls or display since this document was published. Refer to the combine operator's manual for updates.

To set the sensing grain header height, follow these steps:

## SETTING UP AUTO HEADER HEIGHT CONTROL

1. Press DIAGNOSTIC button (A) on the monitor. DIA appears on the monitor.
2. Press UP button (B) until EO1 appears on the monitor, and press ENTER (D). This is the header adjustment.
3. Press UP (B) or DOWN (C) button until 128 is displayed on the top portion of the monitor. This is the reading for the sensor.
4. Press ENTER (D) to select 128 as the sensor reading (this will allow you to change the display to a three-digit number so it has a 50 in it).
5. Press UP (B) or DOWN (C) button until the desired number is displayed, and press CAL button (E).
6. Press ENTER (D) to save the changes. The height is now set.

### NOTE:

Do **NOT** use the active header float function (A) in combination with the MacDon auto header height control (AHHC)—the two systems will counteract one another. Header symbol (B) on the display should **NOT** have a wavy line under it and should appear exactly as shown on the Active Header Control Display in Figure 7.262, page 300.

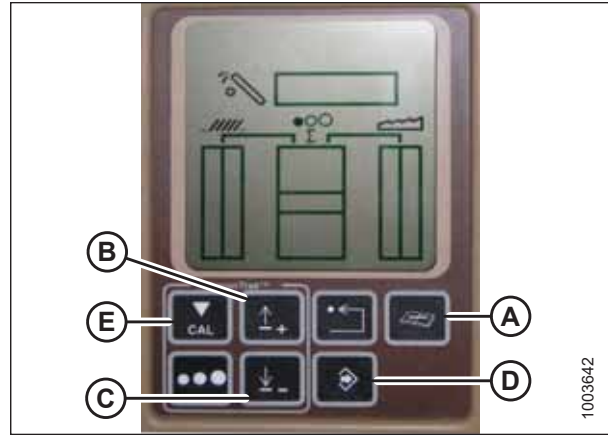

Figure 7.261: John Deere Combine Display

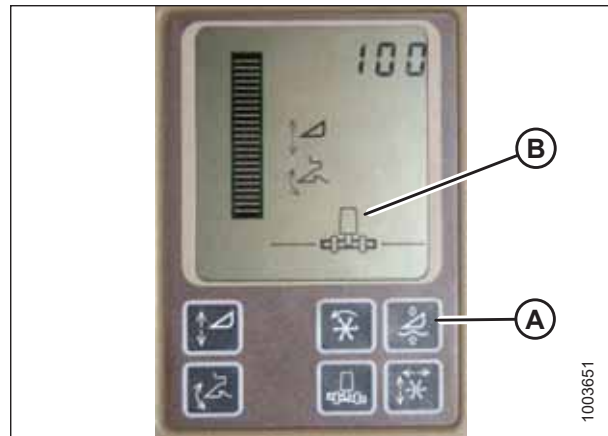

Figure 7.262: John Deere Combine Display

### Setting the Sensitivity of the Auto Header Height Control – John Deere 60 Series

The sensitivity adjustment controls the distance the cutterbar must travel up or down before the auto header height control (AHHC) reacts and raises or lowers the feeder house.

When the sensitivity is set to maximum, only small changes in ground height are needed to cause the feeder house to raise or lower. When the sensitivity is set to minimum, large changes in the ground height are needed to cause the feeder house to raise or lower.

### NOTE:

Changes may have been made to the combine controls or display since this document was published. Refer to the combine operator's manual for updates.



## SETTING UP AUTO HEADER HEIGHT CONTROL

1. Press DIAGNOSTIC button (A) on the monitor. DIA appears on the monitor.
2. Press UP button (B) until EO1 appears on the monitor, and press ENTER (D). This is the header adjustment.
3. Press UP (B) or DOWN (C) button until 112 is displayed on the monitor. This is your sensitivity setting.

**NOTE:**

The lower the reading, the higher the sensitivity. Ideal operating range is typically between 50 and 80.

4. Press ENTER (D) to select 112 as the sensitivity setting (this will allow you to change the first digit of the number sequence).
5. Press UP (B) or DOWN (C) until the desired number is displayed, then press CAL button (E). This will bring you to the second digit. Repeat this procedure until the desired setting is achieved.
6. Press ENTER (D) to save changes.

**NOTE:**

The numbers shown on the displays in these illustrations are for reference purposes only; they are not intended to represent the specific settings for your equipment.

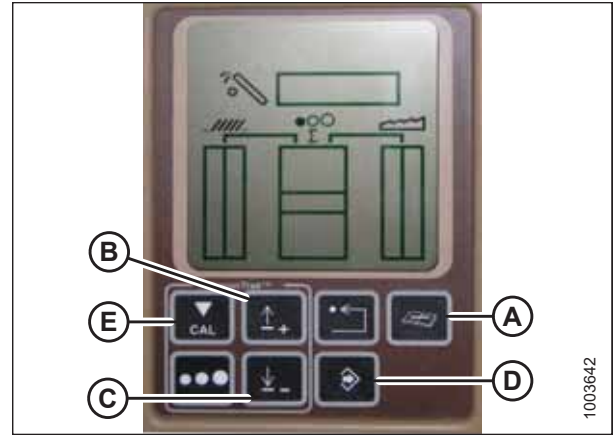

Figure 7.263: John Deere Combine Display

### *Adjusting the Threshold for the Drop Rate Valve – John Deere 60 Series*

This procedure explains how to adjust the point at which the restrictor valve opens allowing full flow to the lift cylinders.

**NOTE:**

Changes may have been made to the combine controls or display since this document was published. Refer to the combine operator's manual for updates.

**NOTE:**

The numbers shown on the displays in these illustrations are for reference purposes only; they are not intended to represent the specific settings for your equipment.

1. Press DIAGNOSTIC button (A) on the monitor. DIA appears on the monitor.
2. Press UP button (B) until EO1 appears on the monitor and press ENTER (C). This is the header adjustment.
3. Press UP (B) or DOWN button until 114 is displayed on the top portion of the monitor. This is the setting that adjusts when the fast drop rate starts with respect to the dead band.

**NOTE:**

The default setting is 100. Ideal operating range is typically between 60 and 85.

4. Press ENTER (C) to select 114 as the fast drop rate (this will allow you to change the first digit of the number sequence).

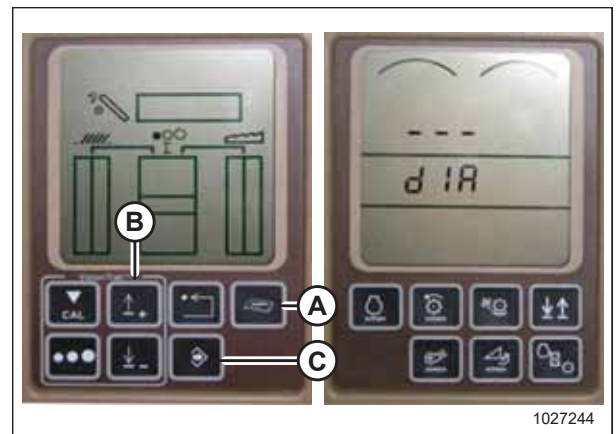

Figure 7.264: John Deere Combine Display

## SETTING UP AUTO HEADER HEIGHT CONTROL

5. Press UP (A) or DOWN (B) until the desired number is displayed, then press CAL button (C). This will bring you to the second digit. Repeat this procedure until the desired setting is achieved.
6. Press ENTER (D) to save changes.

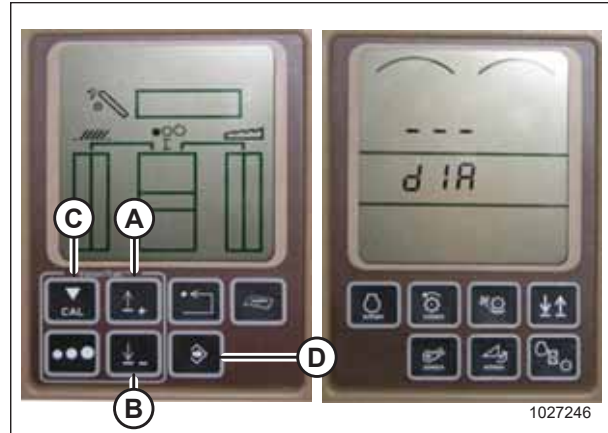

Figure 7.265: John Deere Combine Display

### 7.1.15 John Deere 70 Series Combines

#### Checking Voltage Range from the Combine Cab – John Deere 70 Series

**NOTE:**

Changes may have been made to the combine controls or display since this document was published. Refer to the combine operator's manual for updates.

**WARNING**

Check to be sure all bystanders have cleared the area.

1. Position the header 150 mm (6 in.) above the ground, and unlock the float.
2. Check that float lock linkage is on down stops (washer [A] cannot be moved) at both locations.

**NOTE:**

If the header is not on down stops during the next two steps, the voltage may go out of range during operation causing a malfunction of the AHHC system.

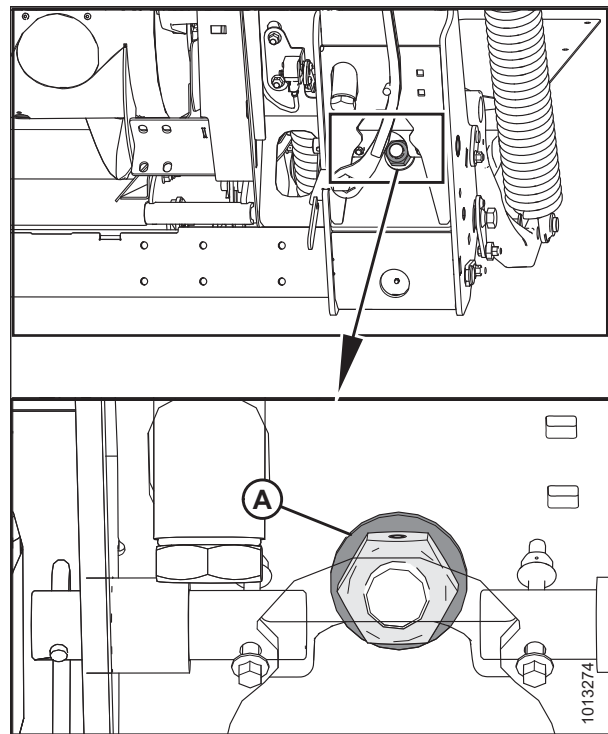

Figure 7.266: Float Lock

## SETTING UP AUTO HEADER HEIGHT CONTROL

- Adjust cable take-up bracket (B) (if necessary) until pointer (A) on the float indicator is on 0.

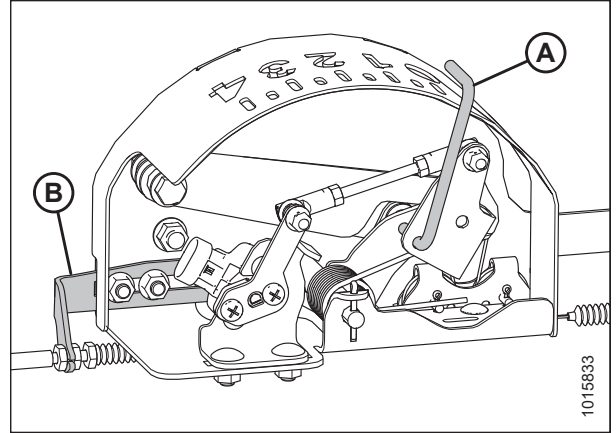

Figure 7.267: Float Indicator Box

- Press HOME PAGE button (A) on the main screen of the monitor.



Figure 7.268: John Deere Combine Display

- Ensure three icons (A) shown in the illustration at right appear on the monitor.



Figure 7.269: John Deere Combine Display

## SETTING UP AUTO HEADER HEIGHT CONTROL

- Use scroll knob (A) to highlight the middle icon (the green i) and press check mark button (B) to select it. This will bring up the Message Center.

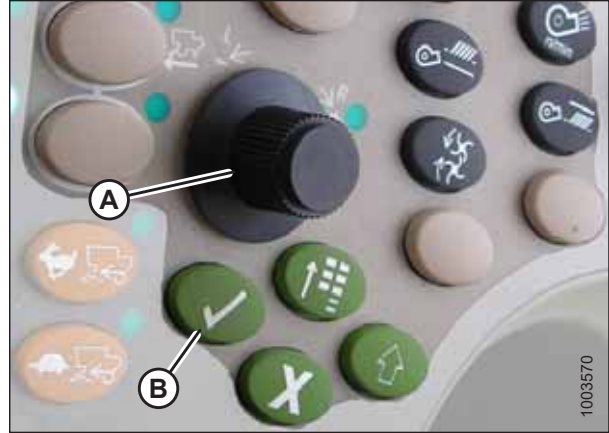

Figure 7.270: John Deere Combine Control Console

- Use the scroll knob to highlight DIAGNOSTIC ADDRESSES (A) from the right column and select it by pressing the check mark button.
- Use the scroll knob to highlight drop-down box (B) and press the check mark button to select it.



Figure 7.271: John Deere Combine Display

- Use the scroll knob to highlight LC 1.001 VEHICLE (A) and press the check mark button to select it.



Figure 7.272: John Deere Combine Display

## SETTING UP AUTO HEADER HEIGHT CONTROL

- Use the scroll knob to highlight down arrow (A) and press the check mark button to scroll through the list until 029 DATA (B) is displayed and voltage reading (C) appears on the monitor.



Figure 7.273: John Deere Combine Display

- Ensure the header float is unlocked.
- Start the combine and fully lower the feeder house to the ground.  
**NOTE:**  
You may need to hold the HEADER DOWN switch for a few seconds to ensure the feeder house is fully lowered.
- Check the sensor reading on the monitor.
- Raise the header so it is just off the ground and recheck the sensor reading.
- If the sensor voltage is not within the low and high limits or if the range between the low and high limits is insufficient, refer to [Adjusting Voltage Limits – One-Sensor System, page 194](#).

### Calibrating Feeder House Speed – John Deere 70 Series

The feeder house speed must be calibrated before you calibrate the auto header height control (AHHC) system. For instructions, refer to the combine operator's manual.

### Calibrating the Auto Header Height Control – John Deere 70 Series

For best performance of the auto header height control (AHHC), perform these procedures with the center-link set to **D**. When setup and calibration are complete, adjust the center-link back to desired header angle. For instructions, refer to Header Angle in the header operator's manual for instructions.

#### **NOTE:**

Changes may have been made to the combine controls or display since this document was published. Refer to the combine operator's manual for updates.



## **WARNING**

Check to be sure all bystanders have cleared the area.

#### **NOTE:**

If header float is set too light, it can prevent calibration of AHHC. You may need to set the float heavier for calibration procedure so header doesn't separate from the float module.

- Ensure center-link is set to **D**.
- Rest header on down stops and unlock float.
- Place wings in locked position.

## SETTING UP AUTO HEADER HEIGHT CONTROL

4. Start the combine.
5. Press the button located fourth from the left along the top of monitor (A) to select the icon that resembles an open book with a wrench on it (B).
6. Press top button (A) a second time to enter diagnostics and calibration mode.



Figure 7.274: John Deere Combine Display

7. Select HEADER in box (A) by scrolling down to the box using the scroll knob, and then pressing the check mark button (knob and button are shown in Figure 7.276, page 306).
8. Scroll down to the lower right icon that resembles an arrow in a diamond (B) and press the check mark button to select it.

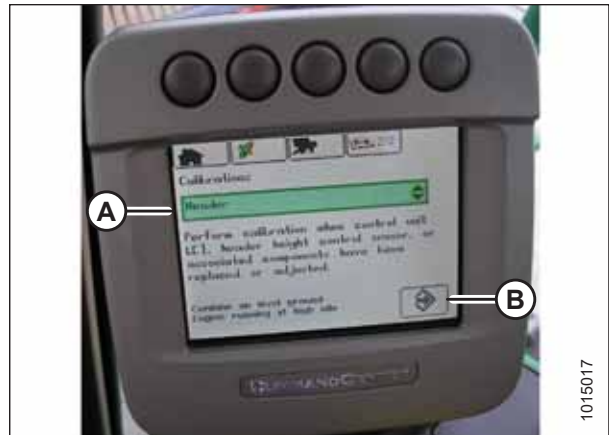

Figure 7.275: John Deere Combine Display

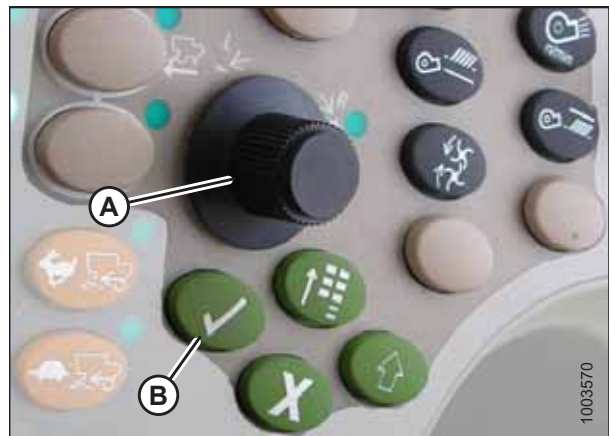

Figure 7.276: John Deere Combine Control Console

A - Scroll Knob

B - Check Mark Button

9. Follow the steps listed on the monitor to perform the calibration.

## SETTING UP AUTO HEADER HEIGHT CONTROL

**NOTE:**

If an error code appears on screen, the sensor is not in the correct working range. Check and adjust the range. For instructions, refer to *Checking Voltage Range from the Combine Cab – John Deere S and T Series, page 309*.

**NOTE:**

If float was set heavier to complete the AHHC calibration procedure, adjust to recommended operating float after the calibration is complete.

## SETTING UP AUTO HEADER HEIGHT CONTROL

### *Setting the Sensitivity of the Auto Header Height Control – John Deere 70 Series*

The sensitivity adjustment controls the distance the cutterbar must travel up or down before the auto header height control (AHHC) reacts and raises or lowers the feeder house.

When the sensitivity is set to maximum, only small changes in ground height are needed to cause the feeder house to raise or lower. When the sensitivity is set to minimum, large changes in the ground height are needed to cause the feeder house to raise or lower.

#### **NOTE:**

Changes may have been made to the combine controls or display since this document was published. Refer to the combine operator's manual for updates.

1. Press button (A) twice. The current sensitivity setting will appear on the monitor (the lower the reading, the lower the sensitivity).
2. Use scroll knob (B) to adjust the sensitivity setting. The adjustment will be saved automatically.

#### **NOTE:**

If the screen remains idle for a short period of time, it will automatically return to the previous screen. Pressing check mark button (C) also will return the monitor to the previous screen.

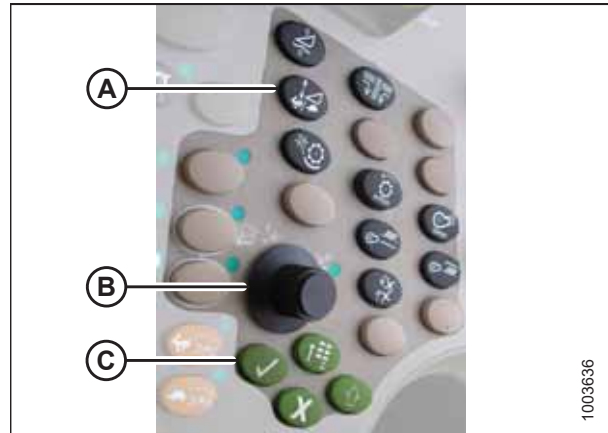

Figure 7.277: John Deere Combine Control Console

1003636

#### **NOTE:**

The numbers shown on the displays in these illustrations are for reference purposes only; they are not intended to represent the specific settings for your equipment.



Figure 7.278: John Deere Combine Display

1003637

### *Adjusting the Manual Header Raise/Lower Rate – John Deere 70 Series*

The weight of the header will dictate the rate at which the header can be raised or lowered during operation.

To manually adjust the header raise/lower rate, do the following steps:

#### **NOTE:**

Changes may have been made to the combine controls or display since this document was published. Refer to the combine operator's manual for updates.



## SETTING UP AUTO HEADER HEIGHT CONTROL

1. Press button (A) and the current raise/lower rate setting will appear on the monitor (the lower the reading, the slower the rate).
2. Use scroll knob (B) to adjust the rate. The adjustment will be saved automatically.

**NOTE:**

If the screen remains idle for a short period of time, it will automatically return to the previous screen. Pressing check mark button (C) will also return the monitor to the previous screen.

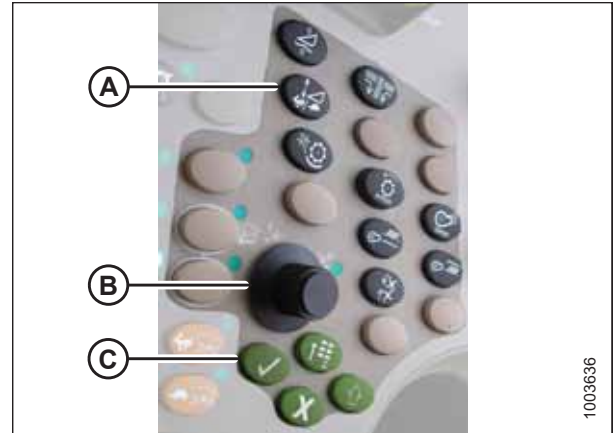

Figure 7.279: John Deere Combine Control Console

**NOTE:**

The numbers shown on the displays in these illustrations are for reference purposes only; they are not intended to represent the specific settings for your equipment.



Figure 7.280: John Deere Combine Display

### 7.1.16 John Deere S and T Series Combines

#### *Checking Voltage Range from the Combine Cab – John Deere S and T Series*

**NOTE:**

Changes may have been made to the combine controls or display since this document was published. Refer to the combine operator's manual for updates.



### **WARNING**

**Check to be sure all bystanders have cleared the area.**

1. Position the header 150 mm (6 in.) above the ground, and unlock the float.

## SETTING UP AUTO HEADER HEIGHT CONTROL

2. Check that float lock linkage is on down stops (washer [A] cannot be moved) at both locations.

**NOTE:**

If the header is not on down stops during the next two steps, the voltage may go out of range during operation causing a malfunction of the AHHC system.

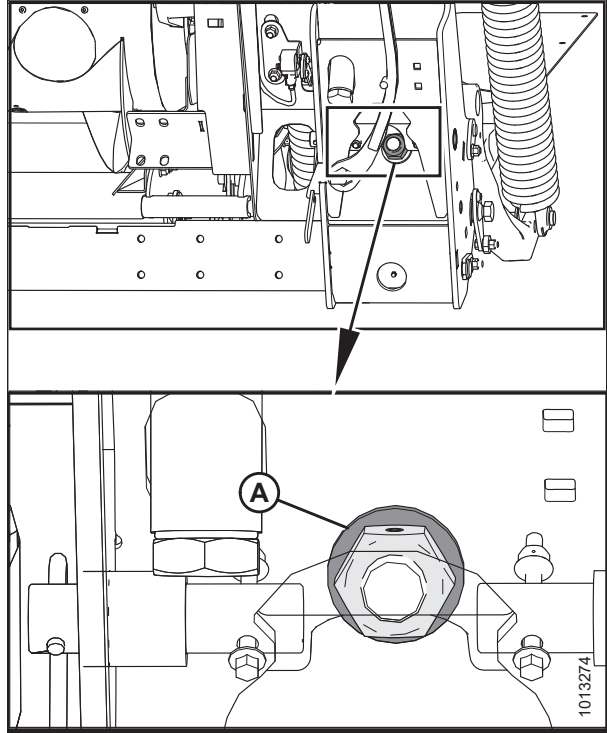

Figure 7.281: Float Lock

3. Adjust cable take-up bracket (B) (if necessary) until pointer (A) on the float indicator is on 0.

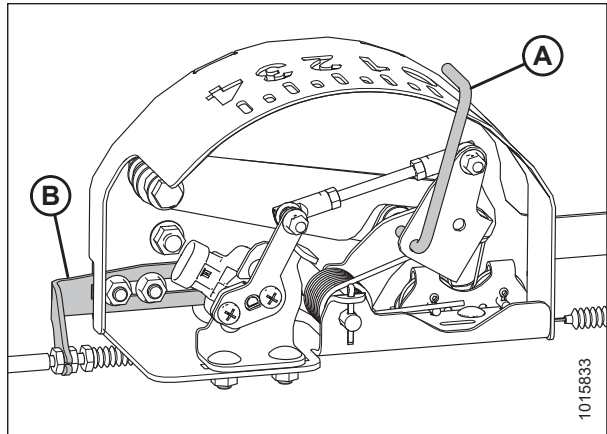

Figure 7.282: Float Indicator Box

## SETTING UP AUTO HEADER HEIGHT CONTROL

4. Press CALIBRATION icon (A) on the main screen of the monitor. The CALIBRATION screen appears.



Figure 7.283: John Deere Combine Display

5. Press DIAGNOSTIC READINGS icon (A) on the CALIBRATION screen. The DIAGNOSTIC READINGS screen appears. This screen provides access to calibrations, header options, and diagnostic information.

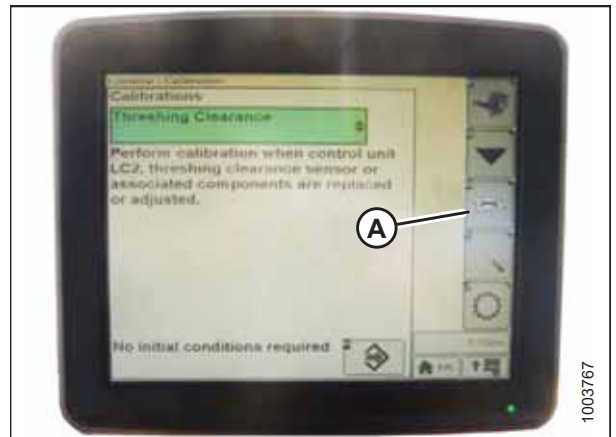

Figure 7.284: John Deere Combine Display

6. Select AHHC RESUME (A) and a list of calibration options appears.



Figure 7.285: John Deere Combine Display

## SETTING UP AUTO HEADER HEIGHT CONTROL

7. Select the AHHC SENSING option.
8. Press icon (A) displayed on screen. The AHHC SENSING menu appears and five screens of information are displayed.



Figure 7.286: John Deere Combine Display

9. Press icon (A) until it reads Page 5 near the top of the screen and the following sensor readings appear:
  - LEFT HEADER HEIGHT
  - CENTER HEADER HEIGHT
  - RIGHT HEADER HEIGHT

A reading is displayed for both left and right sensors. On the MacDon header, there may be one sensor located in the float indicator box (standard) or two sensors located at the back of the float module side frame (optional).



Figure 7.287: John Deere Combine Display

10. Ensure header float is unlocked.
11. Start the combine and fully lower feeder house to the ground.

### NOTE:

You may need to hold the HEADER DOWN switch for a few seconds to ensure the feeder house is fully lowered.

12. Check the sensor reading on the monitor.
13. If the sensor voltage is not within the low and high limits or if the range between the low and high limits is insufficient, refer to [Adjusting Voltage Limits – One-Sensor System, page 194](#).

## SETTING UP AUTO HEADER HEIGHT CONTROL

### Calibrating the Auto Header Height Control – John Deere S and T Series

For best performance of the auto header height control (AHHC), perform these procedures with the center-link set to **D**. When setup and calibration are complete, adjust the center-link back to desired header angle. For instructions, refer to Header Angle in the header operator's manual.

#### NOTE:

Changes may have been made to the combine controls or display since this document was published. Refer to the combine operator's manual for updates.

#### NOTE:

If header float is set too light, it can prevent calibration of AHHC. You may need to set the float heavier for calibration procedure so header doesn't separate from the float module.

1. Ensure center-link is set to **D**.
2. Rest header on down stops and unlock float.
3. Place wings in locked position.
4. Press DIAGNOSTIC icon (A) on the main screen of the monitor. The CALIBRATION screen appears.



Figure 7.288: John Deere Combine Display

5. Select THRESHING CLEARANCE (A) and a list of calibration options appears.

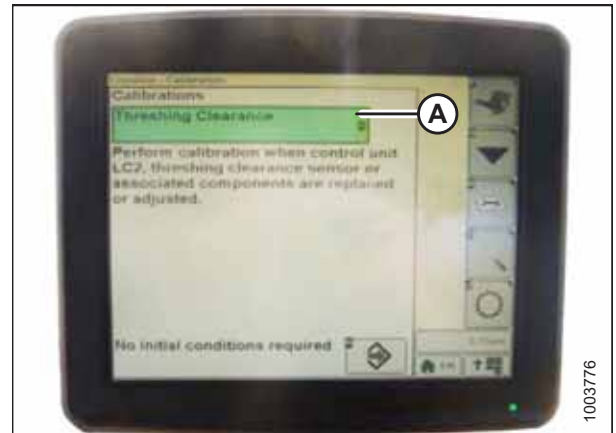

Figure 7.289: John Deere Combine Display

## SETTING UP AUTO HEADER HEIGHT CONTROL

6. Select FEEDER HOUSE SPEED (A) from the list of calibration options.

**NOTE:**

Feeder house speed calibration must be done before header calibration.



Figure 7.290: John Deere Combine Display

7. With FEEDER HOUSE SPEED selected, press icon (A). The icon will turn green.



Figure 7.291: John Deere Combine Display

8. Press icon (A) and instructions will appear on screen to guide you through the remaining calibration steps.



Figure 7.292: John Deere Combine Display

## SETTING UP AUTO HEADER HEIGHT CONTROL

9. Select HEADER (A) from the list of calibration options.

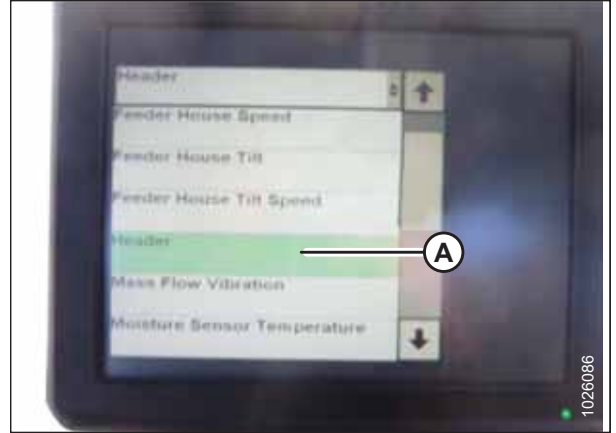

Figure 7.293: John Deere Combine Display

10. With HEADER selected, press icon (A). The icon will turn green.

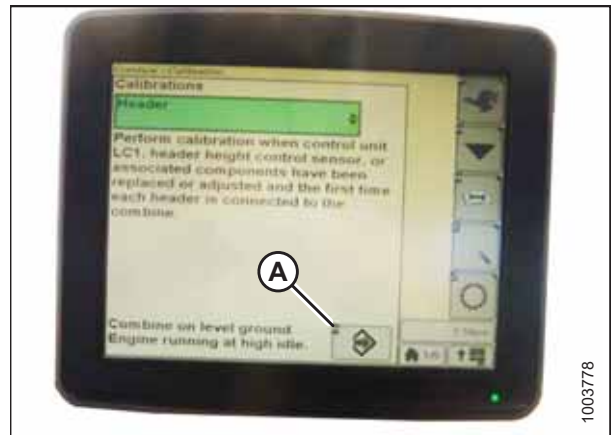

Figure 7.294: John Deere Combine Display

11. Press icon (A) and instructions will appear on screen to guide you through the remaining calibration steps.

**NOTE:**

If an error code appears during calibration, the sensor is out of voltage range and will require adjustment. For instructions, refer to [Checking Voltage Range from the Combine Cab – John Deere S and T Series, page 309](#).

**NOTE:**

If float was set heavier to complete the AHHC calibration procedure, adjust to recommended operating float after the calibration is complete.



Figure 7.295: John Deere Combine Display

## SETTING UP AUTO HEADER HEIGHT CONTROL

### *Setting the Sensitivity of the Auto Header Height Control – John Deere S and T Series*

The sensitivity adjustment controls the distance the cutterbar must travel up or down before the auto header height control (AHHC) reacts and raises or lowers the feeder house.

When the sensitivity is set to maximum, only small changes in ground height are needed to cause the feeder house to raise or lower. When the sensitivity is set to minimum, large changes in the ground height are needed to cause the feeder house to raise or lower.

#### **NOTE:**

Changes may have been made to the combine controls or display since this document was published. Refer to the combine operator's manual for updates.

1. Press button (A) twice and the current sensitivity setting will appear on the monitor.



Figure 7.296: John Deere Combine Command Center

2. Press – or + icons (A) to adjust rates.

#### **NOTE:**

The numbers shown on the combine display in this illustration are for reference purposes only; they are not intended to represent the specific settings for your equipment.



Figure 7.297: John Deere Combine Display



## SETTING UP AUTO HEADER HEIGHT CONTROL

### *Adjusting the Manual Header Raise/Lower Rate – John Deere S and T Series*

#### **NOTE:**

Changes may have been made to the combine controls or display since this document was published. Refer to the combine operator's manual for updates.

1. Ensure indicator (A) is at position 0 (B) with the header 152 mm (6 in.) off the ground. If not, the float sensor output voltage should be checked. Refer to Step 5, page 190.

#### **NOTE:**

When the header is on the ground, the indicator should be at position 1 (C) for low ground pressure, and at position 4 (D) for high ground pressure. Crop and soil conditions determine the amount of float to use. The ideal setting is as light as possible without header bouncing or missing crop. Operating with heavy settings prematurely wears the cutterbar wearplates.

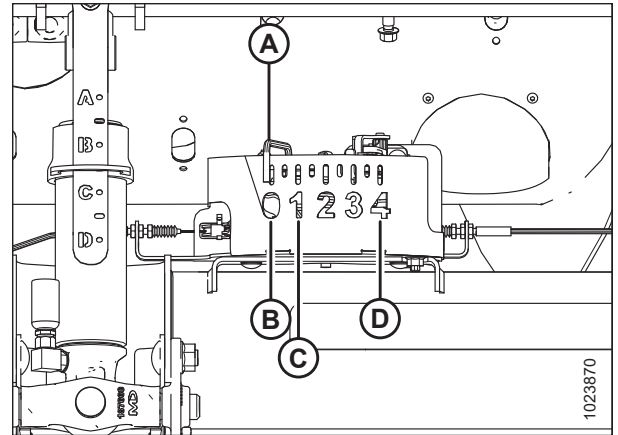

Figure 7.298: Float Indicator Box

2. Press button (A) and the current sensitivity setting will appear on the monitor.



Figure 7.299: John Deere Combine Command Center

3. Press – or + icons (A) to adjust rates.

#### **NOTE:**

The numbers shown on the combine display in this illustration are for reference purposes only; they are not intended to represent the specific settings for your equipment.

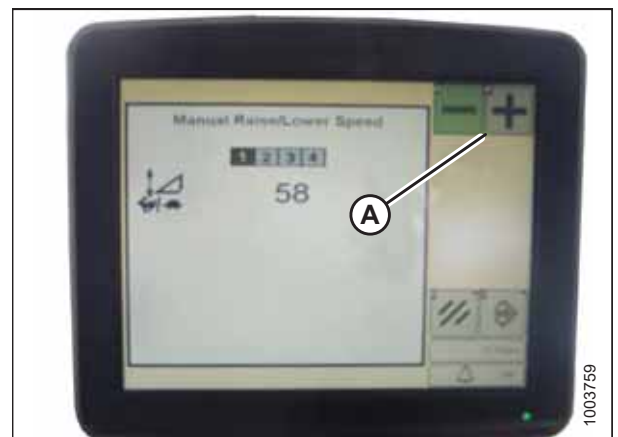

Figure 7.300: John Deere Combine Display

## SETTING UP AUTO HEADER HEIGHT CONTROL

### Setting Preset Cutting Height – John Deere S and T Series

#### NOTE:

Changes may have been made to the combine controls or display since this document was published. Refer to the combine operator's manual for updates.

1. Ensure indicator (A) is at position 0 (B) with the header (152 mm [6 in.]) off the ground. If not, the float sensor output voltage should be checked. Refer to Step 5, page 190.

#### NOTE:

When the header is on the ground, the indicator should be at position 1 (C) for low ground pressure, and at position 4 (D) for high ground pressure. Crop and soil conditions determine the amount of float to use. The ideal setting is as light as possible without header bouncing or missing crop. Operating with heavy settings prematurely wears the cutterbar wearplates.

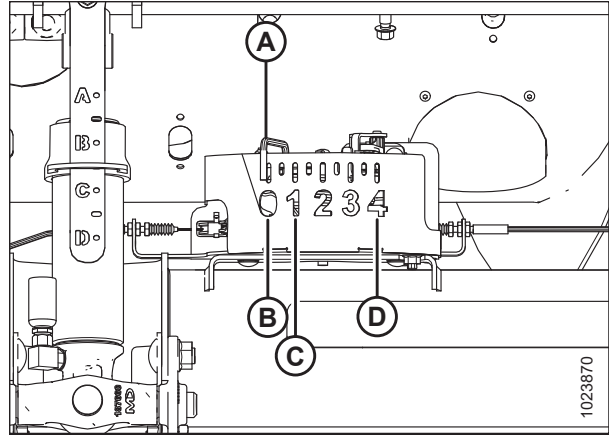

Figure 7.301: Float Indicator Box

2. Press COMBINE – HEADER SETUP icon (A) on the main screen. The COMBINE – HEADER SETUP screen appears. This screen is used to set various header settings such as reel speed, header width, and height of feeder house for acre counter engagement.



Figure 7.302: Combine Display

3. Select COMBINE – HEADER SETUP AHC icon (A). The COMBINE – HEADER SETUP AHC screen appears.



Figure 7.303: Combine Display

## SETTING UP AUTO HEADER HEIGHT CONTROL

4. Select AUTO HEIGHT SENSING (A), RETURN TO CUT (B), and REEL POSITION (C) icons.

**NOTE:**

If REEL POSITION icon (C) cannot be selected (no check mark), the reel height sensor requires calibration. For instructions, refer to *Calibrating Reel Height Sensor – John Deere S and T Series, page 325*.

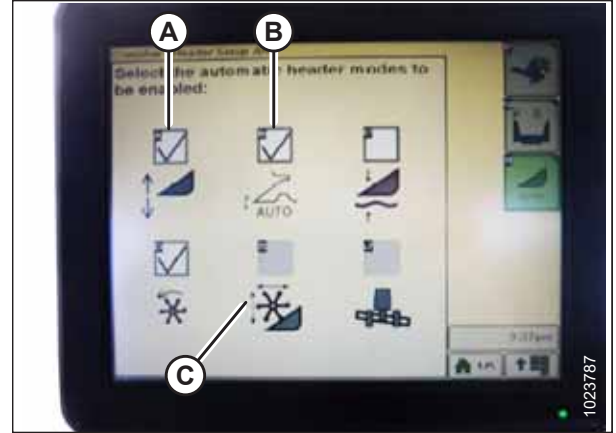

Figure 7.304: Combine Display

5. Engage the header.
6. Move the header to the desired position and use knob (A) to fine tune the position.
7. Move the reel to the desired position.



Figure 7.305: Combine Control Console

8. Press and hold preset switch 2 (B) until 1 reel height icon flashes on monitor.
9. Repeat previous three steps for preset switch 3 (C).
10. Select an appropriate ground pressure setting. Use preset button 2 (B) on the control handle for a low ground pressure setting in muddy or soft soil conditions, and preset 3 (C) for a high ground pressure setting in firm soil conditions and a higher ground speed.

**NOTE:**

Preset button 1 (A) is reserved for header lift on the headland and is not used for cutting on ground.



Figure 7.306: Control Handle Buttons

## SETTING UP AUTO HEADER HEIGHT CONTROL

### NOTE:

When the AHHC is engaged, AHHC icon (A) appears on the monitor and the number indicating which button was pressed (B) is displayed on the screen.

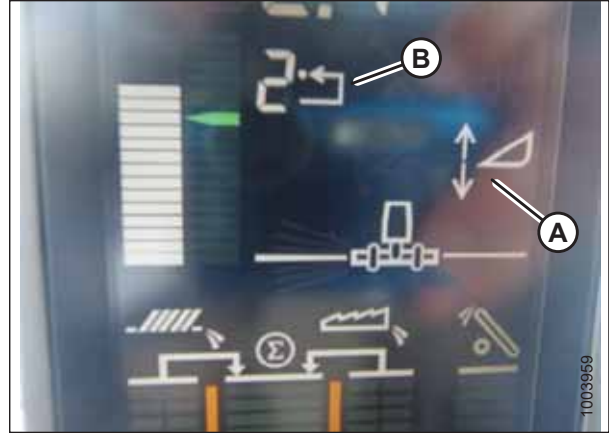

Figure 7.307: Combine Display

### *Calibrating Feeder House Fore-Aft Tilt Range – John Deere S and T Series*

For best performance of the auto header height control (AHHC), perform these procedures with the center-link set to **D**. When setup and calibration are complete, adjust the center-link back to desired header angle. For instructions, refer to the header operator's manual.

This procedure applies only to model year 2015 and later John Deere S and T Series combines.

### NOTE:

Changes may have been made to the combine controls or display since this document was published. Refer to the combine operator's manual for updates.

The feeder house fore/aft tilt is controlled by buttons (C) and (D) at the back of the control handle.



Figure 7.308: John Deere Control Handle

## SETTING UP AUTO HEADER HEIGHT CONTROL

### NOTE:

The feeder house fore/aft tilt controls can be changed to work with buttons E and F by pressing control handle icon (A) and then selecting FEEDER HOUSE FORE/AFT TILT from drop-down menu (B).

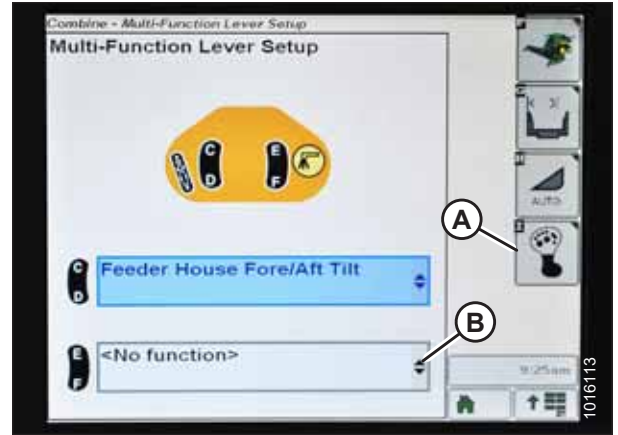

Figure 7.309: John Deere Combine Display

To calibrate the feeder house fore-aft tilt range, follow these steps:

1. Ensure center-link is set to **D**.
2. Rest header on down stops and unlock float.
3. Place wings in locked position.
4. Press DIAGNOSTIC icon (A) on the main screen of the monitor. The CALIBRATION screen displays.



Figure 7.310: John Deere Combine Display

5. Select CALIBRATIONS drop-down menu (A) to view the list of calibration options.

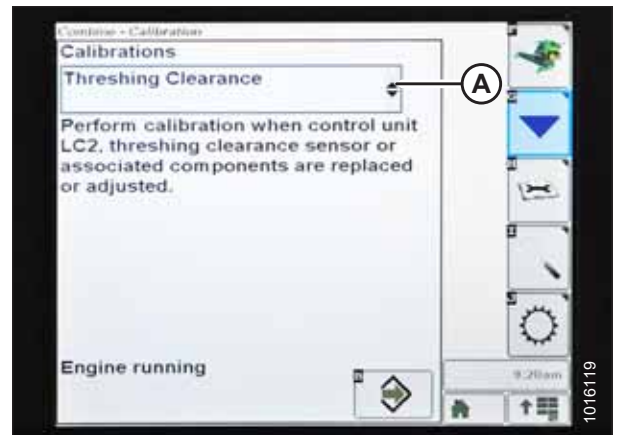

Figure 7.311: John Deere Combine Display

## SETTING UP AUTO HEADER HEIGHT CONTROL

- Press arrow (A) to cycle up through the calibration options and select FEEDER HOUSE FORE/AFT TILT RANGE.

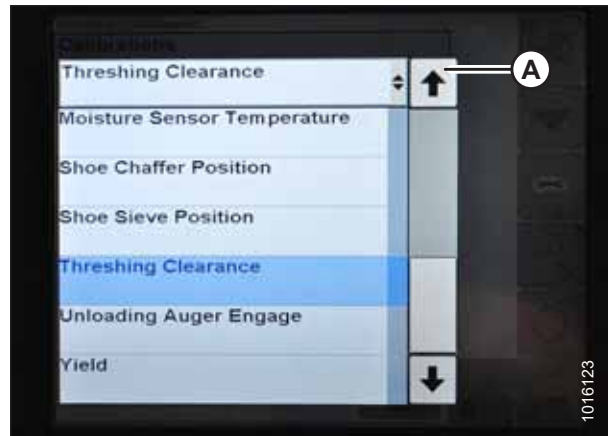

Figure 7.312: John Deere Combine Display

- Press ENTER icon (A).

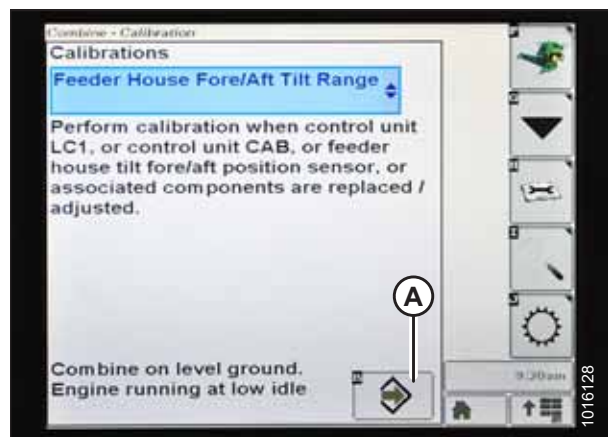

Figure 7.313: John Deere Combine Display

- Follow the instructions that appear on the screen. As you proceed through the calibration process, the display will automatically update to show the next step.

### NOTE:

If an error code appears during calibration, the sensor is out of voltage range and will require adjustment. For instructions, refer to [Checking Voltage Range from the Combine Cab – John Deere S and T Series, page 309](#).

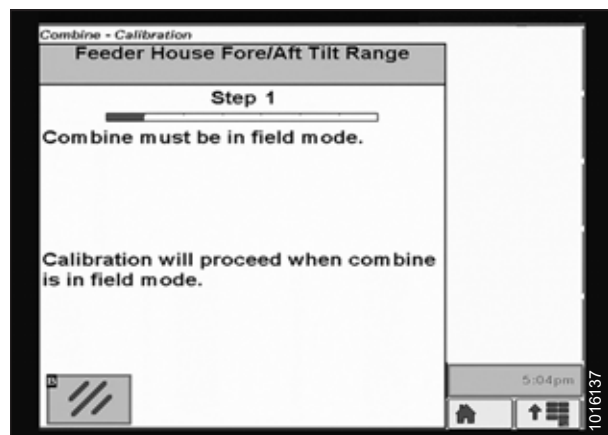

Figure 7.314: John Deere Combine Display

## SETTING UP AUTO HEADER HEIGHT CONTROL

### Checking Reel Height Sensor Voltages – John Deere S and T Series

#### NOTE:

Changes may have been made to the combine controls or display since this document was published. Refer to the combine operator's manual for updates.

1. Press CALIBRATION icon (A) on the main screen of the monitor. The CALIBRATION screen appears.

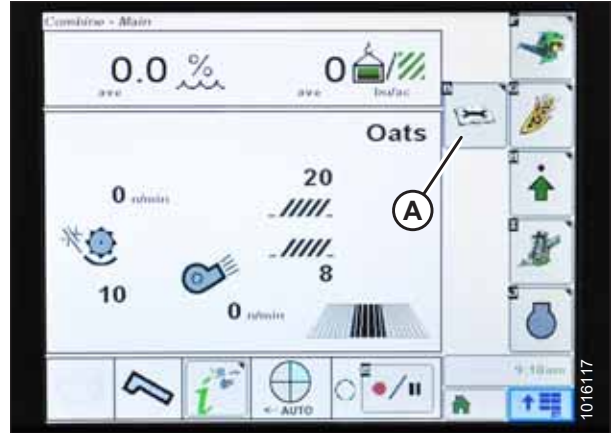

Figure 7.315: John Deere Combine Display

2. Press DIAGNOSTIC READINGS icon (A) on the CALIBRATION screen. The DIAGNOSTIC READINGS screen appears. This screen provides access to calibrations, header options, and diagnostic information.

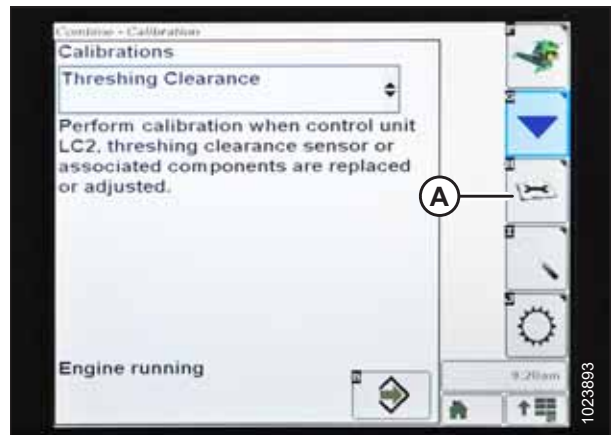

Figure 7.316: John Deere Combine Display

3. Select drop-down menu (A) to view the list of calibration options.

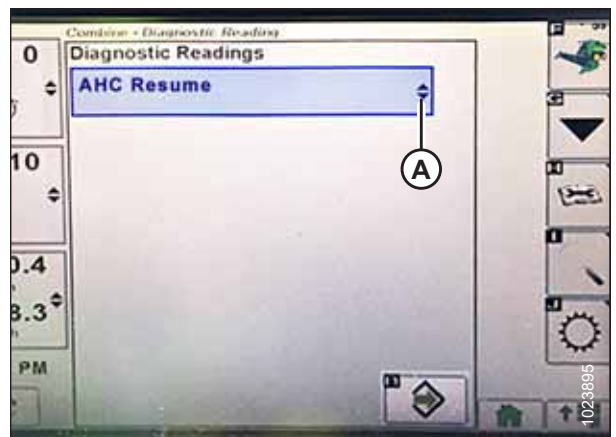

Figure 7.317: John Deere Combine Display

## SETTING UP AUTO HEADER HEIGHT CONTROL

4. Scroll down and select REEL RESUME (A).



Figure 7.318: John Deere Combine Display

5. Press ENTER icon (A). The REEL RESUME page displays.

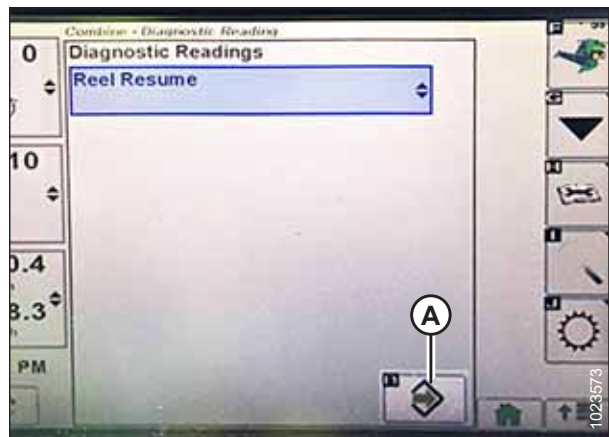

Figure 7.319: John Deere Combine Display

6. Press NEXT PAGE icon (A) to cycle to page 3.
7. Lower the reel to view low voltage (B). The voltage should be 0.5–0.9 V.

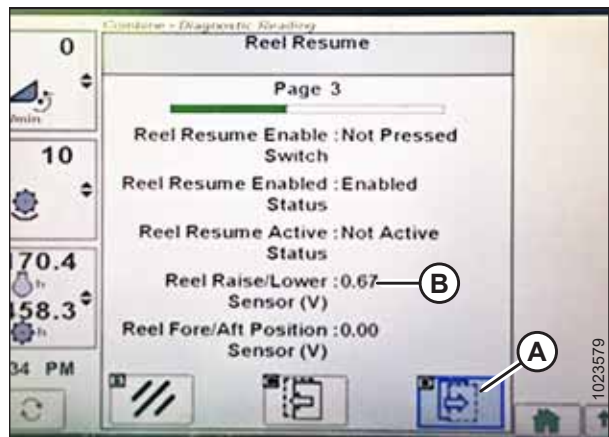

Figure 7.320: John Deere Combine Display



## SETTING UP AUTO HEADER HEIGHT CONTROL

8. Raise the reel to view high voltage (A). The voltage should be 4.1–4.5 V.
9. If either voltage is not within the correct range, refer to [8.1 Checking and Adjusting Reel Height Sensor, page 365](#).

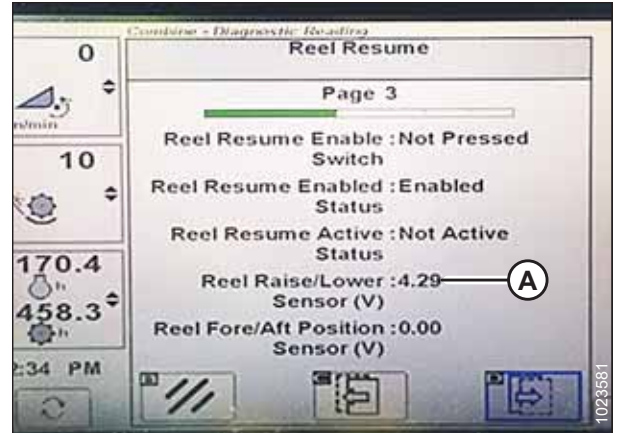

Figure 7.321: John Deere Combine Display

### Calibrating Reel Height Sensor – John Deere S and T Series

This procedure applies only to model year 2015 and later John Deere S and T Series combines.

#### NOTE:

Changes may have been made to the combine controls or display since this document was published. Refer to the combine operator's manual for updates.

To calibrate reel height, follow these steps:

1. Position the header until it is 15–25 cm (6–10 in.) off the ground.

#### IMPORTANT:

Do **NOT** turn off the engine. The combine has to be at full idle for the sensors to calibrate properly.

2. Press DIAGNOSTIC icon (A) on the main screen of the monitor. The CALIBRATION screen displays.



Figure 7.322: John Deere Combine Display

## SETTING UP AUTO HEADER HEIGHT CONTROL

3. Select CALIBRATIONS drop-down menu (A) to view the list of calibration options.
4. Scroll through the list of options and select REEL POSITION.
5. Press ENTER icon (B).

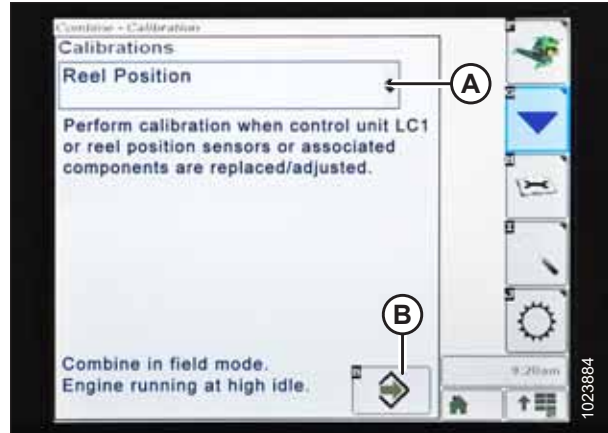

Figure 7.323: John Deere Combine Display

6. Follow the instructions that appear on the screen. As you proceed through the calibration process, the display will automatically update to show the next step. This calibration requires you to use reel raise (A) and reel lower (B) switches on the control handle.



Figure 7.324: John Deere Control Handle

7. Press and hold REEL LOWER switch until reel is fully lowered. Continue holding REEL LOWER switch until prompted by the display.



Figure 7.325: John Deere Combine Display

## SETTING UP AUTO HEADER HEIGHT CONTROL

- Press and hold REEL RAISE switch until reel is fully raised. Continue holding REEL RAISE switch until prompted by the display.



Figure 7.326: John Deere Combine Display

- When all steps have been completed, CALIBRATION COMPLETE message is displayed on the screen. Exit the CALIBRATION menu by pressing ENTER icon (A).

**NOTE:**

If an error code appears during calibration, the sensor is out of voltage range and will require adjustment. For instructions, refer to *Checking Reel Height Sensor Voltages – John Deere S and T Series, page 323*.



Figure 7.327: John Deere Combine Display

### 7.1.17 John Deere S7 Series Combines

#### Setting up Header – John Deere S7 Series

**NOTE:**

Changes may have been made to combine controls or display since this document was published. Refer to combine operator's manual for updates.

- Press header button (A) on the panel below the display. The HEADER page opens.



Figure 7.328: John Deere S7 Display

## SETTING UP AUTO HEADER HEIGHT CONTROL

2. Select HEADER TYPE field (A). The HEADER DETAILS window opens.



Figure 7.329: John Deere S7 Display – Header Page

3. Verify correct header width is displayed under WIDTH.
4. To change header width, select field (A). The WIDTH window opens.



Figure 7.330: John Deere S7 Display – Header Details Window

5. Use the on-screen keypad to enter the correct header width, and then press OK.



Figure 7.331: John Deere S7 Display – Setting Header Width

## SETTING UP AUTO HEADER HEIGHT CONTROL

- Press window close button (A) in top right corner of the window to return to the HEADER page.



Figure 7.332: John Deere S7 Display – Header Details Window

- Raise/lower speed (A), tilt speed (B), height sensitivity (C), and tilt sensitivity (D) can all be adjusted from this page. Select the option you would like to adjust. The following example shows the raise/lower speed adjustment.

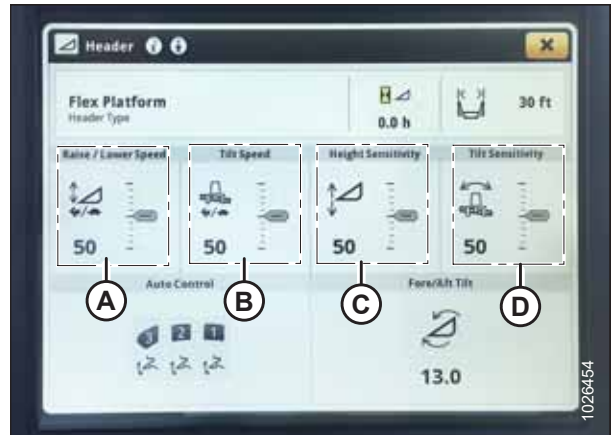

Figure 7.333: John Deere S7 Display – Header Page

- Use + and – buttons (A) to adjust the setting.
- Press window close button in top right corner of the window to return to the HEADER page.

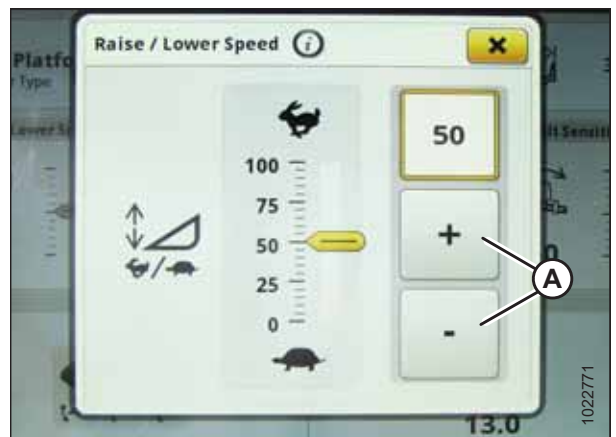

Figure 7.334: John Deere S7 Display – Raise/Lower Speed Adjustment

## SETTING UP AUTO HEADER HEIGHT CONTROL

10. Select AUTO CONTROL icons (A). The AUTO HEADER CONTROLS page opens.

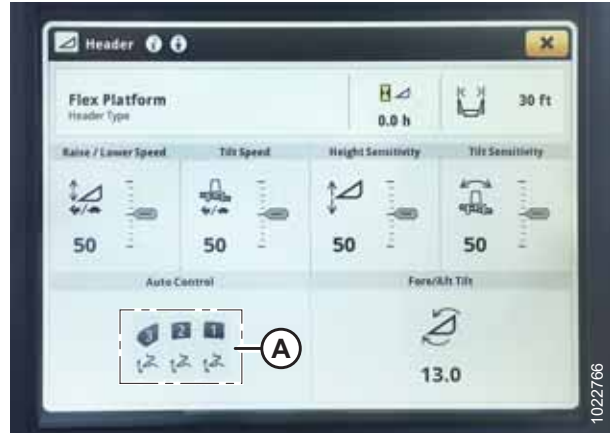

Figure 7.335: John Deere S7 Display – Header Page

11. If the header has not been calibrated yet, an error icon will appear on HEIGHT SENSING button (A). Select button (A) to view error message.



Figure 7.336: John Deere S7 Display – Auto Header Controls

12. Read error message and then press OK.
13. Proceed to *Checking Voltage Range from the Combine Cab – John Deere S7 Series, page 331.*

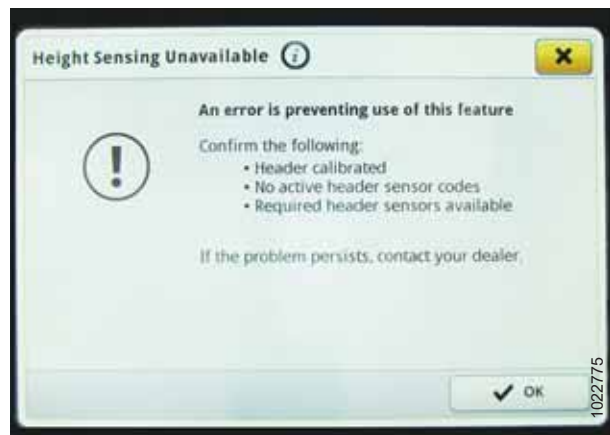

Figure 7.337: John Deere S7 Display – Height Sensing Error Message

## SETTING UP AUTO HEADER HEIGHT CONTROL

### Checking Voltage Range from the Combine Cab – John Deere S7 Series

The auto header height sensor output must be within a specific range, or the feature will not work properly.

**Table 7.3 Voltage Range**

Combine	Low Voltage Limit	High Voltage Limit	Minimum Range
John Deere S7 Series	0.5 V	4.5 V	3.0 V

**NOTE:**

Changes may have been made to the combine controls or display since this document was published. Refer to the combine operator's manual for updates.

**WARNING**

Check to be sure all bystanders have cleared the area.

1. Position the header 150 mm (6 in.) off the ground.
2. Unlock the float module float.
3. Check that float lock linkage is on down stops (washer [A] cannot be moved) at both locations.

**NOTE:**

If header is not on down stops during next two steps, voltage may go out of range during operation causing a malfunction of auto header height control (AHHC) system.

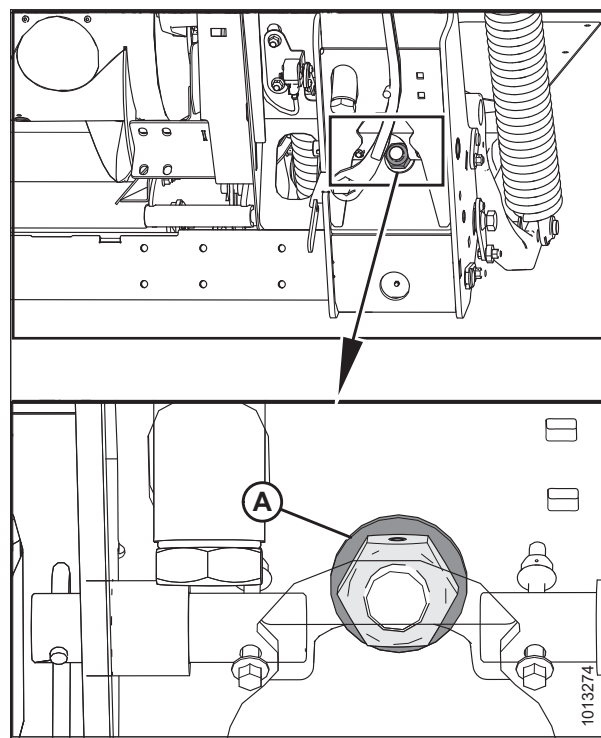

**Figure 7.338: Float Lock**

## SETTING UP AUTO HEADER HEIGHT CONTROL

- Adjust cable take-up bracket (B) (if necessary) until pointer (A) on float indicator is on 0.

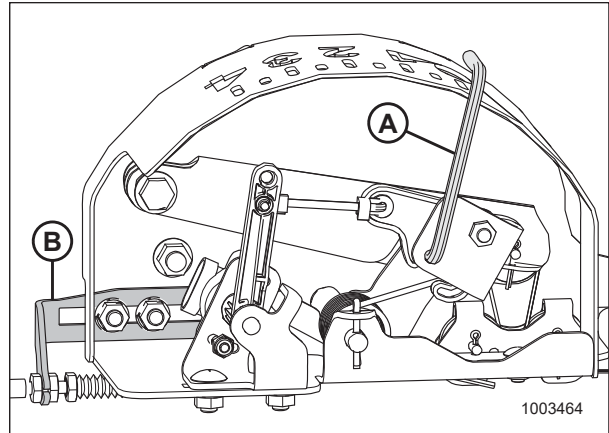

Figure 7.339: Float Indicator Box

- On the HARVESTING page, select MENU icon (A) in the bottom right corner of the screen.



Figure 7.340: John Deere S7 Display – Harvesting Page

- On the MENU page, select SYSTEM tab (A). The MENU opens.
- Select DIAGNOSTICS CENTER icon (B). The DIAGNOSTICS CENTER page opens.

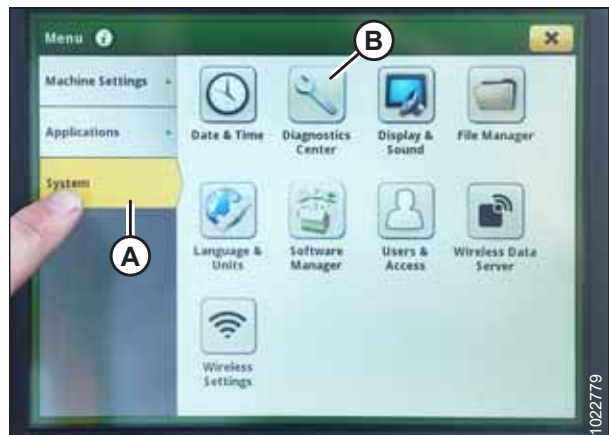

Figure 7.341: John Deere S7 Display – Menu



## SETTING UP AUTO HEADER HEIGHT CONTROL

8. Select AHC - SENSING (A). The AHC - SENSING\DIAGNOSTICS page displays.

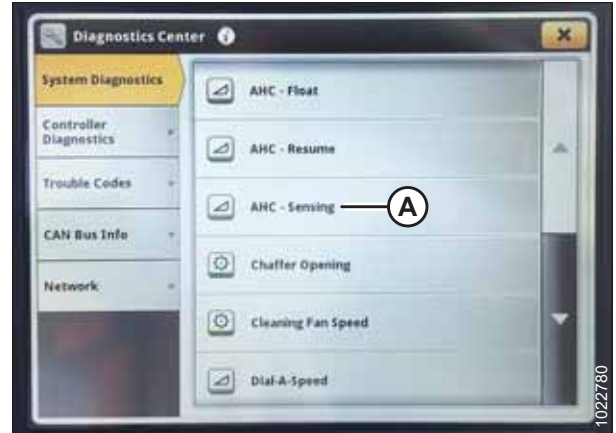

Figure 7.342: John Deere S7 Display – Diagnostics Center

9. Select SENSOR tab (A) to view sensor voltages. Center header height sensor voltage (B) must be between 0.5 and 4.5 V, with at least 3 V of variation between 0 and 4 on the float indicator box.

**NOTE:**

If the optional Auto Lateral Tilt AHHC kit is installed, the left and right header height sensors must also be in the same 0.5–4.5 V range.

10. If sensor voltage adjustment is required, refer to [Adjusting Voltage Limits – One-Sensor System, page 194](#).

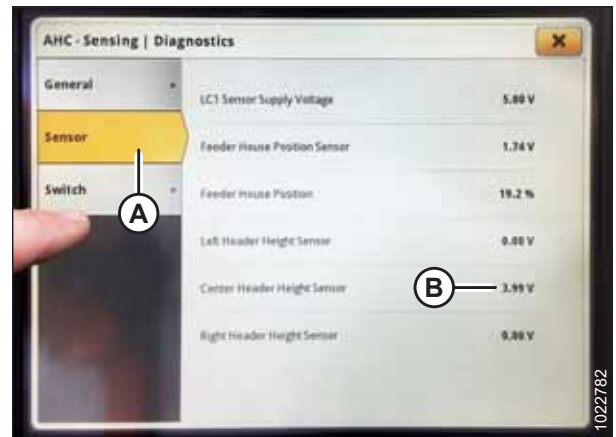

Figure 7.343: John Deere S7 Display – Checking Sensor Voltage

### Calibrating Feeder House – John Deere S7 Series

Feeder house calibration must be done before header calibration.

For best performance of auto header height control (AHHC), perform these procedures with center-link set to **D**. When setup and calibration are complete, adjust center-link back to desired header angle. For instructions, refer to the header operator's manual.

**NOTE:**

Changes may have been made to the combine controls or display since this document was published. Refer to the combine operator's manual for updates.

1. Ensure center-link is set to **D**.
2. Rest header on down stops and unlock float.
3. Place wings in locked position.

## SETTING UP AUTO HEADER HEIGHT CONTROL

- On the HARVESTING page, select MENU icon (A) in the bottom right corner of screen. The MENU opens.



Figure 7.344: John Deere S7 Display – Harvesting Page

- Select MACHINE SETTINGS tab (A).
- Select CALIBRATIONS & PROCEDURES icon (B). The CALIBRATIONS & PROCEDURES page displays.

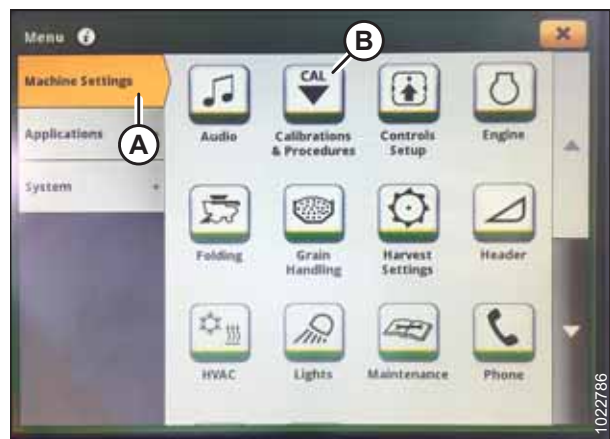

Figure 7.345: John Deere S7 Display – Machine Settings

- Select HEADER tab (A).
- Select FEEDER HOUSE RAISE SPEED CALIBRATION (B). The FH RAISE SPEED CALIBRATION page displays.

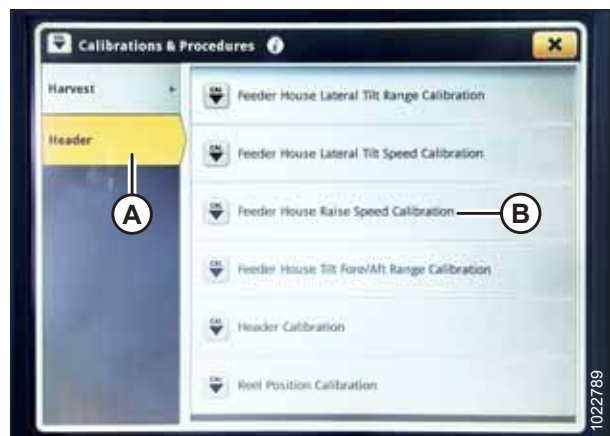

Figure 7.346: John Deere S7 Display – Calibrations and Procedures

## SETTING UP AUTO HEADER HEIGHT CONTROL

9. Select CALIBRATE (A) at the bottom of the page. A calibration overview displays.

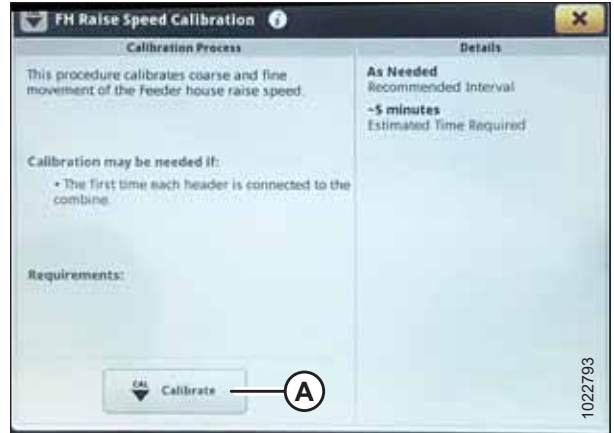

Figure 7.347: John Deere S7 Display – Feeder House Calibration

10. Read the calibration overview, and then press START.



Figure 7.348: John Deere S7 Display – Feeder House Calibration

11. Follow the instructions on the screen. As you proceed through the calibration process, the display will automatically update to show next step.



Figure 7.349: John Deere S7 Display – Feeder House Calibration

## SETTING UP AUTO HEADER HEIGHT CONTROL

- When calibration is complete, select SAVE to confirm calibration.



Figure 7.350: John Deere S7 Display – Feeder House Calibration

### Calibrating Header – John Deere S7 Series

#### **WARNING**

Never start or move the machine until you are sure all bystanders have cleared the area.

Feeder house calibration must be done before header calibration. If feeder house has not yet been calibrated, refer to [Calibrating Feeder House – John Deere S7 Series, page 333](#).

For best performance of auto header height control (AHHC), perform these procedures with the center-link set to **D**. When setup and calibration are complete, adjust center-link back to desired header angle. For instructions, refer to Header Angle in the header operator's manual.

#### **NOTE:**

Changes may have been made to combine controls or display since this document was published. Refer to the combine operator's manual for updates.

- Ensure center-link is set to **D**.
- Rest header on down stops and unlock float.
- Place wings in locked position.
- On the HARVESTING page, select MENU icon (A) in the bottom right corner of screen. The MENU opens.



Figure 7.351: John Deere S7 Display – Harvesting Page

## SETTING UP AUTO HEADER HEIGHT CONTROL

5. Select MACHINE SETTINGS tab (A).
6. Select CALIBRATIONS & PROCEDURES icon (B). The CALIBRATIONS & PROCEDURES page displays.



Figure 7.352: John Deere S7 Display – Machine Settings

7. Select HEADER tab (A).
8. Select HEADER CALIBRATION (B). The HEADER CALIBRATION page displays.

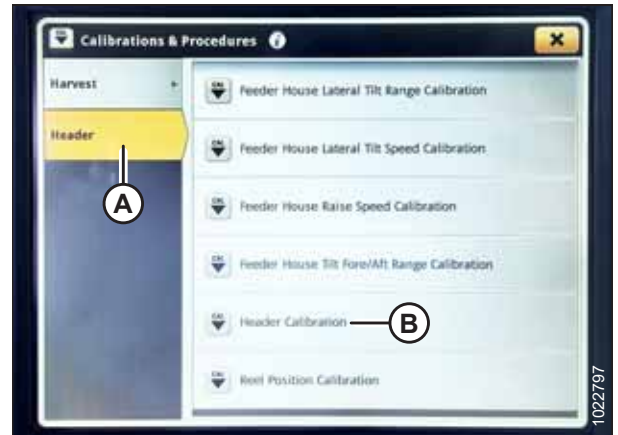

Figure 7.353: John Deere S7 Display – Calibrations and Procedures

9. Select CALIBRATE (A) at bottom of page. The calibration overview window opens.

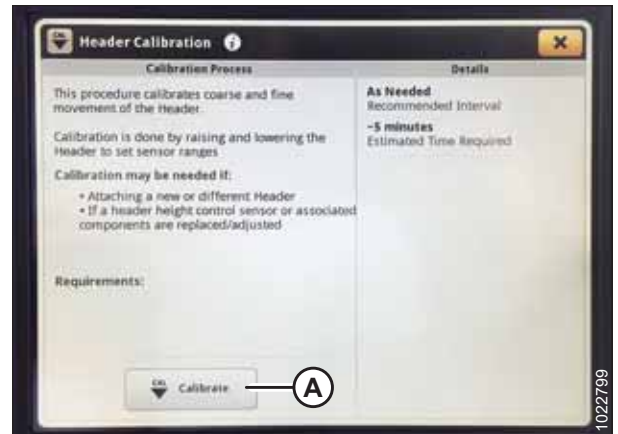

Figure 7.354: John Deere S7 Display – Header Calibration

## SETTING UP AUTO HEADER HEIGHT CONTROL

10. Press button (A) on console to set engine to high idle.



Figure 7.355: John Deere S7 Console

11. Select START on calibration overview page.
12. Follow instructions that appear on combine display. As you proceed through calibration process, display will automatically update to show next step.

### NOTE:

If an error code appears during calibration, sensor is out of voltage range and will require adjustment. For instructions, refer to [Adjusting Voltage Limits – One-Sensor System, page 194](#).



Figure 7.356: John Deere S7 Display – Header Calibration

13. When calibration is complete, select SAVE to confirm calibration.



Figure 7.357: John Deere S7 Display – Header Calibration

### 7.1.18 New Holland Combines – CR/CX Series – 2014 and Prior

This section applies only to pre-2015 CR/CX models. For New Holland CR models 6.80, 6.90, 7.90, 8.90, 9.90, and 10.90, refer to [7.1.19 New Holland Combines – CR Series – 2015 and Later, page 349](#).

#### Checking Voltage Range from the Combine Cab – New Holland CR/CX Series

**NOTE:**

Changes may have been made to the combine controls or display since this document was published. Refer to the combine operator’s manual for updates.

**NOTE:**

For New Holland CR models 6.80, 6.90, 7.90, 8.90, 9.90, and 10.90, refer to [7.1.19 New Holland Combines – CR Series – 2015 and Later, page 349](#).

 **WARNING**

Check to be sure all bystanders have cleared the area.

1. Position the header 150 mm (6 in.) above the ground, and unlock the float.
2. Check that float lock linkage is on down stops (washer [A] cannot be moved) at both locations.

**NOTE:**

If the header is not on down stops during the next two steps, the voltage may go out of range during operation causing a malfunction of the AHHC system.

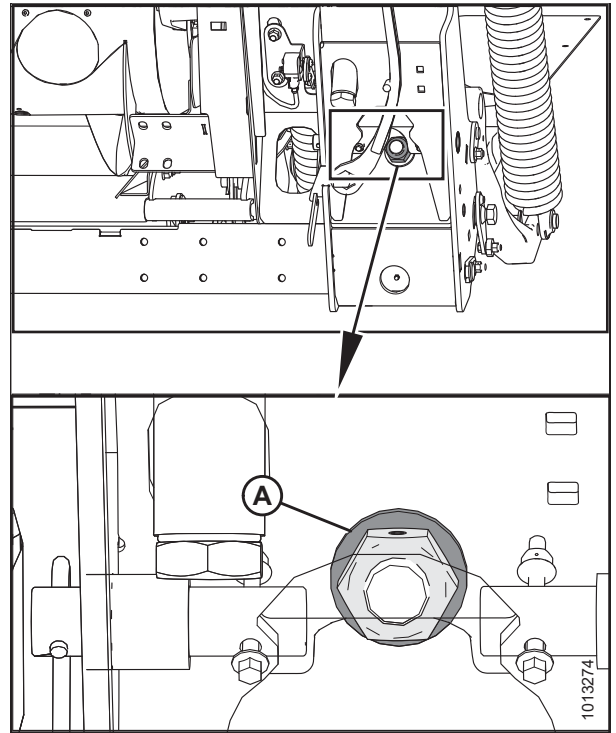

Figure 7.358: Float Lock

## SETTING UP AUTO HEADER HEIGHT CONTROL

- Adjust cable take-up bracket (B) (if necessary) until float indicator pointer (A) is on 0.

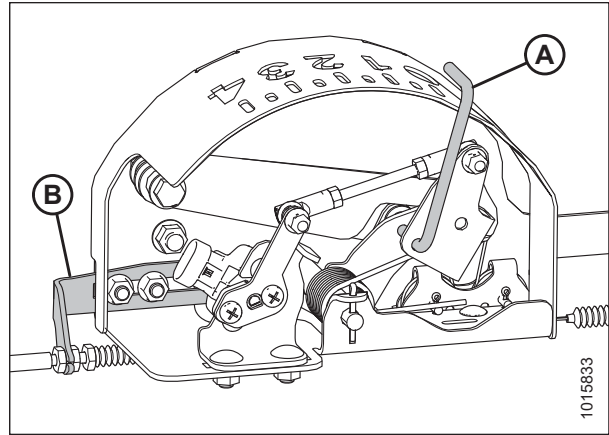

Figure 7.359: Float Indicator Box

- Ensure header float is unlocked.
- Select DIAGNOSTICS (A) on the main screen. The DIAGNOSTICS screen displays.
- Select SETTINGS. The SETTINGS screen displays.

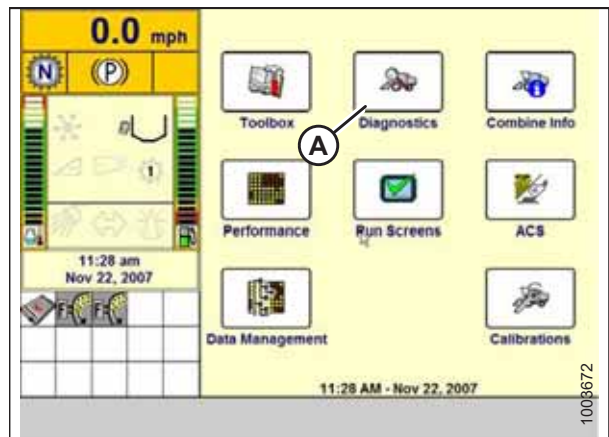

Figure 7.360: New Holland Combine Display

- Select GROUP drop-down arrow (A). The GROUP dialog box displays.

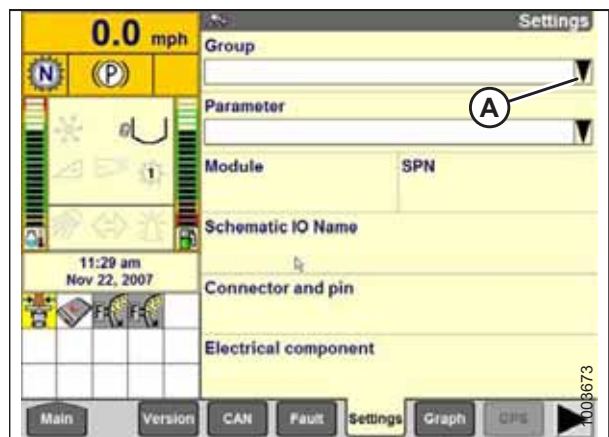

Figure 7.361: New Holland Combine Display



## SETTING UP AUTO HEADER HEIGHT CONTROL

8. Select HEADER HEIGHT/TILT (A). The PARAMETER screen displays.

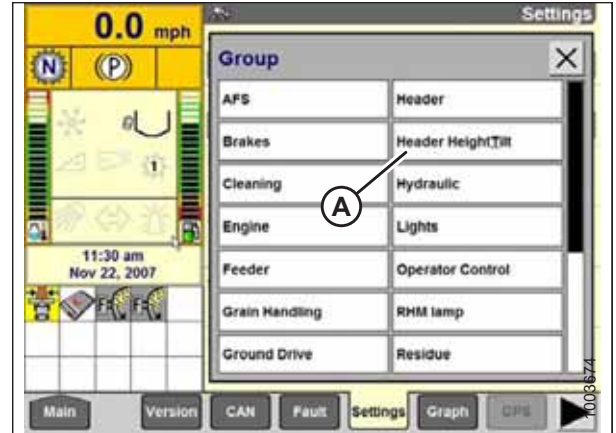

Figure 7.362: New Holland Combine Display

9. Select LEFT HEADER HEIGHT SEN (A), and then select GRAPH button (B). The exact voltage is displayed at the top of the screen.
10. Raise and lower the header to see the full range of voltage readings.
11. If the sensor voltage is not within the low and high limits, or if the range between the low and high limits is insufficient, adjust the voltage limits. For instructions, refer to [Adjusting Voltage Limits – One-Sensor System, page 194](#).

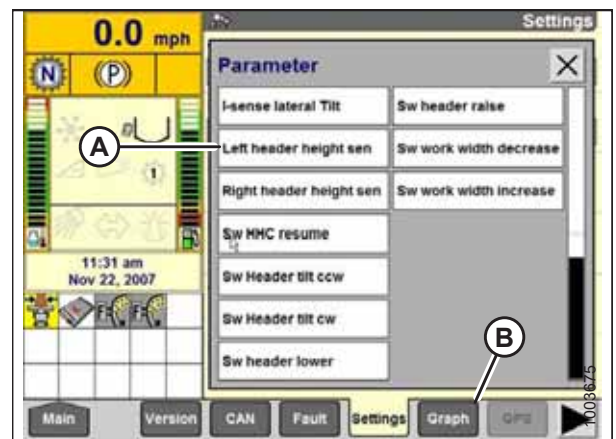

Figure 7.363: New Holland Combine Display

### Setting up Auto Header Height Control – New Holland CR/CX Series

**NOTE:**

Changes may have been made to the combine controls or display since this document was published. Refer to the combine operator's manual for updates.

**NOTE:**

For New Holland CR models 6.80, 6.90, 7.90, 8.90, 9.90, and 10.90, refer to [7.1.19 New Holland Combines – CR Series – 2015 and Later, page 349](#).

## SETTING UP AUTO HEADER HEIGHT CONTROL

1. Select HEADER LATERAL FLOAT on the combine display, and press ENTER.
2. Use the up and down navigation keys to move between options, and select INSTALLED.



Figure 7.364: New Holland Combine Display

3. Select HEADER AUTOFLOAT, and press ENTER.
4. Use the up and down navigation keys to move between options, and select INSTALLED.



Figure 7.365: New Holland Combine Display

### Calibrating the Auto Header Height Control – New Holland CR/CX Series

For best performance of the auto header height control (AHHC), perform these procedures with the center-link set to **D**. When setup and calibration are complete, adjust the center-link back to desired header angle. For instructions, refer to the header operator's manual.

#### NOTE:

Changes may have been made to the combine controls or display since this document was published. Refer to the combine operator's manual for updates.

#### NOTE:

For New Holland CR models 6.80, 6.90, 7.90, 8.90, 9.90, and 10.90, refer to [7.1.19 New Holland Combines – CR Series – 2015 and Later, page 349](#).

### WARNING

Check to be sure all bystanders have cleared the area.

#### NOTE:

If header float is set too light, it can prevent calibration of AHHC. You may need to set the float heavier for calibration procedure so header doesn't separate from the float module.

## SETTING UP AUTO HEADER HEIGHT CONTROL

Check the following conditions before starting the header calibration procedure:

- The header is attached to the combine.
- The combine is on level ground, with the header level to the ground.
- The header is on down stops, and the center-link is set to **D**.
- The engine is running.
- The combine is not moving.
- No faults have been received from the Header Height Controller (HHC) module.
- Header/feeder is disengaged.
- Lateral float buttons are **NOT** pressed.
- ESC key is **NOT** pressed.

**To calibrate the AHHC, follow these steps:**

1. Select CALIBRATION on the combine display, and press the RIGHT ARROW navigation key to enter the information box.
2. Select HEADER (A), and press ENTER. The CALIBRATION dialog box opens.

**NOTE:**

You can use the up and down navigation keys to move between options.



Figure 7.366: New Holland Combine Display

3. Follow the calibration steps in the order in which they appear in the dialog box. As you proceed through the calibration process, the display will automatically update to show the next step.

**NOTE:**

Pressing the ESC key during any of the steps or letting the system sit idle for more than 3 minutes will cause the calibration procedure to stop.

**NOTE:**

Refer to your combine operator's manual for an explanation of any error codes.



Figure 7.367: New Holland Combine Display

4. When all steps have been completed, CALIBRATION SUCCESSFUL message is displayed on the screen. Exit the CALIBRATION menu by pressing the ENTER or ESC key.

## SETTING UP AUTO HEADER HEIGHT CONTROL

**NOTE:**

If float was set heavier to complete AHHC calibration procedure, adjust to recommended operating float after the calibration is complete.

5. If the unit does not function properly, conduct the maximum stubble height calibration.

## SETTING UP AUTO HEADER HEIGHT CONTROL

### *Calibrating Maximum Stubble Height – New Holland CR/CX Series*

This procedure describes how to calibrate the area counter to stop or start counting at the correct height. Program the header to a height that will never be reached while cutting. The area counter will stop counting when the header is above the programmed height, and will begin counting when the header is below the programmed height.

Select the height of the header that corresponds to the description above.

#### **IMPORTANT:**

- If the value is set too low, area may **NOT** be counted since the header is sometimes raised above this threshold although the combine is still cutting.
- If the value is set too high, the area counter will keep counting even when the header is raised (but below this threshold) and the combine is no longer cutting crop.

#### **WARNING**

Check to be sure all bystanders have cleared the area.

1. Select the MAXIMUM STUBBLE HEIGHT calibration dialog box. As you proceed through the calibration process, the display will automatically update to show the next step.

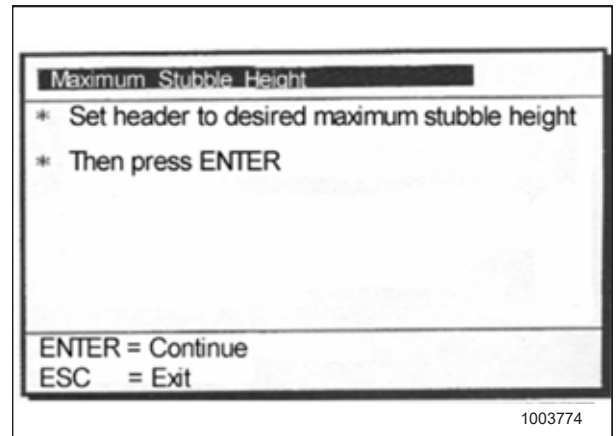

Figure 7.368: New Holland Calibration Dialog Box

2. Move header to the correct position using the header up or down control switch on the multifunction handle.
3. Press ENTER to continue. As you proceed through the calibration process, the display will automatically update to show the next step.
4. Press ENTER or ESC to close the calibration screen. The calibration is now complete.

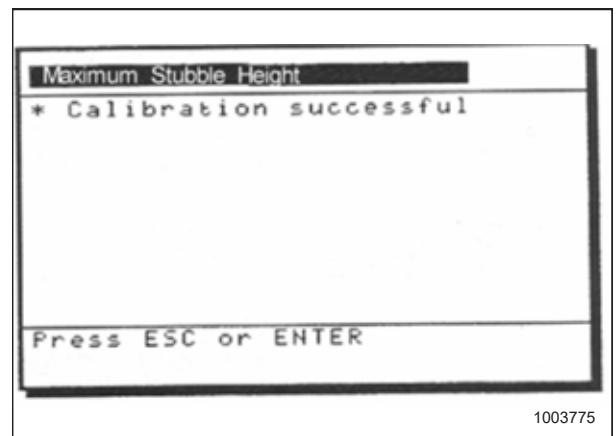

Figure 7.369: New Holland Calibration Dialog Box

## SETTING UP AUTO HEADER HEIGHT CONTROL

### *Adjusting Header Raise Rate – New Holland CR/CX Series*

If necessary, the header raise rate (the first speed on the HEADER HEIGHT rocker switch of the multifunctional handle) can be adjusted.

**NOTE:**

Changes may have been made to the combine controls or display since this document was published. Refer to the combine operator's manual for updates.

**NOTE:**

For New Holland CR models 6.80, 6.90, 7.90, 8.90, 9.90, and 10.90, refer to [7.1.19 New Holland Combines – CR Series – 2015 and Later, page 349](#).

1. Select HEADER RAISE RATE on the combine display.
2. Use the + or – buttons to change the setting.
3. Press ENTER to save the new setting.

**NOTE:**

The raise rate can be changed from 32–236 in increments of 34. The factory setting is 100.

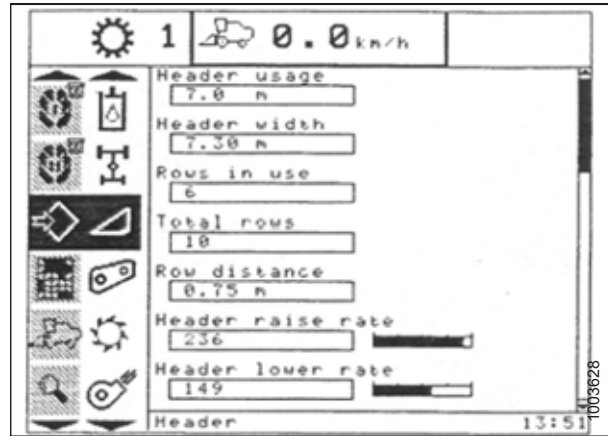

Figure 7.370: New Holland Combine Display

## SETTING UP AUTO HEADER HEIGHT CONTROL

### *Setting the Header Lower Rate – New Holland CR/CX Series*

If necessary, the header lower rate (the automatic header height control button or second speed on the header height rocker switch of the multifunction handle) can be adjusted.

**NOTE:**

Changes may have been made to the combine controls or display since this document was published. Refer to the combine operator's manual for updates.

**NOTE:**

For New Holland CR models 6.80, 6.90, 7.90, 8.90, 9.90, and 10.90, refer to [7.1.19 New Holland Combines – CR Series – 2015 and Later, page 349](#).

1. Select HEADER LOWER RATE on the combine display.
2. Use the + or – buttons to change the setting to 50.
3. Press ENTER to save the new setting.

**NOTE:**

The header lower rate can be changed from 2–247 in increments of 7. It is factory-set to 100.

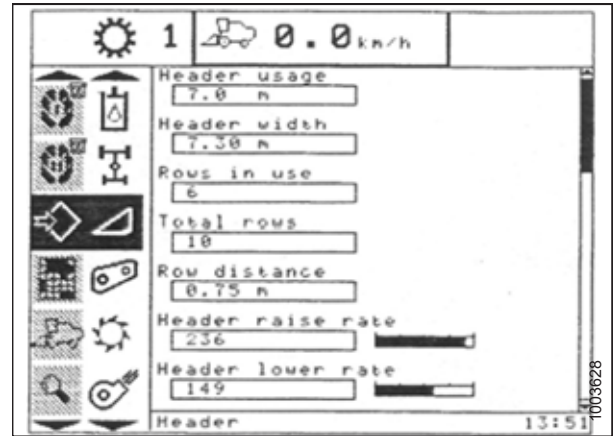

Figure 7.371: New Holland Combine Display

### *Setting the Sensitivity of the Auto Header Height Control – New Holland CR/CX Series*

The sensitivity adjustment controls the distance the cutterbar must travel up or down before the auto header height control (AHHC) reacts and raises or lowers the feeder house.

When the sensitivity is set to maximum, only small changes in ground height are needed to cause the feeder house to raise or lower. When the sensitivity is set to minimum, large changes in the ground height are needed to cause the feeder house to raise or lower.

**NOTE:**

Changes may have been made to the combine controls or display since this document was published. Refer to the combine operator's manual for updates.

**NOTE:**

For New Holland CR models 6.80, 6.90, 7.90, 8.90, 9.90, and 10.90, refer to [7.1.19 New Holland Combines – CR Series – 2015 and Later, page 349](#).



## **WARNING**

Check to be sure all bystanders have cleared the area.

## SETTING UP AUTO HEADER HEIGHT CONTROL

1. Engage threshing and feeder house.
2. Select HEIGHT SENSITIVITY on the combine display screen.
3. Use the + or – buttons to change the setting to 200.
4. Press ENTER to save the new setting.

**NOTE:**

The sensitivity can be changed from 10–250 in increments of 10. It is factory-set to 100.



Figure 7.372: New Holland Combine Display

### Setting Preset Cutting Height – New Holland CR/CX Series

To set the preset cutting height, follow these steps:

**NOTE:**

Changes may have been made to the combine controls or display since this document was published. Refer to the combine operator's manual for updates.

**NOTE:**

For New Holland CR models 6.80, 6.90, 7.90, 8.90, 9.90, and 10.90, refer to [7.1.19 New Holland Combines – CR Series – 2015 and Later, page 349](#).

**NOTE:**

Indicator (A) should be at position 0 (B) with the header (152 mm [6 in.]) off the ground. If not, the float sensor output voltage should be checked. Refer to [Step 5, page 190](#). When the header is on the ground, the indicator should be at position 1 (C) for low ground pressure, and at position 4 (D) for high ground pressure. Crop and soil conditions determine the amount of float to use. The ideal setting is as light as possible without header bouncing or missing crop. Operating with heavy settings prematurely wears the cutterbar wearplates.

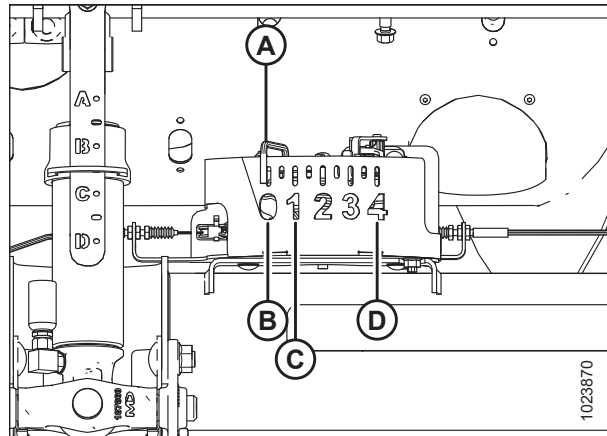

Figure 7.373: Float Indicator Box



## SETTING UP AUTO HEADER HEIGHT CONTROL

1. Engage the threshing mechanism and the feeder with switches (A) and (B).
2. Set HEADER MEMORY rocker switch (D) in STUBBLE HEIGHT/AUTOFLOAT mode position (A) or (B).
3. Raise or lower the header to the desired cutting height using HEADER HEIGHT and HEADER LATERAL FLOAT momentary switch (C).
4. Lightly press AUTOMATIC HEADER HEIGHT CONTROL button (E) for a minimum of 2 seconds to store the height position. A beep will confirm the setting.

**NOTE:**

It is possible to store two different header height values by using HEADER MEMORY rocker switch (D) in STUBBLE HEIGHT/AUTOFLOAT mode position (A) or (B).

5. Raise or lower the reel to the desired working height using REEL HEIGHT momentary switch (E).
6. Lightly press AUTOMATIC HEADER HEIGHT CONTROL button (E) for a minimum of 2 seconds to store the height position. A beep will confirm the setting.
7. To change one of the memorized header height set points while the combine is in use, use HEADER HEIGHT AND HEADER LATERAL FLOAT rocker switch (A) (slow up/down) to raise or lower header to the desired value. Lightly press AUTOMATIC HEADER HEIGHT CONTROL button (B) for a minimum of 2 seconds to store the new height position. A beep will confirm setting.

**NOTE:**

Fully pressing AUTOMATIC HEADER HEIGHT CONTROL button (B) will disengage float mode.

**NOTE:**

It is not necessary to press rocker switch (C) again after changing header height set point.

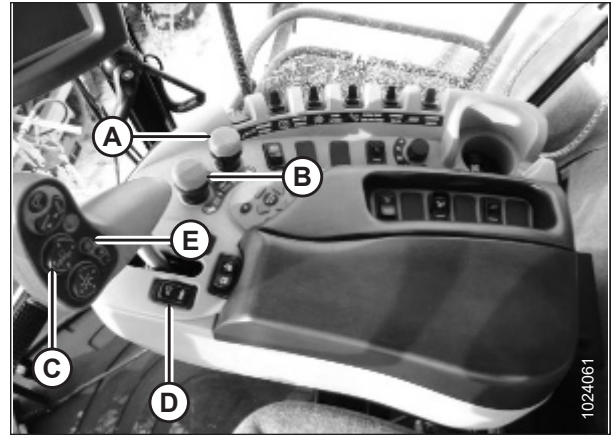

Figure 7.374: New Holland Combine Controls

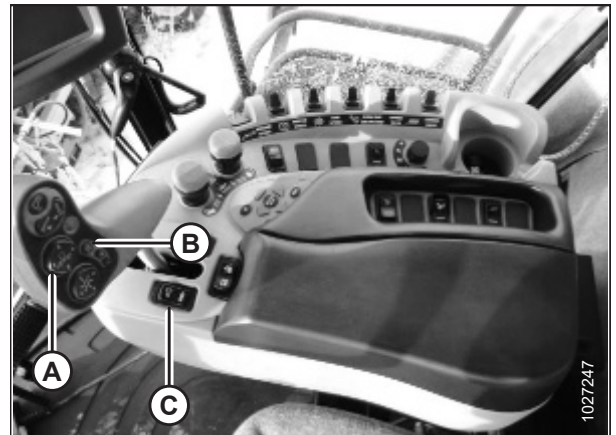

Figure 7.375: New Holland Combine Controls

### 7.1.19 New Holland Combines – CR Series – 2015 and Later

This section applies only to 2015 and later CR models (6.80, 6.90, 7.90, 8.90, 9.90, and 10.90). For other pre-2015 New Holland combine models, refer to [7.1.18 New Holland Combines – CR/CX Series – 2014 and Prior, page 339](#).

#### *Checking Voltage Range from the Combine Cab – New Holland CR Series*

**NOTE:**

Changes may have been made to the combine controls or display since this document was published. Refer to the combine operator's manual for updates.

**NOTE:**

This section applies only to 2015 and later CR models (6.80, 6.90, 7.90, 8.90, 9.90, and 10.90). For other pre-2015 New Holland combine models, refer to [7.1.18 New Holland Combines – CR/CX Series – 2014 and Prior, page 339](#).

## SETTING UP AUTO HEADER HEIGHT CONTROL

### **WARNING**

Check to be sure all bystanders have cleared the area.

1. Position the header 150 mm (6 in.) above the ground, and unlock the float.
2. Check that float lock linkage is on down stops (washer [A] cannot be moved) at both locations.

#### **NOTE:**

If the header is not on down stops during the next two steps, the voltage may go out of range during operation causing a malfunction of the auto header height control (AHHC) system.

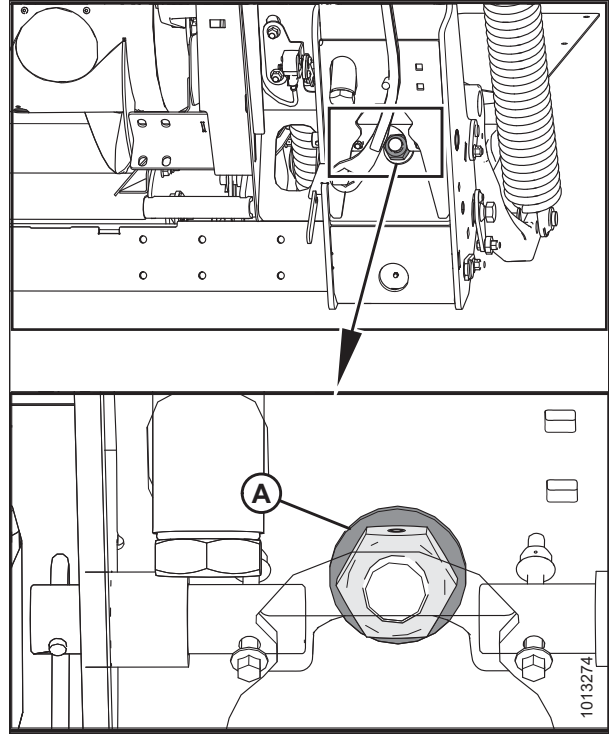

Figure 7.376: Float Lock

3. Adjust cable take-up bracket (B) (if necessary) until float indicator pointer (A) is on 0.
4. Ensure header float is unlocked.

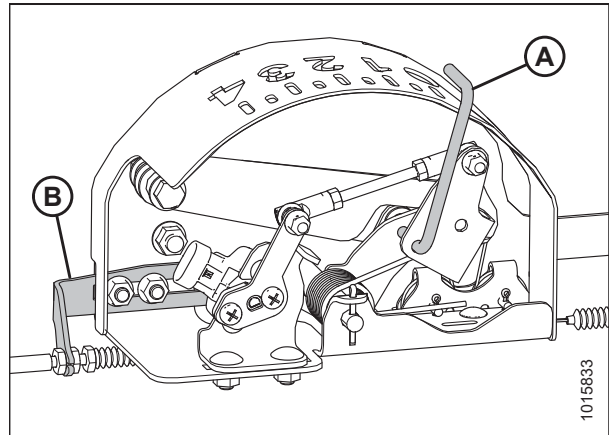

Figure 7.377: Float Indicator Box

## SETTING UP AUTO HEADER HEIGHT CONTROL

5. Select DIAGNOSTICS (A) on the main screen. The DIAGNOSTICS screen displays.



Figure 7.378: New Holland Combine Display

6. Select SETTINGS (A). The SETTINGS screen displays.



Figure 7.379: New Holland Combine Display

7. Select HEADER HEIGHT/TILT (A) from the GROUP drop-down menu.
8. Select HEADER HEIGHT SENS. L (B) from the PARAMETER drop-down menu.



Figure 7.380: New Holland Combine Display

## SETTING UP AUTO HEADER HEIGHT CONTROL

9. Select GRAPH (A). The exact voltage (B) is displayed at the top of the screen.
10. Raise and lower the header to see the full range of voltage readings.
11. If the sensor voltage is not within the low and high limits, or if the range between the low and high limits is insufficient, adjust the voltage limits. For instructions, refer to *Adjusting Voltage Limits – One-Sensor System, page 194*.

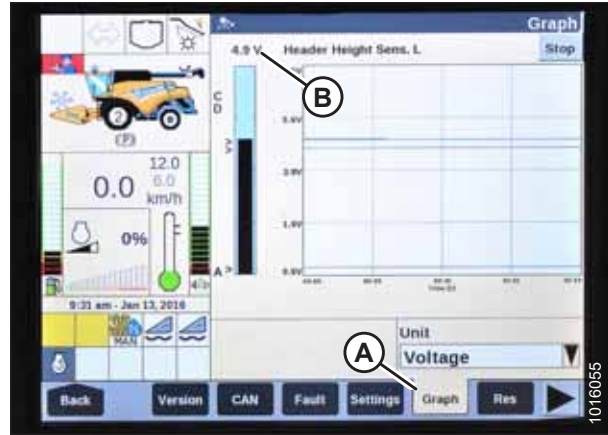

Figure 7.381: New Holland Combine Display

### Setting up Auto Header Height Control – New Holland CR Series

For best performance of the auto header height control (AHHC), perform these procedures with the center-link set to **D**. When setup and calibration are complete, adjust the center-link back to desired header angle.

#### NOTE:

Changes may have been made to the combine controls or display since this document was published. Refer to the combine operator's manual for updates.

#### NOTE:

This section applies only to 2015 and later CR models (6.80, 6.90, 7.90, 8.90, 9.90, and 10.90). For other pre-2015 New Holland combine models, refer to *7.1.18 New Holland Combines – CR/CX Series – 2014 and Prior, page 339*.

1. Ensure center-link is set to **D**.
2. Select TOOLBOX (A) on the main screen. The TOOLBOX screen displays.



Figure 7.382: New Holland Combine Display

## SETTING UP AUTO HEADER HEIGHT CONTROL

3. Simultaneously press UNLOAD (A) and RESUME (B) buttons on the control handle.

**NOTE:**

Software in some New Holland combines may not allow you to change the header from FLEX to PLATFORM or the header type from DEFAULT to 80/90 at the main menu. This is now a dealer setting, and requires you to access the DEALER SETTING screen by pressing and holding both the UNLOAD and RESUME buttons on the control handle for approximately 10 seconds. The DEALER SETTING screen should appear and will allow you to change the header and header type settings.



Figure 7.383: New Holland Combine Controls

4. Select HEAD 1 (A). The HEADER SETUP 1 screen displays.
5. Select CUTTING TYPE drop-down arrow (B) and change the CUTTING TYPE to PLATFORM (C).



Figure 7.384: New Holland Combine Display

6. Select HEADER SUB TYPE drop-down arrow (A). The HEADER SUB TYPE dialog box displays.



Figure 7.385: New Holland Combine Display

## SETTING UP AUTO HEADER HEIGHT CONTROL

- Set HEADER SUB TYPE to 80/90 (A) for a New Holland combine.



Figure 7.386: New Holland Combine Display

- Select HEAD 2 (A). The HEADER SETUP 2 screen displays.



Figure 7.387: New Holland Combine Display

- Select the AUTOFLOAT drop-down arrow and set AUTOFLOAT to INSTALLED (A).
- Select the AUTO HEADER LIFT drop-down arrow and set AUTO HEADER LIFT to INSTALLED (B).

**NOTE:**

With AUTO HEADER LIFT installed and AHHC engaged, the header will lift up automatically when you pull back on the control handle.

- Set the values for MANUAL HHC RAISE RATE (C) and MANUAL HHC LOWER RATE (D) for best performance according to ground conditions.



Figure 7.388: New Holland Combine Display

## SETTING UP AUTO HEADER HEIGHT CONTROL

- Set the values for HHC HEIGHT SENSITIVITY (A) and HHC TILT SENSITIVITY (B) for best performance according to ground conditions.



Figure 7.389: New Holland Combine Display

- From REEL HEIGHT SENSOR menu (A), select YES.



Figure 7.390: New Holland Combine Display

### Calibrating the Auto Header Height Control – New Holland CR Series

For best performance of the auto header height control (AHHC), perform these procedures with the center-link set to D. When setup and calibration are complete, adjust the center-link back to desired header angle. For instructions, refer to the header operator's manual.

#### NOTE:

Changes may have been made to the combine controls or display since this document was published. Refer to the combine operator's manual for updates.

#### NOTE:

This section applies only to 2015 and later CR models (6.80, 6.90, 7.90, 8.90, 9.90, and 10.90). For other pre-2015 New Holland combine models, refer to [7.1.18 New Holland Combines – CR/CX Series – 2014 and Prior, page 339](#).



### WARNING

Check to be sure all bystanders have cleared the area.

#### NOTE:

If header float is set too light, it can prevent calibration of AHHC. You may need to set the float heavier for calibration procedure so header doesn't separate from the float module.

Check the following conditions before starting the header calibration procedure:

## SETTING UP AUTO HEADER HEIGHT CONTROL

- The header is attached to the combine.
- The combine is on level ground, with the header level to the ground.
- The header is on down stops, and the center-link is set to **D**.
- The engine is running.
- The combine is not moving.
- No faults have been received from the header height controller (HHC) module.
- Header/feeder is disengaged.
- Lateral float buttons are **NOT** pressed.
- ESC key is **NOT** pressed.

To calibrate the AHHC, follow these steps:

1. Select CALIBRATIONS (A) on the main screen. The CALIBRATION screen displays.

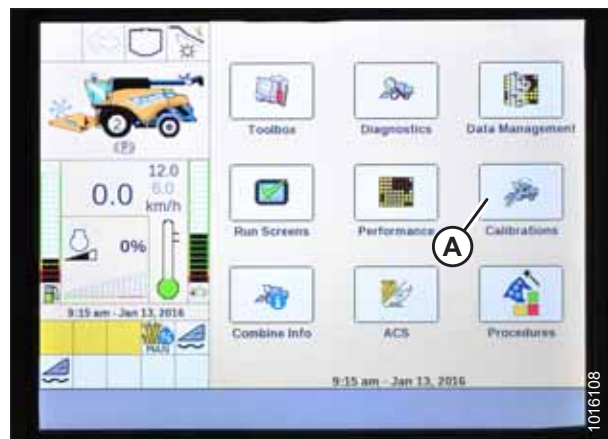

Figure 7.391: New Holland Combine Display

2. Select CALIBRATION drop-down arrow (A).



Figure 7.392: New Holland Combine Display



## SETTING UP AUTO HEADER HEIGHT CONTROL

3. Select HEADER (A) from the list of calibration options.



Figure 7.393: New Holland Combine Display

4. Follow the calibration steps in the order in which they appear on the screen. As you proceed through the calibration process, the display will automatically update to show the next step.

**NOTE:**

Pressing the ESC key during any of the steps or letting the system sit idle for more than 3 minutes will cause the calibration procedure to stop.

**NOTE:**

Refer to your combine operator's manual for an explanation of any error codes.



Figure 7.394: New Holland Combine Display

5. When all steps have been completed, CALIBRATION COMPLETED message is displayed on the screen.

**NOTE:**

If float was set heavier to complete AHHC calibration procedure, adjust to recommended operating float after the calibration is complete.



Figure 7.395: New Holland Combine Display

## SETTING UP AUTO HEADER HEIGHT CONTROL

### Checking Reel Height Sensor Voltages – New Holland CR Series

**NOTE:**

Changes may have been made to the combine controls or display since this document was published. Refer to the combine operator's manual for updates.

1. On the main page of the combine display, select DIAGNOSTICS (A). The DIAGNOSTICS page opens.



Figure 7.396: New Holland Combine Display

2. Select SETTINGS tab (A). The SETTINGS page opens.
3. From GROUP menu (B), select HEADER.
4. From PARAMETER menu (C), select REEL VERTICAL POSITION.

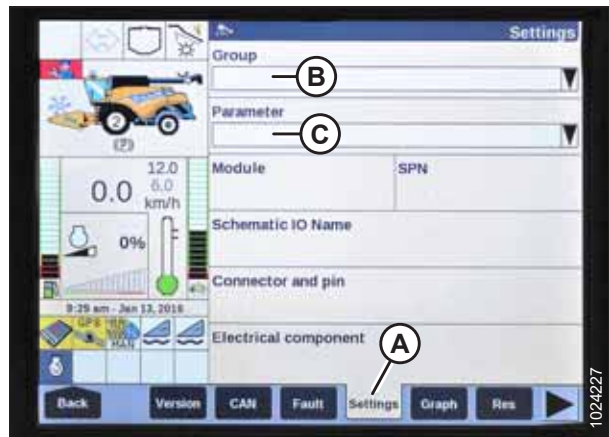

Figure 7.397: New Holland Combine Display

5. Select GRAPH tab (A). The REEL VERTICAL POSITION graph displays.
6. Lower the reel to view high voltage (B). The voltage should be 4.1–4.5 V.
7. Raise the reel to view low voltage (C). The voltage should be 0.5–0.9 V.
8. If either voltage is out of range, refer to [8.1 Checking and Adjusting Reel Height Sensor](#), page 365.

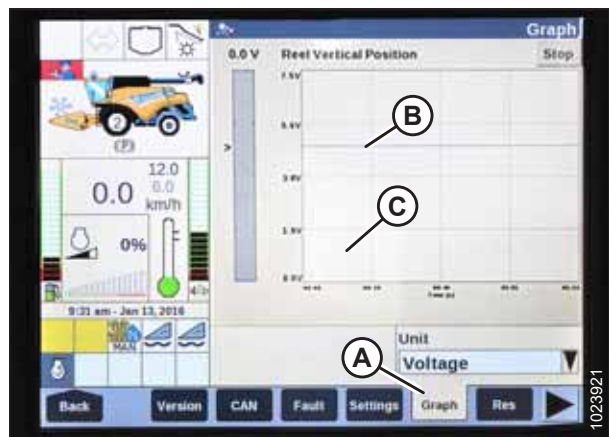

Figure 7.398: New Holland Combine Display

## SETTING UP AUTO HEADER HEIGHT CONTROL

### Setting Preset Cutting Height – New Holland CR Series

#### NOTE:

This section applies only to 2015 and later CR models (6.80, 6.90, 7.90, 8.90, 9.90, and 10.90). For other pre-2015 New Holland combine models, refer to [7.1.18 New Holland Combines – CR/CX Series – 2014 and Prior, page 339](#).

The console has two buttons used for auto height presets. The toggle switch that was present on previous models is now configured as shown at right. MacDon headers only require first two buttons (A) and (B). Third button (C) is not configured.

#### **WARNING**

Check to be sure all bystanders have cleared the area.

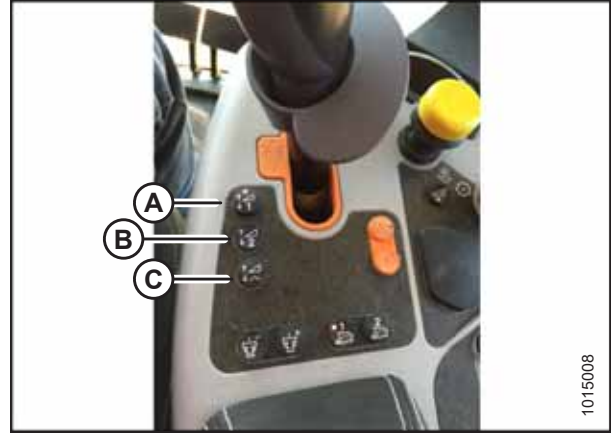

Figure 7.399: New Holland Combine Controls

#### To set preset cutting height, follow these steps:

1. Engage separator and header.
2. Select preset button 1 (A). A yellow light on the button will illuminate.
3. Raise or lower the header to the desired cutting height.



Figure 7.400: New Holland Combine Controls

4. Hold RESUME button (C) on the multifunction handle to set the preset.

#### NOTE:

When setting presets, always set header position before setting reel position. If header and reel are set at the same time, the reel setting will not save.

5. Raise or lower the reel to the desired working position.
6. Hold RESUME button (C) on multifunction handle to set the preset.
7. Repeat Step 2, [page 359](#) to Step 6, [page 359](#), using preset button 2.



Figure 7.401: New Holland Combine Multifunction Handle

## SETTING UP AUTO HEADER HEIGHT CONTROL

- Lower header to the ground.
- Select RUN SCREENS (A) on the main screen.



Figure 7.402: New Holland Combine Display

- Select the RUN tab that shows MANUAL HEIGHT.

**NOTE:**

The MANUAL HEIGHT field may appear on any of the RUN tabs. When an auto height preset button is pressed, the display will change to AUTO HEIGHT (A).

- Press one of the auto height preset buttons to select a preset cutting height.



Figure 7.403: New Holland Combine Display

## SETTING UP AUTO HEADER HEIGHT CONTROL

### Setting Maximum Work Height – New Holland CR Series

#### NOTE:

This section applies only to 2015 and later CR models (6.80, 6.90, 7.90, 8.90, 9.90, and 10.90). For other pre-2015 New Holland combine models, refer to [7.1.18 New Holland Combines – CR/CX Series – 2014 and Prior, page 339](#).

1. Select TOOLBOX (A) on the main screen. The TOOLBOX screen displays.



Figure 7.404: New Holland Combine Display

2. Select FEEDER (A). The FEEDER SETUP screen displays.
3. Select MAXIMUM WORK HEIGHT field (B).

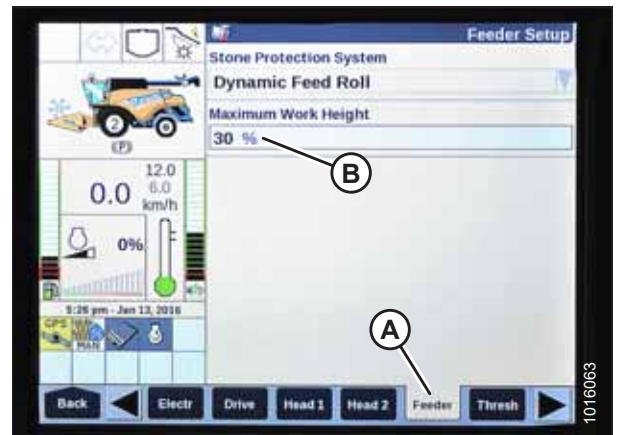

Figure 7.405: New Holland Combine Display

4. Set MAXIMUM WORK HEIGHT to desired value.
5. Press SET and then press ENTER.



Figure 7.406: New Holland Combine Display

## SETTING UP AUTO HEADER HEIGHT CONTROL

### *Configuring Reel Fore-Aft, Header Tilt, and Header Type – New Holland CR Series*

This procedure applies only to 2016 New Holland CR models 6.90, 7.90, 8.90, and 9.90.

#### **NOTE:**

Changes may have been made to the combine controls or display since this document was published. Refer to the combine operator's manual for updates.

1. Simultaneously press UNLOAD (A) and RESUME (B) buttons on the control handle.



Figure 7.407: New Holland Combine Controls

2. On the HEAD 1 screen, change the CUTTING TYPE from FLEX to PLATFORM as shown at location (A).



Figure 7.408: New Holland Combine Display

3. On the HEAD 2 screen, change HEADER SUB TYPE from DEFAULT to 80/90 as shown at location (A).



Figure 7.409: New Holland Combine Display

## SETTING UP AUTO HEADER HEIGHT CONTROL

There are now two different buttons for ON GROUND presets. The toggle switch that was present on previous models is now configured as shown at right. MacDon headers only require first two buttons (A) and (B). Third button down (C) is not configured.



Figure 7.410: New Holland Combine Controls

1015008





# Chapter 8: Setting up Reel Height Sensor

## 8.1 Checking and Adjusting Reel Height Sensor

The output voltage range of the auto reel height sensor can be checked from inside the combine or manually at the sensor..

For in-cab instructions, refer to the combine operator's manual

### DANGER

To avoid bodily injury or death from unexpected start-up or fall of a raised machine, always stop engine and remove key before leaving the operator's seat, and always engage safety props before going under the machine for any reason.

### WARNING

Check to be sure all bystanders have cleared the area.

#### IMPORTANT:

Ensure minimum reel height is properly set before adjusting reel height sensor. For instructions, refer to [6.13 Reel Clearance to Cutterbar, page 161](#).[6.13.1 Measuring Reel Clearance, page 161](#).

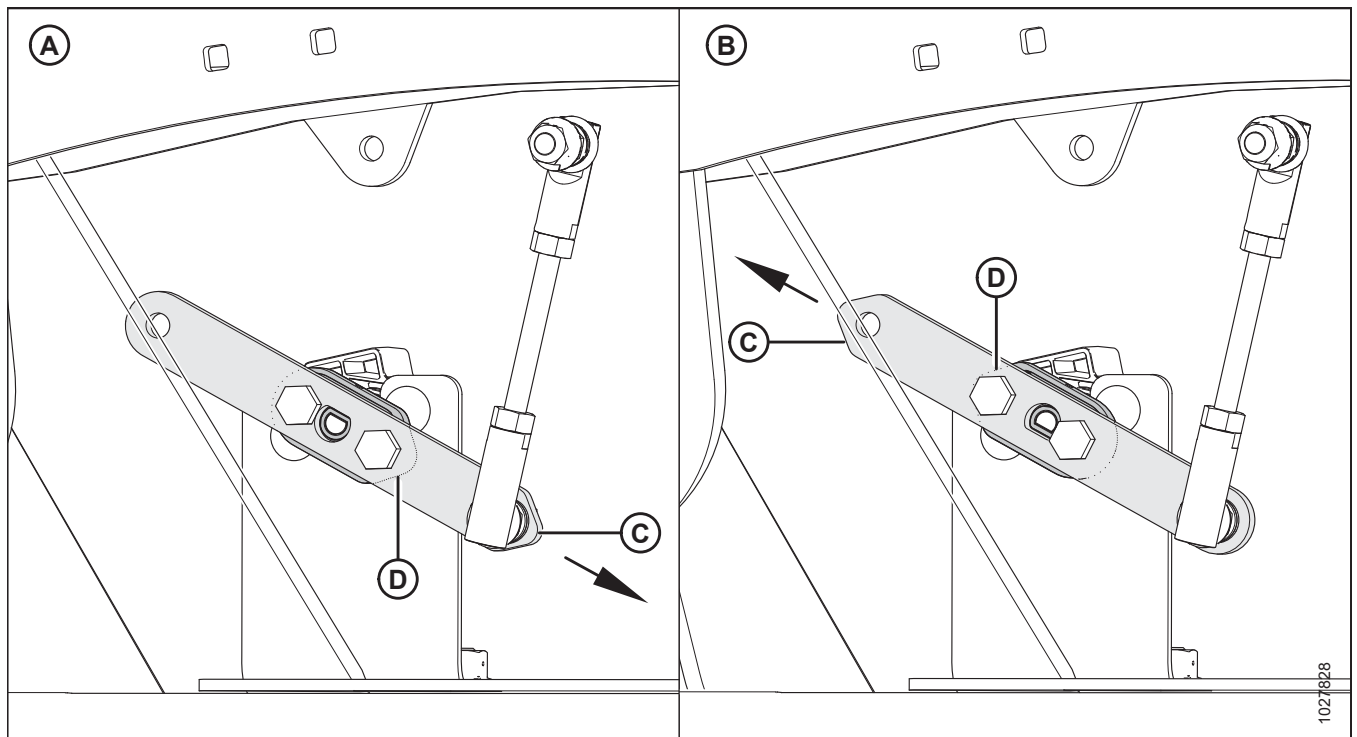

Figure 8.1: Sensor Arm/Pointer Configurations

A - Case/New Holland Configuration

B - John Deere/CLAAS/AGCO IDEAL™ Configuration

C - Sensor Arm (Shown Semitransparent)

D - Sensor Pointer (Shown Under Sensor Arm)

#### NOTE:

- For configuration (A), pointer (D) points to the **FRONT** of the header.
- For configuration (B), pointer (D) points to the **REAR** of the header.
- Sensor arm made semitransparent to show sensor pointer behind it.

## SETTING UP REEL HEIGHT SENSOR

1. Shut down the engine, and remove the key from the ignition.
2. Check that sensor arm (C) and pointer (D) are configured properly for your machine. Refer to Figure 8.1, page 365.

### IMPORTANT:

To measure the output voltage of the reel height sensor, the combine engine needs to be running and supplying power to the sensor. Always engage the combine parking brake and stay away from the reel.

**Table 8.1** Reel Height Sensor Voltage Limits

Combine Type	Voltage Range	
	X Voltage	Y Voltage
AGCO IDEAL™ Series	4.1–4.5 V	0.5–0.9 V
Case/New Holland	0.5–0.9 V	4.1–4.5 V
CLAAS	4.1–4.5 V	0.5–0.9 V
John Deere	4.1–4.5 V	0.5–0.9 V

### NOTE:

For CLAAS combines: To avoid a collision of the reel with the cab, the machine is equipped with an automatic reel height limitation. Some CLAAS combines have an automatic shutoff feature that engages when the automatic reel height limitation is reached. When raising the header by more than 80%, the reel is automatically lowered. The automatic lowering of the reel can be manually overridden, and a warning will appear on the CEBIS terminal.

### To check the voltage range manually, follow these steps:

1. Engage the combine parking brake.
2. Start the engine. For instructions, refer to the combine operator's manual.
3. Lower the reel fully.
4. Use the combine display or a voltmeter (if measuring the sensor manually) to measure voltage range Y. Refer to Table 8.1, page 366 for range requirements.
5. If using a voltmeter, measure the voltage between the ground wire (pin 2) and the signal wire (pin 3) at the reel height sensor (B).
6. Shut down the engine, and remove the key from the ignition.
7. Adjust length of threaded rod (A) to modify voltage range Y.

### NOTE:

Dimension (C) is factory set to 41.7 mm (1.6 in).

8. Repeat checking and adjusting until voltage range Y is within the range specified.
9. Start the engine.
10. Raise the reel fully.
11. Shut down the engine, and remove the key from the ignition.
12. Engage the reel safety props.
13. Start the engine.

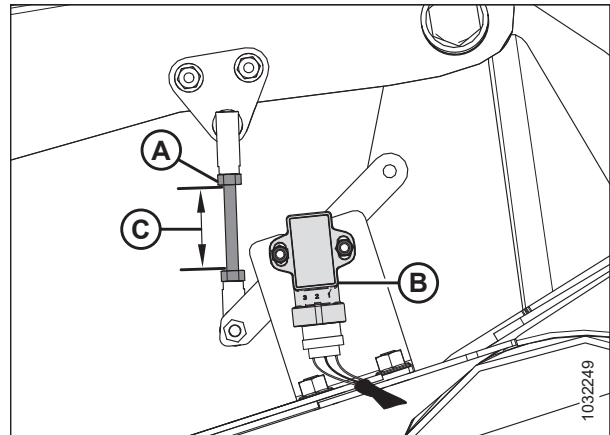

**Figure 8.2:** Reel Height Sensor – Right Reel Arm with Reel Down

## SETTING UP REEL HEIGHT SENSOR

14. Use the combine display or a voltmeter (if measuring the sensor manually) to measure voltage range **X**. Refer to Table 8.1, page 366 for range requirements.
15. If using a voltmeter, measure the voltage between the ground (Pin 2 wire) and the signal (Pin 3 wire) at the reel height sensor (A).
16. Shut down the engine, and remove the key from the ignition.
17. Loosen two M5 hex nuts (B) and rotate sensor (A) to achieve voltage range **X**.
18. Repeat checking and adjusting until voltage range **X** is within the range specified.
19. Disengage the reel safety props.
20. Start the engine.
21. Lower the reel fully.
22. Recheck voltage range **Y** and ensure it is still within the range specified. Adjust if required.

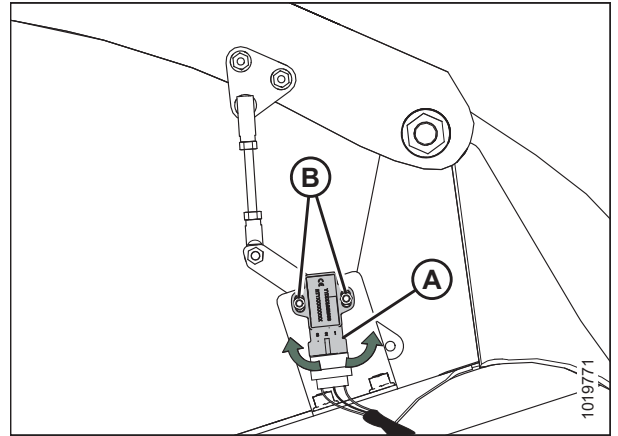

**Figure 8.3: Reel Height Sensor – Right Reel Arm with Reel Up**



## Chapter 9: Running up Header

To run up the header, follow these steps:

### DANGER

To avoid bodily injury or death from unexpected start-up or fall of a raised machine, always stop engine and remove key before leaving the operator's seat, and always engage safety props before going under the machine for any reason.

### WARNING

Never start or move the machine until you are sure all bystanders have cleared the area.

1. Start combine and raise header fully.
2. Engage the safety props. Refer to [10.1.1 Engaging Reel Safety Props, page 377](#).
3. Shut down the engine, and remove the key from the ignition.
4. Rotate latches (A) to unlock handles (B).
5. Hold pan (C) and rotate handles (B) to release pan. Lower pan to expose draper.

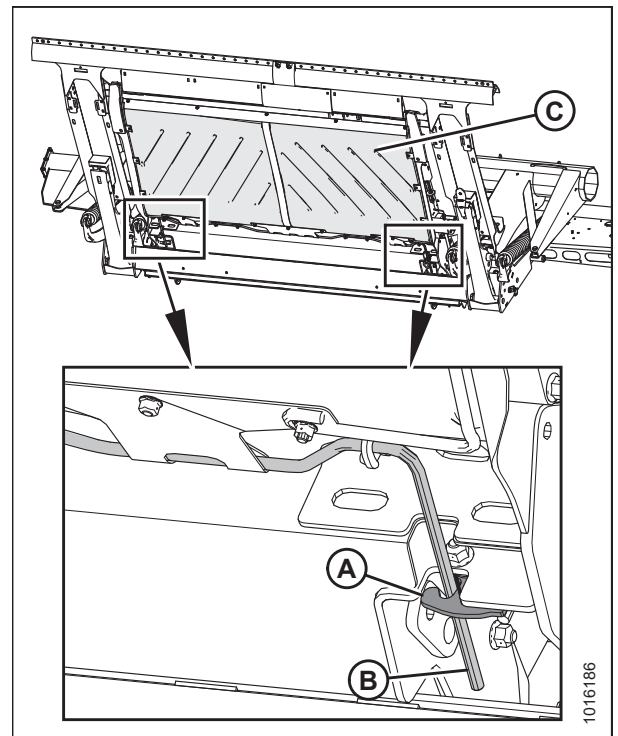

Figure 9.1: Float Module Plastic Pan

6. Check and remove debris from pan (A) and draper.

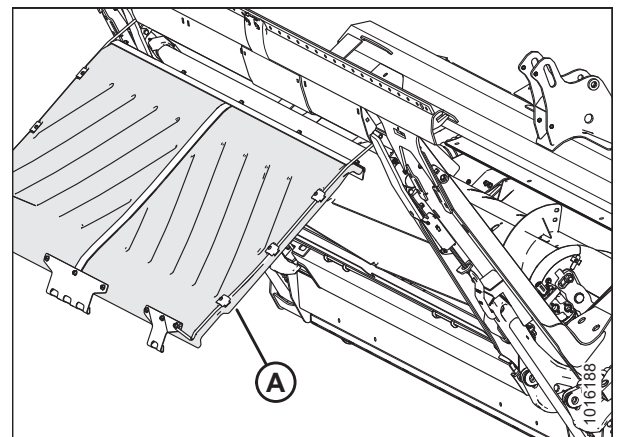

Figure 9.2: Float Module Plastic Pan

## RUNNING UP HEADER

7. Raise pan and rotate handle (A) so that rod engages clips (B) on pan.

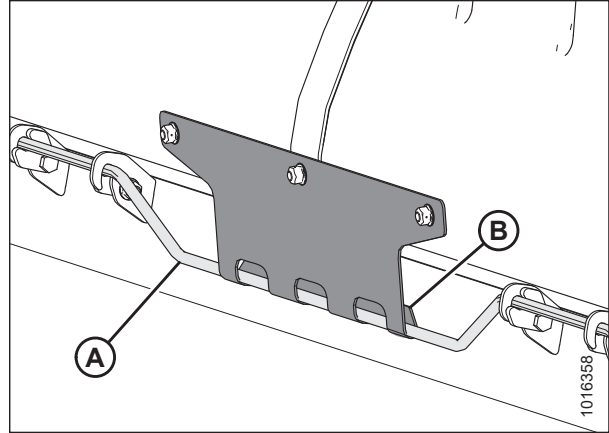

Figure 9.3: Clips Engaged

8. Push handle (A) into slot and secure it with latches (B).
9. Open left endshield.

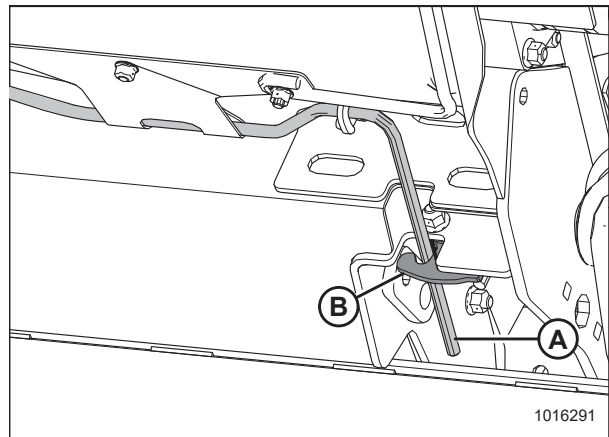

Figure 9.4: Latches Secured

## RUNNING UP HEADER

10. Ensure flow control (A) is set to position 6.
11. Ensure feeder house variable speed is set to MINIMUM.

### **WARNING**

**Never start or move the machine until you are sure all bystanders have cleared the area.**

12. Start combine and run the machine slowly for 5 minutes while watching and listening **FROM THE OPERATOR'S SEAT** for binding or interfering parts.

#### **NOTE:**

Reel and side drapers will not operate until oil flow fills the lines.

13. Run the machine at operating speed for 15 minutes. Listen for any unusual sounds or abnormal vibration.
14. Perform run-up check as listed on [Predelivery Checklist, page 393](#) (yellow sheet attached to this instruction) to ensure the machine is field-ready.

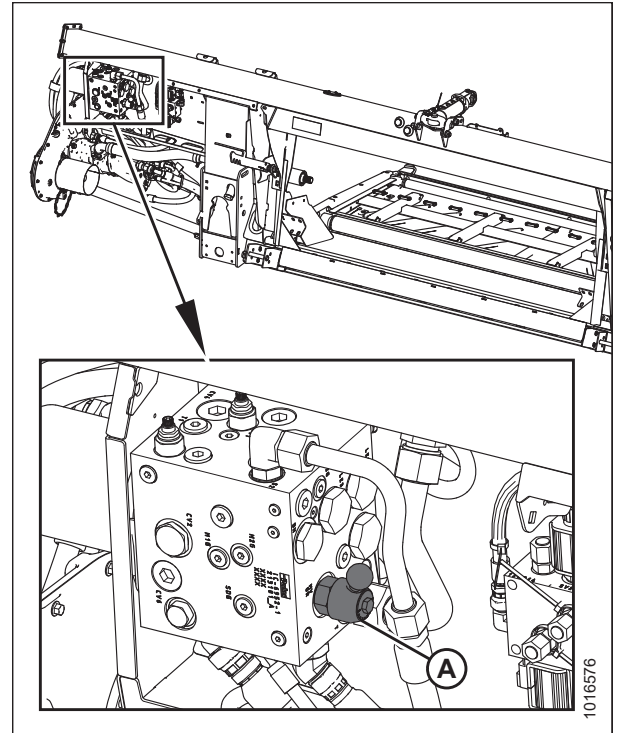

Figure 9.5: Flow Control

## 9.1 Adjusting Knife Speed

The header knife drive is driven by the hydraulic pump mounted on the float module. The following speeds are factory-set for the combine feeder house:

- AGCO: 625 rpm (includes Challenger, Gleaner, and Massey Ferguson)
- Case: 580 rpm
- John Deere: 490 rpm
- CLAAS: 750 rpm (420 on combine display)
- New Holland: 580 rpm

### **WARNING**

**To avoid bodily injury or death from unexpected startup of the machine, always stop the engine and remove the key from the ignition before leaving the operator's seat for any reason.**

#### **IMPORTANT:**

This is the **MINIMUM** speed setting for variable speed feeder houses. To avoid damage to the header, do **NOT** operate at speeds higher than the minimum speed settings.

## RUNNING UP HEADER

1. Stop combine engine and remove key.
2. Push release lever (A) located on the backside of the endshield to unlock the shield.
3. Pull endshield open using handle depression (B).

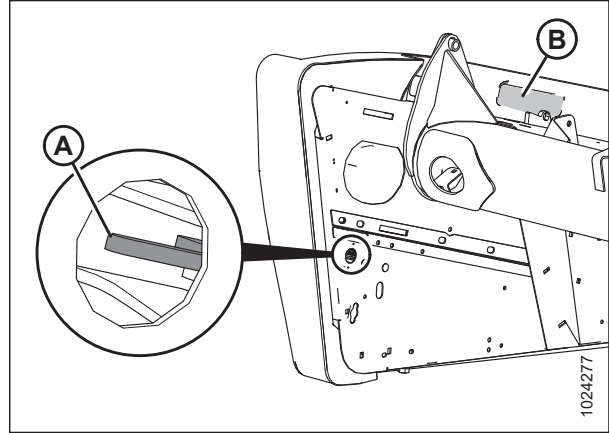

Figure 9.6: Endshield Latch Access

4. Pull endshield at handle depression (A). Endshield is retained by a hinge tab (B) and will open in direction (C).

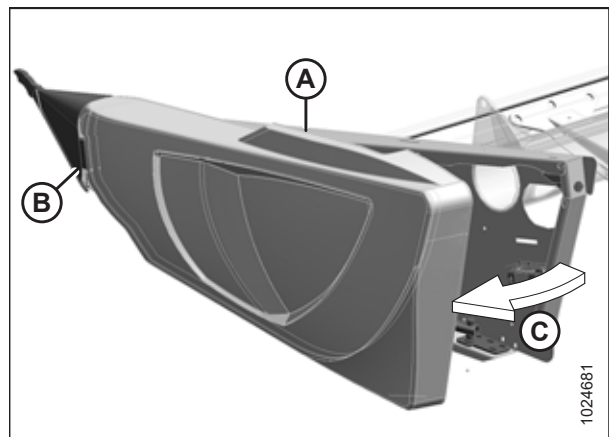

Figure 9.7: Left Endshield

5. If additional clearance is required, pull the endshield free of hinge tab (A) and swing shield towards the rear of the header.
6. Engage safety catch (B) on hinge arm to secure the shield in fully-open position.

### **WARNING**

Clear the area of other persons, pets etc. Keep children away from machinery. Walk around the machine to be sure no one is under, on, or close to it.

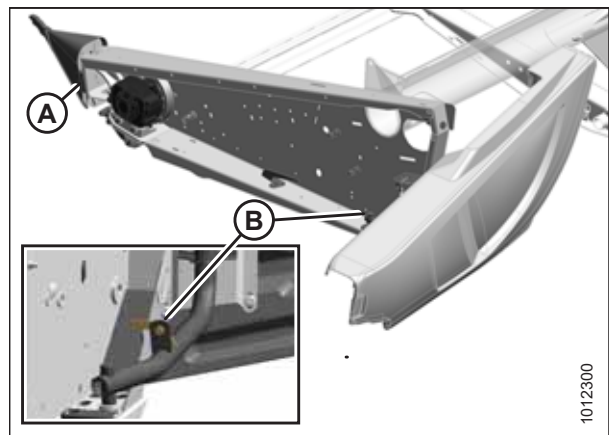

Figure 9.8: Left Endshield



## RUNNING UP HEADER

7. Start engine, engage header drive, and run combine at operating rpm.
8. Check the rpm of knife drive box pulley (A) using a handheld tachometer.
9. Stop engine, remove key, and close endshield.



Figure 9.9: Knife Drive Box

10. Compare actual pulley rpm with values in the following chart:

**Table 9.1 Recommended Knife Drive Speed (rpm)**

Header Size	Recommended Knife Drive Speed Range (rpm)	
	Single Knife	Double Knife
FD125	600–725	—
FD130	600–700	—
FD135	550–600	—
FD140	525–600	550–700
FD145	—	550–700

11. If adjustment to knife drive box pulley rpm is necessary, refer to the header technical manual.

## 9.2 Performing Post Run-Up Adjustments

Stop engine and perform post run-up check as listed on the Predelivery Checklist (yellow sheet attached to this instruction *Predelivery Checklist, page 393*) to ensure machine is field-ready.

### **WARNING**

**To avoid bodily injury or death from unexpected startup of machine, always stop engine and remove key before adjusting machine.**

Some adjustments may be necessary after the run-up. Refer to the following:

- *9.2.1 Adjusting Knife, page 375*
- *9.2.2 Checking and Adjusting Feed Draper Tension, page 376*

### 9.2.1 Adjusting Knife

#### WARNING

To avoid bodily injury or death from unexpected startup of machine, always stop engine and remove key before adjusting machine.

1. Stop engine and remove the key.
2. Check guards for signs of heating during run-up due to insufficient clearance between guard and knife.
3. If heating is evident, check gap between knifehead (A) and pitman arm (B). A business card should slide easily through the gap. If not, adjust gap by loosening bolt and tapping knifehead (A) with a hammer. Retighten bolt.

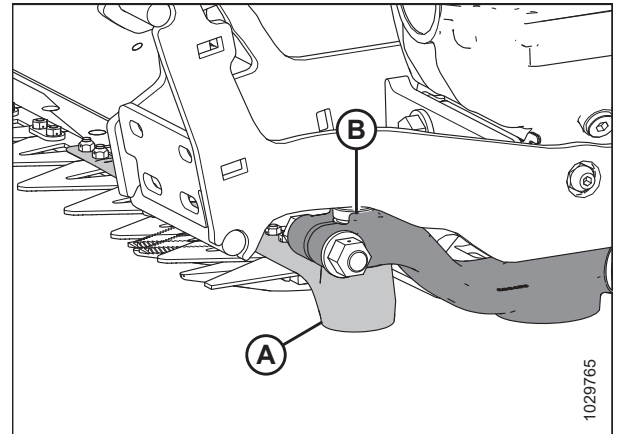

Figure 9.10: Knifehead and Pitman Arm

4. Adjust guard alignment as necessary using guard straightening tool (MD #140135). Adjust guard tips upwards by positioning tool as shown, and pulling up.



Figure 9.11: Straightening Tool – Upward Adjustment

5. Adjust guard tips downward by positioning tool as shown, and pushing down.

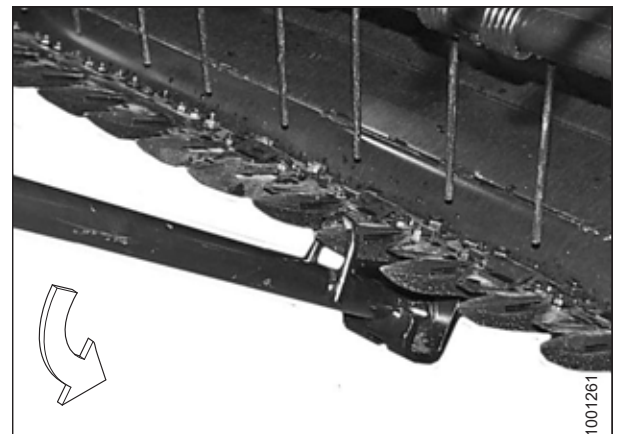

Figure 9.12: Straightening Tool – Downward Adjustment

## 9.2.2 Checking and Adjusting Feed Draper Tension

### DANGER

To avoid bodily injury or death from unexpected start-up or fall of a raised machine, always stop engine and remove key before leaving the operator's seat, and always engage safety props before going under the machine for any reason.

1. Raise the header fully.
2. Shut down the engine, and remove the key from the ignition.
3. Engage the header safety props.

#### **Checking draper tension:**

4. Ensure the draper guide (the rubber track on the underside of the draper) is properly engaged in the groove on the drive roller, and the idler roller is between the guides.

#### **NOTE:**

Illustrations show the left side of the float module. The right side is opposite.

#### **NOTE:**

The default position of spring retainer (A) (white indicator) is centered (B) in the spring box window; however, the position of the spring retainer varies with draper tracking adjustment at the factory.

5. Check the position of white indicator (A). If the feed draper tracks properly and the spring retainers on both sides of the draper are correctly positioned, then no adjustment is necessary.
6. If adjustment is necessary, proceed to Step 7, page 376.

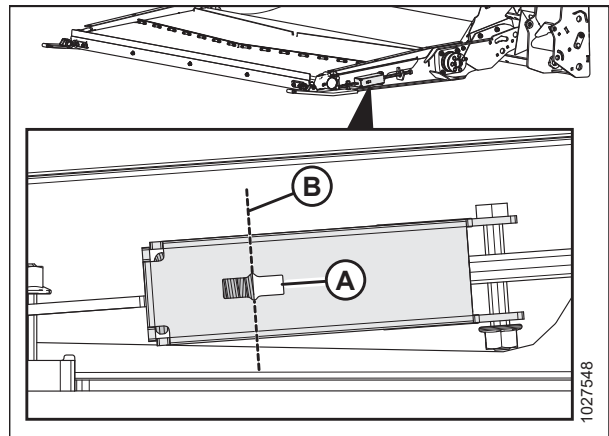

Figure 9.13: Feed Draper Tensioner

#### **Adjusting draper tension:**

7. Adjust the draper tension by loosening jam nut (A) and turning bolt (B) clockwise to increase draper tension or turning bolt (B) counterclockwise to decrease draper tension. Draper tension can be adjusted as follows:

- Loosened to 3 mm (1/8 in.) (D) (aft of center in indicator window [E])
- Tightened to 6 mm (1/4 in.) (C) (forward of center in indicator window [E])

#### **NOTE:**

For small tension adjustments, you may need to only adjust one side of the draper. For larger tension adjustments and to avoid uneven draper tracking, you may need to adjust both sides of the draper an equal amount.

8. Tighten jam nut (A).

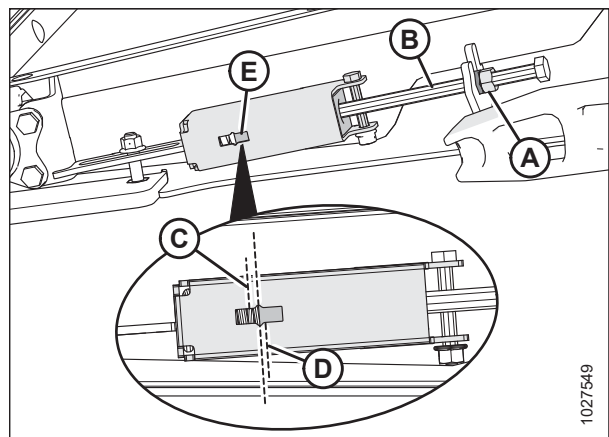

Figure 9.14: Feed Draper Tensioner

## Chapter 10: Reference

### 10.1 Reel Safety Props

The reel safety props are located on the reel support arms and prevent the reel from unexpectedly lowering.

#### DANGER

To avoid bodily injury or death from unexpected start-up or fall of a raised machine, always stop engine and remove key before leaving the operator's seat, and always engage safety props before going under the machine for any reason.

#### IMPORTANT:

To prevent damage to the reel support arms, do **NOT** transport the header with the reel safety props engaged.

#### 10.1.1 Engaging Reel Safety Props

1. Raise reel to maximum height.
2. Move reel safety props (A) to engaged position.

##### NOTE:

Keep pivot bolt (B) sufficiently tight so prop remains in stored position when not in use, but can be engaged using hand force.

##### NOTE:

The left safety prop is shown in the illustration at right. Right safety prop is opposite.

3. Repeat on right reel arm.

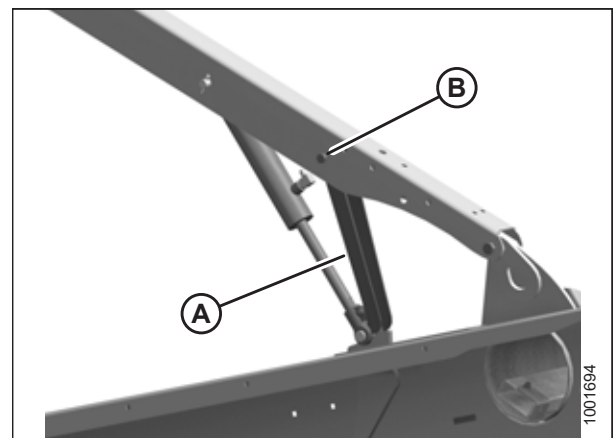

Figure 10.1: Engaged Reel Safety Prop

## REFERENCE

4. Use handle (A) to move lock rod to inboard position (B), which engages pin (C) under prop.
5. Lower reel until safety props contact the outer arm cylinder mounts and the center arm pins.

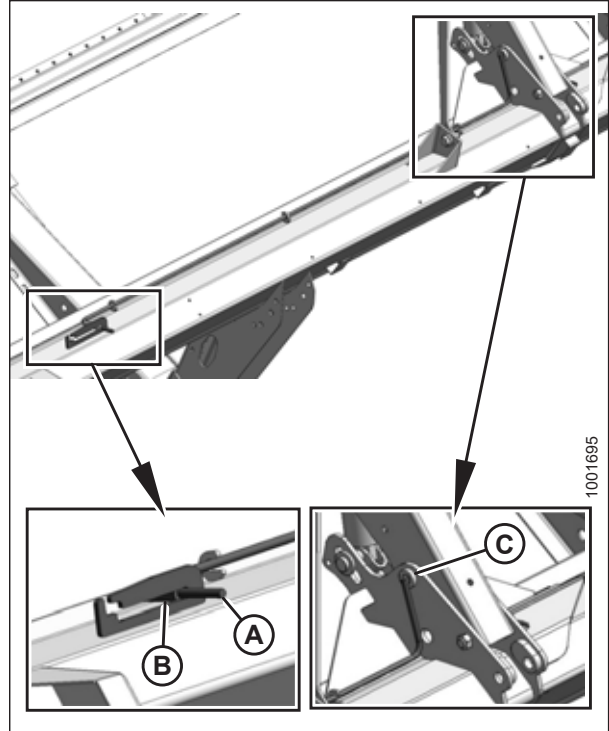

Figure 10.2: Reel Safety Prop – Center Arm

### 10.1.2 Disengaging Reel Safety Props

1. Raise the reel to its maximum height.
2. Move reel safety props (A) back inside the reel arms. Repeat at the opposite end of the reel.

**NOTE:**

The left safety prop is shown in the illustration at right. Right safety prop is opposite.

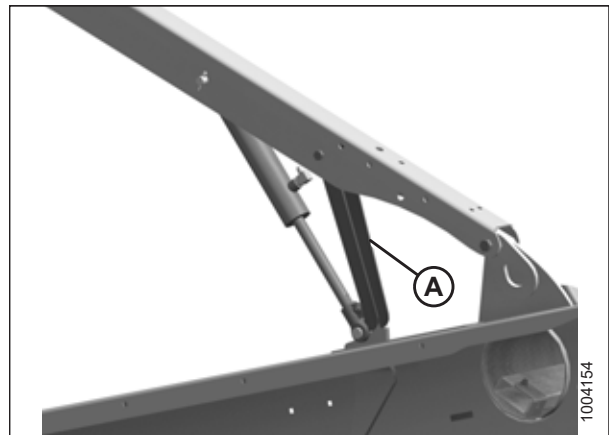

Figure 10.3: Reel Safety Prop

## REFERENCE

3. Use handle (B) to move lock rod (A) to the outboard position.

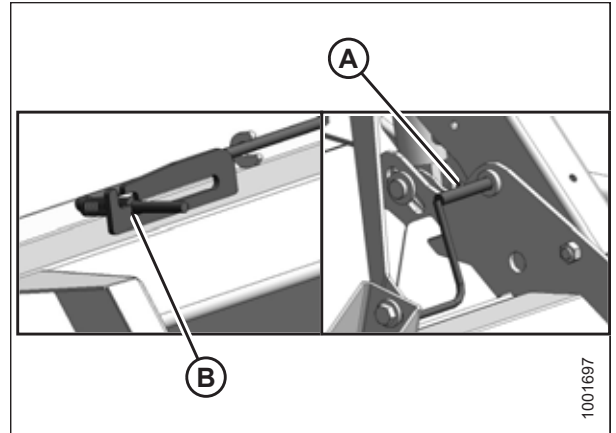

Figure 10.4: Reel Safety Prop – Center Arm

## 10.2 Torque Specifications

The following tables provide correct torque values for various bolts, cap screws, and hydraulic fittings.

- Tighten all bolts to torque values specified in charts (unless otherwise noted throughout this manual).
- Replace hardware with same strength and grade of bolt.
- Use torque value tables as a guide and periodically check tightness of bolts.
- Understand torque categories for bolts and cap screws by using their identifying head markings.

### Jam nuts

When applying torque to finished jam nuts, multiply the torque applied to regular nuts by  $f=0.65$ .

### Self-tapping screws

Standard torque is to be used (**NOT** to be used on critical or structurally important joints).

### 10.2.1 Metric Bolt Specifications

Table 10.1 Metric Class 8.8 Bolts and Class 9 Free Spinning Nut

Nominal Size (A)	Torque (Nm)		Torque (lbf-ft) (*lbf-in)	
	Min.	Max.	Min.	Max.
3-0.5	1.4	1.6	*13	*14
3.5-0.6	2.2	2.5	*20	*22
4-0.7	3.3	3.7	*29	*32
5-0.8	6.7	7.4	*59	*66
6-1.0	11.4	12.6	*101	*112
8-1.25	28	30	20	23
10-1.5	55	60	40	45
12-1.75	95	105	70	78
14-2.0	152	168	113	124
16-2.0	236	261	175	193
20-2.5	460	509	341	377
24-3.0	796	879	589	651

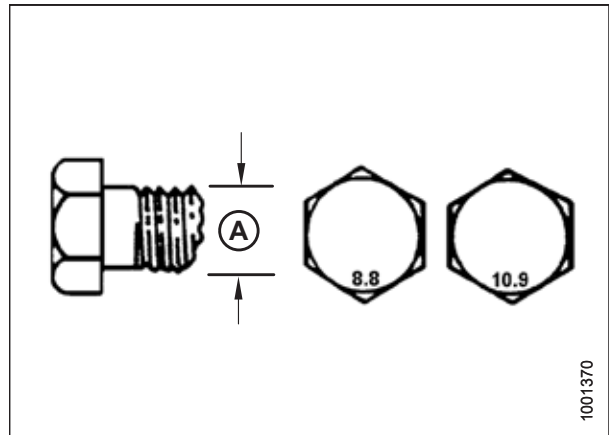

Figure 10.5: Bolt Grades

Table 10.2 Metric Class 8.8 Bolts and Class 9 Distorted Thread Nut

Nominal Size (A)	Torque (Nm)		Torque (lbf-ft) (*lbf-in)	
	Min.	Max.	Min.	Max.
3-0.5	1	1.1	*9	*10
3.5-0.6	1.5	1.7	*14	*15
4-0.7	2.3	2.5	*20	*22
5-0.8	4.5	5	*40	*45
6-1.0	7.7	8.6	*69	*76
8-1.25	18.8	20.8	*167	*185
10-1.5	37	41	28	30
12-1.75	65	72	48	53

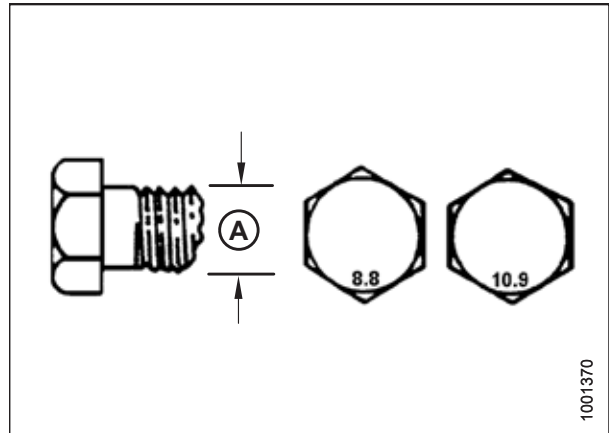

Figure 10.6: Bolt Grades



REFERENCE

**Table 10.2 Metric Class 8.8 Bolts and Class 9 Distorted Thread Nut (continued)**

Nominal Size (A)	Torque (Nm)		Torque (lbf-ft) (*lbf-in)	
	Min.	Max.	Min.	Max.
14-2.0	104	115	77	85
16-2.0	161	178	119	132
20-2.5	314	347	233	257
24-3.0	543	600	402	444

**Table 10.3 Metric Class 10.9 Bolts and Class 10 Free Spinning Nut**

Nominal Size (A)	Torque (Nm)		Torque (lbf-ft) (*lbf-in)	
	Min.	Max.	Min.	Max.
3-0.5	1.8	2	*18	*19
3.5-0.6	2.8	3.1	*27	*30
4-0.7	4.2	4.6	*41	*45
5-0.8	8.4	9.3	*82	*91
6-1.0	14.3	15.8	*140	*154
8-1.25	38	42	28	31
10-1.5	75	83	56	62
12-1.75	132	145	97	108
14-2.0	210	232	156	172
16-2.0	326	360	242	267
20-2.5	637	704	472	521
24-3.0	1101	1217	815	901

**Table 10.4 Metric Class 10.9 Bolts and Class 10 Distorted Thread Nut**

Nominal Size (A)	Torque (Nm)		Torque (lbf-ft) (*lbf-in)	
	Min.	Max.	Min.	Max.
3-0.5	1.3	1.5	*12	*13
3.5-0.6	2.1	2.3	*19	*21
4-0.7	3.1	3.4	*28	*31
5-0.8	6.3	7	*56	*62
6-1.0	10.7	11.8	*95	*105
8-1.25	26	29	19	21
10-1.5	51	57	38	42
12-1.75	90	99	66	73
14-2.0	143	158	106	117
16-2.0	222	246	165	182
20-2.5	434	480	322	356
24-3.0	750	829	556	614

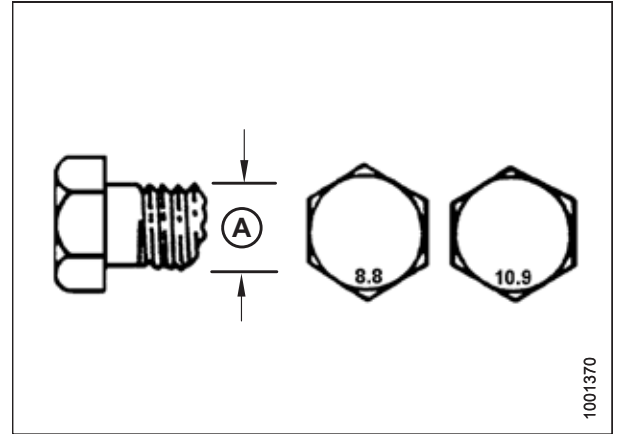

Figure 10.7: Bolt Grades

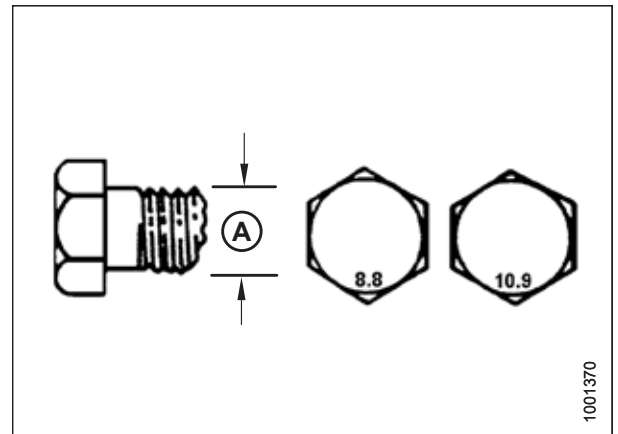

Figure 10.8: Bolt Grades

### 10.2.2 Metric Bolt Specifications Bolting into Cast Aluminum

Table 10.5 Metric Bolt Bolting into Cast Aluminum

Nominal Size (A)	Bolt Torque			
	8.8 (Cast Aluminum)		10.9 (Cast Aluminum)	
	Nm	lbf-ft	Nm	lbf-ft
M3	–	–	–	1
M4	–	–	4	2.6
M5	–	–	8	5.5
M6	9	6	12	9
M8	20	14	28	20
M10	40	28	55	40
M12	70	52	100	73
M14	–	–	–	–
M16	–	–	–	–

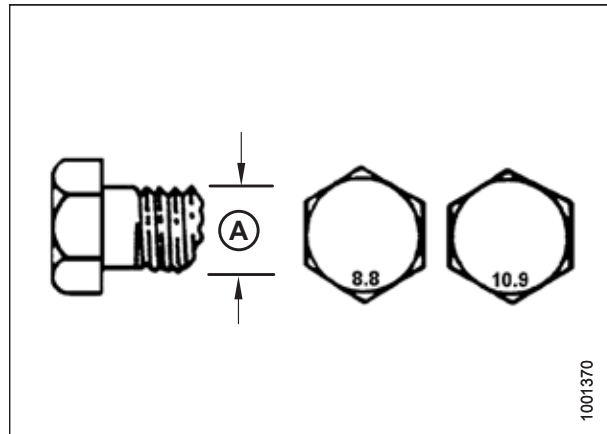

Figure 10.9: Bolt Grades

### 10.2.3 Flare-Type Hydraulic Fittings

1. Check flare (A) and flare seat (B) for defects that might cause leakage.
2. Align tube (C) with fitting (D) and thread nut (E) onto fitting without lubrication until contact has been made between flared surfaces.
3. Torque fitting nut (E) to specified number of flats from finger tight (FFFT) or to a given torque value in Table 10.6, page 382.
4. Use two wrenches to prevent fitting (D) from rotating. Place one wrench on fitting body (D), and tighten nut (E) with other wrench to torque shown.
5. Assess final condition of connection.

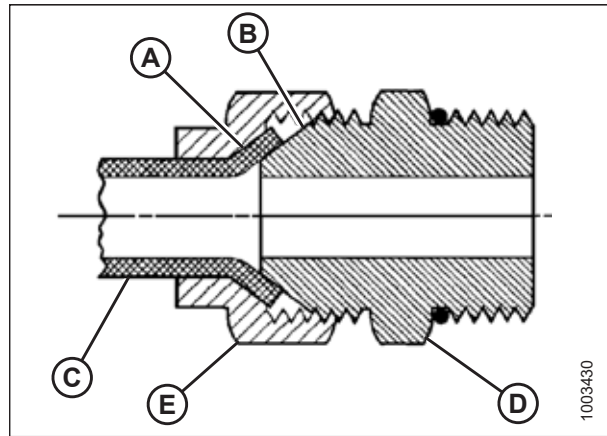

Figure 10.10: Hydraulic Fitting

Table 10.6 Flare-Type Hydraulic Tube Fittings

SAE Dash Size	Thread Size (in.)	Torque Value <sup>4</sup>		Flats from Finger Tight (FFFT)	
		Nm	lbf-ft	Tube	Swivel Nut or Hose
-2	5/16–24	4–5	3–4	–	–
-3	3/8–24	7–8	5–6	–	–
-4	7/16–20	18–19	13–14	2 1/2	2
-5	1/2–20	19–21	14–15	2	2
-6	9/16–18	30–33	22–24	2	1 1/2

4. Torque values shown are based on lubricated connections as in reassembly.

REFERENCE

Table 10.6 Flare-Type Hydraulic Tube Fittings (continued)

SAE Dash Size	Thread Size (in.)	Torque Value <sup>5</sup>		Flats from Finger Tight (FFFT)	
		Nm	lbf·ft	Tube	Swivel Nut or Hose
-8	3/4-16	57-63	42-46	2	1 1/2
-10	7/8-14	81-89	60-66	1 1/2	1 1/2
-12	1 1/16-12	113-124	83-91	1 1/2	1 1/4
-14	1 3/16-12	136-149	100-110	1 1/2	1 1/4
-16	1 5/16-12	160-176	118-130	1 1/2	1
-20	1 5/8-12	228-250	168-184	1	1
-24	1 7/8-12	264-291	195-215	1	1
-32	2 1/2-12	359-395	265-291	1	1
-40	3-12	—	—	1	1

### 10.2.4 O-Ring Boss Hydraulic Fittings – Adjustable

1. Inspect O-ring (A) and seat (B) for dirt or obvious defects.
2. Back off lock nut (C) as far as possible. Ensure that washer (D) is loose and is pushed toward lock nut (C) as far as possible.
3. Check that O-ring (A) is **NOT** on threads and adjust if necessary.
4. Apply hydraulic system oil to O-ring (A).

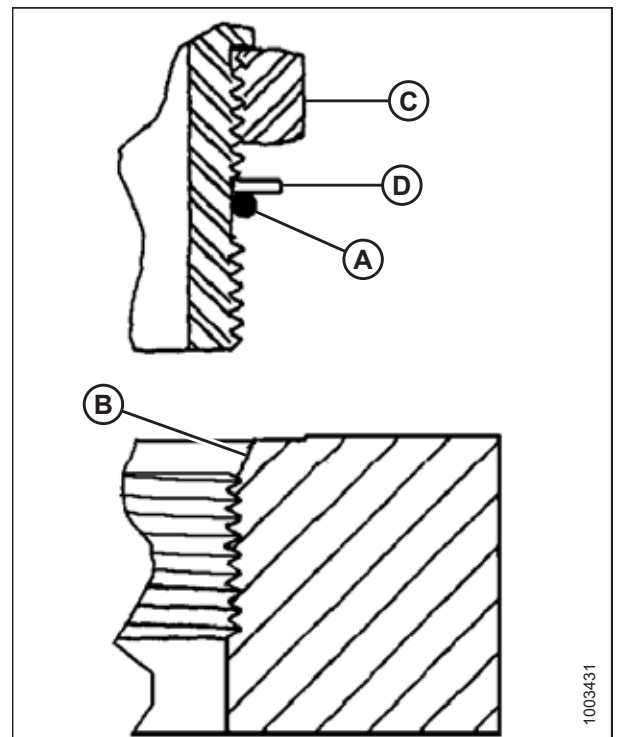

Figure 10.11: Hydraulic Fitting

5. Torque values shown are based on lubricated connections as in reassembly.

REFERENCE

5. Install fitting (B) into port until backup washer (D) and O-ring (A) contact part face (E).
6. Position angle fittings by unscrewing no more than one turn.
7. Turn lock nut (C) down to washer (D) and tighten to torque shown. Use two wrenches, one on fitting (B) and other on lock nut (C).
8. Check final condition of fitting.

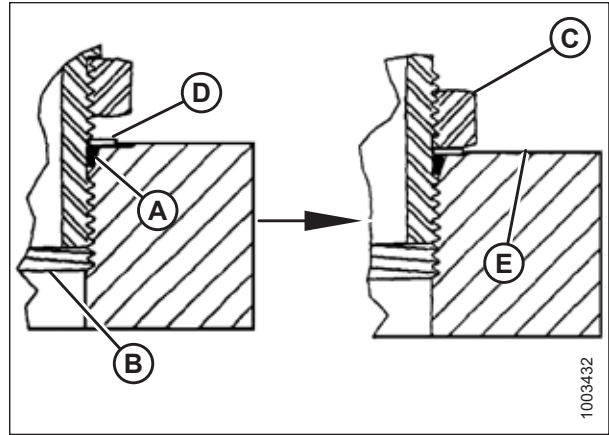

Figure 10.12: Hydraulic Fitting

Table 10.7 O-Ring Boss (ORB) Hydraulic Fittings – Adjustable

SAE Dash Size	Thread Size (in.)	Torque Value <sup>6</sup>	
		Nm	lbf·ft (*lbf·in)
-2	5/16-24	6-7	*53-62
-3	3/8-24	12-13	*106-115
-4	7/16-20	19-21	14-15
-5	1/2-20	21-33	15-24
-6	9/16-18	26-29	19-21
-8	3/4-16	46-50	34-37
-10	7/8-14	75-82	55-60
-12	1 1/16-12	120-132	88-97
-14	1 3/8-12	153-168	113-124
-16	1 5/16-12	176-193	130-142
-20	1 5/8-12	221-243	163-179
-24	1 7/8-12	270-298	199-220
-32	2 1/2-12	332-365	245-269

6. Torque values shown are based on lubricated connections as in reassembly.

REFERENCE

### 10.2.5 O-Ring Boss Hydraulic Fittings – Non-Adjustable

1. Inspect O-ring (A) and seat (B) for dirt or obvious defects.
2. Check that O-ring (A) is **NOT** on threads and adjust if necessary.
3. Apply hydraulic system oil to O-ring.
4. Install fitting (C) into port until fitting is hand-tight.
5. Torque fitting (C) according to values in Table 10.8, page 385.
6. Check final condition of fitting.

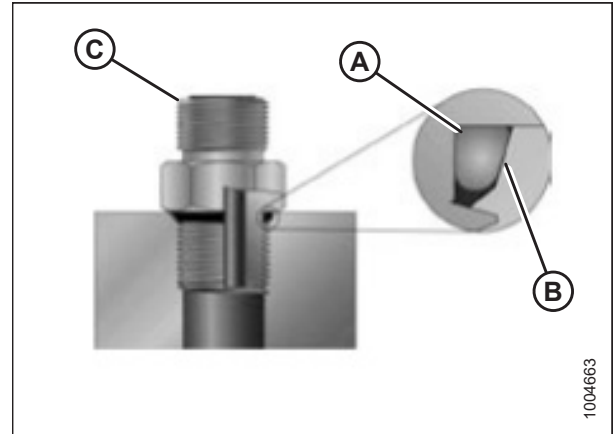

Figure 10.13: Hydraulic Fitting

Table 10.8 O-Ring Boss (ORB) Hydraulic Fittings – Non-Adjustable

SAE Dash Size	Thread Size (in.)	Torque Value <sup>7</sup>	
		Nm	lbf·ft (*lbf·in)
-2	5/16-24	6-7	*53-62
-3	3/8-24	12-13	*106-115
-4	7/16-20	19-21	14-15
-5	1/2-20	21-33	15-24
-6	9/16-18	26-29	19-21
-8	3/4-16	46-50	34-37
-10	7/8-14	75-82	55-60
-12	1 1/16-12	120-132	88-97
-14	1 3/8-12	153-168	113-124
-16	1 5/16-12	176-193	130-142
-20	1 5/8-12	221-243	163-179
-24	1 7/8-12	270-298	199-220
-32	2 1/2-12	332-365	245-269

7. Torque values shown are based on lubricated connections as in reassembly.

### 10.2.6 O-Ring Face Seal Hydraulic Fittings

1. Check components to ensure that sealing surfaces and fitting threads are free of burrs, nicks, scratches, or any foreign material.



Figure 10.14: Hydraulic Fitting

2. Apply hydraulic system oil to O-ring (B).
3. Align tube or hose assembly so that flat face of sleeve (A) or (C) comes in full contact with O-ring (B).
4. Thread tube or hose nut (D) until hand-tight. The nut should turn freely until it is bottomed out.
5. Torque fittings according to values in Table 10.9, page 386.

**NOTE:**

If applicable, hold hex on fitting body (E) to prevent rotation of fitting body and hose when tightening fitting nut (D).

6. Use three wrenches when assembling unions or joining two hoses together.
7. Check final condition of fitting.

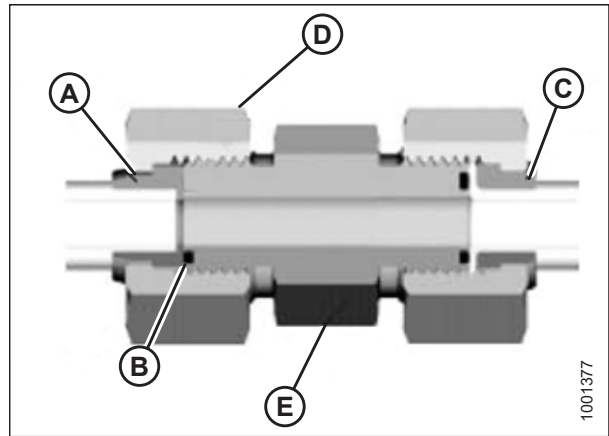

Figure 10.15: Hydraulic Fitting

**Table 10.9 O-Ring Face Seal (ORFS) Hydraulic Fittings**

SAE Dash Size	Thread Size (in.)	Tube O.D. (in.)	Torque Value <sup>8</sup>	
			Nm	lbf-ft
-3	Note <sup>9</sup>	3/16	-	-
-4	9/16	1/4	25-28	18-21
-5	Note <sup>9</sup>	5/16	-	-
-6	11/16	3/8	40-44	29-32
-8	13/16	1/2	55-61	41-45
-10	1	5/8	80-88	59-65
-12	1 3/16	3/4	115-127	85-94
-14	Note <sup>9</sup>	7/8	-	-

8. Torque values and angles shown are based on lubricated connection as in reassembly.

9. O-ring face seal type end not defined for this tube size.

## REFERENCE

**Table 10.9 O-Ring Face Seal (ORFS) Hydraulic Fittings (continued)**

SAE Dash Size	Thread Size (in.)	Tube O.D. (in.)	Torque Value <sup>10</sup>	
			Nm	lbf-ft
-16	1 7/16	1	150–165	111–122
-20	1 11/16	1 1/4	205–226	151–167
-24	1–2	1 1/2	315–347	232–256
-32	2 1/2	2	510–561	376–414

### 10.2.7 Tapered Pipe Thread Fittings

Assemble pipe fittings as follows:

1. Check components to ensure that fitting and port threads are free of burrs, nicks, scratches, or any form of contamination.
2. Apply pipe thread sealant (paste type) to external pipe threads.
3. Thread fitting into port until hand-tight.
4. Torque connector to appropriate torque angle. The turns from finger tight (TFFT) and flats from finger tight (FFFT) values are shown in Table 10.10, page 387. Make sure that tube end of a shaped connector (typically 45° or 90°) is aligned to receive incoming tube or hose assembly. Always finish alignment of fitting in tightening direction. Never back off (loosen) pipe threaded connectors to achieve alignment.
5. Clean all residue and any excess thread conditioner with appropriate cleaner.
6. Assess final condition of fitting. Pay special attention to possibility of cracks to port opening.
7. Mark final position of fitting. If a fitting leaks, disassemble fitting and check for damage.

**NOTE:**

Overtorque failure of fittings may not be evident until fittings are disassembled.

**Table 10.10 Hydraulic Fitting Pipe Thread**

Tapered Pipe Thread Size	Recommended TFFT	Recommended FFFT
1/8–27	2–3	12–18
1/4–18	2–3	12–18
3/8–18	2–3	12–18
1/2–14	2–3	12–18
3/4–14	1.5–2.5	12–18
1–11 1/2	1.5–2.5	9–15
1 1/4–11 1/2	1.5–2.5	9–15
1 1/2–11 1/2	1.5–2.5	9–15
2–11 1/2	1.5–2.5	9–15

10. Torque values and angles shown are based on lubricated connection as in reassembly.

### 10.3 Lifting Equipment Requirements

The following topic describes the minimum equipment requirements for lifting headers.

**⚠ WARNING**

To avoid injury to bystanders from being struck by machinery, do NOT allow people to stand in unloading area.

**⚠ WARNING**

Equipment used for loading and unloading must meet or exceed the minimum specified requirements. Using inadequate equipment may result in vehicle tipping, machine damage, or chain breakage.

**NOTE:**

When a header and float module are ordered together, they are shipped with the float module already installed in the header.

**IMPORTANT:**

Forklifts are normally rated for a load center 610 mm (24 in.) ahead of back end of the forks. To obtain the forklift capacity for a load center (A) at 1220 mm (48 in.) (B), check with your forklift distributor. The minimum fork length (C) is 1981 mm (78 in.).

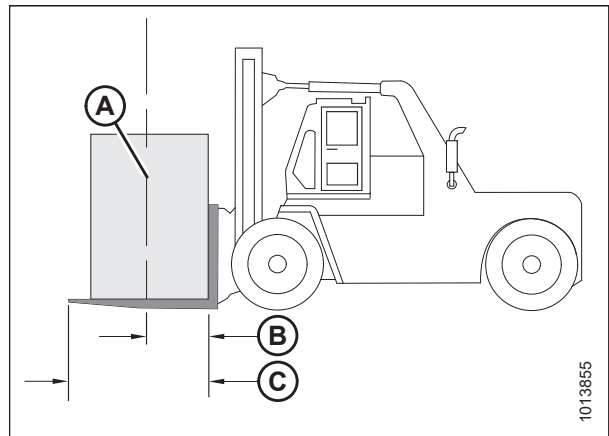

**Figure 10.16: Minimum Lifting Capacity**

- A - Load Center of Gravity
- B - Load Center 1220 mm (48 in.) from Back of Forks
- C - Minimum Fork Length 1981 mm (78 in.)

**Table 10.11 Lifting Chain Requirements**

Type	Overhead lifting quality (1/2 in.)
Minimum Load	2270 kg (5000 lb.)



## 10.4 Conversion Chart

Table 10.12 Conversion Chart

Quantity	SI Units (Metric)		Factor	US Customary Units (Standard)	
	Unit Name	Abbreviation		Unit Name	Abbreviation
Area	hectare	ha	$\times 2.4710 =$	acre	acres
Flow	liters per minute	L/min	$\times 0.2642 =$	US gallons per minute	gpm
Force	Newton	N	$\times 0.2248 =$	pound force	lbf
Length	millimeter	mm	$\times 0.0394 =$	inch	in.
Length	meter	m	$\times 3.2808 =$	foot	ft.
Power	kilowatt	kW	$\times 1.341 =$	horsepower	hp
Pressure	kilopascal	kPa	$\times 0.145 =$	pounds per square inch	psi
Pressure	megapascal	MPa	$\times 145.038 =$	pounds per square inch	psi
Pressure	bar (Non-SI)	bar	$\times 14.5038 =$	pounds per square inch	psi
Torque	Newton meter	Nm	$\times 0.7376 =$	pound feet or foot pounds	lbf-ft
Torque	Newton meter	Nm	$\times 8.8507 =$	pound inches or inch pounds	lbf-in
Temperature	degrees Celsius	°C	$(^{\circ}\text{C} \times 1.8) + 32 =$	degrees Fahrenheit	°F
Velocity	meters per minute	m/min	$\times 3.2808 =$	feet per minute	ft/min
Velocity	meters per second	m/s	$\times 3.2808 =$	feet per second	ft/s
Velocity	kilometers per hour	km/h	$\times 0.6214 =$	miles per hour	mph
Volume	liter	L	$\times 0.2642 =$	US gallon	US gal
Volume	milliliter	mL	$\times 0.0338 =$	ounce	oz.
Volume	cubic centimeter	cm <sup>3</sup> or cc	$\times 0.061 =$	cubic inch	in. <sup>3</sup>
Weight	kilogram	kg	$\times 2.2046 =$	pound	lb.

**REFERENCE**

## 10.5 Definitions

The following terms and acronyms may be used in this instruction:

<b>Term</b>	<b>Definition</b>
AHHC	Automatic Header Height Control
API	American Petroleum Institute
ASTM	American Society of Testing and Materials
Bolt	A headed and externally threaded fastener that is designed to be paired with a nut
Center-link	A hydraulic cylinder link between the header and machine used to change header angle
CGVW	Combined gross vehicle weight
D1 Series Header	MacDon D120, D125, D130, D135, D140, and D145 combine draper header
DDD	Double-draper drive
DK	Double knife
DKD	Double-knife drive
DR	Double reel
Export header	Header configuration typical outside North America
FD1 Series header	MacDon FD125, FD130, FD135, FD140, or FD145 combine FlexDraper® header
FFFT	Flats from finger tight
Finger tight	Finger tight is a reference position where sealing surfaces or components are making contact with each other, and fitting has been tightened to a point where fitting is no longer loose
FM100	Float module used with a D1 or FD1 Series header for combining
GVW	Gross vehicle weight
Hard joint	A joint made with use of a fastener where joining materials are highly incompressible
Header	A machine that cuts crop and feeds it into an attached combine
Hex key	A tool of hexagonal cross-section used to drive bolts and screws that have a hexagonal socket in head (internal-wrenching hexagon drive); also known as an Allen key and various other synonyms
HDS	Hydraulic deck shift
hp	Horsepower
JIC	Joint Industrial Council: A standards body that developed standard sizing and shape for original 37° flared fitting
Knife	A cutting device which uses a reciprocating cutter (also called a sickle)
MDS	Mechanical deck shift
n/a	Not applicable
North American header	Header configuration typical in North America
NPT	National Pipe Thread: A style of fitting used for low-pressure port openings. Threads on NPT fittings are uniquely tapered for an interference fit
Nut	An internally threaded fastener that is designed to be paired with a bolt

## REFERENCE

Term	Definition
ORB	O-ring boss: A style of fitting commonly used in port openings on manifolds, pumps, and motors
ORFS	O-ring face seal: A style of fitting commonly used for connecting hoses and tubes. This style of fitting is also commonly called ORS, which stands for O-ring seal
RoHS (Reduction of Hazardous Substances)	A directive by the European Union to restrict use of certain hazardous substances (such as hexavalent chromium used in some yellow zinc platings)
rpm	Revolutions per minute
SAE	Society of Automotive Engineers
Screw	A headed and externally threaded fastener that threads into preformed threads or forms its own thread into a mating part
SDD	Single-drapers drive
Soft joint	A joint made with use of a fastener where joining materials are compressible or experience relaxation over a period of time
spm	Strokes per minute
Tension	Axial load placed on a bolt or screw, usually measured in Newtons (N) or pounds (lb.)
TFFT	Turns from finger tight
Torque	The product of a force X lever arm length, usually measured in Newton-meters (Nm) or foot-pounds (lb-ft)
Torque angle	A tightening procedure where fitting is assembled to a precondition (finger tight) and then nut is turned farther a number of degrees to achieve its final position
Torque-tension	The relationship between assembly torque applied to a piece of hardware and axial load it induces in bolt or screw
Truck	A four-wheel highway/road vehicle weighing no less than 3400 kg (7500 lb.)
UCA	Upper cross auger
Untimed knife drive	Unsynchronized motion applied at cutterbar to two separately driven knives from a single hydraulic motor or two hydraulic motors
Washer	A thin cylinder with a hole or slot located in the center that is to be used as a spacer, load distribution element, or locking mechanism



# Predelivery Checklist

Perform these checks and adjustments prior to delivery to your Customer. **Adjustments are normally not required as the machine is factory-assembled and adjusted.** If adjustments are required, refer to the appropriate page number in this manual. The completed checklist should be retained by either the Operator or the Dealer.



## CAUTION

Carefully follow the instructions given. Be alert for safety related messages that bring your attention to hazards and unsafe practices.

Header Serial Number:

Float Module Serial Number:

### FD1 Series FlexDraper® / FM100 Float Module Predelivery Checklist – North America

✓	Item	Reference
	Check for shipping damage or missing parts. Be sure all shipping dunnage is removed.	—
	Check for loose hardware. Tighten to required torque.	<i>10.2 Torque Specifications, page 380</i>
	Check tire pressure (Transport/Stabilizer Option).	<i>6.2 Checking Tire Pressure – Transport and Stabilizer Wheels, page 135</i>
	Check wheel bolt torque (Transport/Stabilizer Option).	<i>6.3 Checking Wheel Bolt Torque – Transport and Stabilizer Wheels, page 136</i>
	Check knife drive box breather position.	<i>6.4 Checking Knife Drive Box, page 137</i>
	Check knife drive box oil level.	<i>6.4 Checking Knife Drive Box, page 137</i>
	Check float module gearbox oil level.	<i>6.5 Checking Oil Level in Header Drive Gearbox, page 139</i>
	Check hydraulic reservoir oil level before and after run-up.	<i>6.6 Checking Oil Level in Hydraulic Reservoir, page 140</i>
	Check knife drive belt(s) tension.	<i>6.7 Checking Knife Drive Belt Tension, page 141</i>
	Check if reel is centered between header endsheets (with header in full smile).	<i>6.9 Centering Reel on Double-Reel Header, page 144</i>
	Grease all bearings and drivelines.	<i>6.17 Lubricating Header, page 173</i>
	Check side draper tension.	<i>6.15 Adjusting Draper Tension, page 168</i>
	Check draper seal.	
	Check header float.	<i>6.11 Checking and Adjusting Header Float, page 148</i>
	Check wing balance.	<i>6.12.1 Checking Wing Balance, page 153</i>
	Check reel tine to cutterbar clearance.	<i>6.13.1 Measuring Reel Clearance, page 161</i>
	Check auger flighting to feed pan clearance.	<i>6.14 Adjusting Auger to Pan Clearance, page 165</i>
	Check knife hold-down adjustment.	<i>6.8 Checking Pointed Guard Hold-Downs, page 142</i>
	Check fitment of endshields.	<i>6.18 Checking and Adjusting Endshields, page 180</i>
	Check skid shoes are evenly adjusted at a setting appropriate for first crop.	—

**REFERENCE**

✓	Item	Reference
	Ensure feeder house variable speed is set to minimum.	—
	Ensure auto header height is calibrated and functioning correctly.	<i>7.1 Auto Header Height Control, page 185</i>
<b>Run-up procedure</b>		<i>9 Running up Header, page 369</i>
	Check hydraulic hose and wiring harness routing for clearance when raising or lowering header and reel.	—
	Check lights are functional.	—
	Check knife speed.	<i>9.1 Adjusting Knife Speed, page 371</i>
<b>Post run-up check. Stop engine.</b>		<i>9.2 Performing Post Run-Up Adjustments, page 374</i>
	Check knife sections for discoloration caused by misalignment of components.	<i>9.2.1 Adjusting Knife, page 375</i>
	Check feed draper tension.	<i>9.2.2 Checking and Adjusting Feed Draper Tension, page 376</i>
	Check for hydraulic leaks.	—
	Check that the manual storage case contains all of the required manuals.	<i>6.19 Checking Manuals, page 184</i>

**Date Checked:**

**Checked by:**



**MacDon Industries Ltd.**

680 Moray Street  
Winnipeg, Manitoba  
Canada R3J 3S3  
t. (204) 885-5590 f. (204) 832-7749

**MacDon, Inc.**

10708 N. Pomona Avenue  
Kansas City, Missouri  
United States 64153-1924  
t. (816) 891-7313 f. (816) 891-7323

**MacDon Australia Pty. Ltd.**

A.C.N. 079 393 721  
P.O. Box 103 Somerton, Victoria, Australia  
Australia 3061  
t.+61 3 8301 1911 f.+61 3 8301 1912

**MacDon Brasil Agribusiness Ltda.**

Rua Grã Nicco, 113, sala 404, B. 04  
Mossunguê, Curitiba, Paraná  
CEP 81200-200 Brasil  
t. +55 (41) 2101-1713 f. +55 (41) 2101-1699

**LLC MacDon Russia Ltd.**

123317 Moscow, Russia  
10 Presnenskaya nab, Block C  
Floor 5, Office No. 534, Regus Business Centre  
t. +7 495 775 6971 f. +7 495 967 7600

**MacDon Europe GmbH**

Hagenauer Strasse 59  
65203 Wiesbaden  
Germany

CUSTOMERS

**MacDon.com**

DEALERS

**Portal.MacDon.com**

Trademarks of products are the marks of their  
respective manufacturers and/or distributors.

Printed in Canada