



**MacDon**

# **FD1 Series FlexDraper<sup>®</sup> Combine Header with FM100 Float Module**

**Unloading and Assembly Instructions (North America)**

Supplement to 214406 Revision A

2018 Model Year

Original Instruction

*Featuring MacDon FLEX-FLOAT Technology™*

*The harvesting specialists.*

This supplement applies to 214406 Revision A – FD1 FlexDraper® Combine Header with FM100 Float Module Unloading and Assembly Instructions (North America).

***Purpose of this supplement***

FD145 headers require additional instructions for removing the endshields from shipping position and reinstalling in operating position.

***Instructions***

Insert this supplement into the Unloading and Assembly Instructions, after *Chapter 2.3: Removing Shipping Stands*.

Published May 2018.

## Removing Endshields from Shipping Position – FD145 Headers

This procedure applies to FD1 13.7 m (45 ft.) headers only. All other header sizes are shipped with the endshields in operating position.

1. Loosen nuts (A) and remove screws (B). Use slots in shipping channel to access nuts. Remove channel (C).
2. Remove bolt (D) at front of endshield.

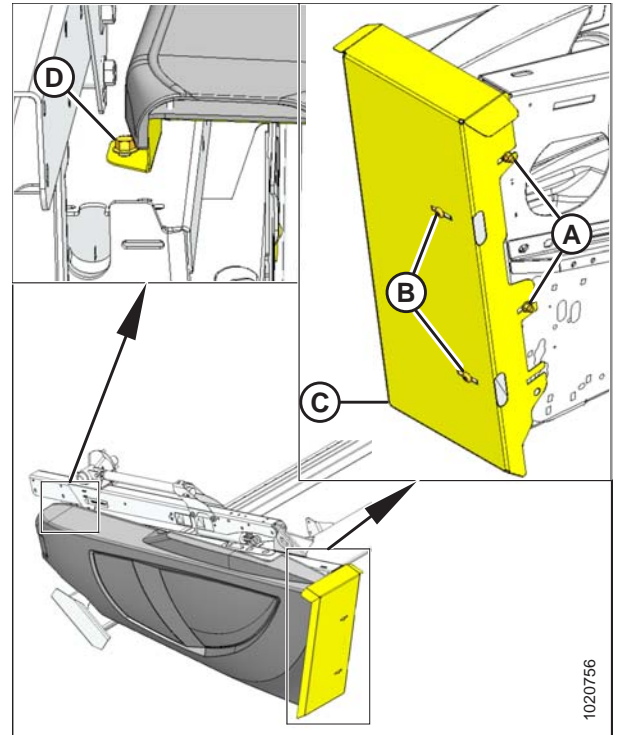

Figure 1. Left Endshield

3. Swivel endshield towards rear of header.

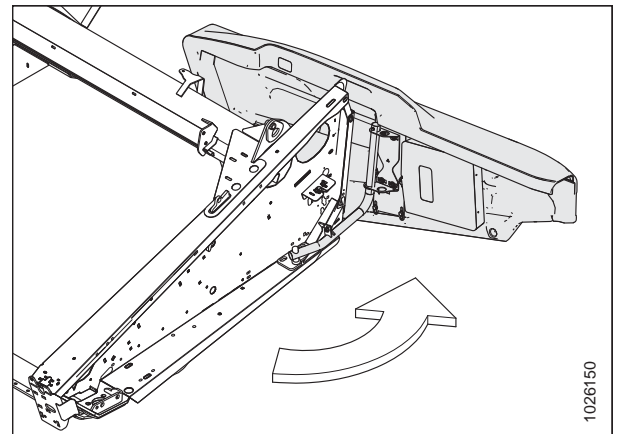
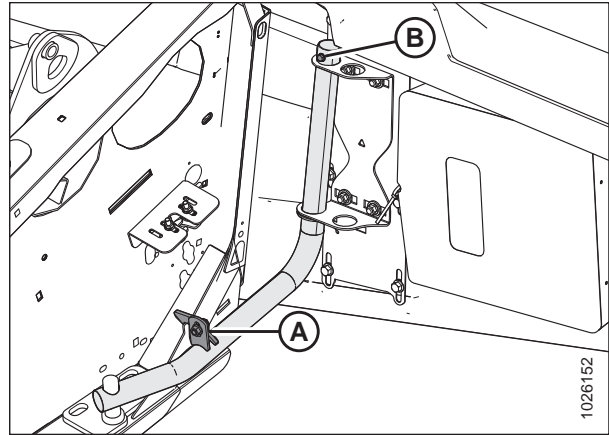

Figure 2. Left Endshield

4. Engage lock (A) to prevent endshield movement.
5. Remove self-tapping screw (B).
6. Slide endshield upwards and remove from hinge arm.

**NOTE:**

The inboard holes (position 2) on the endshield bracket are used for shipping position.



**Figure 3. Left Endshield**

7. Remove fasteners securing shipping brackets (A) to endshields and remove brackets. Discard fasteners and brackets.

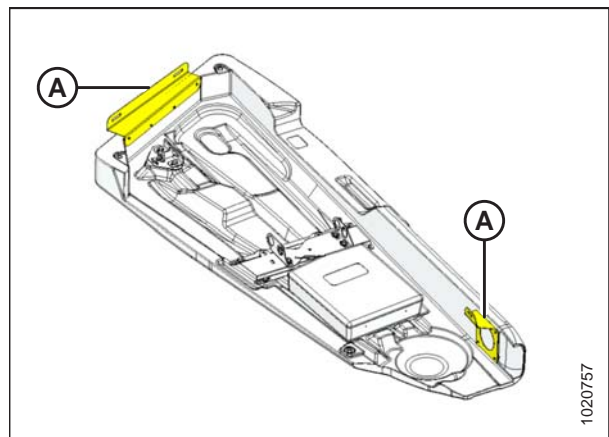

**Figure 4. Left Endshield**

8. Guide endshield onto hinge arm, using outboard holes (position 1) on bracket (C). Slowly slide the endshield downwards.
9. Install self-tapping screw (B).
10. Disengage lock (A) to allow endshield movement.

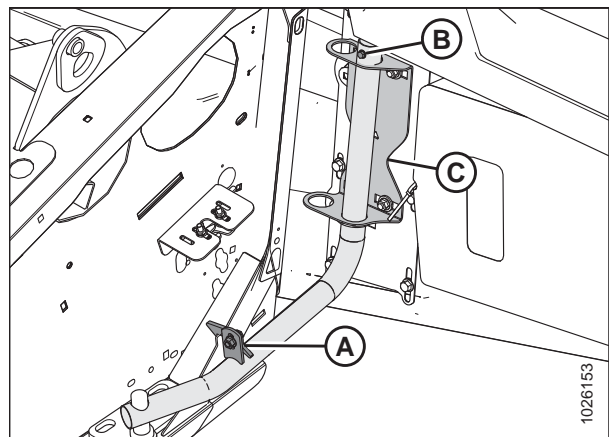

**Figure 5. Left Endshield**

11. Insert front of endshield behind hinge tab (A).
12. Swing endshield in direction (B) into closed position. Engage lock with a firm push.
13. Verify that endshield is locked.
14. Repeat above steps for opposite endshield.

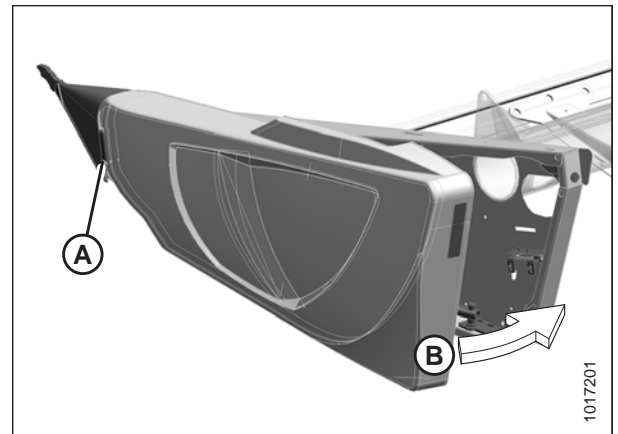

**Figure 6. Left Endshield**

15. On the outboard side of the right endsheet, remove shipping wire (A) securing divider rods (B) to the endsheet, and remove the divider rods from the shipping location.

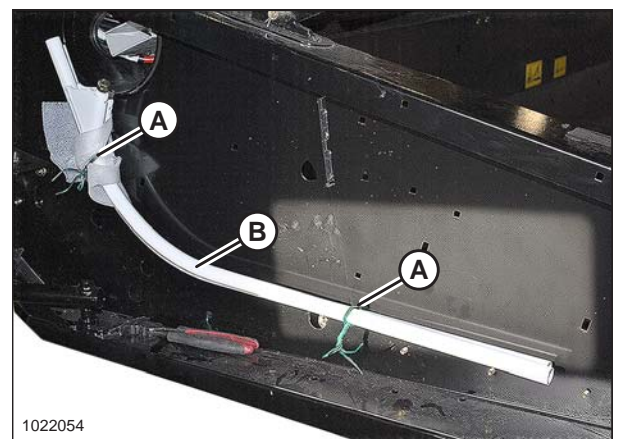

**Figure 7. Divider Rods in Shipping Location on Header Endsheet**

16. Store both crop divider rods (A) in bracket (B) as shown on the inboard side of the right side endsheet.

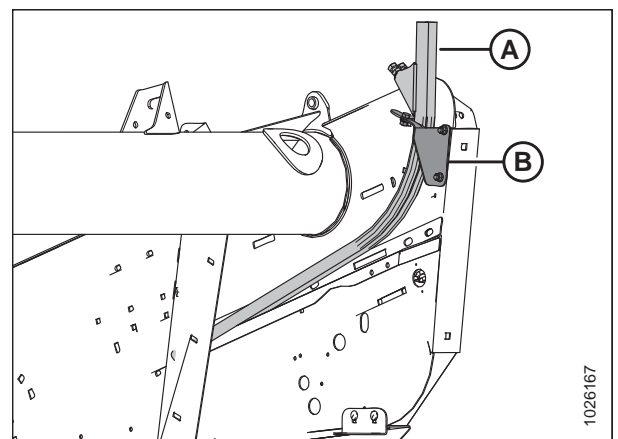

**Figure 8. Divider Rods in Storage Location**





**MacDon Industries Ltd.**

680 Moray Street  
Winnipeg, Manitoba  
Canada R3J 3S3  
t. (204) 885-5590 f. (204) 832-7749

**MacDon, Inc.**

10708 N. Pomona Avenue  
Kansas City, Missouri  
United States 64153-1924  
t. (816) 891-7313 f. (816) 891-7323

**MacDon Australia Pty. Ltd.**

A.C.N. 079 393 721  
P.O. Box 103 Somerton, Victoria, Australia  
Australia 3061  
t.+61 3 8301 1911 f.+61 3 8301 1912

**MacDon Brasil Agribusiness Ltda.**

Rua Grã Nicco, 113, sala 202, B. 02  
Mossunguê, Curitiba, Paraná  
CEP 81200-200 Brasil  
t. +55 (41) 2101-1713 f. +55 (41) 2101-1699

**LLC MacDon Russia Ltd.**

123317 Moscow, Russia  
10 Presnenskaya nab, Block C  
Floor 5, Office No. 534, Regus Business  
Centre  
t. +7 495 775 6971 f. +7 495 967 7600

**MacDon Europe GmbH**

Hagenauer Strasse 59  
65203 Wiesbaden  
Germany

**CUSTOMERS**

**MacDon.com**

**DEALERS**

**Portal.MacDon.com**

Trademarks of products are the marks of their  
respective manufacturers and/or distributors.

Printed in Canada