

**NOTE:**

Read your operator’s manual and complete all the preadjustment tasks before setting the header float.

**Step 1: Preadjustments**

- Park the combine on a level surface, and ensure the combine feeder house is level. Refer to your combine operator’s manual for instructions.
- Ensure combine tires are equally inflated.
- Adjust header so cutterbar is 154–254 mm (6–10 in.) off the ground.
- Set guard angle to mid-position (between reading **B** and **C** on center-link indicator [A]).
- Set the reel fore-aft to mid-position (between marker **5** and **6** on reel arm decal).
- Fully lower the reel and shut down the combine.
- Place both header float locks (B) in unlocked (lowered) position (right side float lock shown).
- If equipped, set stabilizer/transport wheels to the fully raised position.
- Ensure all accessories are installed. Added weight will affect float, wing balance, and performance.

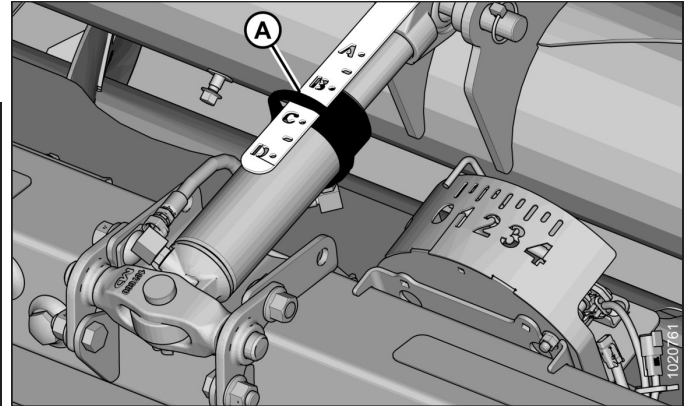

Figure 1: Center-Link

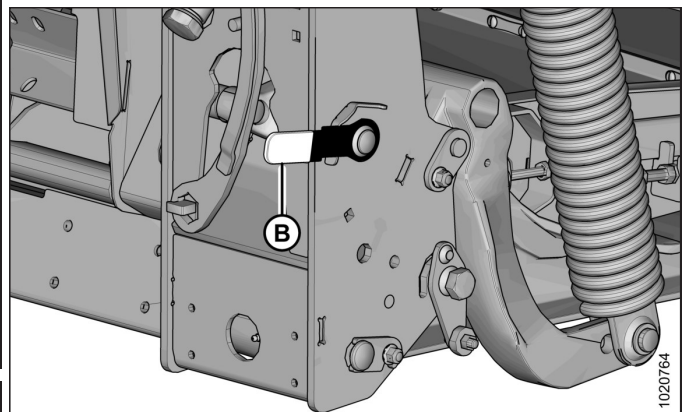

Figure 2: Float Unlocked – Right Side

**Step 2: Checking Header Float**

- Remove supplied torque wrench (C) from the storage position on the right side of the FM100 Float Module.
- Place the torque wrench onto float checking lever (D). Note the change in orientation of the wrench between the left side (Figure 3) and the right side (Figure 4).
- Push down on the torque wrench until bell crank (E) rotates forward, and continue pushing down until indicator (F) on the wrench reaches MAXIMUM reading and begins to decrease. Note the maximum reading.
- Repeat the previous three steps for the opposite side.
- Ensure torque wrench reading is the same on both sides, and the readings match the values in Table 1.1: Recommended Float Settings. If the readings don’t match the table values, proceed to Step 3: Setting Header Float.

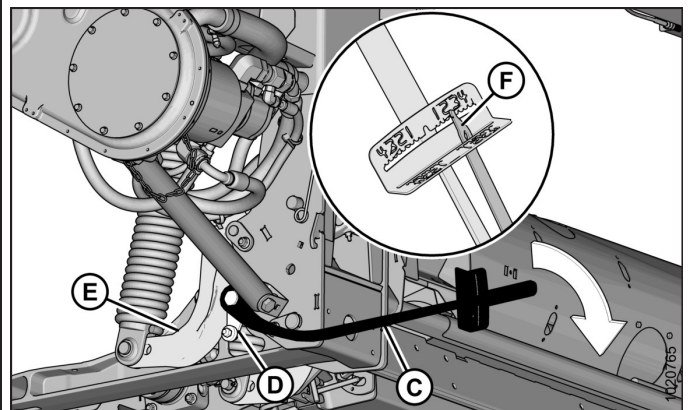

Figure 3: Checking Float – Left Side

Table 1.1: Recommended Float Settings

Header Size	Torque Settings	
	Cutting on the Ground	Cutting off the Ground
6.1, 7.6, 9.1, and 10.7 m (20, 25, 30, and 35 ft.)	1 1/2 to 2	2 to 2 1/2
12.2 and 13.7 m (40 and 45 ft.)	2 to 2 1/2	2 1/2 to 3

**NOTE:**

It may be necessary to set float values outside of these recommended ranges to accommodate crop and field conditions.

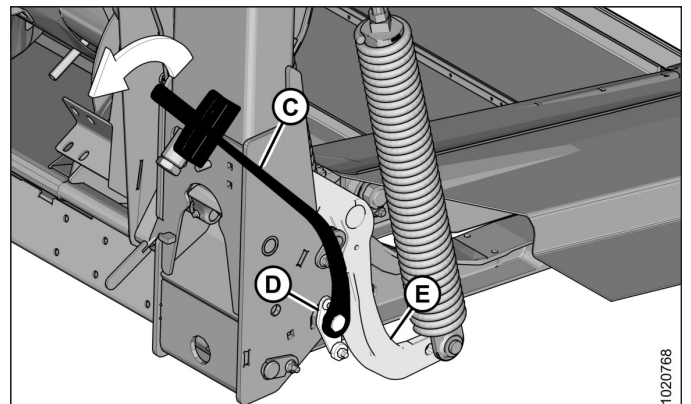

Figure 4: Checking Float – Right Side

### Step 3: Setting Header Float

- a. Before adjusting float, rotate spring locks (A) out of the way by loosening bolts (B). Turn each float spring adjustment bolt (C) an equal amount. Adjust the header float to match the values listed in Table 1.1: Recommended Float Settings.

**Increase float** (decrease header weight) by turning adjustment bolts (C) clockwise.

**Decrease float** (increase header weight) by turning adjustment bolts (C) counterclockwise.

- b. Check header float, refer to Step 2 Checking Header Float.
- c. When setting is complete, rotate spring locks (A) onto adjustment bolts (C). Tighten bolts (B) to secure spring locks (A).

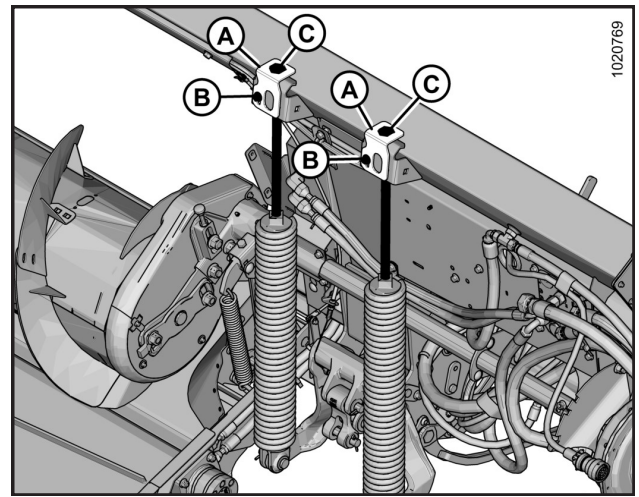

Figure 5: Float Adjustment Bolts – Left Side

Table 2.1: Recommended Fluids and Lubricants

Lubricant	Specification	Description	Use	Capacities
Grease	SAE multi-purpose	High temperature extreme pressure (EP) performance with 1% max molybdenum disulphide (NLGI Grade 2) lithium base	As required unless otherwise specified	—
		High temperature extreme pressure (EP) performance with 10% max molybdenum disulphide (NLGI Grade 2) lithium base	Driveline slip-joints	—
Gear Lubricant	SAE 85W-140	API service class GL-5	Knife drive box	2.2 liters (2.3 quarts)
			Main drive gearbox	2.5 liters (2.6 quarts)
Hydraulic Oil	Single grade transmission/hydraulic fluid (THF). Recommended viscosity: • 60.1 cSt @ 40 C • 9.5 cSt @ 100 C	Lubricant trans / hydraulic oil	Header drive systems reservoir	85 liters (22.5 US gallons)

Table 3.1: Break-In Inspections

Time	Item
First 5 Minutes	Check hydraulic oil level in reservoir (check after first run-up and after the hydraulic hoses have filled with oil).
First 5 Hours	Check for loose hardware and tighten to the required torque value. Check knife drive belts tension (check the tension periodically for the first 50 hours).
First 10 Hours	Check auger drive chain tension. Check knife drive box mounting bolts.
First 50 Hours	Change float module gearbox oil. Change float module hydraulic oil filter. Change knife drive box lubricant. Check gearbox chain tension. Check deck height adjustment.

Table 4.1: Ongoing Maintenance Intervals

Time	Service
Every 10 Hours (or Daily)	Check hydraulic hoses and lines for leaks. Check knife sections, guards, and hold-downs. Check tire pressure. Check link holder hooks. Lubricate knife (except in sandy conditions).
Every 25 Hours	Check hydraulic oil level. Grease knifeheads (one pump).
Every 50 Hours	Grease feed/center draper roller bearings. Grease driveline and driveline universals. Grease upper cross auger center support and U-joint.
<b>NOTE:</b> For service beyond 50 hours, refer to the D1 Series / FM100 Operator's Manual.	

Subject to change without notice