

INTRODUCTION

This manual contains information on the Model 801 adapter, which is required to allow attachment of the MacDon Model 960, 962 and 972 Harvest Headers to the New Holland 9030 and TV140 Bi-Directional Tractors.

NOTE: This supplement does not provide all the information required to operate the header. It must be used in conjunction with your Harvest Header and Tractor Operator's Manuals.

CAREFULLY READ ALL MANUALS TO BECOME FAMILIAR WITH RECOMMENDED PROCEDURES BEFORE ATTEMPTING TO UNLOAD, ASSEMBLE OR USE THE MACHINE.

This manual is divided into sections on: "Safety", "Attaching and Detaching the Header", "Operation" and "Maintenance/Service".

Use the Table of Contents and the Index to guide you to specific areas. Study the Table of Contents to familiarize yourself with how the material is organized.

Keep this manual handy for frequent reference and to pass on to new operators or owners. Call your dealer if you need assistance, information or additional copies of the manual.

NOTE: Right hand (R/H), and Left hand (L/H) designations are determined from the operators position, facing the header.

TABLE OF CONTENTS

INTRODUCTION	1
SERIAL NUMBER LOCATION	3
SAFETY	
Safety Alert Symbol.....	4
Signal Words	4
Safety Signs.....	5
ATTACHING & DETACHING	
Preparing the Tractor.....	6 - 9
Preparing the Adapter: Mounting Positions	10 - 15
Attaching Adapter to Tractor	16
Preparing the Header.....	17 - 20
Attaching Header to Tractor and Adapter	21 - 23
Detaching Header from Tractor and Adapter	24,25
Detaching Header and Adapter from Tractor	25
Attaching Header and Adapter to Tractor	26
OPERATION	
Header Controls	
Header Drive	27
Reel Speed Control.....	27
Draper Speed Control	27
Deck Shift (Triple Delivery Headers).....	27
Reel Height Control.....	27
Header/Adapter Height Control.....	27
Header Flotation	28
Header Levelling.....	28
Header Angle	29
MAINTENANCE/SERVICE	
Service Procedures.....	30
Greasing the Adapter.....	31
Hydraulic System	
Hydraulic System Safety	32
Hydraulic Hoses	32
Relief Pressure.....	33
Hydraulic Schematic	33
Electrical Schematic	34
Wheel & Tire Maintenance	35
TRANSPORT	36
TROUBLE SHOOTING.....	37 - 39
INDEX	40

SERIAL NUMBER LOCATION

Record the serial number in the space provided.

801 Adapter: _____

Plate is located on right side of adapter frame.



801 ADAPTER SERIAL PLATE

NOTE: When ordering parts and service, be sure to give your dealer the complete and proper serial number.

SAFETY

SAFETY ALERT SYMBOL



This safety alert symbol indicates important safety messages in this manual and on safety signs on the header.

This symbol means:
ATTENTION !
BECOME ALERT !
YOUR SAFETY IS INVOLVED !

Carefully read and follow the safety message accompanying this symbol.

Why is SAFETY important to you?

- 3 BIG REASONS
- ACCIDENTS DISABLE AND KILL
 - ACCIDENTS COST
 - ACCIDENTS CAN BE AVOIDED

SIGNAL WORDS

Note the use of the signal words DANGER, WARNING, and CAUTION with safety messages. The appropriate signal word for each message has been selected using the following guidelines:



DANGER – Indicates an imminently hazardous situation that, if not avoided, will result in death or serious injury.



WARNING – Indicates a potentially hazardous situation that, if not avoided, could result in death or serious injury. It is also used to alert against unsafe practices.



CAUTION – Indicates a potentially hazardous situation that, if not avoided, may result in minor or moderate injury. It is also used as a reminder of good safety practices.

SAFETY

SAFETY SIGNS

- The safety signs below appear on the adapter.
- Keep safety signs clean and legible at all times.
- Replace safety signs that are missing or become illegible.
- If original parts on which a safety sign was installed are replaced, be sure the repair part also bears the current safety sign.
- Safety signs are available from your Dealer Parts Department.

To install safety signs:

1. Be sure the installation area is clean and dry.
2. Decide on the exact location before you remove the decal backing paper.
3. Remove the smaller portion of the split backing paper.
4. Place the sign in position and slowly peel back the remaining paper, smoothing the sign as it is applied.
5. Small air pockets can be smoothed out or pricked with a pin.

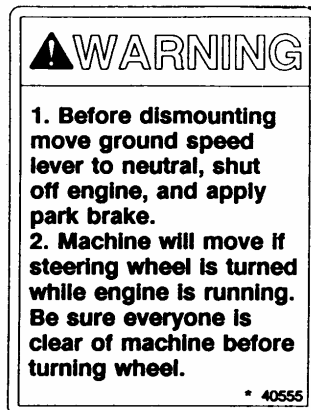
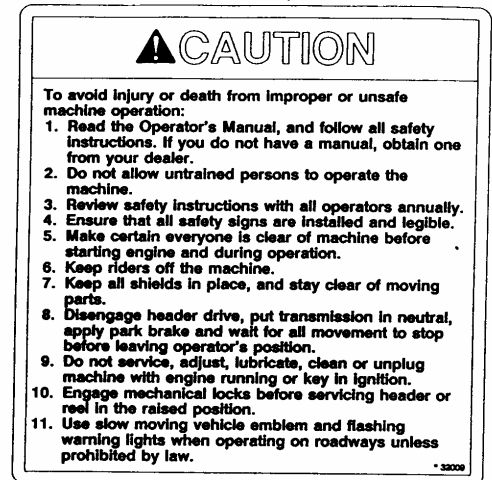
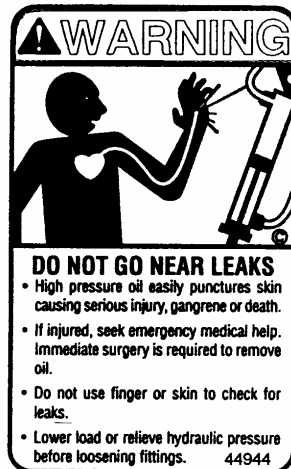
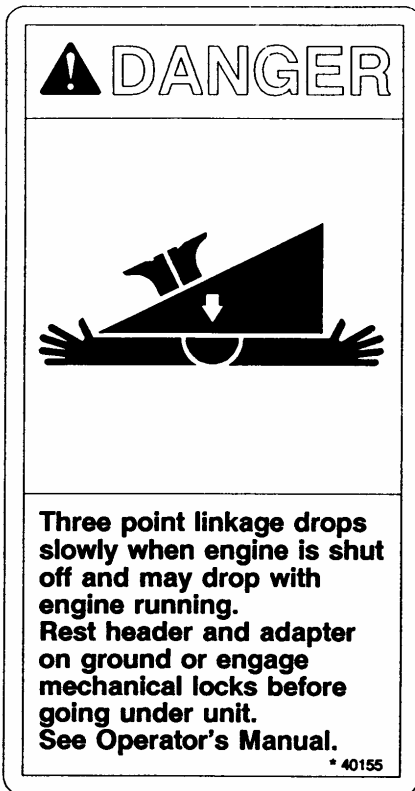

ATTACHING & DETACHING

PREPARING THE 9030 TRACTOR

NOTE: For TV140 Tractor, see page 8.

1. Check with your dealer to ensure tractor is properly equipped to carry header.

9030 TRACTOR REQUIREMENTS:

- Cab end 3-point hitch (ASAE S217.11 Category II) with New Holland #86011665 counterbalance valve and primary shuttle #86500467 to replace original shuttle #V90362 in lift circuit. This ensures 3-point hitch does not drop unless proper switch is activated.
- One hydraulic circuit with two 3/4 inch SAE female hydraulic quick couplers with open return to tank and 20 GPM flow for header drive.
- One hydraulic circuit with 1/2 inch SAE female hydraulic quick couplers with 4 GPM flow (with check valves in lift circuit) for reel lift.
- Seven terminal electrical receptacle (SAE J560b) with auxiliary switch in cab for warning lights and header control.

2. Set the hydraulic oil flow to the header at 20 gallons/minute. See your Tractor Manual.

If a flow meter is not available, turn flow control in tractor to maximum, then back it off 1/8 turn.

NOTE: Operating at maximum oil flow of 25 gallons per minute will reduce sickle drive life.

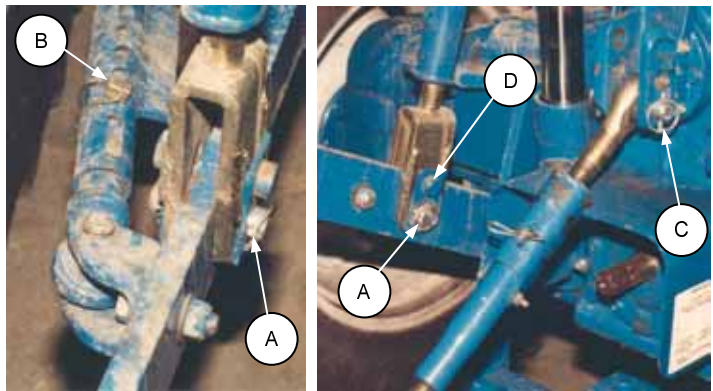

3-POINT HITCH SETTINGS: 9030 TRACTOR

3. Set the 3-point hitch:

9030 Tractor

- Stabilizers locked at (B) to prevent sideways movement of the lower links.
- Upper link set at lowest hole (C).
- Lift rod links at minimum length and in float position (with button (D) out, as shown, or with newer linkages use slotted hole).

IMPORTANT: Damage to 972 Transport wheel may occur with lift rod links set to other than minimum length.

- Lift rod links mounted at hole (A), **except 30' and 36' Headers**. For these headers, see below.

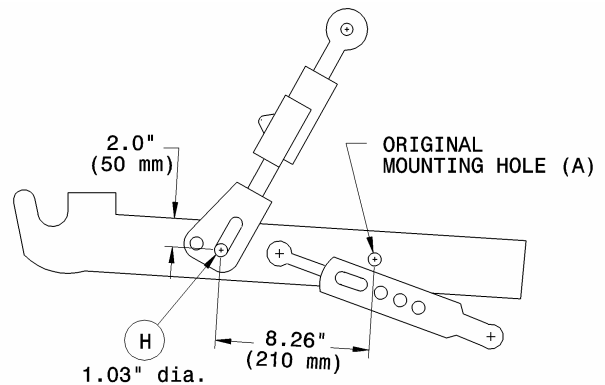

9030 TRACTOR LINKAGE MODIFICATION FOR 30' & 36' HEADERS

For 30' and 36' Headers on 9030 Tractor:

- Add a 1.03" diameter hole (H) to lower links at position shown below.
- Attach lift rod links to lower links at these new holes.

NOTE: When position (H) is used, lift rod links must be extended when attaching (or detaching) adapter to achieve adequate lowering of lower links. Return lift rod links to minimum length after attaching adapter.

IMPORTANT: To avoid machine damage, use this lift rod position only for the MacDon adapter and header. Always set lift rod links back to their original position before attaching any other implement.

ATTACHING & DETACHING

PREPARING THE 9030 TRACTOR (continued)

4. Install the header control panel in cab:

- Pull the floor mat back. Remove the "knock-out" plug from the 1 3/4" (45 mm) hole (D) in the floorboard. Hole is located 7" (180 mm) forward of floor bend-line, and 13" (330 mm) from the side of the console.
- Route the harness plug down through the hole. Pull the plug down between the hoses to the GREEN hydraulic couplers.
- Disassemble controller panel (E) from its mounting bracket and cover. Remove clamp from controller panel wiring harness and re-orient harness to point toward hole (D). Replace clamp. Position controller panel (E) even with the top of console. Align front of panel with edge of Rockshaft Position panel (F). Mark the mounting hole position and drill two 1/8" (3 mm) holes. Secure panel to console with two #10 x 1/2" self-tapping screws. Replace controller panel cover. *(Mounting bracket is used with TV140 tractor only.)*
- **IMPORTANT:** The auxiliary switch in cab must be on to operate header control panel. Consult your Tractor Operator's Manual for location of switch. If the tractor has no switch, ensure there is power to the center pin on the 7-pin connector when the key is ON.

NOTE: For Hydraulic Deck Shift Header, install deck shift switch (shipped with the header) in control panel as follows:

- Cut decal to expose third switch hole (G) in panel.
- Push switch into hole and attach wires from harness as shown. (The other loose plugs in harness are not used in this application.)
- When header is attached, check function of deck shift switch. Pressing left side of rocker switch should shift decks to the left. If pressing left side of rocker shifts decks to the right and vice-versa, exchange positions of the two green wires at the switch.

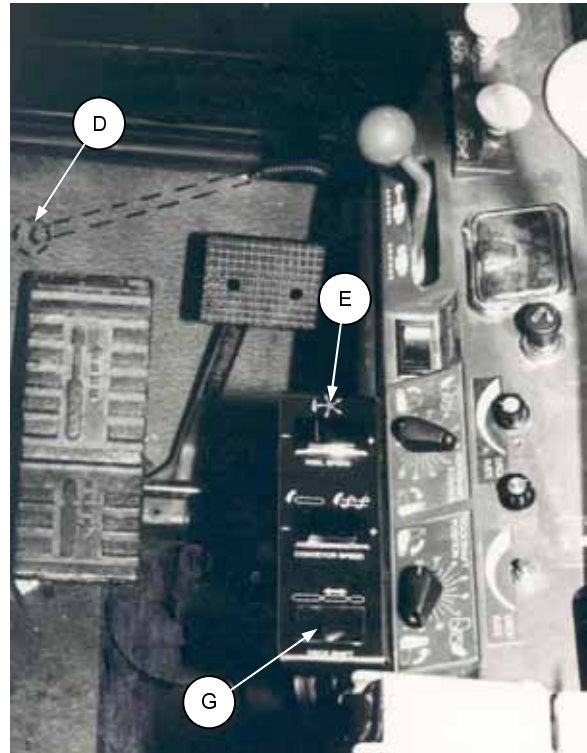

INSTALL HEADER CONTROL PANEL (9030)

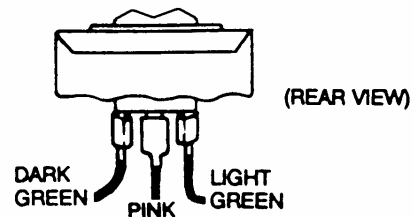

DECK SHIFT PADDLE SWITCH WIRING
(Hydraulic Deck Shift Headers)

ATTACHING & DETACHING

PREPARING THE TV140 TRACTOR

NOTE: For 9030 Tractor, see page 6.

1. Check with your dealer to ensure tractor is properly equipped to carry header.

TV140 TRACTOR REQUIREMENTS:

- Cab end 3-point hitch (ASAE S217.11 Category II) with one lift assist ram for headers (with reel) weighing less than 3100 lbs. and two lift assist rams for headers (with reel) weighing 3100 lbs. or more.
- One hydraulic circuit with two 3/4 inch SAE female hydraulic quick couplers (NH # 756171023) with open return to tank and 20 GPM flow for header drive.

NOTE: Do not use New Holland Auxiliary pump for header drive with 801 Adapter. Reel and draper drive will hesitate using this pump.

- One hydraulic circuit with 1/2 inch SAE female hydraulic quick couplers with 4 GPM flow (with check valves in lift circuit) for reel lift.
- Seven terminal electrical receptacle (SAE J560b) with auxiliary switch in cab for warning lights and header control.
- 16.9 x 38 tires.

2. Set the hydraulic oil flow to the header at 20 gallons/minute. See your Tractor Manual.

If a flow meter is not available:

- Adjust reel and draper speed controls to maximum flow.
- Increase flow in BLUE circuit until reel and/or drapers no longer increase in speed.
- Increase flow another 1/8 turn.

NOTE: Operating at maximum oil flow of 25 gallons per minute will reduce sickle drive life.

3. Set the 3-point hitch:

TV140 Tractor

- Remove standard upper link mount and install mount (A) supplied with adapter. Use existing spacers between mount and tractor and install 5/8 lockwashers under existing bolts. Attach upper link as shown.
 - Stabilizers locked at (B) to prevent sideways movement of the lower links.
 - Lift rod links at maximum length in float position, using slotted hole as shown at (C).
- IMPORTANT:** Damage to tractor tire may occur if lift rod links are not extended to maximum length.
- Lift rod links mounted at hole (C) in lower link arms.

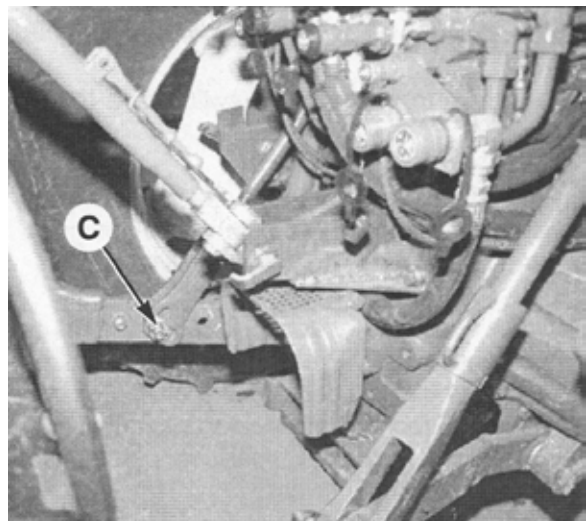
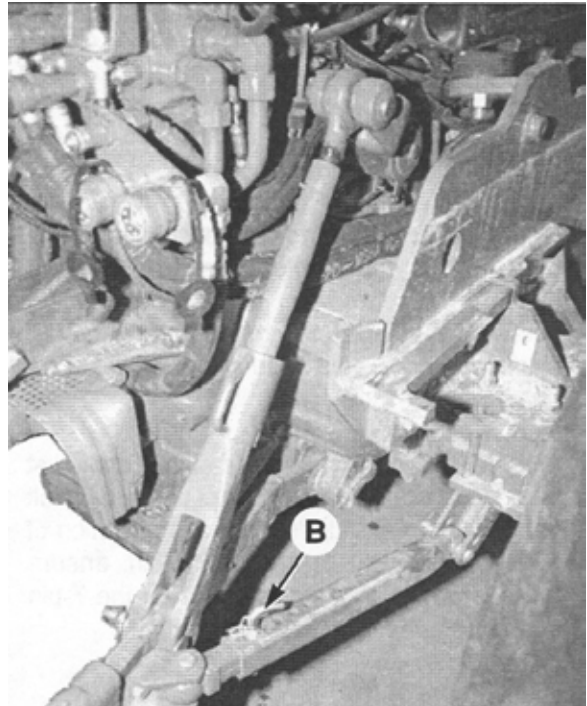
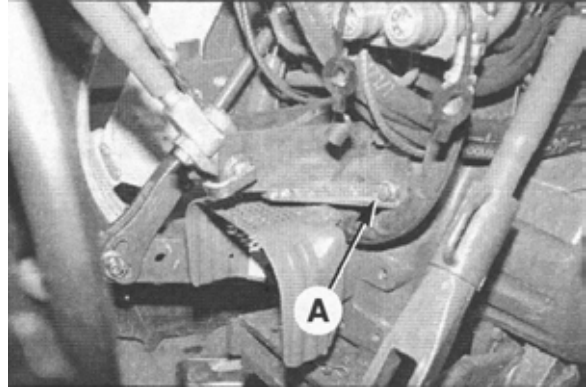

3-POINT HITCH SETTINGS: TV140 TRACTOR

ATTACHING & DETACHING

PREPARING THE TV140 TRACTOR (continued)

4. Install the header control panel in cab:

- Attach panel mount to left post using existing hardware at (A). Drill a 1/8" (3 mm) hole and install a #10 x 1/2 self-tapping screw at (B).
- Hang control panel on mount by engaging screw heads in slots (C).
- Remove rubber grommet (D) near windshield and slit it on the side to allow inserting panel wiring harness.
- Position harness so plug is near electrical connector.
- **IMPORTANT:** The auxiliary switch in cab must be on to operate header control panel. Consult your Tractor Operator's Manual for location of switch. If the tractor has no switch, ensure there is power to the center pin on the 7-pin connector when the key is ON.

NOTE: For Hydraulic Deck Shift Header, install deck shift switch (shipped with the header) in control panel as follows:

- Cut decal to expose third switch hole (G) in panel.
- Push switch into hole and attach wires from harness as shown. (The other loose plugs in harness are not used in this application.)
- When header is attached, check function of deck shift switch. Pressing left side of rocker switch should shift decks to the left. If pressing left side of rocker shifts decks to the right and vice-versa, exchange positions of the two green wires at the switch.

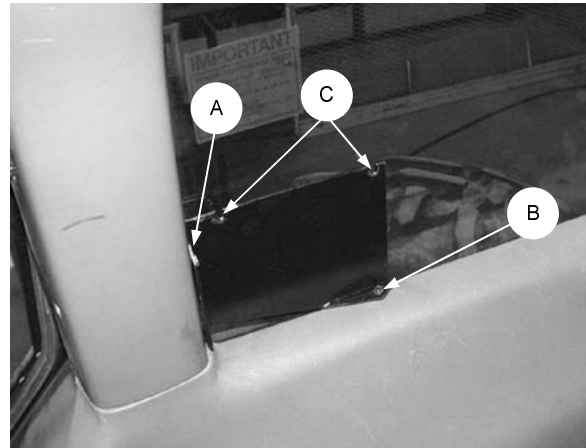

INSTALL PANEL MOUNT

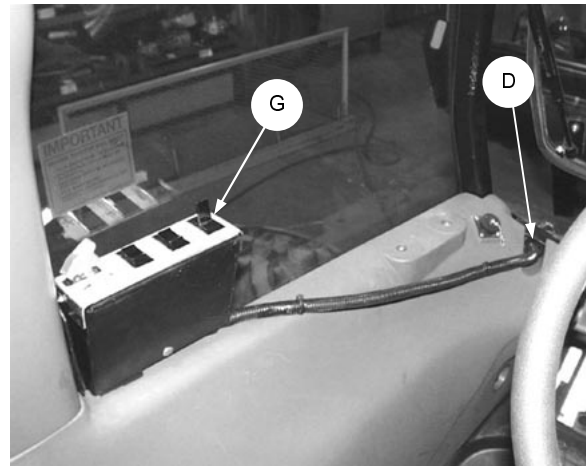

INSTALL HEADER CONTROL PANEL

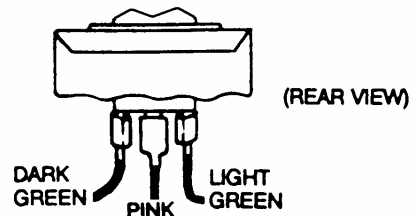

DECK SHIFT PADDLE SWITCH WIRING
(Hydraulic Deck Shift Headers)

ATTACHING & DETACHING

PREPARING THE ADAPTER

There are three positions on the Model 801 adapter for the tractor 3-point hitch mounts:

POSITION 1: Furthest left.

POSITION 2: Approximately 18 inches (450 mm) right of position 1.

POSITION 3: Furthest right.

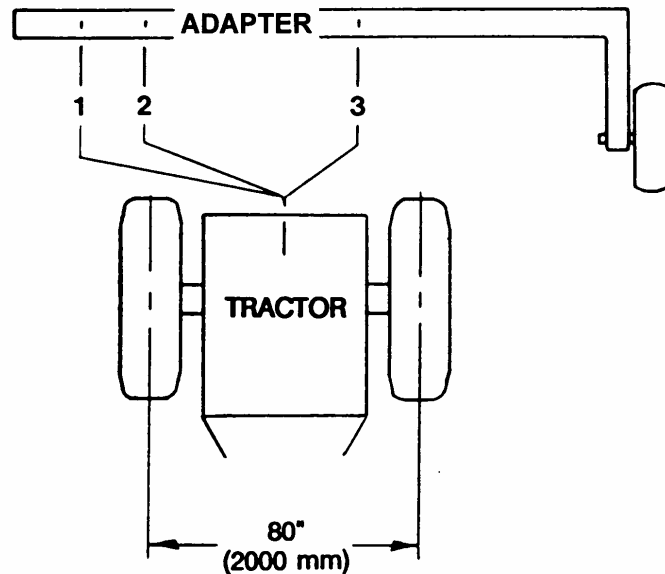

The illustrations on pages 11 to 14, (drawn approximately to scale), show the bi-directional tractor at each position for each header size. Maximum delivery opening width (distance between rollers) and clearances are shown with tractor tread width set at 80 inches center-to-center (2000 mm). This is the minimum tread width recommended for the New Holland loader. Changing tractor tread width can increase opening width and/or tractor tire-to-swath clearance. Keep in mind that crop may fan out as it leaves the header. Allow enough clearance to prevent tires running over the swath.

IMPORTANT: Not all mounting positions are recommended for every header size. The best tractor positions for center and end delivery are indicated for each header size. Swath delivery under the bi-directional tractor is limited to light crop conditions. Under tractor clearance can be increased by removing the tractor drawbar and drawbar rear support.

NOTE: Left end delivery opening sizes shown apply to both Manual Shift and Hydraulic Shift Headers. For Hydraulic Shift Headers, double swath opening size is limited to the lesser of the left and right end openings listed.

NOTE: See page 15 for instructions on positioning of the 3-point hitch mounts.

21' HEADER

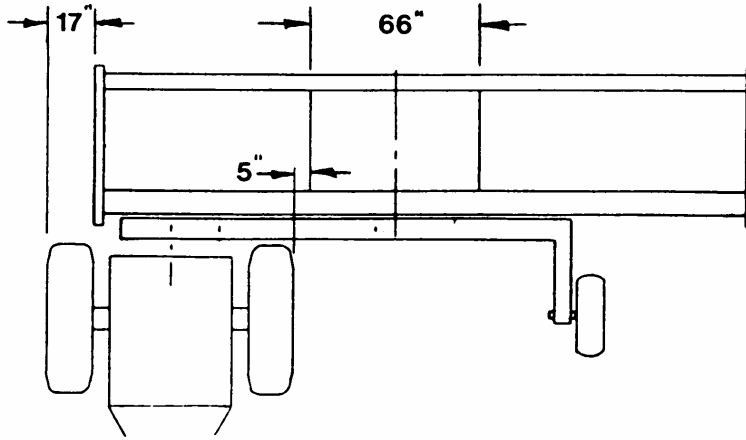

POSITION 1: Note tractor extends past end of header.

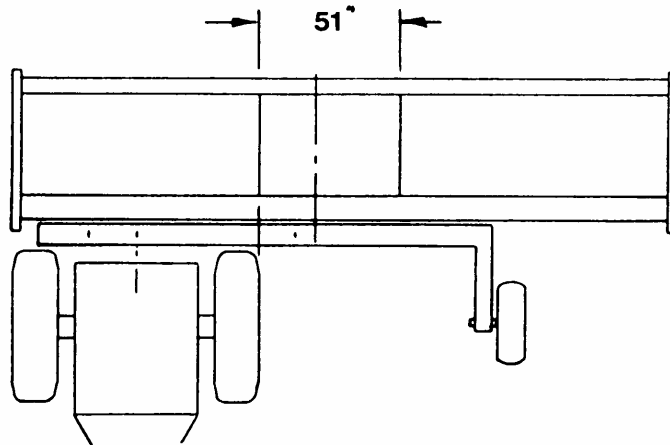

POSITION 2: Recommended for Center Delivery

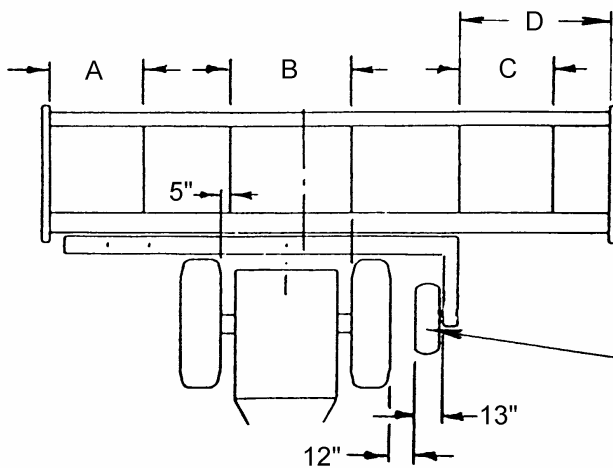

	Dim."A"	Dim."B"	Dim."C"	Dim."D"
960	42"	56"	42"	64"
	1067 mm	1422 mm	1067 mm	1627 mm
972	53"	56"		53"
	1346 mm	1422 mm		1346 mm

NOTE: Widest end delivery opening for 21' 960 header is 42" (1067 mm). This may not be suitable in heavy crop conditions.

Adapter wheel here for widest end delivery opening

POSITION 3: Recommended for End Delivery

25' HEADER

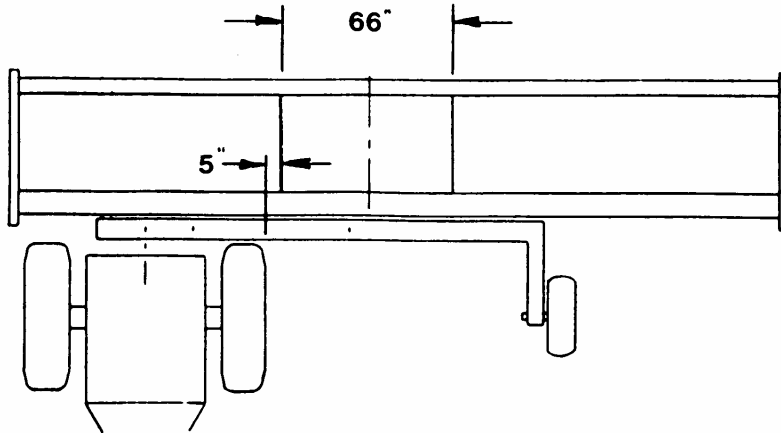

POSITION 1: Recommended for Center Delivery

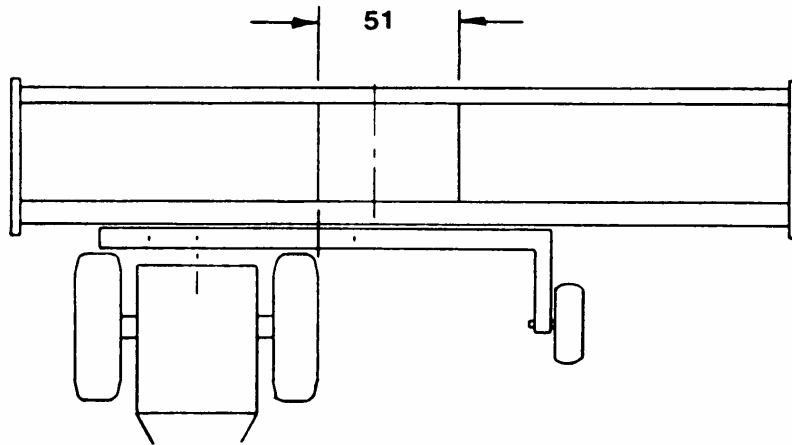

POSITION 2

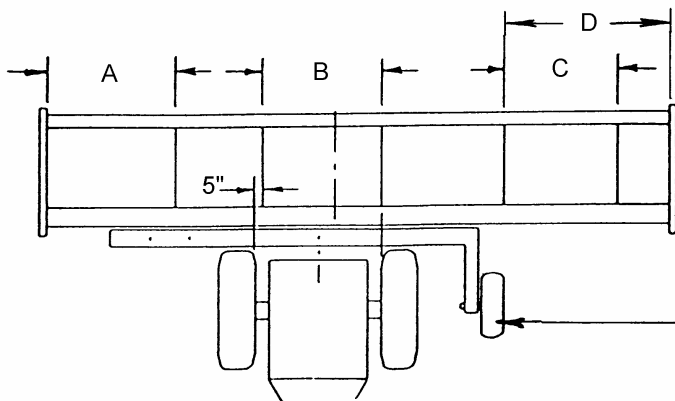

	Dim."A"	Dim."B"	Dim."C"	Dim."D"
960	61" 1550 mm	56" 1422 mm	54" 1372 mm	76" 1932 mm
972	64.3" 1633 mm	56" 1422 mm		54" 1372 mm

Move wheel to left of adapter leg to increase RH opening to 61"

POSITION 3: Recommended for End Delivery

30' HEADER

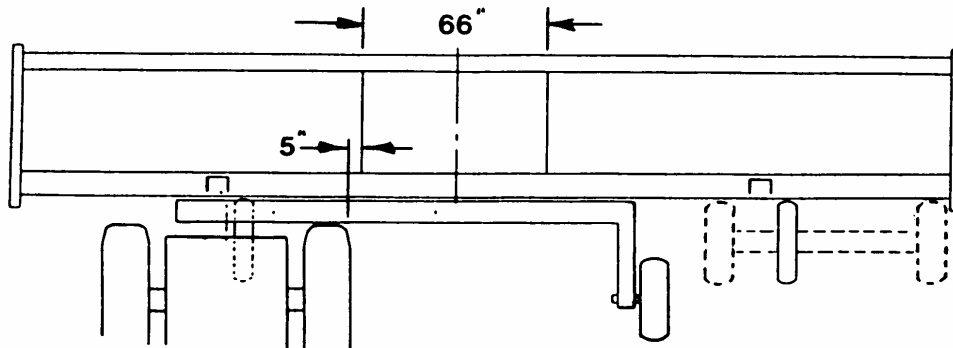

If 960/962 header has gauge wheels or 1993 or newer transport* wheels:

- Remove tractor drawbar & drawbar rear support.
- Adjust 3-point hitch lower link stabilizers to move tractor to right to maximize clearance to gauge wheel.
- **Manual Deck Shift Header:** Locate left gauge/transport wheel to right of header leg (shown).
- **Hydraulic Deck Shift Header:** Locate left gauge/transport wheel to left of header leg (not shown).
- Locate right gauge/transport wheel(s) to right of header leg.

* NOTE: 1993 or newer transport left wheel telescopes up into the header leg in field position. For transport package built prior to 1993, and for all 960 Triple Delivery Headers, remove left wheel, as it will interfere with the tractor.

POSITION 1: Recommended for Center Delivery

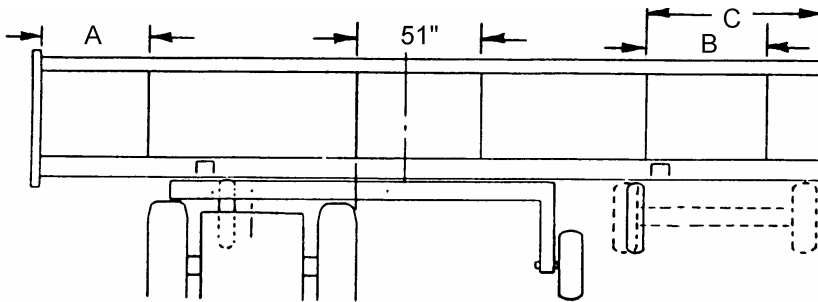

	Dim. "A"	Dim. "B"	Dim. "C"
960	48" 1219 mm	55" 1397 mm	
962	48" 1219 mm		
972	59" 1499 mm	55" 1397 mm	64.3" 1633 mm

If 960/962 header has gauge or 1993 or newer transport* wheels:

- Remove tractor drawbar & drawbar rear support.
- Adjust 3-point hitch lower link stabilizers to move tractor to left to maximize clearance to gauge wheel.
- Locate left gauge/transport wheel to right of header leg.
- **Standard Gauge Wheels:** Locate right wheel to left of header leg for widest end delivery opening.
- **Transport Gauge Wheels:** Locate right wheel axle to right of header leg. Store in raised position for end delivery.

* NOTE: 1993 or newer transport left wheel telescopes up into the header leg in field position. For transport package built prior to 1993, remove left wheel as it will interfere with the tractor.

POSITION 2

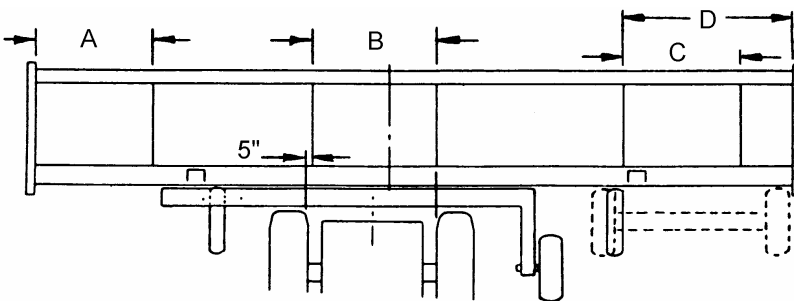

	Dim. "A"	Dim. "B"	Dim. "C"	Dim. "D"
960	55" 1397 mm	56" 1422 mm	55" 1397 mm	77" 1957 mm
962	55" 1397 mm	56" 1422 mm		
972	64.3" 1633 mm	56" 1422 mm		64.3" 1633 mm

If 960/962 header has gauge or transport wheels:

- Locate left gauge/transport wheel to right of header leg for widest end delivery opening.
- **Standard Gauge Wheels:** Locate right wheel to left of header leg for widest end delivery opening.
- **Transport Gauge Wheels:** Locate right wheel axle to right of header leg. Store in raised position for end delivery.

POSITION 3: Recommended for End Delivery

36' HEADER

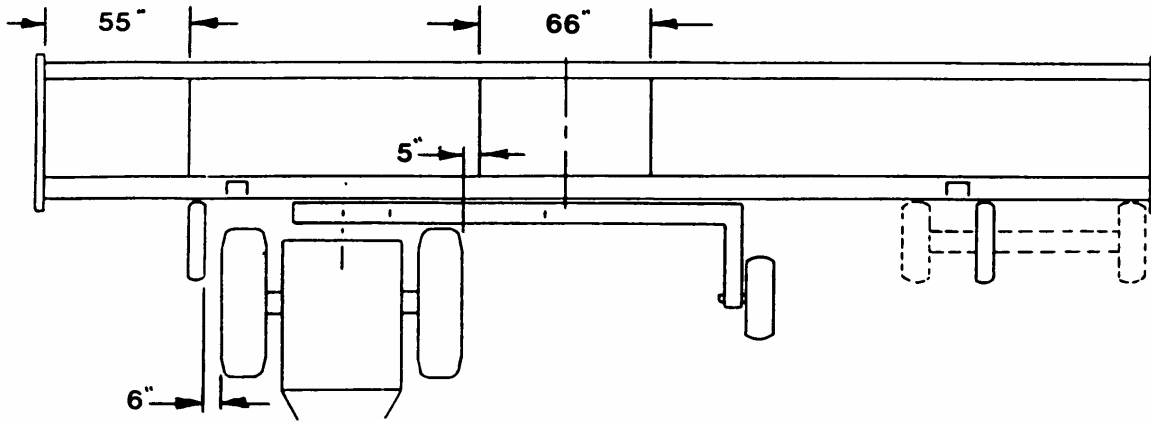

For 960/962 - Adjust 3-point hitch lower link stabilizers to move tractor to right to maximize clearance to gauge/transport* wheel.

- Reverse rim of left gauge/transport wheel and locate to left of header leg to maximize clearance to tractor tire.

- Locate right gauge/transport wheel(s) to right of header leg. (May be to left of leg if adapter wheel moved to left of adapter leg.)

* NOTE: Transport package must be 1993 or newer version, where left wheel telescopes up into the header leg in field position. For transport package built prior to 1993, remove left wheel, as it will interfere with the tractor.

POSITION 1: Recommended for Center Delivery

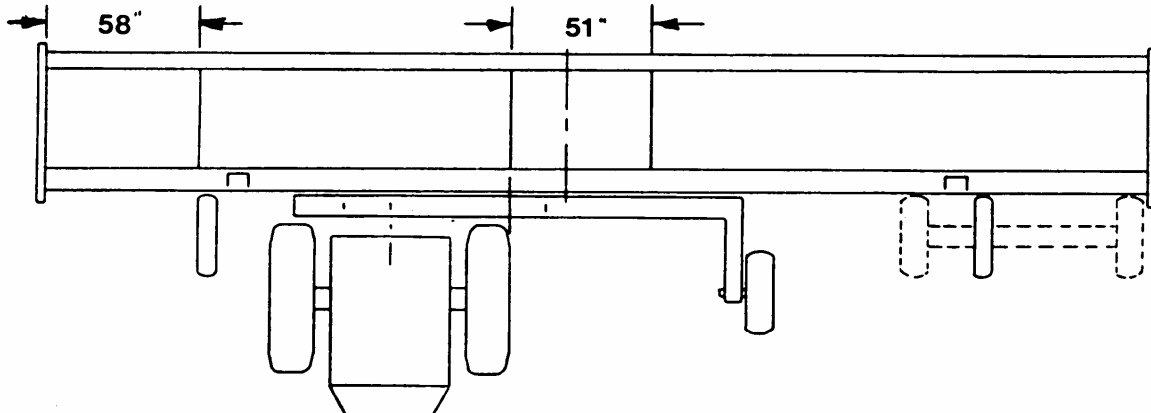

For 960/962 - Adjust 3-point hitch lower link stabilizers to move tractor to right to maximize clearance to gauge wheel.

- Locate left gauge/transport wheel to left of header leg.

- Locate right gauge/transport wheel(s) to right of header leg. (May be to left of leg if adapter wheel moved to left of adapter leg.)

POSITION 2

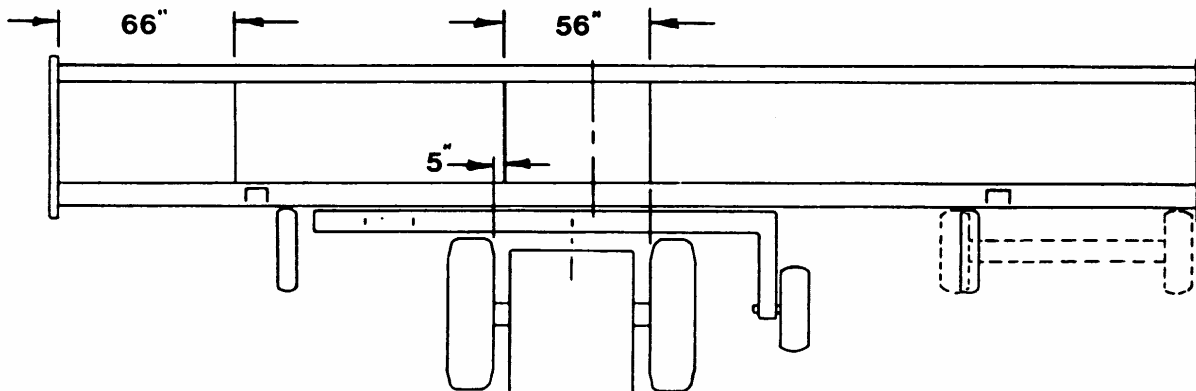

For 960/962 - Locate left gauge/transport wheel to right of header leg for widest end delivery opening.

- Locate right gauge wheel to left of header leg

- Locate right transport wheel beam to right of header leg. (May be to left of leg if adapter wheel moved to left of adapter leg.)

POSITION 3

ATTACHING & DETACHING

PREPARING THE ADAPTER

1. Move the 3-point hitch mounts to Position 1, 2 or 3 on the adapter frame.

(E) - Upper link mount (with hose guide)
 (F) - Lower link 2-bolt mount
 (K) - Lower link 3-bolt mount

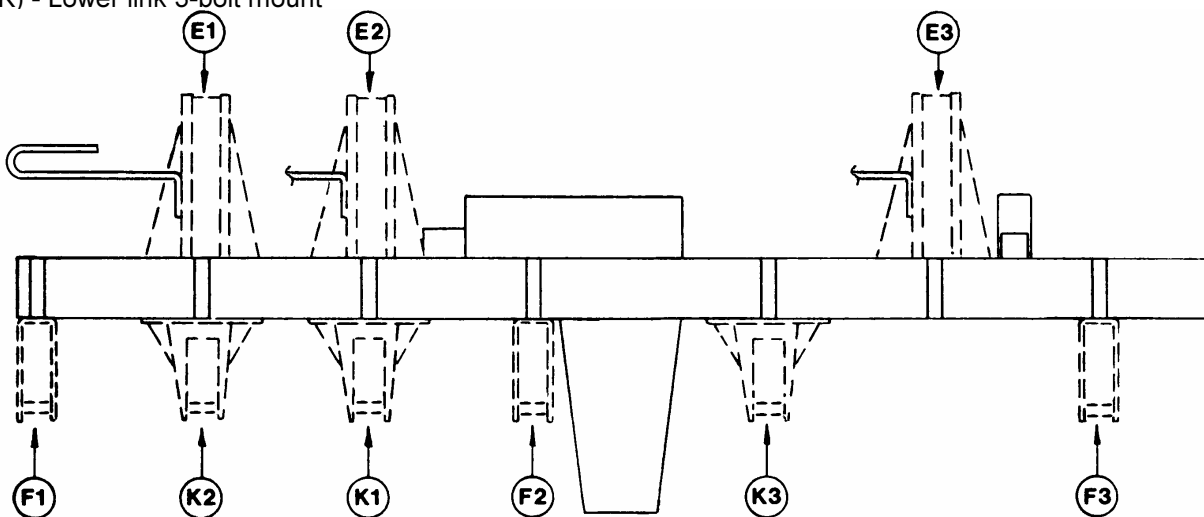

3-POINT HITCH MOUNT POSITIONS

For 9030 Tractor only:

- Install balls and cone shaped washers on lower link pins as shown at (L).
- Turn lower links 180° as shown at right, so that tapered edge of mount is rearward.

NOTE: After moving mounts to a different position, check all hydraulic hose and electrical harness routing and connections for new pinch or wear points.

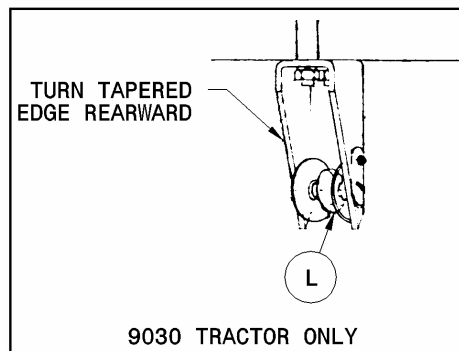

9030 TRACTOR ONLY

2. Install proper center link, depending on header as shown.

962 & 972 HEADERS
 CENTER LINK

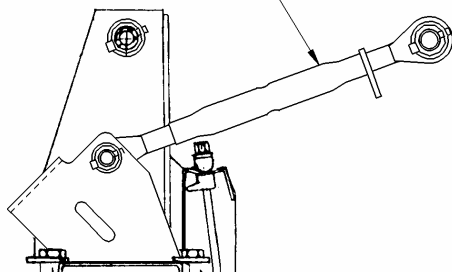

960 HEADER CENTER LINK

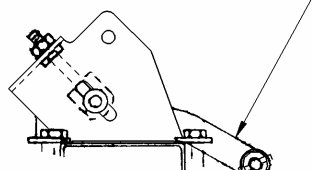

INSTALL CENTER LINK

3. Install collar (A) on hydraulic motor shaft, securing with two setscrews and jam nuts.

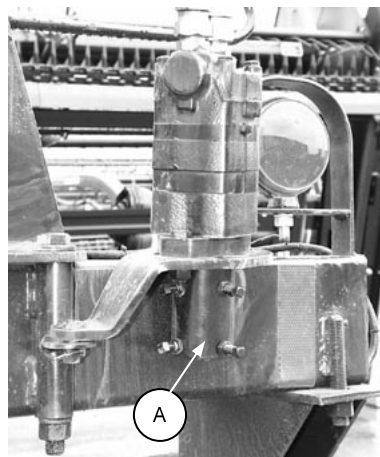

INSTALL COLLAR ON MOTOR SHAFT

ATTACHING & DETACHING

ATTACHING ADAPTER TO TRACTOR

1. **9030 Tractor:** With 3-point hitch lower links fully lowered and the top link raised to storage position, drive the tractor slowly towards the adapter until the lower link claw couplers are below the adapter lower mounts. The large claw openings make exact alignment unnecessary.

NOTE: For 30' and 36' Headers with Pick-Up Reel where tractor lift rod links have been repositioned to new hole in lower links (see page 6), extend lift rod links to allow linkage to lower further.

Raise the lower links using the hydraulic lift switch until claw couplers engage the ball bushings. An audible click will be heard as the self-locking latches engage. Stop engine and remove key.

2. **TV140 Tractor:** With 3-point hitch lower links fully lowered and the top link raised to storage position, drive the tractor slowly towards the adapter until tractor lower ball joints are just behind the adapter lower mount pins. See Tractor operator's Manual for hook-up procedure.
3. Attach top link to adapter at (C).

4. Identify 3/4 inch PRESSURE and RETURN couplers on tractor: Return coupler is connected to a single larger hose. For 9030 Tractor, pressure coupler is attached to two smaller hoses, one of which is routed to BLUE-EXTEND coupler. For TV140 Tractor, pressure coupler is attached to a steel line that is routed to BLUE-RETRACT coupler.

Attach quick coupler (R) to the tractor RETURN coupler.

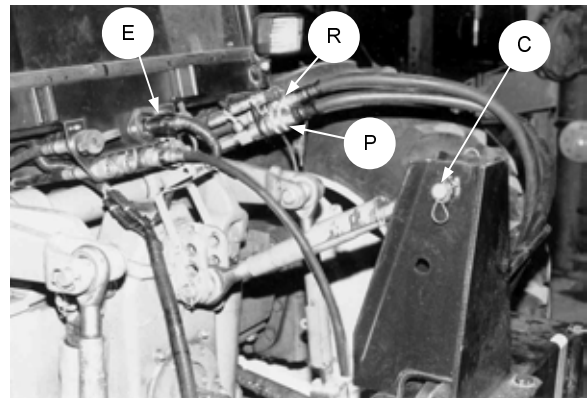

HYDRAULIC & ELECTRICAL CONNECTIONS
(9030 SHOWN)

IMPORTANT: Coupler (R) comes from the tee fitting on top of the adapter, and must be attached to the RETURN coupler on the tractor. FAILURE TO PROPERLY CONNECT THIS COUPLER MAY DAMAGE SICKLE DRIVE MOTOR. Coupler (R) has a black plastic tie fastened to it. To ease identification of mating couplers, attach the other black tie (supplied) to the tractor RETURN coupler.

Attach quick coupler (P) to the tractor PRESSURE coupler.

5. Attach 7 terminal plug from header lights wiring harness into tractor at (E).
NOTE: Be sure that harness is routed behind top link storage support to prevent pinching harness when header is raised.
6. Attach header control harness plug (F) into harness from control panel installed in cab. See "Preparing the Tractor".

ATTACHING & DETACHING

PREPARING THE HEADER

1. **960 & 962 Headers:** Attach lift linkage supports (supplied with adapter package) to lower header legs with 5/8 locknut at (A).
2. **972 Header:** Attach lift linkage supports (B) (supplied with adapter package) to lower header legs with 5/8 x 1 1/2 carriage bolts, lockwashers and nuts (bolt heads inside). Attach center section of wear plate (C) to cutterbar at delivery opening. Longer guard bolts are positioned at the correct locations.

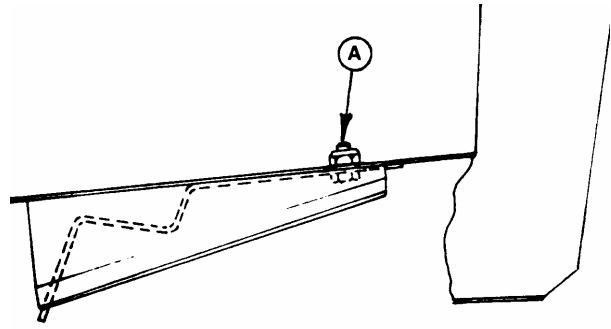

ATTACH LINKAGE SUPPORTS
TO HEADER LEGS: 960 & 962

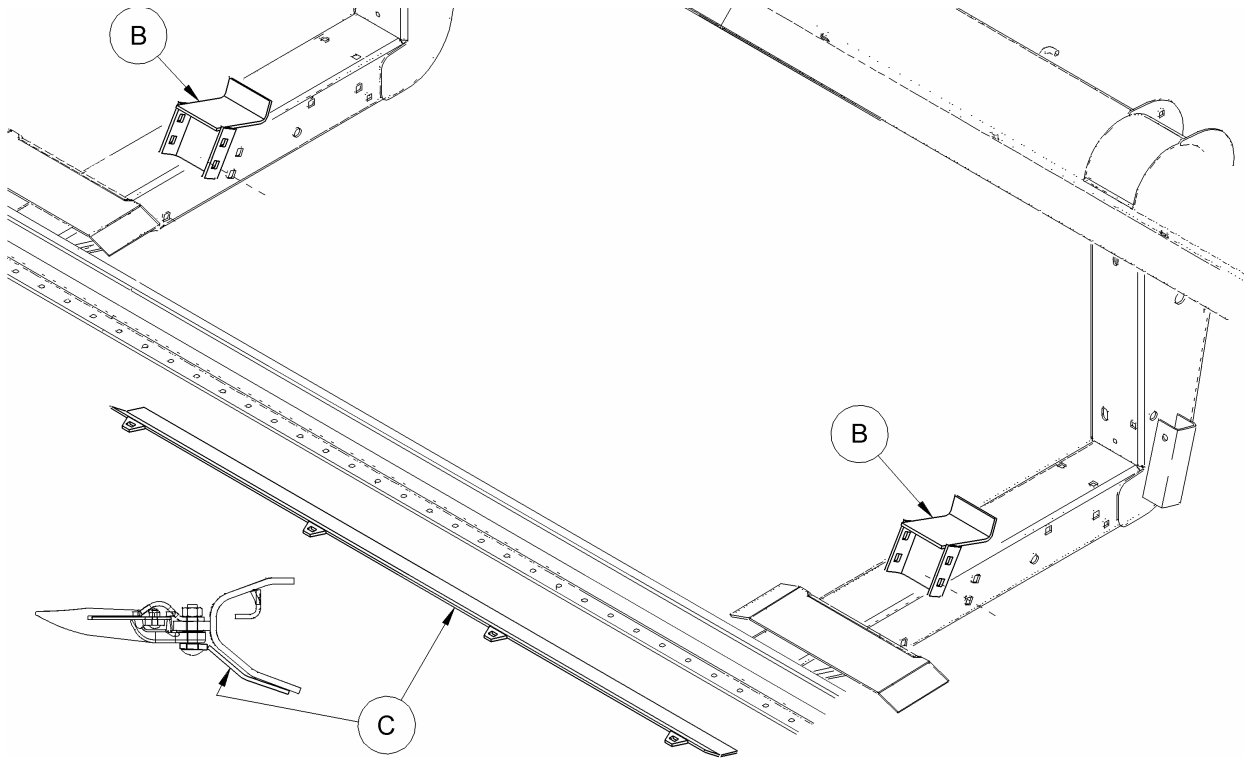

ATTACH LINKAGE SUPPORTS AND WEAR BAR: 972 HEADER

NOTE: For 962 & 972 Headers, the sickle drive assembly at left end sheet and drive shaft along left side of back tube must be in "Combine" configuration. For 962 Headers, this is the more forward of two available positions. For 972 Headers it is the lower of the two positions. If conversion from "Windrower" configuration is necessary, for 962 Headers follow the conversion instructions in the Header Operator's manual. For 972 Headers order the following conversion kit:
21' – B2624, 25' – B2625, 30' – B2626, 36' – B2627. Instructions are provided with the kit.

ATTACHING & DETACHING

PREPARING THE HEADER (continued)

3. **All Headers:** Install torque arm (D) on bearing mount at inboard end of header drive shaft. Use longer bolts provided (1 ¼ inch) and existing nuts.

960 Header only: Remove existing driveline shield and replace with shield (E) using existing hardware. Due to tolerances on shaft position, it may be necessary to flip bearing and place lock collar on opposite side to that shown in illustration to allow torque arms on header and adapter to align.

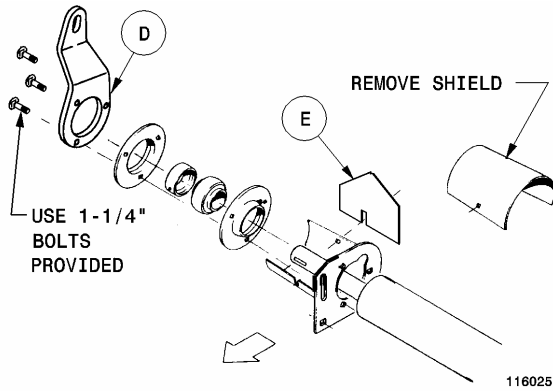

960 HEADER MOUNTED TORQUE ARM
36' SHOWN

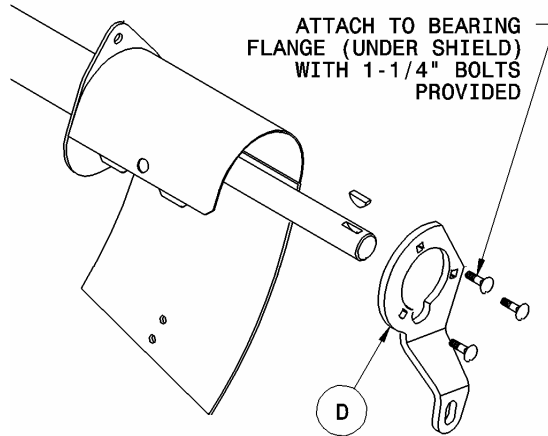

962/972 HEADER MOUNTED TORQUE ARM

For 21' and 25' 960 Headers: Drill holes in bearing mount and its mating bracket on back tube as shown to allow positioning drive shaft further forward for installation of large sickle drive pulley at left end.

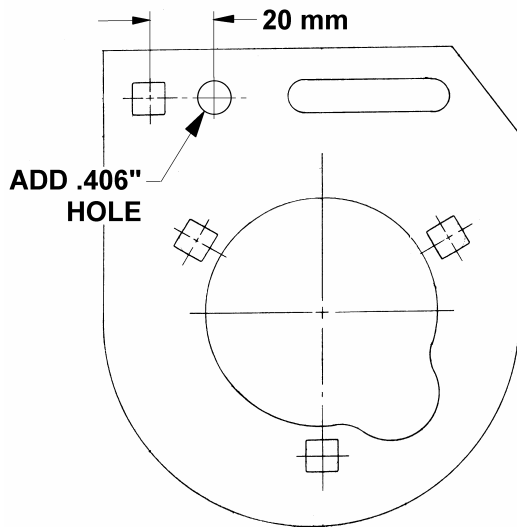

ADD HOLE TO BEARING MOUNT
21' & 25' 960 HEADERS ONLY

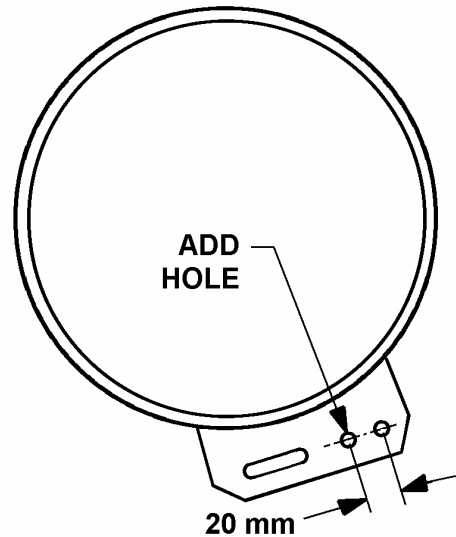

ADD HOLE TO FRAME BRACKET
21' & 25' 960 HEADERS ONLY

ATTACHING & DETACHING

PREPARING THE HEADER (continued)

4. Attach hose with 1/2 NPT male quick coupler (supplied with adapter package) to reel lift hose or line on header.
5. Move the mount for the reel drive couplers to the position shown:

21', 25', and 30' 960 headers & all 962 headers: Remove mounting plate (F) from side of header R/H leg and reposition on top of frame tube, using support (G) (shipped with adapter package).

36' 960 header only: Turn plate (F) 180°, so couplers point to the left end of the header instead of the right. (Support (G) is not used for 36' 960.)

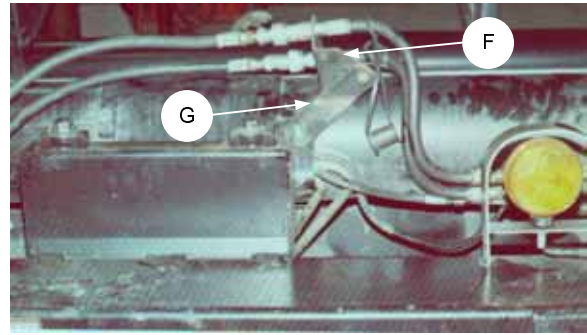

MOVE REEL DRIVE COUPLERS
21', 25', 30' 960 & ALL 962 HEADERS

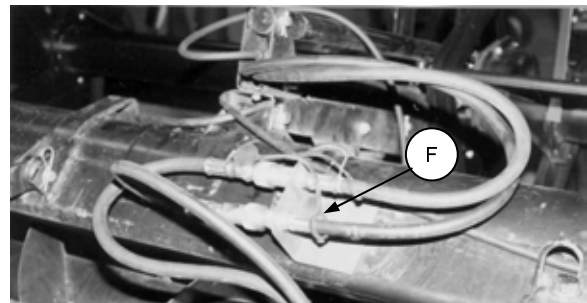

MOVE REEL DRIVE COUPLERS - 36' 960

972 headers with 2 reel arms: Remove holder (D) from side of header R/H leg. Attach support (E) (shipped with adapter package) to header leg using 3/8 x 1 carriage bolts and flange nuts. Reposition couplers on holder (D) as shown and secure on support (E) using existing hardware.

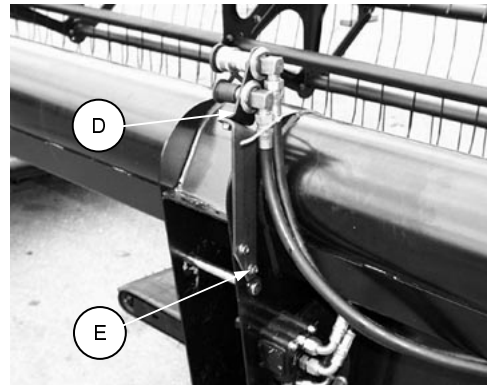

MOVE REEL DRIVE COUPLERS – 972 2-ARM

972 headers with 3 reel arms: Remove plate (C) from side of header R/H leg and relocate to channel under header tube as shown.

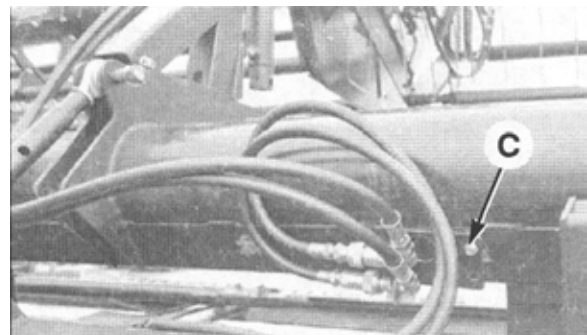

MOVE REEL DRIVE COUPLERS – 972 3-ARM

ATTACHING & DETACHING

PREPARING THE HEADER (continued)

6. **960/962 Manual Deck Shift Headers:** Release draper return hose (with blue male coupler) from hose clamp (H) at header L/H leg.

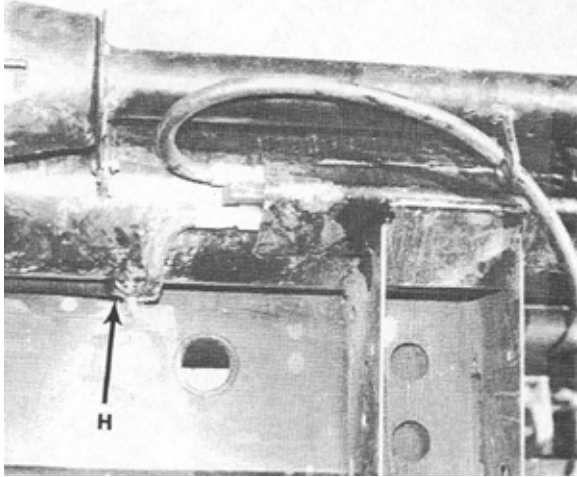

RELEASE HOSE FROM CLAMP -
MANUAL DECK SHIFT HEADERS
(driveline adapter shown is not used
in this application)

- 960 Hydraulic Deck Shift Headers:** Release draper pressure hose (with orange female coupler) from hose clamp (K). Pull draper return hose (with blue male coupler) out from behind short hose.

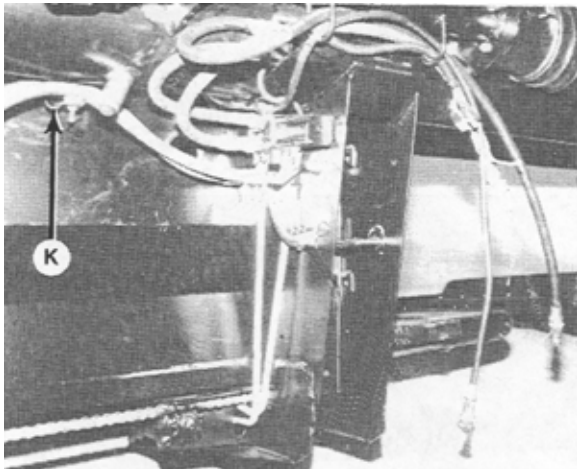

RE-ROUTE DRAPER HOSES -
HYDRAULIC DECK SHIFT HEADERS
(driveline adapter shown is not used
in this application)

7. **962 & 972 Headers:** Bolt the sheet metal pulley (A) provided with the adapter on the sickle drive pulley at the left end sheet, using three 3/8 x 1 bolts with lock washers.

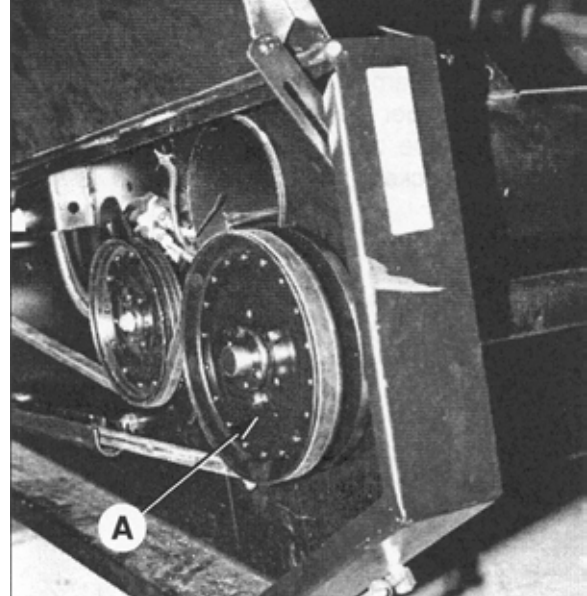

INSTALL SICKLE DRIVE PULLEY - 962 & 972

8. **960 Headers:** Disassemble sickle drive pulley, tightener bracket and upper belt guide at left end sheet. Install new components supplied with adapter, reusing bearing support plate, bearing and flanges. **21' & 25':** Move drive shaft to new forward position. See page 18.

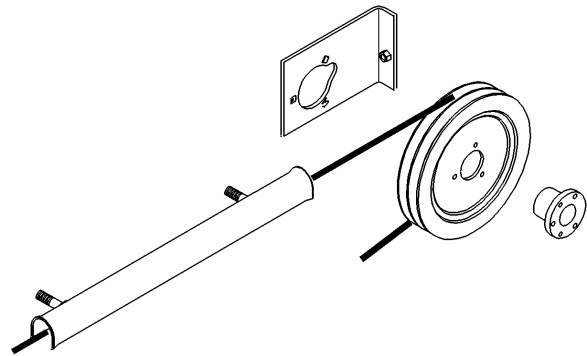

REPLACE SICKLE DRIVE PULLEY, BELT,
TIGHTENER & BELT GUIDE - 960 HEADER

9. **972 Headers with Transport Option:** To avoid damage to transport wheel, do not use the highest field position setting with this adapter.

ATTACHING & DETACHING

ATTACHING HEADER TO TRACTOR AND ADAPTER

1. **NOTE:** Choose an area that is as level as possible.

For headers without gauge wheels, be sure header stand is secure in the down position (A).

For headers with gauge wheels, block both wheels front and rear, and be sure gauge wheel pins are in stand position (L), both sides, to support rear of header.

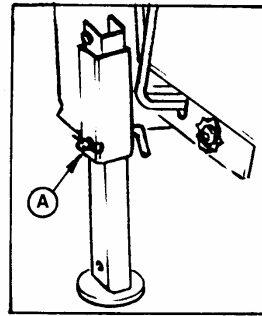

HEADER STAND

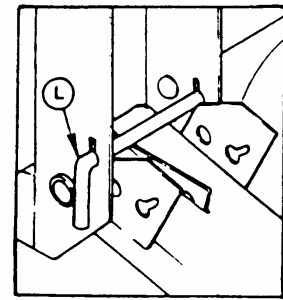

GAUGE WHEELS

IMPORTANT: Be sure linkage supports are attached to header lower legs. See "Preparing the Header", page 17.

- 2.



CAUTION: Be sure area is clear of bystanders, then start engine.

Fully retract 3-point hitch cylinders.

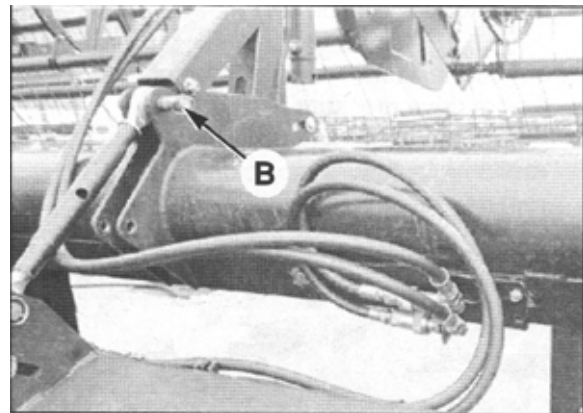

INSTALL CENTER LINK – 962 & 972 HEADERS

3. Slowly drive tractor forward so that adapter lift linkage enters header legs. Continue to drive slowly forward until linkage contacts support plate in the lower header leg, and header nudges forward. Stop engine and remove key.

4. Install center link (B) from adapter to header. Adjust length of link if required. See "Header Angle" in Operation section. See page 15 for attachment of center link to adapter.

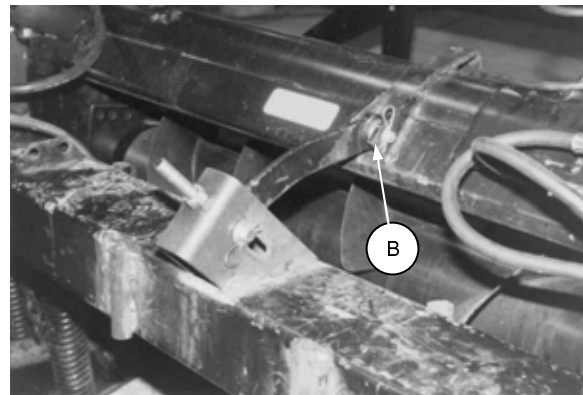

INSTALL CENTER LINK – 960 HEADER

5. Check that bottom of linkage (D) is properly engaged in header leg, contacting support plate (E).

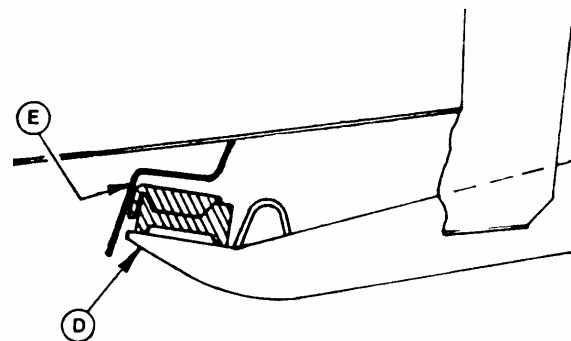

CHECK FOR PROPER ENGAGEMENT

ATTACHING & DETACHING

ATTACHING HEADER TO TRACTOR AND ADAPTER (continued)

6. Slide hydraulic motor onto header drive shaft engaging torque arm pin into header-mounted torque arm at (E). Secure with lynch pin. Tighten collar setscrews and jam nuts.
7. Connect the electrical wiring harness (F) near left-hand spring tower.
8. Make the five hydraulic connections; matching colour coded couplers as follows:
 - Four connections from header to adapter:
 - draper drive pressure (orange) (O)
 - draper drive return (blue) (B)
 - reel drive pressure (no colour code) (P)
 - reel drive return (yellow) (Y)

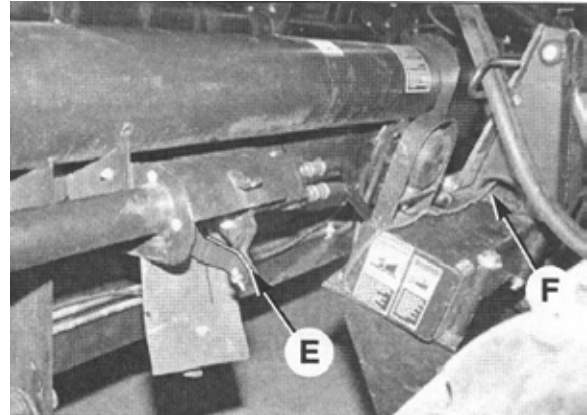

CONNECT MOTOR & WIRING HARNESS

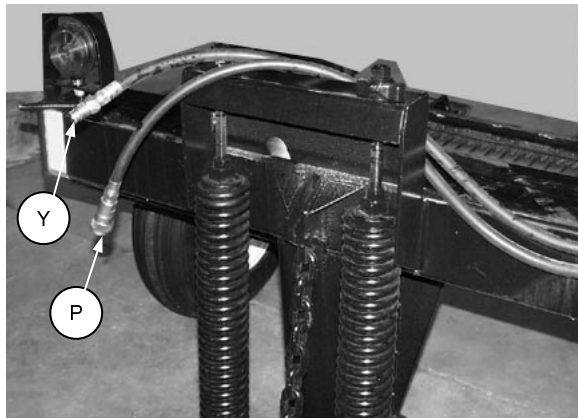

CONNECT REEL DRIVE HYDRAULICS

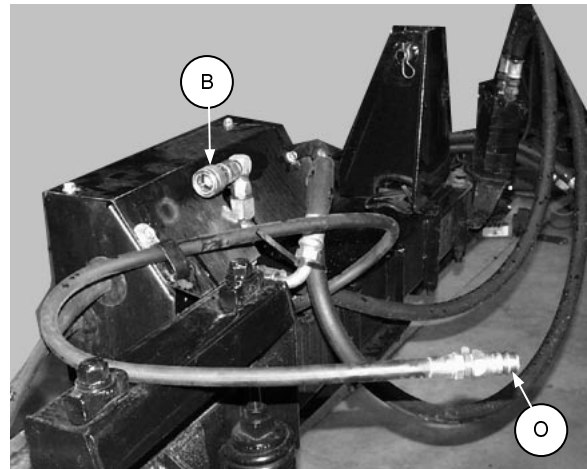

CONNECT DRAPER DRIVE HYDRAULICS

- One connection from header to tractor:
 - 9030 Tractor:** Reel lift to TAN coloured RETRACT coupler (T)
 - TV140 Tractor:** Reel lift to GREEN coloured EXTEND coupler (G)
 - IMPORTANT:** Damage to coupler will occur if attached to any coupler other than GREEN on the TV140 Tractor.

9. Start engine. Activate lower link cylinders to raise adapter until header just starts to lift at cutterbar. Stop engine and remove key.

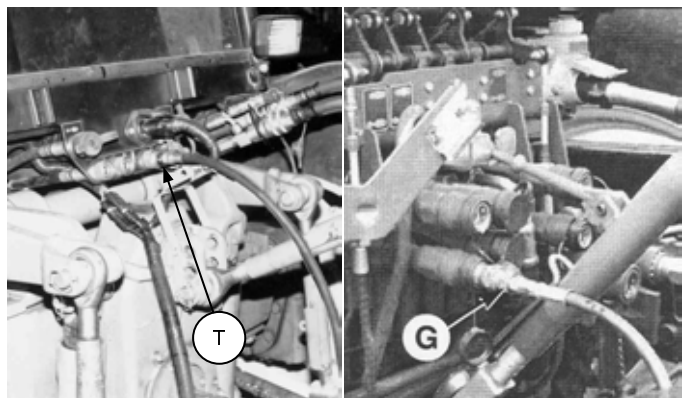

9030 TV140
REEL LIFT HOSE TO TRACTOR



DANGER: Stay out from under header and adapter when removing or installing pins. Three-point linkage drops at a variable rate when engine is shut off.

ATTACHING & DETACHING

ATTACHING HEADER TO TRACTOR AND ADAPTER (continued)

10. Remove pin from float lock-out position (A) and install through header leg at (B), (engaging U-bracket in lift linkage), both sides. Secure with lynch pin.

NOTE: For 960 Headers with "L" pin, rotate pin to align roll pin with key slot for removal and installation. Roll pin locks inside to secure the position.

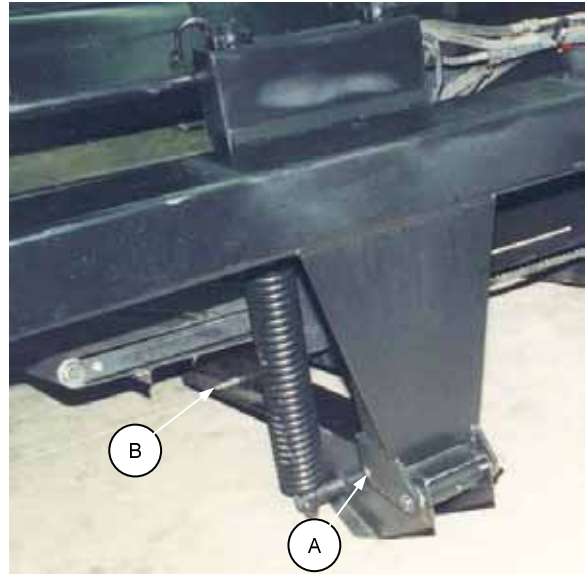

LOCK ADAPTER TO HEADER LEG

11. Start engine. Activate lower link cylinders to raise header fully. Stop engine and remove key.
12. For headers with gauge wheels, remove pins at gauge wheels and place in field position (F). (For headers with gauge wheel/transport option, gauge wheel support is not exactly as illustrated. See decal at support.)

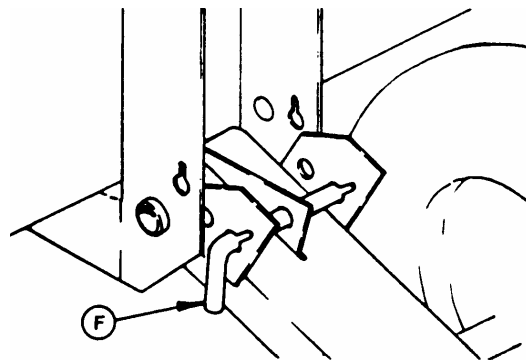

GAUGE WHEELS - FIELD POSITION

13. For headers without gauge wheels, raise header stand to storage position (G).
14. Lower header to cutting height and check that header is level end-to-end. Adjust if required. See "Header Levelling" in Operation section.
15. Lower header and adapter to ground.

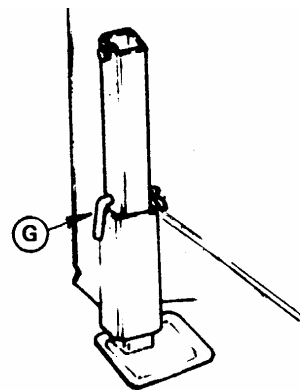

HEADER STAND - STORAGE POSITION

ATTACHING & DETACHING

DETACHING HEADER FROM TRACTOR AND ADAPTER

Using this procedure, adapter will remain attached to the tractor. This would be appropriate when header is to be used on a combine. Instructions for detaching both header and adapter from tractor are given on the next page.

1. Choose a level area. Lower the reel and raise the adapter until header just starts to lift at cutterbar. Stop engine and remove key.



DANGER: Stay out from under header and adapter when removing or installing pins. Three-point linkage drops at a variable rate when engine is shut off.

2. Remove pin from header leg at (B) and install in float lockout position (A), both sides. **NOTE:** Pin goes on top of lift linkage lower member, not through hole (C). This leaves the lift linkage in a position to pick up the header when reattaching. Hole (C) is used only when a header with the optional self-contained transport package is being converted to transport.
3. Start engine. Activate lower link cylinders to raise header fully. Stop engine and remove key.
4. For headers with gauge wheels, remove pins at gauge wheels and place in stand position (D).

For headers without gauge wheels, lower header stand into position (E).

5. Be sure area is clear of bystanders, then start engine. Retract 3-point hitch cylinders to lower header and adapter to the ground. Stop engine and remove key. Block header gauge wheels, if applicable.



DANGER: Wait for all movement to stop. A rotating driveline can cause entanglement resulting in serious personal injury or death.

6. Disconnect motor from header drive shaft and install in storage position on adapter frame.

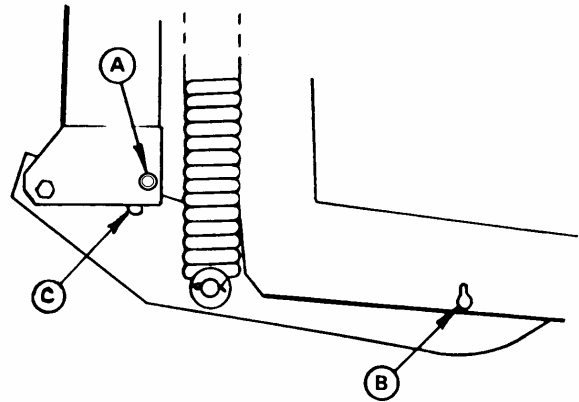

LOCK OUT HEADER FLOAT

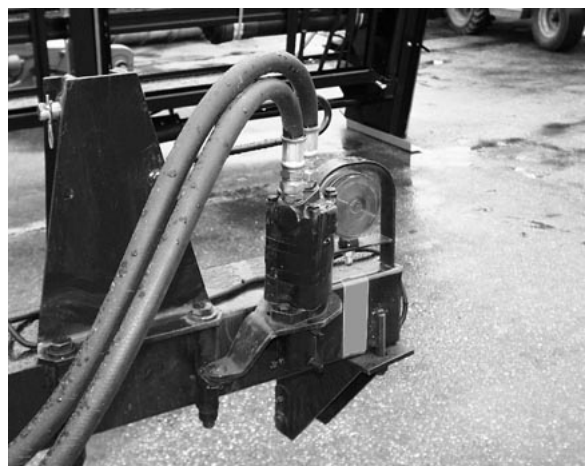
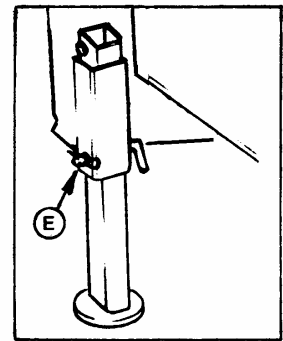
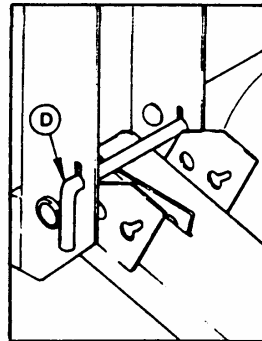

DISCONNECT AND STORE MOTOR

ATTACHING & DETACHING

DETACHING HEADER FROM TRACTOR AND ADAPTER (continued)

7. Disconnect five hydraulic lines:
 - reel drive pressure, reel return (yellow), draper drive pressure (orange) and draper return (blue) at adapter-to-header quick couplers.
 - reel lift at tan coloured RETRACT coupler on 9030 tractor or green coloured EXTEND coupler on TV140 Tractor.

IMPORTANT: Couple or cap all lines to prevent hydraulic system contamination. Be sure header stored hoses and combine stored hoses are not entangled.

8. Disconnect electrical wiring harness near hydraulic motor.
9. Detach center link (H) at header.
10. Slowly back away from header.

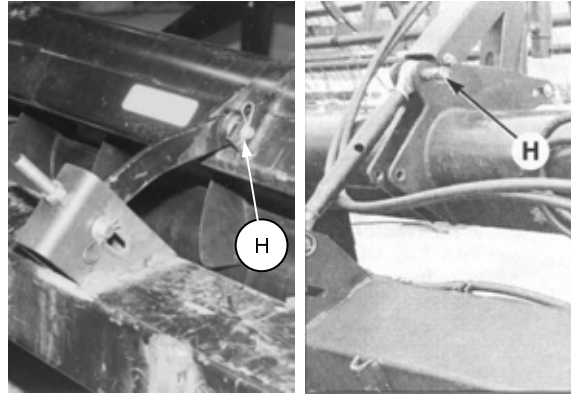

960 HEADER 962/972 HEADERS
DETACH CENTER LINK

DETACHING HEADER AND ADAPTER FROM TRACTOR

Using this procedure, adapter will remain attached to the header. This would be appropriate when tractor is required for other use. Instructions for detaching header only from adapter and tractor are given on previous page.

1. Choose a level area. Lower the reel and lower header and adapter to the ground. Stop engine and remove key.
2. Disconnect three hydraulic lines at tractor quick couplers:
 - Two large couplers (A) at tractor left side.
 - One (reel lift) at TAN-RETRACT coupler (B) for 9030 tractor or GREEN-EXTEND coupler for TV140 Tractor.Couple or cap all lines to prevent hydraulic system contamination.
3. Detach top link (C) at adapter and place in storage support (D).
4. Manually retract latches on 3-point hitch lower links.
5. Detach electrical plug from receptacle (E). Detach header control harness plug at (F).

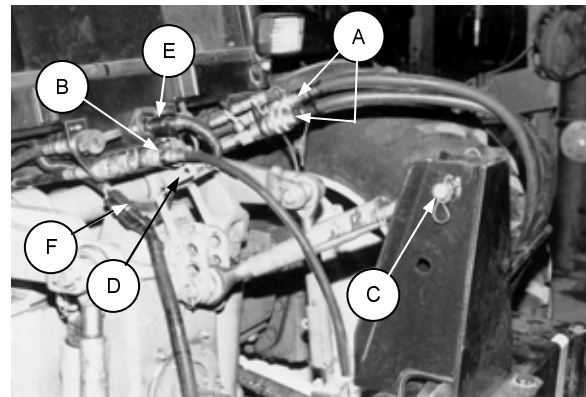

DISCONNECT HYDRAULICS, ELECTRICAL
AND 3-POINT LINKS (9030 SHOWN)



CAUTION: Be sure area is clear of bystanders, then start engine. Fully retract 3-point hitch cylinders and slowly back away from header.

ATTACHING & DETACHING

ATTACHING HEADER AND ADAPTER TO TRACTOR

1. If applicable, block both gauge wheels front and rear (B).

NOTE: Choose an area that is as level as possible.



CAUTION: Be sure area is clear of bystanders before starting engine.

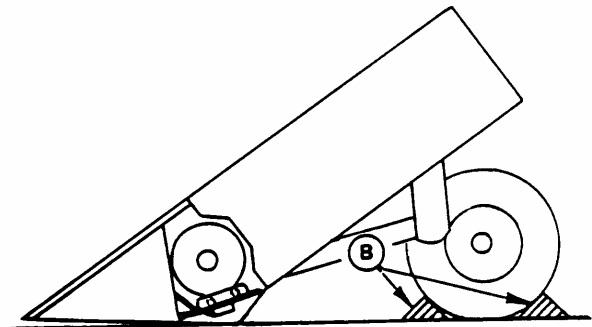

BLOCK GAUGE WHEELS

2. **9030 Tractor:** With the 3-point hitch lower links fully lowered and the top link raised, drive tractor slowly towards the adapter until the lower link claw couplers are below the adapter lower mounts. The large claw openings make exact alignment unnecessary. **NOTE:** For 30' and 36' Headers with Pick-Up Reel where tractor lift rod links have been repositioned to new hole in lower links (see page 6), extend lift rod links to allow linkage to lower further.

Raise the lower links using the hydraulic lift switch until claw couplers engage the ball bushings. An audible click will be heard as the self-locking latches engage. Stop engine and remove key.

3. **TV140 Tractor:** With 3-point hitch lower links fully lowered and the top link raised to storage position, drive the tractor slowly towards the adapter until tractor lower ball joints are just behind the adapter lower mount pins. See Tractor operator's Manual for hook-up procedure.

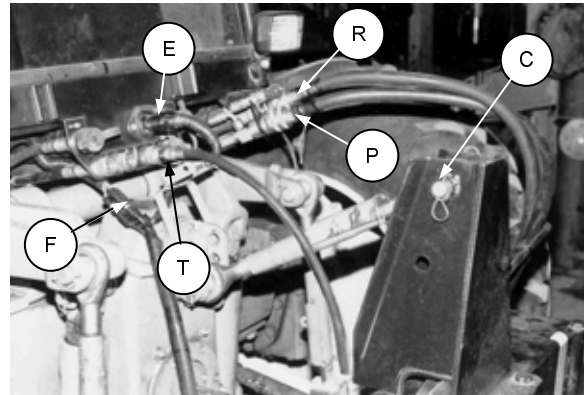

HYDRAULIC & ELECTRICAL CONNECTIONS
(9030 SHOWN)

4. Attach top link to adapter at (C).
5. Attach two 3/4" quick couplers (R) and (P). **IMPORTANT:** Coupler (R) comes from the tee fitting on top of the adapter, and must be attached to the RETURN coupler on the tractor. FAILURE TO PROPERLY CONNECT THIS COUPLER MAY DAMAGE SICKLE DRIVE MOTOR. These mating couplers should both have a black plastic tie fastened to them to ease identification. See "Attaching Adapter to Tractor", page 16, step 4.
6. Attach header reel lift hose coupler to TAN coloured RETRACT coupler (T) on 9030 tractor or GREEN coloured EXTEND coupler on TV140 tractor.
7. Attach 7 terminal plug from header lights wiring harness into tractor at (E). **NOTE:** Be sure that harness is routed behind top link storage support to prevent pinching harness when header is raised.
8. Attach header control harness plug (F) into harness from control panel installed in cab.
9. Raise header to cutting height and check that header is level end-to-end. Adjust if required. See "Header Levelling" in Operation section.
10. Lower header and adapter to ground.

OPERATION

HEADER CONTROLS

Header Drive - Oil flow to hydraulic motor on adapter is controlled with "Detent" (blue) hydraulic lever in cab and the header engage switch on the panel supplied with the adapter. See Tractor Operator's Manual for operation of blue hydraulic lever.

To engage sickle, reel and draper drives:

1. Push lever away from operator until it locks in the detent position.
2. Use switch (A) as follows: Lift the guard to expose toggle switch. Push toggle switch toward guard to engage all header mechanical and hydraulic drives. Push guard down to disengage drives.

Pull lever back to neutral position when header is being transported and when header is removed. Lever functions may also be controlled with the foot pedal immediately right of the left side control panel. Press the toe end of pedal to engage drives, press heel end to disengage.

Reel Speed - Press plus (+) side of switch (B) to increase reel speed and minus (-) side to decrease. Speed range is 10 to 60 RPM.

Draper Speed - Press plus (+) side of switch (C) to increase draper speed and minus (-) side to decrease. Speed range is 0 to 800 roller RPM, or 0 to 470 ft./minute (145 m/min.). A mid-range setting is suggested.

NOTE: If sufficient reel or draper speed cannot be achieved, a possible cause is low relief pressure. See "Hydraulics" in Maintenance/ Service section.

Deck Shift (Hydraulic Shift Headers) - Move switch paddle (D) to the left to shift decks to the left and reverse draper travel. Move paddle to the right to shift decks to the right and reverse draper travel. For center delivery, move paddle to center position.

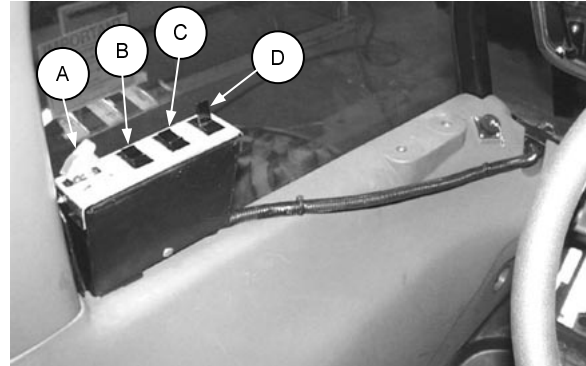

HEADER CONTROL PANEL

Reel Height - Controlled with TAN hydraulic lever on 9030 Tractors and GREEN hydraulic lever on TV140 Tractor. Push lever away from operator to raise reel, pull towards operator to lower. Also may be controlled with foot pedals. Press the toe end of the pedal to raise reel, press heel end to lower.

Header/Adapter Height – See Tractor Operator's Manual for location of these controls:

MANUAL MODE · Set the SELECT switch for 3-point hitch operation to MANUAL mode.

· Control height with 3-point hitch switch on Forward-Neutral-Reverse lever. Press top of switch to raise and bottom to lower. Release switch when desired position is reached.

AUTO MODE

· Set the SELECT switch to AUTO mode.

· Set cab-end ROCKSHAFT POSITION control to desired cutting height.

· Control height with 3-point hitch switch on Forward-Neutral-Reverse lever. Press top of switch to raise header to maximum height. Press bottom of switch to lower header to pre-set cut height.

NOTE: See Tractor Operator's Manual for information regarding variable lowering rate.

When raising the unit, adapter will raise first, then the header. When lowering, the sequence is reversed.



DANGER: Stay out from under header and adapter. Three-point hitch drops at a variable rate when engine is shut off.

OPERATION

HEADER FLOTATION

IMPORTANT:

To avoid:

- frequent breakage of sickle components
- scooping soil
- soil build-up at cutterbar in wet conditions,

set header float as light as possible without causing excessive bouncing.

Under normal conditions, adjust float spring tension so **50 to 70 lbs. force (220 to 300 N)** is required to lift cutterbar off ground at each end.

To adjust header float on 801 adapter:

1. Lower header and adapter to ground.
2. Back jam nut (A) away from spring (two at each adapter leg).
3. Turn bolts (E) clock-wise to increase float (which makes header lighter at cutting height).

Turn bolts counter-clockwise to decrease float (header heavier at cutting height).

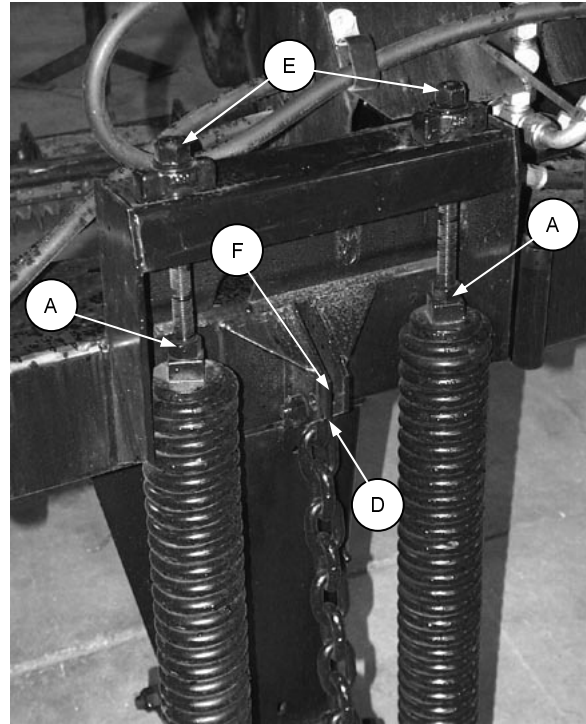

FLOAT ADJUSTMENT – 801 ADAPTER

NOTE: Both springs on one side should be adjusted equally (same exposed bolt length). Due to weight differences side-to-side, adjustments may differ from one leg to the other.

4. Raise adapter until header just starts to lift at cutterbar and check float at both ends. Force required to lift cutterbar should be approximately the same at both ends.

HEADER LEVELLING

To adjust header end-to-end level:

1. Lower header and adapter to ground. Stop engine and remove key.
2. Adjust length of 3-point hitch top link (C) to level header. Turn the sleeve on top link to change length:
 - Shortening link (C) will raise the right end of the header.
 - Lengthening link (C) will lower the right end of the header.
3. If further adjustment is required than can be obtained with link, lower header until chains (shown in photo above) are loose, then move one chain (D) to alternate mounting hole (F) as required to level header. (Remove chain link for further adjustment.)

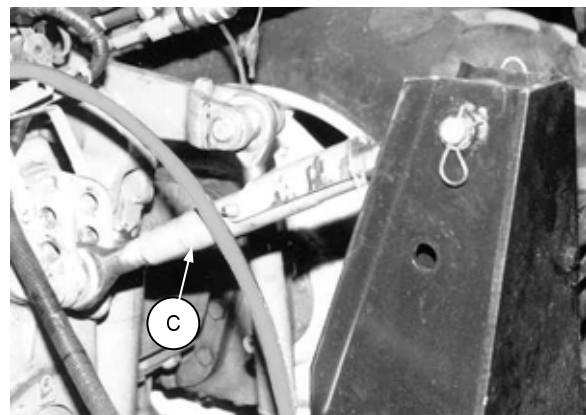

HEADER LEVELLING (9030 SHOWN)

OPERATION

HEADER ANGLE

Header angle is adjustable by changing the length of the center link between header and adapter. On 960 Headers only, further adjustment can be obtained by repositioning lift pads on adapter linkage.

Total header angle adjustment range is 9° to 13° below horizontal, measured at guard tip.

IMPORTANT: A flatter header angle is recommended for normal conditions. A flatter angle reduces sickle section breakage and reduces soil build-up at the cutterbar in wet conditions.

Use a steeper angle to cut very close to the ground, or for better lifting action in down crops.

To adjust header angle:

960 Header:

1. Adjust linkage length with nuts (A). Shortening the link (pulling bar (C) back), will give a flatter angle. Lengthening the link (pushing bar (C) forward) provides a steeper angle.
2. **On 960 Headers only:** If a steeper header angle is required than can be achieved by adjusting center link:

Remove the header and move header lift pads on adapter back by moving mount hardware to holes (G).

IMPORTANT: To avoid possible header or adapter damage, do not reposition header lift pads with 962 or 972 Headers.

962 & 972 Headers:

1. Lower cutterbar to ground.
2. Back off the locking collar (A) on top link turnbuckle.
3. Using a punch in hole in turnbuckle (B), turn to adjust header angle.

Longer top link = steeper header angle

4. At desired adjustment, tighten locking collar (A) securely against turnbuckle to fix the position.
5. Reset float after adjustment.

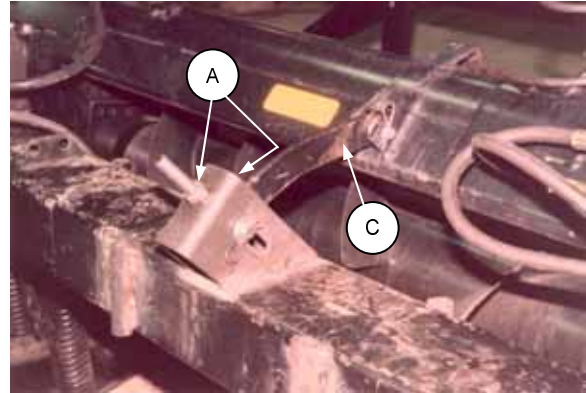

HEADER ANGLE ADJUSTMENT – 960

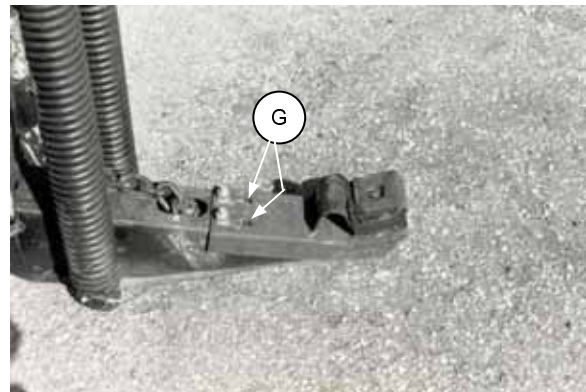

MOVE LINKAGE PADS BACK FOR STEEPER ANGLES – 960 ONLY

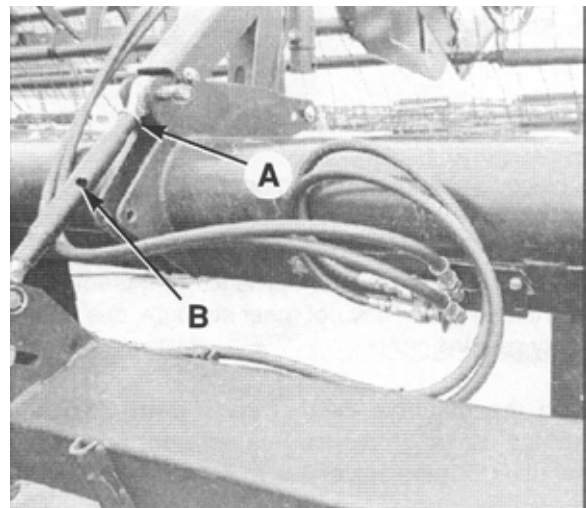

HEADER ANGLE ADJUSTMENT – 962/972

MAINTENANCE/SERVICE

SERVICE PROCEDURES



CAUTION: To avoid personal injury, before servicing machine or opening drive covers:

1. Fully lower header and reel. If it is necessary to service reel in the raised position, first engage reel props.
2. Disengage header drive.
3. Stop engine and remove key.
4. Engage park brake.
5. Wait for all moving parts to stop.

Park on level surface when possible. Block wheels securely. Follow all recommendations in your Tractor Operator's Manual.

Wear close-fitting clothing and cover long hair. Never wear dangling items such as scarves or bracelets.

Wear protective shoes with slip resistant soles, a hard hat, protective glasses or goggles and heavy gloves.

Be prepared if an accident should occur. Know where the first aid kit and fire extinguisher are located and how to use them.

Keep the service area clean and dry. Wet or oily floors are slippery. Wet spots can be dangerous when working with electrical equipment. Be sure all electrical outlets and tools are properly grounded.

Use adequate light for the job at hand.

Replace all shields removed or opened for service.

Use only service and repair parts made or approved by the equipment manufacturer. Substituted parts may not meet strength, design or safety requirements.

Keep the machine clean. Never use gasoline, naphtha or any volatile material for cleaning purposes. These materials may be toxic and/or flammable.

MAINTENANCE/SERVICE

GREASING THE ADAPTER

Use an SAE Multi-Purpose High Temperature Grease with Extreme Pressure (EP) Performance and containing at least 1.5% molybdenum disulphide. Also acceptable is an SAE Multi-Purpose Lithium Base Grease.

The following greasing points are marked on the adapter by decals showing a grease gun (A), and grease interval (B) in hours of operation. Use the hour meter in the tractor cab and the "Maintenance Checklist" provided in the Header Operator's Manual to keep track of scheduled maintenance.

Procedure:

1. Wipe grease fitting with a clean cloth before greasing, to avoid injecting dirt and grit.
2. Inject grease through fitting with grease gun until grease overflows fitting.
3. Leave excess grease on fitting to keep out dirt.
4. Replace any loose or broken fittings immediately.
5. If fitting will not take grease, remove and clean thoroughly. Also clean lubricant passageway. Replace fitting if necessary.

50 Hours

1. Float Arm Pivots (A) - two fittings

500 Hours or Annually

1. Wheel Hub Bearings (B) – one fitting

NOTE: Add these grease points to the Maintenance Checklist in the Header Operator's Manual.

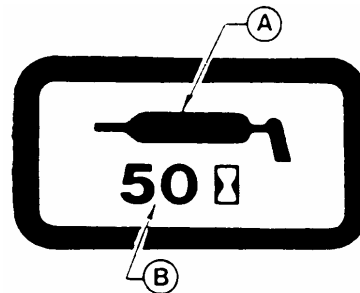

SAMPLE GREASE DECAL

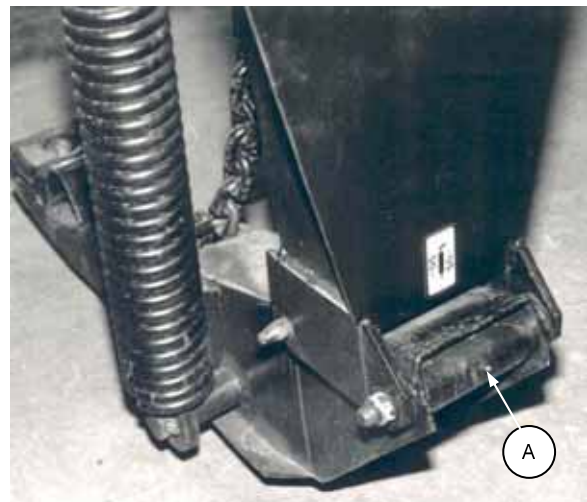

FLOAT ARM PIVOTS



WHEEL HUB BEARINGS

MAINTENANCE/SERVICE

HYDRAULIC SYSTEM

Hydraulic Hoses - Check hydraulic hoses daily for signs of leaks.



WARNING: Avoid high-pressure fluids. Escaping fluid can penetrate the skin causing serious injury. Relieve pressure before disconnecting hydraulic lines. Tighten all connections before applying pressure. Keep hands and body away from pin-holes and nozzles which eject fluids under high pressure. Use a piece of cardboard or paper to search for leaks. **IF ANY** fluid is injected into the skin, it must be surgically removed within a few hours by a doctor familiar with this type of injury or gangrene may result.

IMPORTANT:

- Ensure all hydraulic couplings are properly mated and fully engaged before operating header. In particular, be sure return flow from adapter is connected to tractor return coupler. Failure to connect hydraulics correctly may damage sickle drive motor. See "Attaching Adapter to Tractor", page 9, step 4.
- To avoid damage to sickle drive motor, do not exceed 20 gallons/minute flow or 3000 psi relief pressure. See Tractor Operator's Manual.
- Keep hydraulic coupler tips and connectors clean. Dust, dirt, water and foreign material are the major causes of hydraulic system damage.
- To prevent improper mixing of oils: If header is to be switched back and forth from combine to Bi-Directional tractor, change oil in tractor hydraulic system and in combine adapter hydraulic reservoir to match combine hydraulic system.



AVOID HIGH-PRESSURE FLUIDS



CHECK PROPERLY FOR LEAKS

MAINTENANCE/SERVICE

HYDRAULIC SYSTEM (continued)

FLOW CONTROL BLOCK

Flow control block (A) provides hydraulic power to the reel and draper drives with flow variable from 5 to 8 gallons per minute (gpm) to each circuit.

Header Drive Relief Pressure

Overload protection for the reel and draper drives is provided by the relief valve on the tractor. Should stalling problems develop with one of the header hydraulic circuits, check and adjust relief pressure according to instruction in the Tractor Operator's Manual.

Pressure should be 2700 to 3000 psi (18.6 to 20.7 MPa).

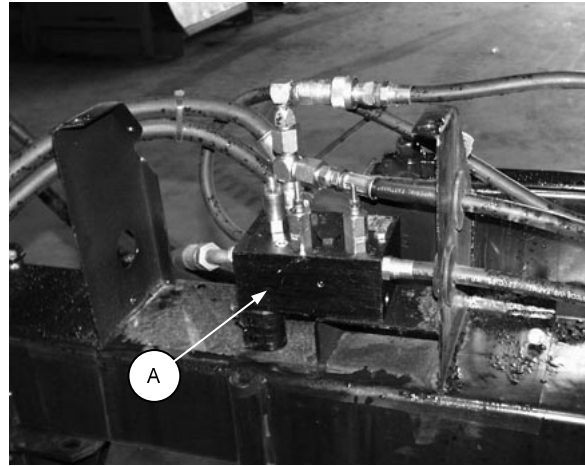

FLOW CONTROL BLOCK

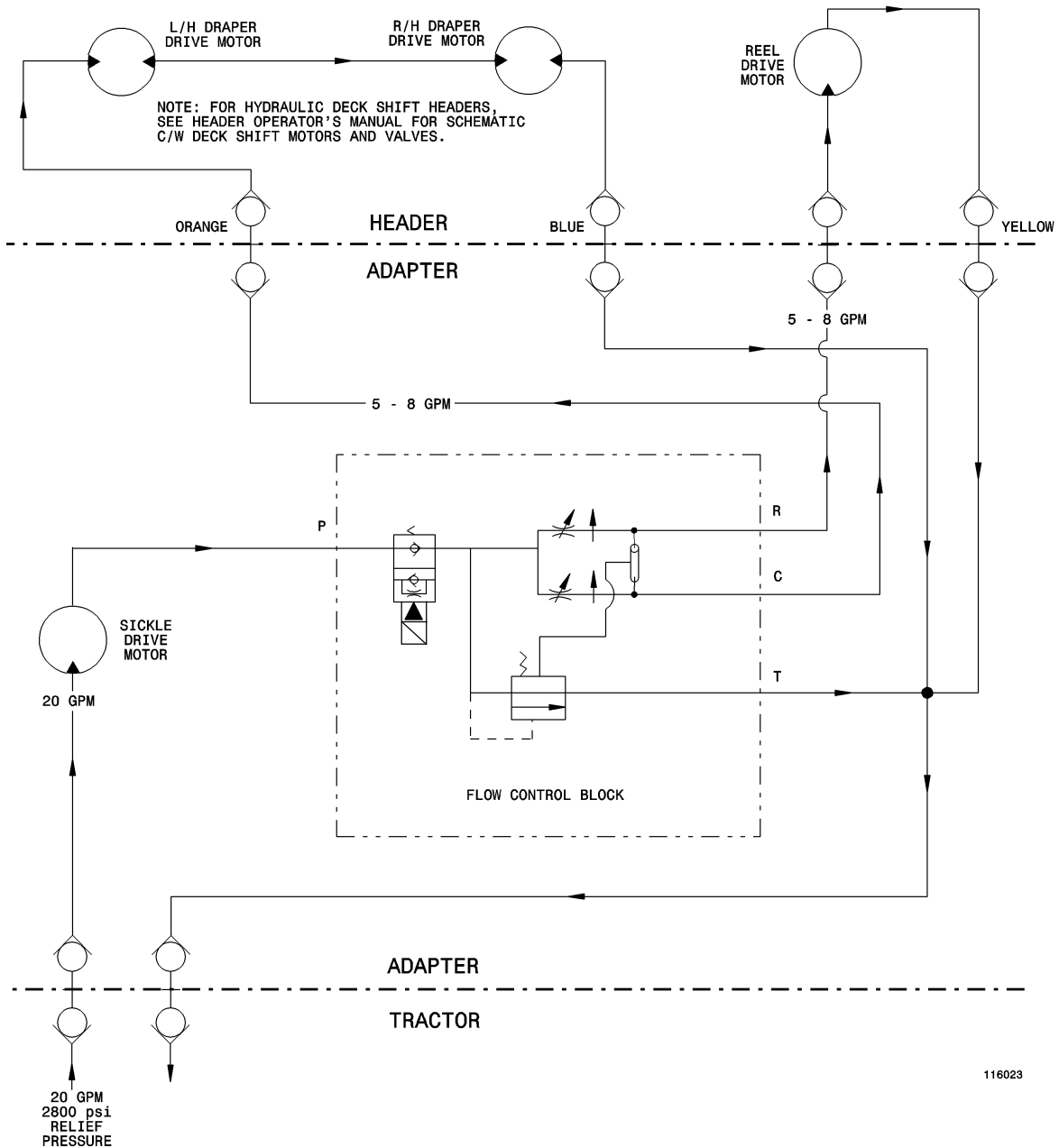

116023

MAINTENANCE/SERVICE

ELECTRICAL SCHEMATIC

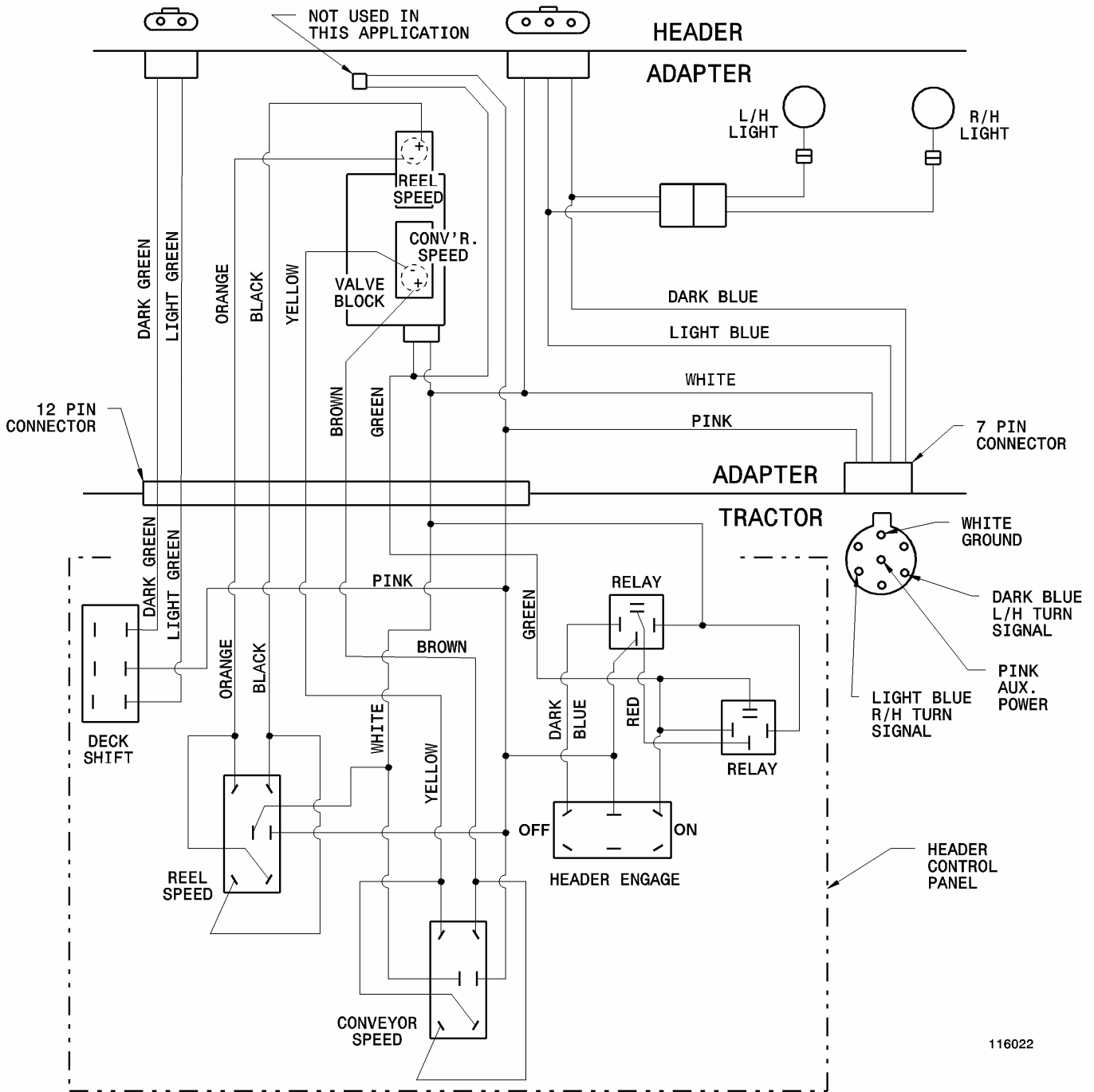

116022

MAINTENANCE/SERVICE

WHEEL & TIRE MAINTENANCE

Wheel Bolts

Check and tighten wheel bolts after the first 10 hours of operation and every 100 hours thereafter.

Whenever a wheel is removed and re-installed, check torque after one hour of operation.

Maintain torque at: 80 to 90 ft.lbs. (110 to 120 N·m)

Follow the proper bolt tightening sequence shown.

NOTE: When installing wheel, be sure valve stem (C) points away from wheel support.

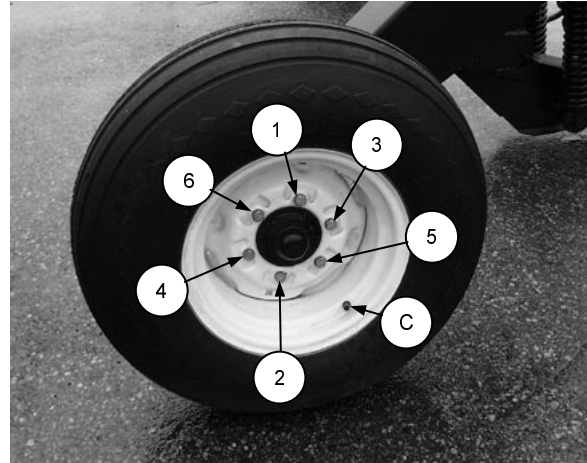

WHEEL BOLTS

Tire Inflation

Check tire pressure daily. Maintain 10 psi (70 kPa) pressure.



WARNING: Service tires safely. A tire can explode during inflation and cause serious injury or death. Never increase air pressure beyond 35 psi (241 kPa) to seat the bead on the rim. Replace the tire if it has a defect. Replace a wheel rim which has cracks, wear or severe rust. Never weld a wheel rim. Make sure all the air is removed from a tire before removing the tire from a rim. Never use force on an inflated or partially inflated tire. Make sure the tire is correctly seated before inflating to operating pressure.

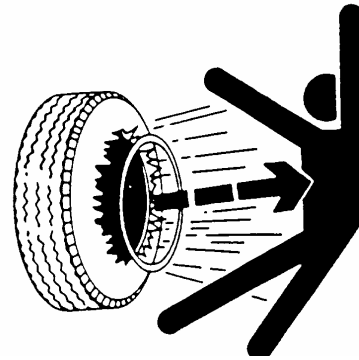

SERVICE TIRES SAFELY

Do not remove, install or make repairs to a tire on a rim unless you have the proper equipment and experience to perform the job. Take the tire and rim to a qualified tire repair shop. If the tire is not in correct position on the rim, or is too full of air, the tire bead can loosen on one side, causing air to leak at high speed and with great force. An air leak of this nature can thrust the tire in any direction, endangering anyone in the area.

(A) - Use a safety cage if available.

(B) - Do not stand over tire. Use a clip-on chuck and extension hose.

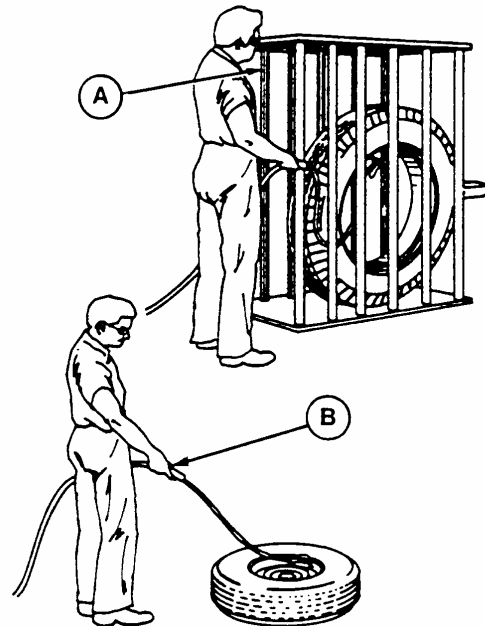

TRANSPORT



CAUTION: For transporting header while it remains attached to tractor in field position, pin must remain in position (L), locking header to adapter.

IMPORTANT: The following applies to headers with the gauge wheel/transport option only, and only when the header is being converted for end transport.

Converting from field position to transport:

Refer to instructions for converting from field position to transport on page 31 of your Header Operator's Manual.

Before proceeding with step 1, lower adapter to ground and lock the adapter float arm to lower leg by installing pin at (K), both sides.

Converting from transport to field position:

Follow instructions on pages 34 and 35 of your Header Operator's Manual, then lower header and adapter to ground and remove pin from position (K) and install through header leg at (L), (engaging U-bracket in lift linkage), both sides.

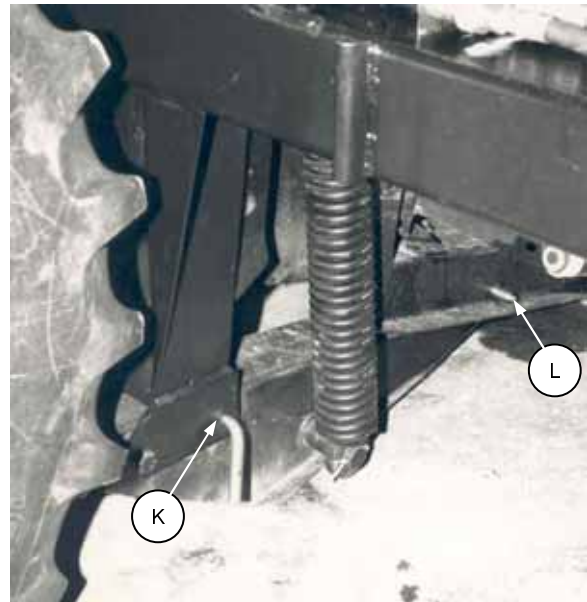

**HEADERS WITH TRANSPORT OPTION ONLY:
LOCK FLOAT ARM TO LEG FOR TRANSPORT**

TROUBLE SHOOTING

<u>SYMPTOM</u>	<u>PROBLEM</u>	<u>SOLUTION</u>	<u>REF.</u>	
Header will not lift.	Improper relief setting on tractor.	Adjust tractor relief setting.	*	
	3-point hitch lift links too long.	Shorten lift links to minimum length.	6	
	36' Header with Pick-Up Reel too heavy.	Move 3-point hitch center link to upper hole at tractor.	6	
Reel does not operate smoothly.	Improper hydraulic flow.	Ensure that 3/4" hoses to reel/draper flow valve are attached to BLUE hydraulic circuit with 20 GPM flow and open return to tank on tractor.	16 6/8	
		Side drapers stall.	Ensure that 3/4" hoses to reel/draper flow valve are attached to BLUE hydraulic circuit with 20 GPM flow and open return to tank on tractor.	16 6/8
Header improperly adjusted.	Header improperly adjusted.	Adjust header as recommended.	*	
		Improper relief setting on tractor.	Check tractor relief setting.	*
		Header or reel does not lift fast enough.	Raising header and/or reel while turning tractor.	To reduce lift time, do not lift header or reel while turning tractor.
Header or reel does not lift fast enough.	Flow to header drives set too high.	Set flow through BLUE hydraulic circuit to 20 GPM.	6/8	
		Re-direct some flow from header drive to lift circuits: <ul style="list-style-type: none"> • Set reel and draper to desired speeds. • Decrease flow in BLUE circuit until reel and/or drapers start to slow. 	-	
	Tractor is not supplying enough oil.	Check tractor hydraulics	*	

* - See Tractor or Header Operator's Manual

TROUBLE SHOOTING

<u>SYMPTOM</u>	<u>PROBLEM</u>	<u>SOLUTION</u>	<u>REF.</u>
Reel and/or drapers run too slow.	Raising header and/or reel while turning tractor.	To maintain reel and draper speeds, do not lift header or reel while turning tractor.	-
	Flow to lift circuits set too high.	Reduce oil flow to TAN and/or GREEN circuits.	*
	Flow to header drives set too low.	Set flow through BLUE hydraulic circuit to 20 GPM.	6/8
	Tractor is not supplying enough oil.	Check tractor hydraulics	*
Sickle drive motor vibrates.	Improper belt length on 960 Header	Replace belt.	20
	Holes not added to reposition drive shaft for belt alignment on 21' & 25' 960 Headers	Add holes to bearing mounting plate and frame bracket.	18
	Improper hydraulic flow.	Reduce or increase oil flow in BLUE hydraulic circuit until vibration stops. Flow should be 20 GPM (570 RPM at sickle driver pulley).	*
Improper feeding.	Crop catches on float springs.	Install back sheet extensions.	**
	Crop will not go under tractor.	Offset tractor from delivery opening.	15
		Install cross auger assembly from combine adapter.	**
		Install windrow deflector under tractor.	**
Tractor will not push adapter frame.	Adapter wheel packed with mud.	Move tractor to center.	15
		Lock out float on 3-point hitch.	*
		Remove wheel and spindle on adapter.	---
Cutterbar does not float or pushes dirt.	Float too heavy.	Adjust to lighter float.	28
	Float lockout not disengaged.	Raise header and disengage float lockout.	36

* - See Tractor or Header Operator's Manual

** - See MacDon Dealer

TROUBLE SHOOTING

<u>SYMPTOM</u>	<u>PROBLEM</u>	<u>SOLUTION</u>	<u>REF.</u>
Cutterbar not level.	Center link improper length.	Adjust center link length.	28
	Chains not tight.	Reduce float.	28
	Center link too high at tractor.	Move link down to lowest hole.	6
	Chain lengths not equal.	Move chain to alternate mounting hole.	28
Tires running over crop.	Tractor wheels improperly set.	Remove link from chain.	28
		Adjust wheels. For TV140 Tractor, wheel spacers are required for tread widths over 80" (supplied by New Holland).	*
	Crop fanning out excessively.	Adjust header opening.	*
		Install windrow forming rods (972 Header only).	*

* - See Tractor or Header Operator's Manual

INDEX

<u>A</u>	PAGE
Attaching Adapter to Tractor	16
Attaching Header and Adapter to Tractor	26
Attaching Header to Tractor and Adapter	21

<u>D</u>	
Deck Shift Control	27
Detaching Header and Adapter from Tractor	25
Detaching Header from Tractor and Adapter	24
Draper Speed Control	27

<u>E</u>	
Electrical Schematic	34

<u>G</u>	
Greasing the Adapter	31

<u>H</u>	
Header/Adapter Height Control	27
Header Angle	29
Header Drive Control	27
Header Flotation	28
Header Levelling	28
Hydraulic Flow Control Block	33
Hydraulic Hoses	32
Hydraulic Schematic	33
Hydraulic System Safety	32

<u>P</u>	
Preparing the Adapter	11
Preparing the Header	17
Preparing the Tractor	6

<u>R</u>	
Reel Height Control	27
Reel Speed Control	27
Relief Pressure	33

<u>S</u>	PAGE
Safety	
Alert Symbol	4
Hydraulic System	32
Service Procedures	30
Signal Words	4
Signs	5
Serial Number Location	3
Service Procedures	30

<u>I</u>	
Transport	36
Trouble Shooting	37

<u>W</u>	
Wheel & Tire Maintenance	35