

# MacDon

**Model 960  
Harvest Header**

**ADAPTER  
OPERATOR'S MANUAL  
SUPPLEMENT  
for  
FORD-VERSATILE 9030  
BI-DIRECTIONAL TRACTOR**



**MacDon Industries Ltd.**

680 Moray Street, Winnipeg, Manitoba  
Canada R3J 3S3  
(204) 885-5590, Fax 832-7749  
Telex 07-57849



# INTRODUCTION

This Manual Supplement contains information on the adapter which is required to allow attachment of the MacDon Model 960 Harvest Header to the Ford-Versatile 9030 Bidirectional Tractor.

**NOTE:** This supplement does not provide all the information required to operate the header. It must be used in conjunction with your Harvest Header and Tractor Operator's Manuals.

**CAREFULLY READ ALL MANUALS TO BECOME FAMILIAR WITH RECOMMENDED PROCEDURES BEFORE ATTEMPTING TO UNLOAD, ASSEMBLE OR USE THE MACHINE.**

This manual is divided into sections on: "Safety", "Attaching and Detaching the Header", "Operation" and "Maintenance/Service".

Use the Table of Contents and the Index to guide you to specific areas. Study the Table of Contents to familiarize yourself with how the material is organized.

Keep this manual handy for frequent reference and to pass on to new operators or owners. Call your dealer if you need assistance, information or additional copies of the manual.

**NOTE:** Right hand (R/H), and Left hand (L/H) designations are determined from the operators position, facing the header.



# TABLE OF CONTENTS

|   |       |
|---|-------|
| INTRODUCTION .....                              | 1     |
| SERIAL NUMBER LOCATION .....                    | 3     |
| <b>SAFETY</b>                                   |       |
| Safety Alert Symbol .....                       | 4     |
| Signal Words .....                              | 4     |
| Safety Signs .....                              | 5     |
| <b>ATTACHING &amp; DETACHING</b>                |       |
| Preparing the Tractor .....                     | 6     |
| Preparing the Adapter .....                     | 7,8   |
| Attaching Adapter to Tractor .....              | 9     |
| Preparing the Header .....                      | 10    |
| Attaching Header to Tractor and Adapter .....   | 11-13 |
| Detaching Header from Tractor and Adapter ..... | 14,15 |
| Detaching Header and Adapter from Tractor ..... | 15    |
| Attaching Header and Adapter to Tractor .....   | 16    |
| <b>OPERATION</b>                                |       |
| Header Controls                                 |       |
| Header Drive .....                              | 17    |
| Reel Speed Control .....                        | 17    |
| Draper Speed Control .....                      | 17    |
| Deck Shift (Triple Delivery Headers) .....      | 17    |
| Reel Height Control .....                       | 17    |
| Header/Adapter Height Control .....             | 17    |
| Header Flotation .....                          | 18    |
| Header Levelling .....                          | 18    |
| <b>MAINTENANCE/SERVICE</b>                      |       |
| Service Procedures .....                        | 19    |
| Greasing the Adapter .....                      | 20    |
| Hydraulic System                                |       |
| Hydraulic System Safety .....                   | 21    |
| Hydraulic Hoses .....                           | 21    |
| Draper Drive Flow Control Relief Pressure ..... | 21    |
| Reel Drive Relief Valve Pressure .....          | 22    |
| Hydraulic Schematic .....                       | 22    |
| Wheel & Tire Maintenance .....                  | 23    |
| <b>TRANSPORT</b> .....                          | 23    |
| <b>INDEX</b> .....                              | 24    |

# SERIAL NUMBER LOCATION

Record the serial number in the space provided.

9030 Adapter: \_\_\_\_\_

Plate is located on right side of adapter frame.

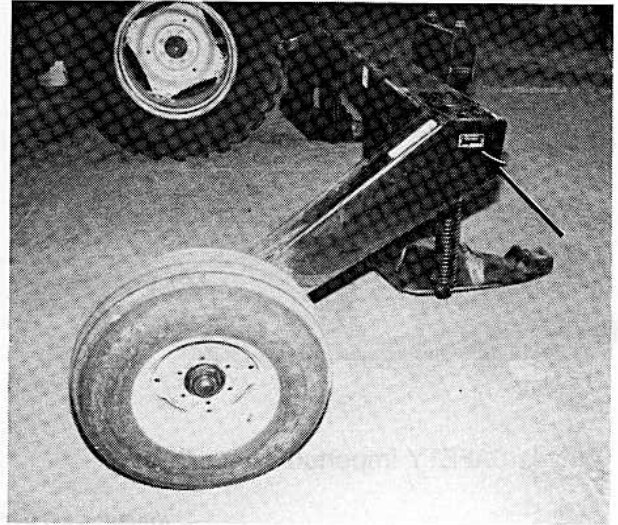

9030 ADAPTER SERIAL PLATE

**NOTE:** When ordering parts and service, be sure to give your dealer the complete and proper serial number.



**SAFETY ALERT SYMBOL**



This safety alert symbol indicates important safety messages in this manual and on safety signs on the machine.

This symbol means: **ATTENTION !  
BECOME ALERT !  
YOUR SAFETY IS INVOLVED !**

Carefully read and follow the safety message accompanying this symbol.

Why is SAFETY important to you?

3 BIG REASONS

- ACCIDENTS DISABLE AND KILL
- ACCIDENTS COST
- ACCIDENTS CAN BE AVOIDED

**SIGNAL WORDS**

Note the use of the signal words DANGER, WARNING, and CAUTION with safety messages. The appropriate signal word for each message has been selected using the following guidelines:



- an immediate and specific hazard or forbidden practice which WILL result in severe personal injury or death if the message is not followed.



- a specific or unsafe practice which COULD result in severe personal injury or death if the message is not followed.



- unsafe practice which could result in personal injury if the message is not followed, or a reminder of good safety practices.

# SAFETY

## SAFETY SIGNS

- The safety signs below appear on the adapter.
- Keep safety signs clean and legible at all times.
- Replace safety signs that are missing or become illegible.
- If original parts on which a safety sign was installed are replaced, be sure the repair part also bears the current safety sign.
- Safety signs are available from your Dealer Parts Department.

### To install safety signs:

1. Be sure the installation area is clean and dry.
2. Decide on the exact location before you remove the decal backing paper.
3. Remove the smaller portion of the split backing paper.
4. Place the sign in position and slowly peel back the remaining paper, smoothing the sign as it is applied.
5. Small air pockets can be smoothed out or pricked with a pin.

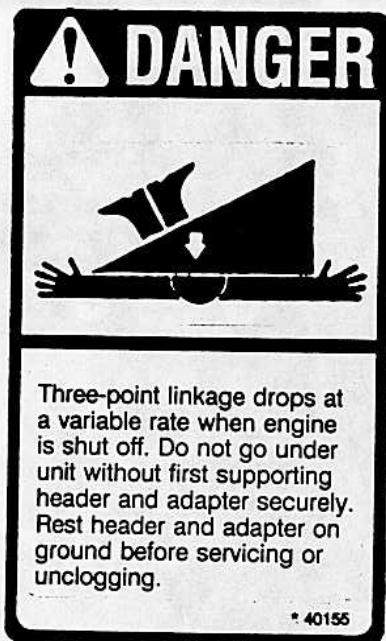

ADAPTER FRAME



TOP LINK ANCHOR



TOP LINK ANCHOR

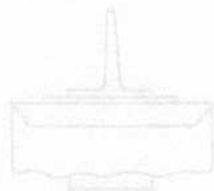

(REAR VIEW)

DARK GREEN  
PINK  
LIGHT GREEN

DECK SHIFT PADDLE SWITCH WIRING  
(Type Delivery Header)

# ATTACHING & DETACHING

## PREPARING THE TRACTOR

1. Check with your dealer to ensure tractor is properly equipped to carry header.

### TRACTOR REQUIREMENTS:

- Two 3/4 inch female hydraulic quick couplers (16 GPM) (ASAE/SAE/ISO approved).
- Cab end 3-point hitch (ASAE S217.10 category II).
- 7 terminal electrical receptacle (SAE J560b) with auxiliary switch in cab.

2. Set the hydraulic oil flow to the header at 16 gallons/minute (GPM). See your Tractor Operator's Manual.

**IMPORTANT:** Damage to the sickle drive motor on the adapter may occur if the flow is greater than 16 GPM.

3. Set the 3-point hitch as follows:
  - Lift rod link in float position (A).
  - Stabilizers locked at (B) to prevent sideways movement of the lower links.
  - Upper link set at lowest hole (C).

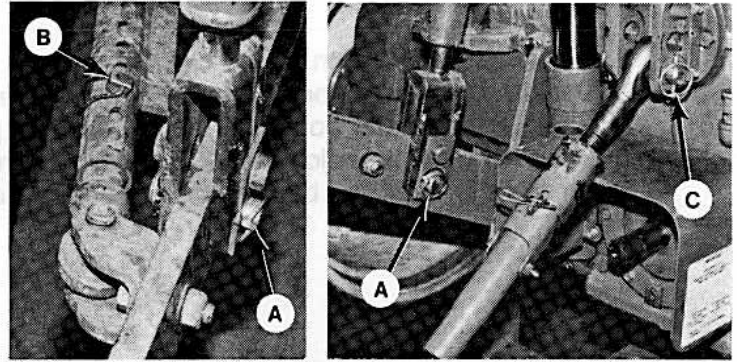

3-POINT HITCH SETTINGS

4. Install the header control panel in cab:
  - Pull the floor mat back. Remove the "knock-out" plug from the 1 3/4" (45 mm) hole (D) in the floorboard. Hole is located 7" (180 mm) forward of floor bend-line, and 13" (330 mm) from the side of the console.
  - Route the two harness plugs down through the hole. Pull the plugs down between the hoses to the GREEN hydraulic couplers.
  - Position controller panel (E) even with the top of console. Align front of panel with edge of Rockshaft Position panel (F). Mark the mounting hole position and drill two 1/8" (3 mm) holes. Secure panel to console with two #10 x 1/2" self-tapping screws.

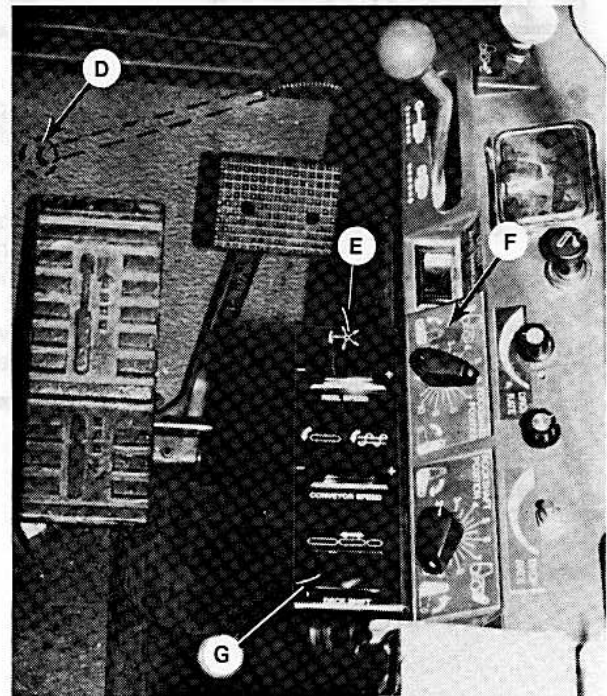

INSTALL HEADER CONTROL PANEL

**NOTE:** For Triple Delivery Header, install deck shift paddle switch (shipped with the header) in control panel as follows:

- Cut decal to expose third switch hole (G) in panel.
- Push switch into hole and attach wires from harness as shown.
- When header is attached, check function of deck shift switch. Moving switch paddle to the left should shift decks to the left. If moving paddle to the left shifts decks to the right and vice-versa, exchange positions of the two green wires at the switch.

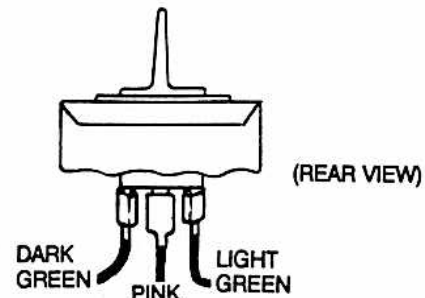

DECK SHIFT PADDLE SWITCH WIRING  
(Triple Delivery Headers)



# ATTACHING & DETACHING

## PREPARING THE ADAPTER

There are three positions on the adapter for the 3-point hitch mounts. See chart below for capabilities and restrictions of each position:

### ABBREVIATIONS:

CD = Center Delivery

ED = Left End Delivery

**NOTE:** Right End delivery is possible at all adapter positions, on all sizes of Triple Delivery Header, with the following limitations:

21' - Move adapter wheel to left side of frame leg.

| Tractor Position | Header Size  |  |   |   |
|------------------|--|--|---|---|
|                  | 21'  | 25'  | 30'   | 36'   |
| 1                | CD - left side of tractor extends past left end of header. Use for cutting around perimeter of crop only.  | CD - wide opening possible.<br>ED - under tractor (light crop only).   | CD - wide opening possible.<br>ED - opening limited to 50 inches (1270 mm).   | CD & ED - wide opening possible.  |
| 2                | CD - tractor wheel stance must be set narrow. Opening limited to 50" (1270 mm).  | CD - tractor wheel stance must be set narrow. Opening limited to 50" (1270 mm).  | CD - tractor wheel stance must be set narrow. Opening limited to 50" (1270 mm).<br>ED - wide opening possible.                                | CD - narrow stance. Opening limited to 50" (1270 mm).<br>ED - wide opening possible.  |
| 3                | CD - under tractor (light crop only). Tractor wheel stance must be set wide. Opening limited to 46" (1170 mm).<br>ED - tractor wheel stance must be set narrow. Wide opening possible. | CD - under tractor (light crop only). Tractor wheel stance must be set wide. Opening limited to 46" (1170 mm).<br>ED - tractor wheel stance must be set narrow for full width opening. | CD - under tractor (light crop only). Tractor wheel stance must be set wide. Opening limited to 46" (1170 mm).<br>ED - wide opening possible. | CD - under tractor (light crop only). Tractor wheel stance must be set wide. Opening limited to 46" (1170 mm).<br>ED - wide opening possible. |

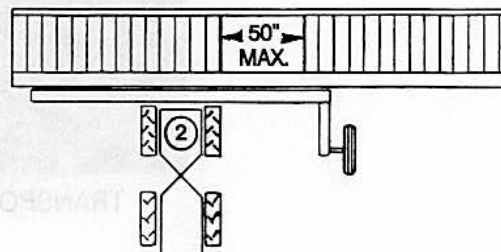
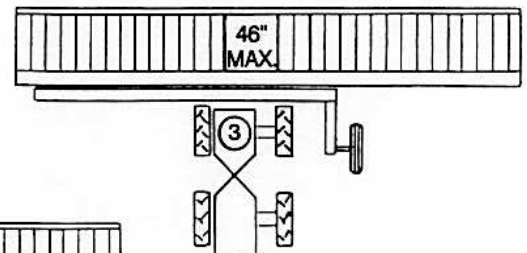
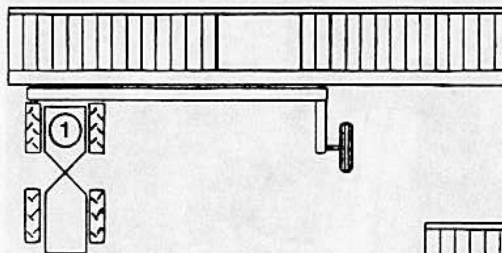

# ATTACHING & DETACHING

## PREPARING THE ADAPTER (continued)

Move the 3-point hitch mounts (E) and (F) to the desired location on the adapter frame.

**NOTE:** When moving mounts (E) and (F) to position (1), remove pin (H) and move ball (G) to position (G-1). Install pin (H) to secure ball in new position.

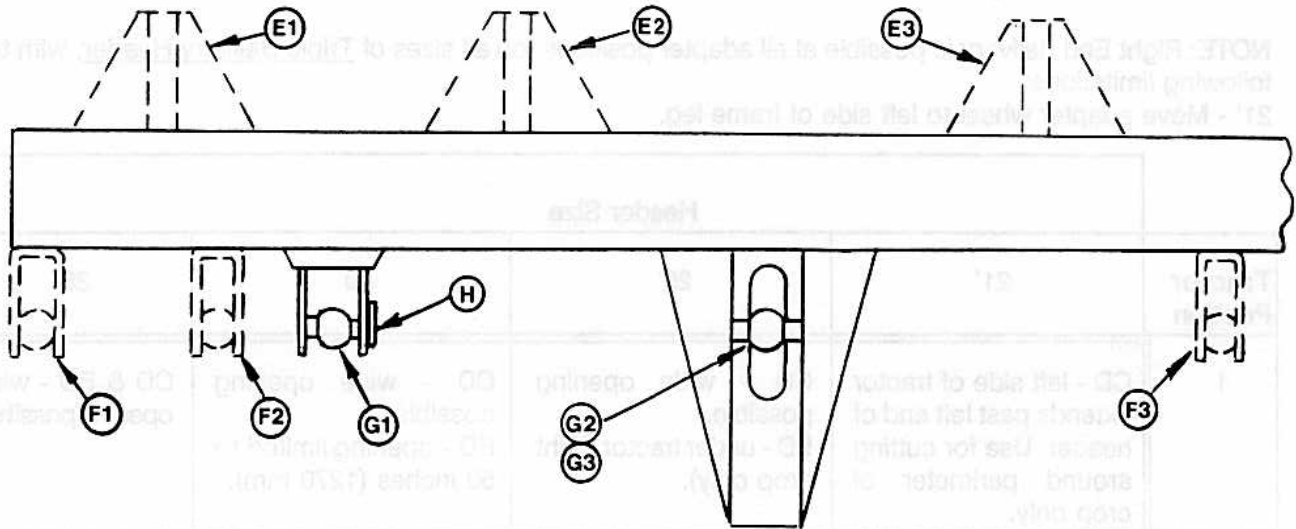

3-POINT HITCH MOUNT POSITIONS

**NOTE:** For headers with gauge wheels, remove left gauge wheel before attempting to attach header to tractor in the following combinations:

30' or 36' Header - Tractor in position 1.

30' Header - Tractor in position 2.

To remove gauge wheel, remove bolt (A) and slide spindle out of support.

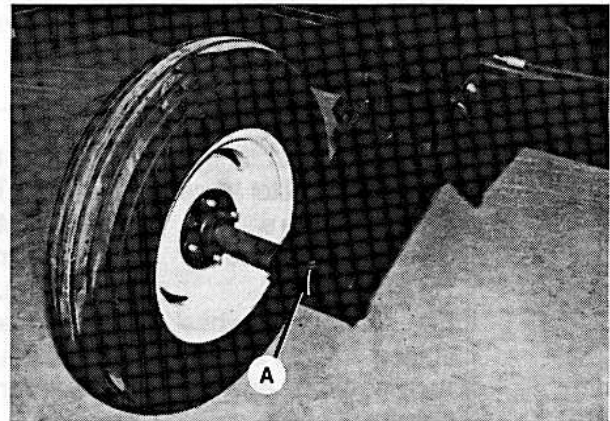

REGULAR GAUGE WHEEL

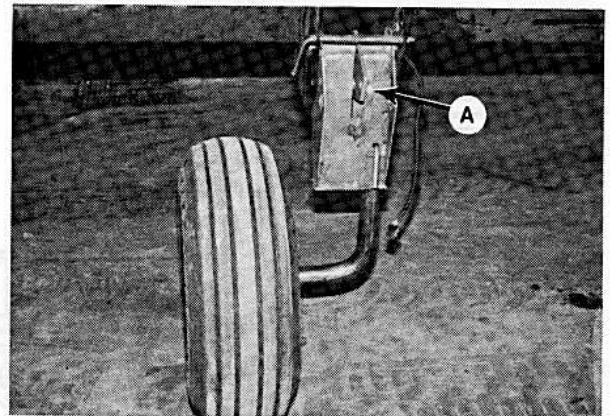

TRANSPORT OPTION GAUGE WHEEL

# ATTACHING & DETACHING

## ATTACHING ADAPTER TO TRACTOR

1. With 3-point hitch lower links fully lowered and the top link raised to storage position, drive the tractor slowly towards the adapter until the lower link claw couplers are below the adapter lower mounts. The large claw openings make exact alignment unnecessary.
2. Raise the lower links using the hydraulic lift switch until claw couplers engage the ball bushings. An audible click will be heard as the self-locking latches engage. Stop engine and remove key.
3. Attach top link to adapter at (C).
4. Identify 3/4 inch PRESSURE and RETURN couplers on tractor: Return coupler is connected to a single larger hose. Pressure coupler is attached to two smaller hoses, one of which is routed to BLUE-EXTEND coupler.

Attach quick coupler (R) to the tractor RETURN coupler.

**IMPORTANT:** Coupler (R) comes from the tee fitting on top of the adapter, and must be attached to the RETURN coupler on the tractor. FAILURE TO PROPERLY CONNECT THIS COUPLER MAY DAMAGE SICKLE DRIVE MOTOR. Coupler (R) has a black plastic tie fastened to it. To ease identification of mating couplers, attach the other black tie (supplied) to the tractor RETURN coupler.

Attach quick coupler (P) to the tractor PRESSURE coupler.

5. Attach 7 terminal plug from header lights wiring harness into tractor at (E).  
**NOTE:** Be sure that harness is routed behind top link storage support to prevent pinching harness when header is raised.
6. Attach header control harness plugs (F) into harness from control panel installed in cab. See "Preparing the Tractor".

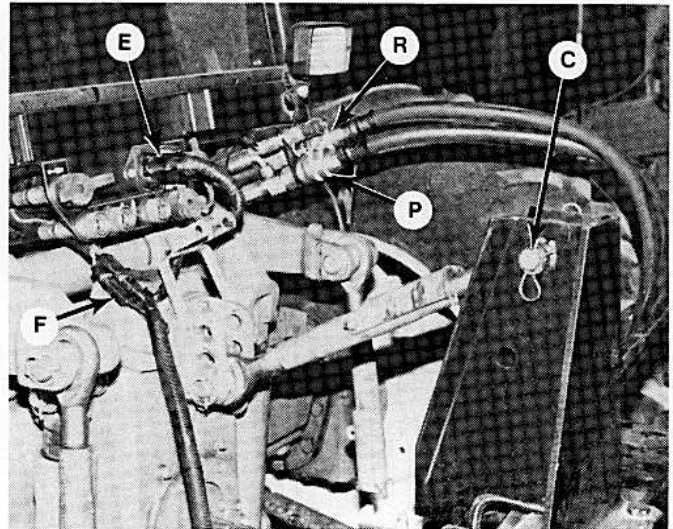

HYDRAULIC & ELECTRICAL CONNECTIONS

# ATTACHING & DETACHING

## PREPARING THE HEADER

1. Attach linkage supports (supplied with adapter package) to lower header legs with 5/8 locknut at (A).
2. Install quick couplers (supplied with adapter package) to header hoses:
  - Reel Drive Pressure - 1/2 NPT male coupler
  - Reel Drive Return - 1/2 NPT female coupler (yellow colour code)
  - Reel Lift - 1/2 NPT male coupler with 1/4 NPT hose extension.

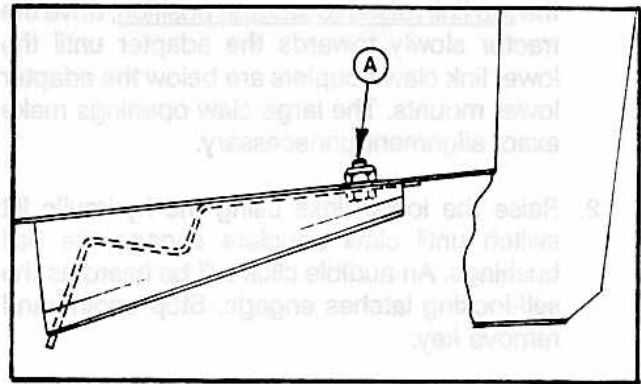

ATTACH LINKAGE SUPPORTS TO HEADER LEGS

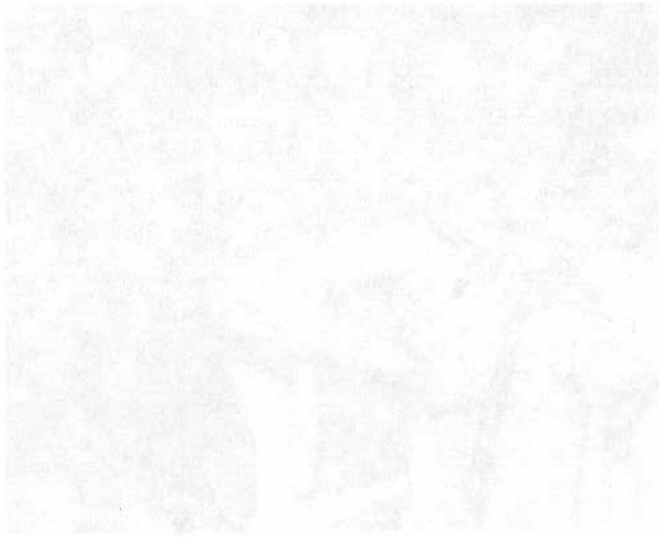

HYDRAULIC & ELECTRICAL CONNECTORS

# ATTACHING & DETACHING

## ATTACHING HEADER TO TRACTOR AND ADAPTER

1. **NOTE:** Choose an area that is as level as possible.

For headers without gauge wheels, be sure header stand is secure in the down position (A).

For headers with gauge wheels, block both wheels front and rear, and be sure gauge wheel pins are in stand position (L), both sides, to support rear of header.

**NOTE:** If L/H gauge wheel has been removed for left side tractor positioning, use left gauge wheel support in "transport" position as a stand.

**IMPORTANT:** Be sure linkage supports are attached to header lower legs. See "Preparing the Header", page 9.

2.  **CAUTION:** Be sure area is clear of bystanders, then start engine.

Fully retract 3-point hitch cylinders.

3. Slowly drive tractor forward so that adapter lift linkage enters header legs. Continue to drive slowly forward until linkage contacts support plate in the lower header leg, and header nudges forward. Stop engine and remove key.

4. Install center link (B) from adapter to header.

5. Check that bottom of linkage (D) is properly engaged in header leg, contacting support plate (E).



HEADER STAND

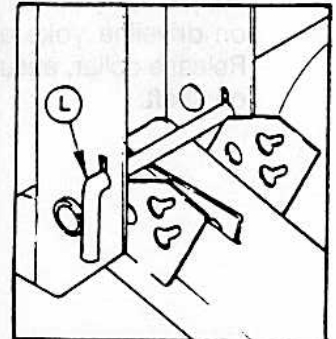

GAUGE WHEELS

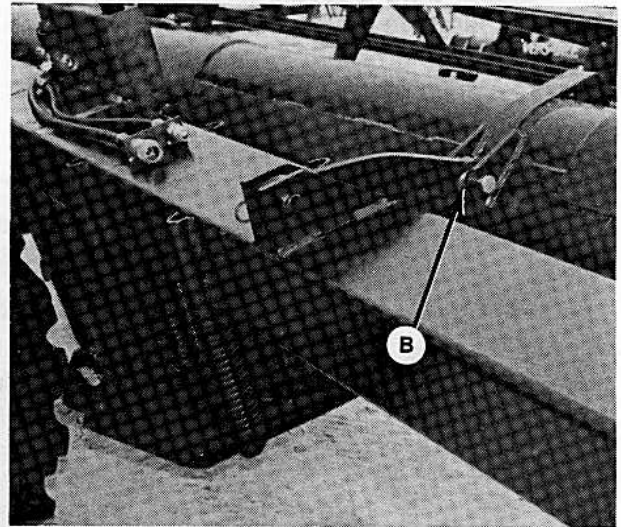

INSTALL CENTER LINK

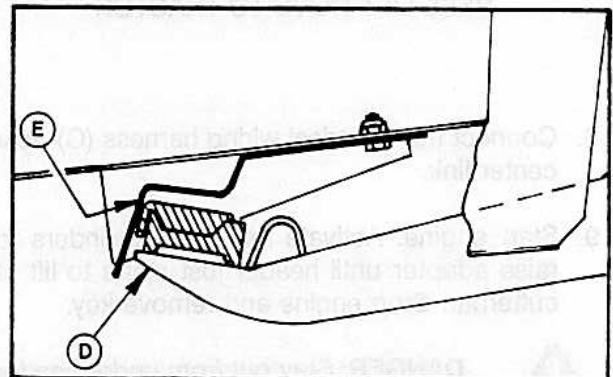

CHECK FOR PROPER ENGAGEMENT

# ATTACHING & DETACHING

## ATTACHING HEADER TO TRACTOR AND ADAPTER (continued)

6. Connect header driveline to spline shaft on adapter at (F): Pull back spring-loaded collar on driveline yoke and slide yoke onto shaft. Release collar, ensuring yoke locks in position on shaft.

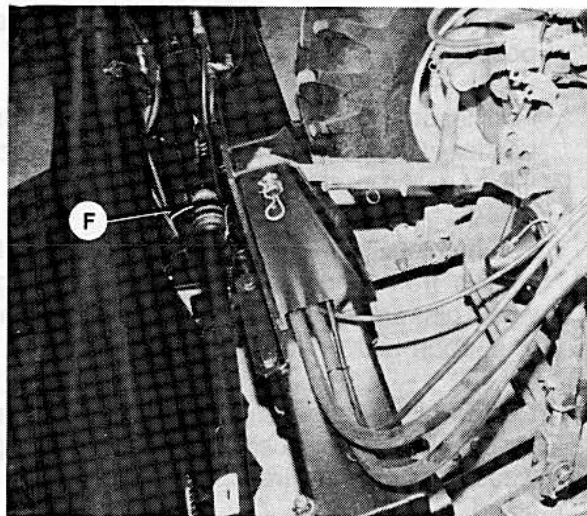

CONNECT DRIVELINE

7. Make the five hydraulic connections, matching colour coded couplers as follows:

- Four connections from header to adapter:
  - draper drive pressure (orange) (O)
  - draper drive return (blue) (B)
  - reel drive pressure (no colour code) (P)
  - reel drive return (yellow) (Y)
- One connection from header to tractor:
  - reel lift to TAN coloured EXTEND coupler (T)

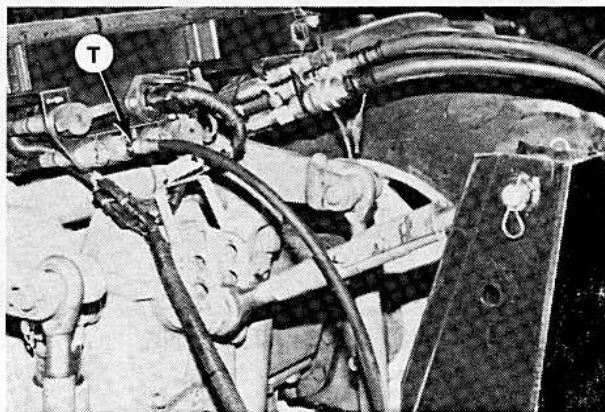

REEL LIFT HOSE TO TRACTOR

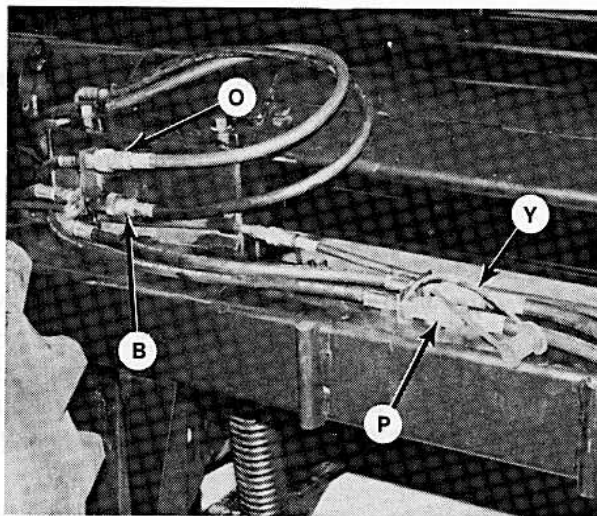

CONNECT HEADER-TO-ADAPTER HYDRAULICS

8. Connect the electrical wiring harness (G) near center link.

9. Start engine. Activate lower link cylinders to raise adapter until header just starts to lift at cutterbar. Stop engine and remove key.



**DANGER:** Stay out from under header and adapter when removing or installing pins. Three-point linkage drops at a variable rate when engine is shut off.

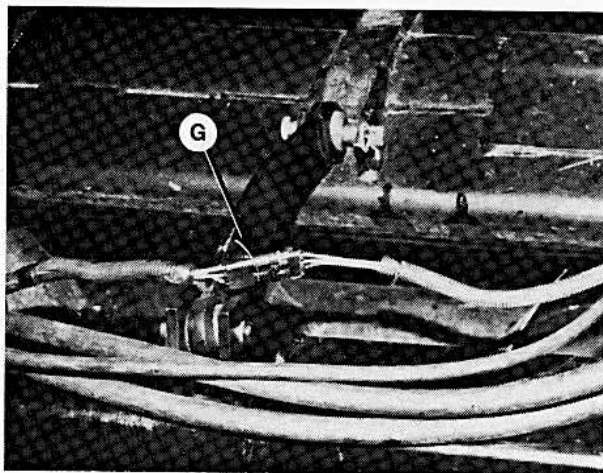

CONNECT ELECTRICAL

## ATTACHING & DETACHING

### ATTACHING HEADER TO TRACTOR AND ADAPTER (continued)

10. Remove "L" pin from float lock-out position (A) and install through header leg at (B), (engaging U-bracket in lift linkage), both sides.

**NOTE:** Rotate pin to align roll pin with key slot for removal and installation. Roll pin locks inside to secure the position.

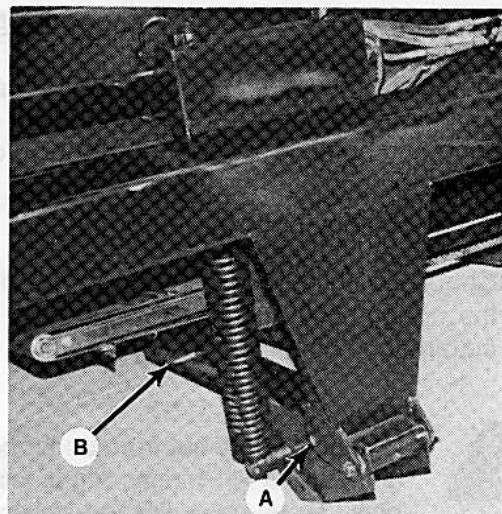

LOCK ADAPTER TO HEADER LEG

11. Start engine. Activate lower link cylinders to raise header fully. Stop engine and remove key.
12. For headers with gauge wheels, remove pins at gauge wheels and place in field position (F). (For headers with gauge wheel/transport option, gauge wheel support is not exactly as illustrated. See decal at support.)

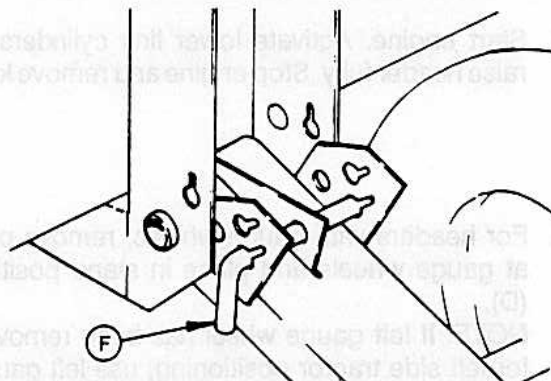

GAUGE WHEELS - FIELD POSITION

13. For headers without gauge wheels, raise header stand to storage position (G).
14. Lower header to cutting height and check that header is level end-to-end. Adjust if required. See "Header Levelling" in Operation section.
15. Lower header and adapter to ground.

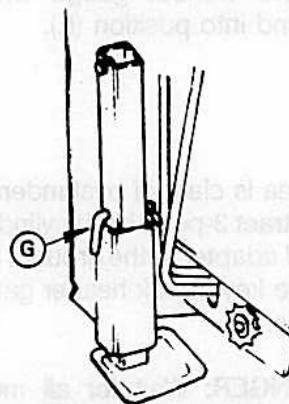

HEADER STAND - STORAGE POSITION

# ATTACHING & DETACHING

## DETACHING HEADER FROM TRACTOR AND ADAPTER

Using this procedure, adapter will remain attached to the tractor. This would be appropriate when header is to be used on a combine. Instructions for detaching both header and adapter from tractor are given on the next page.

1. Choose a level area. Lower the reel and raise the adapter until header just starts to lift at cutterbar. Stop engine and remove key.



**DANGER:** Stay out from under header and adapter when removing or installing pins. Three-point linkage drops at a variable rate when engine is shut off.

2. Remove "L" pin from header leg at (B) and install in float lock-out position (A), both sides.
3. Start engine. Activate lower link cylinders to raise header fully. Stop engine and remove key.

4. For headers with gauge wheels, remove pins at gauge wheels and place in stand position (D).

**NOTE:** If left gauge wheel has been removed for left side tractor positioning, use left gauge wheel support in "transport" position as a stand.

For headers without gauge wheels, lower header stand into position (E).

5. Be sure area is clear of bystanders, then start engine. Retract 3-point hitch cylinders to lower header and adapter to the ground. Stop engine and remove key. Block header gauge wheels, if applicable.



**DANGER:** Wait for all movement to stop. A rotating driveline can cause entanglement resulting in serious personal injury or death.

6. Disconnect header driveline from motor shaft and wire to welded lug (F) on header tube.

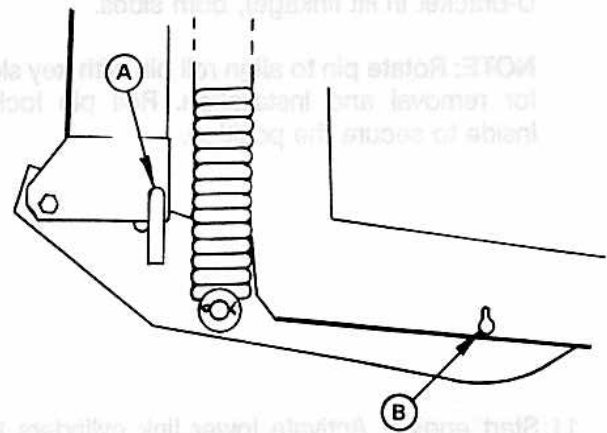

LOCK OUT HEADER FLOAT

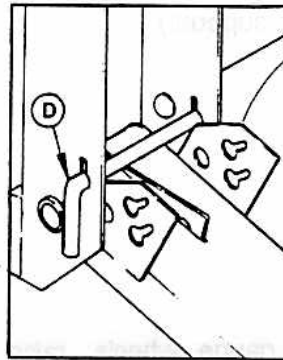

GAUGE WHEELS



HEADER STAND

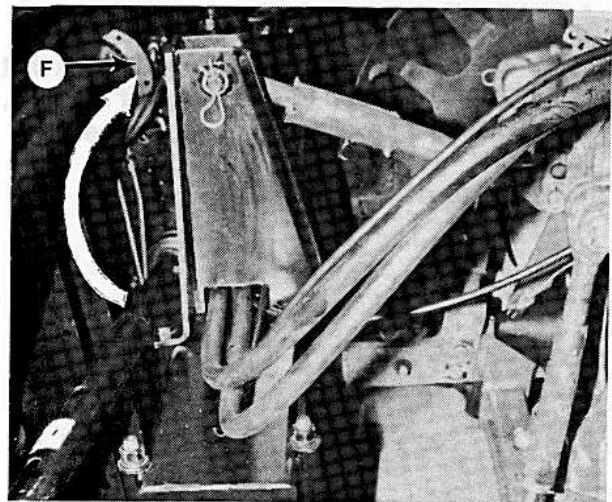

DISCONNECT AND STORE DRIVELINE



# ATTACHING & DETACHING

## DETACHING HEADER FROM TRACTOR AND ADAPTER (continued)

7. Disconnect five hydraulic lines:
  - reel drive pressure, reel return (yellow), draper drive pressure (orange) and draper return (blue) at adapter-to-header quick couplers.
  - reel lift at tan coloured EXTEND coupler on tractor.

**IMPORTANT:** Couple or cap all lines to prevent hydraulic system contamination. Be sure header stored hoses and combine stored hoses are not entangled.

8. Disconnect electrical wiring harness (G) near center link.
9. Detach center link (H) at header.
10. Slowly back away from header.

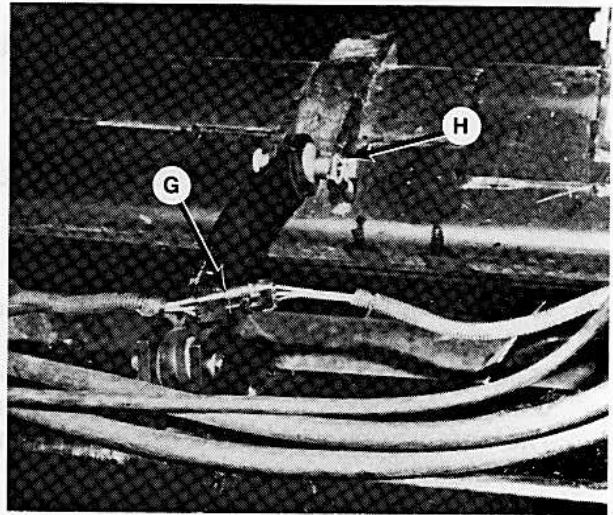

DETACH CENTER LINK & HARNESS

## DETACHING HEADER AND ADAPTER FROM TRACTOR

Using this procedure, adapter will remain attached to the header. This would be appropriate when tractor is required for other use. Instructions for detaching header only from adapter and tractor are given beginning on page 14.

1. Choose a level area. Lower the reel and lower header and adapter to the ground. Stop engine and remove key.
2. Disconnect three hydraulic lines at tractor quick couplers:
  - Two large couplers (A) at tractor left side.
  - One (reel lift) at TAN-EXTEND coupler (B).Couple or cap all lines to prevent hydraulic system contamination.
3. Detach top link (C) at adapter and place in storage support (D).
4. Manually retract latches on 3-point hitch lower links.
5. Detach electrical plug from receptacle (E). Detach header control harness plugs at (F).

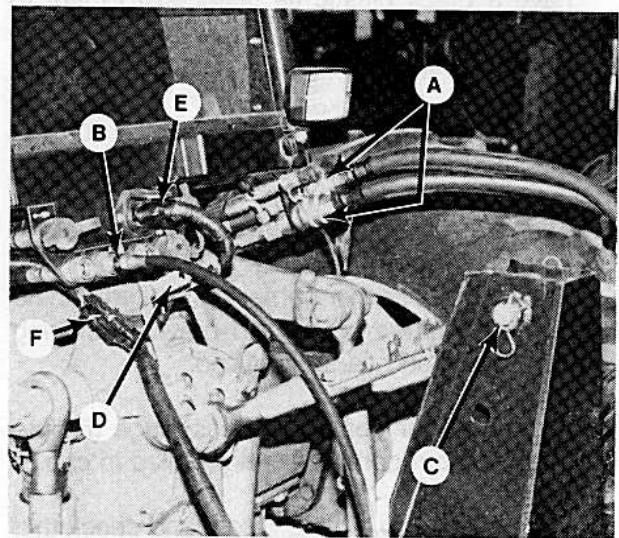

DISCONNECT HYDRAULICS, ELECTRICAL AND 3-POINT LINKS



**CAUTION:** Be sure area is clear of bystanders, then start engine. Fully retract 3-point hitch cylinders and slowly back tractor away from header.

# ATTACHING & DETACHING

## ATTACHING HEADER AND ADAPTER TO TRACTOR

1. If applicable, block both gauge wheels front and rear (B).

**NOTE:** Choose an area that is as level as possible.



**CAUTION:** Be sure area is clear of bystanders before starting engine.

2. With the 3-point hitch lower links fully lowered and the top link raised, drive tractor slowly towards the adapter until the lower link claw couplers are below the adapter lower mounts. The large claw openings make exact alignment unnecessary.
2. Raise the lower links using the hydraulic lift switch until claw couplers engage the ball bushings. An audible click will be heard as the self-locking latches engage. Stop engine and remove key.
3. Attach top link to adapter at (C).
4. Attach two 3/4 inch quick couplers (R) and (P). **IMPORTANT:** Coupler (R) comes from the tee fitting on top of the adapter, and must be attached to the RETURN coupler on the tractor. FAILURE TO PROPERLY CONNECT THIS COUPLER MAY DAMAGE SICKLE DRIVE MOTOR. These mating couplers should both have a black plastic tie fastened to them to ease identification. See "Attaching Adapter to Tractor", page 9, step 4.
5. Attach header reel lift hose coupler to TAN coloured EXTEND coupler (T) on tractor.
6. Attach 7 terminal plug from header lights wiring harness into tractor at (E). **NOTE:** Be sure that harness is routed behind top link storage support to prevent pinching harness when header is raised.
7. Attach header control harness plugs (F) into harness from control panel installed in cab.
8. Raise header to cutting height and check that header is level end-to-end. Adjust if required. See "Header Levelling" in Operation section.
9. Lower header and adapter to ground.

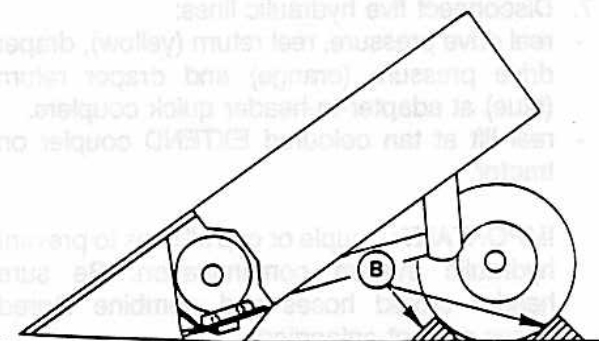

BLOCK GAUGE WHEELS

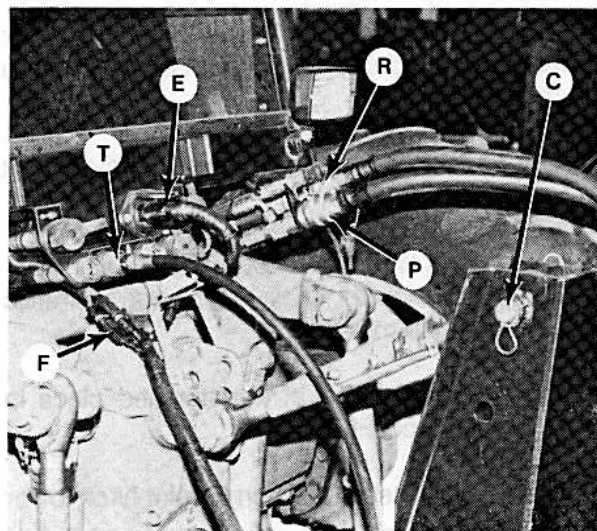

HYDRAULIC & ELECTRICAL CONNECTIONS

# OPERATION

## HEADER CONTROLS

**Header Drive** - Oil flow to hydraulic motor on adapter is controlled with "Detent" (blue) hydraulic lever on left side control panel in cab. To engage sickle, reel and draper drives, push lever away from operator until it locks in the Raise detent position. To disengage these drives, pull lever back to neutral position. Also may be controlled with the foot pedal immediately right of the left side control panel. Press the toe end of pedal to engage drives, press heel end to disengage.

**Reel Speed** - Press right side of switch (A) to increase reel speed and left side to decrease. Speed range is 10 to 60 RPM.

**Draper Speed** - Press right side of switch (B) to increase draper speed and left side to decrease. Speed range is 0 to 800 roller RPM, or 0 to 470 ft./minute (145 m/min.). A mid-range setting is suggested.

**NOTE:** If sufficient reel or draper speed cannot be achieved, a possible cause is low relief pressure. See "Hydraulics" in Maintenance/Service section.

**Deck Shift (Triple Delivery Only)** - Move switch paddle (C) to the left to shift decks to the left and reverse draper travel. Move paddle to the right to shift decks to the right and reverse draper travel. For center delivery, move paddle to center position.

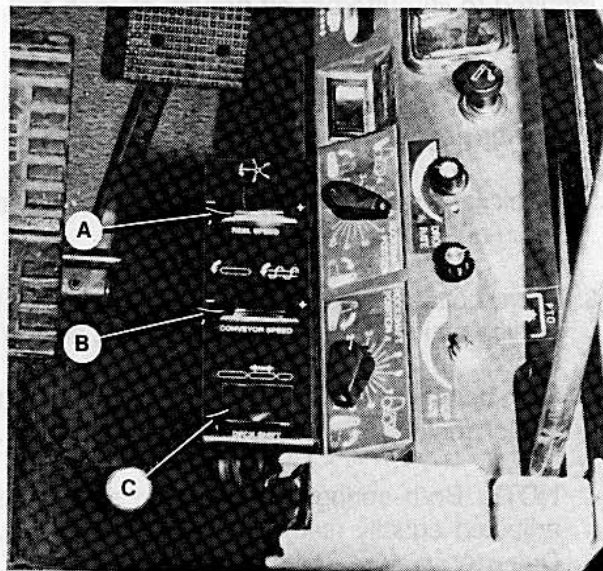

HEADER CONTROL PANEL

**Reel Height** - Controlled with "Float" (tan) hydraulic lever on left side control panel in cab. Push lever away from operator to raise reel, pull towards operator to lower. Also may be controlled with foot pedal immediately left of steering column. Press the toe end of the pedal to raise reel, press heel end to lower.

**Header/Adapter Height** - Adjusted with controls on side console to the operator's right:

**MANUAL MODE** • Set the SELECT switch for 3-point hitch operation to MANUAL mode.

- Control height with 3-point hitch switch on Forward-Neutral-Reverse lever. Press top of switch to raise and bottom to lower. Release switch when desired position is reached.

**AUTO MODE**

- Set the SELECT switch to AUTO mode.
- Set cab-end ROCKSHAFT POSITION control to desired cutting height.
- Control height with 3-point hitch switch on Forward-Neutral-Reverse lever. Press top of switch to raise header to maximum height. Press bottom of switch to lower header to pre-set cut height.

**NOTE:** See Tractor Operator's Manual for information regarding variable lowering rate.

When raising the unit, adapter will raise first, then the header. When lowering, the sequence is reversed.



**DANGER:** Stay out from under header and adapter. Three-point hitch drops at a variable rate when engine is shut off.

# OPERATION

## HEADER FLOTATION

### **IMPORTANT:**

To avoid:

- frequent breakage of sickle components
- scooping soil
- soil build-up at cutterbar in wet conditions,

set header float as light as possible without causing excessive bouncing.

Under normal conditions, adjust float spring tension so 50 to 70 lbs. force (220 to 300 N) is required to lift cutterbar off ground at each end.

To adjust header float on 9030 adapter:

1. Lower header and adapter to ground.
2. Back jam nut (A) away from spring (two at each adapter leg).
3. Turn bolts (E) clock-wise to increase float (which makes header lighter at cutting height).

Turn bolts counter-clockwise to decrease float (which makes header heavier at cutting height).

**NOTE:** Both springs on one side should be adjusted equally (same exposed bolt length). Due to weight differences side-to-side, adjustments may differ from one leg to the other.

4. Raise adapter until header just starts to lift at cutterbar and check float at both ends. Force required to lift cutterbar should be approximately the same at both ends.

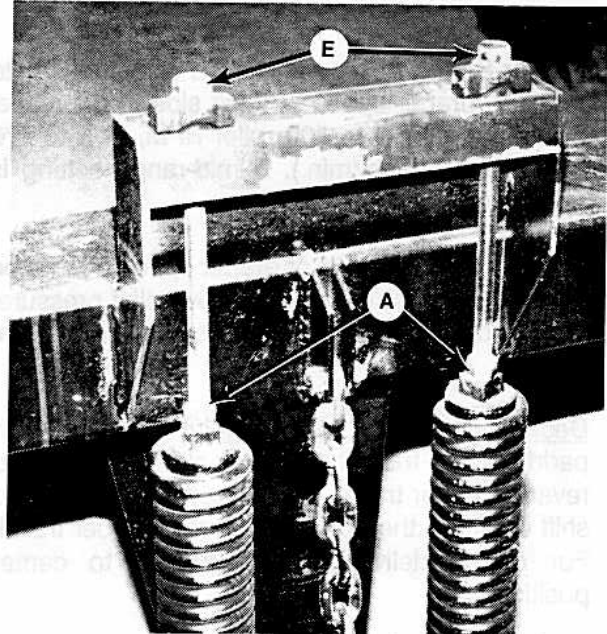

FLOAT ADJUSTMENT - 9030 ADAPTER

## HEADER LEVELLING

To adjust header end-to-end level:

1. Lower header and adapter to ground. Stop engine and remove key.
2. Adjust length of 3-point hitch top link (C) to level header. Turn the sleeve on top link to change length:

Shortening link (C) will raise the right end of the header.

Lengthening link (C) will lower the right end of the header.

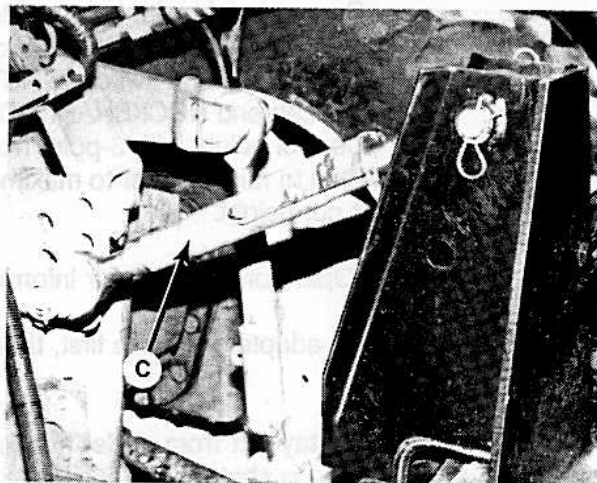

HEADER LEVELLING

# MAINTENANCE/SERVICE

## SERVICE PROCEDURES



**CAUTION:** To avoid personal injury, before servicing machine or opening drive covers:

1. Fully lower header and reel. If it is necessary to service reel in the raised position, first engage reel props.
2. Disengage header drive.
3. Stop engine and remove key.
4. Engage park brake.
5. Wait for all moving parts to stop.

Park on level surface when possible. Block wheels securely. Follow all recommendations in your Tractor Operator's Manual.

Wear close-fitting clothing and cover long hair. Never wear dangling items such as scarves or bracelets.

Wear protective shoes with slip resistant soles, a hard hat, protective glasses or goggles and heavy gloves.

Be prepared if an accident should occur. Know where the first aid kit and fire extinguisher are located and how to use them.

Keep the service area clean and dry. Wet or oily floors are slippery. Wet spots can be dangerous when working with electrical equipment. Be sure all electrical outlets and tools are properly grounded.

Use adequate light for the job at hand.

Replace all shields removed or opened for service.

Do not substitute parts, especially safety related, that may not meet strength or design requirements of the manufacturer.

Keep the machine clean. Never use gasoline, naphtha or any volatile material for cleaning purposes. These materials may be toxic and/or flammable.

## GREASING THE ADAPTER

Use an SAE Multi-Purpose High Temperature Grease with Extreme Pressure (EP) Performance and containing at least 1.5% molybdenum disulfide. Also acceptable is an SAE Multi-Purpose Lithium Base Grease.

The following greasing points are marked on the adapter by decals showing a grease gun (A) and grease interval (B) in hours of operation. Use the hour meter in the tractor cab and the "Maintenance Checklist" provided in the Header Operator's Manual to keep track of scheduled maintenance.

### Procedure:

1. Wipe grease fitting with a clean cloth before greasing to avoid injecting dirt and grit.
2. Inject grease through fitting with grease gun until grease overflows fitting.
3. Leave excess grease on fitting to keep out dirt.
4. Replace any loose or broken fittings immediately.
5. If fitting will not take grease, remove and clean thoroughly. Also clean lubricant passageway. Replace fitting if necessary.

### 50 Hours

1. Fit and Adjust (A) - two fittings

NOTE: Add this grease point to the Maintenance Checklist in the Header Operator's Manual.

# MAINTENANCE/SERVICE

## GREASING THE ADAPTER

Use an SAE Multi-Purpose High Temperature Grease with Extreme Pressure (EP) Performance and containing at least 1.5% molybdenum disulphide. Also acceptable is an SAE Multi-Purpose Lithium Base Grease.

The following greasing points are marked on the adapter by decals showing a grease gun (A), and grease interval (B) in hours of operation. Use the hour meter in the tractor cab and the "Maintenance Checklist" provided in the Header Operator's Manual to keep track of scheduled maintenance.

### Procedure:

1. Wipe grease fitting with a clean cloth before greasing, to avoid injecting dirt and grit.
2. Inject grease through fitting with grease gun until grease overflows fitting.
3. Leave excess grease on fitting to keep out dirt.
4. Replace any loose or broken fittings immediately.
5. If fitting will not take grease, remove and clean thoroughly. Also clean lubricant passageway. Replace fitting if necessary.

### 50 Hours

1. Float Arm Pivots (A) - two fittings

**NOTE:** Add this grease point to the Maintenance Checklist in the Header Operator's Manual.

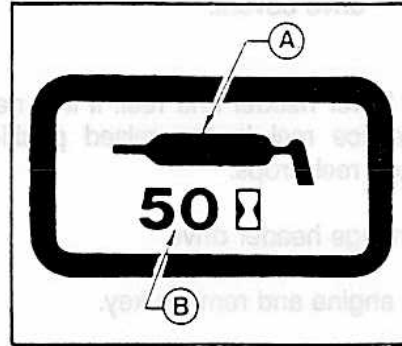

SAMPLE GREASE DECAL

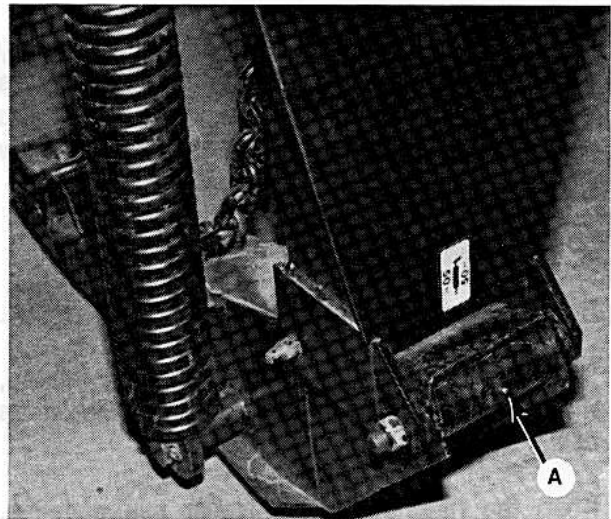

FLOAT ARM PIVOTS

# MAINTENANCE/SERVICE

## HYDRAULIC SYSTEM

**Hydraulic Hoses** - Check hydraulic hoses daily for signs of leaks.



**WARNING:** Avoid high-pressure fluids. Escaping fluid can penetrate the skin causing serious injury. Relieve pressure before disconnecting hydraulic lines. Tighten all connections before applying pressure. Keep hands and body away from pin-holes and nozzles which eject fluids under high pressure. Use a piece of cardboard or paper to search for leaks. IF ANY fluid is injected into the skin, it must be surgically removed within a few hours by a doctor familiar with this type of injury or gangrene may result.

### IMPORTANT:

- Ensure all hydraulic couplings are properly mated and fully engaged before operating header. In particular, be sure return flow from adapter is connected to tractor return coupler. Failure to connect hydraulics correctly may damage sickle drive motor. See "Attaching Adapter to Tractor", page 9, step 4.
- To avoid damage to sickle drive motor, do not exceed 16 gallons/minute flow or 3000 psi relief pressure. See Tractor Operator's Manual.
- Keep hydraulic coupler tips and connectors clean. Dust, dirt, water and foreign material are the major causes of hydraulic system damage.



AVOID HIGH-PRESSURE FLUIDS

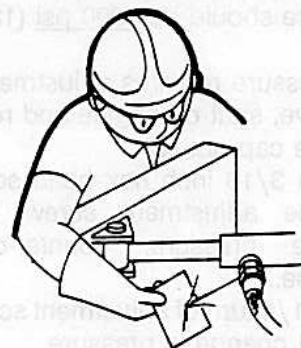

CHECK PROPERLY FOR LEAKS

### Draper Drive Flow Control Relief Pressure

A possible cause of insufficient draper speed is low relief pressure.

To check relief pressure:

1. Attach a 3000 psi (20 MPa) pressure gauge to a hose long enough to be read from operator's seat.
2. Attach this hose to draper pressure coupler (male, orange-coded) on adapter, and position the gauge near the seat.
3. Run tractor engine at operating speed.
4. Engage header drive and adjust draper speed control for normal operation.
5. Pressure should be 2000 psi (13.7 Mpa)

If relief pressure requires adjustment, disengage header drive, shut off engine and remove key:

- Remove cap nut (C).
- Turn relief screw until relief pressure is correct.
- Replace cap nut.

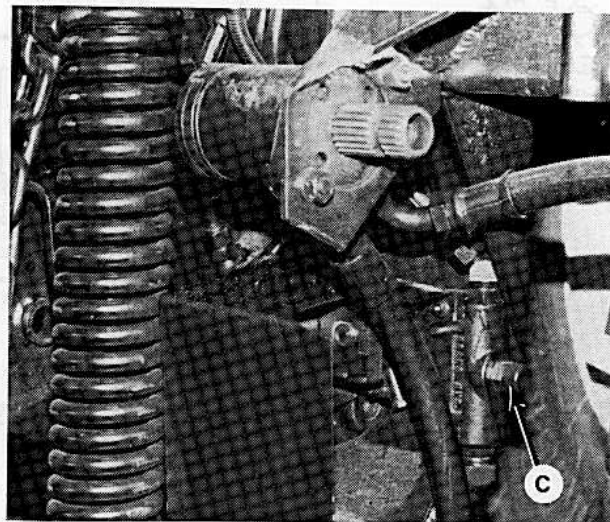

DRAPER DRIVE RELIEF ADJUSTMENT

# MAINTENANCE/SERVICE

## HYDRAULIC SYSTEM (continued)

### Reel Drive Relief Valve Pressure

Should problems be encountered with the reel drive hydraulic circuit, check relief pressure as follows:

1. Attach a 3000 psi (20 MPa) pressure gauge to a hose that is long enough to be read from the operator's seat.
2. Attach this hose to reel pressure coupler (female, no colour code) on adapter and position the gauge near the seat.
3. Run tractor engine at operating speed.
4. Engage header drive and adjust reel speed control for normal operation.
5. Pressure should be 1900 psi (13.1 MPa).

If relief pressure requires adjustment, disengage header drive, shut off engine and remove key:

- Remove cap nut (G).
- Using a 3/16 inch hex head socket wrench, turn the adjustment screw clockwise to increase pressure, counter-clockwise to decrease.

**NOTE:** 1/4 turn of adjustment screw = 150 psi (1 MPa) change in pressure.

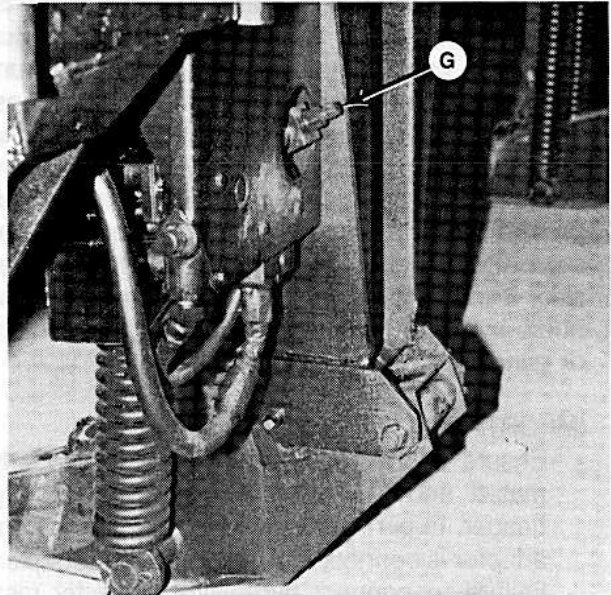

REEL DRIVE RELIEF ADJUSTMENT

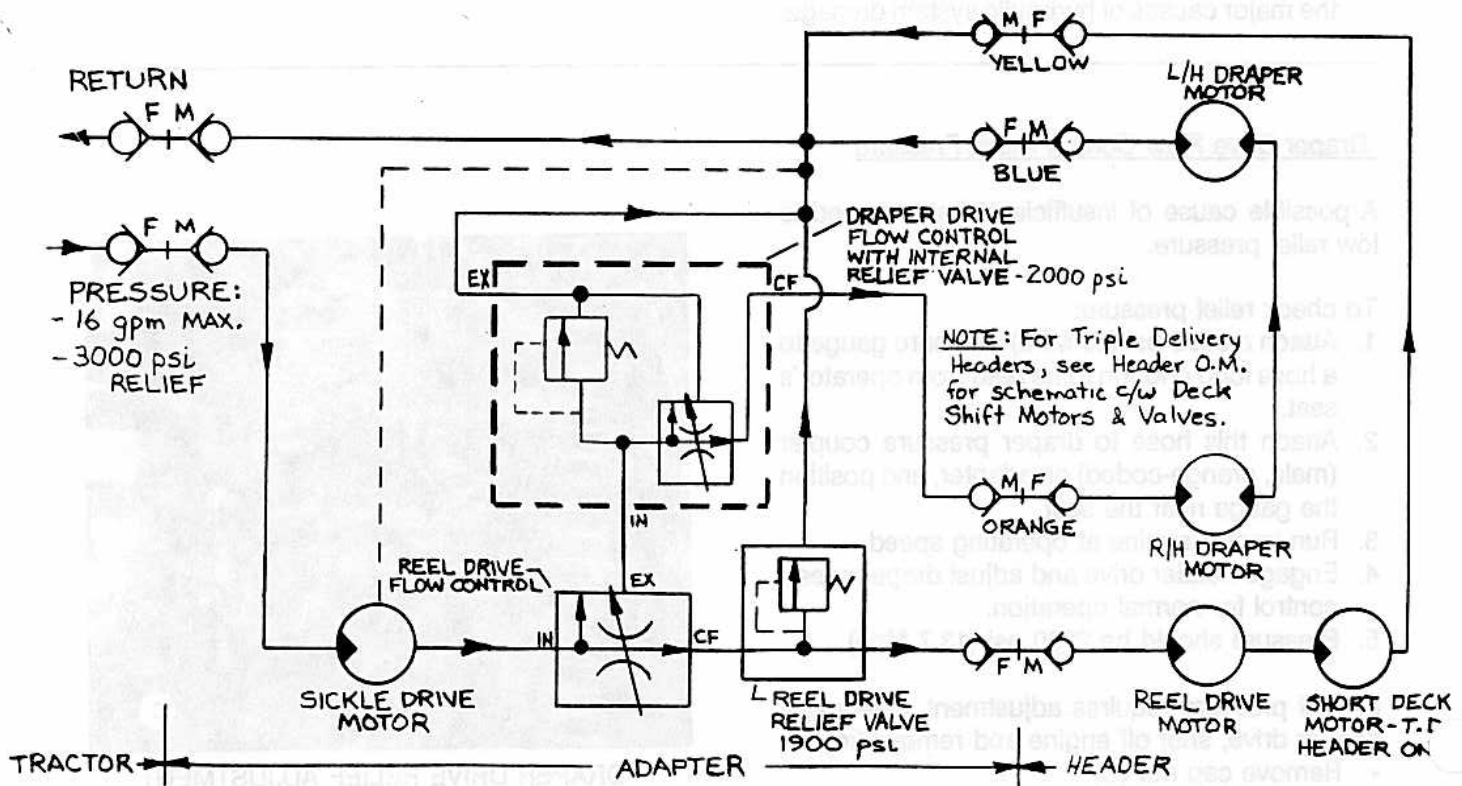

9030 ADAPTER - HYDRAULIC SCHEMATIC



# MAINTENANCE/SERVICE

## WHEEL & TIRE MAINTENANCE

For maintenance of the adapter wheel, see Header Operator's Manual for instruction on:

- Wheel Bolt Torque
- Wheel Bearing Lubrication
- Tire Safety & Care

---

## TRANSPORT

For headers with the gauge wheel/transport option.

**NOTE:** For some combinations of header size and tractor position it is necessary to remove the left gauge wheel (see page 8). Conversion to transport position is not possible unless tractor is re-positioned to allow installation of wheel.

### Converting from field position to transport:

Refer to instructions for converting from field position to transport on page 31 of your Header Operator's Manual.

Before proceeding with step 1, lower adapter to ground and lock the adapter float arm to lower leg by installing pin at (K), both sides.

### Converting from transport to field position:

Follow instructions on pages 34 and 35 of your Header Operator's Manual, then lower header and adapter to ground and remove pin from position (K) and install through header leg at (L), (engaging U-bracket in lift linkage), both sides.

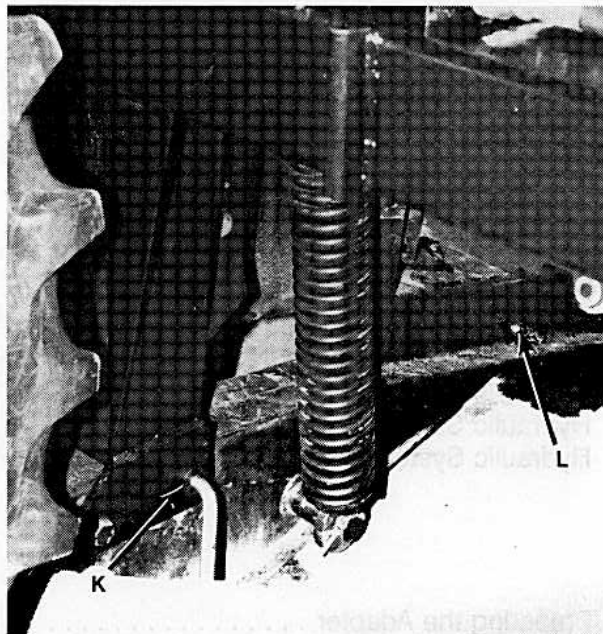

**LOCK FLOAT ARM TO LEG FOR TRANSPORT  
(HEADERS WITH TRANSPORT OPTION)**

# INDEX

| <u>A</u>                                    | PAGE |
|---|------|
| Attaching Adapter to Tractor . . . . .      | 9    |
| Attaching Header and Adapter to Tractor . . | 16   |
| Attaching Header to Tractor and Adapter . . | 11   |

| <u>D</u>   | PAGE |
|--|------|
| Deck Shift Control (T.D. Headers) . . . . .            | 17   |
| Detaching Header and Adapter<br>from Tractor . . . . . | 15   |
| Detaching Header from Tractor<br>and Adapter . . . . . | 14   |
| Draper Speed Control . . . . .                         | 17   |
| Draper Drive Flow Control<br>Relief Pressure . . . . . | 21   |

| <u>G</u>                       | PAGE |
|--------------------------------|------|
| Greasing the Adapter . . . . . | 20   |

| <u>H</u>                                | PAGE |
|---|------|
| Header/Adapter Height Control . . . . . | 17   |
| Header Drive Control . . . . .          | 17   |
| Header Flotation . . . . .              | 18   |
| Header Levelling . . . . .              | 18   |
| Hydraulic Hoses . . . . .               | 21   |
| Hydraulic Schematic . . . . .           | 22   |
| Hydraulic System Safety . . . . .       | 21   |

| <u>P</u>                        | PAGE |
|---------------------------------|------|
| Preparing the Adapter . . . . . | 7    |
| Preparing the Header . . . . .  | 10   |
| Preparing the Tractor . . . . . | 6    |

| <u>R</u>                                   | PAGE |
|--|------|
| Reel Drive Relief Valve Pressure . . . . . | 22   |
| Reel Height Control . . . . .              | 17   |
| Reel Speed Control . . . . .               | 17   |

| <u>S</u>                         | PAGE |
|----------------------------------|------|
| Safety                           |      |
| Alert Symbol . . . . .           | 4    |
| Hydraulic System . . . . .       | 21   |
| Service Procedures . . . . .     | 19   |
| Signal Words . . . . .           | 4    |
| Signs . . . . .                  | 5    |
| Serial Number Location . . . . . | 3    |
| Service Procedures . . . . .     | 19   |

| <u>T</u>            | PAGE |
|---------------------|------|
| Transport . . . . . | 23   |

| <u>W</u>                           | PAGE |
|------------------------------------|------|
| Wheel & Tire Maintenance . . . . . | 23   |



# MacDon

**Designed to Deliver!**