

PW8 Pick-Up Header SEED SAVER KIT (MD #B6429) INSTALLATION INSTRUCTIONS

The Seed Saver kit (MD #B6429) is recommended for use in lighter grain crops, for example, canola. It can be installed on a MacDon PW8 Pick-Up Header.

This document explains how to install the kit. A list of parts included in the kit is provided.

NOTE: Keep your MacDon publications up-to-date. The most current version of this instruction can be downloaded from our Dealer-only site (<https://portal.macdon.com>) (login required).

NOTE: This instruction is available in English only.

Installation Time

Installation time for this kit is approximately 20 minutes.

Conventions

The following conventions are used in this document:

- Right and left are determined from the operator's position. The front of the header is the side that faces the crop; the back of the header is the side that connects to the combine.
- Unless otherwise noted, use the standard torque values provided in the header operator's manual and technical manual.

PW8 Pick-Up Header SEED SAVER KIT (MD #B6429) INSTALLATION INSTRUCTIONS

Parts List

This kit includes the following parts:

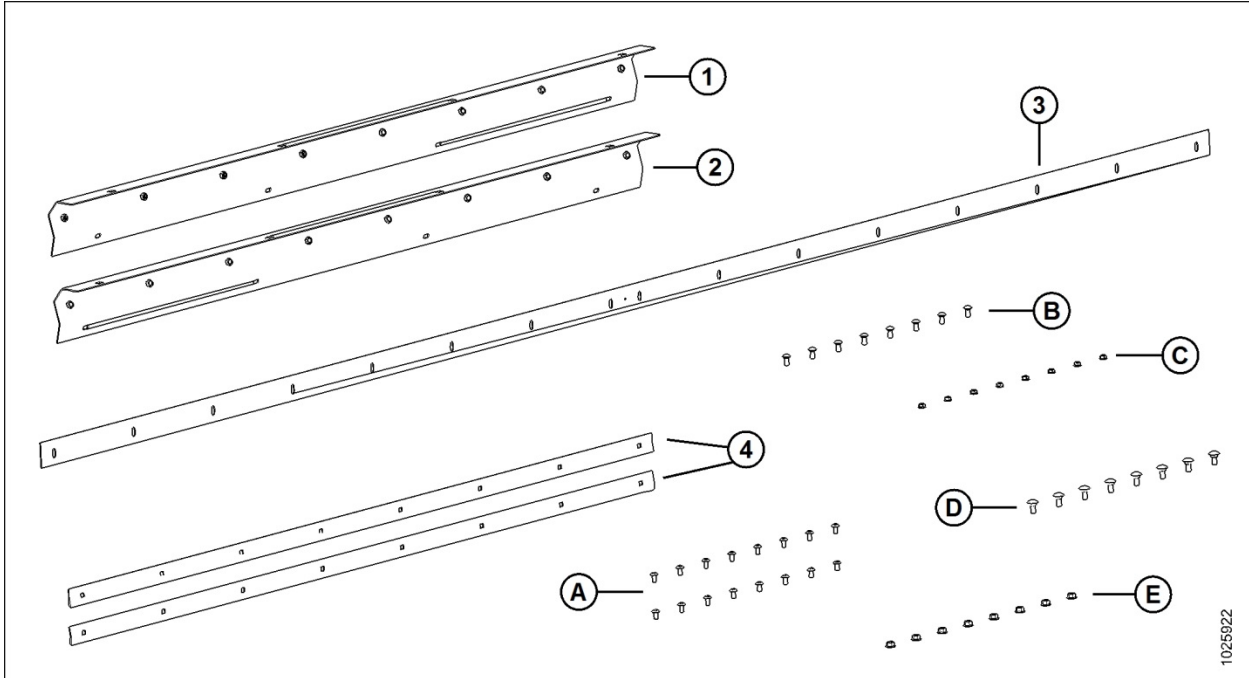

Ref	Part Number	Description	Quantity
1	302031	SUPPORT – LEFT	1
2	302032	SUPPORT – RIGHT	1
3	302023	FLAP – RUBBER	1
4	302024	SUPPORT	2
A	136395	SCREW – TORX TRUSS HD M10 X 1.5 X 20 XSPCL 8.8. A3L	16
B	136506	BOLT – RHSSN M10 X 1.5 X 25 8.8 A3L	8
C	135927	NUT – HEX SMTH FLG M10 X 1.5 8 A3L	8
D	184667	BOLT – RHSN M12 X 1.75 X 30 8.8 AA1J	8
E	148645	NUT – HEX FLG STVR LOC M12 X 1.75 10 A3L	8

PW8 Pick-Up Header SEED SAVER KIT (MD #B6429) INSTALLATION INSTRUCTIONS

Installation Instructions

To install the Seed Saver kit, follow these steps:



DANGER

To avoid bodily injury or death from unexpected start-up of machine, always stop engine and remove key before making adjustments to machine.

1. Raise the header fully, and engage the combine safety props. For instructions, refer to the combine operator's manual.
2. Stop the engine and remove the key from the ignition.
3. Locate the existing rubber flap (D) and supports (B) on the front edge of the auger pan, to the rear of the drapers.

NOTE: There are two pan seal bars (C) and two supports (B): one on the right side and one on the left. They are next to each other in the illustration, so it looks like there is only one of each.

4. Remove the eight M12 carriage bolts (A) and hex flange nuts securing rubber flap (D) and supports (B) to the pan seal bars (C), and then remove the rubber flap and supports. Discard.

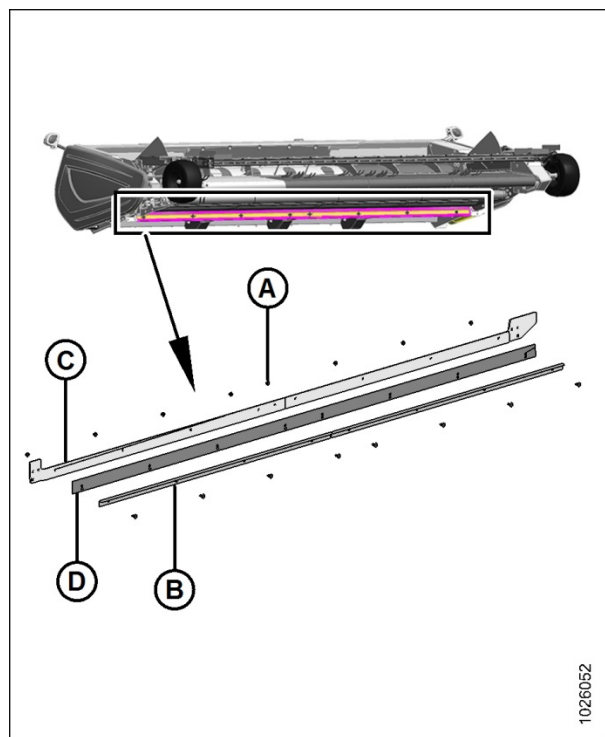

Figure 1: Pan Seal Assembly

PW8 Pick-Up Header SEED SAVER KIT (MD #B6429) INSTALLATION INSTRUCTIONS

NOTE: The draper, auger, and some other parts have been removed from the illustrations on this page for clarity.

5. Place the right support (A) (MD #302032) and left support (B) (MD #302031) along the auger pan, and secure them to the pan seal bar with eight M12 bolts (C) (MD #184667) and nuts (MD #148645).

NOTE: For a cross-section view, refer to Figure 6 on Page 5.

6. Tighten hardware.
7. Using the right and left supports as templates, drill holes through the remaining holes (D) in the supports into the auger pan for the rear carriage bolts.

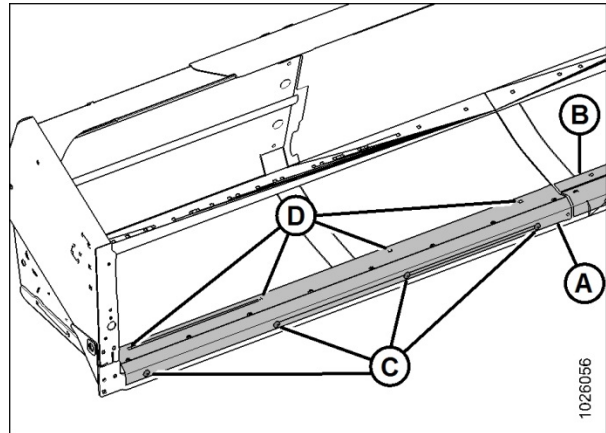

Figure 2: Installing Right Support

8. Install and tighten the rear hardware: eight M10 short-neck carriage bolts (A) (MD #136506) and eight M10 nuts (MD #135927).

NOTE: This is easier with two people: one to hold the carriage bolts in place while the other tightens the nuts on the underside of the header.

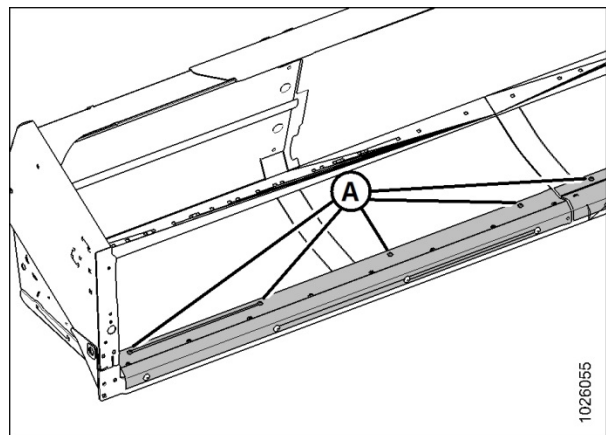

Figure 3: Installing Rear Hardware (Right Side)

9. Position rubber flap (A) (MD #302023) across right support (B) and left support (C), and then place supports (D) (MD #302024) on top.
10. Adjust rubber flap (A) so that it extends 20 mm (13/16 in.) in front of supports (D).

Refer to Figure 5 on Page 5.

11. Secure in place with 16 M10 Torx® truss screws (E) (MD #136395). Tighten until supports (D) start to bend. Do **NOT** overtighten.

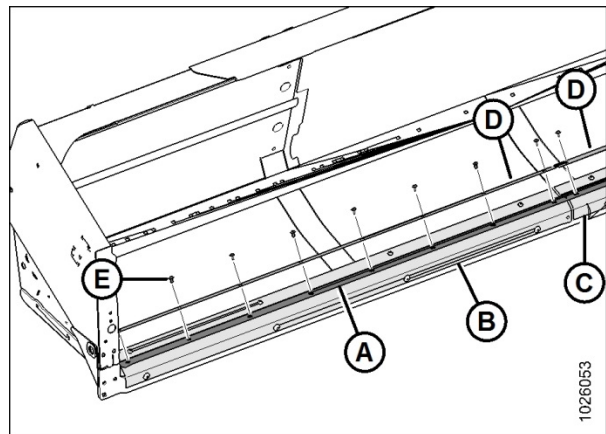

Figure 4: Installing Rubber Flap and Supports (Right Side)

PW8 Pick-Up Header SEED SAVER KIT (MD #B6429) INSTALLATION INSTRUCTIONS

- A – 20 mm (13/16 in.)
- B – Right support (MD #302032)
- C – Rubber flap (MD #302023)
- D – Support (MD #302024)
- E – Torx® truss screw (MD #136395)

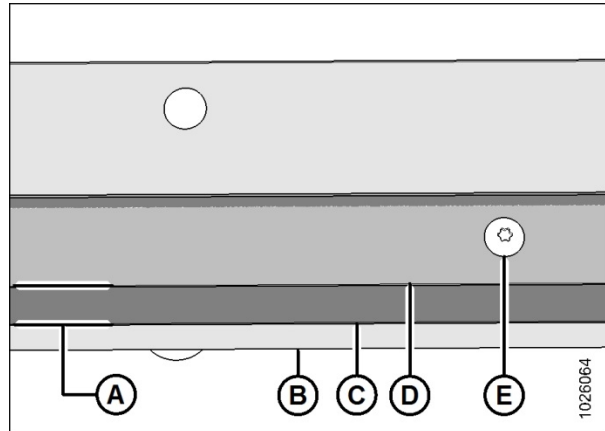

Figure 5: Rubber Flap Positioned Correctly

- A – Pan seal bar
- B – M12 bolt (MD #184667)
- C – M12 nut (MD #148645)
- D – Left support (MD #302031)
- E – Rubber flap (MD #302023)
- F – Support (MD #302024)
- G – Torx® truss screw (MD #136395)
- H – M10 short-neck carriage bolt (MD #136506)
- J – M10 nut (MD #135927)

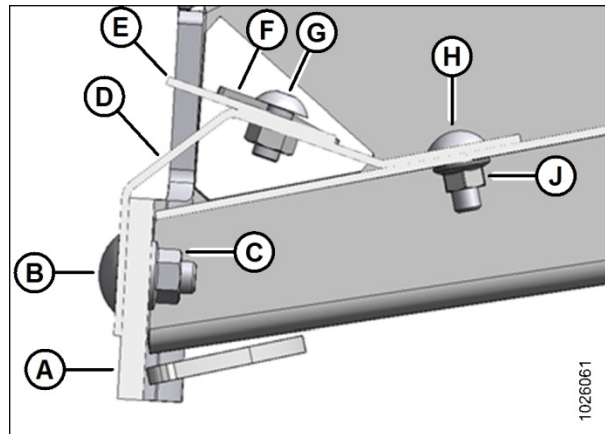

Figure 6: Cross-Section View of the Seed Saver Kit Installed